

# Techniques for Mixing and Scaling in Mechanically Agitated Vessels

A Major Qualifying Project Submitted to the Faculty of  
Department of Chemical Engineering  
Worcester Polytechnic Institute  
In partial fulfillment of the requirements for the  
Degree in Bachelor of Science  
In  
Chemical Engineering  
By:

---

Sean Deans

---

Martin Fitzgerald

Date: 4/26/17

Sponsoring Organization:

Sunovion

Project Advisors:

---

Professor William Clark, Advisor

---

Professor Stephen Kmiotek, Advisor

This report represents work of WPI undergraduate students submitted to the faculty as evidence of a degree requirement. WPI routinely publishes these reports on its web site without editorial or peer review. For more information about the projects program at WPI, see <http://www.wpi.edu/Academics/Projects>.

## Acknowledgements

We would like to thank our advisors, Professor William Clark and Professor Stephen Kmiotek, for their guidance throughout the duration of our project. In addition, we would like to thank Sunovion Pharmaceuticals for sponsoring our project, particularly through our contact with Robert Prytko and Haito Zhang.

## Abstract

The purpose of this project was to investigate the use of thermocouples to measure the mixing of thermally differentiated streams of water (TDWS) for the purpose of determining mixing time and locating mixing regions within Sunovion Pharmaceuticals Inc.'s Büchi CR-60 reactor vessel. To do so, the team utilized two empirical methods, decolorization with a phenolphthalein-indicated acid-base mixture, and positive colorization with methylene blue dye. Decolorization allowed the team to locate slow mixing zones for the purpose of determining appropriate probe placement to implement TDWS. Positive colorization, due to its need for a relatively small addition phase, allowed the team to confirm mixing times through modeling the reactor vessel with DynoChem software. With the results of the two empirical methods, the team experimented with the use of TDWS, paying particular attention to careful probe placement and the necessary ratios between bulk phase and addition phase. Owing to a broad range of possible operational conditions for Sunovion's reactor, the team presented its findings with an emphasis on the parameters which most dramatically affect the tested empirical methods in order that Sunovion can test with a method or combination of methods which will most closely resemble their desired real world application.

# Table of Contents

Acknowledgements.....	2
Abstract.....	3
Table of Figures.....	6
Introduction.....	7
Goals.....	7
Background.....	9
First-order effects.....	9
Mixing Dynamics – Macro, Micro, Meso.....	10
Mixing regions.....	12
DynoChem.....	13
Methods for measuring mixing time.....	14
Colorimetry.....	14
Electrical resistance tomography.....	15
Planar laser-induced fluorescence.....	16
Thermography.....	16
Conductometry and pH.....	17
Scaling Up Reactors.....	18
The CR-60 Reactor Vessel.....	19
Methodology.....	21
Phenolphthalein.....	21
Methylene Blue.....	22
Thermocouple.....	24
Scaling Up with Dynochem.....	26
Experimental Set-Up.....	28
250 mL Reactor.....	28
500mL Reactor.....	28
3L Reactor.....	29
Decolorization Set-Up: 250 mL Scale.....	29
Decolorization Set-Up: 500 mL Scale.....	30
Decolorization Set-Up: 3L Scale.....	31

Thermocouple Set-Up: 500mL Scale.....	32
Thermocouple Set-Up: 3L Scale.....	33
Results.....	34
Methylene Blue: 250mL Scale.....	34
Methylene Blue: 500mL Scale.....	35
Methylene Blue: 3L Scale.....	36
Thermocouple: 500mL Scale.....	36
Thermocouple: 3L Scale.....	37
Phenolphthalein: 250mL Scale.....	38
Phenolphthalein: 500mL Scale.....	39
CR60 Scale Up Results.....	40
Thermocouple Placement on The CR60.....	41
Discussion / Analysis.....	42
General patterns.....	42
Addition time.....	43
Location of addition.....	43
Size of bulk phase relative to the mixing phase.....	44
Liquid density, relative liquid densities.....	45
Decolorization.....	45
Methylene Blue Dye.....	48
TDWS.....	49
Dynochem.....	51
Operational Conditions.....	52
Particle Tracing.....	53
Recap, Including Weaknesses in Assessment.....	55
Recommendations.....	56
Appendices.....	59
Appendix A: Overhead Schematics of Experimental Setups.....	59
Appendix B: Thermocouple Experimental Results.....	60
Appendix C :Dr.Zhang’s Sodium Thiosulfate Decolorization Method.....	66
Appendix D: Schematic of the Impeller in the CR-60 Reactor.....	68

## Table of Figures

Figure 1 Schematic of an Electrical Resistance Tomography experimental setup .....	16
Figure 2 Experimental Setup of a Thermography Imager .....	17
Figure 3 Schematics for the Buchi CR Series Reactors .....	20
Figure 4 Dimensions for the Buchi CR Series Reactors .....	20
Figure 5 Screenshot of Dynochem Input Screen in "Liquid-Liquid-DBS.xls" .....	27
Figure 6 Screenshot of Dynochem Results Screen in "Liquid-Liquid-DBS.xls" .....	27
Figure 7 The experimental setup for the 250mL decolorization experiment .....	30
Figure 8: 500mL decolorization experimental setup .....	31
Figure 9 The experimental setup for the 3L decolorization experiment .....	32
Figure 10 The Experimental Setup of the 500mL Thermocouple experiments .....	33
Figure 11 The experimental setup for the 3L thermocouple experiment .....	34
Figure 12:Schematic of CR60 with Thermcouple Placement Indicated .....	41
Table 1 The results for the 250mL Methylene Blue experiments .....	35
Table 2 The results for the 500mL Methylene Blue experiments .....	35
Table 3 The results for the 3L Methylene Blue experiments .....	36
Table 4 The trial records for the 500mL thermocouple experiments .....	37
Table 5 The results for the 500mL thermocouple experiments .....	37
Table 6 The trial records for the 3L thermocouple experiments .....	38
Table 7 The results for the 3L thermocouple experiments .....	38
Table 8 The results for the 250mL phenolphthalein experiments .....	39
Table 9 The results of the 500mL phenolphthalein experiment .....	39
Table 10 The Collection of Results for the CR60 Scale Up .....	40
Appendix A.1 Overhead schematic of The Thermocouple experimental setup .....	59
Appendix A.2 Overhead schematic of the Decolorization experimental setup .....	59
Appendix B.1 Thermocouple Data for Trial 1 on 500mL .....	60
Appendix B.2 Thermocouple Data for Trial 2 on 500mL .....	60
Appendix B.3 Thermocouple Data for Trial 3 on 500mL .....	61
Appendix B.4 Thermocouple Data for Trial 4 on 500mL .....	61
Appendix B.5 Thermocouple Data for Trial 5 on 500mL .....	62
Appendix B.6 Thermocouple Data for Trial 6 on 500mL .....	62
Appendix B.7 Thermocouple Data for Trial 1 on 3L.....	63
Appendix B.8 Thermocouple Data for Trial 2 on 3L.....	63
Appendix B.9 Thermocouple Data for Trial 3 on 3L.....	64
Appendix B.10 Thermocouple Data for Trial 4 on 3L.....	64
Appendix B.11 Thermocouple Data for Trial 5 on 3L.....	65

# Introduction

Bulk blending is among chemical engineering's most common unit operations. As such, researchers have devoted serious effort towards understanding the dynamics of this type of mixing. Sunovion Pharmaceuticals, Inc., has requested that we review the available literature and perform experiments for the purpose of creating a method which can easily predict or measure mixing time in Sunovion's Buchi CR-60 reactor vessel. In particular, Sunovion was concerned with the potential measurement of thermally differentiated streams of water via thermocouples to deduce mixing time in the CR-60 vessel.

We completed this work between January and April of 2017 in fulfillment of Worcester Polytechnic Institute's requirements for the Major Qualifying Project.

## Goals

The purpose of this project was to determine a method to predict or measure the blending time in a Buchi CR-60 reactor vessel, with particular emphasis placed on evaluating methods utilizing thermally differentiated streams of water (this method hereafter referred to as TDWS [thermally differentiated water streams]). In order to do so, the team had to investigate similar methods of measuring mixing time and compare their strengths and weaknesses to determine an effective way to implement Sunovion's desired thermocouple method. To this end, the team developed three smaller subgoals to guide our work.

*1) To research and evaluate methods which indicate mixing subzones within the larger bulk liquid phase.*

One of the noticeable benefits to TDWS is both its low implementation cost and its low operational cost. However, its low implementation cost is contingent on being able to implement TDWS

with a limited number of strategically-placed thermocouples. To do so, the operator must know which regions within the reactor will, when measured, produce a reading which best indicates the current extent of mixing within the reactor (i.e., must be among the slowest regions to mix). Then, when these regions stabilize, the operator can infer that the other regions within the vessel have likewise stabilized, and so on.

On the other hand, if the operator does not know where to place their thermocouples so as to take only the most meaningful readings, then the operator will need to use a large number of thermocouples distributed evenly around the mixing vessel. This would be the only way for the operator to ensure they had accurately measured mixing in the vessel, taking into account slow mixing zones as well as quick mixing zones. This, however, results in a high implementation cost and may potentially cause needless complication.

As such, the team held it as a goal to develop methods to determine which zones were slowest to mix in order that Sunovion could strategically place thermocouples in an implementation of TDWS in their CR-60 reactor.

*2) To research and evaluate methods which validate the identification of mixing subzones.*

The team understands that Sunovion may want to mix in the CR-60 under a variety of operating conditions. Due to the proprietary nature of Sunovion's operations, the team has not focused on a specified "normal operating condition" but has sought a method that can work across a variety of situations. As above, a successful implementation of TDWS is dependent on the placement of thermocouples within the vessel. However, how can one be sure that the thermocouples are placed correctly? Such certainty is essential to TDWS and, as such, the team took it as a goal to develop a series of recommendations to determine with more certainty that a certain thermocouple placement is appropriate.



3) *To extrapolate results to the CR-60 from smaller mixing vessels.*

While Sunovion was concerned with mixing in their CR-60 reactor, it was desirable to be able to perform experiments on a smaller scale and extrapolate the results to the CR-60 reactor. By performing experiments on a small scale, Sunovion can both save costs in the instance of expensive reagent, as well free the CR-60 for its use in industrial application. Additionally, scaling up experiments from a small-scale will allow Sunovion to apply the results of this report to a different reactor in the future, as opposed to studying only the CR-60. In other words, in scaling up, one gains predictive capabilities over mixing dynamics in a given vessel.

## Background

### First-order effects

Mixing is a complicated unit process. To describe it involves careful study of fluid mechanics and mass transport. Many of the principles which underlie mixing are unknown or, are at least difficult to express mathematically in a useful way. Previous studies<sup>1</sup> have modeled mixing with systems of empirical equations deriving from carefully controlled experiments off of a wide range of variables, though often with firm constraints on control variables. In other words, predicting mixing is a difficult

---

<sup>1</sup> For an overview of many different models, see Patwardhan and Joshi, "Relation between Flow Pattern and Blending in Stirred Tanks" (1999)

task and, even when one makes a prediction, it is difficult to tell under what circumstances that prediction is useful. However, while there are a plethora of operational parameters with tangible effects on mixing, not all parameters have effects of the same magnitude. Certain variables will produce a dramatically more noticeable change when adjusted than others. Thus, in order to produce recommendations in a more timely, and easier to implement, fashion, the team performed a literature review to isolate first-order effects. In this way, our method to measure mixing time in the CR-60 vessel relied on the measurement of fewer variables, and thus will be easier for Sunovion to implement. There exists a large body of literature concerning which parameters constitute first-order effects. The team found the following to be most critical.

Note that the parameters listed below are most often considered first-order effects in the calculation of mixing time. While mixing time is not a complete picture of the mixing dynamics of a certain vessel, it is nonetheless a useful illustration of, all other things being similar, a parameter's overall effect on the system.

- The ratio of impeller diameter to tank diameter (Fasano et. al. 1994)
- Liquid height in tank (Fasano et. al. 1994)
- Viscosity of liquid phases (Al Qaessi 2007)
- Power number, effective power input [including rpm, torque] (Al Qaessi 2007)
- Impeller clearance (Nere et. al. 2003)
- Baffling (Nere et. al. 2003)
- Mixing regime [turbulence, laminarity, etc.] (Cooke 2005)

## Mixing Dynamics – Macro, Micro, Meso

Within the broader scope of mixing there are several different actions of mixing which are worth considering. Generally speaking, one can conceive of mixing on the orders, in decreasing scale, of macromixing, mesomixing, and micromixing. Macromixing refers to the bulk motion of fluid in a vessel due to agitation. Mesomixing, the next smallest, refers to turbulent agitation, particularly as it relates to

the inlet flow of a stream into the vessel. Finally, micromixing describes mixing on the molecular scale between localized regions in the bulk phase of the vessel. For example, micromixing includes molecular diffusion and heat conduction.

Bulk motion disperses small fluid particles within the bulk phase. However, bulk motion cannot actually change the composition of individual infinitesimal particles within the vessel. Instead, macromixing merely rearranges the infinitesimal particles so as to remove them from homogenized macro-level zones. Mory, in *Fluid Mechanics for Chemical Engineering*, summarizes the phenomenon:

“The mixing of a product into a fluid flow results from two mechanisms: stirring, which regards to the advection of fluid particles, and molecular diffusion, which is characterized by [molecular diffusion] ... Molecular diffusion is the only mechanism that can achieve the mixing by modifying the concentration of constituents inside fluid particles ... Stirring moves elementary cells relative to one another, without being able to modify their size.” (Mory chap 10.3-10.4)

In other words, while to an observer the bulk equilibrium seems to take place by a simple general “dispersion”, there are in reality two very different mechanisms at play<sup>2</sup>. One can then imagine that in different systems either macro- or micromixing phenomena could dominate. In the case of an extremely fast reaction, micromixing effects may exceed the effects of macromixing. Conversely, for dilute, nonreactive systems, an operator would likely care more about macromixing.

---

<sup>2</sup> This account neglects mesomixing, but not necessarily at the cost of accuracy. Mesomixing is a more specialized concern and its phenomena do not change the core of the macro/micro mixing relationship.

For a non-reactive mixture of physically similar constituents, the differences between micro- and macromixing are more difficult to spot, especially when the bulk phase has homogenized. However, even in the case of even distribution of constituents on the macro scale, there can still exist heterogeneous zone on the micro scale. For instance, in a mixture of immiscible liquids, one can reasonably expect to find small zones of vastly different composition between fluid particle to fluid particle, even if the overall distribution of liquids is even across the entire vessel.

For the purpose of the team's investigation, both macro- and micromixing phenomena featured key roles in understanding and implementing TDWS. The purpose of TDWS is to allow Sunovion to measure overall macromixing time in the CR-60 reactor. However, in order to do so, the team must place probes in appropriate locations which are indicative of the progress of the overall macromixing. While the end goal of probe placement is determination of macromixing progress, placement itself requires knowledge of micromixing dynamics in the vessel. Where the team wished to place probes at the slowest mixing zones, the team had to be able to measure micromixing effects such that these zones became apparent.

## Mixing regions

Where one of the team's primary objectives is to determine the appropriate placement of thermocouple, the team performed a literature review concerning the ability to predict mixing regions within a vessel from principle. The team desired a method to predict where slow mixing zones were located by calculations based on factors such as the first-order effects listed above. The team found two general approaches: to either use general heuristics or to use computational fluid dynamics.

Patwardhan et al. note that computational fluid dynamics approaches constitute the most complete and reasonable approach to modeling the internal mixing regions within a reactor (Patwardhan

et al.). Programs such as COMSOL Multiphysics have utilities which enable the visualization of poor mixing zones and calculation of mixing time. While mixing is not completely explainable through computational fluid dynamics alone, computational fluid dynamics software such as COMSOL Multiphysics are capable of providing a greater understanding of the mixing regions when compared to visualization techniques alone. With Sunovion advising against the use of COMSOL Multiphysics and similar software, the team aimed to use general heuristics in order to predict mixing time, mixing regions, and general scale up of reactors.

## DynoChem

DynoChem is a software tool created by Scale-up Systems. It is an excel-based program which allows the use of many published utilities in order to model complicated engineering processes. These utilities include liquid-liquid mixing, solid-liquid mixing, gas-liquid mixing, plug flow reactor kinetics, CSTR modeling, and so forth. The team took advantage of a liquid-liquid mixing utility which could predict both the mixing time in a reactor vessel as well as give insight into the performance of a scaled-up vessel. Mixing time correlations in the program were defined as follows<sup>3</sup>:

Turbulent regime

$$\theta = C_1 * s^{-\frac{1}{3}} * \left(\frac{T}{D}\right)^{\frac{1}{3}} * T^{\frac{2}{3}}$$

Transitional regime:

---

<sup>3</sup> Information taken from DynoChem's "liquid-liquid\_DB.xls" utility

$$\theta = C_2 * s^{-\frac{2}{3}} * \frac{\mu}{\rho_L} * \left(\frac{T}{D}\right)^{\frac{2}{3}} * T^{-\frac{2}{3}}$$

Where

$\theta$  = mixing time (s)

$C_1$  = constant =  $5.4 / (V / (T^2 * H))^{1/3}$

$C_2$  = constant =  $38025 / (V / (T^2 * H))^{2/3}$

$s$  = power per unit volume input (kW / m<sup>3</sup>)

$T$  = tank diameter (m)

$D$  = impeller diameter (m)

$\mu$  = liquid viscosity (Pa \* s)

$\rho$  = liquid density

$V$  = liquid volume (m<sup>3</sup>)

$H$  = liquid level (m)

## Methods for measuring mixing time

Ascanio identifies five common experimental techniques for measuring mixing time in stirred vessels: colorimetry, electrical resistance tomography, planar laser-induced fluorescence, thermography, and conductometry and pH (Ascanio 2013). What follows is a brief overview of the five methods, including those used in the team's experimentation. The team was particularly concerned with ways to measure bulk mixing times, which Ascanio defines as "the time required to get all points in the vessel uniformly distributed" (Ascanio 2013), as a function of localized measurements within the vessel.

### Colorimetry

Colorimetry is the most common technique for measuring mixing times in a vessel (Ascanio 2013). Colorimetry follows one of two approaches: either positive colorization or decolorization. For positive colorization colorimetry, an operator will add dye into a mixing vessel and follow the path of it

as it is dispersed. When the bulk phase reaches a homogenous color, the operator can determine that the vessel has become fully-mixed and use this information to determine mixing time.

In the instance of decolorization, the process happens in reverse. The bulk phase of the reactor begins at a certain color and a decolorizing agent is added. Again, once the mixture reaches a homogenous color, the mixture can be identified as well-mixed. Decolorization is particularly useful to identify stagnation zones as the final zones to decolorize are clearly visible to an operator.

Cooke (2005), however, notes that decolorization is sensitive to the accuracy of stoichiometric ratios. In the event that the ratios are not exact, measured mixing time will vary according to the degree of inaccuracy.

### Electrical resistance tomography

Dickin and Wang (1996) describe how electrical resistance tomography can give insight in many aqueous processes, including miscible liquid-liquid mixing. In such an application, an operator fits a vessel with several planes of precisely-placed electrodes which are in constant contact with the electrolyte-laden process solution. A current source applies electrical current to the mixture, which is read by the sensory array. The data from the array is reconstructed digitally using algorithms which parse impedance readings into a model of the mixing dynamics of the vessel. Dickin and Wang (1996) give an example of this setup which is reproduced below as Figure 1.

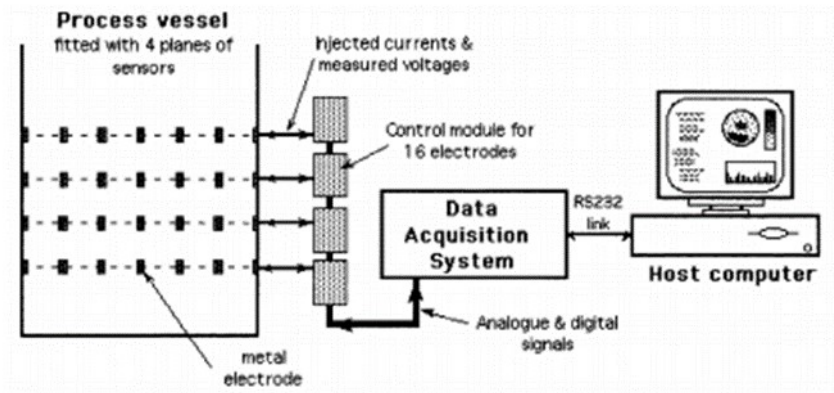

Figure 1 Schematic of an Electrical Resistance Tomography experimental setup

### Planar laser-induced fluorescence

This approach is a non-intrusive technique which consists of a light source, a narrow-band camera, and a dye which re-emits light when excited by the laser (Ascanio 2013). In a word, this technique records dye concentration at various regions in the vessel by using a specially filtered camera which can deduce the concentration via measuring light emitted.

### Thermography

Thermography an imaging technique which takes advantage of the material properties of liquid crystal (Ascanio 2013). Lee and Yianneskis (1997) describe the use of liquid crystal thermography for the purpose of measuring mixing characteristics in stirred vessels. This technique works by exploiting the color-changing effects of thermographic liquid crystals. An operator suspends liquid crystals in the vessel and uses a digital image processing system to create a composite image of the coloration across the vessel. This color image, indicative of temperature, indicates the extent of mixing of thermally differentiated flows. Lee and Yianneskis (1997) include an example of an experimental setup for liquid crystal thermography, reproduced below as Figure 2.



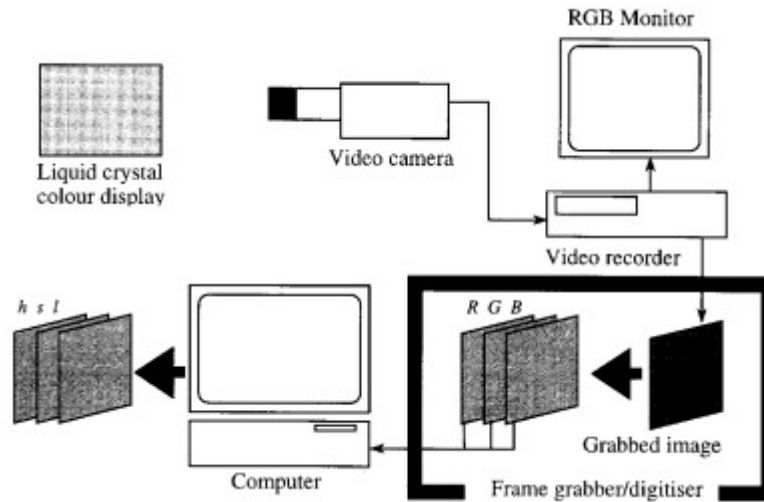

Figure 2 Experimental Setup of a Thermography Imager

## Conductometry and pH

Conductometry, of which TDWS is an approximate subset, is an intrusive method involving the placement of probes into the mixing vessel. In the case of Conductometry, an operator will place conductivity probes into a vessel at slow mixing zone and establish a baseline reading of conductivity. Then, an operator will mix in a salt solution and measure the change in conductivity, seeking when the conductivity probes provide a constant reading. (Cooke 2005) cites his and Khang and Levenspiel (1976)'s criteria for efficacious conductometry implementations:

- The measuring volume is small and known.
- The probes have a very fast response time.
- The response of the probes is linear over a wide range of liquid conductivities
- The conductivity probes are stable over long time intervals.
- The probes give a continuous time history of the concentration fluctuations at the sample points. These concentration-time histories can readily be analysed to obtain mixing times for a specific degree of mixing.

TDWS works according to a similar principle, except in that it exchanges conductivity meters for thermocouples and uses thermally differentiated streams instead of conductive materials. In principle, however, the mechanism is similar. An operator will place probes appropriately and measure temperature transients from the addition time to equilibrium. pH, too, works in much the same way.

## Scaling Up Reactors

There are several methods for scale-up of a reactor. Three methods more prominently and were requested by advisors and Sunovion to be studied. Each method stands on it's how and has strengths and weaknesses depending on the available resources. With the constants that are held in the reactor, each form of scale up using the above equation relates to a factor in power per unit volume being altered.

The first method examinable is to maintain a constant power per unit mass throughout the reactors. This methods uses the following correlations:

$$P = P_0 * \rho_L * N^3 * D^5$$

With the additional variables defined as:

P = Power input (w)

P<sub>0</sub> = Power number [dependent on impeller type] (unitless)

N = Impeller speed (s<sup>-1</sup>)

This equation is valid under the assumption that the reactor is not undergoing any vortexing at the surface of the water, which is avoided by the addition of baffles.

With this equation, the power needed is solved from the variation of the impeller speed. Power per unit mass calculated for the small scale reactor, then this is translated into power

needed in the new reactor, which can then be used to calculate the rpm needed in order to maintain a constant power per unit volume.

The second available method of scaling up a reactor is to maintain a constant mixing time. Using the mixing equation above, the mixing time can be calculated for the smaller reactor. This can then be equated to an equation of the second reactor, and power per unit volume can be solved for. From power per unit volume, the Power input of the reactor required to maintain constant mixing time can be solved for. This then produces the result of the impeller speed which can be multiplied by 60 to produce required to maintain a constant mixing time between different scales.

Another constant which can be maintained across mixing scales is constant impeller tip speed. This method is similar to the constant mixing time, however better accounts for differences in the impeller styles. This method uses the equation:

$$\pi N_1 D_1 = \pi N_2 D_2$$

With the variables remaining the same as stated earlier.

### The CR-60 Reactor Vessel

The CR-60 reactor vessel is designed and sold by Büchi AG, headquartered in Uster, Switzerland. The CR-60 itself is part of the larger CR range of reactors, including also 15L, 30L, 100L, 160L, and 250L size options. All of the CR reactors feature a glass-lined steel bottom, and are designed to accommodate a wide range of chemical processes. A transparent midsection allows the operator to observe the process inside the vessel. A schematic of the CR series is given as Figure 3, with the CR-60 shown in the middle. The rightmost reactor in Figure 3 demonstrates the various parts of the reactor with

a key given in Figure 4. Figure 4 also contain the interior dimensions of the CR-60 reactor.

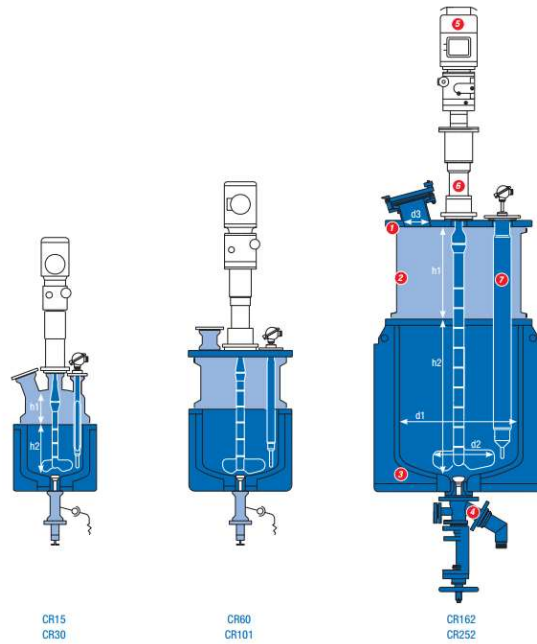

Figure 3 Schematics for the Buchi CR Series Reactors

Reactor vessels of CR «chemReactor» /		CR 15	CR 30	CR 60	CR 101	CR 162	CR 252
d1 (DN)	mm	300	400	400	400	600	600
d2	mm	175	250	250	250	360	360
d3	mm	75	75	75	75	125	125
h1	mm	170	230	260	410	460	460
h2	mm	270	200	350	540	485	790

- ① Cover: Glass dome / or glass lined steel cover plate
- ② Glass column
- ③ Glass lined, jacketed bottom heating section
- ④ Bottom valve: Dead volume free, flush mounted
- ⑤ Agitator: Powerful drive with speed variation
- ⑥ Shaft sealing: Dry running, double acting
- ⑦ Baffle with Pt100

Figure 4 Dimensions for the Buchi CR Series Reactors

The CR-60 possesses a low clearance agitator designed for low volume mixing applications. The impeller schematic, including dimensions, is included as Appendix D.

## Methodology

### Phenolphthalein

One of the two core areas of focus of the project was locating and profiling mixing zones within an agitated vessel. To do so, the team relied heavily upon decolorization techniques. Among them, the team performed a series of experiments with an acid-base neutralization reaction with a phenolphthalein indicator.

The team used potassium hydroxide flakes, acquired from Sigma Aldrich, and hydrochloric acid from Millipore. The hydrochloric acid, SKU HX0603, was provided at an unknown concentration because Millipore protects their concentration as a trade secret<sup>4</sup>. Nevertheless, a titration indicated that the hydrochloric acid was at a concentration of approximately 11.4M. The phenolphthalein source was unknown and was supplied from the WPI stockroom.

For each experiment, the team mixed a solution of 0.1 M KOH in deionized water and used the acid at stock concentration. The phenolphthalein was left otherwise unmodified.

---

<sup>4</sup> Reference to another section of the report

The team ran trials at the 500 mL and 250 mL scale. For every experiment, the reactor was filled to capacity with 0.1M KOH. The team created each 0.1M solution per trial by massing flakes of KOH. To this, the team added a small (<0.5g) quantity of phenolphthalein<sup>5</sup>. As a result, the trial started with a reactor of bright pink liquid. The team set the impeller speed to variable rpms.

Before the trial started, the team started a camera to record the experiment and started a stopwatch within view of the camera to measure mixing time more accurately. With the recording equipment started, the team began the trial.

To the stirred bulk phase, the team added a 10% excess of hydrochloric acid through surface addition with a beaker<sup>6</sup>. Each surface addition entered through the top port of the reactor with as small of an addition time as possible. When the pink color completely vanished from the bulk phase, the team terminated the recording.

## Methylene Blue

The methylene blue method was based on a method described in Ecole Polytechniques's proposed Unit Operations Experiment (Ascanio et Al). This method called for the creation of a 10% methylene blue dye in an aqueous corn syrup solution of roughly 1.5cPa. This dye was

---

<sup>5</sup> The phenolphthalein indicates equally well for most small, detectable values. As such, the team did not control directly for the amount added.

<sup>6</sup> Mention the need for pipettes for the 250 mL

added to a larger amount of the aqueous corn syrup at a rate of about 1ml dye per liter solution. The team modified this procedure by using water as a base material instead of corn syrup.

The diluted methylene blue dye solution used by the team consisted of 10mL methylene blue (1.5 weight percent aqueous solution, Sigma-Aldrich 03978) added to 90mL of water. The team then prepared the reaction with an amount equal to the maximum volume of the reactor. For the base of the reaction, DI water was used in an amount equal to the maximum volume of the vessel which the trial was being performed on. The volume of the methylene blue was varied slightly, as the team varied the volumes of the methylene blue in order to create a better image. The team determined that the ideal volume of methylene blue would create a color in the reactor that was darker than the background of the reactor. This volume fell in the range of 1.25-1.5mL of diluted methylene blue solution/1L water in the reactor.

Methylene blue was added via a variable volume pipette. Addition time for the method was approximately 1 second. This addition time varied, but the team avoided significant jetting of the dye in order to maintain pure surface addition. Avoidance of jetting by the addition stream was done by removing the pipette tip slowly from the pipette with the methylene blue dye remaining in the tip. Removal of the tip created a slow leak which allowed for the material to drip into the reactor vessel.

Mixing time was measured from the point at which methylene blue first entered the reactor until the point at which the entire reactor volume reached the same blue shade. Video data were also collected in order to verify exact starting and ending times.

The methylene blue colorization mixing time provided the team with insight of mixing time as modeled by Dynochem. Through the method, the team was able to determine some of the assumptions which Dynochem made in the mixing time model used by the team.

The results were interpreted by comparing the measured mixing time to the mixing time which was produced by replicating the reactor vessel in Dynochem when the operational parameters were put in. This difference was turned into a percent difference between the measured and Dynochem times, with Dynochem time being held as the correct time.

### Thermocouple

After using both acid-base decolorization and methylene blue colorization method to determine last mixed zones and mixing time, the team worked to develop a method which uses two volumes of water at different temperatures to determine mixing time.

Temperatures were measured using thermocouples connected to the QuickDAQ software. The thermocouples were connected to the computer through a Data Translation DT9828 connection hub. Data collection in the QuickDAQ software was set to run continuously at a rate of 200 hz.

Three thermocouples were used in this method. The team placed the thermocouples based upon the results of the decolorization experiment data. The placement of the thermocouples relative to the geometry of the vessel remained roughly similar across all trials. One thermocouple was placed slightly above the top of the impeller as it was meant to represent a middle mixing point. Another thermocouple, used to determine when the reactor finished mixing, was placed next to the impeller shaft roughly  $1/5$  of the distance from the surface of the



liquid to the bottom of the impeller. The final thermocouple was placed to act as an indicator of mixing in the reactor. This thermocouple was placed in a location roughly half the distance between the impeller shaft and the reactor wall, at roughly half of the tank height.

The volumes of water added varied from trial to trial, but the approximate volumes were kept consistent throughout each run. The reason for some variability in the volumes was due to the high volume required and the lack of the ability to add volumes in a fast enough time frame.

DI water from the source was placed in the 500mL reactor vessel at a volume of roughly 450 mL. Another volume of DI water was heated to approximately 70 °C. Once the heated volume reached a desirable temperature, the hot water was poured into a smaller container and added to the cold water as rapidly as possible. Roughly 1 second before hot water addition, data collection was started on all three thermocouples. Before addition the temperature of the hot and cold water was recorded. The volume of the hot water was roughly 50mL, the true value being the amount required to bring the reactor volume to the 500mL marking. These two approximate volumes were then recorded. The trial was considered finished at the point which the impeller thermocouple and the shaft thermocouple reached the same temperature as the thermocouple placed in the bulk volume.

Analysis of the results and determination of the final mixing time was done by plotting the collected thermocouple data. The point at which the system was considered mixed was when the graph of the three plots intersected, as this represented equal temperatures for all thermocouples.

While Dynochem was not able to accurately account for the longer mixing time and predict accurate mixing times, the team was able to confirm that the thermocouple mixing times measured were close to accurate. As a proof of concept, the team prepared a two-fold mixing experiment. This experiment combined the thermocouple method with the methylene blue method and allowed the team to recognize that the thermocouple method was measuring an accurate mixing time. The experiment done involved taking the 10% methylene blue dye and placing 1mL, the amount used for the 500mL reactor, into the water which was heated for the thermocouple method. The experiment was performed similarly to the thermocouple experiment, with the exception that both temperature from the thermocouples and colored mixing zones were observed.

### Scaling Up with Dynochem

The process for scaling up a reactor and predicting mixing time using Dynochem follows three primary steps. The first step is to input the base reactor. The base reactor is the reactor used for the methylene blue experiment. The reactor vessel dimensions need for the Dynochem model are: Tank Diameter, Tank Height, RPM, Impeller Style, Clearance of Impeller from the bottom of the reactor, impeller style, impeller clearance. These reactor dimensions are capable of manual insertion or there are a collection of reactors available prebuilt in the Dynochem library. The liquid properties needed for the calculation are density and viscosity.

Once the first reactor is input into Dynochem, the same process is repeated for the scale-up reactor. The same variables are needed, except for the RPM the larger reactor is operating at. The Dynochem input and results screen are seen in Figure 5 and Figure 6.

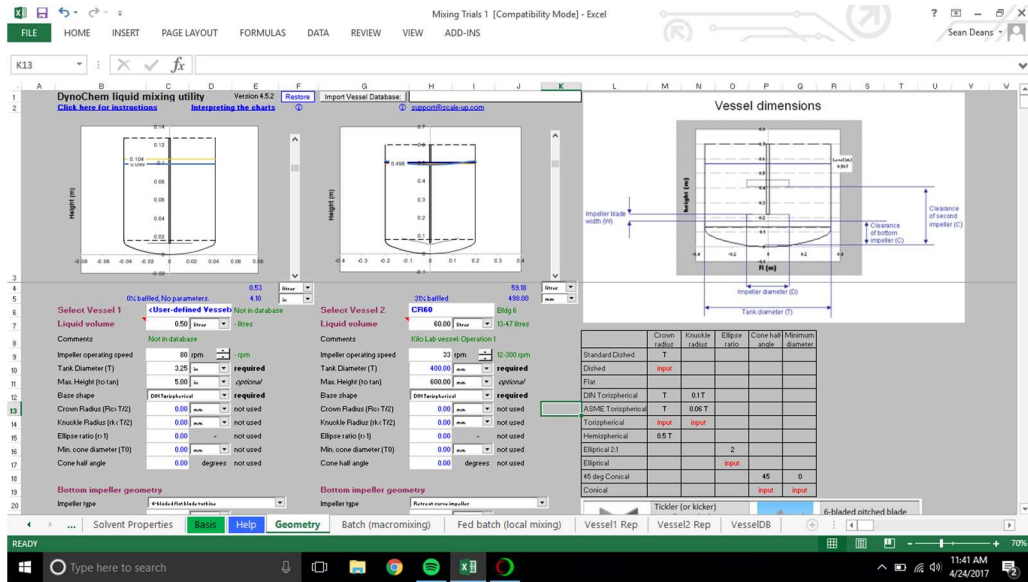

Figure 5 Screenshot of Dynochem Input Screen in "Liquid-Liquid-DBS.xls"

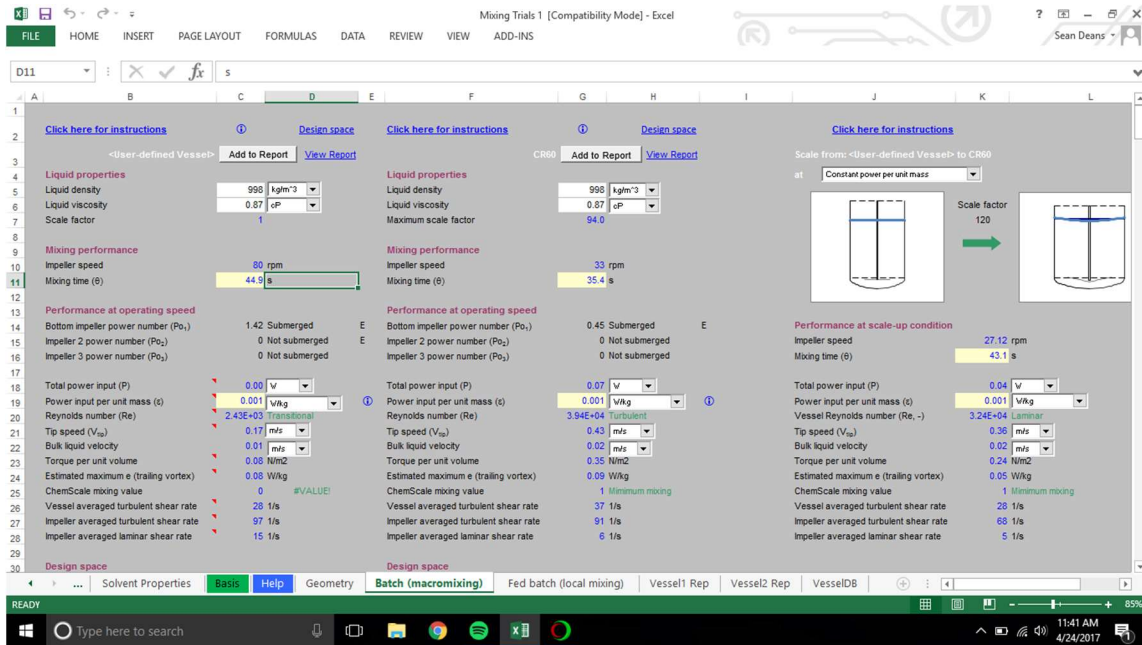

Figure 6 Screenshot of Dynochem Results Screen in "Liquid-Liquid-DBS.xls"

With both reactor vessels input into Dynochem, the next step for the prediction of mixing time on a larger scale is to determine the factor to use for scale up. The Dynochem model used in this project features the ability to calculate scale up following one of eight different methods. The method that review of literature and observation has suggested to follow is the method of maintaining constant power per unit volume.

After the 2 vessels and scale up method are put into Dynochem, the model produces either an RPM or mixing time depending on the scale up method chosen by the user.

## Experimental Set-Up

### 250 mL Reactor

The 250 mL Reactor used for experimentation was a Globe series reactor from Syrris. This reactor contains a jacket, unused by the team, which provides heating or cooling to the reactor. Additionally, this reactor was connected to a Heidolph RZR 2051 Control motor which was capable of measuring both RPM and power output. This reactor also featured 6 inlets of various sizes on the lid of the reactor which the team utilized reagent addition as well as thermocouple entry. The reactor also had a singular drain port located at the bottom of the reactor.

### 500mL Reactor

The 500 mL Reactor used for experimentation was another Globe series reactor from Syrris. The reactor vessel was similar to the 250 mL reactor, including a jacket. A Heidolph RZT 2052 Control motor was connected to the 500 mL reactor.

## 3L Reactor

For the 3L experiments, a Mobius 3L CellReady Single-Use Bioreactor was used. While intended for singular use, the team reused the same reactor vessel as there were no permanently staining or damaging agents used in any of the experiments performed. This reactor features a singular straight baffle with 1.0 inches of clearance from the bottom. The reactor itself featured several external drainage and addition ports located on the lower quarter of the vessel, with 3 addition ports located on the removable lid of the vessel. A variable output motor found within the lab was connected to the built-in impeller of the reactor vessel. An Omega Pocket Tach was used to determine the RPM of the motor as it did not have any way to measure the RPM's. The motor had some small performance errors, namely moments of inconsistent RPM output, however this was corrected for by the team through multiple measurements throughout all trials.

## Decolorization Set-Up: 250 mL Scale

For the acid-base decolorization experiment, 2 ring stands, 1 camera, 1 stopwatch, and the previously mentioned 250mL reactor were used, as well as 11.4M hydrochloric acid and Potassium Hydroxide flakes. The physical set up consisted of a ring stand located at a position which enabled the entire reactor to be recorded with the camera. The camera was then affixed in this ring stand. A stop watch was affixed to the other ring stand and placed next to the reactor in a way which enabled it to be within the camera recording. Within the same fume hood of the reactor the hydrochloric acid was kept and transferred to the reactor via a pipette. The potassium hydroxide flakes were kept measured using a scale and dissolved in a 1 liter beaker. An overhead schematic can be seen in Figure 7.

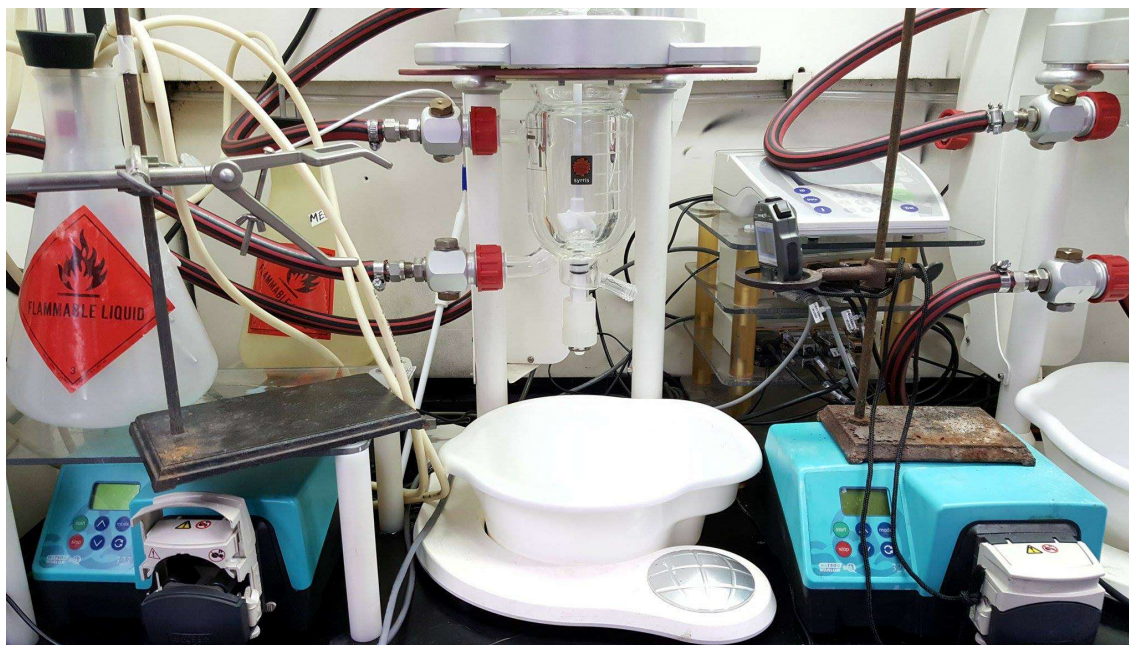

Figure 7 The experimental setup for the 250mL decolorization experiment.

A similar set up was used with the methylene blue experiments. The only difference was in material usage. A 100mL beaker housed the diluted dye and the dye was transferred into the reactor via a pipette.

#### Decolorization Set-Up: 500 mL Scale

The 500 mL acid-base decolorization and methylene blue experiments used the same supplies as the 250 mL experiments, with the exception that the 500 mL reactor was used in place of the 250 mL reactor. A picture of the reactor can be seen in Figure 8, and an overhead schematic can be seen in Appendix A.

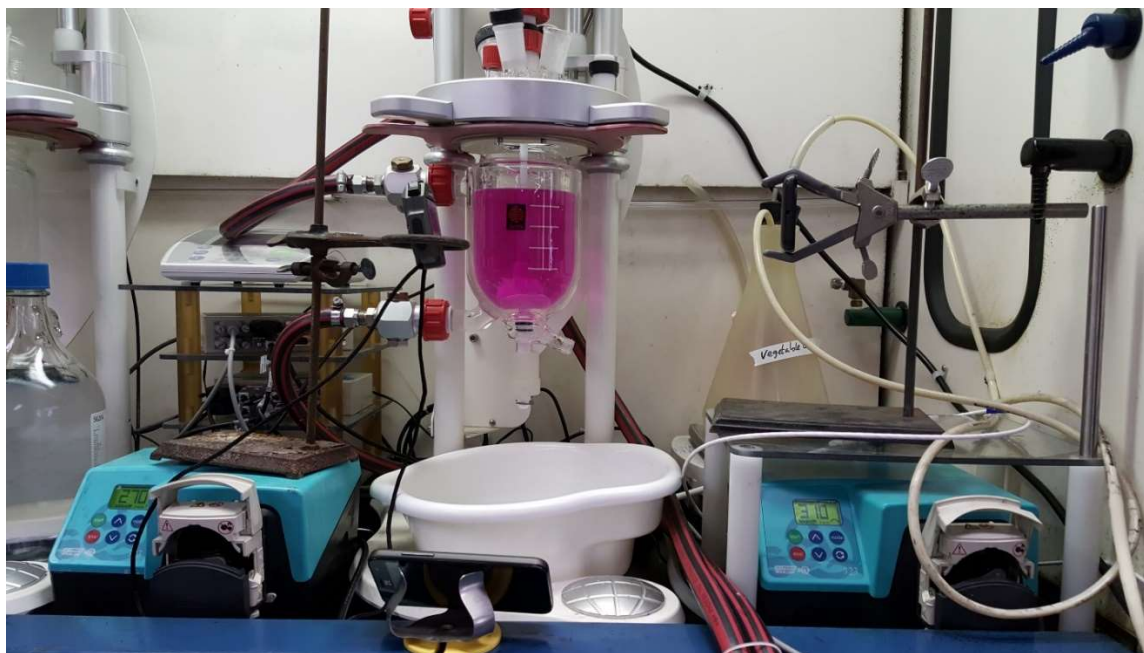

Figure 8: 500mL decolorization experimental setup

### Decolorization Set-Up: 3L Scale

On the 3L scale, no acid-base decolorization was done as the acid used for the experiments would have severely damaged the plastic reactor vessel. The supplies used in the methylene blue experiments on the 3L were similar to the previous 2 experiments, with the addition of 2 flashlights, a white backdrop, and an additional ring stand included. The camera was affixed to a ring stand and placed at a distance which allowed total viewing of the reactor vessel. In order to improve the visibility of the dye, a large piece of white paper was placed behind the reactor vessel and two flashlights were positioned to shine light down into the reactor. The motor was affixed to a ring stand secured to the platform housing the reactor vessel and was lowered into position for all trials. The stop watch was located similarly, being near enough to

the vessel to be included in the recording taken by the camera. A picture of the set up can be seen in Figure 9 and an overhead schematic can be seen in Appendix A.

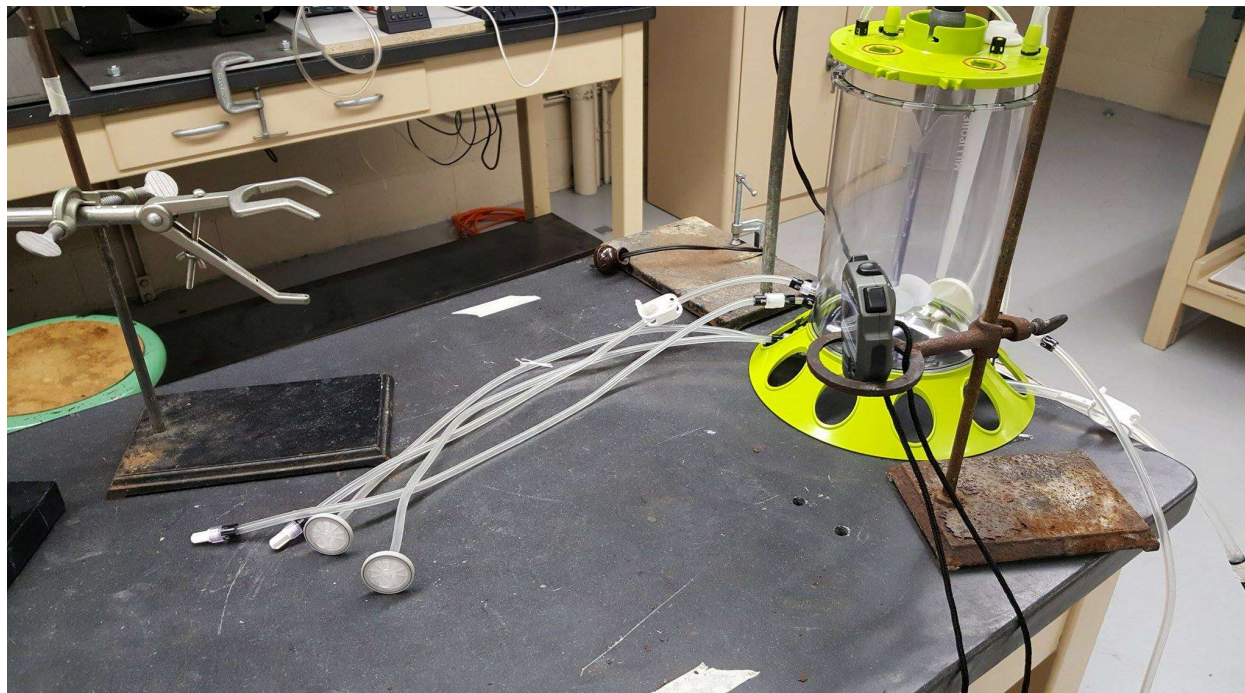

Figure 9 The experimental setup for the 3L decolorization experiment

### Thermocouple Set-Up: 500mL Scale

For the 500mL set up, three thermocouples were placed into the reactor. One thermocouple, connected to Channel 1 of the data acquisition hub, was placed at a location near the outside of the reactor at the halfway height. The position was held by using a combination of electrical tape and plugs to shorten the length of the thermocouple entering the vessel. A second reactor, connected to Channel 2 of the data acquisition hub, was placed so that it was collecting data from the location right above the impeller in the reactor. This thermocouple was held in its position with a similar method as the first thermocouple. The third and final thermocouple was connected to Channel 3 of the data acquisition hub and was placed so that it was collecting data



from right next to the impeller shaft at a height near the surface of the water, but no lower than 1/5 of the length of the shaft away. The third impeller was also held in place using electrical tape and specific plugs. The hot water was added via funnel addition and was poured from an 80mL beaker. A picture of the set up can be seen in Figure 10 and an overhead schematic can be seen in Appendix A.



Figure 10 The Experimental Setup of the 500mL Thermocouple experiments

### Thermocouple Set-Up: 3L Scale

The thermocouple for the 3L scale used a similar set up to the 500mL scale, with some minor differences. Primarily, the thermocouples were held in their positions with ring stands and clamps rather than plugs and electrical tape. One ring stand was used per thermocouple to allow for maximum choice in placement. The overall position of the thermocouples did not vary from

the 500mL scale. One thermocouple was placed at roughly half the height near the edge of the reactor, one thermocouple was placed directly above the impeller, and the third impeller was located directly next to the impeller shaft within the top 1/5 of the reactor vessel. The only limitation to this was that the shaft thermocouple should be located below the level of the cool water in order to prevent noise from the addition of the hot water. A 400 mL beaker was also used for the funnel addition of the hot water. A picture of the set up can be seen in Figure 11 and an overhead schematic of the set up can be seen in Appendix A.



Figure 11 The experimental setup for the 3L thermocouple experiment

## Results

### Methylene Blue: 250mL Scale

The methylene blue experiments were performed at 60 RPM on the 250 mL scale. On the 250mL scale, the average measured mixing time was 31.7s over 5 trials. When these times

were compared to the Dynochem predicted times, the average error for all trials was 8.22%. The data for all trial is seen in Table 1.

Table 1 The results for the 250mL Methylene Blue experiments

Trial	Vessel	Start Time	End Time	Mixing Time	Dynochem Time	%Difference
1	250	18.77	52.84	34.07	32	0.06
2	250	24.39	53.59	29.2	32	0.09
3	250	12.78	47.44	34.66	32	0.08
4	250	16.18	45.18	29	32	0.09

### Methylene Blue: 500mL Scale

On the 500 mL scale, the rpm of the motor was held constant at 80 RPM per trial. Across these trials the mixing time was an average of 48.1s for 5 trials. This included two trials which appeared to be outside, or to have other errors. Across the 3 trials which appear to have performed correctly, the mixing time was an average of 47.5s.

When comparing the measured mixing time to the Dynochem predicted models, the 5 trials error was 28.0%, and the three trial error was 28.9%. This rror was calculated by taking the absolute value of the difference of the Dynochem predicted time and the measured mixing time and diving them by the Dynochem mixing time. Noticing that there was a high % error, the team investigated the variables which affect mixing time in Dynochem to attempt to produce similar mixing times. Discussed later, the team simulated the results with a 1.75” impeller in Dynochem. This produced a difference of 13.5% for the 5 trial average and a % difference of 5.4% in the 3 trial average. The full data table can be seen in Table 2.

Table 2 The results for the 500mL Methylene Blue experiments

Trial	Vessel	Start Time	End Time	Mixing Time	Dynochem Time	Dynochem 1.75	%Difference	1.75 %Difference
1	500	28.88	66.28	37.4	66.8	45.1	0.44	0.17
2	500	23.88	70.89	47.01	66.8	45.1	0.30	0.04
3	500	18.79	64.47	45.68	66.8	45.1	0.32	0.01
4	500	65.39	115.24	49.85	66.8	45.1	0.25	0.11
5	500	30.69	91.34	60.65	66.8	45.1	0.09	0.34

### Methylene Blue: 3L Scale

On the 3L scale, the motor rpm across 5 trials varied between 77 and 88 RPM. This places all trials in transitional Reynolds number regime. On average, the mixing time measured by the team was within 12% of the mixing time predicted by Dynochem. One exception to this occurred in a trial at 77 RPM at which the mixing time was measured at 22.89s. Dynochem predicted a mixing time of 31.2s, leading to a difference of 26.63%. The full data table can be seen in Table 3

Table 3 The results for the 3L Methylene Blue experiments

Trial	Time (s)	RPM	Dynochem Time (s)	% Difference
1	22.89	78	31.2	0.27
2	28.56	86	25.7	0.11
3	21.73	88	24.6	0.12
4	27.04	85	26.5	0.02
5	33.63	77	32	0.05

### Thermocouple: 500mL Scale

For the 500 mL thermocouple experiments the data were analyzed and mixing time was determined by find the points at which the difference in the temperatures were within both 1% and 5%. These would correspond to 99% mixed and 95% mixed, respectively. On average, the

99% mixing time was 14.18s with a range of 10.07s-18.46s. The average 95% mixing time was 7.58s with a range of 5.54s-12.05s. These wide ranges suggest an inconsistent system, discussed later. The trial recordings and trial times are found in the tables below.

Table 4 The trial records for the 500mL thermocouple experiments

Trial	Hot Temp (°C)	Cold Temp (°C)	Hot Volume (mL)	Cold Volume (mL)	RPM
1	48	21	50	450	80
2	65	20.8	80	450	80
3	63	21	50	450	80
4	66	21	50	450	80
5	68	21.7	50	450	80
6	66	21.5	25	475	80

Table 5 The results for the 500mL thermocouple experiments

Trial	Start	End 5%	End 1%	Time 5% (s)	Time 1% (s)
1	8.15	13.69	18.22	5.54	10.07
2	9.5	19.53	25.4	10.03	15.9
3	8.81	14.26	20.91	5.45	12.1
4	4.59	10.8	23.05	6.21	18.46
5	2.3	8.52	14.47	6.22	12.17
6	2.19	14.24	18.59	12.05	16.4

### Thermocouple: 3L Scale

The 3L thermocouple mixing time was calculated similarly as the 500mL thermocouple method. The average 3L 95% mixing time was 11.70s with a range of 9.72s-15.05s. This includes 1 trial which was recorded as having a long mixing time. With this run excluded, the average mixing time was 10.86 with a range of 9.72s-12.5s. The average 95% mixing time with

the long addition trial was 23.756s with a range of 20.58s-27.1s. With the longer addition run removed, the average mixing time is 23.28s with a range of 20.58s-27.1s. With the range remaining the same, it is suggested that the longer addition time does not have as significant an effect on the 99% mixing time, discussed later. Results and data trials can be seen in the tables below.

Table 6 The trial records for the 3L thermocouple experiments

Trial	Hot Volume Added (mL)	Cold Volume (mL)	Hot Temp (°C)	Cold Temp (°C)	Rpm
1	300	2700	68.2	21.6	80
2	150	2850	79.8	21.8	80
3	150	2850	78.2	21.9	85
4	150	2850	79.2	21.9	86
5	150	2850	78.9	21.9	86

Table 7 The results for the 3L thermocouple experiments

Trial	Start	End 5%	End 1%	Time 5% (s)	Time 1% (s)
1	2.32	17.37	27.99	15.05	25.67
2	3.5	13.39	27.91	9.89	24.41
3	2.78	14.1	29.88	11.32	27.1
4	2.29	14.79	22.87	12.5	20.58
5	2.2	11.92	23.22	9.72	21.02

### Phenolphthalein: 250mL Scale

On the phenolphthalein 250 mL trial, the average mixing time across the 3 trials which contained usable data were 26.35s. This average time had a difference of 17.66% compared with the Dynochem prediction. This trial had a large amount of variance, with one trial having a difference of 34%. Some trials of the video were contaminated due to excess base left over in the

feed port of the reactor. This caused the added hydrochloric acid to reach a pH which was unable to decolor the phenolphthalein. The results of the trials are seen in Table 8.

Table 8 The results for the 250mL phenolphthalein experiments

Trial	Vessel	Start Time	End Time	Mixing Time (s)	Dynochem Time (s)	% Difference
1	250	60.66	88.26	27.6	32	0.14
2	250	36.97	67.28	30.31	32	0.05
3	250	36.43	57.58	21.15	32	0.34

### Phenolphthalein: 500mL Scale

For the 500mL phenolphthalein trials, a similar approach to the 500 mL methylene blue trials were used. This approach being that both the actual impeller and the 1.75” impeller were used to calculate the Dynochem mixing time and percent difference. For the 1.5” impeller, the average mixing time was 28.98s, which had a 56.6% difference from the predicted Dynochem mixing time. For the 1.75” impeller, percent difference of the measured mixing time from the Dynochem mixing time did not perform much better, as the average difference was 35.75%. The summary of the results can be seen in Table 9.

Table 9 The results of the 500mL phenolphthalein experiment

Trial	Vessel	Start Time	End Time	Mixing Time (s)	Dynochem Time (s)	Dynochem 1.75 (s)	% Difference	1.75 %Difference
1	500	58.68	86.94	28.26	66.8	45.1	0.58	0.37
2	500	55.79	77.09	21.3	66.8	45.1	0.68	0.53
3	500	65.79	92.28	26.49	66.8	45.1	0.60	0.41
4	500	53.38	88.69	35.31	66.8	45.1	0.47	0.22
5	500	44.89	77.99	33.1	66.8	45.1	0.50	0.27

6	500	46.98	76.37	29.39	66.8	45.1	0.56	0.35
---	-----	-------	-------	-------	------	------	------	------

## CR60 Scale Up Results

In Table 10, the results for the scale up to the CR60 are seen based upon 3 different factors. Constant mixing time seems to produce the fastest mixing time, however this comes with the requirement for a much an RPM nearly twice as large as the other two scale up methods. If the RPM is manageable, the faster mixing time could be favorable, however due to the larger power requirement, this method may not be as desirable. The constant power per unit mass and constant impeller tip speed function in similar ranges of time, only varying by 5.9s and 4.4RPM. This indicates that constant impeller tip speed is usable if power input is a primary concern, as it requires less power input for a roughly similar mixing time.

Table 10 The Collection of Results for the CR60 Scale Up

Scale Up Condition	Condition Value	Mixing Time	Required RPM
Constant Power per Unit Mass	.001w/kg	42.0s	27.8
Constant Mixing Time	27.4s	27.4s	42.7
Constant Impeller Tip Speed	.32m/s	47.9s	24.4



## Thermocouple Placement on The CR60

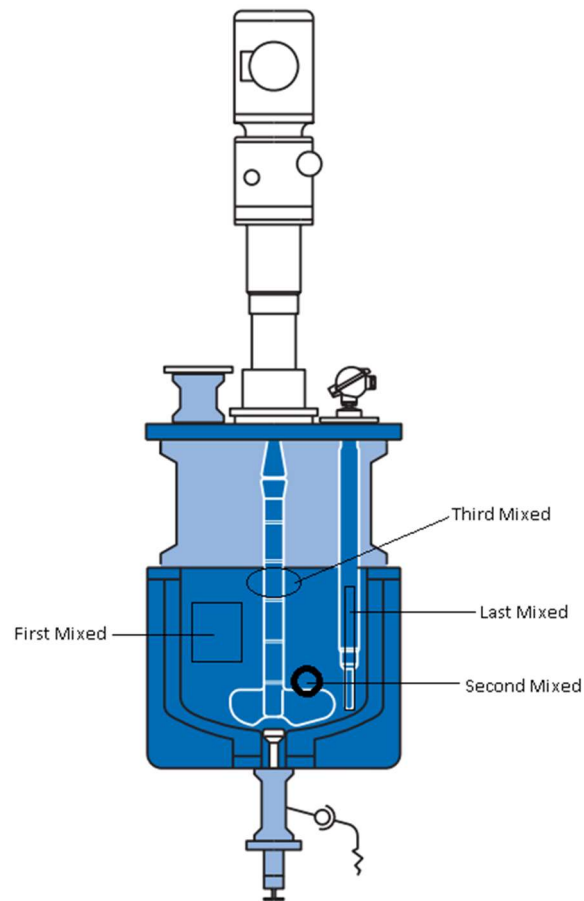

Figure 12: Schematic of CR60 with Thermocouple Placement Indicated

Based upon the results of both the methylene blue experiments and phenolphthalein experiments, the figure above shows the areas where thermocouples should be placed in order to determine mixing time. One note of the above figure is that the suggested thermocouple placement zones are dependent upon the liquid height in the reactor. Above, the assumption is that the surface of the liquid is located at the top of the dark blue area. The rule to follow is that

the “First Mixed” Thermocouple is located in at a height equal to half the liquid height, and located roughly halfway between the impeller and reactor wall. The “Third Mixed” thermocouple is located within the top fifth of the liquid height, directly next to the impeller. The “Second Mixed” Thermocouple is placed directly above the impeller and as close to the shaft as is feasible. While the team did not explore any thermocouples placed on or near baffles, literature suggests that this zone would be the last mixed zone in a reactor. As the team did not explore it, the team does not know what heights may work, simply that a thermocouple should be located on the baffle, with the thermocouple placed on the side of the baffle opposite the flow.

## Discussion / Analysis

As the team performed experiments, several interesting patterns emerged. What follows is first an overview of our general findings. After that follows the discussion of specific methods, methylene blue, decolorization, and TDWS; a discussion of the efficacy of DynoChem; a brief overview of a particle tracing method that the team investigated; a discussion concerning how Sunovion’s desired operating conditions may alter which methods they use to model mixing; and finally a recap of certain topics which the project could not directly address.

### General patterns

Although the team selected its three primary methods because they work in different ways, there are still nevertheless similarities between them. The team isolated a few effects of special note to discuss.

### Addition time

Where the team operated on relatively small scales, the order of magnitude of the addition time was often to the same scale as the order of magnitude of the overall mixing time. In a certain sense, this is unavoidable given the scales on which the team did experimentation. When the measured mixing time is on the scale of seconds to tens of seconds, most every addition time will be non-negligible. However, this does not necessarily invalidate or call into question the validity of the results. Rather, it most precisely means that, in the absence of a carefully controlled addition time, one ought to expect a high variance in mixing times. In the absence of such a control, a varying addition time will very directly impact the resulting mixing time.

The effect of addition time is much more pronounced when the size of the addition phase is large when compared to the bulk phase, as we note below. This means that, while addition time ought to be considered across all of the methods employed, it is a particularly relevant consideration for methods such as TDWS which have addition phases on the order of magnitude of the bulk phase.

### Location of addition

The team noticed that the location of addition can impact both mixing time and the location of mixing regions within the vessel. With radial symmetry, the radial position from the axis of rotation becomes the most important variable. However, without radial symmetry, e.g. in the presence of baffling, one must consider both the radial position from the axis of rotation as well as the absolute location within the vessel.

The team did not collect a set of data to control for the radial position. Rather, the team attempted to add all liquids halfway between the impeller and the tank wall. While it is possible to collect a series of data to study the effect of addition location in-depth, the team chose instead to investigate the methods more broadly. The team wished to understand what variables were most important to control rather than to attempt to control only one or two variables to the neglect of discovering more features of each method.

In addition, it is not yet clear the degree to which addition location needs to be meaningfully controlled. It is possible that, in actuality, addition location only accounts for a slight change in mixing time and/or mixing zones. Or, it is also possible that Sunovion's use of the CR-60 reactor takes place with a fixed addition location. If this is the case, then there is no particular need to study the effects of addition location as there is no variance in addition location in real application.

#### Size of bulk phase relative to the mixing phase

Careful consideration of the relative sizes of the mixing phase and the bulk phase constitutes one of the most important choices in final decisions concerning which methods to implement. At one extreme, a negligible addition volume means that the mixing dynamics of the bulk phase will likely not noticeably change. The vessel can already be considered fully-developed in this situation, which is significantly easier to understand and model. At the other extreme, the addition phase may be larger than the bulk phase (though the name "bulk phase" would not necessarily apply here). If this is the case, then the entire mixing profile of the vessel will likely be disturbed and re-settle in a different way. In this case, it is difficult to predict how the vessel will settle as to do so requires modeling complex turbulence patterns.

The distinction between these two extremes became relevant as the team compared the different methods it tested. The difference is especially pronounced when one tries to use DynoChem to model mixing times, as discussed below.

#### Liquid density, relative liquid densities

As the densities of the bulk phase and addition phase vary, so too will the mixing behavior. For example, if the addition phase is significantly denser than the addition phase, it will sink as it is added. For reaction-based mixing, this will likely result in a quicker mixing time than if the two phases were of an equal density. However, in the case of immiscible liquids, it is also possible that a dense addition phase will also stagnate on the bottom instead of mixing at all. This is itself a function of impeller placement as well, and a general solution to the problem becomes quite complicated.

If, on the other hand, the addition phase is significantly less dense than the bulk phase, then the addition phase will likely float on top, provided the turbulence is not extreme, and will slow the mixing time. Again, it is difficult to describe the behavior more specifically because the exact variance of mixing dynamics with density differentiation is itself a complicated network of other variables. The behavior is not one dimensional. However, it is still a parameter which demands attention because it can result in significant changes in mixing time as it is varied.

#### Decolorization

Phenolphthalein decolorization produced a series of videos which show clearly the relative mixing speeds in the reactor vessel. The team performed experiments only on the 250 mL and 500 mL scale, neglecting the 3L scale. Because the 3L vessel is made from

polycarbonate, the team feared that the concentrated hydrochloric acid would eat through the vessel and cause structural failure.

Decolorization is particularly useful for demonstrating the different mixing zones in the reactor. However, this method does not necessarily give a good account for overall mixing time in the vessel. The team noticed that, upon addition, the added acid began to sink immediately towards the bottom of the vessel, owing to its greater density than the bulk phase. This falling action allowed quicker mixing, resulting in the shorter experimental mixing times than would be anticipated by DynoChem modeling. Nonetheless, the team still believes that, because the vessel did not mix uniformly from top to bottom as the acid sunk, the experiment still adequately demonstrates the location of different mixing zones. The acid still had to be circulated by the action of the impeller in order to mix. Thus, despite a more rapid mixing time, the mechanism of mixing is still the work of the impeller rather than natural convection. The team believes it is reasonable to conclude, then, that phenolphthalein decolorization is an appropriate tool to locate mixing zones to be measured with another method.

Phenolphthalein is just one among other techniques for decolorization in a vessel. There may be other methods which do not suffer from the stark density differences between the two phases in this particular method. However, it is not accurate to say that the phenolphthalein method is deficient because of the density differentiation. Indeed, it is quite possible that an operator will, for their actual mixing process, be mixing two phases of different density. If this is the case, then perhaps it is better that the team's implementation of the phenolphthalein method is not with two equally dense phases.

Dr. Zhang from Sunovion proposed a decolorization method involving sodium thiosulfate, iodine, and starch providing in Appendix 1. The team chose not to perform sets of experiments with this method owing to the high cost of the reagents and the difficulty with preparing stock bottles of sodium thiosulfate. Instead, the team believed it sufficient to demonstrate that decolorization is in general a viable approach to the problem. Specific implementation is contingent on the actual reagents mixed in the CR-60.

Despite this, there are still a few meaningful points of comparison between the sodium thiosulfate and phenolphthalein methods which are worth mentioning. The sodium thiosulfate method involves safer reagents as compared to the 11 M HCl which the team used. Although iodine is toxic, it is not nearly as hazardous when spilled as is concentrated HCl. While safer, sodium thiosulfate is also more difficult to work with. Dr. Zhang's procedure calls for 5 M solutions of sodium thiosulfate. Upon preparation, the team found that the solution has a propensity to suddenly precipitate from solution. Because the solution must be prepared with heated and constantly stirred water, the team found it time-consuming to prepare solutions on a trial by trial basis and feared the consequences of precipitation in the reactor vessel.

The team's procedure for phenolphthalein decolorization is substantially cheaper to implement. Sunovion has previously expressed that they find it cost-prohibitive to perform sodium thiosulfate decolorization on the full 60 L scale of the CR-60 reactor. Per our estimates, Sunovion can perform a phenolphthalein decolorization on the 60 L scale for between \$15-\$25 per trial with materials sourced from Millipore and Sigma Aldrich.

It should be noted as well that decolorization relies on being able to see the inside of the vessel as it is being tested. Thus, it is ineffective for opaquely jacketed reactors. However, as Sunovion seems to favor Dr. Zhang's decolorization as a tool, the team deduces that an inability to see into the reactor is likely not an issue.

## Methylene Blue Dye

Mixing methylene blue dye into a water bulk phase is an effective method to measure mixing time in such a way that it matches constraints of DynoChem (see below). The technique is especially effective in that it is cheap, simple to perform, and can be executed quickly. Methylene blue dye is also non-toxic, which obviates the need for special handling or disposal, unlike the other decolorization methods.

The team found the best results when adding approximately 1.2 mL of a 10x dilution of the original Sigma methylene blue dye 1.5 weight percent aqueous solution per 1 L of water. Too much more dye resulted in cloudiness and too much less was too difficult to differentiate from the water itself.

While methylene blue dye can be used to observe an overall mixing time, it is difficult to spot mixing zones using the dye. In phenolphthalein decolorization, mixing zones are easy to spot because they remain colored whereas the mixed zones of the reactor turn clear. The opposite is true for methylene blue. Careful analysis of a video of the process could still allow one to observe mixing zones, but only provided they are not hidden behind or within regions of blue dye. In other words, if the dye spreads to the outside of the vessel, it will potentially obscure the



clear regions of the vessel behind it, whereas in phenolphthalein decolorization, only the slow mixing zones stay visible.

Like decolorization, methylene blue dye only works when an operator has a clear view of the entire vessel. The team assumes that this is the case for the vessels that Sunovion wishes to experiment with, given its interest in decolorization via Dr. Zhang's protocol.

## TDWS

The core premise of the project was to evaluate the viability of TDWS, particularly the ability to predict the behavior of TDWS in the CR-60 as a function of its behavior in smaller vessels. As the result of experimentation, the team believes that, while TDWS is an internally consistent method, it is difficult to implement. There are several serious considerations prior to the implementation of TDWS.

First, TDWS is asynchronous with DynoChem. DynoChem's modeling utilities have a series of assumptions about the mixing process that are necessary for it to accurately calculate mixing time (see below). However, TDWS' implementation falls outside of the necessary parameters. Thus, while still appears to be a valid approach to measuring mixing time in a reactor, it is difficult to couple TDWS with DynoChem-friendly methods, such as methylene blue dye mixing.

TDWS is asynchronous with DynoChem because of the relatively large size of the addition phase needed to cause a significant change in the temperature of the bulk phase. TDWS only works when the temperature change in the vessel is large enough to be easily noticeable on thermocouples. The signal needs to be clear and differentiable from the noise associated with

such a process. To do so requires a large addition phase of hot water compared to the size of the bulk phase. Where the liquid added in the methylene blue dye method is negligible, it must be considered in TDWS. There is nothing deficient in this either; in fact, this may more closely resemble the actual operating conditions in the CR-60. However, it does make comparison with DynoChem almost impossible.

In addition, it is not certain whether or not bulk motion or conduction dominates in TDWS. Sunovion has expressed that their interest in TDWS lies in the fact that they believe TDWS models bulk flow. However, the team is not certain that this is the case. The team was unable to concretely determine the prevalence of one type of transport over the other, but nevertheless the question of the speed of conductive forces versus bulk motion bears heavily on the ability of TDWS to meet Sunovion's expectations.

Finally, where visual methods can be recorded and re-watched so as to precisely determine the beginning of addition and the end of mixing, TDWS is limited by the responsiveness of the thermocouples used. However, this is likely not a serious limitation as many thermocouples have a response time on the order of fractions of seconds compared to mixing times on the order of tens of seconds. While not a crippling limitation, it still must be considered for a successful implementation.

Despite some serious difficulties with TDWS, it also enjoys several key benefits. First and foremost, it is exceptionally inexpensive to test with. Aside from an initial capital cost related to thermocouples, testing software, and so forth, the actual experimental trials can take place for effectively free. In addition, the team imagines that *in situ* measurement with TDWS is easier than for most other methods. As long as the reagents are not intensely heat sensitive,

Sunovion could heat one of the streams and then use TWDS to monitor the extent of mixing. TDWS *in situ* testing also leaves no other components behind, unlike for decolorization or methylene blue dye.

## Dynochem

DynoChem is a useful software for both predicting mixing times in a given reactor vessel as well as scaling results from a smaller reactor to a larger one. However, while DynoChem is useful, it has some serious limitations as a software. These limitations can be worked around, given certain operational setups, but nevertheless pose serious challenges toward implementation.

First and foremost, DynoChem, as of the time of this report, has only one utility, Liquid-Liquid\_DB, which predicts mixing time. As such, if DynoChem is to be used in such a capacity, it must be in such a way that it mirrors the type of model that this utility uses. Crucially, the model operates under the assumption that the addition to the bulk phase is of a negligibly small size and that the addition phase has the same physical properties as the bulk phase. For certain methods, such as methylene blue dye addition, this assumption is very close to true. However, for others like TDWS, the assumption does not hold. In order for there to be a detectable change in bulk phase temperature, TDWS relies on a relatively large addition in proportion to the bulk phase. Thus, as is reflected in the results, DynoChem's mixing time predictions are relatively close for methylene blue, but are quite divergent from TDWS. The team concludes from this that DynoChem's internal model relies heavily on this core assumption.

As a result, using DynoChem requires additional considerations. Nevertheless, Sunovion has expressed great interest in incorporating DynoChem into the team's final recommendations. The team believes that DynoChem is a productive tool for this purpose, but that it may require supplementation in order to match the actual mixing conditions in the CR-60.

DynoChem's particular use comes in creating a 2-layer confirmation of mixing times by supplementing another measurement method. For example, where the methylene blue method operates under the same conditions as DynoChem's internal model, one can be reasonably sure of the mixing time if both DynoChem's prediction and the actual mixing time of methylene blue in a vessel agree with one another.

### Operational Conditions

Underscoring many of the considerations presented above is the potential large range of conditions under which Sunovion could operate their CR-60. Where predictive capability over mixing in a reactor is contingent on knowledge of the first-order effects outlined in the background chapter, it is difficult to say not only what the mixing dynamics may look like in the vessel, but also which method for determining the mixing dynamics will work most effectively, as the methods themselves are partially contingent on the dynamics as well.

The very problem itself is to a greater or lesser extent dependent on the conditions of the reactor for the possible mixing setups. For example, if the residence time in the reactor greatly exceeds the measured mixing time, it is not altogether clear that a precise monitoring method is necessary. If this is the case, then it may be reasonable to simply perform a methylene blue dye

experiment directly on the CR-60 and, if the mixing time is sufficiently short compared to residence time, choose not to implement TDWS or any other similar method.

Similarly, if Sunovion requires precision on the scale of fractions of seconds owing to chemical kinetics, side reactions, etc., then certain of our methods may be inadequate and perhaps a higher fidelity method is needed.

### Particle Tracing

There exist many other methods for studying mixing in a vessel, several of which the team has already outlined in the background chapter. In addition to the three methods, methylene blue dye, phenolphthalein decolorization, and TDWS, the team began cursory investigation of a particle tracing method. Particle tracing is useful in that it allows the operator to follow the path of a particle throughout the vessel, allowing study of the actual motion of the addition phase once added. Realizing the potential use for this method in studying the development of discrete mixing zones, the team attempted to produce an easy-to-implement method to track particle motion in a vessel. While the team ultimately chose to abandon this method due to time restrictions, an account is nevertheless included as a point of interest and to possibly guide future work.

The created methodology was relatively simple. An operator would fill the mixing vessel to an operational height using water, set the impeller to a desired rpm, and then either add a multitude of dark tracer particles, or just one, to the bulk phase. Tracer particles needed to be dark, but could be composed of any material such as paper, plastic, or so on. The operator would record the mixture with a camera. In the case of just one particle, the operator would take

multiple videos, removing the added particle each time and then re-adding it to the same location.

In order to trace particle motion, the team created a script with the Perl programming language. The script would take a video source and decompose it into individual frames using the tool ffmpeg. Then, the script would automatically process each of the frames with the ImageMagick suite. The program would appropriately mask, blur, and threshold the image such that all that remained of the image was a series of dark regions corresponding to the tracer particles. In the case of a mass addition, the output could either have been images progressively overlain on one another, demonstrating all of the zones which had experienced mixing, or simply a series of images showing the actual motion of the cloud of tracer particles through the bulk phase. In the case of a repeated single addition, the program could do the same, but this time for the purpose of following the probabilistic motion of an individual particle at a certain location, which may provide insight into the development of mixing zones.

Ultimately, the team chose not to proceed with this method for several reasons. First, given time limitations, it was not clear that the team would be able to process the results of such a method in a meaningful way given the amount of statistical work anticipated. The other methods investigated seemed as though they would yield more readily-accessible results. Secondly, the team had difficulty finding tracer particles which moved “naturally” through the water in a way which the team imagined individual soluble molecules might. If the results of this method are to be useful, then the particles have to move in a way that somewhat mirrors the true motion of the addition phase. Thirdly, the team was unsure of how useful the program would be even if it had produced meaningful results. Where the team created the program itself, the end

result was not easily usable by someone not familiar with the program's internal structure. Given more time, the team could have produced a more user-friendly version, but ultimately the team chose instead to focus its efforts on clearer paths. As such, the team collected no data using the created program.

Nevertheless, the result was a proof of concept which, given further study could supplement, or perhaps even supplant, the other methods investigated.

### Recap, Including Weaknesses in Assessment

It should be re-noted that the team's approach has centered on outlining a series of empirical methods which can be used to model mixing in the CR-60 vessel. The team chose this approach because of its flexibility, given especially that Sunovion may operate over a large range of conditions. While the team thinks that this approach is a good one, it still nevertheless came with limitations, especially concerning the ability to derive results from first principles. The gap is especially noticeable concerning predictive power over mixing zones within the vessel. As stated above, the team attempted to remedy this gap using a particle tracing approach, but found it beyond the boundary of the project scope.

Decolorization does demonstrate the different mixing zones within the vessel. However, the relationship between first-order mixing time effects and the development of discrete mixing zones is not immediately clear. In other words, although decolorization can be effectively used to locate mixing zones for the purpose of placing thermocouples in TDWS, decolorization does not necessarily help explain why those zones form in the locations that they do. The literature on the matter, as mentioned in the background chapter, is fairly scarce. The most sensible approach

seems to be experimentation with computational fluid dynamics using programs such as COMSOL. This is, however, assuming that Sunovion desires a more comprehensive knowledge of the emergence of different mixing zones. Such a knowledge may not be necessary, especially if Sunovion desires to only study the dynamics of the CR-60 vessel.

## Recommendations

The team has several recommendations for both Sunovion and for future research.

As a method of scaling up reactors, the team recommends a twofold approach to determine mixing time through thermocouple placement. The first step of this method is to determine mixing time of the vessel using a method such as the methylene blue dye experiment the team performed. A decolorization method such as the sodium thiosulfate could also determine mixing time, however the team recommends study into the method to allow for easier stock solutions to work with. The second step is to determine accurate mixing time using a high visibility method similar to the phenolphthalein method. Once proper mixing time and probe placement are determined, a Dynochem model is created that matches the mixing time of the small scale reactor and portrays the large scale reactor. With this Dynochem model, the large scale mixing time can be determined based upon a number of scale up factors. This mixing time is then confirmed using whichever method was used in the first step and second steps are repeated on the large scale. The first step mixing time should match the Dynochem predicted mixing time. With proper probe placement and determination that the probes are able to match



mixing time, the thermocouples can be placed and used to measure mixing time in thermally differentiated streams.

One recommendation of the for Sunovion is that another measuring probe potentially be explored over the thermocouple method. While the thermocouple method is able to accurately follow mixing time, the method itself bears some inconsistencies, such as addition time. A method using conductivity probes could function in place of thermocouples, and this method would allow for several advantages. Bulk motion having the primary effect on mixing is one such advantage. Similarly, a conductivity probe method would match the ease, accuracy, and affordability that is presented by a thermocouple method, while also allowing for a potentially more consistent method.

There are several mixing factors, methods, and scales that the team recommends future research into. The aforementioned conductivity method is one such method, as the specifics of the method would need determination before use. Scales between 500mL and 3L, as well as between 3L and 60L, also merit exploration, as the team was unable to determine if Dynochem could accurately measure and predict mixing times at these scales. Exploration of other scales may also allow for creation of a model which better predicts the scaling of reactor vessels. Additionally, the team only explored a singular impeller style, a singular rpm on each reactor, and a singular tank diameter to impeller diameter ratio. The team recommends exploration of these factors as they may show to have greater impacts on mixing time than the team predicts. Exploration of these factors and how they affect Dynochem scaling would also allow for greater understanding and accuracy of a method to scale reactors.



# Appendices

## Appendix A: Overhead Schematics of Experimental Setups

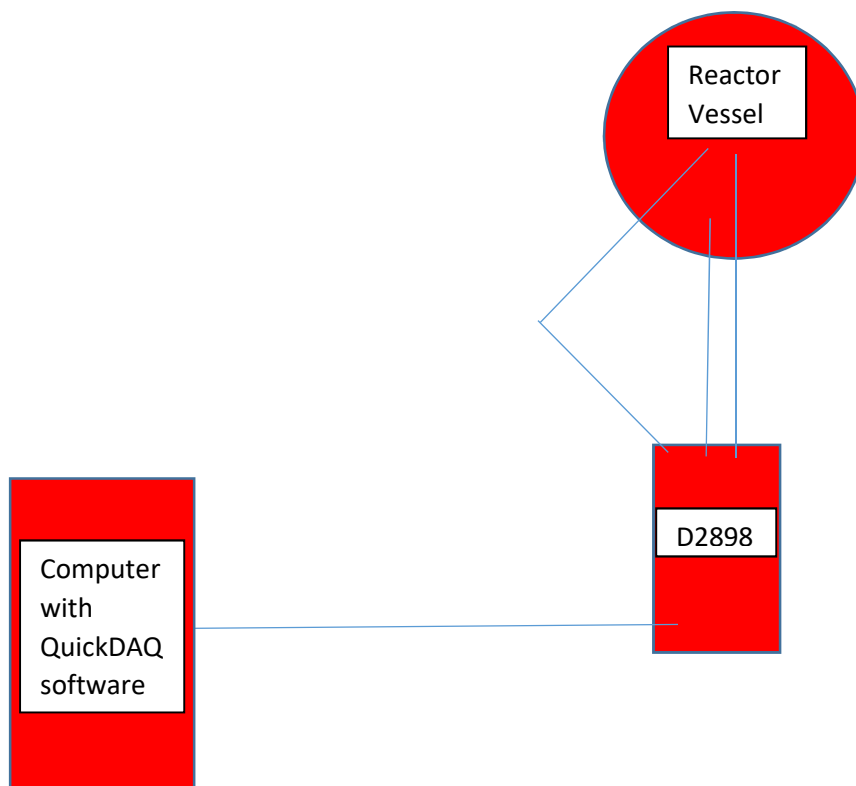

Appendix A.1 Overhead schematic of The Thermocouple experimental setup

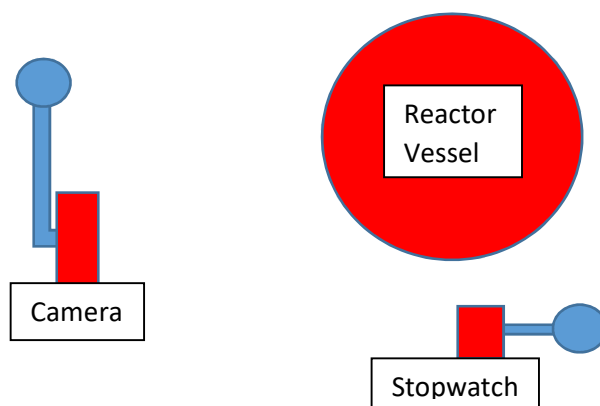

Appendix A.2 Overhead schematic of the Decolorization experimental setup

## Appendix B: Thermocouple Experimental Results

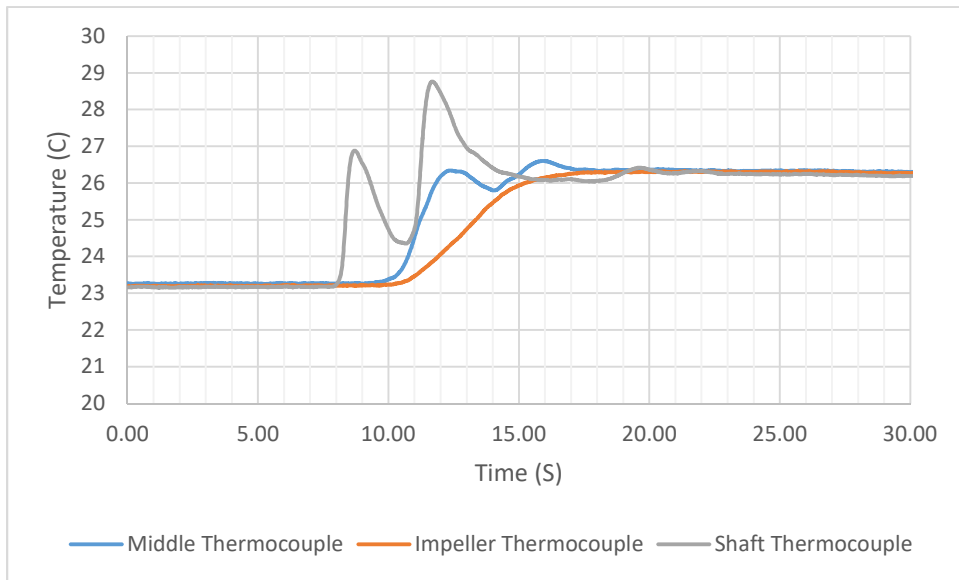

Appendix B.1 Thermocouple Data for Trial 1 on 500mL

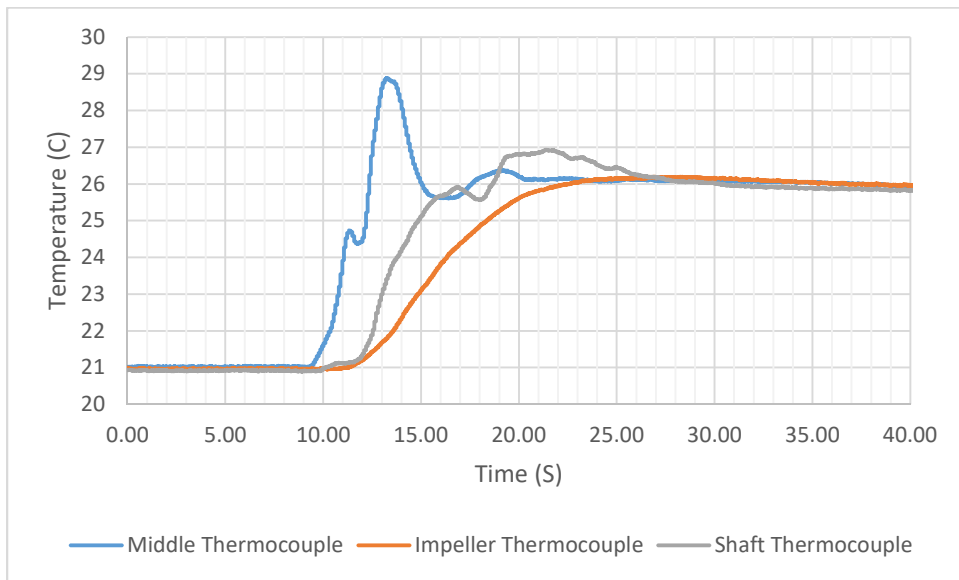

Appendix B.2 Thermocouple Data for Trial 2 on 500mL

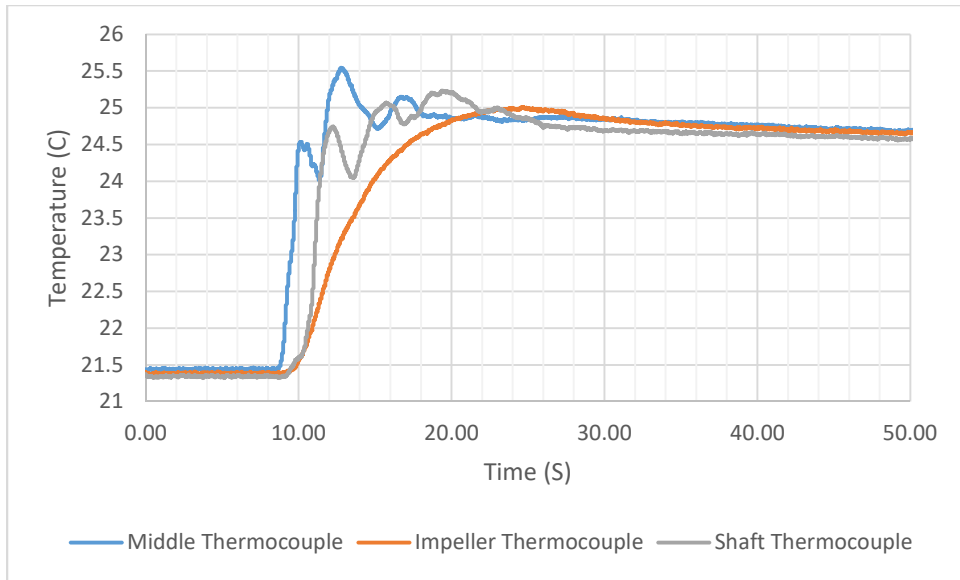

Appendix B.3 Thermocouple Data for Trial 3 on 500mL

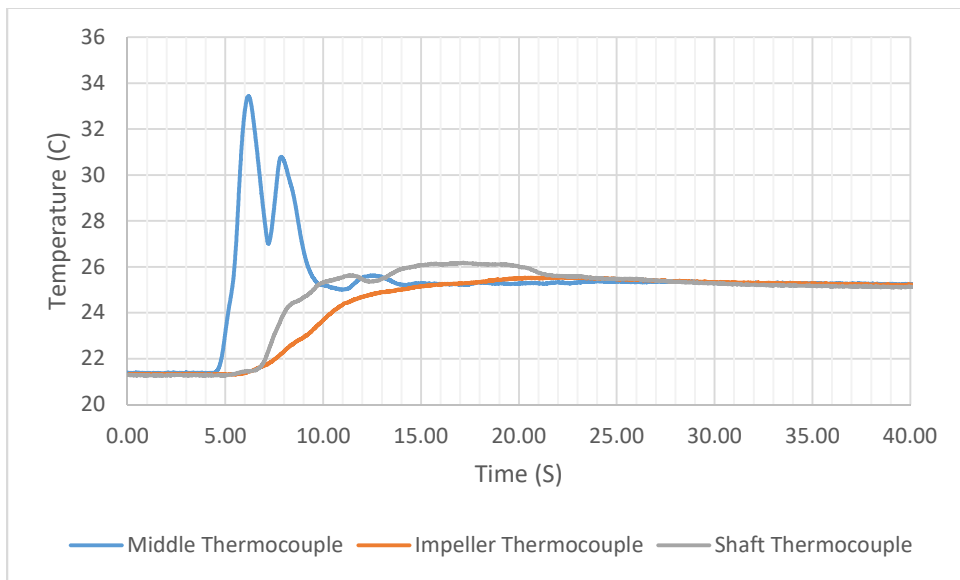

Appendix B.4 Thermocouple Data for Trial 4 on 500mL

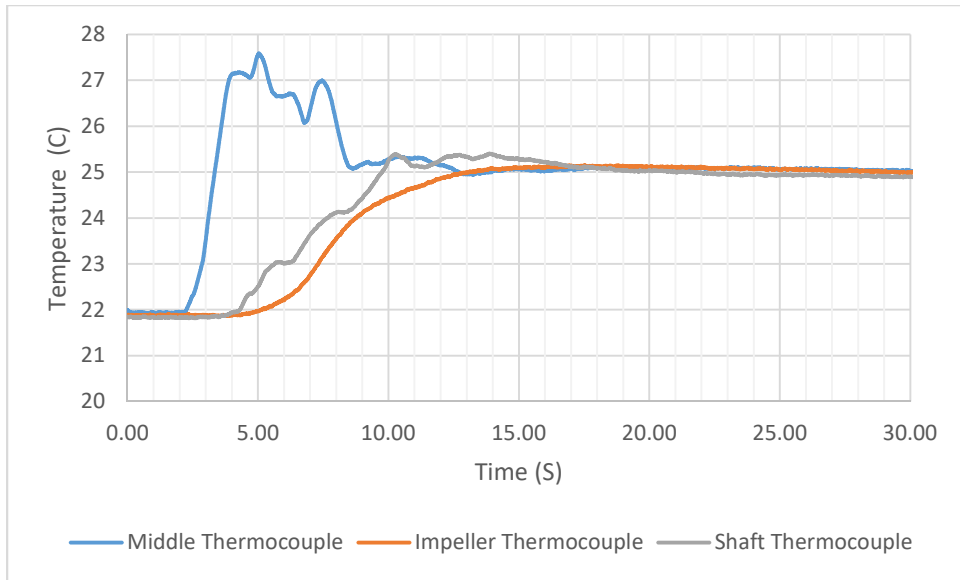

Appendix B.5 Thermocouple Data for Trial 5 on 500mL

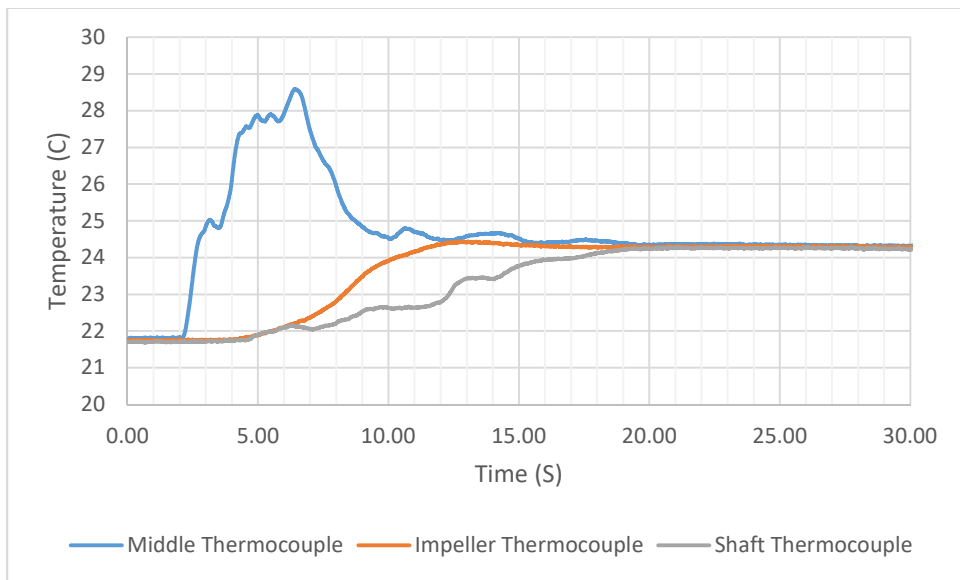

Appendix B.6 Thermocouple Data for Trial 6 on 500mL

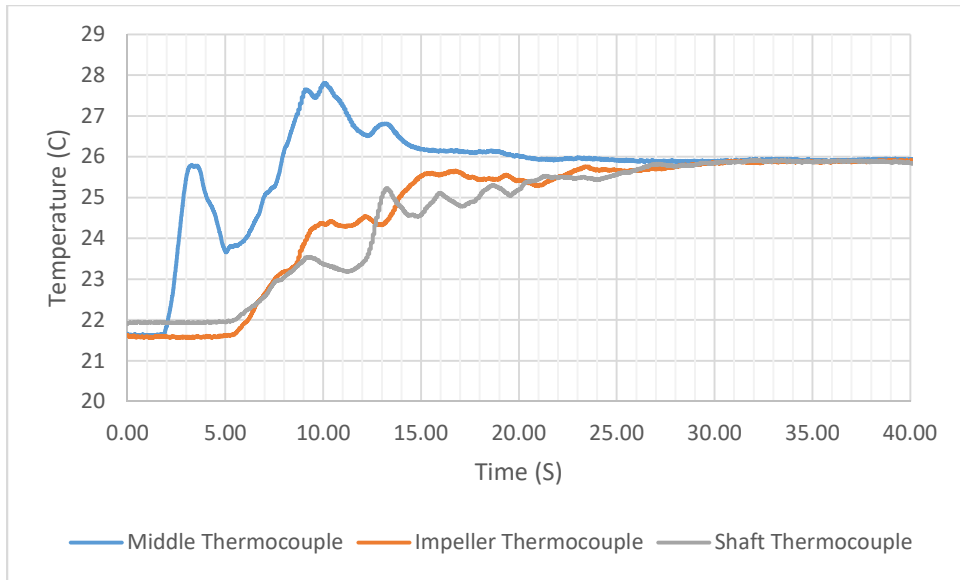

Appendix B.7 Thermocouple Data for Trial 1 on 3L

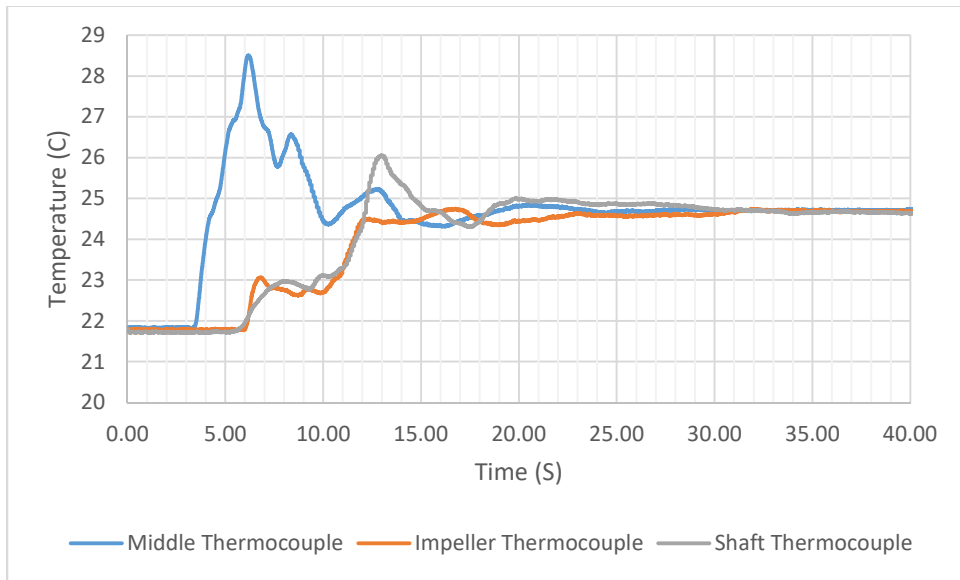

Appendix B.8 Thermocouple Data for Trial 2 on 3L

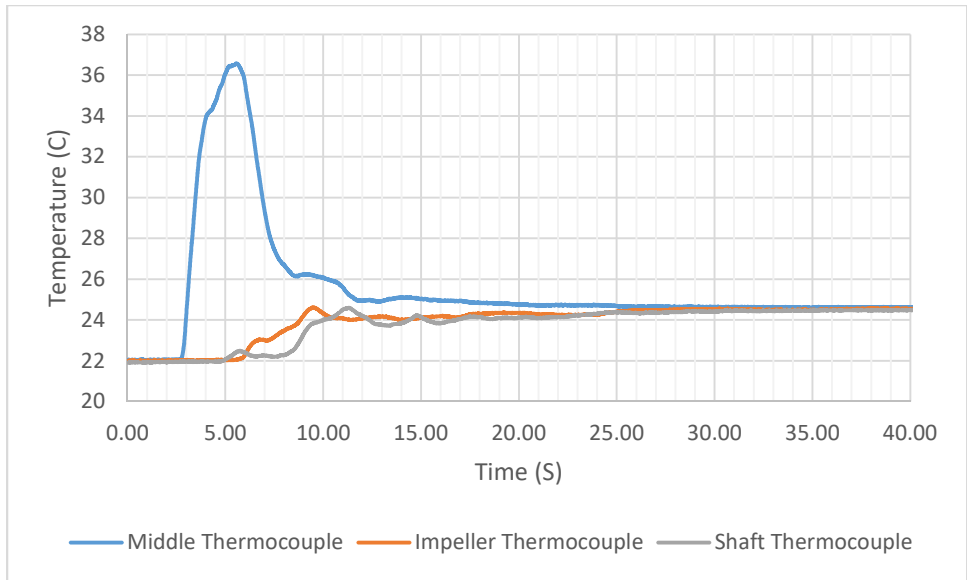

Appendix B.9 Thermocouple Data for Trial 3 on 3L

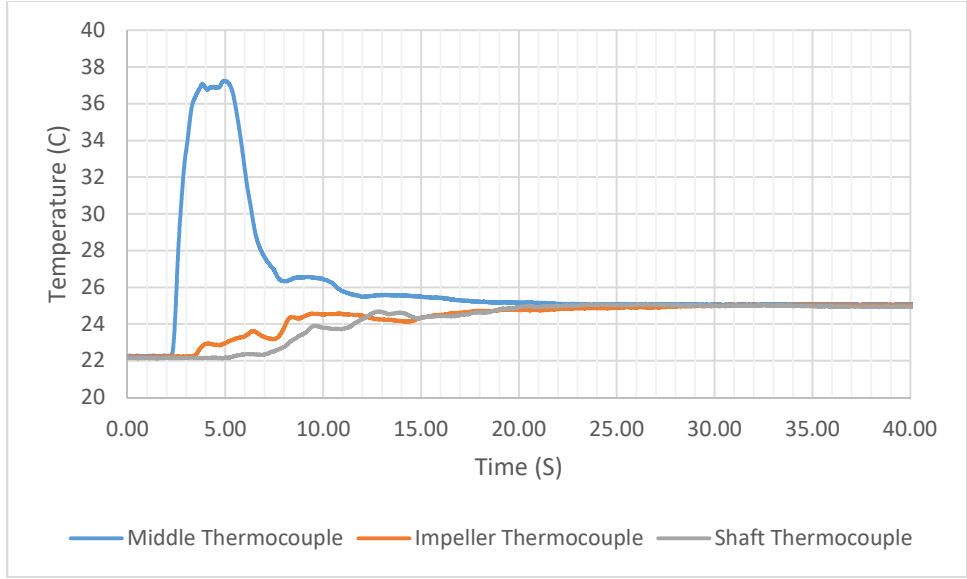

Appendix B.10 Thermocouple Data for Trial 4 on 3L



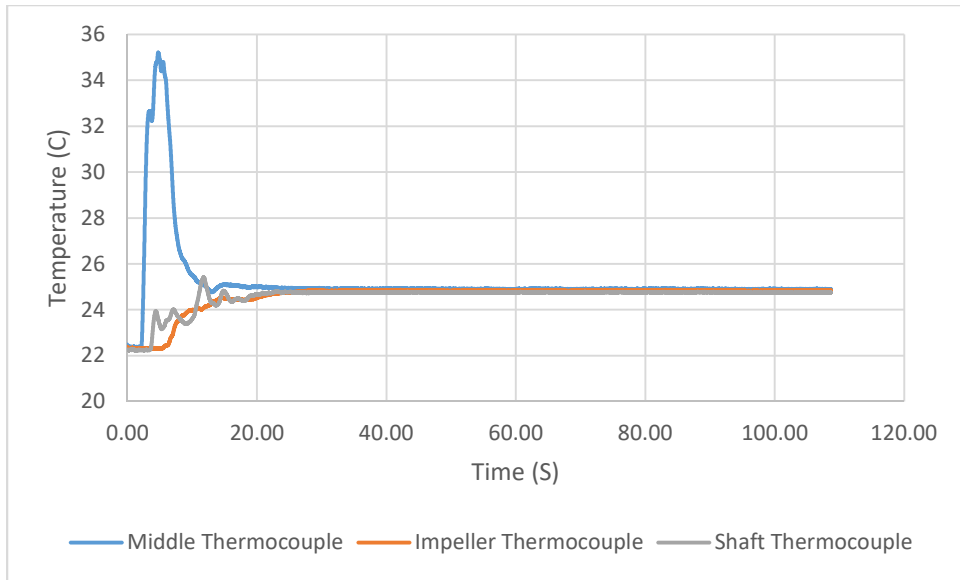

Appendix B.11 Thermocouple Data for Trial 5 on 3L

## Appendix C :Dr.Zhang’s Sodium Thiosulfate Decolorization Method

### **Decolorization Experiment for Determination of Appropriate Probe Locations in Phase I Mixing Studies**

**April 28, 2016**

Before quantitative determination of mixing parameters such as blend time, we must learn first where to place probes (*e.g.*, thermocouple, conductivity probe) in order to ensure that the resulting parameters reflect the least well---mixed regions in the vessel. To that end, we propose a straightforward decolorization experiment.

This experiment is a neutralization reaction; as the neutralization occurs during mixing, a blue---black color will disappear and traces of remaining color will be easily identified as poorly mixed regions. We assume that Sunovion will use no fewer than two probes for Phase I studies, so if exactly two are used the first should be placed in the impeller stream and the second should be placed in the most poorly mixed region. A recommended third probe could be placed in a well---mixed bulk region away from baffles and impellers about halfway around the fluid’s circulation loop.

#### *Reactor Configuration*

The reactor configuration includes the stirrer type, liquid height, baffle width, and other common STR dimensions. It is important that Sunovion capture these data accurately prior to experimentation and keep the values consistent across different experiments.

We expect to perform these experiments with the reactors configured according to their typical use (*e.g.*, with FBRM or ReactIR probes).

#### *Reagents*

The reagents required for this experiment are readily available and inexpensive:

1. 1% starch solution in water
2. 0.1 molar solution of iodine
3. 5 M solution of sodium thiosulfate

The starch solution is available directly from Sigma (for instance). The other solutions are easily prepared or purchased. If they are prepared immediately before use, there should be no stability concerns; otherwise, we should observe storage and handling procedures appropriate to each solution. In particular, the thiosulfate solution is light sensitive.

#### *Procedure (1 L scale)*

1. To a small beaker (say 50 mL), add 5 mL of starch solution.

2. Add a sufficient quantity (but no more) of the iodine solution in order to produce an intense black color. Call this volume  $A$ . (**NOTE**: an excess of iodine solution will degrade the starch.)
3. Add approximately  $2.5A$  of the thiosulfate solution to the beaker. Stir to ensure the blue---black color disappears.
4. To the 1 L reactor, add a volume of starch solution equal to  $5/(3.5A+5)$  L.
5. Add a volume of iodine solution equal to  $A/(3.5A+5)$  L.
6. Begin stirring the reactor at the desired speed.
7. Quickly add a volume of thiosulfate solution equal to  $2.5A/(3.5A+5)$  L.
8. Observe where the final traces of color are located in the reactor. (Video recording the event would be useful.)

The procedure for the 69 L Buchi reactor in principle would be run the same way.

### *Discussion*

The stirring speed should be set depending on the flow regime of interest; *e.g.*, for turbulent mixing, the stirring speed should be such that the Reynolds number  $\rho ND^2/\mu$  is no less than 4000 - 10000. (stirring speed: 59 – 147 rpm)

Preparing large quantities of the solutions may preclude running this experiment in the Buchi reactor. In that case, it is suggested to place the probes in the Buchi reactor in a way that is consistent with the findings from the decolorization experiment at the 1 L scale.

Appendix D: Schematic of the Impeller in the CR-60 Reactor

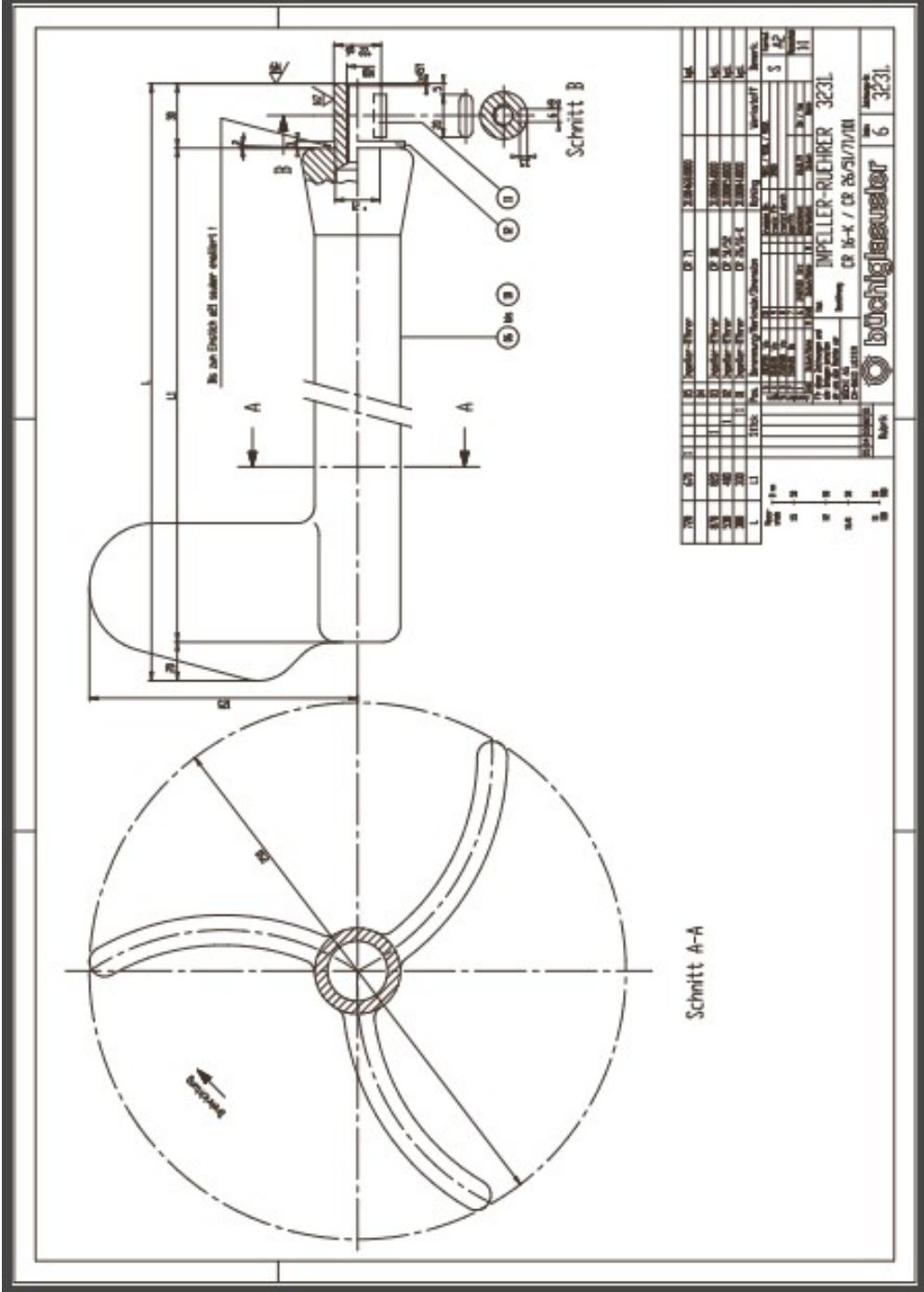

## References

- Ascanio, Gabriel. "Mixing time in stirred vessels: A review of experimental techniques." *Chinese Journal of Chemical Engineering* 23.7 (2015): 1065-076. Web.
- Ascanio, Gabriel, Robert Legros, and Philippe A. Tanguy. "A Fluid-Mixing Laboratory for ChE Undergraduates." (n.d.): n. pag. A FLUID-MIXING LABORATORY FOR ChE UNDERGRADUATES. Ecole Polytechnique. Web. 22 Mar. 2017.
- Cooke, Mike. *DESIGN OF MECHANICALLY AGITATED CONTACTORS OR REACTORS WITH "ATTITUDE"*. Thesis. The University of Manchester, 2005. N.p.: n.p., n.d. Print.
- Dickin, Fraser, and Mi Wang. "Electrical resistance tomography for process applications." *Measurement Science and Technology* 7.3 (1996): 247-60. Web.
- Fasano, J. B., A. Bakker, and W. R. Penney. "Advanced Impeller Geometry Boosts Liquid Agitation." *Chemical Engineering* August (1994): n. pag. Web.
- Khang, Soon J., and Octave Levenspiel. "New scale-up and design method for stirrer agitated batch mixing vessels." *Chemical Engineering Science* 31.7 (1976): 569-77. Web.
- Lee, K.c., and M. Yianneskis. "A Liquid Crystal Thermographic Technique for the Measurement of Mixing Characteristics in Stirred Vessels." *Chemical Engineering Research and Design* 75.8 (1997): 746-54. Web.
- Mory, Mahieu. *Fluid Mechanics for Chemical Engineering*. N.p.: John Wiley & Sons, 2011. Print.
- Nere, Nandkishor K., Ashwin W. Patwardhan, and Jyeshtharaj B. Joshi. "Liquid-Phase Mixing in Stirred Vessels: Turbulent Flow Regime." *Industrial & Engineering Chemistry Research* 42.17 (2003): 4146. Web.
- Patwardhan, Ashwin W., and Jyeshtharaj B. Joshi. "Relation between Flow Pattern and Blending in Stirred Tanks." *Industrial & Engineering Chemistry Research* 38.8 (1999): 3131-143. Web.
- Quaessi, Fawzi A. Hamadi al-. *Mixing of two miscible liquids with high viscosity and density difference in semi-batch and batch reactors - CFD simulations and experiments*. Thesis. Duisburg, Essen, University, Diss, n.d. N.p.: n.p., n.d. Print.
- When performance matters «chemReactors» for kilolab and pilot plant*. Uster: Büchi Glas Uster, n.d. PDF. Accessed from <https://www.buchiglas.com/en/products/glass-reactors-plants-pilot-plants/reactor-systems-5-250-liter/chemreactor-cr.html>