

Project Number: MQF-IQP-2125

Improving Ambulance Power Systems

An Interactive Qualifying Project

Submitted to the Faculty of the

WORCESTER POLYTECHNIC INSTITUTE

In partial fulfillment of the requirements for the degree of

Bachelor of Science

by

Daniil Effraimidis

Mechanical Engineering

Nathan Fournier

Mechanical Engineering

Brian Jennings

Mechanical Engineering

Michael Perruccio

Management Information Systems

MIRAD Laboratory, April 30, 2013

Approved by:

Professor Mustapha S. Fofana, PhD, Advisor

Director of MIRAD Laboratory, Mechanical Engineering Department

## **Abstract**

Ambulances are often the last hope for life in critical medical situations. In order for an ambulance to safely transport a patient to the hospital, the patient may receive a variety of medical treatments. Many of these treatments require the use of the devices which rely on electrical power. The possibility of an ambulance not supplying enough power to medical devices is a major concern, resulting in a need for more reliable and efficient systems. To address this problem, the overall power consumption of an ambulance was calculated and compared to the actual electrical requirements. Alternate forms of power generation which could be utilized within an ambulance are discussed, in order to implement a more efficient power system. Among the most commercially viable solutions are the instillation of LED lighting to reduce overall power consumption, utilizing lithium ion batteries for efficient and sustainably energy production, and the integration of solar panels to effectively absorb additional energy. These options all provide realistic solutions to the prevention of ambulance power system inadequacies.

## TABLE OF CONTENTS

<i>Abstract</i>	i
<i>Table of Contents</i>	ii
<i>List of Figures</i>	iii
<i>List of Tables</i>	v
<b>CHAPTER 1 EMS POWER SYSTEM IMPROVEMENT</b>	1
1. Introduction	1
<b>CHAPTER 2. SUFFICIENT POWER SUPPLY IN EMS CARE</b>	3
2. Introduction	3
2.1 Typical Ambulance Power Consumption	5
2.2 Ambulance Design Criteria	7
2.2.1 Electrical and Battery System Criteria	9
2.2.2 Lighting - Interior and Exterior	12
2.2.3 Communications	17
2.2.4 Air Conditioning	19
2.2.5 Rescue Equipment	20
<b>CHAPTER 3. CONCEPTS FOR IMPROVEMENT</b>	23
3. Introduction	23
3.1 Ideas for Improvement	23
3.2.1 Fuel Cells	24
3.2.2 Solar Panels	34
3.2.3 LED Lighting	43
3.2.4 Air Turbines	51
3.2.5 Lithium Ion Batteries	54
<b>CHAPTER 4 CONCLUDING REMARKS</b>	78
<b>REFERENCES</b>	81
<b>APPENDIX A</b>	84
<b>APPENDIX B</b>	88
<b>APPENDIX C</b>	98
<b>APPENDIX D</b>	118

## List of Figures

Figure 1 – Power Consumption Break-Down.....	4
Figure 2 – Power Consumption Pie Chart .....	6
Figure 3 – Formulation of NFPA 1917 Standard .....	8
Figure 4 - 12 Volt DC Electrical System .....	10
Figure 5 - 125 Volt AC Electrical System .....	11
Figure 6 - Rear Ambulance Lights.....	13
Figure 7 - Front Ambulance Lights .....	13
Figure 8 - Ambulance Flash Pattern [1].....	14
Figure 9 - Interior Lights.....	16
Figure 10 – Typical 2-way Radio .....	17
Figure 11 – FSAM Radio Antennae .....	18
Figure 12 - Air Conditioning Unit .....	19
Figure 13 – Fuel Cell Operation [4].....	24
Figure 14 – Fuel Cell Chemical Process.....	25
Figure 15 – Breakdown of Hydrogen Production [12] .....	28
Figure 16 – Steam Methane Reformation .....	28
Figure 17 – Electrolysis .....	29
Figure 18 - Major Hydrogen Production Processes .....	29
Figure 19 – Greenhouse Gas Emissions Comparison.....	31
Figure 20 - Greenhouse Gas Emissions of Various Vehicles .....	32
Figure 21 - Decibel Comparison Scale .....	32
Figure 22 - Honda FCX Clarity .....	33
Figure 23 – Decibel Output Comparison.....	33
Figure 24 - Concentrated Solar Power.....	34
Figure 25 - Typical Solar Cell Arrangement .....	35
Figure 26 - Solar PV Cross Section .....	36
Figure 27 - Solar Power Conversion.....	36
Figure 28 - CSP v. PV.....	37
Figure 29 - Solar Panel Usage in the US .....	38
Figure 30 - The Sun's Radiation on Earth.....	39
Figure 31 - Breakdown of Human Carbon Emissions .....	39
Figure 32 - Simple Solar Battery Charger .....	40
Figure 33 - Effect of light angle on panel .....	41
Figure 34 - Solar Power on Ambulance.....	42
.Figure 35 - Life-Cycle Energy Consumption Report .....	44
Figure 36 - Right View .....	47
Figure 37 - Left View .....	48
Figure 38 - Front View .....	49
Figure 39 - Rear View.....	49

Figure 40 - Curbside Interior View.....	50
Figure 41 - Street Side Interior View.....	50
Figure 42 - Interior Ceiling Lights.....	51
Figure 43 - Air Turbine Break-down [31] .....	52
Figure 44 - The InVentus Ventomobile .....	53
Figure 45 - CMT-380 Microturbine.....	53
Figure 46 - PHEV Configuration.....	54
Figure 47 - Drivetrain Options.....	55
Figure 48 - Series PHEV.....	56
Figure 49 - Parallel PHEV .....	56
Figure 50 - Power-split PHEV .....	57
Figure 51 - Series v. Parallel Hybrids.....	57
Figure 52 - EPA Fuel Economy Comparisons.....	58
Figure 53 - Hybrid Modes of Operation .....	59
Figure 54 - Typical driving distribution of electric v. petrol .....	59
Figure 55 - Functional Diagram of Various Modes of Operation .....	60
Figure 56 - GM Next-Generation Hybrid System .....	60
Figure 57 - Lithium Ion Battery Components.....	61
Figure 58 – Intercalation Cycle.....	62
Figure 59 – Oxide Requirements .....	63
Figure 60 - Battery Weight v. Driving Range.....	68
Figure 61 – Specific Energies of Various Batteries.....	68
Figure 62 - Specific Energy and Energy Density .....	70
Figure 63 - Advantages of Li-ion Batteries .....	71
Figure 64 - Battery Weight v. Driving Range.....	72
Figure 65 - Disadvantages of Li-ion Batteries.....	73
Figure 66 – Graph of Li-ion battery Pricing compared to Energy Density, 1991-2005 .....	73
Figure 67 – Material cost of Li-ion battery cell.....	75
Figure 68 – Interaction of battery and fuel costs .....	76
Figure 69 – Cycle life Test Results at 20000 cycles.....	77

## List of Tables

Table 1 – Detail Power Consumption Break-Down .....	5
Table 2 - Converted Emergency Lighting Scheme.....	15
Table 3 – PEM v. DMFC Fuel Cells.....	26
Table 4 - Environmental Impact of Fuel Cells [6].....	31
Table 5 - Comparison of LEDs, Incandescent, and CFLs .....	45
Table 6 - Light Output Comparison.....	46
Table 7 - Comparison of Metal Oxide Cathodes .....	64
Table 8 - Physical Properties of Various Li/air & Li-ion Positive-Electrode Active Materials .....	69
Table 9 - CO2 emissions according to MPG .....	72
Table 10 – Summary of Manufacturing cost components .....	74
Table 11 - Material Costs for 100-Ah High Energy Cell and a 10-Ah High Power Cell.....	74
Table 12 – Current Cathode Material Prices.....	75

## **Chapter 1 EMS Power System Improvement**

### **1. Introduction**

In life threatening situations, power failure could ultimately mean the difference between life and death for a patient in vital condition. Improving the system that distributes power to necessary medical components within the ambulance will limit the chance of electrical failure. The objective here is to increase the amount of available power onboard an ambulance to improve the efficiency of patient care. Existing designs inadequately utilize energy on several different levels. Effective management of the power onboard an ambulance will benefit patients in potentially life threatening situations and provide an environmentally efficient alternative. By identifying how current ambulance power systems work, it is clear how they can be improved. Research conducted on the power consumption of all components within an ambulance gives an understanding of which components use the most power. These components include energy loads such as lifesaving medical equipment, sirens, interior/exterior lights, communication, or other standard vehicle devices.

In Chapter 2, data regarding power consumption and supply within the ambulance are presented to portray the importance of an improved system. The consumption of each individual component within the ambulance is calculated and compared to the supply of power through the alternator and batteries. Each category of power consuming devices is broken down and examined. With this information graphs are created in order to visually see the distribution of power throughout the ambulance. These graphs clearly show which aspects of the ambulance require the most power, and which have room for improvement. In Chapter 3, the most plausible and practical solutions to the problem of power consumption are discussed. Research into new energy technologies provided benefits and drawbacks for each

technology. The practicality, applicability, cost, efficiency, and necessity are all factors which are considered in choosing the most appropriate technologies. These solutions are explained to justify the possibility of integrating them into a current ambulance power system. In Chapter 4, a detailed description of the final conclusions and designs is provided. The data found is analyzed and applied to the specified solution. This provides a low-cost design for a significantly more energy efficient ambulance which can be implemented into existing ambulances around the world.



## **Chapter 2. Sufficient Power Supply in EMS Care**

### **2. Introduction**

Electrical power supply is a crucial element in the success and quality of EMS care. Nearly all components within ambulance rely on electricity to function. These components include all of the ambulances lights, communication systems, rescue equipment, and temperature control units. In some circumstances, a passenger receiving care may require the use of several medical devices, a variety of lighting instruments, and some form of temperature control running all at the same time. Therefore, by individually detailing each form of power consumption and obtaining its electrical requirement, we provide the necessary information to analyze the ambulances total power consumption. In order to further understand the power consumed within an ambulance a general breakdown of the primary components used in each of these categories can be seen in Figure 1.

The lighting category includes interior lights located in both the passenger bay as well as the driver's cabin, while the exterior lights include emergency lighting and standard vehicle operation lights [1]. Communication can be broken down into the exterior public siren, ambulance intercom system, and the two-way radio used to communicate with other ambulances and base. Temperature control is divided into heating, cooling, and ventilation for both the patient and driver's cabin. Finally, a variety of medical equipment is powered using either the patient bay AC outlets or exterior AC outlets. The breaking down of power consumers within an ambulance leads to a further detailed, numerical representation to visually see the distribution of power.

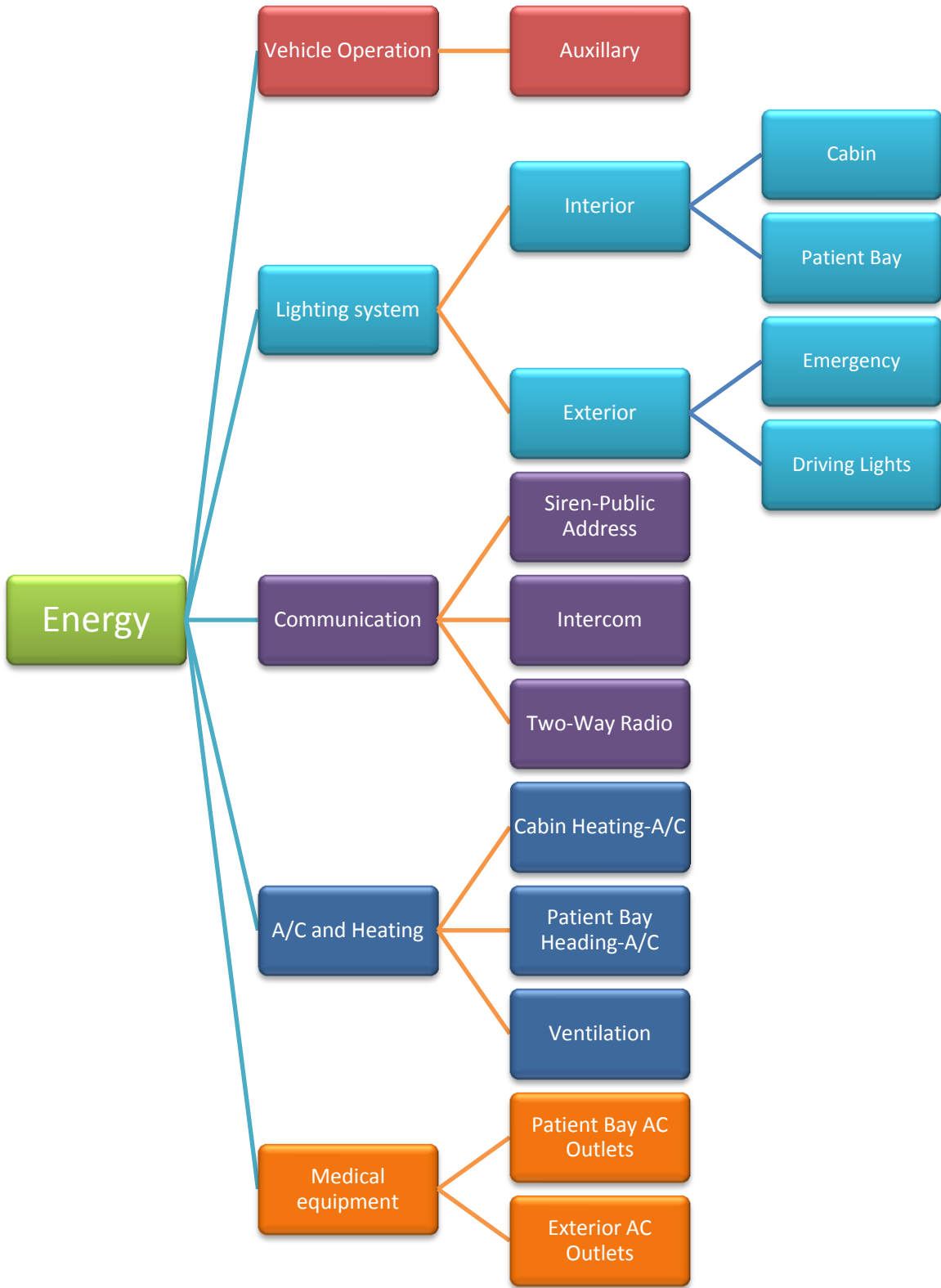

**Figure 1 – Power Consumption Break-Down**

## 2.1 Typical Ambulance Power Consumption

In an attempt to safely manage the power needed to supply all the necessary lifesaving rescue equipment, the total power consumption, in Watts, was compiled. In order to compile all the information for this chart, each device and light was individually analyzed. From owner's manuals and manufacturing fact sheets, the required operating voltage and amperage were determined. Then to analyze in terms wattage, the current and voltage were multiplied. The information necessary to compute total power consumption is now prepared in Table 1.

**Table 1 – Detail Power Consumption Break-Down**

<u>Ambulance Rescue Equipment</u>	<u>Manufacturer</u>	<u>Model</u>	<u>Required Operating Voltage</u>	<u>Current (Amperage)</u>	<u>Power Consumption (Watts)</u>	<u>Description</u>
Defibrillator	Physio Control	LifePak CR Plus	11.7	1.4	16.38	Battery Charger
Suction Unit	SSCOR	Quickdraw Series	12	0.7	8.4	Battery
Digital Oxygen Monitor	Amico	Z-TH9002-N	12	1	12	Power Supply
Nebulizer	Clinical Guard	HL-100	12	1	12	Power Supply
Pace Maker	EXPMT	Pacemaker Analyzer	9	0.1	0.9	Battery
Two Way Radio	RCA Communications Systems	BR250 Series	7.5	2	15	Power Supply
Air Conditioning Unit	Webasto	Diavia	12	13	156	Power Supply
Air Heating Unit	Webasto	Air Top Evo 3900/5500	24	2.3	55.2	Power Supply
Water Heater	Webasto	Thermo 230/300/350	24	2.7	64.8	Power Supply
Siren	Carson Sirens	SA-400 Classic	16	16	256	Power Supply
				Rescue Equipment Power Consumption:	596.68	Watts
Interior Lights	WHELEN		24	1	24	24
Driver's Dome Light	WHELEN		12	2.1	25.2	25.2
Instrument Panel Lights	WHELEN		12	2.1	25.2	25.2
Console Lights	WHELEN		24	0.7	16.8	16.8
Patient Dome Lights (x4)	WHELEN		12	2.1	25.2	100.8
Exterior Lights						
Fixed Red Light (x12)	DT MOTO		12	3	36	432
Fixed Amber Light	DT MOTO		12	3	36	36
Fixed Clear Light	DT MOTO		12	3	36	36
Flood Light (x2)			12	1.25	15	15
Loading Light			24	0.63	15.12	15.12
					Light Power Consumption (W)	726.12
					Total Ambulance Power Consumption (W)	1322.8

As seen in Table 1, several subtotals were analyzed. First the total power consumption of the necessary rescue equipment totaled 385.48 Watts. Then interior lights totaled 116.4 Watts, while exterior lights totaled 138.12 Watts. Temperature control power consumption totaled 211.2 Watts. A visual breakdown of these totals with respective percentages is seen below in Figure 2.

<b>Rescue Equipment</b>	<b>Air Conditioning</b>	<b>Interior Lights</b>	<b>Exterior Lights</b>
385.48 Watts	211.2 Watts	116.4 Watts	138.12 Watts

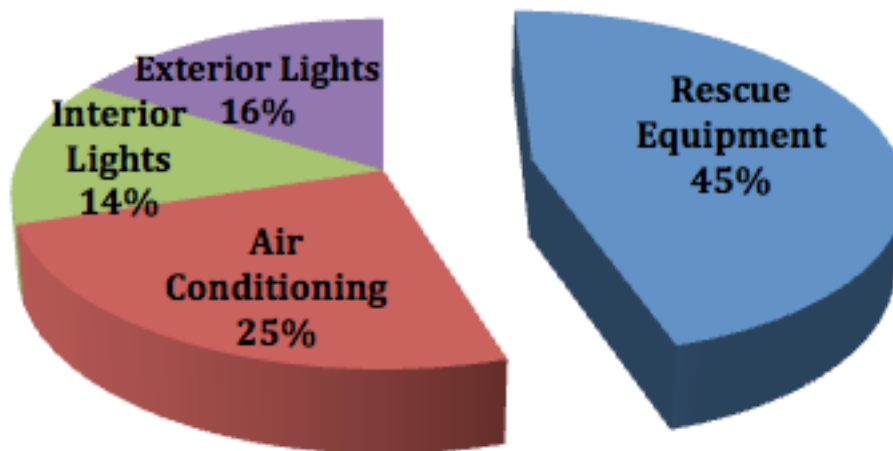

**Figure 2 – Power Consumption Pie Chart**

As displayed the rescue equipment requires the most power to run, but in more practical situations only a few of the rescue devices will be used at one time, greatly reducing the total electrical draw. However, when a rescue mission is underway it is entirely possible that all of the vehicles lights will be simultaneously running including interior patient cabin, emergency, and standard driving lights. Also, a large portion of the air condition section is likely to be running at all times, adding a considerable amount of continuous power consumption. While it is entirely unpredictable how much power will be needed for every

individual ambulance excursion, the maximum power needed to run all electrical components is a valuable computation. It allows us to recognize the power requirements when considering Federal ambulance design standards in the following sections and in Chapter 3, Concepts for Improvement.

## **2.2 Ambulance Design Criteria**

By definition an ambulance is a vehicle used for emergency medical care and patient transport. Understanding and following design standards published by State, Federal, or International agencies is an integral part of developing a new power system. In nearly all projects carried out by engineers, standards provide the guidelines from the initial stages of the project all the way until its completion. These standards define what is required in order to produce a safe, efficient, and properly maintained ambulance.

In this project, the specifications we are interested in identify the minimum requirements for new automotive Emergency Medical Services (EMS) ambulances (except military field ambulances) built on Original Equipment Manufacturer's Chassis (OEM). The original manufacturer of the ambulance must meet the required standards if they wish to sell their vehicles to state or federal organizations, like the “Star of Life” ambulances. A great power system can be designed, but if it doesn’t follow the specified guidelines it cannot be used in the field. On Sept. 25, 2012, the new National Fire Protection Agency (NFPA) 1917 Standard for Automotive Ambulances was released. It applies to new ambulances contracted for purchase on or after Jan. 1, 2013. The standard replaces the Federal KKK-A-1822 Ambulance Purchasing Guide (commonly referred to as the KKK) that’s anticipated to expire in October 2013 and add to the specifications of the AMD and older NFPA standard from 2009. The formulation of this new set of standards is shown in the graphic in Figure 3.

Throughout the rest of this report the standards that we are most concerned with will be summarized, with the applicable standards available for reference in the appendix.

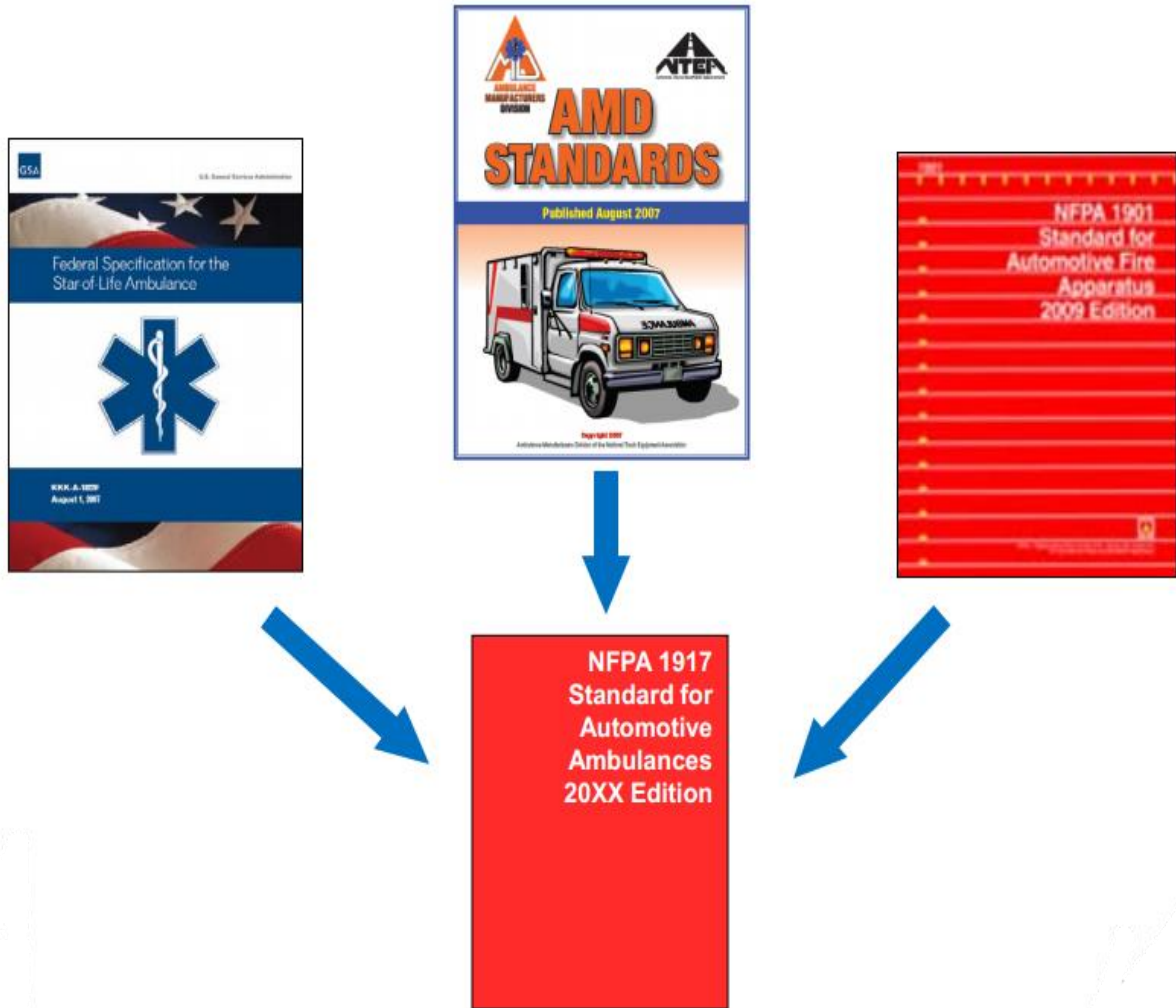

**Figure 3 – Formulation of NFPA 1917 Standard**

### **2.2.1 Electrical and Battery System Criteria**

An ambulance has several different configurations that generate, supply, and distribute electrical power to all of an ambulance's components. These systems include the battery, 12 Volt DC electrical system, and 125 Volt AC system. Each of these is utilized in different ways to effectively power the lights, temperature control, and rescue equipment. Additionally, they all have specific criteria based on the latest NFPA 1917 Standards. Understanding how these systems distribute power and the guidelines that govern them are important when considering the integration of a new power system. The remainder of this section will introduce the notable aspects of each system and clarify which electrical components within an ambulance rely on which system for operation.

First, the source of the all the power comes from the batteries. In ambulances there are generally two batteries with the option to install additional batteries if required. Batteries are located in a ventilated area, sealed off from occupant compartments, and are readily accessible for servicing and removal. When batteries are mounted in the engine compartment, they are provided with a heat shield as a safeguard against high under hood temperatures. All ambulances have an automatic charger/conditioner, which dynamically monitors the amount of charge within the battery and automatically charges and protects the battery from overcharging and overheating. The charger/conditioner is connected to both the 12 Volt DC system and 125 Volt AC system and is capable of supplying at least 10 Amperes of current while in operation [1].

There is also a separate circuit for charging all portable battery powered devices, such as, suction units, hand lights, portable radios, etc. This circuit prevents discharge of chassis batteries by only permitting the charging of portable devices when the vehicle is either

running or the optional battery conditioner is connected to maintain power. This separate circuit must have circuit breaker protection with a minimum 10-amp capacity.

Running off the batteries explained above is a 12 Volt DC electrical system. The 12 Volt DC system provides power to the auxiliary connectors (commonly referred to as “cigarette lighter” sockets) within the ambulances patient compartment [1]. These sockets are used very frequently to power a wide variety of rescue equipment that relies on a power source. Each socket is rated for 12-volt DC, 20-Ampere capacity, and is on a separately protected circuit. The 12 Volt DC electrical diagram is pictured below in Figure 4.

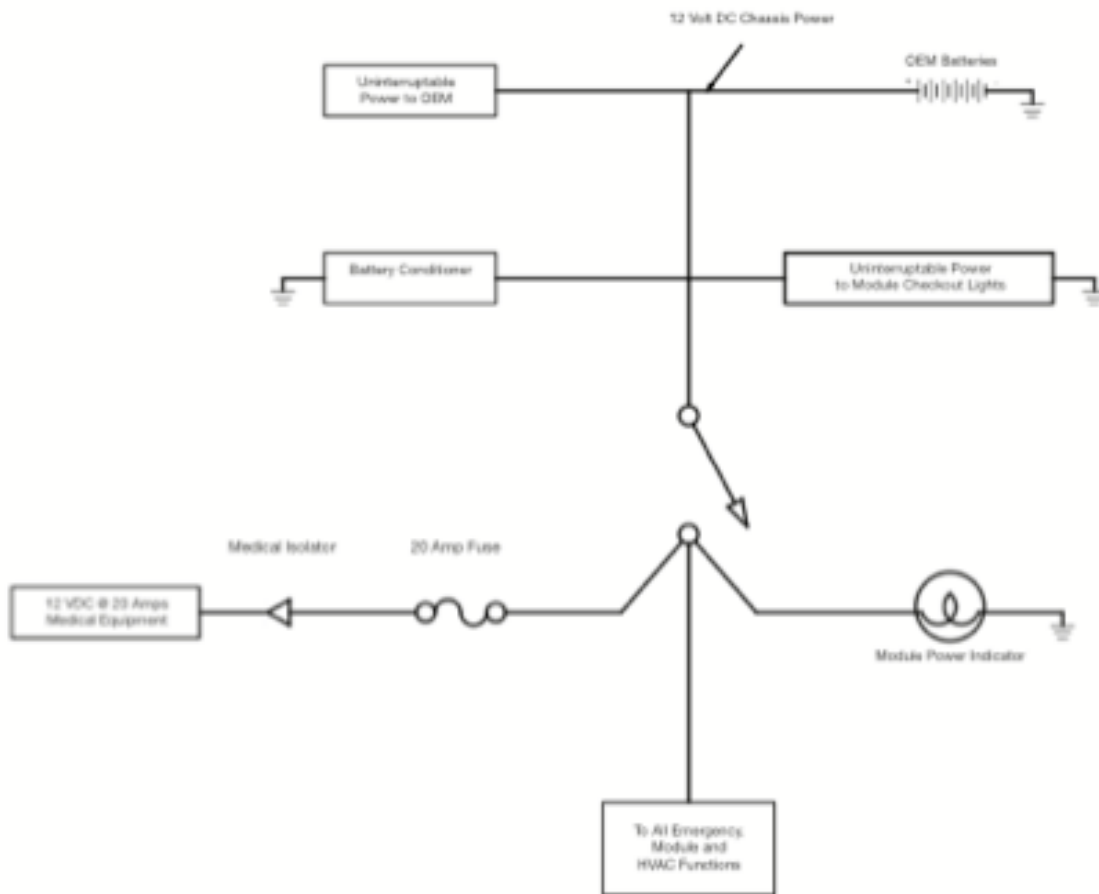

**Figure 4 - 12 Volt DC Electrical System**



The next electrical system contained within an ambulance is the 125 Volt AC system. This system is separate from the 12 Volt DC system and is responsible for powering maintenance devices, medical equipment, and battery chargers while the ambulance is stationary. The AC system also powers the ambulance's interior lighting, like the dome and cot lights. Like the DC system, the 125 Volt AC electrical systems have several inlets where electrical devices can be plugged in. One of these inlets is located on the exterior of the ambulance near the driver's side door and is considered the vehicle's external utility power source. Additionally, the patient compartment has two more receptacles to provide EMT's with accessible power supply for rescue equipment that doesn't conform to the other 12 Volt DC system. The 125 Volt AC electrical system is shown below in Figure 5.

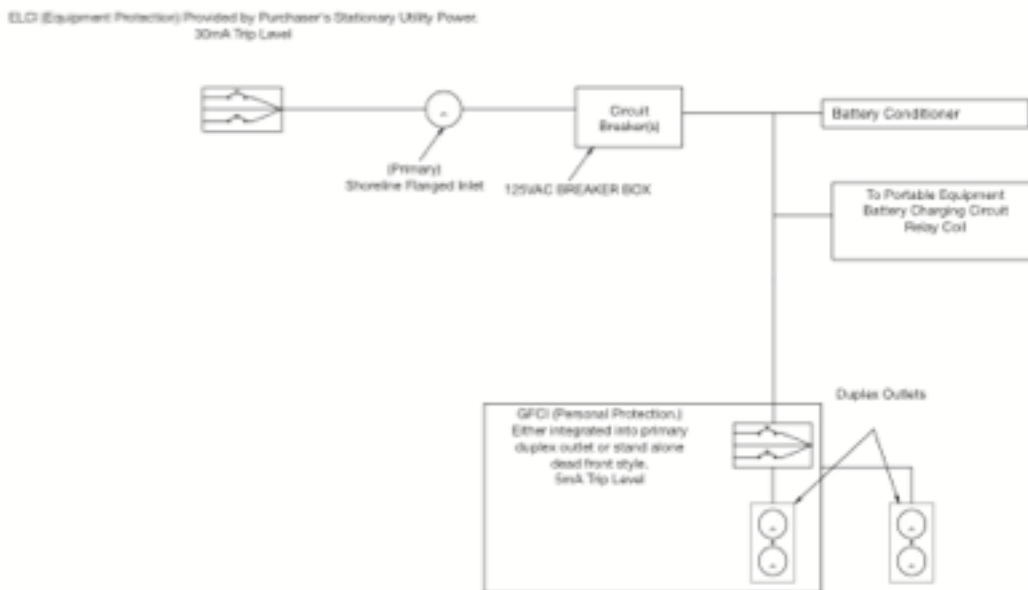

**Figure 5 - 125 Volt AC Electrical System**

### **2.2.2 Lighting - Interior and Exterior**

One of an ambulance's most noticeable features and major power consumer is its large array of lights. Whether it is the emergency lighting system, standard nighttime headlights, or interior patient cabin lights, lighting proves to be an integral part of this project's concentration. Therefore, the significant amount of lighting standards must be understood. The basic exterior ambulance lighting includes daytime running lights, the lower front marker lights, rear side marker lights, and flood and loading lights [1]. Flood and loading lights must be considered unobstructed by open doors and are located on the sides, while a patient loading light is located at the rear of the ambulance. Floodlight switches are located on the cab console and control each side independently. Loading lights are automatically activated when rear doors are opened.

The emergency lighting system provides the ambulance with 360° of clear visibility for optimum safety during its missions. The system's bright flashing lights displays highly detectable and attention getting signals to communicate "Clear the Right-of-Way" and "Hazard, Vehicle Stopped on Right-of-Way" in its primary and secondary modes. Electrically, the ambulance standard warning light system cannot use a continuous average electrical load exceeding 40 amperes at 14.2 volts [1]. The ambulance standard emergency warning light system contains twelve fixed red lights, one fixed clear light and one fixed amber light. All of the fixed lighting requires specific dimensional positioning about the body of the ambulance, which is detailed in Appendix A. As with the floodlights, doors or other equipment cannot obstruct the standard warning lights. All warning lights are mounted to project their highest intensity beams on the horizontal plane.

The lighting configuration of the on-campus ambulance can be seen in the model in Figure 6 and Figure 7, which accurately depict the location and color of the exterior emergency lights.



**Figure 6 - Rear Ambulance Lights**



**Figure 7 - Front Ambulance Lights**

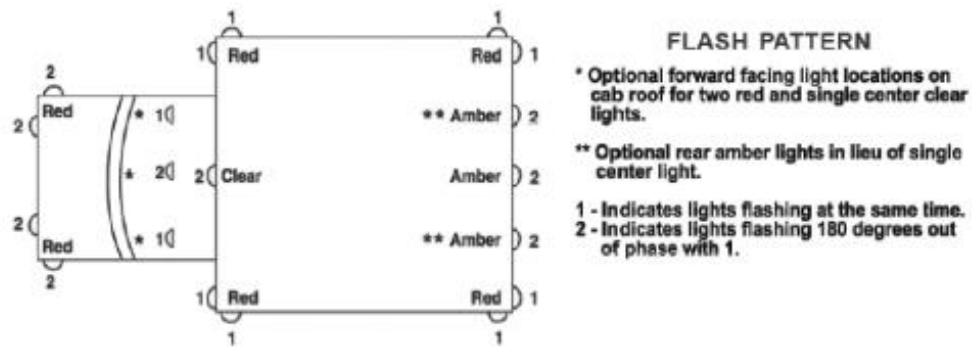

MINIMUM FLASH ENERGY, Cd-S PER FLASH, PER FIXTURE				
COLOR	RED		CLEAR	AMBER
LOCATION	GRILL & FENDERS	UPPER BODY CORNERS	FRONT CENTER	REAR CENTER*
DAY	160 Cd-S @ HV	240 Cd-S @ HV	900 Cd-S @ HV	600 Cd-S @ HV
	80 Cd-S @ ± 5° H Points	120 Cd-S @ ± 5° H Points	450 Cd-S @ ± 5° H Points	300 Cd-S @ ± 5° H Points
	12 Cd-S @ All 5° V - 45° H Points	32 Cd-S @ All 5° V - 45° H Points	96 Cd-S @ All 5° V - 45° H Points	72 Cd-S @ All 5° V - 45° H Points
NIGHT	10 - 30% of the above			

\* Single center rear or combined dual rear (Optional)

MODAL EMERGENCY LIGHTING SYSTEM					
MODE OF OPERATION	COLOR & LOCATION	RED	CLEAR	AMBER	RED
		Front and Rear Corners	Front Upper Center	Rear Center	Grille and Fender
PRIMARY "Clear the Right-of-Way"		ON	ON	ON	ON
SECONDARY "Hazard-Vehicle Stopped on Right-of-Way"		ON	OFF	ON	OFF

Figure 8 - Ambulance Flash Pattern [1]

Shown in Figure 8 are the flash patterns, minimum flash energy, and emergency

lighting system modes. In our project, the main focus is on the flash energy per fixture of the lights. In the chart pictured in Table 2, the units of flash energy are given in candela-seconds, but we are concerned with the minimum energy required rather than the candelas. Therefore, candela-seconds, essentially a measure of light energy released during a single flash, must be converted. The conversion is calculated as follows:

$$1 \text{ Candela} = 1/683 \text{ Watts} \Rightarrow 1 \text{ Watt} = 1 \text{ Joule/Second}$$

Therefore, 1 candela-second = 1/683 Joule

Based on this conversion factor the minimum flash energy per fixture can be presented in Joules for more relevance towards our project.

**Table 2 - Converted Emergency Lighting Scheme**

<b>Minimum Flash Energy, Joules Per Flash, Per Fixture</b>				
<b>Color</b>	<b>Red</b>		<b>Clear</b>	<b>Amber</b>
<b>Location</b>	Grill, Fenders	Upper Body Corners	Front Center	Rear Center
<b>Day</b>	0.234 J @HV	0.351 J @HV	1.318 @HV	0.878 @HV
	0.117 J @H Points	0.176 @H Points	0.659 @H Points	0.44 @H Points
	0.018 J @All V-H Points	0.047 @All V-H Points	0.141 @All V-H Points	0.105 @All V-H Points
<b>Night</b>	10-30% of the above			

Each emergency light will flash 75 to 125 times per minute and must produce a flash energy, measured from the H-V to all the extreme test point coordinates, as displayed in Table 2. At no point will the flash energy values drop to less than the minimum values when tested at 14.2 volt [1].

The interior ambulance lighting configuration is to be designed to minimize electrical loads. These interior lights include a driver's compartment dome light, instrument panel lights, master switch panel, and console lights. All of the interior lights should not obstruct the view of the ambulance's operator [1].



**Figure 9 - Interior Lights**

In the patient compartment the lights cannot be powered by the vehicles AC system. The floor must be illuminated with at least 15-foot candles (0.241 watts/sq. meter) intensity while the primary cot must have at least 35-foot candles (0.563 watts/sq. meter) of illumination on at least 90% of the cot's surface area. The interior dome lighting should automatically turn on when the patient compartment doors are open. The model in Figure 9

shows the basic interior lighting configuration. Also, the dome lighting cannot consume more than 25 amps in the bright setting and needs to have two separately protected and controlled circuits [1].

### **2.2.3 Communications**

The communication equipment in an ambulance must be installed by a licensed installer approved by the radio manufacturer. Any two-way radio systems must meet the applicable FCC rules and communication protocols set forth by the state and local EMS [1].

All ambulances have stern radio provisions. Ambulances must be provided with sufficient ventilated space for a two-way radio which includes convenience features, antenna openings, ground plane, and terminal wiring for 12 volt power and ground [1]. A typical two-way radio is shown in Figure 10.



**Figure 10 – Typical 2-way Radio**

Ambulances are required to have specific radio antenna cable access. The FSAM must provide each ambulance with these specifications. First, a ground plane and coaxial lead-in wire from the ventilated radio storage area/compartments to the centerline of the patient

compartment roof is required. Second, an antenna wiring port must be located in the patient's compartment directly under the coaxial leads.

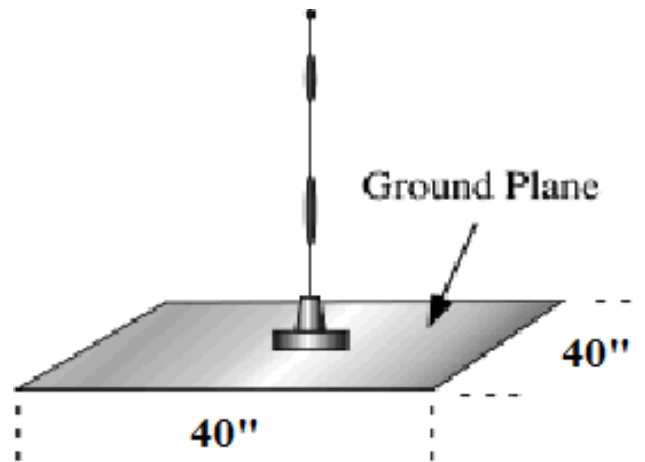

**Figure 11 – FSAM Radio Antennae**

The ground plane will be grounded properly to the chassis ground. The provided antenna cable will be visibly labeled with RG/58U or similar cable. This configuration can be seen in Figure 11. Approximately 18 inches of surplus wire shall be placed at the roof with approximately 36 inches in and or at the radio compartment [1].

All ambulances must follow the specifications regarding sirens and other public addressing systems. A combination of electronic siren(s) and public address system including radio interface capability must be provided. A siren switch must be on the driver's console easily accessible by the driver. Once the siren is turned on it must activate or change the siren tone when the horn button is pressed. The siren switch shall also be illuminated while on. A dual speaker system outside the vehicle bay is required. The speakers will be placed in the bumper or hood area. Speakers may not protrude beyond the face of the bumper or beyond the bumper guards. The siren will be capable of producing a continuous warning sound at a minimum level of 123 decibels, A-weighted, at 10 feet [1].



## 2.2.4 Air Conditioning

The requirements for Air Conditioning derive from the testing required by AMD. A typical vehicular air conditioner unit is shown in Figure 12. Specifically, the engine should start without the use of external power or starting fluids. The heater in each compartment should raise the thermocouple temperature to a minimum of 68 degrees Fahrenheit (24 degrees Celsius) within 30 minutes from 0 degrees Fahrenheit (-18 degrees Celsius) [1]. The air conditioner in each compartment should lower the thermocouple temperatures to a maximum of 78 degrees Fahrenheit (26 degrees Celsius) within 30 minutes from 95 degrees Fahrenheit (35 degrees Celsius) and 30% to 70% relative humidity [1].



**Figure 12 - Air Conditioning Unit**

### **2.2.5 Rescue Equipment**

All ambulances have a standard set of equipment which is required to be onboard. This list was established after the Committee on Trauma (COT), American College of Surgeons (ACS), and the American College of Emergency Physicians (ACEP) collaborated and created a joint document in the year 2000. This list was later revised by the National Association of EMS Physicians (NAEMSP) in 2005. This list of equipment can be broken down into the following categories: Basic Life Support (BLS) Ambulances, Advanced Life Support (ALS) Ambulances, and optional equipment. [1]

In the Basic Life Support (BLS) ambulance, the required equipment is as follows:

#### **A. Ventilation and Airway Equipment**

- a. Portable and fixed suction apparatus with a regulator, portable oxygen apparatus, portable and fixed oxygen supply equipment, oxygen administration equipment, bag-valve mask (manual resuscitator), Nasopharyngeal, Oropharyngeal, pulse oximeter, and saline drops.

#### **B. Monitoring and Defibrillation**

- a. All ambulances should be equipped with an automated external defibrillator (AED)

#### **C. Immobilization Devices**

- a. Cervical collars, head immobilization device, lower extremity traction devices, upper and lower extremity immobilization devices, and impervious backboards.

#### **D. Bandages**

- a. Commercially-packaged or sterile burn sheets, triangular bandages, various dressings, gauze rolls, occlusive dressing, adhesive tape, and arterial tourniquet.
- E. Communication
- a. Two-way communication device between EMS provider, dispatcher, and medical control.
- F. Obstetrical Kit
- a. Kit (towels, dressing, bulb suction, blanket, etc.), Thermal absorbent blanket and head cover, aluminum foil roll.
- G. Miscellaneous
- a. Sphygmonanometer, stethoscope, thermometer, heavy bandage scissors, cold packs, saline, flashlights, blankets, sheets, towels, disposable emesis bags, bedpan, urinal, wheeled cot, folding stretcher, stair chair, and lubricating jelly.
- H. Infection Control
- a. Eye protection, face protection, gloves, coveralls, shoe covers, waterless hand cleaner, disinfectant solution, standard sharps container, disposable trash bags, and respiratory protection.
- I. Injury Prevention Equipment
- a. All individuals in an ambulance need to be restrained, protective helmet, fire extinguisher, hazardous material reference guide, traffic signaling devices, and reflective safety wear for each crewmember.

In the Advanced Life Support (ALS) ambulance, the required equipment is as follows:

A. Airway and Ventilation Equipment

- a. Laryngoscope, Endotracheal Tubes, Meconium aspirator, syringes, Stylettes, Magill forceps, lubricating jelly, and end-tidal CO<sub>2</sub> detection capability.
- B. Vascular Access
- a. Crystalloid solutions, antiseptic solution, IV pole or roof hook, intravenous catheters, intraosseous needles, venous tourniquet, syringes of various sizes, needles of various sizes, intravenous administration sets, and intravenous arm boards.
- C. Cardiac
- a. Portable battery-operated monitor/defibrillator with tape write-out/recorder, pads, quick-look paddles or electrode, ECG leads, adult and pediatric chest attachment electrodes, transcutaneous cardiac pacemaker including pediatric pads and cables.
- D. Other Equipment
- a. Nebulizer, glucometer, and large bore needle for chest decompression.
- E. Medications
- a. Various medications, irrelevant to list here.

There is also a list of optional equipment, which can assist EMS providers to choose equipment that can be used to ensure quality pre-hospital care.

A. Optional Equipment

- a. Glucometer, elastic bandages, cell phone, infant oxygen mask, neonatal blood pressure cuff, pediatric immobilization devices, topical hemostatic agent, and applicable chemical antidote auto injectors.

These lists give an in-depth understanding of exactly what is required to be on the ambulance, and it can be noticed that there are not many devices that require a significant amount of power for general patient care.

## **Chapter 3. Concepts for Improvement**

### **3. Introduction**

Now that the electrical power systems within an ambulance are fully understood, there are steps which can be taken to increase the efficiency of these systems. Although most ambulances don't necessarily require more power than what the dual battery system provides, if the electrical load could be reduced then the power will be more effectively distributed throughout the ambulance. This will allow for the ability to add any extra medical equipment which was previously thought to consume too much power to be utilized onboard. More efficient ambulances would provide increasingly effective emergency transportation, while reducing the amount of environmental impact.

#### **3.1 Ideas for Improvement**

There are many possibilities which would provide a reduction in power consumption by the equipment within the ambulance. Some of these options are fuel cells, solar power, LED lighting, air turbines, and lithium ion batteries. Some trade-offs which must be made are between efficiency/cost and practicality/necessity. By comparing these opportunities to increase power availability while decreasing power consumption, it is easy to see which ones have the ability to be implemented into ambulances. The goal isn't necessarily to create a fully electric ambulance, because that would require significantly more power than is plausible. But if these systems could be implemented so that all electrical devices could be

run off renewable energy, major energy savings would allow for a smaller carbon footprint and less overall cost.

### 3.2.1 Fuel Cells

In the coming years fuel cell technology may provide an alternative source of power generation for an ambulance. A fuel cell is an electrochemical device that uses hydrogen and oxygen to produce electricity with water and heat being the only by products. Essentially a fuel cell consists of an anode and cathode with an electrolyte between them. The process in which electricity is created is a result of chemical reaction between the hydrogen and oxygen [3]. This process can be seen in Figure 13 below. At the anode, hydrogen reacts with a catalyst resulting in a negatively charged electron and a positively charged ion. A proton then passes through the electrolyte the electron simultaneously passes through a circuit, which creates a current. Then at the cathode, oxygen reacts with the positive ion and electron,

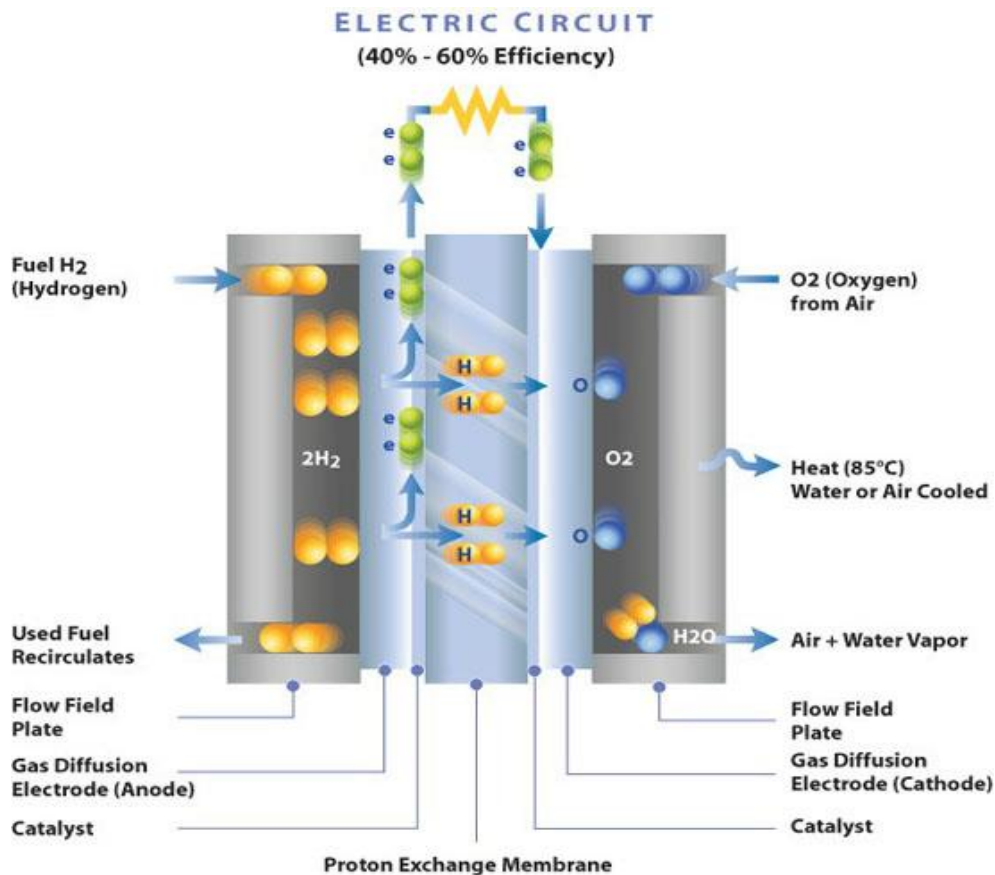

Figure 13 – Fuel Cell Operation [4]

creating water and heat. One cell creates only about 0.7 Volts, but for practical applications the cells are stacked in series to increase the output for a multitude of uses [5].

### Types of Fuel Cells

There are many different types of fuel cells currently available and in development. These different types vary primarily in the chemical reactions, operating temperatures, catalysts, and electrolytes. Based on these variations, each different type of fuel cell technology specialized in specific applications that can be implemented in an ambulance. The different types of principle fuel cells include alkaline fuel cell (AFC), proton exchange membrane fuel cell (PEM), direct methanol fuel cell (DMFC), molten carbonate fuel cell (MCFC), phosphoric acid fuel cell (PAFC), and solid oxide fuel cell (SOFC) [5]. The basic chemical process and operating temperatures of these fuel cell technologies are shown in Figure 14.

Figure 14.

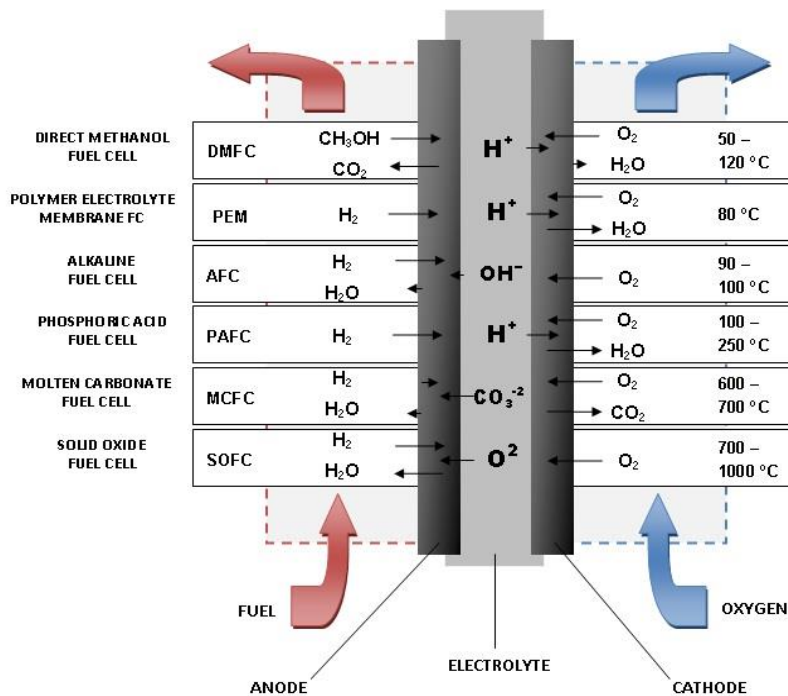

Figure 14 – Fuel Cell Chemical Process

For our interests, the proton exchange membrane fuel cells (PEM) and direct methanol fuel cells (DMFC) are most applicable to ambulances. A comparison of these can be seen in Table 3.

**Table 3 – PEM v. DMFC Fuel Cells**

	Electrolyte	Catalyst	Operating Temperature (°F)	Electrical Efficiency	Uses
<b>Proton Exchange Membrane Fuel Cell (PEM)</b>	Solid polymer membrane	Platinum	175-200	40-60%	Mid to large size vehicles
<b>Direct Methanol Fuel Cell (DMFC)</b>	Solid polymer membrane	Platinum	125-250	Up to 40%	Mid sized consumer electronics

PEM fuel cells are most commonly used for powering vehicles like busses, forklifts, and material handing vehicles because they can vary output quickly to meet shifts in power demand, and allow for quick startups. DMFCs are primarily used for much smaller applications like cell phones, laptops, and other consumer electronics. They are usually installed in RVs, boats, or camping cabins to power mid-sized consumer electronics [8].

Both PEM fuel cells and DMFCs have the ability to be used in an ambulance. As stated above, the PEM fuel cell have the ability to power mid to large size vehicles, meaning



they would be perfect to power an ambulances' primary chassis. Also, DMFCs can be used to power mid-sized consumer electronics like rescue equipment including the suction apparatus, defibrillator, two way radios, and temperature and blood pressure meters.

By allowing the PEM fuel cell to focus on powering the engine of the vehicle, and the DMFC to focus on the rescue equipment, a far safer environment is guaranteed. No longer will there be a possibility of the alternating ceasing power supply to the entire ambulance, including rescue equipment, by an idle or dead engine. Instead the two sources of fuel cell power work independently.

### *Hydrogen and Hydrogen Production*

Hydrogen is the essential fuel source for use in fuel cells. In order for fuel cell technology to succeed, hydrogen must be taken from the environment, put into a usable form, and be made available to those using it as a fuel source. Hydrogen is the most plentiful element on Earth, but it doesn't exist in elemental form so it must be separated from other compounds like water, plants, coal, and natural gas. Hydrogen has the highest energy per unit volume of all current fuels, despite being the lightest element [8]. Its energy density is 52,000 BTUs per pound, while gasoline has an energy density of only about 15,000 BTUs per pound [8].

A major advantage of hydrogen is that it can be produced in a large variety of ways. First, a natural resource must be obtained that contains hydrogen. Many resources contain hydrogen so it is often readily available in water, plants (like corn), coal, and natural gas [10]. Then, using a variety of technologies that produce power, hydrogen is extracted from these resources. These technologies include fossil fuel consumption, nuclear power, and renewable technologies, broken down in **Error! Reference source not found..**

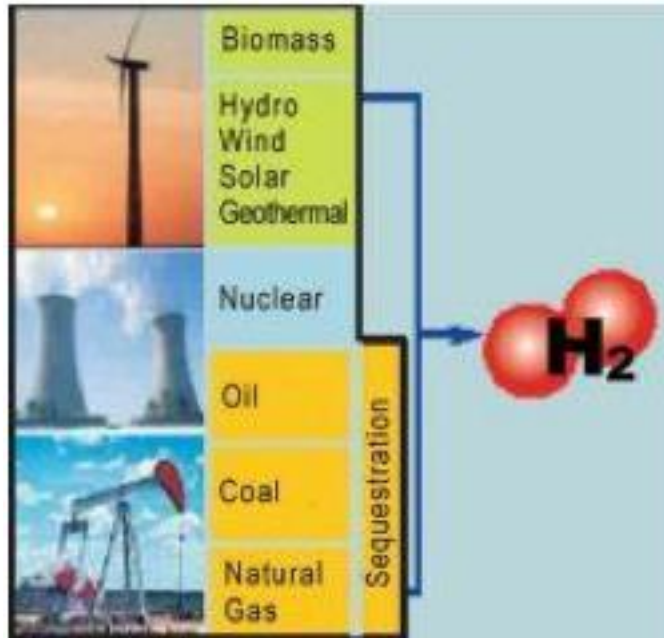

**Figure 15 – Breakdown of Hydrogen Production [12]**

In the United States, about 95% of hydrogen is produced from natural gas, while the figure is only about 48% for the rest of the world [11]. Ideally biogas will be utilized to produce hydrogen in the future. The process in -which hydrogen is produced from natural gas is called steam methane reformation. The chemical process is depicted below in **Error!** Reference source not found..

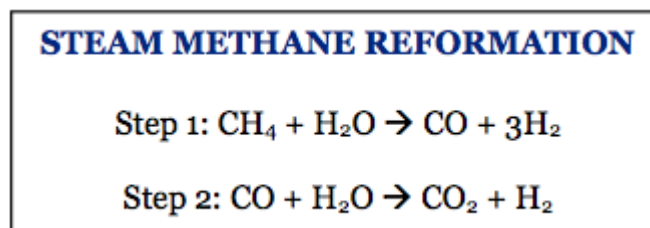

**Figure 16 – Steam Methane Reformation**

Hydrogen can also be produced directly from water and electricity by electrolysis. The chemical process is depicted in Figure 17.

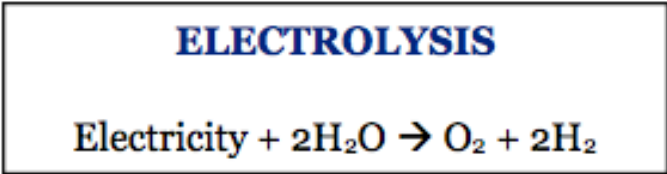

**Figure 17 – Electrolysis**

Many other processes of hydrogen extraction also exist. Many of these technologies are underdeveloped, too expensive, or not efficient enough for current widespread use. Figure 18 outlines the thermo, electrochemical, and biological methods of hydrogen production [11].

Primary Method	Process	Feedstock	Energy	Emissions
Thermal	Steam Reformation	Natural Gas	High temperature steam	Some emissions. Carbon sequestration can mitigate their effect.
	Thermochemical Water Splitting	Water	High temperature heat from advanced gas-cooled nuclear reactors	No emissions
	Gasification	Coal, Biomass	Steam and oxygen at high temperature and pressure	Some emissions. Carbon sequestration can mitigate their effect.
	Pyrolysis	Biomass	Moderately high temperature steam	Some emissions. Carbon sequestration can mitigate their effect.
Electrochemical	Electrolysis	Water	Electricity from wind, solar, hydro and nuclear	No emissions
	Electrolysis	Water	Electricity from coal or natural gas	Some emissions from electricity production.
	Photoelectrochemical	Water	Direct sunlight	No emissions
Biological	Photobiological	Water and algae strains	Direct sunlight	No emissions
	Anaerobic Digestion	Biomass	High temperature heat	Some emissions
	Fermentative Microorganisms	Biomass	High temperature heat	Some emissions

**Figure 18 - Major Hydrogen Production Processes**

### *Use of Fuel Cells in Vehicles*

A fuel cell vehicle (FCV) is a vehicle that uses a fuel cell for power generation. FCVs often combine with an electric battery to provide power for the startup, but can use the fuel cell to recharge the battery. These vehicles are called fuel cell electric vehicles (FCEV). Most automobile manufacturing companies announced that they will have commercially available FCEVs by the year 2015 [6].

In many ways fuel cell vehicles outperform internal combustion and fully electric vehicles. In terms of performance, a FCEV operate at as high as 80 miles per gallon, drive more than 300 miles on one tank, and perform to the same level of other vehicles in all conditions [7]. Also since fuel cells emit nothing but water and heat, there is a huge reduction in pollution, greenhouse gasses, and energy dependence on imported oil. Additionally, studies by the Department of Energy and MIT have concluded that at a commercial level fuel cell vehicles will be cheaper than gasoline and electric powered vehicles [2]. Finally, hydrogen fuel tanks and stacked fuel cells take up much less space than internal combustion units and even lithium ion batteries.

A current restraint on the fuel cell industry is the scarcity of hydrogen stores and hydrogen fuel stations. Around the world there are only about 100 stations, 58 of them in the United States as of December 2012 [12]. Despite the lack of fueling station, the hydrogen fueling process is very simple and takes only a couple minutes, much like gasoline.

### *Benefits of Fuel Cells*

Fuel cell technology shows great promise as a future energy source because of the many benefits it provides. One of the most important aspects when considering all types of energy production is the effect on the environment. For this reason, fuel cells have a major

advantage over almost all other energy sources because to give off low to zero emissions. Since the only bi-product of a fuel cell is water and heat, the fuel cell itself emits no pollutant, while the production of hydrogen is the only form of pollution. Table 4 below shows the most common types of pollutants emitted by energy sources within the United States.

**Table 4 - Environmental Impact of Fuel Cells [6]**



	Efficiency % LHV	NO <sub>x</sub> (lb/MWh)	SO <sub>x</sub> (lb/MWh)	PM-10 (lb/MWh)	CO <sub>2</sub> (lb/MWh)
Average US Grid	33%	3.43	7.9	0.19	1,408
Average US Fossil Fuel Plant	36%	5.06	11.6	0.27	2,031
DFC Fuel Cell on Nat Gas 47% efficiency	47%	0.01	0.0001	0.00002	940
DFC Fuel Cell on Nat Gas CHP 80% efficiency	80%	0.006	0.00006	0.00001	550
DFC Fuel Cell on Biogas CHP 80% efficiency	80%	0.006	0.00006	0.00001	0

Table 4 clearly shows that compared to fossil fuels, fuel cells generate much less environmentally dangerous compounds [3]. In addition, this chart shows information on fuel cells depending on how the hydrogen was extracted, and all are still far safer for the environment than both fossil fuels and the average for the US grid. Figure 19 further quantifies the comparison of greenhouse gas emissions of gasoline vehicles, electric vehicles, and fuel cell vehicles.

Another benefit of fuel cells that highly pertain to their use in ambulances is their high quality power reliability. Power produced from a fuel cell does not have the same voltage surges and sags that are present in the current electrical grid. For example, fuel cells have a conditioner that that ensure high quality power where batteries can lose voltage and eventually die out over long periods of use [11]. Also, since hydrogen is the source of fuel for a fuel cell and hydrogen is the most abundant element in the universe, there is a high level

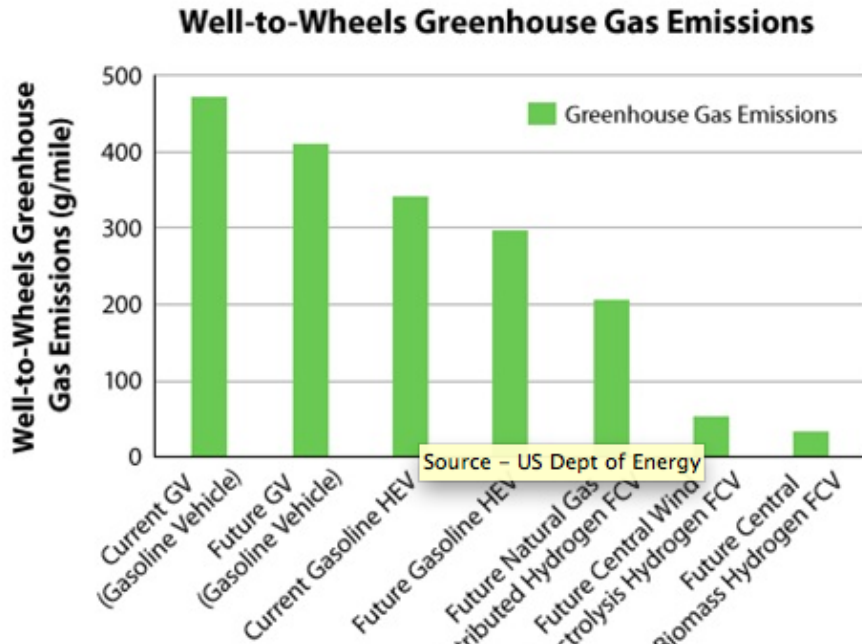

**Figure 20 - Greenhouse Gas Emissions of Various Vehicles**

of energy security. In order to develop an ambulance power system that has no chance of failure of the lifesaving equipment, fuel cells offer a reliable alternative.

Since fuel cells have no moving parts and there is no combustion the audible level of operation is very low [12]. Figure 21 shows the noise output of an average fuel cell system in

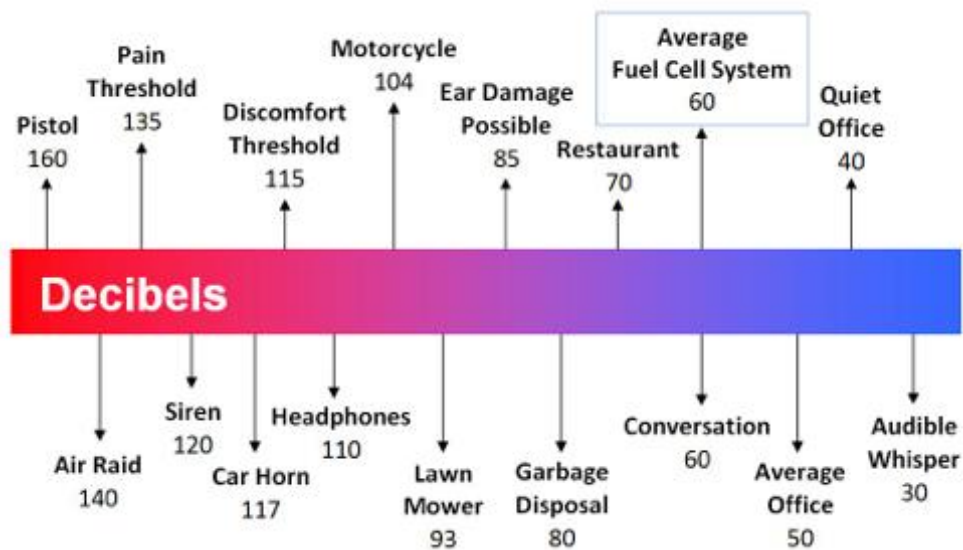
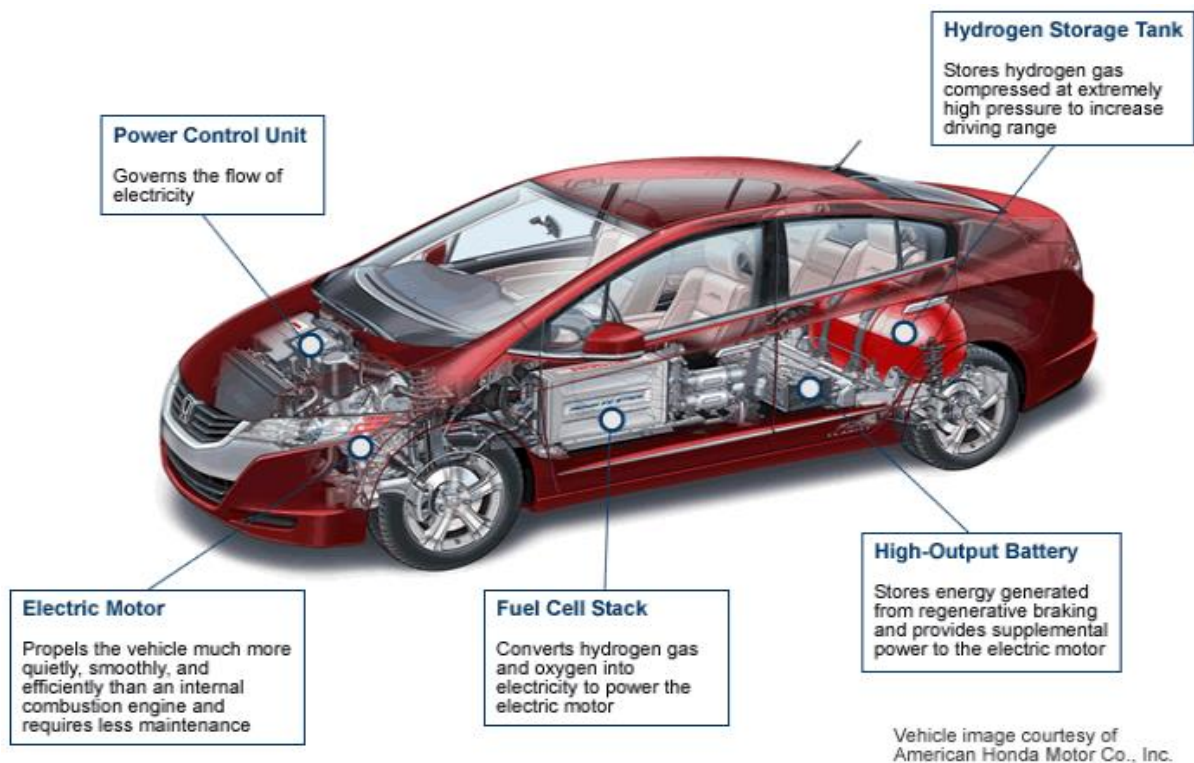

**Figure 21 - Decibel Comparison Scale**



terms of decibels compared to other recognizable noises.

Finally, the physical components of a fuel cell offer advantages like durability, are small in size, operate quietly, are lightweight, and last for long periods of use. For example, fuel cell technology can be utilized in many circumstances where they must be portable and rugged, like attached to a backpack of military personnel. Depending on the amount of power that needs to be outputted, fuel cells simply need to be stacked upon each other to create a series of cells. In comparison the conventional batteries, a fuel cell operates 10 times longer are much lighter while also needing no recharge accessories as long as fuel is present. A working hydrogen powered car developed by Honda, called the FCX Clarity [24]. A diagram depicting the layout and configuration of the hydrogen system is shown in Figure 22.



**Figure 22 - Honda FCX Clarity**

### 3.2.2 Solar Panels

Solar power is the conversion of sunlight into electricity. There are two methods of completing this process. The first, Concentrated Solar Power (CSP) uses lenses and/or mirrors in conjunction with a tracking system to direct and magnify sunlight onto CSP panels or heat sink as shown in Figure 24 [15] . The CSP can convert the solar power to electricity, while a heat sink would be used in conjunction with water and turbines to produce steam electricity. This method can be scrapped as it is completely unpractical in a vehicular application.



**Figure 24 - Concentrated Solar Power**

The second method is direct sunlight to Photovoltaic (PV). Photovoltaic panels work by absorbing solar radiation in solar cells, within a solar module, within a solar panel, which can be within a solar array comprised of several solar panels as shown in Figure 25 [15].



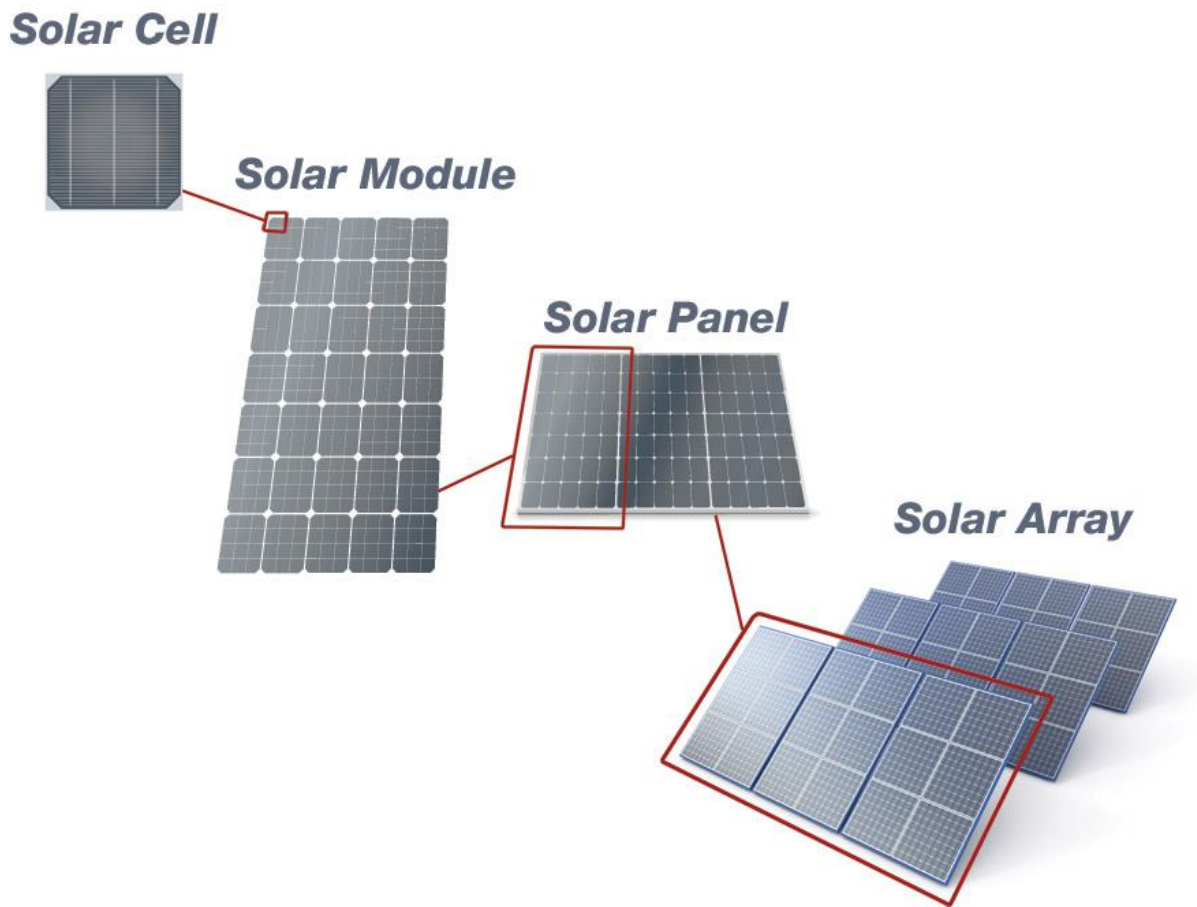

**Figure 25 - Typical Solar Cell Arrangement**

The solar cells contain a photovoltaic material, or material that generates voltage when radiant energy falls on the boundary between dissimilar substances (as two different semiconductors). This configuration can be seen in Figure 26. There are several different photovoltaic materials. The most commercially used and available are monocrystalline silicone, polycrystalline silicone, amorphous silicon, and hybrid [15].

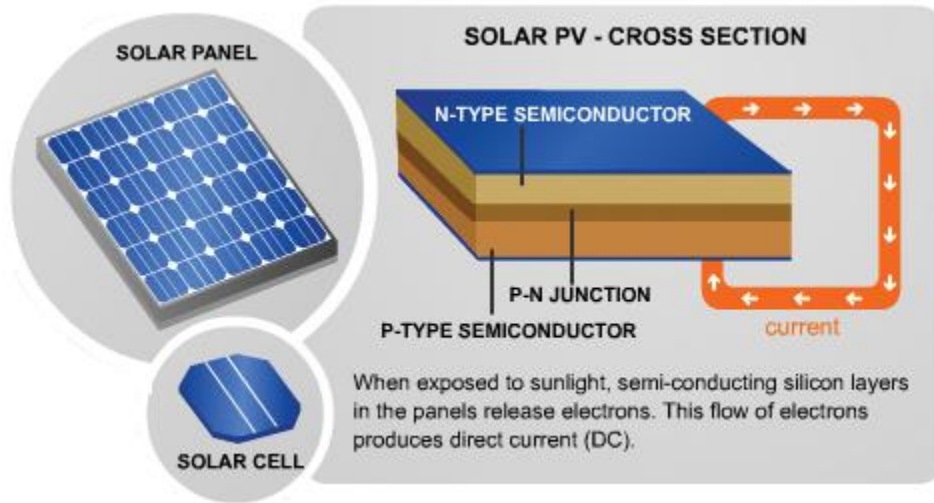

**Figure 26 - Solar PV Cross Section**

Once the PV cell creates an electrical charge a system of batteries are charged. Power can then be derived from the batteries either directly as DC current or through an AC converter in alternating current as shown in Figure 27 [15].

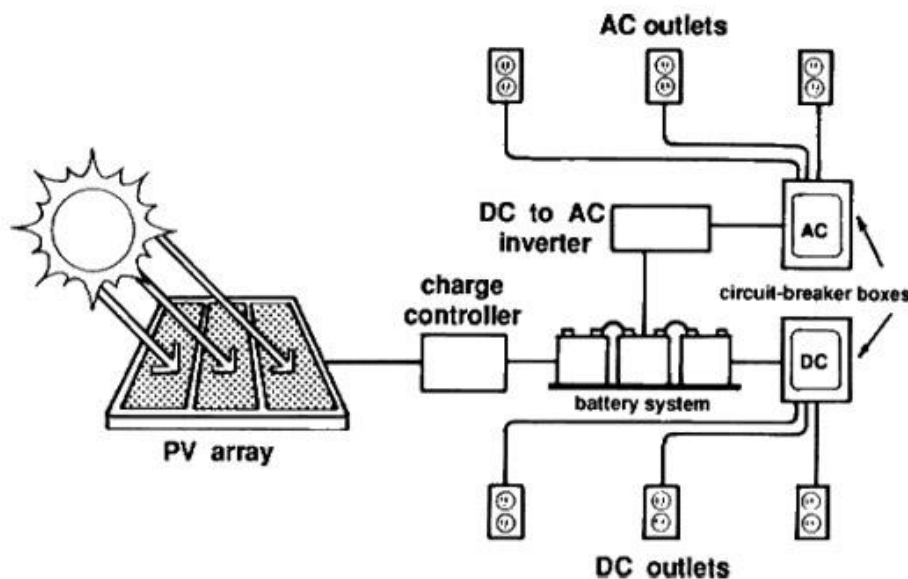

**Figure 27 - Solar Power Conversion**

The difference of concentrated solar panels and photovoltaic panels is that CSPs are used to generate heat, which can be used to boil water to create steam much like coal power

plants, whereas PVs convert the energy directly to electricity. These differences are summarized in Figure 28.

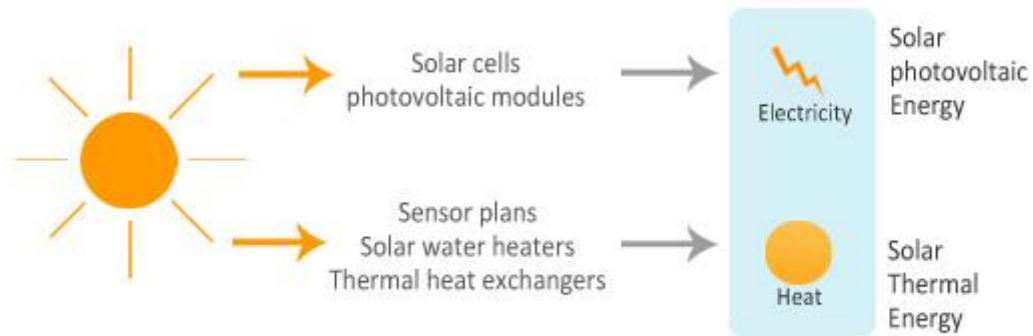

**Figure 28 - CSP v. PV**

Although solar power is a relatively old technology, recent breakthroughs have made it extremely attractive in the energy market. Solar power has become very popular and solar panels have become a relatively low cost commodity. The use of solar power has been exponentially increasing over the past 10 years, as can be seen in Figure 29 below.

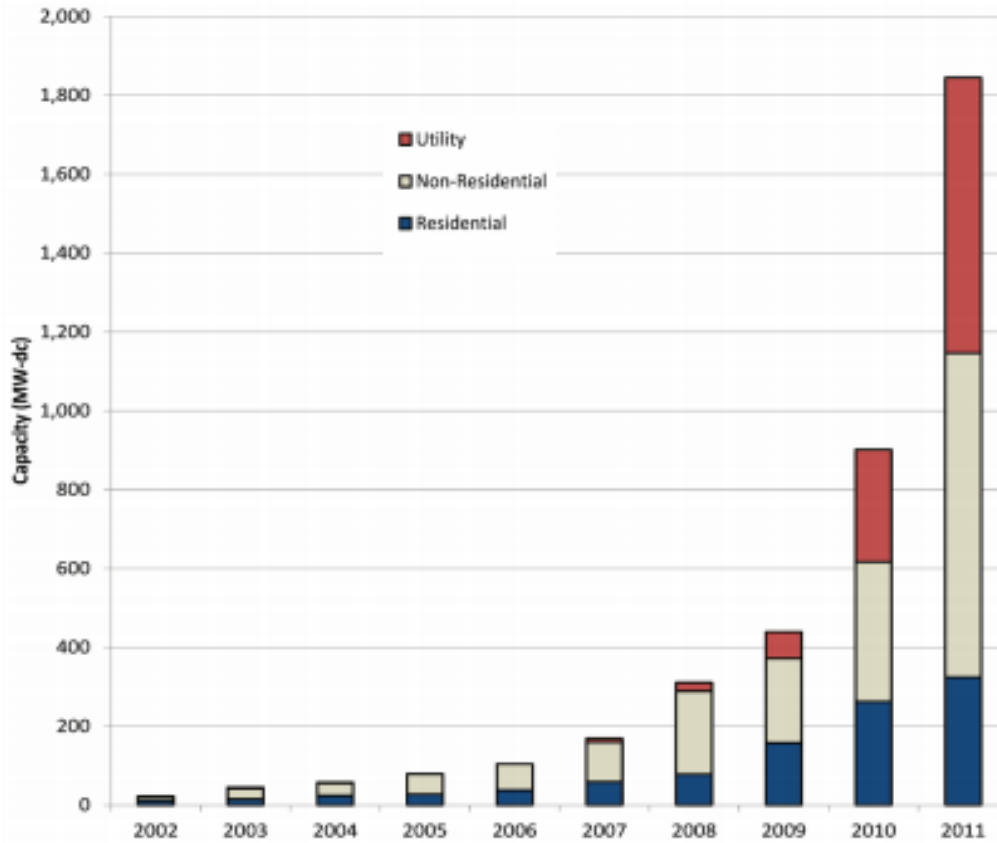

**Figure 29 - Solar Panel Usage in the US**

The graph shows how much solar power is being incorporated into the United States. The ever increasing rate of technology has allowed for exponential growth in the solar energy market. A vision into the future can only see this graph climbing higher into a more self-sustained and energy efficient lifestyle utilizing nature to meet our ever increasing demands as a population.

Solar power offers many benefits. It is the most abundant renewable resource on the planet, and the entire human population could derive all its power from one one-hundredth of one percent (0.01%) of the suns energy that reaches the earth [19]. If all of this energy could be utilized, electricity would be overly abundant throughout the world.

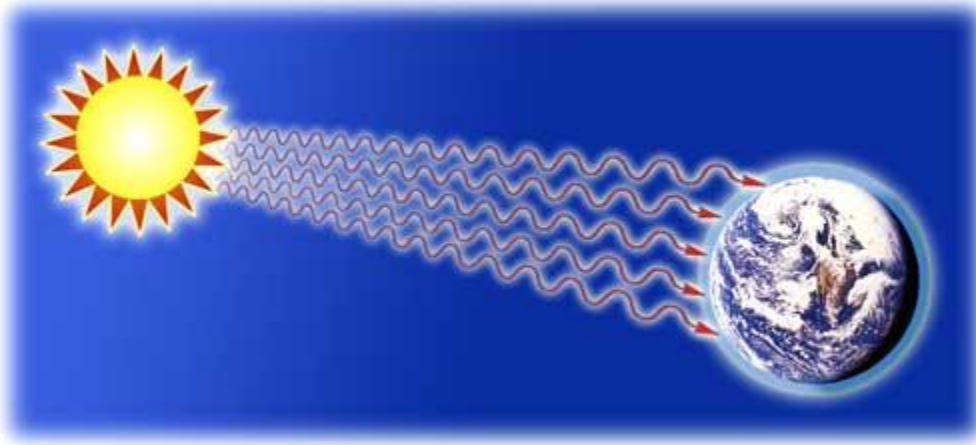

**Figure 30 - The Sun's Radiation on Earth**

Solar power is completely clean which means it will not pollute the earth in any way. This is a huge benefit because burning fossil fuels is the largest cause of pollution, and this

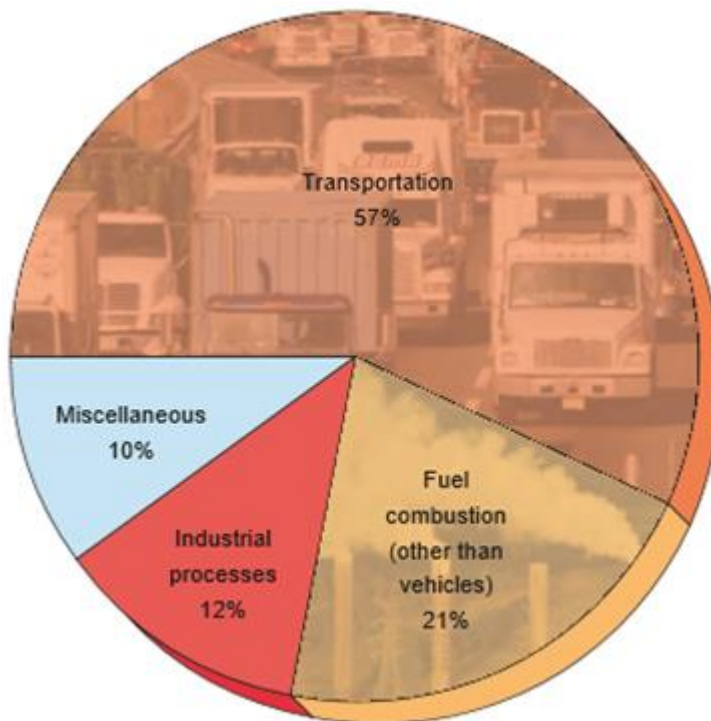

**Figure 31 - Breakdown of Human Carbon Emissions**

pollution is broken down into transportation, fuel combustions, industrial processes, and miscellaneous in Figure 31. An additional benefit is the size and ease of solar panels. Unlike other complex chemical conversions, solar panels provide a relatively high amount of power for a small volume (not area). The electricity solar panels produced can go directly to the battery for charging, making a system very simple to setup. This simplicity can be seen in Figure 32 below, where a simple circuit was created to charge batteries with a solar panel [16].

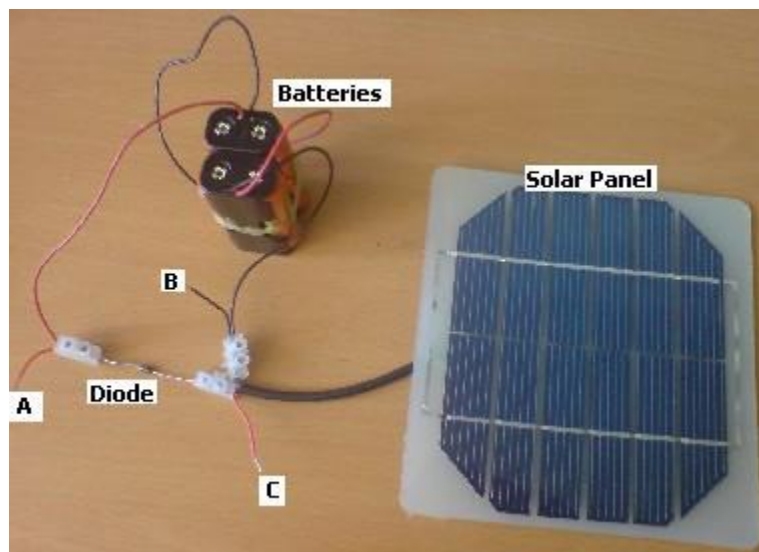

**Figure 32 - Simple Solar Battery Charger**

Though solar power offers many distinct advantages over other commercially available forms of energy there are also several disadvantages. Although the cost of solar panels and other required equipment has dropped drastically over the past decade, it is still much more expensive than fossil fuels (up front). Solar power requires a large area which is another disadvantage. Small spaces will only provide small amounts of energy. Another possible disadvantage is location. Solar power is much more effective in certain areas, and

much less effective in others. The distance from the equator plays a large role in determining this. When the sunlight hits a panel perpendicularly, less energy is absorbed than when it hits the panel at an angle, as demonstrated in Figure 33 [17].

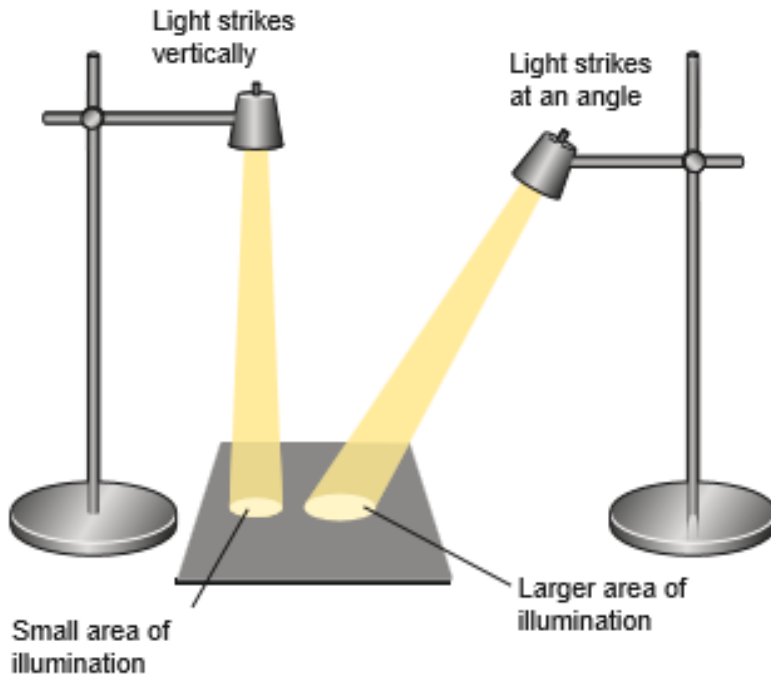

**Figure 33 - Effect of light angle on panel**

The most notable disadvantages found with solar power is cloudy and dark weather [15]. Without the sun solar power cannot function. This means all of the expensive solar equipment is useless for a minimum of half the day. The use of solar power in an ambulance setting is very practical. In fact this idea is being implemented today as shown in Figure 34 [21]. The ambulance offers many distinct opportunities that line up well with solar power. Ambulances are much more commonly run during the day than at night as people are often sleeping. Ambulances also run directly off DC batteries making the setup easy and effective. The roof of an ambulance is large and flat, a perfect environment for solar panels. Overall



solar panels can aid in the electrical system of an ambulance but, due to the many draw backs of solar power, could not be the sole source for the vehicles power.



**Figure 34 - Solar Power on Ambulance**



### **3.2.3 LED Lighting**

As previously discussed, the vast number of lights onboard an ambulance attribute to the majority of power consumed by the ambulance during normal operation. The emergence of LED technology has revolutionized the lighting industry due to its extreme durability, longevity, low operating temperature, and low power consumption. The only major drawback is the cost, which isn't significantly more than standard halogen lighting, and which will also pay for itself over time in energy savings. Many cities and counties have already converted their emergency vehicle lighting systems to LEDs because of its proven success in reducing energy consumption and minimal maintenance. For example, the city of Edwardsville, Illinois had allocated the appropriate funds to convert all emergency vehicle lighting systems to LED units. The fire chief had expressed concerns about ambulances experiencing one to two alternator failures per year, due to the tremendous amount of power drawn from the alternators while all exterior emergency lights and interior patient compartment lights are on. Combined with the heat output of the diesel engine and long periods of idling time, the alternators tended to burn out under the heavy electrical loads [25]. After converting to all LED lighting, the electrical draw was drastically reduced and less stress was placed on the alternators, reducing potential repair costs.

Over the past decade the emergence of LED lighting has brought a drastic reduction in electricity costs, due to its extreme efficiency. As shown in .Figure 35, today’s LED lamps clearly use the most energy in the manufacturing process, but the life-cycle energy consumption is about the same as CFLs and only about 25% of incandescence lamps. The Department of Energy predicts that ever advancing technology will again halve the life-cycle consumption of LEDs by the year 2015 [26].

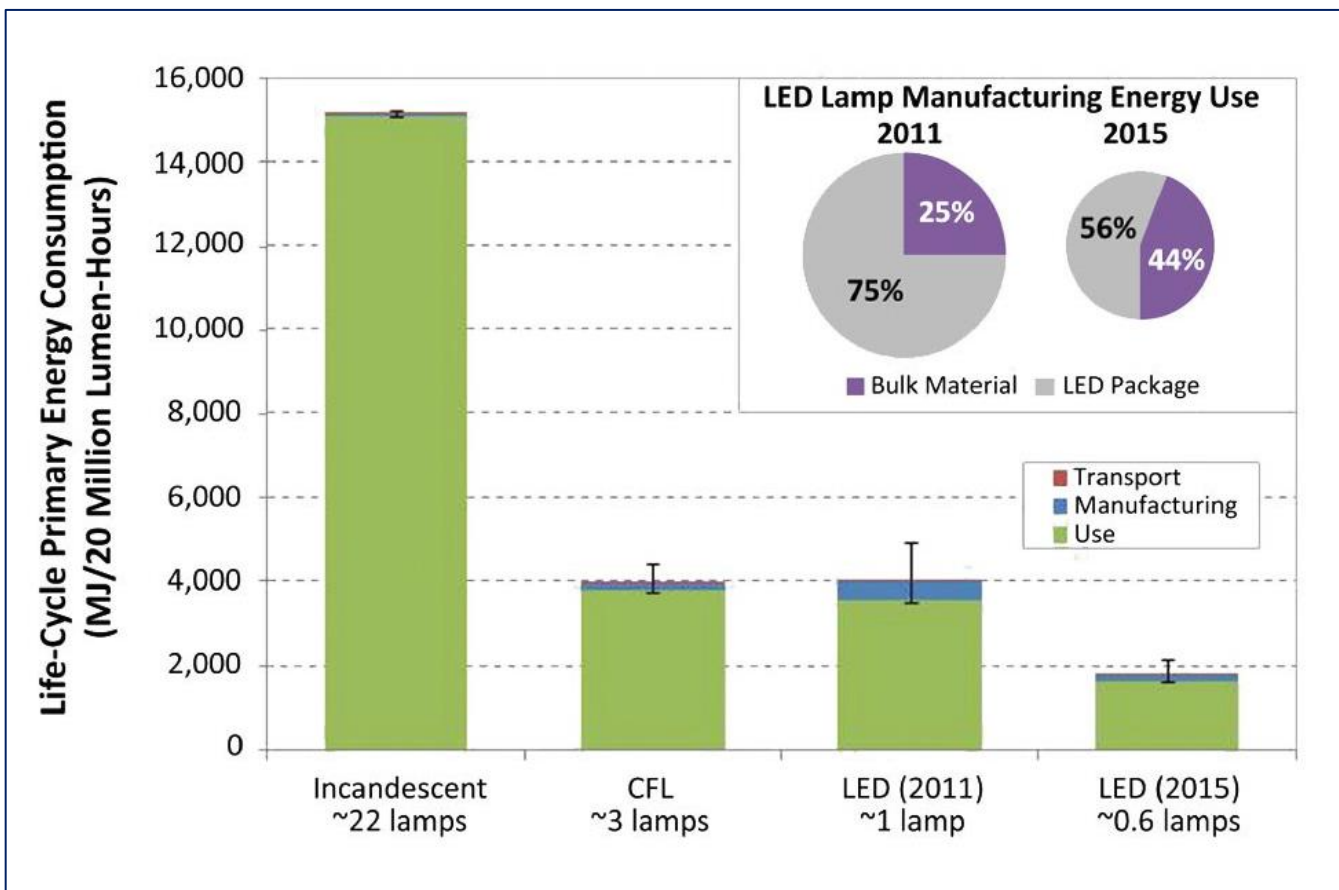

**.Figure 35 - Life-Cycle Energy Consumption Report**

The implications of this prediction are monumental, and it invokes an image of a future where energy is abundant and can be utilized to create new, and improve old, technologies. For example, ambulances which require little power to run all of the required lights can focus their energy on patient care and survival. This will allow new technologies

to be implemented into the ambulance while ensuring plenty of power for the rest of the life-saving equipment.

A summary of the some of the most important advantages of LEDs are shown in Table 5. Here it can be shown that LEDs effectively beat all competition in just about every possible category.

**Table 5 - Comparison of LEDs, Incandescent, and CFLs**

	<b>LEDs</b>	<b>Incandescent</b>	<b>CFLs</b>
<b>Life Span (average)</b>	50,000 hours	1,200 hours	8,000 hours
<b>Watts</b>	6-8 Watts	60 Watts	13-15 Watts
<b>KWh/yr</b>	329 KWh/yr	3285 KW/hr/yr	767 KWh/yr
<b>Annual Operating Cost</b>	\$32.85/year	\$328.59/year	\$76.65/yr
<b>Contains Mercury</b>	No	No	Yes
<b>RoHS Compliant</b>	Yes	Yes	No
<b>Carbon Dioxide Emissions</b>	451 pounds/yr	4500 pounds/yr	1051 pounds/yr
<b>Sensitivity to low temperatures</b>	None	Some	Yes
<b>Sensitivity to humidity</b>	No	Some	Yes
<b>on/off cycling</b>	No Effect	Some	Yes
<b>Turns on Instantly</b>	Yes	Yes	No
<b>Durability</b>	Very Durable	Delicate Glass/Filament	Delicate Glass
<b>Heat Emitted</b>	3.4 btu/hr	85 btu/hr	30 btu/hr
<b>Failure Modes</b>	Not Typical	Some	Yes - may catch fire

When compact fluorescent lights (CFL’s) first hit the market, they were praised as being the new “green” option for lighting. This was because they lasted about six times longer than incandescent bulbs with four times less power consumption. The only real disadvantages of CFL’s are that they contain a small amount of mercury, which can be very harmful if not

properly handled and disposed of. This also rejected the bulbs of their Restriction of Hazardous Substances Directive (or RoHS) compliancy, due to the toxic nature of the bulbs.

There are many other advantages of LEDs, particularly in the automotive industry. One advantage is their insensitivity to vibrations, because they have no fragile filament like incandescent bulbs [25]. When incandescent bulbs are used thicker filaments are required in order to withstand typical vibrations, which in turn establish their operating voltage and current. They also last the life of the vehicle, which is convenient because they never need to be replaced. A different and unique advantage is that can be baked into moisture proof casings, providing creative potential for weatherproof exterior lights. Particularly for brake lights, the instantaneous power-up advantage of LEDs causes light output to rise to full intensity about 250 milliseconds faster than incandescent bulbs. This provides increased time for other motorists to react to the lights. Since they are extremely compact, LEDs provide flexible packaging designs and unique arrays of lights which improve overall appearance [27]. Other advantages include the ability to have many different colors, low electromagnetic radiation, wide operating temperature range, and of course more lumens per watt than other bulbs [27]. A comparison of power consumption to light output for the three standard lights is shown in Table 6. Again, it is evident that LEDs produce the same amount of light as CFLs and incandescent bulbs for two times and ten times less power, respectively.

**Table 6 - Light Output Comparison**

<b>Light Output</b>	<b>LEDs</b>	<b>CFLs</b>	<b>Incandescents</b>
<b>Lumens</b>	Watts	Watts	Watts
450	<b>4 - 5</b>	<b>8 -12</b>	<b>40</b>
300 - 900	<b>6 - 8</b>	<b>13 - 18</b>	<b>60</b>
1100 - 1300	<b>9 -13</b>	<b>18 - 22</b>	<b>75 - 100</b>
1600 - 1800	<b>16 - 20</b>	<b>23 - 30</b>	<b>100</b>
2600 - 2800	<b>25 - 28</b>	<b>30 - 55</b>	<b>150</b>

However, the automotive industry (especially ambulances) has strict guidelines with regarding to temperature, humidity range, ability to withstand adverse environments, electromagnetic interference (EMI), and voltage protection circuitry. They also must pass reliability requirements, such as AEC-Q100 for all LED driver ICs. This is a critical stress test qualification for all automotive applications, not just ambulances [28].

Just a decade ago it would not have been practical to consider using LEDs for so many automotive purposes because of their limited temperature range, low light output levels, and illumination only in a select few colors like red and green. But the exponential increase in LED technology has overcome most of these challenges already, and will continue to improve in the near future. The EPA estimated that the light output level from LED devices roughly doubles every 18 months. As the efficiency increases and the cost decreases, it's inevitable that LEDs will eventually replace all other traditional lighting technologies [28].

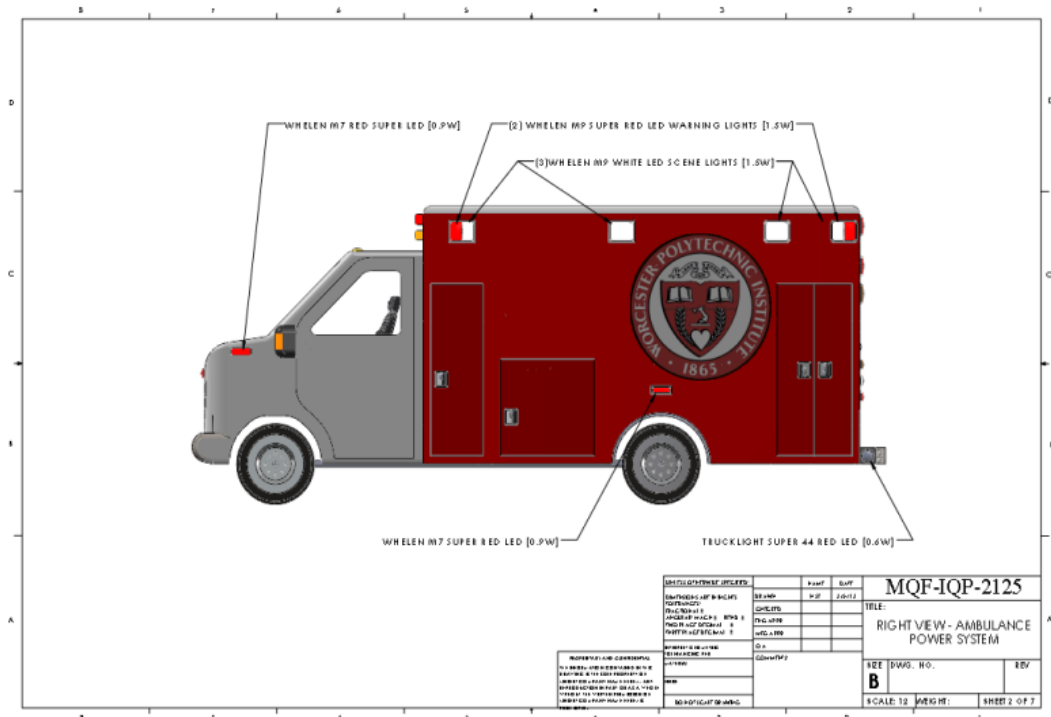

Figure 36 - Right View

Typical applications of LEDs within an ambulance include instrument backlighting, dome lights, courtesy lights, and all patient compartment lights (as long as they meet the design specifications outlined in the standards shown in appendix A-C). Exterior applications include headlights, turn signals, brake lights, side marker lights, fog lamps, daytime running lights, and of course all emergency lights. In Figure 36 through Figure 42 the locations of all interior and exterior lights are shown, with the power consumption specified for each individual light using Whelen® standard LED lights [29].

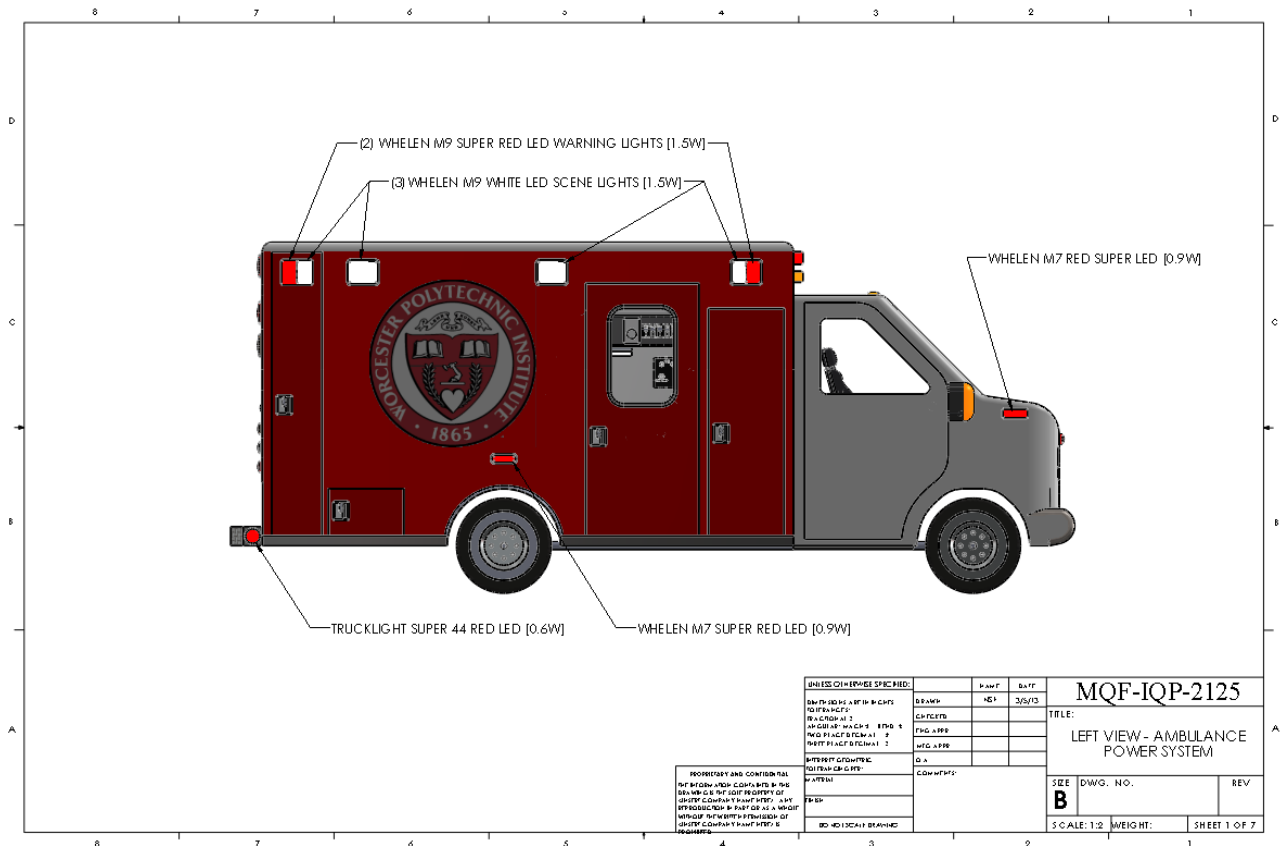

Figure 37 - Left View

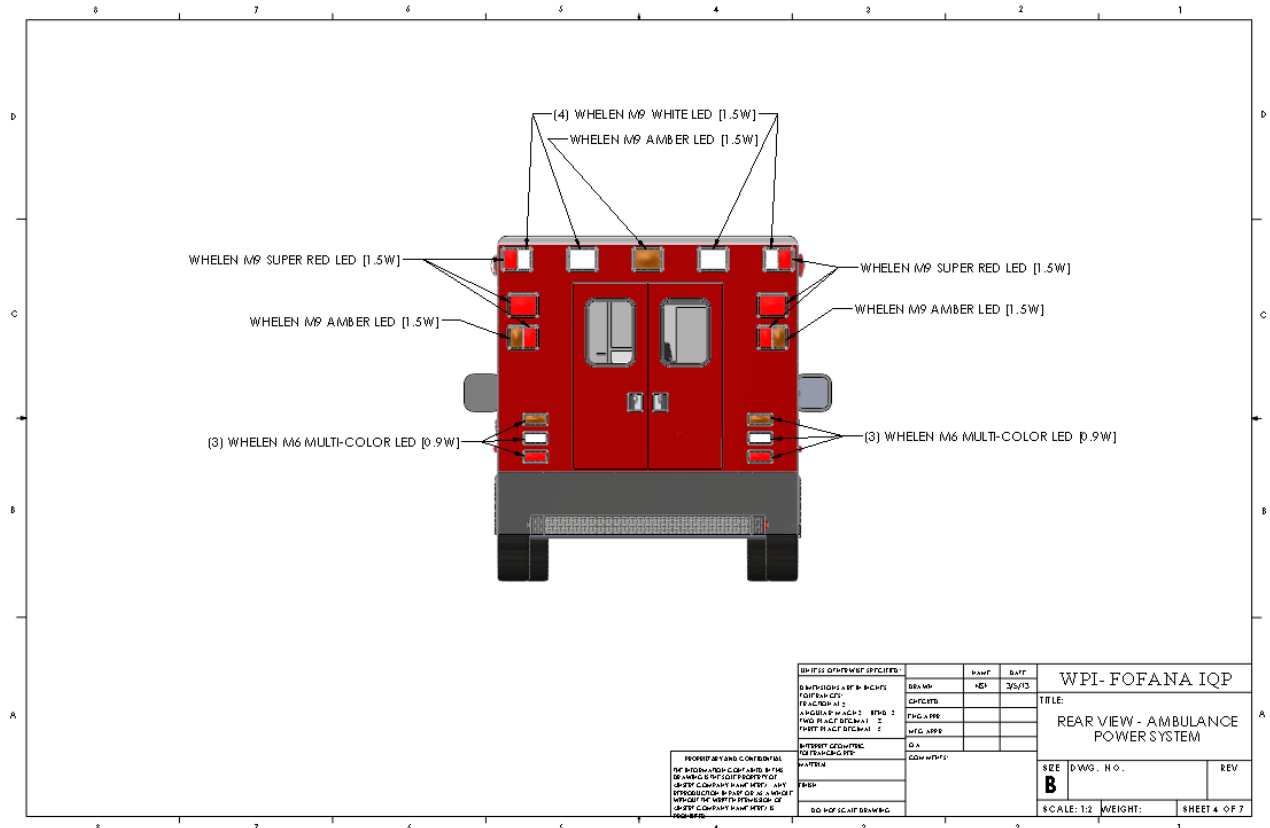

Figure 39 - Rear View

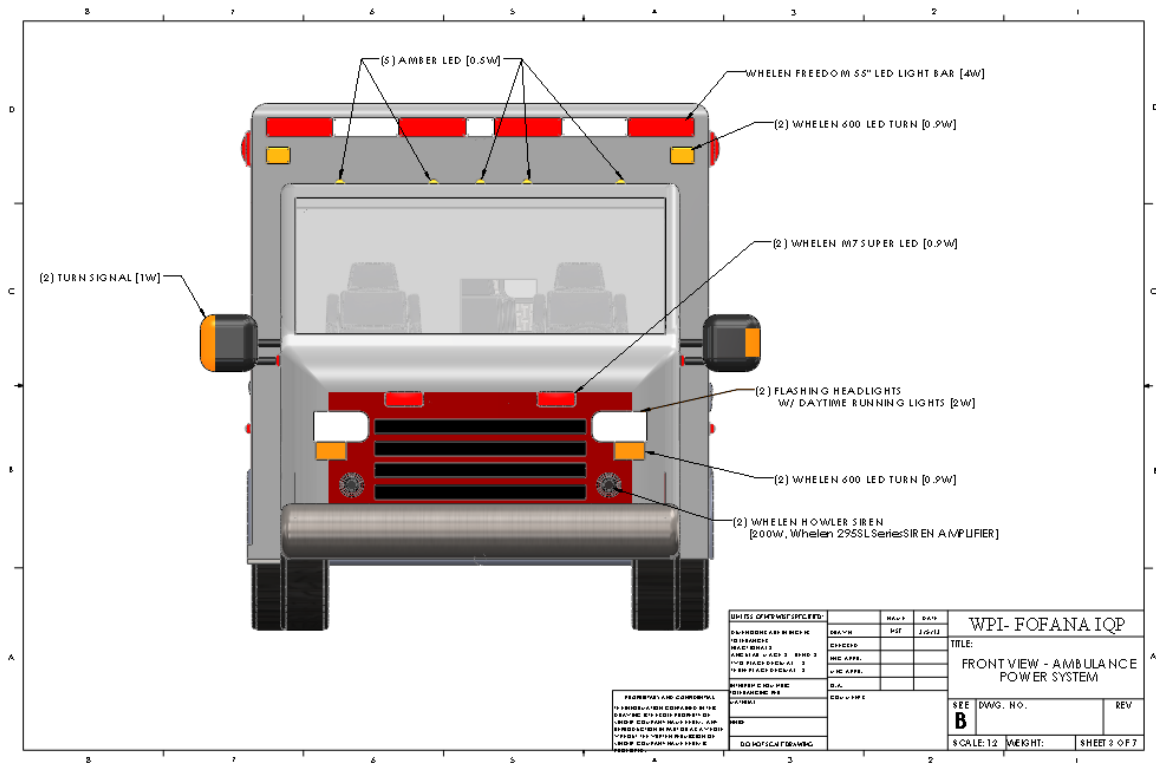

Figure 38 - Front View

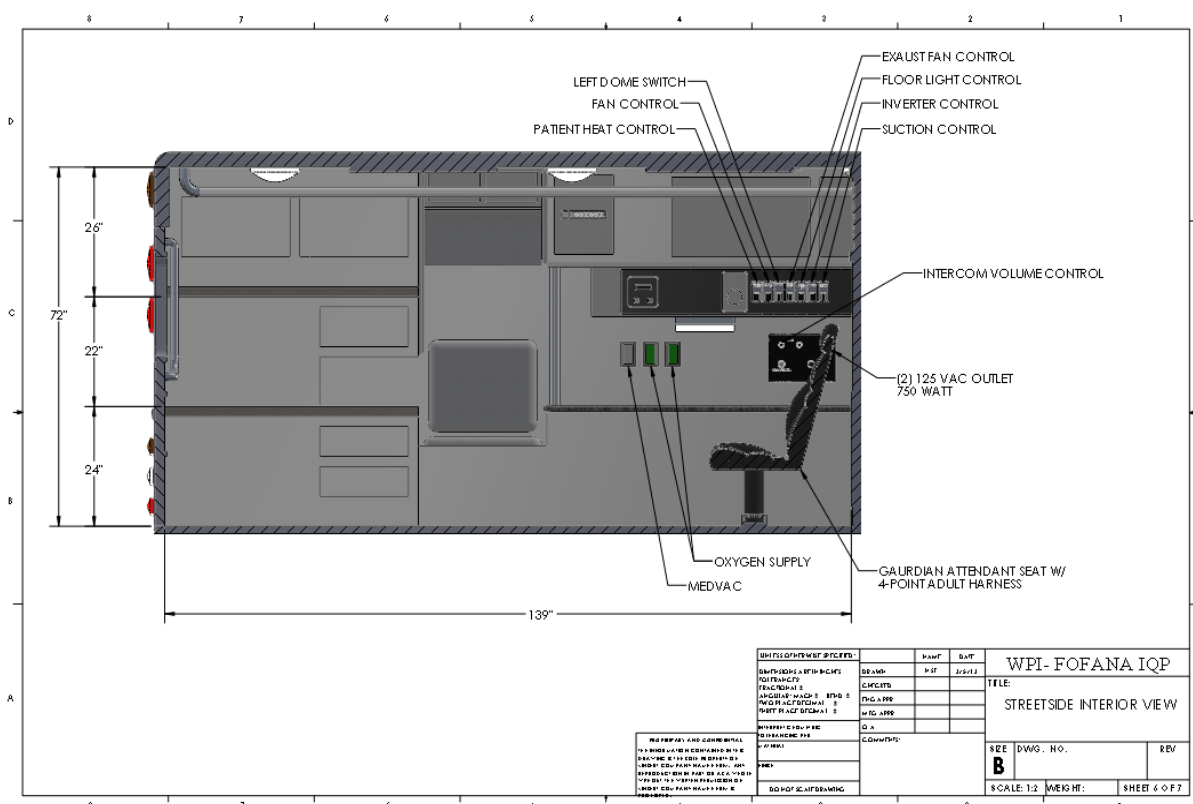

Figure 41 - Street Side Interior View

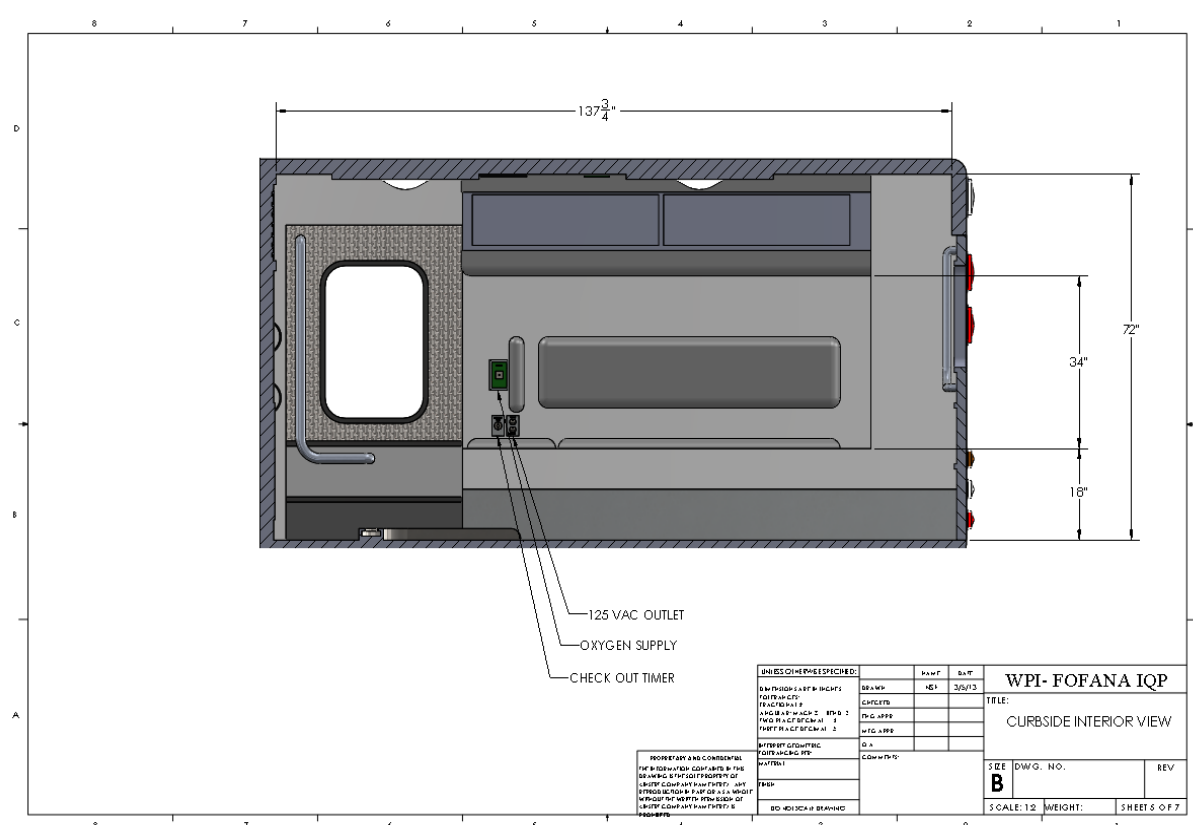
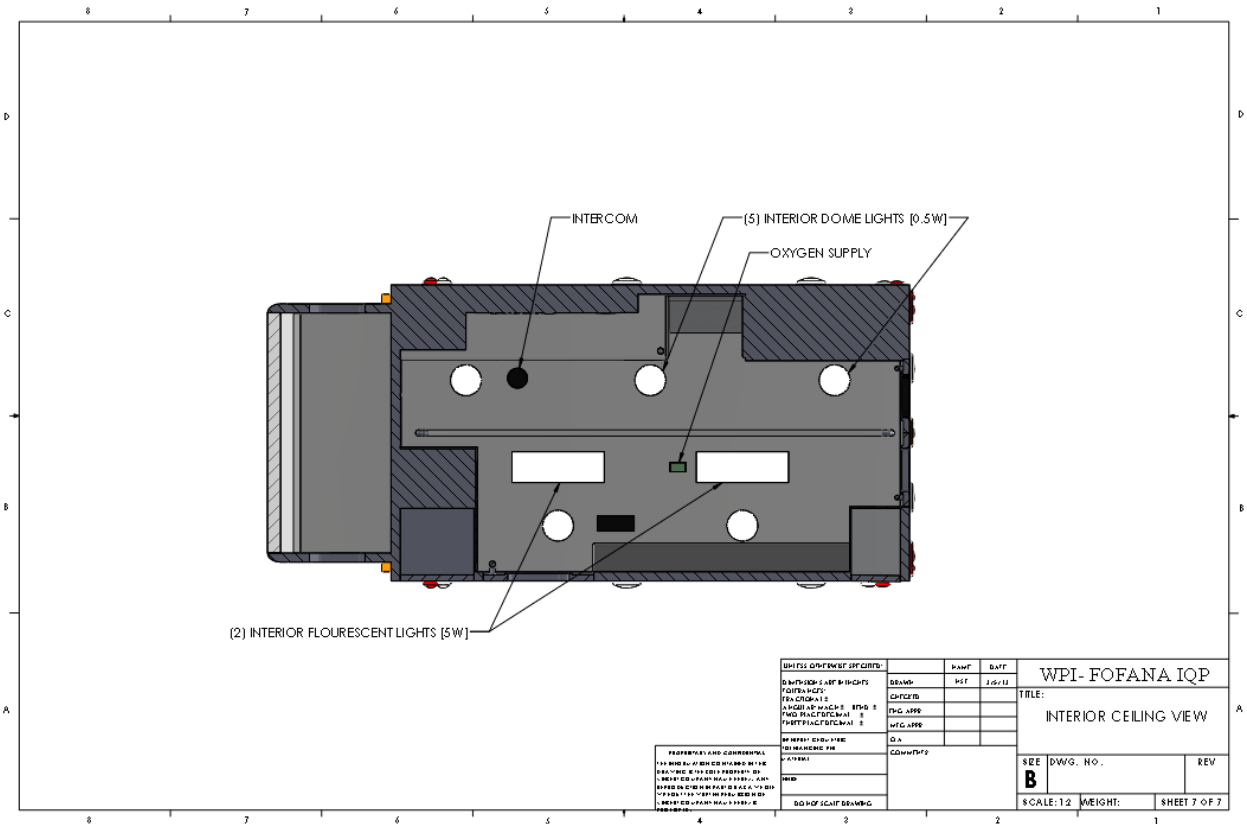

Figure 40 - Curbside Interior View





**Figure 42 - Interior Ceiling Lights**

This remarkable technology is quickly becoming the standard in automotive lighting industries, for obvious reasons. As LEDs become cheaper and even more efficient they will soon become the customary choice for all lighting industries.

### 3.2.4 Air Turbines

New developments in turbine technology have made wind generated electricity more attractive in recent years. While the global race for a practical source of renewable energy is on, there has been a boom in funding for research and development of wind turbines. This funding has allowed an exponential growth in the large scale implementation of wind farms throughout the world, with a growth rate of about 30% per year in the wind power industry [30].

Air turbines work by utilizing wind velocity to turn aerodynamic blades, which spin a shaft connected to a generator (or alternator), which creates electricity. A diagram of a typical wind turbine is shown in Figure 43. The efficiency of this system depends on the air velocity,

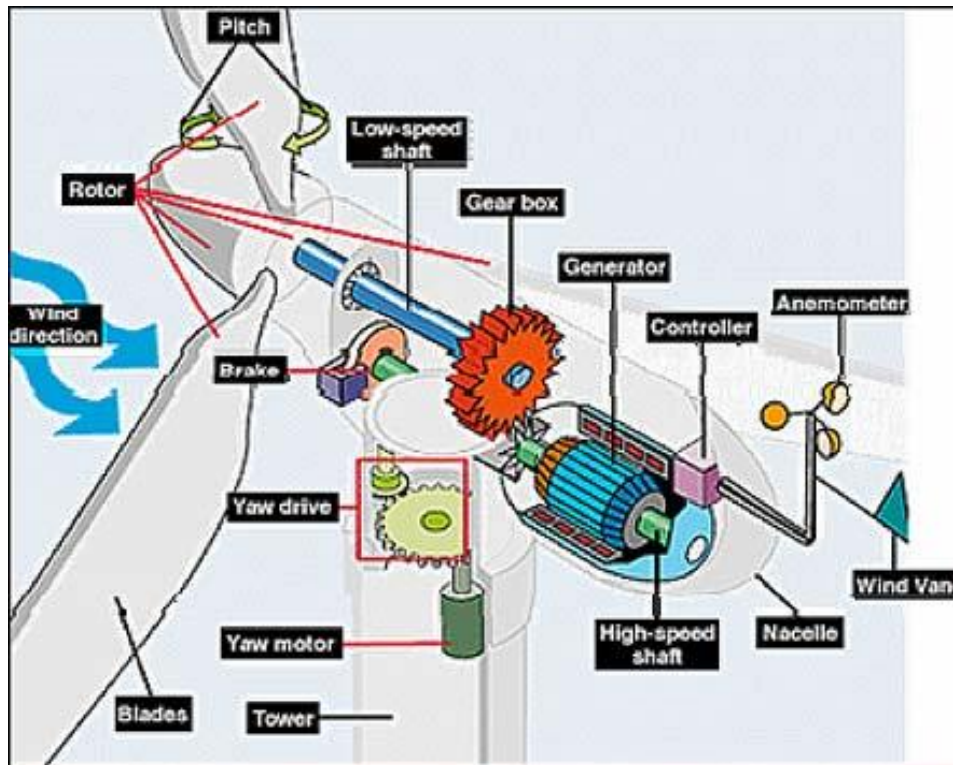

**Figure 43 - Air Turbine Break-down [31]**

wind direction, blade geometry, and generator efficiency.

The implementation of air turbines on vehicles is not a new concept. In the Netherlands there is an annual competition in which several universities from all over the world race to build the best and fastest wind powered vehicle. In 2008 the Ventomobile won first prize, which is a solely wind powered lightweight three-wheeler which can be seen in Figure 44 [33]. Clearly, a turbine of this size implemented into a typical street vehicle would not be very practical. A more expensive, but more compact and efficient, method of harnessing wind power is to use a micro turbine as shown in Figure 45. In 2009 a

performance super car was designed in California which uses solar power to start up and later draws its current through air circulation. This car has four air intakes tactically built into the car's bodywork which direct the air into the turbine. The turbine is connected to an alternator which boosts the available electricity within the car [32]. This is an incredible innovation which proves that turbine generated electricity has the potential to be implemented into vehicles.



**Figure 44 - The InVentus Ventomobile**

The drawbacks of vehicular air turbines are that they are usually bulky, create significant air resistance (which lowers fuel efficiency) and require substantial wind speeds in order to generate a significant amount of energy. The super car supposedly can reach speeds of 155 mph, which is definitely fast enough to create a considerable amount of electricity. This is obviously not

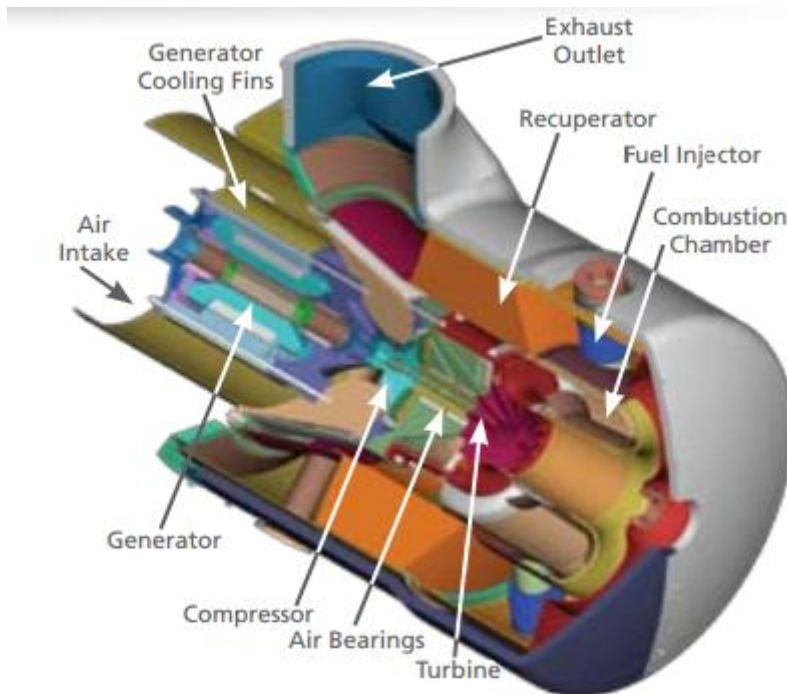
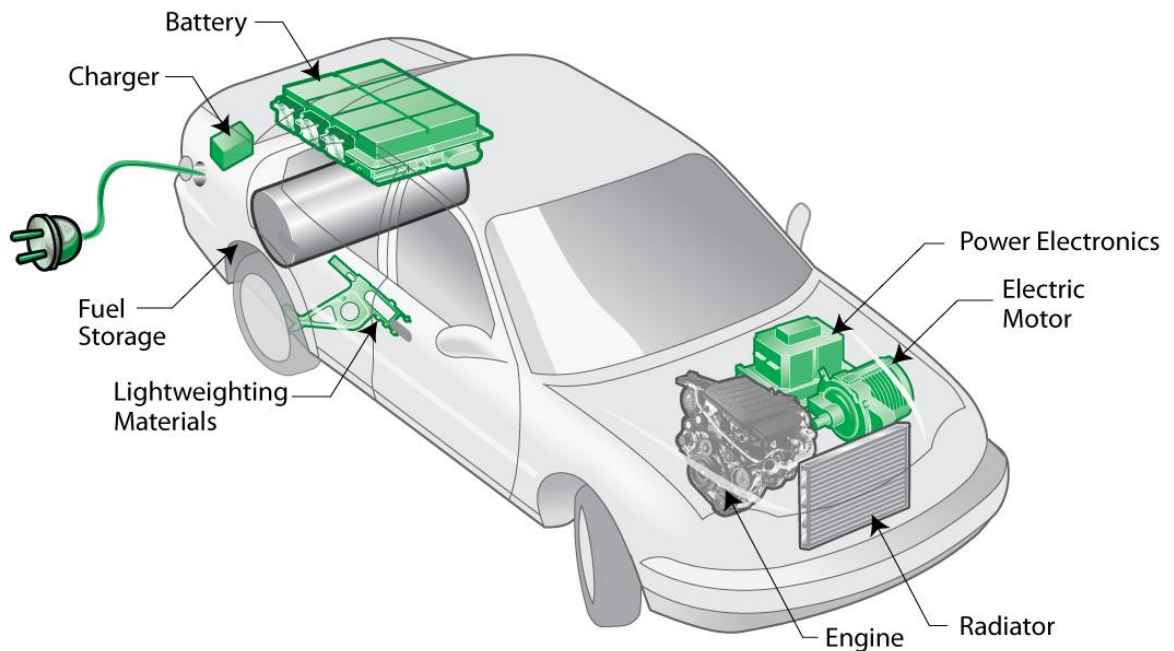

**Figure 45 - CMT-380 Microturbine**

the case for the ambulance.

### 3.2.5 Lithium Ion Batteries

The ambulance service is required to have a number of backup ambulances at a maintained readiness. This effectively means that there is a set amount of ambulances with long idle time. As a result, full operation of the OEM and the external equipment is not always practically possible, due to the natural discharge of the 2 (two) lead-acid batteries the ambulance is equipped with [34].



**Figure 46 - PHEV Configuration**

A solution that is both environmentally friendly and cost effective is to switch the vehicle type from an all-petroleum vehicle to a plug-in hybrid electric vehicle (PHEV). A basic configuration diagram is shown in Figure 46. A plug-in hybrid electric vehicle (PHEV) is a hybrid which has additional battery capacity and the ability to be recharged from an external electrical outlet [34]. This solution utilizes two traits of the ambulance usage: long

idle times and short distances travelled. Idle time can be utilized to keep the rechargeable battery at full capacity and the short distances can be covered by purely electrical power, minimizing fuel usage.

Starting, it is clear that the use of batteries with low discharge rate is essential. The most widely spread options are the lithium-ion (Li-ion) and nickel metal hydride (NiMH) batteries [34]. This expansion of the latter types of batteries coincides with the progression toward hybrid and electronic powered cars in the automotive industry<sup>1</sup>. Also, most analysts predict that the oil and gasoline prices will not drop in the near future, making the use of efficient rechargeable batteries more favorable. Some argue that PHEVs will become the hybrid vehicle of choice.

Issues currently faced are the battery life, heat dissipation, cost, capacity, weight, and safety factor. However, advanced battery technology promises drastic increases in the energy density of new batteries (such as the nano-titanate battery already used in military applications, and commercially utilized by Mitsubishi i-MiEV) [35].

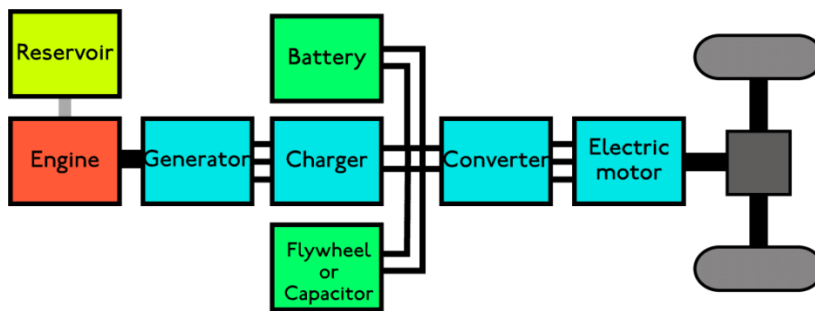

**Figure 47 - Drivetrain Options**

---

<sup>1</sup> Johnson Controls, a global company offering products and services to optimize operational efficiencies of automotive batteries, has announced its partnership with Ford in February 2009. As a result, the company's first lithium-ion power plant in the US opening has been planned.

As shown in Figure 47, there are two basic configurations for the PHEVs: Series and Parallel (or Power-split which utilizes both series and parallel) [35]. The series PHEV (also called Extended Range Electric Vehicles or EREV) is capable of operating only on electricity for a limited distance (Extended Range). Within the extended range, the electric motor is the only part that turns the wheels, whereas the engine only supplies the generator. Once the battery is depleted the engine takes over and generates the power to sustain the electric motor. Therefore, it is possible for this configuration to use no gasoline for short trips.



**Figure 48 - Series PHEV**

As seen in Figure 48, the series PHEV is driven only by electric traction. The electric motor is superior to the piston internal combustion engine by having a greater power to weight ratio. Additionally, since the motor drives the wheels directly, a mechanical transmission, gearbox and transmission shafts are not needed. Consequently, the weight of the vehicle is significantly reduced by switching to an electric motor.

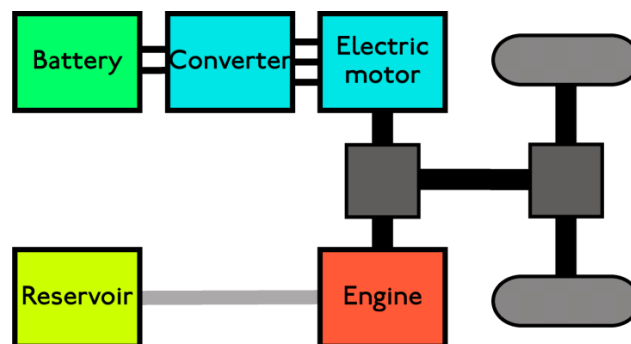

**Figure 49 - Parallel PHEV**

In the Parallel configuration (Figure 49), both the engine and the electric motor are mechanically connected to the wheels, simultaneously transmitting power. The electric drive can be programmed to substitute the engine at low speeds where the torque requirements can be met by the motor.

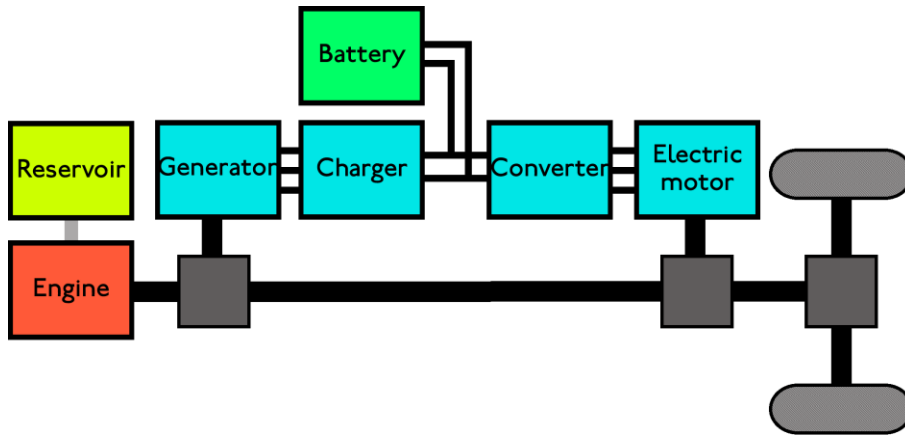

**Figure 50 - Power-split PHEV**

A Power-split structure (Figure 50) uses both series and parallel configurations, having both a mechanical and electrical connection with the differential [35]. It has the flexibility to alternate between the usage of the engine and the motor depending on the driving conditions.

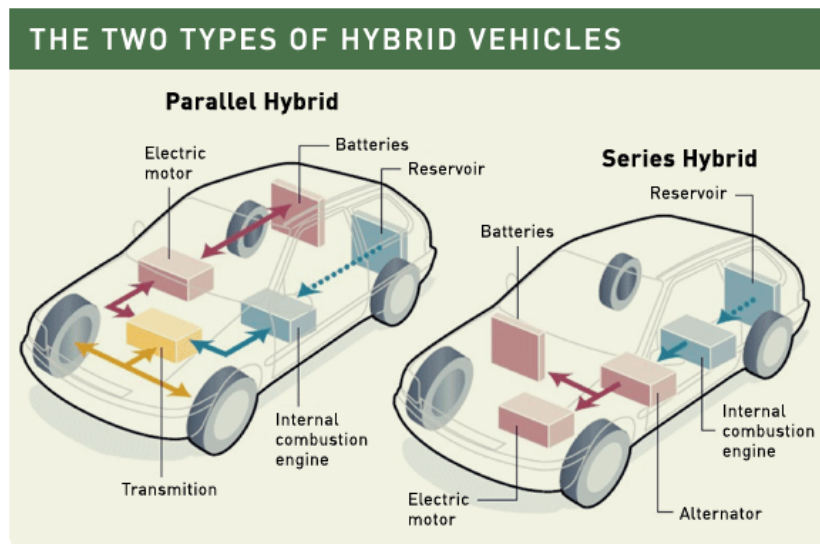

**Figure 51 - Series v. Parallel Hybrids**



Despite the early stages of expansion of the PHEV, some commercial success has been achieved. Namely, Chevrolet Volt (a series PHEV), which debuted in 2007 and commenced sales 2011, has sold more than 40,000 units by January 2013 [36]. The vehicle utilizes a 16.5 kWh Li-ion battery (10.4 kWh actual at 45 A·h) and an electric motor with a peak of 111 kW (149 hp) for the electronic mode. Once the battery charge has dropped to a certain threshold, the internal combustion engine, rated at 60 kW (80 hp) powers the generator (54 kWh) which sends the power to the motor and any excess to the battery bank (that acts as a buffer) [37]. For situations that require high power output such as high vehicle speeds or prolonged acceleration, the vehicle switches to a **dual motor extended mode** and acts as a regular hybrid, utilizing both the battery charge and the fuel. The result is a combined efficiency of 62 mpg. An interesting EPA study of fuel economy and environmental comparisons is shown in Figure 52, which shows the drastic savings and reduced environmental impact of electric vehicles.

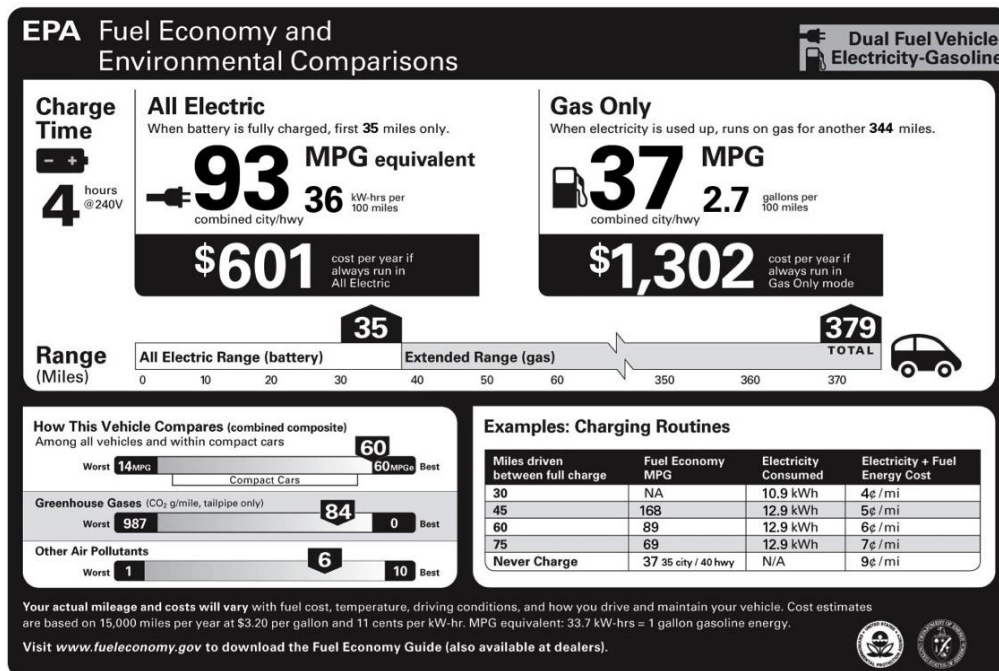
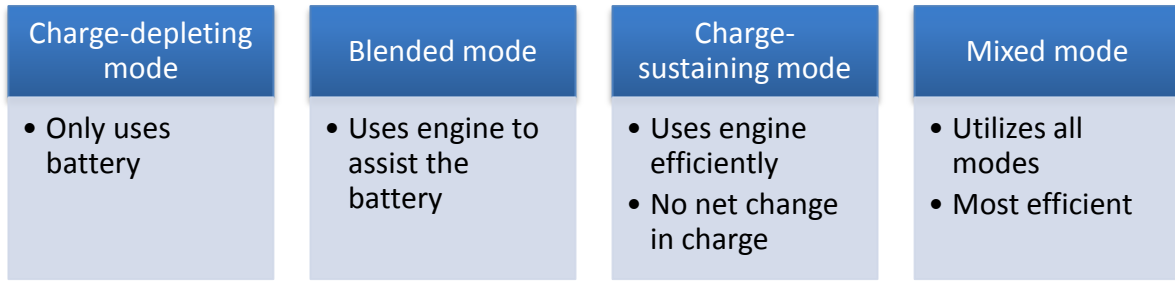

Figure 52 - EPA Fuel Economy Comparisons





**Figure 53 - Hybrid Modes of Operation**

As summarized in above in Figure 53, the **charge-depleting mode** allows the PHEV to operate exclusively on electric power until the battery is drained. Considering the short distances covered by the ambulance, this is the ideal mode of operation as it minimizes the fuel usage.

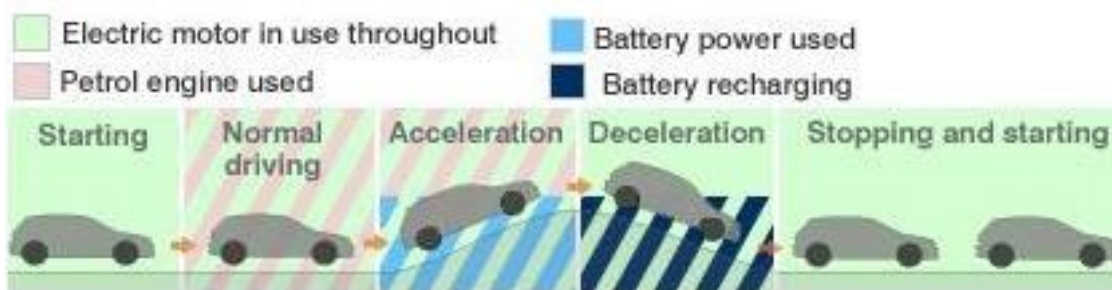

**Figure 54 - Typical driving distribution of electric v. petrol**

The **blended mode** involves the use of the combustion engine within the all-electric range. This mode is used when a higher power output is required. In essence, the combustion engine starts contributing to the torque when a certain RPM or absolute speed number is reached.

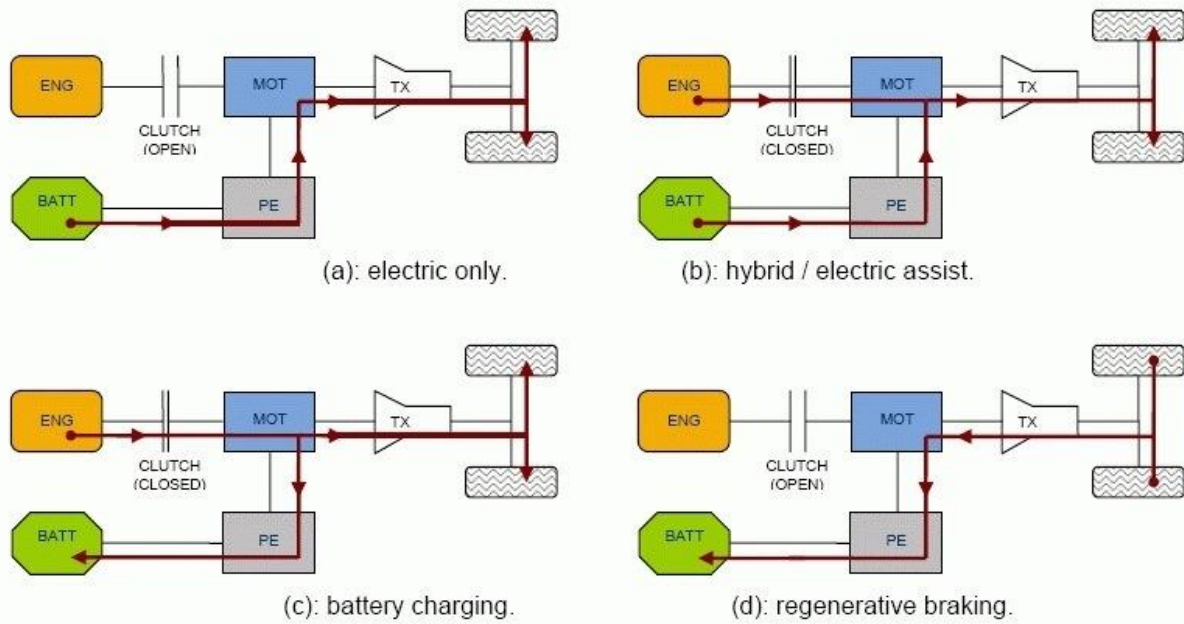

**Figure 55 - Functional Diagram of Various Modes of Operation**

The **charge-sustaining mode** is mostly used in regular hybrid electric vehicles. It uses both the engine and the motor as efficiently as possible without allowing the battery to discharge. Therefore, for conventional hybrids the battery plays the role of an accumulator and experiences no change in charge through the trip. For plug-ins, however, this mode can be turned on once the battery has been depleted by the charge-depleting mode.

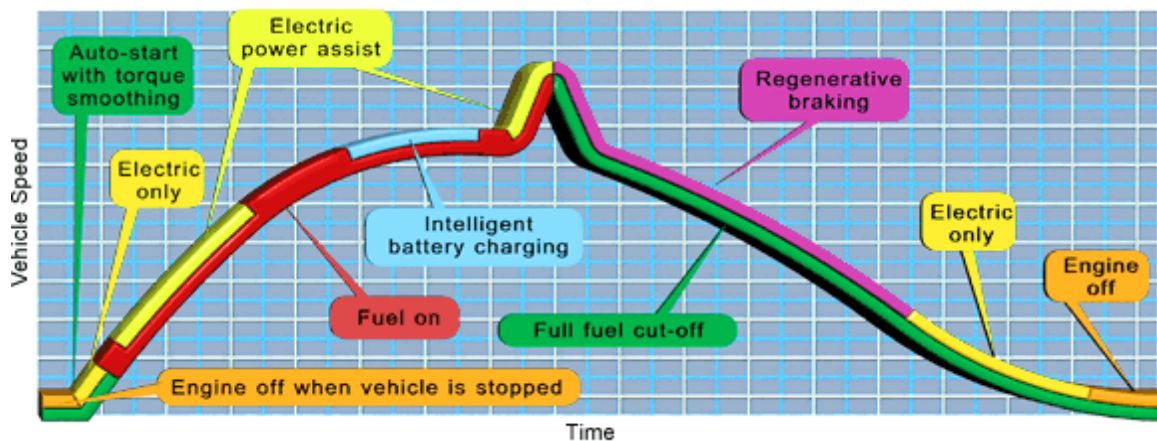

**Figure 56 - GM Next-Generation Hybrid System**

A **mixed mode** utilizes all three of the above modes depending on the driving conditions and the trip planned. Ideally, it is the most efficient mode if used correctly.

Currently, Li-ion and lithium polymer are the batteries of choice to power the next generation of electric vehicles. This is mainly attributed to the many advantages they have over their heavier competitors. The batteries required for the electric power storage of PHEVs have higher requirements than those of conventional hybrids. This is due to the fact that the PHEV batteries are designed to be fully depleted, performing more cycles thus, reducing the battery life. In the case of the best selling plug-in hybrid currently, Chevrolet Volt, a Li-ion battery is utilized [37]. A typical lithium ion battery consists of the components shown in Figure 57.

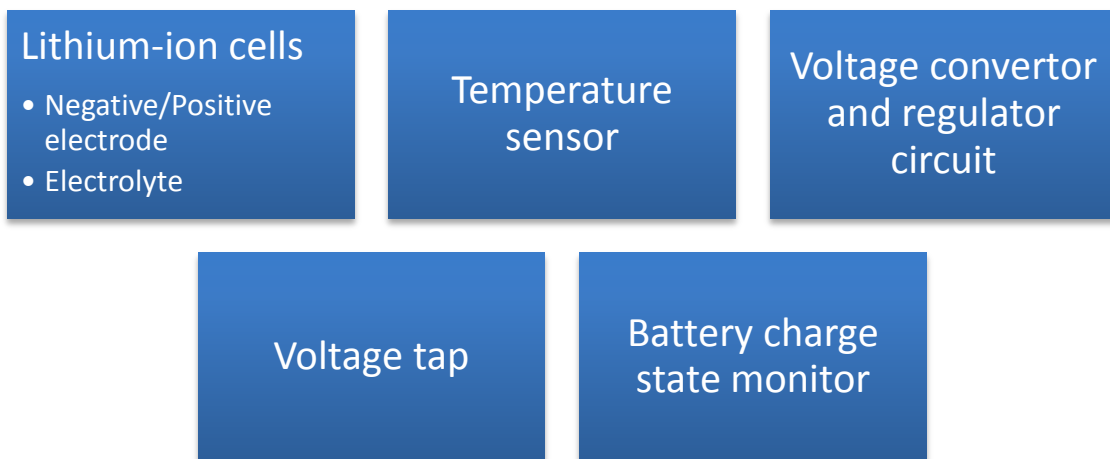
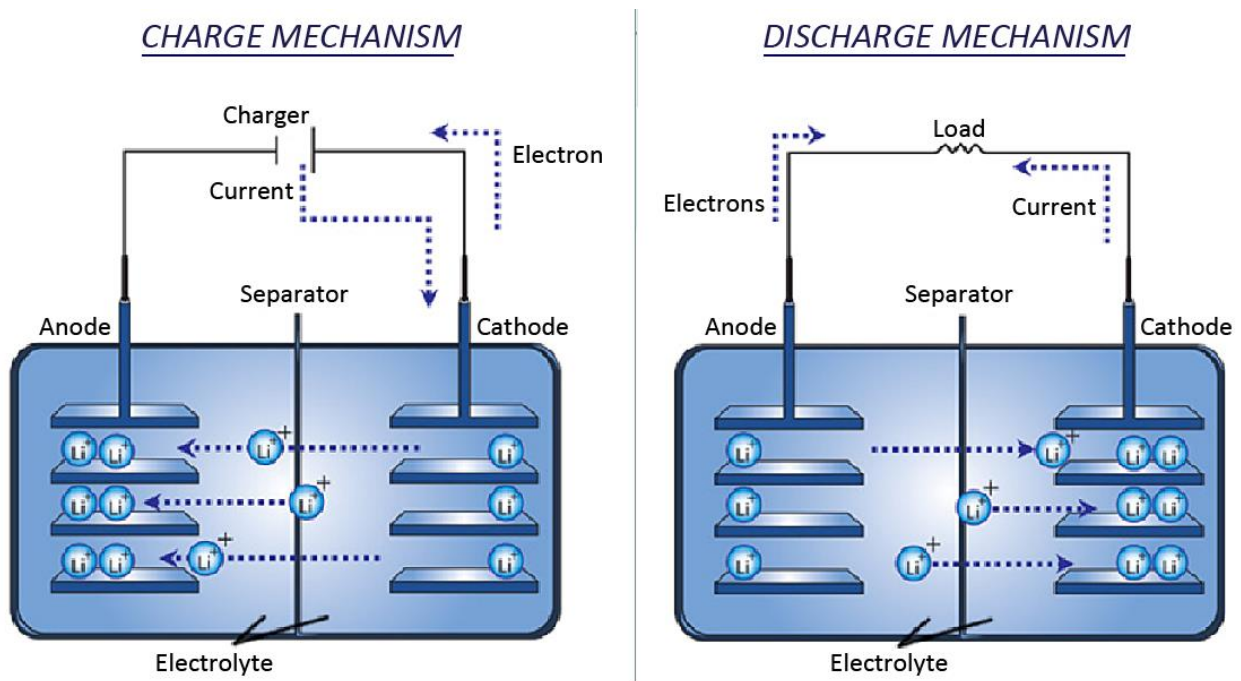

**Figure 57 - Lithium Ion Battery Components**

The lithium-ion cells can be available in various formats. For the purpose of powering electric vehicles, cylindrical cells are preferred due to their large threaded terminals (prismatic ones are also used by some manufacturers) [35]. The three primary components of the cells are the negative electrode, the positive electrode and the electrolyte. This structure is surrounded by a metallic case that ensures that proper conditions of pressure and temperature are met. If the

battery is overheated, a safety valve on the case will open in order to release the extra pressure and avoid an explosion.

The energy provided by the Li-ion battery is dependant on the chemistry of the reaction. Various materials can be used for the construction of the cell, each having their advantages and disadvantages. Overall, the reaction follows the process of intercalation. During discharge, Li-ions are extracted and transferred across the electrolyte into the crystal lattice of the positive electrode without changing the crystal structure, as shown in Figure 58.



**Figure 58 – Intercalation Cycle**

The positive electrode is a metal oxide, usually a polyanion such as lithium iron phosphate ( $\text{LiFePO}_4$ ) [35]**Error! Reference source not found.** Other materials that are currently not applicable in the automotive industry include lithium cobalt oxide (material of choice for laptops, cell phones, etc.) and lithium manganese oxide. Constant advancements in the field of batteries have produced cathodes such as the lithium purpurin cathode, which has a low production cost; since purpuring can be synthesized, being an organic material. Another

lithium battery that has a viable commercial implementation is the lithium air battery. A lithium air battery has the ability to surpass the current batteries in the near future. The requirements for the type of oxide used can be found below in Figure 59

#### Manufacturability

- Sufficiently thin (<50  $\mu\text{m}$ )
- Pinhole free
- Low cost

#### Mechanical Properties

- High elastic modulus
- High flexibility for wound concepts

#### Stability

- Stable against Li
- Water stable

#### Catalysts

- High activity/mass ratio
- High activity/cost ratio

#### Electrolyte

- Adequate  $\text{Li}^+$  conductivity at all temperatures
- Good stability at high temperatures
- Low viscosity

**Figure 59 – Oxide Requirements**

For the purpose of investigation, most metal oxide applicable for the cathode will be compared in Table 7.

**Table 7 - Comparison of Metal Oxide Cathodes**

System	NCA-graphite	LFP-graphite	MS-TiO	MNS-TiO	MN-Graphite
Electrodes Positive Negative	$\text{LiNi}_{0.8}\text{Co}_{0.15}\text{Al}_{0.05}\text{O}_2$ Graphite	$\text{LiFePO}_4$ Graphite	$\text{LiMn}_2\text{O}_4$ $\text{Li}_4\text{Ti}_5\text{O}_{12}$	$\text{LiMn}_{1.5}\text{Ni}_{0.5}\text{O}_4$ $\text{Li}_4\text{Ti}_5\text{O}_{12}$	$\text{Li}_{1.2}\text{Mn}_{0.6}\text{Ni}_{0.2}\text{O}_2$ Graphite
Capacity, mAh/g Positive Negative	155 290	162 290	100 170	130 170	275 290
Voltage 50% SOC	3.6	3.35	2.52	3.14	3.9
Safety	Fair	Good	Excellent	Excellent	Excellent
Life Potential	Good	Good	Excellent	Unknown	Unknown
Cost Status	Moderate Pilot Scale	Moderate Pilot Scale	Low Develop.	Moderate Research	Moderate Research

**Li-cobalt**<sup>2</sup> (Lithium Cobalt Oxide,  $\text{LiCoO}_2$ ) can only be charged at the rating provided by the manufacturer. Applying a higher load may result in overheating and explosion. The voltage regulator circuit limits the charge and discharge to a level of 1C. Due to this, this technology is not applicable in the automotive industry as the conditions are much

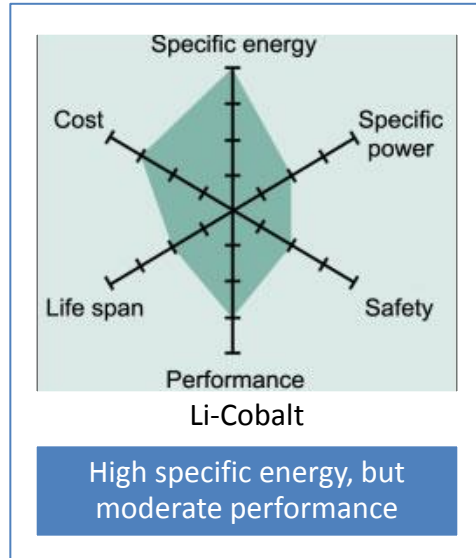

harsher and fast charge/discharge is often required. As a result, Li-Cobalt is mostly used for phones, laptops and digital cameras. Finally, the internal impedance of the cobalt cell increases with time making it significantly susceptible to aging.

**Li-Manganese** (Lithium Manganese Oxide,  $\text{LiMn}_2\text{O}_4$ ) has a low internal cell resistance, allowing fast charging (average of 25A) compared to the preceding Li-cobalt type. Li-Manganese has the flexibility to sacrifice some attributes for others; in essence, an electric powertrain would utilize the longevity and high specific power, while sacrificing runtime.

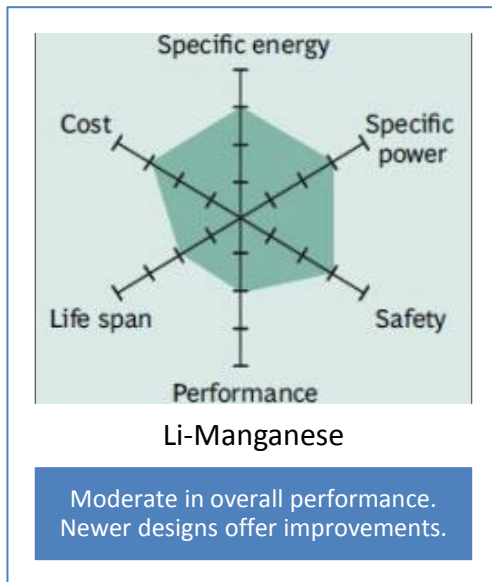

<sup>2</sup> Note that Li-cobalt type batteries are currently not applicable in the automotive industry. However, this type of cell is mentioned for comparison purposes.

**Li-Phosphate** (Lithium Iron Phosphate,  $\text{LiFePO}_4$ ) type batteries were first introduced in 1996; thus the technology is still in infancy. The main advantage of Li-Phosphate batteries is the high life span. The cells have a moderate density with an output of 70A and have the ability to operate at high temperatures ( $>60^\circ\text{C}$ ). However, thermal instability and high self-discharge rate lead to imbalanced batteries in the long run.

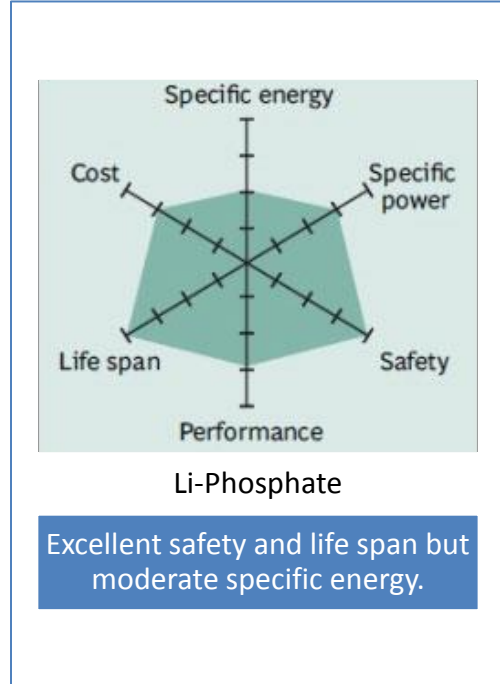

**NMC** (Lithium Nickel Manganese Cobalt Oxide,  $\text{LiNiMnCoO}_2$ ) is a hybrid type of battery utilizing the qualities of both nickel and manganese. It has the same flexibility with Li-Manganese type batteries, allowing manufacturers to trade between high specific energy and high specific power. The combination with nickel counters the low specific energy offered by manganese. Finally, by minimizing the use of cobalt, it is possible to achieve lower cost of manufacturing.

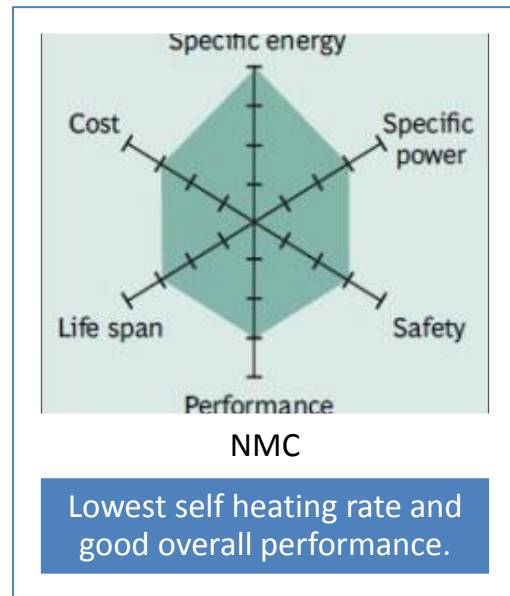



**NCA** (Lithium Nickel Cobalt Aluminum Oxide,  $\text{LiNiCoAlO}_2$ ) is slowly getting the attention of the automotive industry due to its excellent energy and power attributes. Replacing manganese with low-cost aluminum, drops the cost of the cell significantly. However, the NCA cathode has a tendency to release oxygen, which results in oxidizing the electrode.

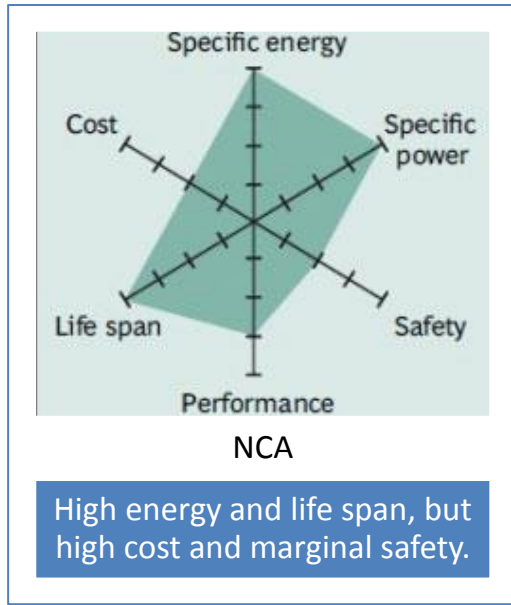

**Li-Titanate** (Lithium Titanate,  $\text{Li}_4\text{Ti}_5\text{O}_{12}$ ) cells have been known to the industry since 1980. Their power attributes are very competitive and can be combined with the appropriate cathode and provide excellent low-temperature performance and a long life span.

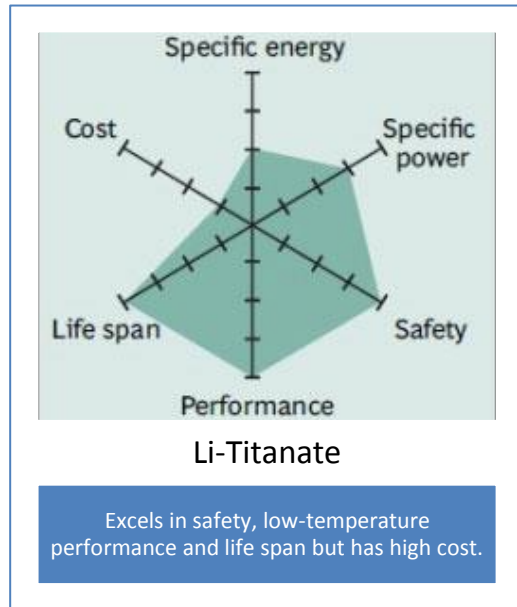

For the sake of comparison, Figure 61 shows a graph ranging the specific energies of various batteries:

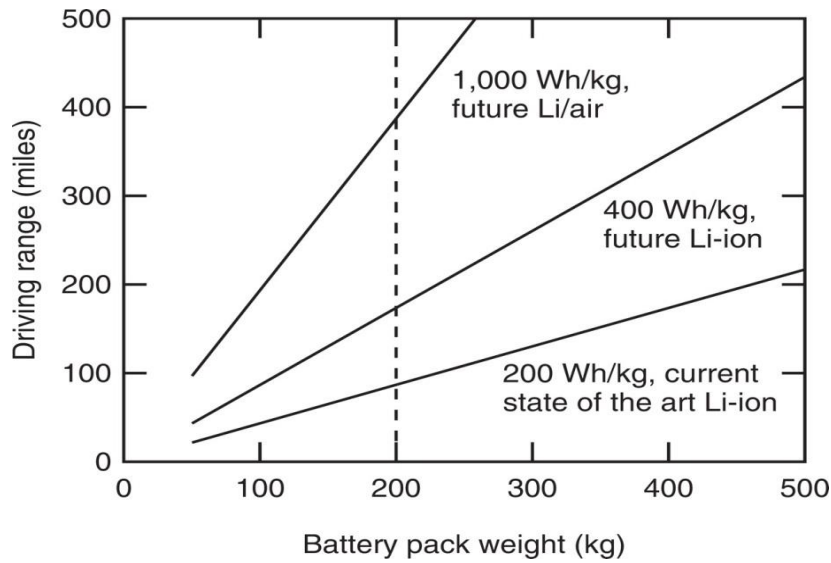

**Figure 60 - Battery Weight v. Driving Range**

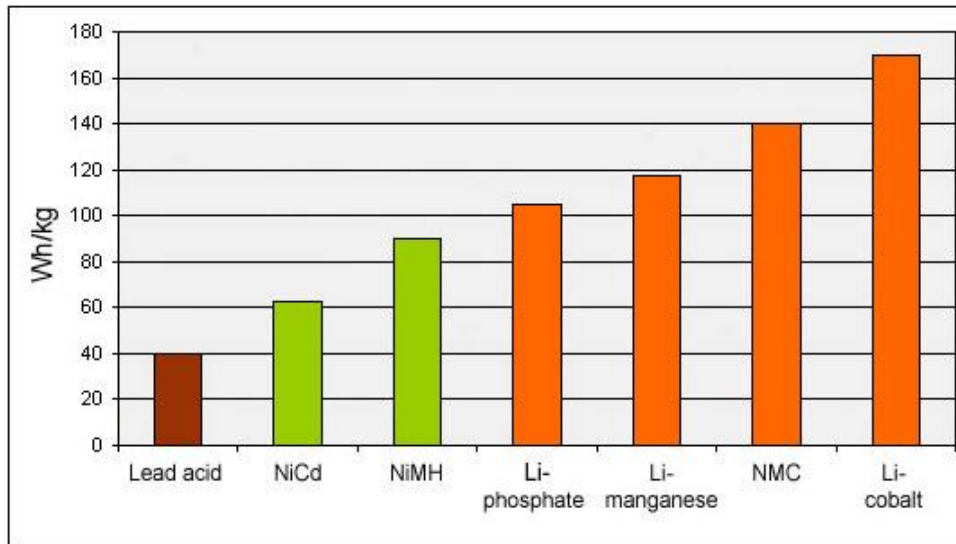

**Figure 61 – Specific Energies of Various Batteries**

Lithium air batteries, is another alternative to the lithium-metal-oxide configuration. They have high theoretical specific energies and the low cost of materials can make them the leading competitor in long range electric vehicles.

As seen in Figure 60, a lithium air battery pack of 200kg can achieve a driving range of 400 miles in the near future. For this study, it is assumed that the battery cells weight 70% of the battery pack and have a 83% energy efficiency.

**Table 8 - Physical Properties of Various Li/air & Li-ion Positive-Electrode Active Materials**

Active Material	Specific capacity (mAh.g)	Density (g/cm <sup>3</sup> )	Capacity density (mAh/cm <sup>3</sup> )	U <sup>0</sup> vs. Li metal (V)	Theoretical specific energy (vs. Li metal) (kWh/kg)	Theoretical energy density (vs. Li metal) (kWh/L)
Li <sub>2</sub> O	1794	2.01	3606	2.91	5.22	10.49
Li <sub>2</sub> O <sub>2</sub>	1168	2.31	2698	2.96	3.46	7.99
LiOH·H <sub>2</sub> O	639	1.51	965	3.45	2.20	3.33
LiOH	1119	1.46	1634	3.45	3.86	5.60
LiMO <sub>2</sub> , <sup>3</sup>	275	4.25	1169	3.75	1.03	4.36
LiFePO <sub>4</sub>	170	3.60	612	3.42	0.58	2.09
Li metal	3861	0.534	2062	0	0	0

In Table 8, the physical properties of various Li/air and Li-ion cathode materials are summarized. By comparison, the following graph is obtained:

---

<sup>3</sup> M = Mn, Ni, Co

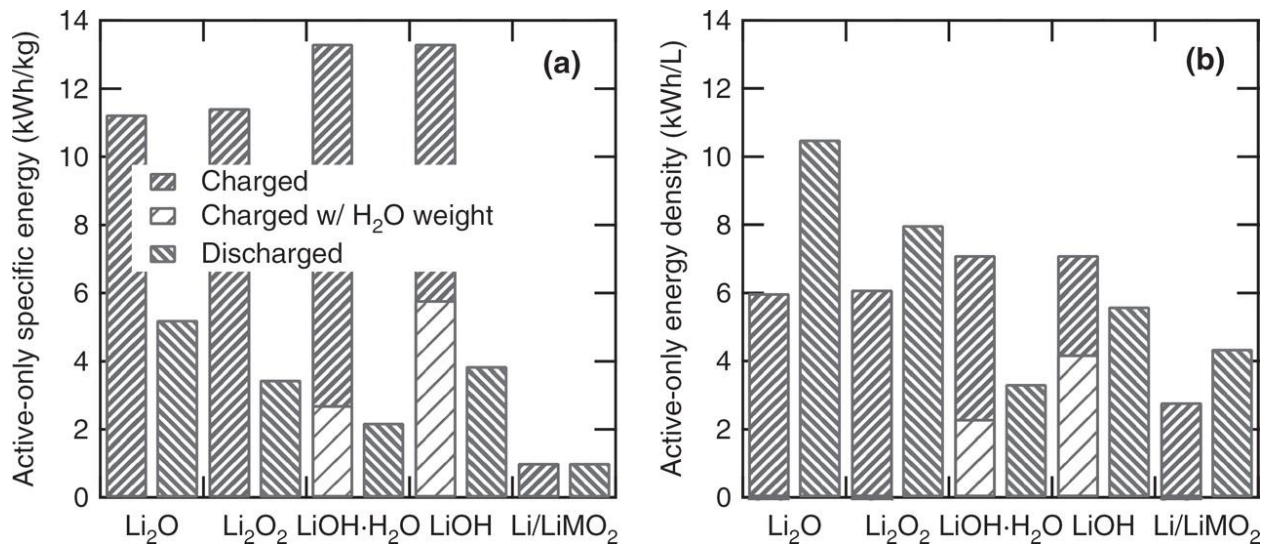
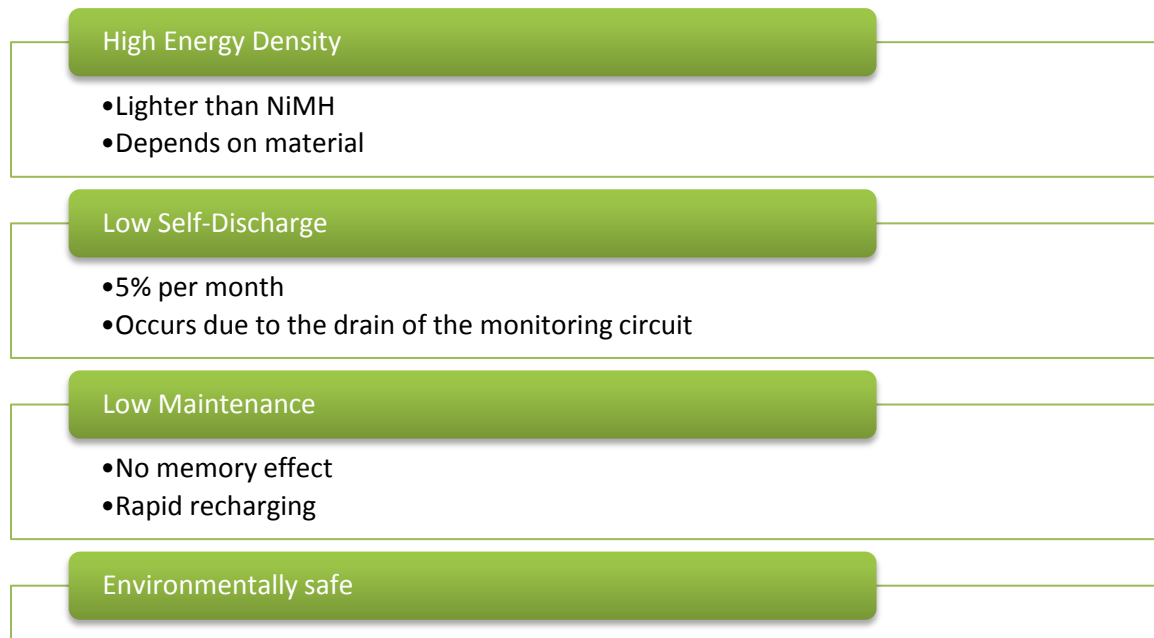

**Figure 62 - Specific Energy and Energy Density**

When examining Figure 62, one should note that while specific energy is important, energy density can be just as important in automotive and other applications. Therefore, if only specific energy is considered the advantages of Li/air cells are greater due to their low density compared to the metal oxide materials.

The batteries required for the electric power storage of PHEV's have higher requirements than those of conventional hybrids. This is due to the fact that the PHEV batteries are designed to be fully depleted and perform more cycles, thus reducing the battery life. In the case of the current best selling plug-in hybrid, Chevrolet Volt, a Li-ion battery is utilized.

The development of deep cycle batteries (used for hybrid cars) has yielded great results in the case of Li-ion type batteries, which have many advantages over the traditionally used NiMH batteries. In Figure 63 below, some important aspects and advantages of Li-ion batteries are summarized.



**Figure 63 - Advantages of Li-ion Batteries**

Li-ion batteries are smaller and weigh less than NiMH batteries. This is very important for a hybrid vehicle that is trying to overcome the vehicle's inertia at the all-electric range. The smaller size combined with the high energy density (250-750 W·h/L) improves the mileage of the vehicle. The performance of the Li-ion battery depends on the materials used and is constantly improving [34].

The self-discharge rated of 5% per month is significantly lower than the one of NiMH, which is averaged at 30%. The “memory effect” is almost negligible in Li-ion batteries and the recharging is significantly faster than the NiMH type. However, faulty manufacturing may lead to loss of capacity over time instead of self-discharge. Finally, the components of the Li-ion battery are safe since there is no release of lithium metal.

**Table 9 - CO2 emissions according to MPG**

A study by the Swiss Federal Laboratories for Materials Testing and Research (or EMPA) in 2010 showed that at most 15% of the total burden to the environment caused by Li-ion automotive batteries can be attributed to the battery itself. Half of that percentage occurs during the actual manufacturing of the battery. Considering the table and figure above, it is evident that PHEVs are significantly more eco-friendly than gasoline operated vehicles. As far as emissions are concerned, hybrid vehicles are clearly more eco-friendly. As

MPG	CO <sub>2</sub> (g/mile)
38+	0-236
31-37	237-290
27-30	291-334
23-26	335-394
22	395-412
19-21	413-479
17-18	480-538
15-16	539-612
13-14	613-710
0-12	711+

mentioned above, the only considerable burden to the environment occurs during the manufacturing of the batteries.

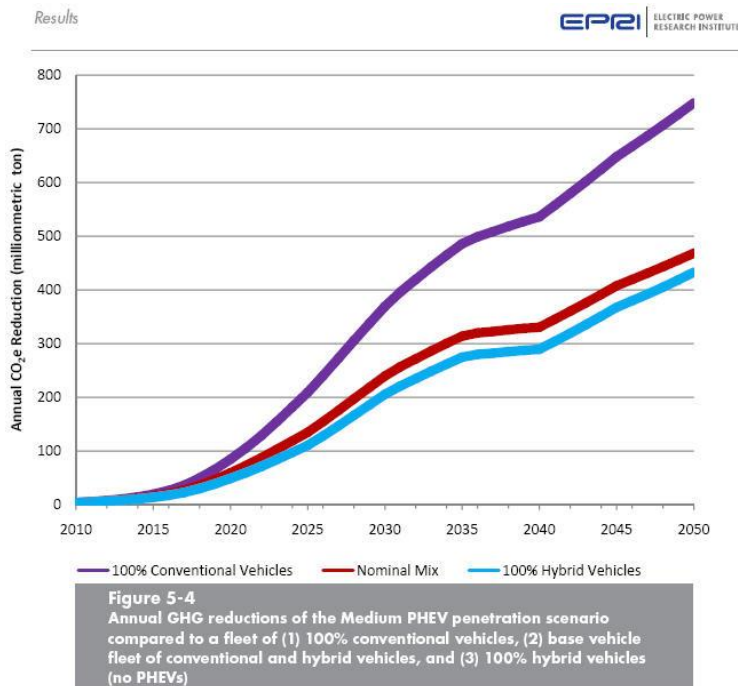

**Figure 64 - Battery Weight v. Driving Range**

### Cost

- 4 times more expensive than NiMH

### Cell life

- Do not last as long in extreme temperatures

### Safety

- Requires protection circuit to avoid cell rupture from overheating

**Figure 65 - Disadvantages of Li-ion Batteries**

Currently, the Li-ion and Li-polymer batteries are significantly more expensive to manufacture than their leading rival, NiMH batteries. However, statistical studies have shown that improvement in energy density and materials have reduced the price of manufacturing. As shown in Figure #, the prices over the last decade have been dropping and the energy density increasing at a good rate [36].

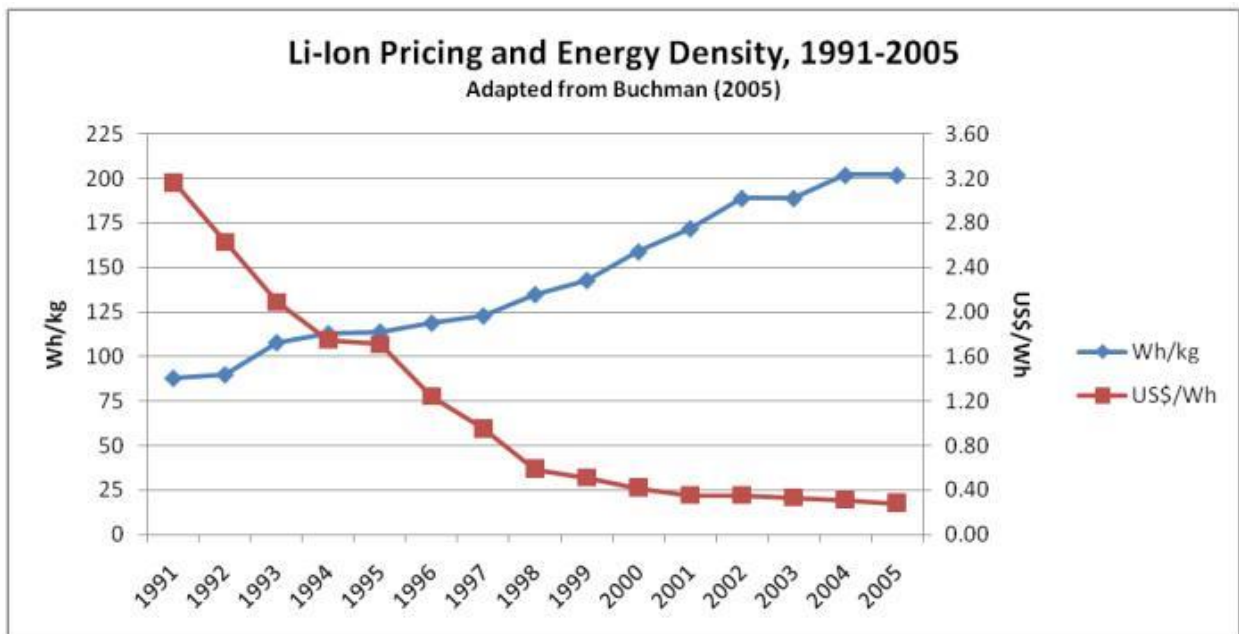

**Figure 66 – Graph of Li-ion battery Pricing compared to Energy Density, 1991-2005**

**Table 10 – Summary of Manufacturing cost components**

Item	High Energy	High Power
Plant capacity (106 cells/y)	2	6
Workers	120	140
Capital investment (\$106)	30	35
Labor cost (\$/cell)	3.5	1.4
Overhead cost (\$/cell)	2.5	0.95
Material cost (\$/cell)	154.63	11.89
Total manufacturing cost (\$/cell)	160.63	14.24
Materials as % of total	96	83

As seen in Table 10 above, the three main components of cell costs are materials, labor and overhead. The material cost is significantly higher, indicating that the drop in price of batteries will come from a drop in price in crude materials such as: cobalt, manganese, lithium and nickel.

**Table 11 - Material Costs for 100-Ah High Energy Cell and a 10-Ah High Power Cell**

Material	Price (\$/kg)	Quantity (g)	Cost/cell (\$)	%	Quantity (g)	Cost/cell (\$)	%
Cathode	15	1,408.6	21.13	35.6	64.8	0.97	17.8
Separator	40	60.5	2.42	4.1	16.4	0.66	12
Electrolyte	30	618	18.54	31.2	44	1.32	24.2
Graphite	12	563.6	6.76	11.4	12.7	0.15	2.8
Can and vent		291	3.2	5.4	70	0.77	14.1
Binder	20	162.6	3.25	5.5	8.8	0.18	3.2
Copper	10	151.9	1.52	2.6	41.6	0.42	7.6
Aluminum	15	63	0.95	1.6	19.4	0.29	5.3
Carbon	12	46.4	0.56	0.9	2.2	0.03	0.5
Other	15	67.1	1.01	1.7	44.8	0.67	12.3
<b>Total</b>		<b>3,432.7</b>	<b>59.33</b>	<b>100</b>	<b>324.7</b>	<b>5.45</b>	<b>100</b>

Table 11 above expands on the material cost of a specific battery. This can also be visualized graphically as seen in Figure 67 below:



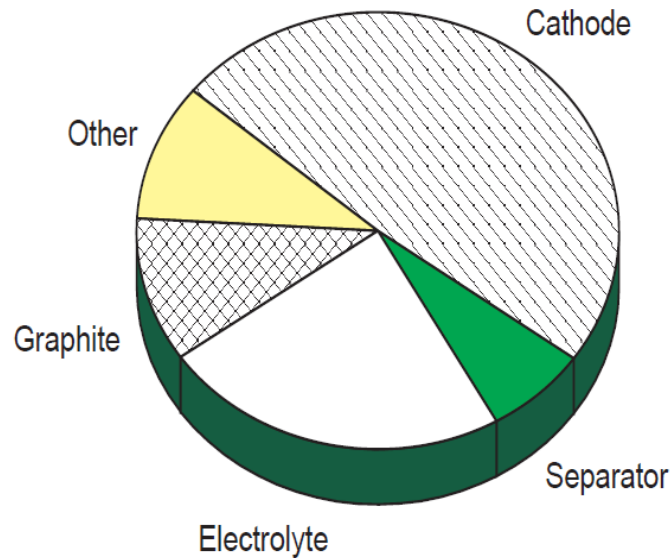

**Figure 67 – Material cost of Li-ion battery cell**

Is obvious that the cathode contributes about half of the total material cost. A fact that justifies the research focused on the development of more efficient materials for the cathode.

**Table 12 – Current Cathode Material Prices**

Base Element	Price, \$/lb (\$/kg)	Cathode Material	Current Price \$/lb (\$/kg)	High-Volume Price, \$/lb (\$/kg)
<b>Cobalt</b>	18 (40)	LiCoO <sub>2</sub>	25 (55)	20 (45)
<b>Nickel</b>	4.42 (9.70)	LiNi <sub>0.8</sub> Co <sub>0.2</sub> O <sub>2</sub>	30 (67)	20-23 (45-50)
<b>Manganese</b>	1.21 (2.67)	LiMn <sub>2</sub> O <sub>4</sub>	27 (59)	7 (15)

Note that these prices are not an indication of which cell type chemistry is more efficient. The various cell types have different energy densities and life cycles. However, these prices do affect the starting price of the PHEV, where Li-Manganese is definitely the cheapest choice. An analysis by McKinsey & Co., predicted that the price for lithium-ion batteries could fall down to around \$200 per kilowatt-hour. This will happen by technical advancements in

cathodes and electrolytes as well as a reduction in the cost of materials as economies of scale drive down the price.

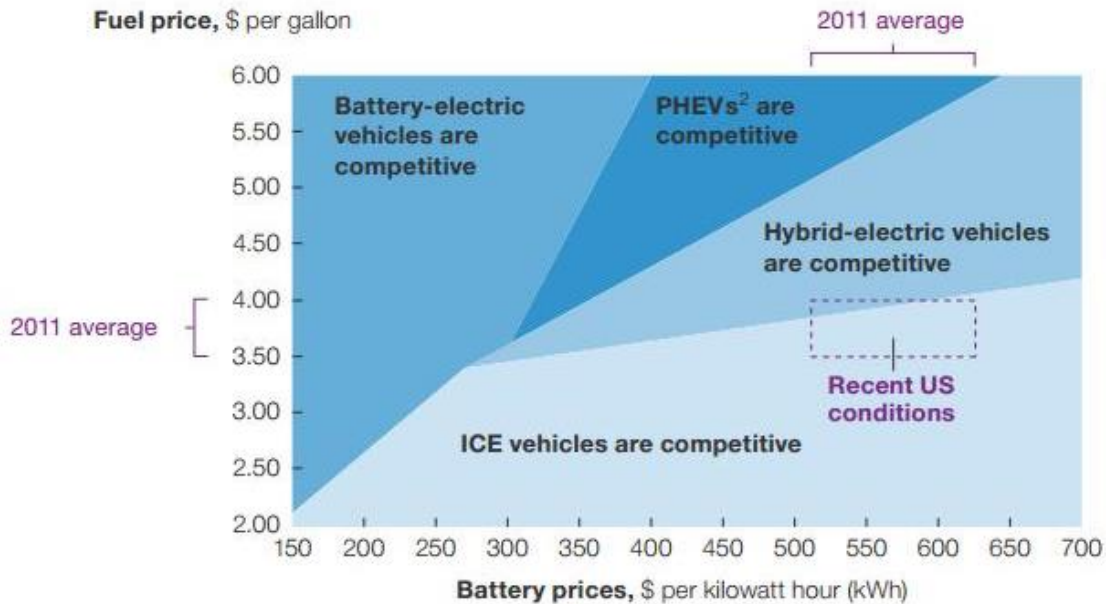

<sup>1</sup>Assumes 240 watt hours per mile (as may be achieved with lightweight, efficient air conditioning) compared with today's 305–322 watt hours per mile.

<sup>2</sup>Plug-in hybrid-electric vehicles.

**Figure 68 – Interaction of battery and fuel costs**

If one considers the aforementioned analysis to be valid and the stability of gas prices, by 2020 battery-electric vehicles will be extremely competitive and will occupy a large portion of the automotive market. One can expect that PHEVs are going to be a competitive product within 5 years [37]. Depending on the materials used for the cell, Li-ion batteries lose their capacity as they age. This is an unavoidable problem due to the chemistry of the battery. However, major improvements have been made, with the latest types such as Li-Titanate promising a cell life of 15 years or 9000 cycles. Below, one can see that after 20000 cycles, a A123 LiFePO<sub>4</sub> still has 65% of its initial capacity [37].

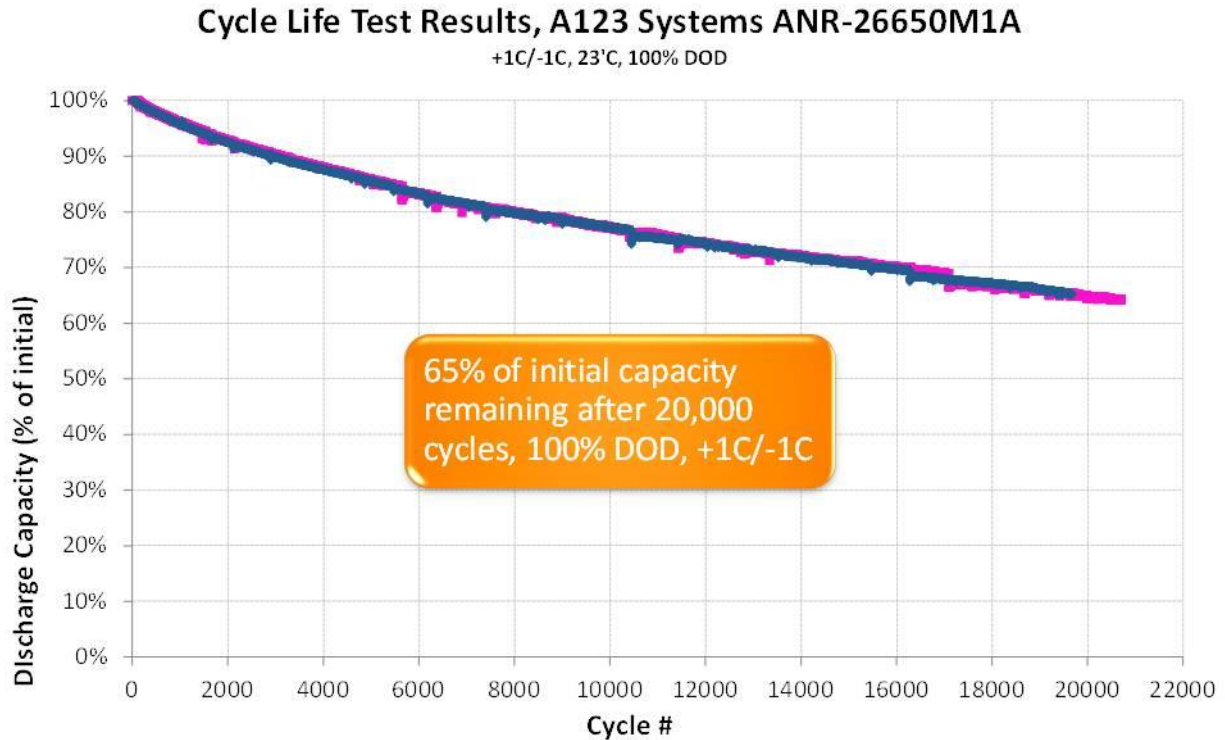

**Figure 69 – Cycle life Test Results at 20000 cycles**

The basic safety concern of Li-ion batteries is overheating which would lead to a collapse of the electrode and result in an explosion. Even though this problem is still relevant, modern types of cells as well as proper voltage regulating circuits have limited the problem significantly. There are a few cases of Li-ion batteries exploding in laboratory conditions after extreme testing.

### **3.2.6 Discussion**

Each of the proposed solutions have pros and cons for ambulance applicability. Taking cost, practicality, effectiveness, and necessity into account, some options are more feasible than others. Many of them are technology-dependent solutions, meaning they may not necessarily be practicable now they may be in the near future.

Although fuel cells have great potential, they are currently not cost effective enough to be implemented into ambulances. The scarce source of hydrogen fuel pumps make fuel cells a difficult option because there are so few places where they can be refilled. Future developments in this technology will continue to reduce cost and increase efficiency, although they are currently not quite there yet.

Solar panels have already been implemented into ambulances, proving that their effectiveness and practicality are well worth the cost. Although they would not be powerful enough to fully sustain the energy requirements for the entire ambulance, they could sufficiently reduce the load on the alternators within the ambulance. When paired with other technologies such as LED lighting and lithium ion batteries, an extremely effective system could be developed where all non-critical components within the ambulance could be powered by the panels while the standard alternator system could be dedicated to the essential life-saving equipment. Additionally, a reduction of gasoline usage through plug-in hybrid technology was proposed; a solution that is both cost-effective and environmentally friendly.

The cost of implementing these new technologies would not be significant when compared to the large amount of energy (thus money) saved in the long run. Therefore an ambulance, which has a large solar panel on the roof, which charges a pack of Li-ion batteries onboard, could supply all of the required power for all interior and exterior lights.

#### **Chapter 4 Concluding Remarks**

As we enter a new age of environmentally-friendly technology, it is important to reduce the burden to the environment, while maximizing efficiency. Implementing the methods of improvement we proposed into medical ambulances will provide numerous

benefits in mobile healthcare and accident survival rates, while reducing carbon emissions and saving energy.

By looking through each specific category of energy consuming devices onboard an ambulance, a complete understanding of the electrical systems involved was developed. These categories were broken down further in order to investigate the purposes of each component and what role they play in mobile medical emergencies. By analyzing the power consumption with regards to importance and applicability in emergency situations, the most vital components were separated from those which are not as critical. Following, suggestions were made on preventing power failure in aspects of operation that are most critical.

After understanding how the production and consumption of the electrical systems function, the development of innovative solutions can be implemented. Using these solutions to increase production and/or reduce consumption, a model for a more efficient and effective ambulance could be established. By researching various options to complete this task, it became clear that some would be more suitable than others. The balance of applicability, ease of implementation, cost, effectiveness, practicality, and necessity had to be considered while deciding which systems would be most appropriate. A comparative study on the power consumption and power production of the ambulance was conducted. The power output was researched and presented with detail, allowing suggestions to be made to the distribution of power. The typical ambulance power system was termed obsolete, and archaic, considering the numerous alternative options available. .

A further research on the improvement of those methods is needed. Emerging technologies, such as Li-ion batteries and fuel cells are predicted to flood the automotive industry, changing the standards of emergency vehicles. Additionally, an improvement of the

efficiency of the most critical components of an ambulance is required. As a final point, the mechanical and dynamic aspects of the ambulance were overlooked in search for efficient solutions. A study of these mechanical aspects and implementation in the CAD model would be ideal.

Numerous limitations and obstacles were faced in the development of the project. The variety of physical attributes and equipment in various ambulances poses a difficulty in generalizing and proposing a common solution. An attempt was made to cover most ambulance models; however, emphasis was placed on improving the specific GMC 3500 model. The standards that are currently in effect, severely limited the selection of aspects of improvement, as they had to fall within the federal and state specifications. In addition, safety issues of the proposed solutions had to be considered; as a result, some methods of improvement were rejected. Finally, a more practical, cost - effective approach was preferred, which resulted in certain high cost solutions being excluded.

## References

- [1] Federal Specification for the Star-of-Life Ambulance, KKK-A-1822F, U.S. General Services Administration, July 1, 2007
- [2] Garland, Nancy. "DOE Hydrogen and Fuel Cells Program Home Page." *DOE Hydrogen and Fuel Cells Program Home Page*. December 19, 2008., 2012. Web. 15 Mar. 2013.
- [3] "Fuel Cells 2000." *Fuel Cells & Hydrogen*. N.p., 2013. Web. 11 May 2013.
- [4] "Hydrogen Fuel." *Energy Basics*:. N.p., 28 Feb. 2013. Web. 01 Apr. 2013.
- [5] Nice, Karim, and Jonathan Strickland. "How Fuel Cells Work." *HowStuffWorks*. N.p., n.d. Web. 09 May 2013.
- [6] "Fuel Cell Vehicles." *Fuel Cell Vehicles*. US Department of Energy, n.d. Web. 09 Mar. 2013.
- [7] "How Fuel Cells Work." *Home*. Fuel Cell and Hydrogen Energy Association, 2012. Web. 05 Mar. 2013.
- [8] "Basic Research Needs for the Hydrogen Economy." Office of Science, Department of Energy.<<http://www.sc.doe.gov/bes/hydrogen.pdf>>
- [9] Goho, Alexandra. "Micropower Heats Up: Propane fuel cell packs a lot of punch." McGraw-Hill Encyclopedia of Science and Technology.
- [10] Goho, Alexandra. "Special Treatment: Fuel cell draws energy from waste." McGraw-Hill Encyclopedia of Science and Technology.
- [11] "Hydrogen Posture Plan." United States Department of Energy. <[http://www1.eere.energy.gov/hydrogenandfuelcells/pdfs/hydrogen\\_posture\\_plan.pdf](http://www1.eere.energy.gov/hydrogenandfuelcells/pdfs/hydrogen_posture_plan.pdf)>
- [12] Rose, Robert. "Questions and Answers about Hydrogen and Fuel Cells." Breakthrough Technologies Institute.<http://www.fuelcells.org>
- [13] Berg, Linda R., and Mary Catherine. Hager. *Visualizing Environmental Science*. Hoboken, NJ: Wiley in Collaboration with the National Geographic Society, 2007. Print.
- [14] "Destination of Marvel." *Earth Science/Social Human Science/Earth's History and Evolution/ Earth Yesterday Today and Tomorrow-Climate/climate Change*. N.p., n.d. Web. 15 Mar. 2013.
- [15] "Disadvantages Of Solar Energy." *Disadvantages Of Solar Energy*. N.p., n.d. Web. 15 Mar. 2013.

- [16] "Homemade Solar Panels." *Homemade Solar Panels*. N.p., n.d. Web. 15 Mar. 2013.
- [17] "Photovoltaic Module | Photovoltaic Array Software | Solar Panel Software | Wind Solar Energy Software | ETAP." *Photovoltaic Module / Photovoltaic Array Software / Solar Panel Software / Wind Solar Energy Software / ETAP*. N.p., n.d. Web. 10 ar. 2013.
- [18] "PhotovoltaicAbout Our Definitions: All Forms of a Word (noun, Verb, Etc.) Are Now Displayed on One Page." *Merriam-Webster*. Merriam-Webster, n.d. Web. 10 ar. 2013.
- [19] "The Solar Blog - Get the Latest News on Solar Energy." *The Solar Company*. N.p., n.d. Web. 10 ar. 2013.
- [20] "Southwest Ambulance Adds Solar Panels in Fleet." *JEMS.com*. N.p., n.d. Web. 15 Mar. 2013.
- [21] "Sunstar Ambulances Tap the Sun to Tack on Power." *Tampa Bay Times*. N.p., n.d. Web. 15 Mar. 2013.
- [22] "U.S. Solar Power Market Boomed in 2011." *Planet Impact Inc*. N.p., n.d. Web. 10 ar. 2013.
- [23] Wang, Uculia. "A Debate Emerges: Are Solar Panels a Commodity Yet? — Tech News and Analysis." *GigaOM A Debate Emerges Are Solar Panels a Commodity Yet Comments*. N.p., n.d. Web. 09 Feb. 2013.
- [24] "The 2008 FCX Clarity." *Honda FCX Clarity Overview*. Web. 19 March 2012.
- [25] Niccum, Ann. "Conversion to LED Lighting Continues." *The Edwardsville Intelligencer*. N.p., 13 Aug. 2008. Web. 19 March 2012..
- [26] Navigant Consulting, Inc. *Life-Cycle Assessment of Energy and Environmental Impacts of LED Lighting Products*. Rep. DOE, Aug. 2012. Web. Apr. 2013.
- [27] Gazzara, Justin. "Automotive LED Lighting Explained." *CariD*. 19 March 2012. <<http://www.carid.com/articles/automotive-led-lighting-explained.html>>
- [28] LEDs Are Making Inroads on Automotive Lighting Systems. Power Electronics Technology (Online Exclusive). (June 26, 2012)
- [29] Whelen Engineering Company, Inc. Est. 1952.
- [30] *History of Wind Energy* in Cutler J. Cleveland,(ed) *Encyclopedia of Energy Vol.6*, Elsevier, [ISBN 978-1-60119-433-6](https://doi.org/10.1016/B978-1-60119-433-6), 2007, pp. 421-422



- [31] "FAQs | NJ OCE Web Site." *FAQs / NJ OCE Web Site*. N.p., n.d. Web. 09 Apr. 2013. <<http://www.njcleanenergy.com/renewable-energy/technologies/wind/faqs>>.
- [32] "Alternative Energy." *AENews*. N.p., n.d. Web. 09 Apr. 2013. <<http://www.alternative-energy-news.info/running-a-car-on-wind-energy/>>.
- [33] "Wind-Powered 'Ventomobile' Places First in Race." *ScienceDaily*. ScienceDaily, 28 Aug. 2008. Web. 10 Mar. 2013.
- [34] Buchmann, Isidor. "Is lithium-ion the ideal battery?" Battery University. Updated November 2006. (June 26, 2008) <http://www.batteryuniversity.com/partone-5.htm>
- [35] Bullis, Kevin. "The Lithium-Ion Car." *Technology Review*. MIT. March 24, 2006. (June 26, 2008) <http://www.technologyreview.com/Biztech/16624/page1/>
- [36] Hall, Kevin G. "High Oil Prices Fuel Development of New Hybrid Batteries." *McClatchy Newspapers*. June 8, 2008. (June 26, 2008) <http://www.mcclatchydc.com/226/story/39869.html>
- [37] MSNBC Staff. "Breakthrough battery for electric cars?" MSNBC. Dec. 13, 2007. (June 26, 2008) <http://www.msnbc.msn.com/id/22240865/>

**Appendix A**  
**AMD STANDARD 005**

**AMBULANCE 12 VOLT DC ELECTRICAL SYSTEM**

S1. SCOPE. This standard establishes performance requirements for ambulance electrical systems.

S2. PURPOSE. The purpose of this standard is to establish testing and certification procedures for

ambulance 12 volt DC electrical system and to set performance criteria.

S3. DEFINITION.

S3.1 “Common Point” Means a point in the ambulance 12-volt DC electrical system that is common

for the electrical generating and storage system to the electrical consuming system of the vehicle,

at which the current is to be measured.

S4. REQUIREMENTS. Each ambulance shall be tested.

S4.1 The following systems (loads) shall be simultaneously turned on during the process of the test:

1. Ignition system
2. Headlights (low beam) and all FMVSS running lights
- 3 Windshield wipers (low speed)
4. Cab air conditioning (at coldest setting with highest blower speed)
5. Radio in receiving mode (or 5 amp load, if not equipped)
6. Patient module dome lighting (in high intensity setting)
7. Patient module air conditioning (at coldest setting with highest blower speed)
8. Emergency warning light system in “clear-right-of-way” mode (3.8.2)
9. 10 amp medical load or equal
10. Left and right side flood lights

11.Rear flood light

(12) Optional 12-volt DC equipment and lights.

NOTE: ALL ABOVE LOADS MUST NOT BE DEACTIVATED IF THE VEHICLE IS EQUIPPED WITH A LOAD MANAGEMENT SYSTEM.

S4.2 The generating system(s) shall produce the maximum required output at the regulated voltage,

and minimum under hood temperature of 200 degrees Fahrenheit, at an engine speed not exceeding

40% of the furnished engine's SAE net horsepower @ rpm rating or in accordance with chassis manufacturer's operating instructions.

S4.3 A certification label containing the information in S7.2 shall be affixed to the ambulance, certifying

that the vehicle has been tested and is certified as capable of supporting the mandatory continuous current load as manufactured in accordance with S4.1.

#### S5. TEST PROCEDURES.

S5.1 A direct current (DC) ampere meter, capable of measuring the worst case continuous current,

with an accuracy of not less than 2% of full-scale reading, shall be inserted into the common point of the ambulance electrical system along with a DC-voltmeter, capable of reading the voltage specified in S5.2 with an accuracy of plus or minus 2%.

S5.2 The engine will be started and set to the necessary revolutions per minute (rpm) in compliance

with S4.2 to maintain the system voltage between 12.8 and 14.2 volts for the duration of the test.

#### **REV. 10-98**

S5.3 Immediately following warm-up, all systems and load(s) listed in S4.1 (1) through (11) will be

turned on. If the ambulance is equipped with a load management system that inhibits certain

systems and loads from operating under certain conditions, ambulance shall be put into the condition that will allow the maximum electrical load.

S5.4 The test shall be run for a full 15 minutes and the voltages shall remain within the limits specified

in S5.2.

S5.5 At both the beginning and end of the 15-minute test period a reading as specified in S5.1 will be

taken as required by S4.

S5.6 Immediately following warm-up, all systems and load(s) listed in S4.1 (1) through (12) will be

turned on. If the ambulance is equipped with a load management system that inhibits certain systems and loads from operating under certain conditions, items 1 through 12 shall not be deactivated that will allow the maximum electrical load.

S5.7 The test shall be run for a full 15 minutes and the voltages shall remain within the limits specified

in S5.2.

S5.8 At both the beginning and end of the 15 minute test period a reading as specified in S5.1 will be

taken as required by S4.

S6. TEST CONDITIONS. The following conditions apply to the requirements specified in S5.

S6.1 Ambulance and component systems shall be complete and ready to operate on the road.

S6.2 Temperature. Engine shall be started and allowed to operate until normal engine temperature is

reached then allowed to operate an additional 15 minutes.

S6.3 Batteries. Batteries shall be fully charged.

S6.4 The engine speed indicated for S4.2 shall be determined with a tachometer accurate within plus

or minus 3%.

## S7. CERTIFICATION.

S7.1 The lowest reading recorded in S5.5 and S5.8 shall be recorded on the certification tag (7.2) and

attached to the ambulance for easy inspection, attesting to the worst case continuous current for

the specific ambulance being tested.

### **AMD STANDARD 005 . Page 2**

#### **REV. 10-98**

S7.2 Certification label. The following data and statement shall appear on the certification label:

This vehicle has been tested in accordance with Ambulance Electrical Systems, AMD Standard 005.

a. The data furnished herein is based upon simultaneously turning on the following electrical equipment and electrical load(s).

- (1) Ignition system
- (2) Headlights (low beam) and all FMVSS running lights
- (3) Windshield wipers (low speed)
- (4) Cab air conditioning (at coldest setting with highest blower speed)
- (5) Radio in receiving mode (or equal load, if not equipped)
- (6) Patient module dome lighting (in high intensity setting)
- (7) Patient module air conditioning (at coldest setting with highest blower speed)
- (8) Emergency warning lighting system in “clear-right-of-way” mode (3.8.2)
- (9) 10 amp medical load or equal
- (10) Left and right side flood lights
- (11) Rear flood light
- (12) Optional 12-volt DC equipment and lights.

## **Appendix B**

### **AMD STANDARD 009**

#### **120V AC ELECTRICAL SYSTEMS**

S1. SCOPE. The provisions of this standard cover the electrical conductors and equipment installed

within or on ambulances and the conductors that connect ambulances to 120 or 120/240 volt, nominal, AC electrical supply system(s).

S2. OTHER ARTICLES. Whenever the requirements of National Electrical Code (NEC) and this

standard differ, the requirements of this standard shall apply.

S3. DEFINITIONS.

S3.1 “Inverter” means a device that changes energy from one form to another as from direct current

to alternating current.

S3.2 “Converter” means a device that changes electrical energy from one form to another as from

alternating current to direct current.

S3.3 “Low Voltage” means an electromotive force rated 24 volt, nominal, or less, supplied from a

transformer, converter or battery.

S4. 120-VOLT AC NOMINAL SYSTEMS:

a. General Requirements. The electrical equipment and material indicated for connection to a wiring system rated 120 volts, nominal, 2-wire with ground, shall be listed and installed in accordance with the requirements of this document. No ungrounded systems shall be used.

b. Materials and Equipment. Electrical materials, devices, appliances, fittings and other equipment

installed, intended for use in, or attached to the ambulance shall be listed or recognized.

All products shall be used only in the manner for which they were tested and found suitable.

c. Other Sources. Other sources of AC power shall be wired in full conformity with the requirements

of this standard.

d. On-Board 120V AC Power Restriction. Transfer equipment, if not integral with the listed power source, shall be installed to ensure that the current carrying conductors from the on board 120-volt AC power source and from the 120-volt AC utility power source are not connected to ambulance electrical circuit at the same time.

e. Grounding. Grounding shall be in accordance with section 250-6 [Portable and Vehicle Mounted Generators] of the National Electrical Code (NEC).

f. Ground Fault Protection for Personnel. All 120-volt AC receptacle outlets of the ambulance shall have ground fault circuit interrupter protection.

#### S5. 120-VOLT AC UTILITY POWER.

a. Connecting To Utility Power. The ambulance shall include a means for connecting the 120-volt AC electrical system to an external utility power.

b. Utility Power Cable Assembly. The power supply cable assembly may be manufacturer supplied. Unless specified by purchaser, the power supply cable assembly shall have a cord length of 25 feet (minimum) and include a weatherproof female connector body and weatherproof

attachment plug.

c. Utility Power Body Connector. The ambulance shall be equipped with a permanently mounted, flanged, weatherproof surface inlet (male recessed type receptacle) wired directly to the distribution panel board by an approved wiring method. The attachment plug and body connector shall be of a listed type.

#### **REV. 10-98**

(1) Ambulances having only one 15-ampere branch circuit shall have an attachment connector

body which shall be two-pole, three-wire grounding type, rated 15 amperes, 125 volts, conforming to the configurations in American National Standards Institute (ANSI) Standard C73.17.1972 or approved NEMA connector for the amperage of the service provided.

(2) Ambulances having two 15 or 20-ampere branch circuits shall have an attachment connector

body which shall be two-pole, three-wire grounding type, rated 30 amperes, 125 volts, conforming to the configurations in ANSI Standard C73.17.1972 or approved NEMA connector for the amperage of the service provided.

(3) Ambulances may be equipped with two separate 15-ampere or 20-ampere circuits each having an attachment body connector that has receptacles rated for the same amperage and voltage as the circuit breakers.

d. Labeling at Electrical Entrance. Each ambulance shall have permanently affixed to the exterior

skin at or near the point of entry of the power supply cord(s): “This connection is for 120V AC, 60 Hz, [ ] ampere supply.” The correct ampere rating shall be marked in the blank space. The point of entrance of a power supply assembly shall be specified by the purchaser.

e. Power Supply Grounding. The grounding conductor in the supply cord or feeder shall be connected to the grounding bus or other approved grounding means on the distribution panel board.

#### S6 DISTRIBUTION BOX

a. Dead-Front Type. The distribution box shall be of the dead-front type and shall consist of an

appropriately sized cutout enclosure, one or more circuit breakers or ground fault circuit interrupters and a distribution panel board.

b. Location. The distribution box shall be installed in a readily accessible location.

c. Distribution Panel Board. The distribution panel board shall have a grounding bus with



sufficient terminals for all chassis grounding and separate neutral grounding conductors or other approved grounding means.

d. Insulated Neutral. The grounded circuit conductor (neutral) shall be insulated from the equipment grounding conductors and from equipment enclosures and other grounded parts. The grounded (neutral) circuit terminals in the distribution panel board and in appliances shall be insulated from the equipment enclosure. Bonding screws, straps, or buses in the distribution panel board or on appliances shall be removed.

#### S7. GENERAL WIRING METHODS

a. Wiring Systems. 120-volt AC electrical system shall be limited to the following methods:

(1) Rigid metal conduit, intermediate metal conduit, Type SO cord (600 V and 90 degrees Celsius minimum) covered in 300-degree Fahrenheit minimum flame retardant loom of moisture resistant type, electrical metallic tubing, rigid non-metallic conduit, flexible metal conduit, flexible non-metallic conduit, or liquid tight flexible conduit.

(2) Only stranded copper conductors shall be used.

(3) An equipment grounding means shall be provided in accordance with Section 250-91 [Grounding Conductor Material] of the NEC.

(4) Where rigid metal conduit or intermediate metal conduit is terminated at an enclosure with a lock-nut and bushing connection; two lock-nuts shall be provided, one inside and one outside of the enclosure. All cut ends of conduit shall be reamed or otherwise finished to remove rough edges.

b. Non-Metallic Boxes. Non-metallic boxes shall be acceptable only with non-metallic conduit.

#### **AMD STANDARD 009 . Page 2**

#### **REV. 10-98**

c. Mounting. Boxes shall be mounted in accordance with Article 370 [OUTLET, DEVICE, PULL

AND JUNCTION BOXES, CONDUIT BODIES AND FITTINGS] of the NEC.

d. Bends. No bend shall have a radius of less than five times the cable or conduit diameter, whichever is greater.

e. Cable Supports. When connected with cable connectors or clamps, tubing conduit, and loom

shall be supported within 12 inches of outlet boxes, distribution panel boards and splice boxes on appliances. Supports shall be provided every 4.5 feet (1.37 meters) at other places.

f. Physical Damage. Where subject to physical damage, exposed type SO cable may be protected

by guard strips, raceways or other means.

g. Branch Circuits. Each ambulance containing a high-voltage electrical system shall contain one of the following:

(1) One 15-Ampere Circuit. One 15-ampere circuit to supply receptacle outlets and fixed appliances. Such ambulance shall be equipped with one 15-ampere switch and fuse or 15-ampere circuit breaker. All circuits shall be GFI protected.

(2) Two 15 or 20-Ampere Circuits. Two 15 or 20-ampere circuits to supply receptacle outlets and fixed appliances. Such ambulances shall be equipped with a 30-ampere minimum rated main power supply assembly. See Section 210-23(a) [Permissible Loads] of the NEC for permissible loads. All circuits shall be GFI protected.

h. Branch Circuit Protection. The branch circuit over current devices shall be rated:

(1) Not more than the circuit conductors and

(2) Not more than 150% of the rating of a single appliance rated 13.3 amperes or more and supplied by an individual branch circuit, or according to the appliance manufacturer, but

(3) Not more than the over current protection size marked on motor-operated appliances.

## S8. ON-BOARD GENERATOR/INVERTER POWER SUPPLY

a. Separate Over Current Protection. When an onboard 120-volt AC power source is installed,

the output from that power source shall be protected by an over current protective device.

b. Multiple Power Source Transfer Switch. Where a multiple supply system consisting of an alternate power source and a utility power supply are installed, a means for automatically or manually selecting the power source shall be provided. Equipment shall be installed to ensure that the current-carrying conductors from the onboard power source and from the utility power source are not connected to an ambulance 120-volt AC electrical circuit at the same time.

c Mounting. On-board inverters/generators shall be mounted in such a manner as to be effectively

bonded to the ambulance chassis and in accordance with the instructions provided by the manufacturer of the on-board generator set or inverter.

d. Supply Conductors. The supply conductors from the on-board power source to the first termination on, or in, the ambulance shall be of the copper-stranded type. The point of first termination shall be (1) a transfer switch, (2) a junction box with a blank cover, (3) a junction box with a receptacle, or (4) a receptacle assembly listed in conjunction with the on-board generator/inverter. (5) a Panel Board.

e. Transfer Switch Location. When required, the transfer switch may be mounted on the distribution

panel, in a separate junction box or be an integral part of the generator/inverter. A

receptacle assembly listed in conjunction with the on-board generator/inverter shall be mounted in accordance with its listing.

f. Additional Generator Requirements. Section 445 [GENERATORS] of the NEC shall be complied

with.

**AMD STANDARD 009 . Page 3**

**REV. 10-98**

S9. SWITCHES. Switches shall be listed and rated as follows:

a. Lighting Circuits. For lighting circuits, switches shall be rated not less than 10 amperes, 120-

125 volts and in no case, less than the connected load.

b. Motors or other loads. For motors or other loads, switches shall have ampere or horsepower ratings, or both, adequate for loads controlled. (An AC general use snap switch shall be permitted to control a motor 2 HP or less with full load current not over 80% of the switch ampere rating.)

c. Marking. All switches shall be labeled with their function.

#### S10. RECEPTACLES

a. All exterior receptacle outlets shall be weatherproof and be grounding type and installed in accordance with Section 210-7 [Receptacles and Cord Conductors] of the NEC. See the ANSI Standard # C73.17.1972 for proper configurations.

b. All interior outlets shall be of the lighted grounding type installed in accordance with Section

210-7 (Receptacles and Cord Conductors) of the NEC.

c. Face-up Position Restriction. No receptacle shall be installed in a face-up position.

#### S11 INTERIOR EQUIPMENT GROUNDING

a. Exposed Metal Parts. In the electrical system, all exposed metal parts, enclosures, frames, fixtures, canopies, etc., shall be effectively bonded to the grounding terminals or enclosure of the distribution panel board.

b. Equipment Grounding Conductors. Only bare wires, green colored, or green wires with yellow stripes shall be used for equipment grounding conductors.

c. Grounding of Electrical Equipment. Grounding of electrical equipment shall be provided as follows:

(1) Connection of metal raceway, i.e., conduit or electrical metallic tubing.

(2) A connection between the one or more equipment grounding conductor and a metal box by means of a grounding screw (which shall be used for no other purpose) or a listed grounding device.

(3) The equipment grounding conductor shall be permitted to be secured under a screw threaded into the fixture canopy other than a mounting screw or cover screw or attached to a listed grounding means (plate) in a non-metallic outlet box for fixture mounting (grounding means shall also be permitted for fixture attachment screws).

d. Grounding Connection in a Non-metallic Box. A connection between the one or more equipment

grounding conductors brought into a non-metallic outlet box shall be so arranged that a connection can be made to any fitting or device in that box which requires grounding.

e. Grounding Continuity. Where more than one equipment grounding conductor or branch circuit enters a box, all such conductors shall be in good electrical contact with each other and the arrangement shall be such that the disconnection or removal of a receptacle, fixture, or other device fed from the box will not interfere with or interrupt the grounding continuity.

f. Cord-Connected Appliances. Cord-connected appliances shall be grounded by means of an approved cord with equipment grounding conductor and grounding attachment plug.

## S12. BONDING OF NON-CURRENT-CARRYING METAL PARTS

a. Required Bonding. All exposed non-current carrying metal parts that may become energized

shall be effectively bonded to the grounding terminal or enclosure of the distribution panel board.

**AMD STANDARD 009 . Page 4**

**REV. 10-98**

b. Bonding Chassis. A bonding conductor shall be connected between the distribution panel board and an accessible terminal on the chassis. Aluminum or coppered aluminum conductors

SHALL NOT be used. Any ambulance that employs a unitized metal chassis-frame construction to which the distribution panel is securely fastened with a bolt and nut shall be considered to be bonded.

c. Bonding Conductor Requirements. Grounding terminals may be of the solderless type and listed as pressure terminal connectors recognized for the wire size used. The bonding conductor

shall be copper strand and equal in amperage capacity to the main supply cables.

d. Metallic Body and Exterior Bonding. The ambulance body and exterior covering shall be considered bonded where:

(1) The metal panels overlap one another and are securely attached to the metal frame parts by metal fasteners or welding and

(2) The lower panel of the metal exterior covering is secured by metal fasteners at each cross member of the chassis, or the lower panel is bonded to the chassis by a metal strap.

e. Metal Air Duct. Metal circulating air ducts shall be bonded.

f. Compressed Gas Pipe Bonding. The compressed gas pipes shall be considered bonded if they

are bonded to the chassis.

**S13. APPLIANCE ACCESSIBILITY AND FASTENING.** All electrical appliances shall be accessible for

inspection, service, repair and replacement without removal of permanent construction. Means

shall be provided to securely fasten appliances in place.

**S14. FACTORY ELECTRICAL TESTS.** Each ambulance shall be subjected to the following tests:

a. Dielectric Breakdown Test. The 120-Volt AC electrical system shall withstand the applied potential without breakdown of a 1-minute 900-volt dielectric strength test with all switches closed, between current-carrying conductors including neutral and vehicle ground.

- b. Continuity Test. A continuity test is to be performed to ensure that all metallic parts are properly bonded.
- c. Operational Test. Operational tests are to be performed to demonstrate that all equipment is properly connected and in working order.
- d. Polarity Test. A polarity test is to be performed to ensure that all electrical connections have been properly made.

## **Appendix C**

Federal Specification for the Star-of-Life Ambulance, KKK-A-1822E

### **3.7 ELECTRICAL SYSTEM AND COMPONENTS.**

#### **3.7.1 ELECTRICAL SYSTEM (REFERENCE FIGURE 5A or 5B).**

The ambulance electrical system shall be equipped with, but not limited to, the following: dual, chassis manufacturer's 12 volt batteries; generating, starting, lighting, visual and audible warning systems; specified electronics equipment and devices (including master consoles located in the cab and patient compartment); and other specified accessory wiring. The electrical systems and equipment shall comply with all applicable FMVSS, Federal Motor Carrier Safety Regulations (FMCSR), and shall also conform to all the applicable SAE recommended standards and practices, whether or not specifically referenced in this document, while complying with the subparagraphs herein. ALL ELECTRICAL AND ELECTRONIC COMPONENTS SHALL BE SELECTED TO MINIMIZE ELECTRICAL LOADS THEREBY NOT EXCEEDING THE VEHICLE'S GENERATING SYSTEM CAPACITY. All electrical system components and wiring shall be readily accessible through access panels for checking and maintenance. All switches, indicators, and controls shall be located and installed in a manner that facilitates easy removal and servicing. All exterior housings of lamps, switches, electronic devices, connectors, and fixtures shall be corrosion resistant and weatherproofed.

Electrical fixtures attached to the sides of the ambulance below the 191 cm (75 in.) level shall be near flush mounted and not protrude more than 51 mm (2 in.), except for such items as spotlights and ventilators. All electrical devices and equipment installed, including the electromagnetic coils of high current solenoids, and relays etc, which produce RFI, shall include filters, suppressers, or shielding to prevent electromagnetic radiation and the resultant interference to radios and other electronic equipment (see 3.7.12). Vehicles equipped with electronic engine controls shall be immune from interference caused by radio transmissions.



**WARNING: ELECTRICAL LOADS SHALL BE MINIMIZED. ADDITIONAL ELECTRICAL LOADS ABOVE THOSE REQUIRED BY THIS SPECIFICATION SHOULD BE AVOIDED BECAUSE HEAVY LOADS CAUSE ALTERNATOR AND BATTERY FAILURES. FAILURE OF THESE COMPONENTS WILL LIKELY RESULT IN THE AMBULANCE NOT BEING ABLE TO COMPLETE ITS MISSION.**

The electrical system shall include patient compartment outlets for 12 volt power (see 3.7.7.3) for medical equipment. A driver compartment console-mounted “module disconnect switch or device” (see 3.7.7.4) shall be provided which controls the equipment as defined in Figure 5, page 87.

#### **3.7.1.1 WARNING INDICATORS.**

The electrical system shall incorporate a warning light panel located in the driver’s compartment. It shall provide indicator lights for showing: open patient compartment entry door(s) (see 3.10.8); open equipment compartment door(s); and when batteries are turned on by the battery disconnect switch (when furnished) (see 3.7.7). The “Door Open” warning lights shall be red, flash, and approximately 13 mm (1/2 in.) in diameter, or equal, in area. The battery indicator light shall be green with a lens approximately 13 mm (1/2 in.) in diameter, or equal, in area. Electronic displays that are visible in all ambient light, that projects narrative information may be used in lieu of discrete, colored, indicator/ warning lights provided the projected message is at least as visible as the basic required warning light and complies with FMVSS 101 for displays.. The use of “high intensity” LEDs in lieu of the 13 mm warning light is acceptable. Warning indicators shall be identified and marked per 3.7.11.

### **3.7.2 WIRING INSTALLATION.**

The ambulance body and accessory electrical equipment shall be served by circuit(s) separate and distinct from vehicle chassis circuits. All wiring provided by the ambulance manufacturer shall be copper and conform to all the SAE J1292 requirements and shall have type SXL or GXL high temperature cross linked polyethylene, or better, insulation conforming to SAE J1127 and J1128. The use of multi conductor or ribbon cables are permitted provided they are not exposed to under hood or under vehicle temperatures/conditions. The wiring shall be permanently color coded or marked the entire length of the wire for identification with easily read numbers and/or letters and routed in conduit or high temperature looms with a rating of 149° C (300° F). When cables are supplied by a component manufacturer to interconnect system components, these cables need not be continuously color coded/identified. They shall be coded/identified at the termination or interconnection points. All added wiring shall be located in accessible, enclosed, protected locations and kept at least 15 cm (6 in.) away from exhaust system components. Electrical wiring and components shall not terminate in the oxygen storage compartment except for the oxygen controlled solenoid, compartment light, and switch plunger or trigger device. Wiring necessarily passing through an oxygen compartment shall be protected from damage (see 3.11.3). All conduits, looms, and wiring shall be secured to the body or frame with insulated metal cable straps in order to prevent sagging and movement which results in chafing, pinching, snagging, or any other damage. All apertures on the vehicle shall be properly grommeted for passing wiring and conform to SAE 1292. All items used for protecting or securing the wiring shall be appropriate for the specific application and be standard automotive, aircraft, marine, or electronic hardware. Cable ties shall not be used to support harnesses, but may be used for bundling purposes. Electrical panels that are accessible to accidental contact shall have a

protective cover, shield, etc. to prevent shorts that can result in injury, fire, or damage to the electrical system.

### **3.7.2.1 WIRING CRITERIA.**

All wiring (including grounds), devices, switches, outlets, etc., except circuit breakers, shall be rated to carry at least 125 percent of the maximum ampere load for which the circuit is protected. All terminals shall be permanently numbered or coded. Terminal strip(s), block(s), or multi-pin connector(s) shall be readily accessible for checking and service. All exterior

10 A - 16 GA

15 A - 14 GA

20 A - 12 GA

30 A - 10 GA

40 A - 8 GA

50 A - 6 GA

75 A - 4 GA

100 A - 2 GA

125 A - 0 GA

150 A - 00 GA

wiring to lights or any other component shall utilize sealed connectors or splices.

The ambulance electrical system shall incorporate a master circuit breaker panel with circuit breakers or other electronic, non-disposable, current protection devices, in each circuit, which comply with

SAE J553 Type I, or Type III (if circuit breaker is readily accessible for resetting by the driver or EMT). When multiconductor cables/ribbon cables are used for low current (self limiting) circuits, additional fuses/circuit breakers are not required. Additionally, one 15 ampere circuit breaker shall be provided for future use. For high current circuits, where SAE Type I breakers are not commercially produced, protection for these circuits may be provided with other types of circuit breakers. All circuit breakers shall be securely mounted, easily removable, and readily accessible for inspection and service. All electrical and electronic components, switches,

connectors, circuit breakers, lamps, and indicators, including the vehicle batteries, shall be marked with an easily read identification code number and/or letter. Complete, highly legible, wiring diagrams and schematics, including identification codes and parts list for the ambulance's standard and optional equipment furnished, shall be included in the service manual and be supplied with each ambulance in accordance with paragraph 6.8

#### **3.7.2.2 PRINTED CIRCUITS.**

When printed circuits are utilized, they shall conform to SAE J771. Printed circuit boards shall be securely mounted and protected from physical damage and accidental shorts. Printed circuit board connections and components shall conform to all other specification requirements.

#### **3.7.3 GROUNDING.**

A. Dedicated grounds for all appliances, circuits, etc. shall be furnished. The use of appliance mounting screws/hardware shall not be used for grounding purposes unless specifically designed for such use by the appliance manufacturer.

B. To provide RF grounding and minimize potential interference with chassis manufacturer's computers, the module and chassis cab shall be connected to the chassis frame with a separate dedicated minimum 19 mm (3/4"), braided ground strap with soldered ends that are secured to cleaned metal surfaces on the body and frame with star washers, etc. To prevent corrosion, both ends of the attached ground strap shall then be sealed with either rustproofing compounds or non-hardening battery terminal sealer. (Note: Regular stranded copper wire, while providing a DC ground, does not provide RF grounding.)

#### **3.7.4 WINDSHIELD WIPERS AND WASHERS.**

Vehicle shall be equipped with dual, electric, multi-speed, windshield wipers and washer complying with FMVSS 104. When specified (see 6.2-p), the OEM intermittent wipers shall be furnished.

#### **3.7.5 HORNS.**

The chassis manufacturer's dual electric horns shall be furnished. (see siren section for switching arrangements, (3.14.6)).

**3.7.6 ELECTRICAL GENERATING SYSTEM (REFERENCE FIGURE 5A or 5B ).**

Unless otherwise specified (see 6.2-q), the ambulance shall, when available from the chassis manufacturer, be equipped with standard or optional generating system designed for ambulance applications, and shall be nominally rated at 14 volts, with a minimum under hood temperature of 93° C (200° F). As a minimum, the generating system shall be capable of supplying at its regulated voltage, at 93° C (200° F), the continuous electrical load which consists of the following electrical equipment and systems: engine/transmission control system; headlights (low beam); all FMVSS 108 lights; windshield wipers (low speed); cab air conditioning (at coldest setting with highest blower speed); radio in receiving mode (or equal load, if not equipped); patient module dome lighting (in the high intensity setting); patient module air conditioning (at coldest setting with highest blower speed); emergency warning lighting system (in the daytime "primary" mode) (3.8.2); and 20 amp medical load or equal.

The generating system shall supply the maximum electrical load, at the regulated voltage, at 93° C (200° F) under hood temperature, and with an engine speed not exceeding of the furnished engine manufacturer's high idle setting in order to maintain battery charge at the regulated voltage. The throttle control device, specified in 3.7.6.1, shall control the engine RPM necessary to maintain the heating and air conditioning systems, at full operating capacity, and to maintain the generating system's required output when the vehicle is stationary. The 12 volt electrical system shall incorporate an ammeter (see

3.7.6.2), and a voltmeter or voltage warning device (see 3.7.6.3) which are functionally connected as shown in Figure 5A or 5B. The final stage manufacturer/supplier shall test each ambulance prior to delivery and provide,

to the purchaser, a written certification (tag) indicating the amount of generating capacity remaining, at the regulated voltage, at 93° C (200° F), after supplying the total electrical load as manufactured (including the purchaser options). Testing and tagging shall be in accordance with “AMD Standard 005, Ambulance Electrical System.”

#### **3.7.6.1 ENGINE HIGH-IDLE SPEED CONTROL, AUTOMATIC.**

An engine high-idle speed control shall be furnished on all vehicles which automatically increases the engine speed (RPM) to the engine manufacturer’s recommended setting to sustain the ambulance’s total continuous electrical load at the regulated voltage, and provide maximum heating/air conditioning output. The device shall be preset so that, when activated, it will operate the engine at the appropriate RPM (see 3.7.6). The device shall operate only when switched to the “ON” position and the transmission is in “NEUTRAL”, “PARK” and the parking brake is applied (when required by the chassis manufacturer). For transmissions without a “PARK” position, the device shall only function with the transmission in “NEUTRAL” and with the parking brake applied. The device shall disengage when the operator depresses the service brake pedal or the transmission is placed in gear, and automatically re-engages when the service brake is released or when the transmission is placed in neutral or park. The device shall be furnished by the chassis manufacturer when available.

#### **3.7.6.2 AMMETER.**

The electrical system (see Figure 5A or 5B) shall incorporate a center scale ammeter or equivalent electronic digital display which is capable of indicating a current of +/- 150 amperes or greater to exceed the worst case ampere load. The ammeter shunt, Hall Effect, or other current sensing device shall be electrically located in the electrical system to indicate all the current going to (charging) or from (discharging) the vehicle’s batteries. When specified, furnished, (see 6.2) or when the chassis manufacturer disallows the cutting of power leads, a “Hall Effect” or other similar current sensing device shall be furnished in place of the ammeter shunt. The

shunt or other current monitoring device shall not exceed 150 mV drop at maximum current. The ammeter and shunt, or equivalent device, shall have a combined accuracy of +/- 10 percent of the full scale reading. The meter shall be mounted in a location highly visible to the vehicle operator and shall be illuminated for night operation. The shunt or monitoring device shall be protected against physical damage, weather, road spray, and shall be mounted in an easily accessible location, and shall minimize the length of the power cables.

#### **3.7.6.3 VOLTMETER OR VOLTAGE MONITOR.**

A voltmeter, or equivalent electronic device, illuminated for nighttime operation, which constantly monitors the 12 volt electrical system or a warning device and indicates abnormally high or low electrical system voltages, shall be furnished. The device furnished must be mounted so it is clearly visible to the driver at all times.

#### **3.7.7 BATTERY SYSTEM.**

Two 12 volt batteries (or additional batteries as required by the chassis manufacturer) for ambulance use shall be furnished. When installed by the chassis manufacturer, a labeled "Battery Disconnect Switch" (or a switch operated solenoid) shall be furnished per Figure

5A. All electrical loads added by the ambulance manufacturer shall be controlled by an illuminated "Module Disconnect" switch or an illuminated, switch controlled, solenoid as shown in Figure 5A or 5B. Unless otherwise specified (see 3.15.3-5), the batteries shall be equivalent to the chassis OEM batteries. When high cycle batteries are specified (Delco / Delphi 1150 or 1151, or equal), ratings for each battery shall not be less than 700 cold cranking amps, and 180 minutes reserve capacity.

Battery ratings shall conform to SAE J537. Batteries shall be located in a ventilated area, sealed off from occupant compartments, and shall be readily accessible for servicing and removal. When batteries are mounted

in the engine compartment, they shall be provided with a heat shield as a safeguard against high under hood temperatures.

If the chassis manufacturer furnishes and installs the “Battery Disconnect Switch”(Fig.5A), it shall be clearly visible to the driver, in the seated position. If the switch is not visible, a green indicator light, shall be furnished indicating the batteries are “ON” (see 3.7.1.1). Battery switch / device wiring and added/ modified starting motor circuit wiring shall meet or exceed the SAE J1127 for high temperature SGX wire and SAE J541 for maximum voltage drop requirements for 12 volt heavy-duty applications.

When specified (see 6.2-R), the batteries, on Types I & III vehicles, shall be located in the module, sealed from the interior, or on Type II vehicles, in a compartment or lower skirt. Batteries shall be on a slide out tray or be readily available for service. When relocating batteries, the method of relocation shall be approved by the chassis manufacturer.

- NOTES:**
- 1. MODULE BATTERY LOCATIONS CAN PROVIDE FOR IMPROVED FRONT/REAR AND LATERAL WEIGHT DISTRIBUTION AND FOR A LOWER CENTER OF GRAVITY.**
  - 2. PURCHASERS SHOULD SPECIFY A BATTERY CONDITIONER TO RECHARGE WHEN NECESSARY, AND TO MANTAIN CHASSIS BATTERIES IN THEIR FULL STATE OF CHARGE REGARDLESS OF PARASITIC LOADS. (THE BATTERY CONDITIONER WILL RECHARGE PORTABLE EQUIPMENT BATTERIES WITHOUT DRAINING CHASSIS BATTERIES. SEE 3.7.7.2)**

#### **3.7.7.1 BATTERY CHARGER OR CONDITIONER.**

When specified (see 3.15.3-7), either a 12 volt DC taper type battery charger or automatic charger/conditioner shall be provided. The charger/conditioner shall be listed by an organization meeting the requirements in Paragraph 3.7.8



and connected to the 12 volt DC battery system as shown in Figure 5A or 5B, and Figure 7. The charger shall be capable of supplying a minimum of 10 amperes charging current. The charger/conditioner shall be permanently mounted, in the vehicle, in a properly ventilated, accessible location and wired to the 115 volt AC utility power as specified in 3.7.8 and Figure 6.

When a battery conditioner is provided, it shall monitor the battery state of charge and, as necessary, automatically charge or maintain the batteries without gassing, depleting fluid level, overheating, or overcharging.

#### **3.7.7.2 PORTABLE EQUIPMENT CHARGING CIRCUIT.**

A circuit shall be furnished (Figure 7) for charging all portable battery powered devices, i.e. suction units, hand lights, defibrillators, portable radios, etc. This circuit shall

prevent discharge of chassis batteries by only permitting the charging of portable devices when the vehicle is either running or the battery conditioner is connected to shore power (operational). Circuit breaker protection shall be provided and shall have a minimum of 10 amp capability. An additional tagged, identified lead shall be furnished in both the cab and module for connection of additional (future) portable equipment that requires recharging. When specified by the purchaser, (see 3.15.3-7) additional leads shall be furnished, and shall be located in areas as designated by the purchaser. A permanently mounted decal or engraved plate shall be furnished in a conspicuous location in the cab stating, "This vehicle is equipped with a battery conditioner to maintain batteries in a full state of charge, and a dedicated 12 volt recharging circuit for portable battery powered equipment. For operation, vehicle shall be plugged into 115 volt AC shore power during periods of non-use".<sup>9</sup>

#### **3.7.7.3 INTERNAL 12 VOLT DC POWER (REFERENCE FIGURE 5A or 5B).**

Unless otherwise specified by the purchaser, two automotive "Power Point" type connectors shall be furnished (see 6.2-s), in the patient compartment. Each connector shall be rated for 12 volt DC, 20 ampere capacity, and be on a separately protected circuit. This circuit shall also include a (low voltage drop) "Schottky" diode to isolate medical equipment batteries from any electrical loads that the remainder of the ambulance

electrical system may impose. The “Schottky” diode shall be heat-sink mounted, have an inverse voltage rating of at least 45 volts and also be rated to carry the maximum short circuit current, until the circuit breaker opens. The diode shall be physically located in an accessible location and be electrically connected between the circuit breaker and the “action wall” mounted connectors. When specified (see 6.2-s), the receptacles shall be a military type connector of the following generic designation, MS3112E12-3S or its interchangeable commercial equivalent. The polarity of the connector shall be as follows: Pin A (+ 12V), Pin B (Ground), Pin C (not used). The receptacles shall be located on a vertical surface of the “action wall” or other location specified by the purchaser. The mating plug attached to the medical equipment shall be an MS3116F12-3P or its interchangeable commercial equivalent. The polarity for the plug shall be the same as above. Two unwired plugs shall be furnished and tagged with polarity requirements, and shall be plugged into the connectors. (NOTE: These connectors are widely available directly from most major industrial electronics distributors.)

#### **3.7.7.4 MASTER MODULE DISCONNECT SWITCH OR DEVICE.**

This switch (see Figure 5A or 5B) shall be located in the driver’s compartment, be legibly marked, illuminated when “ON”, and rated to carry at least 125 percent of the circuit’s maximum current.

#### **3.7.8 115 VOLT OR 115/230 AC UTILITY POWER (REFERENCE FIGURE 6).**

Unless otherwise specified, the ambulance shall be furnished with a 2-wire plus ground 115 volt AC wiring system that is separate and distinct from the vehicle’s 12 volt DC wiring system(s). The AC electrical system, including wiring and associated equipment, shall comply with AMD Standard 009. Listing shall be by a nationally recognized testing laboratory, recognized by OSHA under Appendix A to 29 CFR 1910.7. The AC system is to be utilized while the vehicle is stationary for powering maintenance devices, medical equipment battery chargers, and when specified (see 3.15.3 & 6.2), vehicle battery conditioner/charger, and any other device(s) deemed necessary by the purchaser. The AC system shall incorporate a ground fault circuit interrupter (GFCI) device and a minimum

15 ampere circuit breaker which can be used as a master AC disconnect switch. The GFCI and circuit breaker may be an integral unit. The AC wiring shall utilize stranded wire in armored cable, nonmetallic sheathed cable, "Type SO" or better flexible cable rated at

600V and 90° C., covered with a minimum 149° C (300° F). flame retardant wire loom, or approved wire in conduit.

When an onboard AC supply is specified (see 3.7.8.3), an automatic transfer switch shall be furnished which turns off this onboard AC supply (interlock) and disconnects its output, when the AC utility power is applied.

When the 12 VDC battery charger (see 3.15.3-7) and any power plant heater(s) (see 3.15.3-

16) are furnished and connected to this system, they shall be wired so that they can be energized only from the utility power, and not the onboard AC supply. The onboard AC system shall not be utilized for operational ambulance interior lighting, such as dome and cot lights.

**30**

### **3.7.8.1 UTILITY POWER CONNECTOR.**

Unless additional capacity is required, a 115 volt AC (male) plug (NEMA 5-15P), rated at 15 amps (similar to a Levitan 4937, Arrow-Hart 527WP or equal), with spring loaded cover assembly suitable for wet locations, shall be installed on the driver's side of the ambulance body in close proximity to driver's door. The connection shall be permanently labeled with the following:

**THIS CONNECTION IS FOR 115 VOLT AC, 60 Hz, 15 AMPERE SUPPLY.**

This receptacle shall energize the vehicle's internal AC circuit(s) from an external power source (utility power). The purchaser's stationary utility power circuit supplying the ambulance's 115 volt AC power should incorporate ground fault protection. A proper mating, weatherproof, 15 ampere or more when required, female receptacle (NEMA 5-15R) shall also be furnished without cable and tagged specifying the size, type of wire necessary, and the polarity of the future hookup.

### **3.7.8.2 ELECTRICAL 115 VOLT AC RECEPTACLES.**

The patient compartment shall be furnished with a pair of 2 wire plus ground duplex

115 volt AC receptacles. Receptacles shall be near flush, vertically mounted. One outlet shall be located on the primary patient action wall and the other shall be located in the right front cabinet / storage area. Both outlets shall be at least 31 cm (12 in.) from any oxygen outlet. An indicator shall be located within each 115 volt AC receptacle as a line monitor indicating a live (hot) circuit. The receptacles shall be labeled with the following: "115 VOLT AC."

### **3.7.8.3 SOLID STATE INVERTER FOR ON BOARD 115 VOLT AC POWER.**

When specified under 3.15.3-6, a DC to AC inverter shall be provided in conjunction with the onboard 115 volt AC wiring system (3.7.8.) The device furnished shall be capable of continuously delivering at least 750 watts of sine wave type regulated AC power to safely power all types of electrical or electronic loads and maintain a frequency of 60 +/-4 Hz. The single phase output sine wave type regulated voltage, with minimal harmonic distortion, shall not rise to more than an RMS value of 135 volts nor drop to less than 105 volts from no load to full load, at an 80 percent power factor, over the 12.8 to 14.8 range of the DC input voltage. The device shall be capable of operating all types of AC loads, including resistive and reactive (either inductive or capacitive) over the temperature range in 3.4.2. The installation shall include an "ON-OFF" switch to activate the device. This switch shall be located on the EMT's control panel or cab console, have a red "ON" indicator, and be labeled with the following: "115 VOLT AC Inverter." A decal shall be provided near this switch, which states that "WHEN OPERATING THE 115 VOLT AC SYSTEM, ALL UNNECESSARY 12 VOLT DC ELECTRICAL LOADS SHOULD BE TURNED OFF." The inverter shall have integral GFCI protection and shall be wired per Figures 5A or 5B, and 6

### **3.7.9 DRIVER COMPARTMENT CONTROLS.**

In addition to the left-hand drive controls and switches, the final stage ambulance manufacturer shall provide and locate, within easy normal reach of the driver, the specified controls and instruments. The battery switch (when furnished), and module disconnect switch or device (see 3.7.7.4) shall be different in feel from each other and be supplied with a handle or knob, which feels different to the touch than the other switches, or be physically isolated from them.

### **3.7.10 PATIENT COMPARTMENT CONTROLS.**

Unless otherwise specified by the purchaser (see 6.2-t), the patient compartment controls, switches, and instruments shall be panel mounted and located within normal reach of the seated EMT (3.10.3).

### **3.7.11 MARKING OF SWITCHES, INDICATORS, AND CONTROL DEVICES.**

All switches, indicators, and control devices supplied by the end product manufacturer of the ambulance shall be clearly visible to the ambulance personnel. They shall be perceptively and permanently identified with at least 12 point letters for the noun or function, and 8 point letters for the remainder of the legend. The identifications shall be contrasting colors etched or engraved in plastic or metal, or printed and laminated in see through plastic, and grouped according to function, and mounted in illuminated or backlit panel(s) or the console.

### **3.7.12 ELECTROMAGNETIC RADIATION AND SUPPRESSION.**

In addition to OEM chassis, all added electrically operated or electrical generating devices, including alternators, air conditioning, warning light systems, electromagnetic coils of high current solenoids and relays, and medical equipment, shall be electromagnetic radiation suppressed, filtered, or shielded to prevent interference to radios and telemetry equipment aboard the vehicle and the surrounding area and shall not exceed SAE J551 limits. Type certification for these devices is acceptable. When specified by the purchaser (see 6.2-u), the completed ambulance vehicle shall be tested and certified to demonstrate that the RFI

does not exceed the maximum limits of SAE J551. When specified by the purchaser, electrically operated medical equipment, both installed and portable, furnished shall comply to MIL-STD-461, Interface Standard Requirements for the Control of Electromagnetic Interference Characteristics of Subsystems and Equipment.

### **3.8 LIGHTING, EXTERIOR AND INTERIOR.**

#### **3.8.1 AMBULANCE EXTERIOR LIGHTING.**

The basic exterior ambulance lighting shall comply to FMVSS No. 108 and the requirements herein, and include daytime running lights when standard from the chassis manufacturer, amber colored front and rear directional signals and hazard warning lights (except on Type II ambulances, if amber lenses are not available from OEM). The lower front and rear side marker lights shall flash in conjunction with the directional signals. Backup lights/loading light(s), clearance lamps (when applicable), ambulance emergency lights (3.8.2), floodlights (3.8.3), and spotlight(s) (3.8.4) (see Figures 1, 2, and 3), shall be furnished as specified. The ambulance manufacturer shall furnish light assemblies that are stainless steel, plastic, or other weather resistant materials, that are installed in a manner that will not cause electrolysis of light housings or vehicle body.

#### **3.8.2 AMBULANCE EMERGENCY LIGHTING.**

As specified (see 6.2-v), a strobe, halogen, HID, LED, or any other source of light for the emergency lighting system shall provide the ambulance with 360 degrees of conspicuity for safety during its missions. The system shall display highly perceptible and attention- getting signals that function in a modal system, and convey the message in the “PRIMARY MODE” - “Clear the Right-of-Way” and in the “SECONDARY MODE” - “Hazard, Vehicle Stopped on Right-of-Way.” The ambulance standard warning light system shall not impose a continuous average electrical load exceeding 40 amperes at 14.2 volts and 42 amperes with the optional second amber rear light.

Additional warning lights are not required but, if specified (see 6.2-v), shall not obscure the light output of the standard warning light system. Additional

warning light systems furnished shall be separately switched. Any warning devices furnished, in addition to the specified system, shall be compensated for with reserve or additional generating capacity as required in 3.7.6.

#### **3.8.2.1 EMERGENCY LIGHTING SYSTEM CONFIGURATION.**

The ambulance standard emergency warning light system shall contain twelve fixed red lights, one fixed clear light and one or two fixed amber or SAE “selective yellow” light(s), (see 6.2-v).

These lights shall function in a dual mode system as shown in Table I below and meet the physical and photometric requirements of 3.8.2.2. The upper body warning lights shall be mounted at the extreme upper corner areas of the ambulance body, below the horizontal roofline. The single clear light shall be centered between the two front facing, red, upper corner lights or in a dedicated housing mounted forward of the body on the cab roof (see Figures 1, 2, and 3). If due to limited body dimensions and physical size of the outboard forward facing lights, the lights may also be mounted in dedicated housings on the cab roof. The standard warning lights shall not be obstructed by doors or other ancillary equipment. The amber light(s) shall be symmetrically located between the two rear facing red lights. The red “grille” lights shall be located at least 76 cm (30 in.) above the ground and below the bottom edge of the windshield and be laterally separated by at least 46 cm (18 in.), measured from centerline to centerline of each lamp. The lateral facing intersection lights shall be mounted as close as possible to the front upper edge of each front fender and may be angled forward a maximum of 30 degrees. All warning lights furnished shall be mounted to project their highest intensity beams on the horizontal plane, (see 3.8.2.4).

#### **3.8.2.2 PHOTOMETRIC, CHROMATICITY, AND PHYSICAL REQUIREMENTS.**

Each emergency light shall flash 75 to 125 times per minute. The chromaticity values of the lights shall conform to SAE J578, for their respective color, except for the red lights, which in addition may conform to the following expanded boundary limits of:  $y = -0.34$ ;  $y = 0.32$ ;  $x = 0.62$ . All warning lights shall project a beam spread of at least 5 degrees up and 5 degrees down and at least 45 degrees left and right of H-V. Each light shall produce flash energy, (Cd-s) per flash, measured from the H-V to all the extreme test point coordinates and shall be tested at all 5° increments. At no point

shall the Cd-s values drop to less than the minimum values as shown in the table above when tested at 14.2 volts. Flash energy shall be determined in accordance with the SAE J845 method for determining the flash energy of a light. Testing shall be conducted on the device(s) as manufactured including use of the actual light source and all other related system components.

### **3.8.2.3 SWITCHING ARRANGEMENTS.**

The emergency light switches shall be wired and arranged to provide the warning light signal modes and combinations as specified. All emergency light switches shall be labeled (see 3.7.11) and each Primary/Secondary mode switch shall have an amber or red indicator light to show the driver which mode is activated. When strobe lights are furnished or, when specified (see 6.2-v) for incandescent lights, a day-night switch shall be provided. When specified (see 6.2-v) from the lighting system manufacturer, an automatic switch to the "Secondary Mode" when the gear selector is placed in the "Park/ Neutral" position, with a manual override to the "Primary Mode" shall be furnished. Additionally, when specified (see 6.2-v) from the lighting system manufacturer, the lighting system shall provide an ambient light sensing circuit to automatically switch to the

"Night" position while in the "Secondary Mode". A manual override to the daytime (bright) mode shall be provided. Operators manual (3.20) shall include suggestive management instructions for the warning systems.

### **3.8.2.4 HARDWARE CONSTRUCTION AND INSTALLATION.**

The emergency lighting system shall be comprised of components and devices that comply to the general requirements and tests of SAE J575g, J576d, J578, and J551, as applicable for the unit. Warning lights shall be firmly fastened to reinforced body surfaces in accordance with the lighting manufacturer's requirements and recommendations and include aiming wedges to compensate for sloped body surfaces, grill, hood and fender angles or mold release angles on roof caps. The ambulance manufacturer shall aim the lights to assure that all lighting performance requirements herein are met. The lights shall be aimed either mechanically or optically on the horizontal axis with a tolerance of +0 degrees to -3 degrees. All switches, connectors, and wiring shall be rated to carry a minimum of 125 percent of their maximum ampere load. When halogen or other long



duty cycle light source is used, the duty cycle of any device shall not exceed 50 percent. When strobe lights are furnished, all high voltage leads and connections shall be insulated and enclosed, or weather proof connectors, with the proper voltage rating shall be used.

#### **3.8.2.5 TESTS, WARNING LIGHT SYSTEM.**

The lighting manufacturers shall furnish and certify or the ambulance manufacturer shall measure and record the total average current load of the standard emergency warning light system on the vehicle as manufactured at the regulated voltage of 14.2 V, when operated in the mode which draws maximum current. This load current test shall be conducted during the “ambulance’s electrical system test” (3.7.6 and AMD Std. 005). The warning light system and related components and devices shall conform to temperature conditions in 3.4.2 and be tested and approved by an Automotive Manufacturers Equipment Compliance Agency (AMECA) accredited laboratory independent from the lighting device manufacturer’s own labs and listed with the AMECA for compliance with the requirements in this specification.

#### **3.8.3 FLOOD AND LOADING LIGHT (EXTERIOR).**

Flood and loading lights shall be not less than 191 cm (75 in.) above the ground and unobstructed by open doors. Floodlights shall be located on the sides, and a patient loading light on the rear of the ambulance. They shall be firmly fastened to reinforced body surfaces, below the roofline. When specified by the purchaser (see 6.2-w) two flood lights shall be furnished on each side, and two patient loading lights shall be furnished on the rear. These flood lights shall be mounted on fixed body surfaces, and should have the maximum possible spacing between them. The lamp(s) H-V shall be projected downward, either mechanically or optically, at an angle of 12 to 18 degrees from the horizontal plane and the lighting on each side of the ambulance shall provide a minimum of 800 beam candle power and produce a flood light pattern similar to a H7619 sealed beam lamp. Floodlight switches shall be located on the cab console and control each side independently.

Loading light(s) shall provide a minimum of 500 candle power beam and shall illuminate the area surrounding the back loading doors. The light(s) shall produce a light pattern equivalent to a 4406 sealed beam. Loading light(s) shall automatically be activated when rear doors are opened and may be incorporated with the FMVSS backup lighting system.

#### **3.8.4 SPOTLIGHT.**

A hand held spotlight shall be provided with a minimum 100,000 CP lamp, corrosion- proof housing with momentary switch, and minimum 244 cm (8 ft.) heavy-duty coiled cord. It shall be hard wired to the vehicle 12 volt DC system (for anti-theft reasons) and stowed in a holder in a compartment/area, accessible to the driver and passenger. When specified (see 3.15.3-25), a remote controlled spotlight shall be furnished, having an "ON"/"OFF" panel switch and variable speed fingertip control. Searchlight shall be a minimum

13 cm (5 in.) diameter, 100,000 CP sealed beam. Lights shall be operable over 360 degrees horizontal sweep and approximately 90 degrees vertical range. Remote control, exterior, light housings shall be chrome plated, bronze, brass, or other materials with intrinsically corrosion resistant construction.

#### **3.8.5 AMBULANCE INTERIOR LIGHTING.**

The basic interior ambulance lighting configuration shall be designed to minimize electrical loads and include: A driver's compartment dome light; instrument panel lights; master switch panel; and console light(s). When specified (see 3.15.3-33), a map light for the front seat passenger shall be furnished. Lighting shall be designed and located so that no glare is reflected into the driver's eyes or his line of vision, from switch control panels or other areas that are illuminated while the vehicle is in motion. The patient compartment dome lighting (3.8.5.1) shall be sufficient to illuminate the step-well (3.10.12). The EMT's control panel shall be separately illuminated. All lights shall have lamp shells and housings grounded.

##### **3.8.5.1 PATIENT COMPARTMENT ILLUMINATION.**

Normal white illumination (dome and EMT's switch panel lighting) in the patient compartment shall not be less than 15 foot candle intensity, measured along the centerline of the clear floor without any outside ambient light. The primary cot shall be provided with a minimum of 35 foot candles of illumination measured on at least 90 percent of the cot's surface area. Blue light(s) or lenses shall not be used. Patient compartment lights shall not be powered by the vehicle's 115 volt AC system if so equipped. The patient compartment dome lighting (in the dim setting) and loading lamp(s) shall be automatically activated when the patient compartment doors are opened. All interior dome lighting, including "checkout" lights, shall be near flush mounted and not protrude more than 3.8 cm (1.5 in.). The use of fluorescent lighting which operates on 12 volts DC, meets the above performance and interference requirements of paragraph 3.7.12, can be used in lieu of incandescent lighting. Fluorescent fixture(s) shall have a removable cover that positively locks in place. The fluorescent tube shall be positively locked in place to preclude loosening due to vehicle movement or vibration.

Dome lighting shall not consume more than 15 amps in the bright setting and shall have two separately protected and controlled circuits. Switches, electronic controls, or fireproofed rheostats may be used to control lighting.

#### **3.8.5.2 PATIENT COMPARTMENT "CHECKOUT LIGHTS".**

When specified (see 3.15.3-9), two "patient compartment checkout lights" shall be furnished with 6 candle power lamps, or equal, and 5 minute timer switch that is wired directly to the ammeter shunt (battery side of load disconnect switch). (See Figure 5A and 5B). One of the light fixtures shall be located towards the front of the patient compartment and one towards the rear. The checkout lights may be integrated into the standard patient compartment lighting by activating two of the lamps in the "dim" circuit.

## Appendix D

SolidWorks Renderings



**Render 1 – Left View**



**Render 2 - Right View**



**Render 3 - Front View**



**Render 4 - Rear View**



**Render 6 - Open Back Isometric**



**Render 5 - Open Back Door**





**Render 7 - Right Side Interior Section**



**Render 8 - Left Side Interior Section**

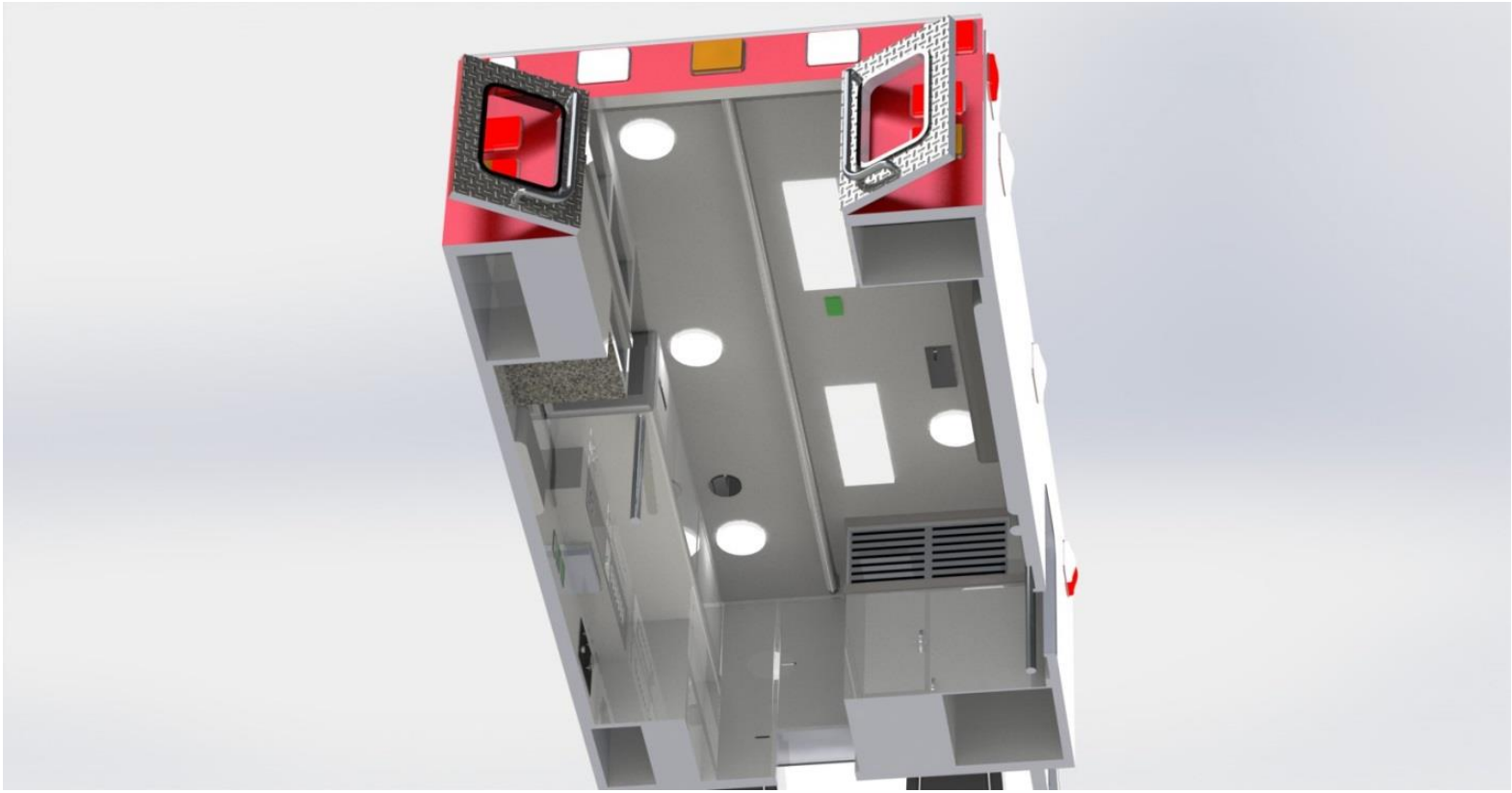

**Render 9 - Ceiling Section View**