

MQP-PPM-WPI5  
MQP-SL1-WPI5



## Stormwater Management on WPI's Campus MQP Report

Written by:  
Brian Marsh, CE  
Ian McMullen, EVE  
Jacob Grills, CE

Advised by;  
Suzanne LePage  
Paul Mathisen

*This report represents the work of WPI undergraduate students submitted to the faculty as evidence of completion of a degree requirement. WPI routinely publishes these reports on its website without editorial or peer review. For more information about the projects program at WPI, please see <http://www.wpi.edu/academics/ugradstudies/project-learning.html>*

**Abstract**

Pollutants carried in stormwater runoff pose a threat to the water quality of receiving water bodies. This project addressed these concerns at WPI through the design of a stormwater best management practice (BMP) and creation of a stormwater management strategy. Stormwater BMP's were analyzed for their effectiveness in pollutant removal, and a tree box filter was ultimately designed. The stormwater management strategy would address the six minimum control measures as defined by the EPA to improve stormwater management at WPI.

## Capstone Design Statement

In order to fulfill the requirements as students of Worcester Polytechnic Institute the Accreditation Board for Engineering and Technology (ABET) states that

“Students must be prepared for engineering practice through curriculum culminating in a major design experience based on the knowledge and skills acquired in earlier course work and incorporating engineering standards and realistic constraints that include most of the following considerations: economic, environmental, sustainability; manufacturability; ethical; health and safety; social; and political.” To address this, our group designed a tree box filter to treat stormwater runoff, taking into account the following constraints:

- **Economic:** Upon selection of the discovered problem area, we determined the most cost effective best management practice. Being cost effective entailed how the BMP cost versus how much load it relieved.
- **Environmental:** The decrease of concentration of pollutants in runoff from our best management practice implementation was designed in an effort to decrease the pollutant load on the receiving water bodies such as Salisbury Pond.
- **Sustainability:** When choosing a BMP, its long-term effects on the environment were another main factor in the decision. Long-term effects being how much it would improve the environment over time and if the equipment being used would have an adverse effect over time as well. The BMP was designed to last into future years.
- **Ethical:** The fault of pollutants entering local water bodies through stormwater transportation falls on our population as a whole. As engineers and under the ASCE Code of Ethics canon 1 “Engineers shall hold paramount the safety, health and welfare of the public and shall strive to comply with the principles of sustainable development in the performance of their professional duties.” Therefore it is our duty to do what is best for the environment and the public and help to improve the quality of the waters surrounding WPI.

- **Health and Safety:** The design and installation of a stormwater BMP would decrease the amount of pollutants into the receiving water body. Pollutants are harmful to aquatic as well as human life, hence improving health and safety.
- **Social and Political:** The stormwater management strategy we developed is to be an example and a standard that others will model after. We hope to gain awareness for stormwater management by making WPI the name associated with going green and improving the environment.

## **Licensure Statement**

Licensure is defined as the granting of licenses, especially to practice a profession. To obtain a Professional Engineer's license for civil engineering, a series of four steps must be completed, starting with earning an ABET-accredited engineering degree. The next step toward licensure is passing the Fundamentals of Engineering (FE) exam. The test material ranges from topics such as mathematics and statics, to materials and fluids. The FE exam can be taken at any time in an engineer's career, but is typically first attempted in the months prior to completion of undergraduate studies. Once the FE exam is passed, the next step is gaining professional experience in the civil engineering field, typically considered to be four years working under the supervision of a licensed professional engineer.

After gaining professional experience, the Professional Engineer (PE) exam can be attempted. This is the final step towards becoming a licensed Professional Engineer. There are five different versions of the exam, construction, geotechnical, structural, transportation, and water resources and environmental, depending on the desired discipline (NCEES, 2014). Once the exam is passed, Professional Engineer licensure is achieved.

Gaining licensure can lead to a number of advantages for an engineer. First and foremost, only a licensed engineer can prepare, sign and seal, and submit engineering plans and drawings to a public authority for approval (NPEES, 2015). Licensure also has some indirect effects, primarily marketability while searching for a job. Being able to claim licensure makes a potential employee much more attractive to an employer, leading to increased opportunities for work. Ultimately, licensure is a symbol of dedication, and assurance of competence in the engineer's field.

## Table of Contents

<b>List of Figures</b> .....	<b>8</b>
<b>List of Tables</b> .....	<b>9</b>
<b>1.0 Introduction</b> .....	<b>10</b>
<b>2.0 Background</b> .....	<b>12</b>
<b>2.1 Stormwater</b> .....	<b>12</b>
<b>2.2 Stormwater Regulations</b> .....	<b>13</b>
2.2.1 Municipal Separate Storm Sewer System.....	14
2.2.2 Salisbury Pond.....	15
<b>2.3 Geographic Information Systems (GIS)</b> .....	<b>17</b>
<b>2.4 Load Quantification Methods</b> .....	<b>18</b>
2.4.1 Simple Method.....	18
<b>2.5 Best Management Practices in Urban Areas</b> .....	<b>19</b>
2.5.1 Permeable Pavement .....	19
2.5.2 Tree Box Filters .....	20
2.5.3 Rain Barrels and Cisterns.....	21
<b>2.6 Stormwater Management Plans</b> .....	<b>22</b>
2.6.1 A Stormwater Master Plan for the University of Pennsylvania.....	22
2.6.2 Stormwater Management Plan Template.....	23
2.6.3 Creating a Stormwater Management Strategy .....	24
<b>3.0 Methodology</b> .....	<b>26</b>
<b>3.1 GIS Analysis</b> .....	<b>26</b>
3.1.1 Create Base Map.....	26
3.1.2 Map Predicted Stormwater Runoff Flow .....	28
3.1.3 Identify Drainage Areas .....	28
3.1.4 Impervious Area Totals.....	28
<b>3.2 Load Analysis</b> .....	<b>29</b>
3.2.1 Simple Method Analysis.....	29
<b>3.3 Identification of BMP Location</b> .....	<b>30</b>
<b>3.4 Evaluation of BMP's</b> .....	<b>30</b>
<b>3.5 BMP Design</b> .....	<b>31</b>
<b>3.6 Analysis of BMP</b> .....	<b>31</b>
<b>3.7 Developing a Stormwater Management Strategy for WPI's Campus</b> .....	<b>31</b>
<b>4.0 Results and Analysis</b> .....	<b>33</b>
<b>4.1 GIS Analysis</b> .....	<b>33</b>
4.1.1 Base Map.....	33
4.1.2 Flow Analysis .....	34
4.1.3 Drainage Areas Determined.....	35
4.1.4 Impervious Areas .....	36
<b>4.2 Load Analysis</b> .....	<b>36</b>
<b>4.3 Identification of BMP Location</b> .....	<b>38</b>
<b>4.4 Evaluation of BMP's</b> .....	<b>39</b>
<b>4.5 BMP Design</b> .....	<b>40</b>
<b>4.6 Analysis of Tree Box Filter</b> .....	<b>41</b>
<b>4.7 Stormwater Management Strategy for WPI's Campus</b> .....	<b>41</b>
4.7.1 Introduction and Goals.....	42

4.7.2 Existing Conditions .....	42
4.7.3 Public Education .....	43
4.7.4 Public Involvement and Participation .....	43
4.7.5 Illicit Discharge Control .....	44
4.7.6 Construction Site Runoff Control .....	44
4.7.7 Post Construction Runoff Control.....	45
4.7.8 Pollution Prevention .....	45
4.7.9 Best Management Practices .....	45
<b>5.0 Conclusions .....</b>	<b>46</b>
<b>Works Cited .....</b>	<b>47</b>
<b>Appendices.....</b>	<b>50</b>
<b>Appendix A: Stormwater Management on WPI's Campus Project Proposal.....</b>	<b>50</b>
<b>Appendix B: Surveying Results.....</b>	<b>76</b>
<b>Appendix C: Tree Box Filter Design Details and Additional Views.....</b>	<b>77</b>
<b>Appendix D: A Stormwater Management Strategy for WPI.....</b>	<b>79</b>

List of Figures

Figure 1: ArcGIS Base Map .....	33
Figure 2: Flow Analysis Map.....	34
Figure 3: Drainage Areas.....	35
Figure 4: Tree Box Filter Site Rendering .....	40
Figure 5: Essential Elevations Map .....	76



## List of Tables

Table 1: TMDL Load Allocations .....	17
Table 2: GIS Base Map Layers .....	27
Table 3: Drainage Areas Total Areas .....	36
Table 4: Impermeable Areas of Drainage Areas .....	36
Table 5: Annual Pollutant Loads .....	37
Table 6: Pollutant Loads per Acre .....	39
Table 7: BMP Analysis .....	39
Table 8: Filterra Removal Rates .....	41

## 1.0 Introduction

Stormwater runoff creates major problems in our ponds, lakes and rivers due to the high amount of chemicals and sediments it contains, as it is not treated before it enters the water body. These pollutants build up in the water and cause problems for aquatic life. Sediments and fertilizers from residential runoff can cause water turbidity and excess nutrient growth decreasing the amount of oxygen available in the water. Pollutants from automobiles such as oil and antifreeze are toxic to wildlife and can make waters unsafe for recreational use. (Clean Water Education Partnership, 2013).

Stormwater management is becoming an increasingly important topic in the United States. A significant amount of legislation is being passed with techniques being developed to improve the effectiveness of stormwater management. (EPA, 2012) One method of improving stormwater management is to create a stormwater management plan (SMP), which allows for a governing body to spell out their goals related to stormwater management, and define their means of achieving these goals. This is something that WPI does not currently have in place. WPI has proven to be a very progressive institution, even recently in terms of stormwater management. In 2008, WPI installed Worcester's first green roof, located atop the then newly constructed East Hall. This project seeks to build off this accomplishment, and keep WPI moving in the right direction in regards to stormwater management.

The goal of this project was to decrease the concentration of pollutants entering the city's drainage system from WPI's campus through the completion of the following deliverables:

- A Stormwater Management Strategy, serving as a modified SMP for WPI's campus
- The design of a Stormwater Best Management Practice (BMP) on campus

The following report details the methods that were utilized throughout this project to complete the deliverables stated above. Relevant background information is also provided to help understand the methods utilized, which are as follows:

- A Geographic Information Systems (GIS) analysis of WPI's campus
- Mapping Runoff flow and Completing a Load Analysis of Runoff
- Design of BMP taking into account pollutant loads and feasibility of design in regards to campus geography

The last portion of the project is the creation of a Stormwater Management Strategy for WPI's campus. After investigating background information regarding stormwater management plans on a college campus, and essential elements of stormwater management plans, a unique format was created to be utilized as a Stormwater Management Strategy for WPI's campus.

## 2.0 Background

In this section, background information will be presented that will be helpful in understanding the goals and steps of this project. An overview of stormwater itself will be given, along with background information in regards to methods that will be utilized throughout the project. One of the key components of this project is the creation of a Stormwater Management Strategy for WPI. To provide a better understanding of what it is this project will accomplish with this, an overview of stormwater management plans will be presented as well.

### 2.1 Stormwater

Stormwater is water collected on the ground from either rain or snow. In an ideal environment stormwater would slowly infiltrate into the soil and naturally filter away pollutants before entering a water body. With the current development in our cities, impervious surfaces such as roads, sidewalks and buildings speed up the water's path to a waterbody. Since the stormwater is not allowed to penetrate the surface, it enters the waterbody unfiltered with any pollutants it collects.

Comparing runoff between pervious and impervious surfaces

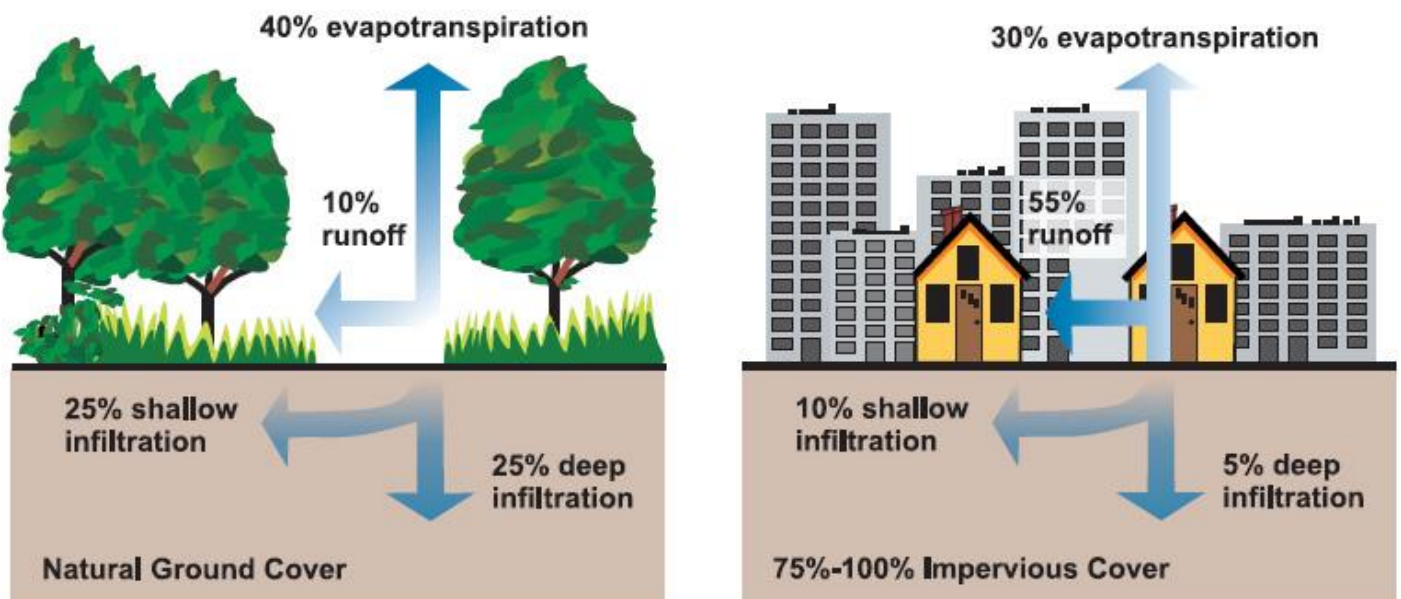

(Green Technology, 2013)

When the unfiltered stormwater enters the waterbody many pollutants such as sediments, excess nutrients, household hazardous waste, debris and pathogens enter the ecosystem. Sediments cloud the water, making it difficult for aquatic plants to grow as well as destroy aquatic habitats. (Lake Superior Streams, 2011). Excess nutrients, such as phosphorus and nitrogen, can cause algae blooms which decrease oxygen levels causing aquatic life to suffer. Household wastes like pesticides, insecticides and motor oil can poison aquatic life when entered into the water system. (EPA, 2014). Without any infiltration into the ground these pollutants enter and disrupt the natural balance.

## **2.2 Stormwater Regulations**

In Massachusetts NPDES permits are issued by EPA New England. Meaning that unlike other states, Massachusetts did not assume the NPDES program from the federal government and the state cannot issue its own permits. Worcester was issued NPDES Permit MAS010002, for discharging storm water from its municipal separate storm sewer system (MS4), which became effective on October 30, 1998 The permit expired five years later on October 30, 2003; however, EPA administratively continued the permit as allowed by regulation (EPA, 2014). This permit however applies to the City of Worcester and not WPI specifically. The permit was issued to the Department of Public Works and they are responsible for upholding the terms set by the permit. This means that WPI itself would not be directly responsible to uphold the terms of the permit within the campus but because it has stormwater that runs into the city's MS4 it must adhere to terms set in the permit when it makes a stormwater management plan.

Generally, the permit seeks to reduce stormwater pollutant loadings from Worcester's MS4 system by requiring the use of best management practices. As required by regulation, these BMPs are based on measures to reduce pollution to the maximum extent practicable and to attain state water quality standards. The permit

also requires wet-weather and dry-weather monitoring of the outfalls and receiving waters as well as updating the city's Stormwater Management Program. Referenced in this permit is also the MassDEP state developed handbook to govern the states' stormwater regulations. This handbook was also developed so that whether an area has a permit yet or not they have state guidelines to follow. (EPA, 2014)

In 1996, the Massachusetts Department of Environmental Protection (MassDEP) issued its Stormwater Policy; this policy established Stormwater Management Standards. The goal was to encourage recharge and prevent stormwater discharges from causing or contributing to the pollution of the surface waters and groundwaters in Massachusetts. In 1997, MassDEP published the Massachusetts Stormwater Handbook as guidance on the Stormwater Policy. The policy is not a requirement but meant to be used as a tool in conjunction with the NPDES permit (EPA, 2014). The handbook is the same as mentioned above meaning this Stormwater Policy should be used by non-regulated areas as well.

### **2.2.1 Municipal Separate Storm Sewer System**

MS4 stands for "municipal separate storm sewer system." It is a drainage system owned by a municipality intended to carry only surface runoff such as storm water. A separate sewer is not intended to, nor should it, carry storm water combined with sanitary sewage or with any other pollutant. A drainage system is automatically regulated if:

- The system discharges at one or more a point sources
- The drainage system is a separate storm sewer system (not designed to carry combined storm water and sanitary waste water)
- The drainage system is operated by a public body
- The drainage system discharges to the Waters of the United States or to another MS4, AND
- The drainage system is located in an "Urbanized Area".

In the Phase II Rule, EPA uses the US Bureau of Census definition of Urbanized Area (UA). The mapping of Urbanized Areas is based on the most recent federal census data. This definition is uniform nationally and has a statistical basis (EPA, 2014).

For Worcester, Permit MAS010002 regulates the MS4. The permit allows all stormwater to be discharged into United States waters through all existing or new out falls operated by the Worcester DPW. The area the permit covers as stated by the permit is as follows:

“This permit covers all areas within the corporate boundary of the city of Worcester served by, or otherwise contributing to discharges from new or existing separate storm sewers owned or operated by the Department of Public Works.”

WPI stormwater enters city outfalls therefore; they must operate under the conditions of the permit and follow said conditions when making a stormwater management plan. WPI should do what is necessary to follow NPDES guideline and requirements. Conditions such as not discharging toxics at a toxic level, and no discharging of pollutants in quantities that would violate the water quality standards, it is important for WPI to dispose of waste properly and keep the MS4 systems clean.

### **2.2.2 Salisbury Pond**

The Massachusetts Department of Environmental Protection (DEP) is responsible for monitoring the waters in Massachusetts, identifying waters that are impaired, and developing plans to bring them back into compliance with the Massachusetts Water Quality Standards. The list of impaired waters, known as the 303d list identifies river, lake, and coastal waters and the reason for impairment.

Once a body of water is identified as impaired, the DEP is required by the Federal Clean Water Act to develop a pollution budget designed to restore the quality of the impaired body of water. Developing this budget is generally referred to as a Total Maximum Daily Load (TMDL) and includes identifying the sources of the pollutant from direct discharges that are point sources and indirect discharges that are non-

point sources. Also they must determine the maximum amount of the pollutant that can be discharged to a specific water body to meet water quality standards, and develop a plan to meet that goal.

Salisbury Pond is listed on the 303d list for Nuisance Aquatic Plants and Turbidity associated with high phosphorus loadings. These are indicators of a nutrient enriched system. In freshwater systems the primary nutrient known to accelerate a nutrient enriched system is phosphorus. Therefore, in order to prevent further degradation in water quality and to ensure that the pond meets state water quality standards, the TMDL establishes a phosphorus limit for the pond. Phosphorus sources include runoff from Massachusetts Highway I-190, stormwater from surrounding urban areas, and sewage contamination.

For this case, the TMDL is expressed in terms of allowable annual loadings of phosphorus because the growth of phytoplankton and macrophytes responds to changes in annual rather than daily loadings of nutrients. As Table 1 shows, the current estimated load is 4646 kg/year, which is nearly four times higher than the 1028 kg/year target. WPI's stormwater is expressed as part of the Drain #4 storm flow. Although this is not the worst contributor into the pond, it is still 26 kg/year over the recommended loading. The bulk of the over loading into the pond comes from the Twin Culvert Inlet which contributes 4480 kg/year of total phosphorous whereas the target load is 888 kg/year. Even though WPI comparably is at a good level, BMPs should still be implemented to decrease pollutant loads.



Source	Current TP Loading (kg/yr.)	Target TP Load Allocation (kg/yr.)
Load Allocation	0	0
Waste Load Allocation		
Twin Culvert Inlet	4480	888
Drain #4 Stormflow	149	123
Other drains and runoff	17	17
Total Inputs	4646	1028

**Table 1: TMDL Load Allocations**

\*The Twin Culvert Inlet includes illicit stormwater connections, as well as runoff from MassHighways I- 190 and city streets. These sources were not separately estimated in the report.

(Salisbury Pond, 2002)

### 2.3 Geographic Information Systems (GIS)

ArcGIS is a mapping tool that was utilized throughout the project. ArcGIS consists of data corresponding to a specific geographic location. This data can be combined to form a layered map of an area with whatever data attached that is necessary for your purpose. WPI has a GIS database available for our use, along with GIS data from the City of Worcester, which will aid us in an analysis of current drainage structures and the campus as a whole.

GIS can be a very useful tool for stormwater management. It is regularly used to monitor existing stormwater management practices by mapping existing stormwater infrastructure. Aside from this, GIS can help locate areas of concern and areas for the potential implementation of BMP's. This is done through the use of base layers (topography, water bodies) and a current stormwater management practices layer (includes current drainage structures in place). Utilizing these GIS maps, areas of concern and potential areas for the implementation of BMP's can be located. (ESRI, 2006)

One approach that was studied was that of Ed Himlan, the Director of the Massachusetts Watershed Coalition, which was presented at a WPI Stormwater Workshop in 2014. His approach stated that for communities looking to improve the

quality of local waters, first, maps to show MS4 pollutant loads should be created. After this, priorities can be determined based on the estimated loads derived from the Simple Method, and quality of receiving water bodies. With these priorities determined, BMP's can be further explored, with the goal of maximizing the reduction of total suspended solids entering receiving water bodies, at the lowest cost.

## 2.4 Load Quantification Methods

In order to accurately estimate the load a drainage area is exposed to during a storm, a computational method is required. A variety of methods are utilized when analyzing stormwater. These methods include the Simple Method and the NRCS Curve Number Method. The Simple Method is used to calculate the load of pollutants while the NRCS Method and Ration Method are used to calculate stormwater flow.

### 2.4.1 Simple Method

This method calculates the average annual pollutant load from stormwater runoff for urban areas. The simple method is used as a quick tool to find the pollutant loads a drainage area creates. Although a manual spreadsheet of the simple method was created for this project, Simple Method spreadsheets are available online. First, the simple method uses a runoff coefficient based on the soil type of the area being analyzed to calculate the annual runoff using equation 2 below. Then using the calculated runoff Equation 3 is used to calculate the annual load of certain pollutants based on how the land is being used. (Stormwater Center, 2001).

#### Simple Method Equations

$$Rv = .05 + .9Ia \quad \text{Equation 1}$$

- Ia is equal to the fraction of the land with impervious cover

$$R = P \times Pi \times Rv \quad \text{Equation 2}$$

- R is equal to total runoff in inches
- P equals annual precipitation in inches
- $P_j$  is equal to the fraction of annual rainfall of events that produce runoff (usually 0.9 because small storms produce no runoff)
- Rv is equal to the runoff coefficient as defined by Equation 2

$$L = 0.226 \times R \times C \times A \quad \text{Equation 3}$$

- L equals annual load in Lbs.
- C is equal to the pollutant concentration based on land type, found in the pollutant tables (Stormwater Center, 2001)
- A is equal to the drainage area in acres

## 2.5 Best Management Practices in Urban Areas

Best management practices (BMP's) are techniques and structures that help to either reduce the quantity of stormwater entering stormwater drainage systems or reduce the concentration of pollutants in stormwater runoff. Depending on the geography of the area, certain BMP's may be more or less feasible for use. In the case of WPI's campus, BMP's which are favorable for use in highly developed or urban areas should be considered. These BMP's are feasible for use in areas that may have limited open space and heavy foot traffic. The remainder of this section will detail a few examples of the many BMP's fitting this criteria.

### 2.5.1 Permeable Pavement

Permeable pavement is used as an alternative to asphalt or concrete surfaces, and it allows stormwater to drain through the porous surface to a stone reservoir underneath. Permeable Pavements acts as filters, purifying the water from pollutants, before allowing infiltration and restoring groundwater. The appearance of the surface is often similar to asphalt or concrete, but it is manufactured without fine materials such as sand, but instead uses a paste for a thick coating over aggregate materials to create open voids in the pavement. Although this lowers the structural integrity of the pavement, it does not show in application. (Pervious Pavement, 2014)

By filtering the water through different aggregate sizes and usually a filter fabric, permeable pavements are able to remove 95% of total suspended solids, 65% of phosphorus and 82 % of nitrogen pollutants (Invisible Structures Inc.). Pervious

pavement allows for up to 80% infiltration of stormwater at a usual rate of 3-5 gallons per minute per square foot. Maintenance includes sweeping the area of sand and debris so the particles do not collect in the voids of the pavement. (University of Maryland, 2012)

The University of Rhode Island has installed two porous asphalt parking lots totaling 6.97 acres. These were replacement lots that were made with 2.5 inch thick porous asphalt and a 2% slope to allow for maximum percolation. Underneath is a one inch thick fabric filter and 3 feet of crushed stone leading to the natural soil. The project totaled \$3,033,700 with demolition costs. This porous pavement resulted in a 95% elimination of suspended solids and a 70% elimination of phosphorus pollutants. Durability issues were seen when it received frequent use as well as when stationary cars turned their tires, but it did not affect percolation rates. (RIDOH, 2013)

### **2.5.2 Tree Box Filters**

Tree filter boxes are a type of bio-retention BMP that is often utilized in urbanized and developed areas. The basic idea behind a tree box filter is to have runoff directed along impervious surfaces toward the retention box. The retention box is accessed by the runoff through a curb inlet. Once the runoff enters the retention box it passes through an engineered soil mix, which helps filter solids and contaminants out of the runoff. After passing through the engineered soil, the runoff that makes it through enters a layer of crushed stone. It passes through the crushed stone, which provides additional removal, and makes its way towards an outlet pipe, which will then divert the treated stormwater back into the municipal stormwater system.

Tree box filters are used often in urbanized and developed areas because of their pleasing aesthetics and ease of use in retrofits. Tree box filters are able to add vegetation to areas that often lack it. They are very easy to fit into developed areas as well, as they are very compact and tie into existing stormwater systems.

In October, 2006, the Grande Dunes Marina in Myrtle Beach, SC put in 25 Filterra bio-filtration systems (a tree box filter style bio-filtration system). The Grande Dunes Marina is home to many different species of wildlife and plants, and therefore must meet specific state and federal stormwater discharge requirements (Grande Dunes, 2006). The builder's decided on installing the Filterra systems due to their high pollutant removal rates. Filterra bio-retention systems have been shown to remove pollutants at the following rates:

- Total Suspended Solids-85%
- Phosphorous-60-70%
- Nitrogen-43%
- Total Copper->58%
- Dissolved Copper-46%
- Total Zinc->66%
- Dissolved Zinc-58%
- Oil and Grease->66%

(Filterra, 2014)

### **2.5.3 Rain Barrels and Cisterns**

Rain barrels and cisterns are used for harvesting rainwater for reuse. The major difference between them is their size rain barrels are significantly smaller than cisterns. Rain barrels have much more of a residential application and can be placed outside under a down spout to collect rainwater. Rain barrels of this type are usually around 50 gallons. Cisterns are more for commercial use and they can be above ground but most are put underground. While there is theoretically no limit on size, it is usually better to include more re-use applications than to increase cistern size. Some cisterns can hold over 100,000 gallons. For an application like a college campus, a cistern may be the best option to collect rainwater. It would be a low cost way to reduce runoff volume and, for smaller storms reduce the peak runoff rates. The water that is collected is a chemically untreated "soft water" and its best uses are irrigation,

but can also be used for flushing toilets. Depending on the type of system installed some don't require pumps and can use gravity to transport water (Kowalsky, 2015).

## **2.6 Stormwater Management Plans**

Stormwater management plans (SMP's) have become more and more common throughout the country. Stormwater management is increasingly becoming a concern for the EPA, as they are even beginning to offer incentives and assistance to communities to help them implement strong stormwater programs. (EPA, 2013) These plans create an opportunity for municipalities to be more effective in controlling their stormwater runoff by allowing them to clearly define what their goals are, and the necessary actions to work toward these goals. (Yale, 2013)

To attain a better understanding of SMP's, an overview of two documents will be given. The first document, a SMP designed for the University of Pennsylvania, will provide some reference as to what SMP's on college campuses typically seek to accomplish. The second document is a SMP template, developed by Linsey Payne, a master's student at the University of Oregon in 2012. An overview of this document will provide background about sections to be potentially included in a Stormwater Management Strategy for WPI's Campus.

### **2.6.1 A Stormwater Master Plan for the University of Pennsylvania**

The primary goal of this plan was to "identify opportunities to incorporate sustainable stormwater management practices into future projects," which is a focus of many SMP's on college campuses, as they have fewer regulations to meet than a municipality would. Reviewing the plan, the main sections were found to include:

- Executive Summary
- Stormwater Runoff from Today's Campus
- Stormwater Management on Today's Campus
- Potential Stormwater Management Practices for Future Projects
- Finding Sustainable Stormwater Management Opportunities

- Stormwater Management Costs and Fees
- Operations and Maintenance Considerations
- Legislation Issues and Funding Opportunities
- Recommendations

This plan provides good background information with regards to the basics of a Stormwater Management Plan for a university, as well as details numerous projects UPenn has completed that were able to incorporate stormwater BMP's. Since 2006, UPenn projects have been able to incorporate stormwater BMP's including green roofs, porous pavements, and bio-retention areas (UPenn, 2013). With WPI's inclusion of a green roof in the construction of East Hall in 2008, the potential for continued inclusion of stormwater BMP's in future projects is there as well.

#### **2.6.2 Stormwater Management Plan Template**

Created at the University of Oregon, this document, "Stormwater Management Plan Template" (Payne, 2012), provided a detailed outline for one method of creating a SMP. The fundamental structure described in this document consists of two main sections. This first section described should outline existing conditions and should set the stage for the second section. The second section should detail the means and methods that will be implemented through the plan. The document broke up the latter section into the following sub-sections, covering the six EPA recommended minimum control measures:

- Public Education
- Public Involvement
- Illicit Discharge Detection
- Sediment and Erosion Control
- Post-Construction Control
- Pollution Prevention/Good Housekeeping

### 2.6.3 Creating a Stormwater Management Strategy

After reviewing these documents, it was determined that providing a full scale SMP was not feasible for the scope of this project. In place of this, the project will seek to create a strategy for WPI moving forward to guide the school in their stormwater management efforts. The strategy should follow a format similar to that of a SMP. The following information will describe parts of a SMP that will be used as guidelines for the structure of the Stormwater Management Strategy for WPI's campus.

#### Introduction

The introduction portion of a SMP should lay out the goals of the plan. Most goals should at least hope to reduce flood damage, minimize pollutants in stormwater runoff, and educate the public about potential negative effects of stormwater runoff.

#### Existing Conditions.

This section should paint a picture for the reader of the conditions of the area the SMP will govern. This should include a discussion of the topography of the area, with a basic analysis of where all the stormwater goes. There should be a runoff analysis showing how runoff flows throughout the area. This section should also include a discussion of the existing drainage system in place and any other stormwater structures that may exist. Lastly, the condition of any receiving bodies in the area should be analyzed and discussed. (Payne, 2012)

#### Course of Action

The next portion of the plan should detail the necessary course of action to accomplish the goals of the plan. Part of these methods may include public education, where the plan seeks to educate the public about dangers associated with stormwater. Other methods could include illicit discharge control, to help limit any harmful dumping, and potentially establish programs for things such as oil recycling. Another important method, especially on growing college campuses such as WPI's, is construction site runoff control, where the plan discusses how to control erosion and pollutant discharges from any active construction sites in the area. Pollution



prevention should also be addressed, covering things such as proper maintenance of grounds to reduce potential harmful runoff (pesticides, sediment, etc.), to proper maintenance of vehicles and equipment owned, in this case, by the university. Lastly, a discussion of best management practices (BMP's) should be included. This is typically done by introducing several common structural BMP's such as rain barrels, pervious pavements, and retention ponds. This section should describe any BMP's that could potentially be implemented in the area governed by the SMP.

### **3.0 Methodology**

In order to achieve the goal of creating a Stormwater Management Strategy for WPI and then designing a BMP somewhere on campus to decrease WPI's contribution to receiving bodies, information regarding stormwater runoff on campus was acquired. This methodology section details the steps taken to reach this goal, which are as follows:

1. GIS Analysis
2. Load Analysis
3. Identification of BMP and Location
4. BMP Design
5. Analysis of BMP
6. Development of Stormwater Management Strategy

#### **3.1 GIS Analysis**

An important component of this project was the analysis of WPI's campus using ArcGIS. This analysis revealed areas of campus that were high contributors of stormwater runoff, provided a basis for identifying areas of campus with high potential for the design of a BMP. This section details the steps taken to attain these results, which included:

1. Create Base Map
2. Map Stormwater Flow
3. Identify Drainage Areas
4. Determine Impervious Areas

##### **3.1.1 Create Base Map**

The first step in analyzing WPI's campus using ArcGIS was to create a base map of the campus area. While creating the base map, it was important to keep in mind what the map would ultimately be used for: mapping flow, identifying drainage areas, and determining impervious areas. Table 2 displays the layers which were added to the map, the reason for their inclusion, and the source of these layers.

**Table 2: GIS Base Map Layers**

<b>Layer Name</b>	<b>Purpose of Layer</b>	<b>Source</b>
CENSUS2010TOWNS_POLY	Provides town boundaries for the state of Massachusetts to locate Worcester and WPI	Massachusetts Office of GIS (MassGIS)
Parcels_Dimensions	Displays parcel boundaries, including ROW width and location of Worcester Roads	City of Worcester
Buildings	Displays campus buildings, creating a map of campus/building sizes to be included for calculations of impermeable area.	City of Worcester
Campus_Asphalt	Creates map of campus/necessary for calculating impermeable area.	WPI Stormwater Mgt
Brooks_and_Streams	Displays receiving water bodies.	City of Worcester
Catch basins clip	Identifies locations of catch basins, which are necessary for determining drainage areas.	City of Worcester
Contours	Needed for predicting runoff flow	Massachusetts Office of GIS (MassGIS)

The first layer added to the map was the CENSUS2010TOWNS\_POLY layer. This layer is a shapefile created from 2010 census data, which provided town boundaries for the state of Massachusetts. The town boundaries were needed on the map for a reference point in locating WPI’s campus. The second layer added was the Parcels\_Dimensions layer, which was primarily added due to its inclusion of Worcester roads.

Once the town boundaries and parcels were in place, layers specific to WPI’s campus were added. The Buildings layer was added to the map, which provided all of the buildings in the city of Worcester. Next, the Campus Asphalt layer was added, displaying all of the paved surfaces on campus. These layers allowed us to locate the campus, but were also necessary later on in the process in determining impervious areas on campus for Simple Method calculations.

The last step was adding layers relevant to stormwater. These included the Brooks\_and\_Streams layer, which provided the water bodies in the city of Worcester. Next, the Sewer\_Lines layer was added, which revealed both sewage and stormwater sewers. The catch basins layer was added next. This would allow us to identify the stormwater sewers by their relative location to catch basins, and later assist in the identification of drainage areas. Lastly, the Contours layer was added to the map. This layer was necessary for mapping the direction of stormwater flow.

### **3.1.2 Map Predicted Stormwater Runoff Flow**

Following the creation of the base map, the flow of stormwater needed to be analyzed. To do this, the contour lines layer was utilized. Starting from high points, stormwater flow was simulated by following contours perpendicular to one another in decreasing elevations until a catch basin was reached. This was done across campus, until the whole campus was mapped out.

### **3.1.3 Identify Drainage Areas**

Once the stormwater flow was mapped out, the campus was then divided into drainage areas. These areas were determined using the predicted stormwater runoff flow map created in the previous step. Runoff flow was mapped until it reached a catch basin to determine the contributing area for each catch basin. These areas were necessary to calculate pollutant loads using the Simple Method. Drainage areas were traced using the draw tool on ArcGIS along the determined flow lines. Once these areas were traced, the draw tool provides the total areas for each determined drainage area.

### **3.1.4 Impervious Area Totals**

Lastly, impervious areas needed to be determined for simple method calculations as well. To do this, the impervious areas provided by the Buildings layer and campus Campus\_Asphalt layer were outlined using the draw tool on ArcGIS. These impervious areas were allocated to the drainage areas. The draw tool calculates the area, which was used to determine the percentage of impervious area within each drainage area.

These values were needed to complete Simple Method Calculations for each drainage area.

### 3.2 Load Analysis

In order to select a drainage area in which to design a BMP to decrease runoff volume or pollutant load, an analysis had to be completed. The simple method was chosen to compute annual runoff and resulting pollutant load of various drainage areas on campus to narrow the choices for the area most in need of a BMP. The simple method was used to estimate annual runoff and loads of nitrogen, phosphorus and total suspended solids.

#### 3.2.1 Simple Method Analysis

After the various drainage areas and impervious areas were identified, the simple method was implemented to find annual load and runoff. An excel spreadsheet was created in order to compute total phosphorus, nitrogen and suspended solids loads.

$$Rv = .05 + .9Ia \quad \text{Equation 1}$$

The first equation entered into the spreadsheet was *Equation 1* (above). Rv (runoff coefficient) was found through the use of Ia (Impervious area percentage), which was measured during the GIS analysis of each area. Rv was then used in *Equation 2* (below) in order to calculate annual runoff in inches (R).

$$R = P \times Pi \times Rv \quad \text{Equation 2}$$

In this Equation 2, P (annual precipitation) was determined to be 48.1 inches from the U.S. Climate Database for Worcester, Massachusetts. Pi (percentage of rainfall events that produce runoff) was entered as 0.9 as that is the national average (Stormwater Center). After R was calculated for the various contributing areas on campus, total phosphorus, nitrogen and suspended solids were then calculated using *Equation 3* (below).

$$L = 0.226 \times R \times C \times A \quad \text{Equation 3}$$

This equation was entered into the spreadsheet for each section in order to calculate individual pollutant load. A (area) was taken from the GIS analysis and entered in the

spreadsheet for each individual contributing area in acres. The C value was dependent on land use and pollutant type being calculated. These C values were taken from Table 1, Table 2 and Table 3 from the Storm Water Center, compiled from various case studies completed by the NRCS, EPA and other stormwater management studies. The GIS file as well as Google Earth were used to determine the land use and acreage for each contributing area. Then total C values were determined for each of the three pollutants for each contributing area based on percentages of land use.

After the total loads for each contributing area were found, the areas with the highest total loads were selected and further analyzed in their feasibility to install a BMP in section 3.3.

### **3.3 Identification of BMP Location**

To determine the location of the BMP to be designed, the Simple Method Load calculations were consulted. Areas producing high pollutant loads were focused on, especially TSS loads, due to reported high loads of TSS in Salisbury Pond, in an effort to decrease WPI's contribution to this ongoing problem. Using this criteria, the three highest contributing areas of TSS were analyzed further. To analyze these loads further, the annual loads of TSS per acre were determined for these areas. With this data, an area could be selected that would allow for the design of a BMP to remove a high level of pollutants while treating a relatively low volume of water, increasing the potential use of different BMP's as high runoff volumes would become less of a concern.

### **3.4 Evaluation of BMP's**

In order to select a BMP to be developed on the WPI campus, an analysis of various BMP's had to be completed. The BMP's selected for analysis were the tree box filter, permeable pavement, rain gardens, bioswales, and rain barrels. Each BMP was compared on price per square foot, total suspended solids removal efficiency, total nitrogen removal efficiency, total phosphorous removal efficiency and feasibility to

be designed in the selected problem area. These values were inputted into a table found in the results and a selection was made based on the findings.

### **3.5 BMP Design**

It was ultimately decided to plan for the design and installation of a tree box filter. The design was based on one of the best available on the market, a Filterra bio-retention system, so that load removal calculations would be similar as building and testing a prototype would not be feasible. After determining the size of the unit that was to be designed, finding a location required us to survey a section of the library driveway where it was decided the BMP could be implemented. The data needed to show that there was a downward slope where the tree box filter was to be designed with an existing bypass system in the form of an existing catch basin. The elevations obtained in the survey were true elevations using a known benchmark on the Kaven Hall grounds. The results of the surveying can be found in Appendix B. A working model of the tree box filter was designed in AutoCAD and the model was used in Revit to create a mock of the design site.

### **3.6 Analysis of BMP**

In order to measure the pollutant reduction that the Filterra Tree Box Filter would have on the drainage area it will be installed into, a quantitative analysis was completed. A table was made calculating the amount reduced and new pollutant load for the drainage area. The pollutant loads calculated from the simple method for total suspended solids, total nitrogen and total phosphorous were used as baseline data to calculate the new load of said pollutants. Pollutant reduction numbers were found from the Filterra website and based on numerous field tests.

### **3.7 Developing a Stormwater Management Strategy for WPI's Campus**

Creating a Stormwater Management Strategy for WPI's campus was an important part of this project. While WPI is not the only contributor of runoff to its receiving water bodies, we should aim to minimize the impact we have. Through the creation of a SMP, goals can be set to accomplish this.

The first step in the creation of a stormwater management strategy for WPI was establishing the primary goals. Goals typically aim to decrease the contribution of runoff, especially runoff containing high concentrations of pollutants. A set of goals were created, with the primary intent of increasing public awareness and decreasing the concentration of pollutants entering Worcester's stormwater infrastructure.

Next, an overview of existing conditions on campus is provided. Here, the plan describes the topography and physical characteristics of campus, along with the current drainage system on and around campus. A GIS map of the area will be created to help portray the current conditions more clearly.

Next, the plan discusses methods utilized to help reach the goals of the plan. A section about illicit discharge control on campus was created, primarily addressing the harmful effects of illegal dumping, and potential methods to decrease the frequency of these activities. This was done to help WPI be consistent with the "Keep Worcester Clean" initiative of 2004, part of which placed an increased emphasis on the elimination of general littering, and specifically illegal dumping in the city (Worcester, 2004). Since WPI is a continuously growing campus, a section regarding control of construction site runoff was also created, to ensure any construction on campus limits any potential negative effects of stormwater runoff from the construction site. Lastly, a section detailing common BMP's that could potentially be implemented on campus was created. The BMP's described in this section are ones that are often utilized in urbanized and highly developed areas, like WPI's campus.



## 4.0 Results and Analysis

As the methods described in chapter 3 were completed, the results were analyzed to continue progressing towards reaching the goals of this project. In this chapter, these results will be presented. A brief analysis of the impact of these results on the progress of the project will be provided, to portray the thought process and reasoning of decisions as the project progressed.

### 4.1 GIS Analysis

The purpose of the GIS analysis was to determine flow patterns, and gain an understanding of the contribution of pollutants from each drainage area. This chapter will detail the results of each major step of this GIS analysis by displaying the maps created, and the data obtained from these maps.

#### 4.1.1 Base Map

Figure 1 below is a screenshot of the base map created using ArcGIS. Seven GIS layers were combined to create the map, which was used to predict stormwater runoff flow, identify drainage areas, and determine impervious areas within each drainage area.

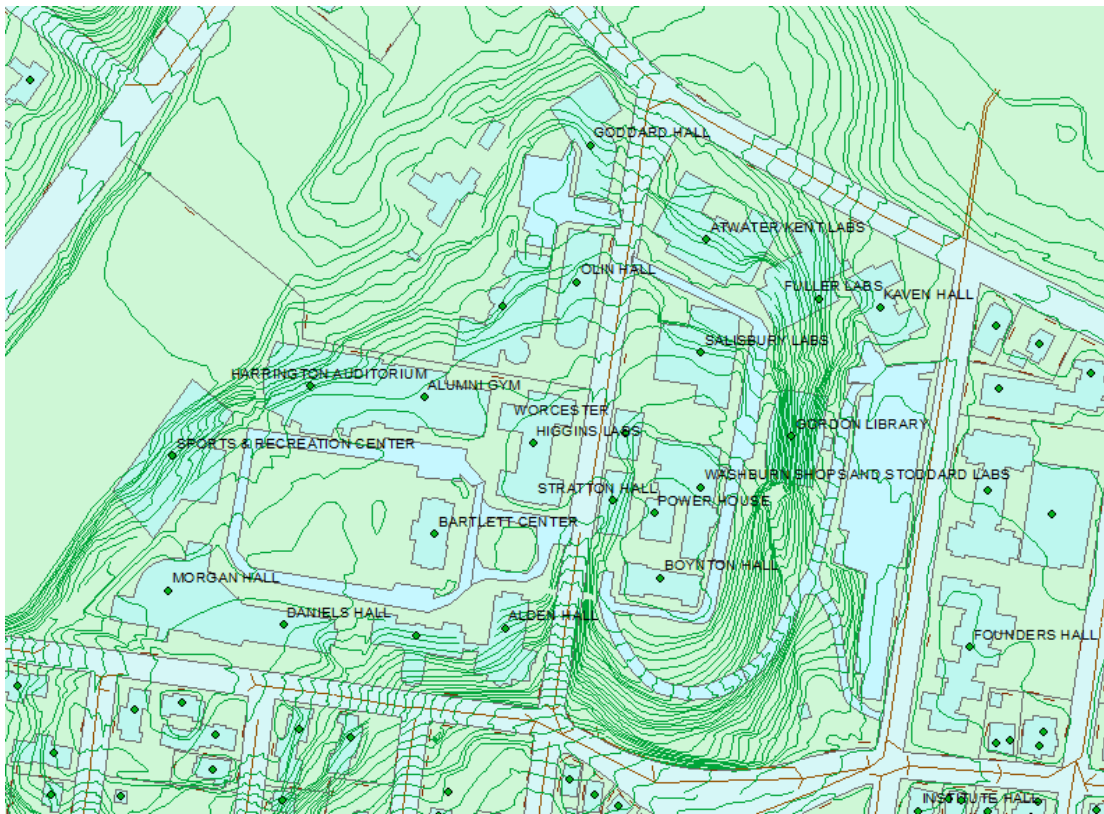

Figure 1: ArcGIS Base Map

#### 4.1.2 Flow Analysis

Figure 2 below is a screenshot of the predicted flow of stormwater runoff using the ArcGIS base map. The black arrows represent predicted flow of stormwater runoff. The flow patterns were predicted until the runoff would be collected by a catch basin.

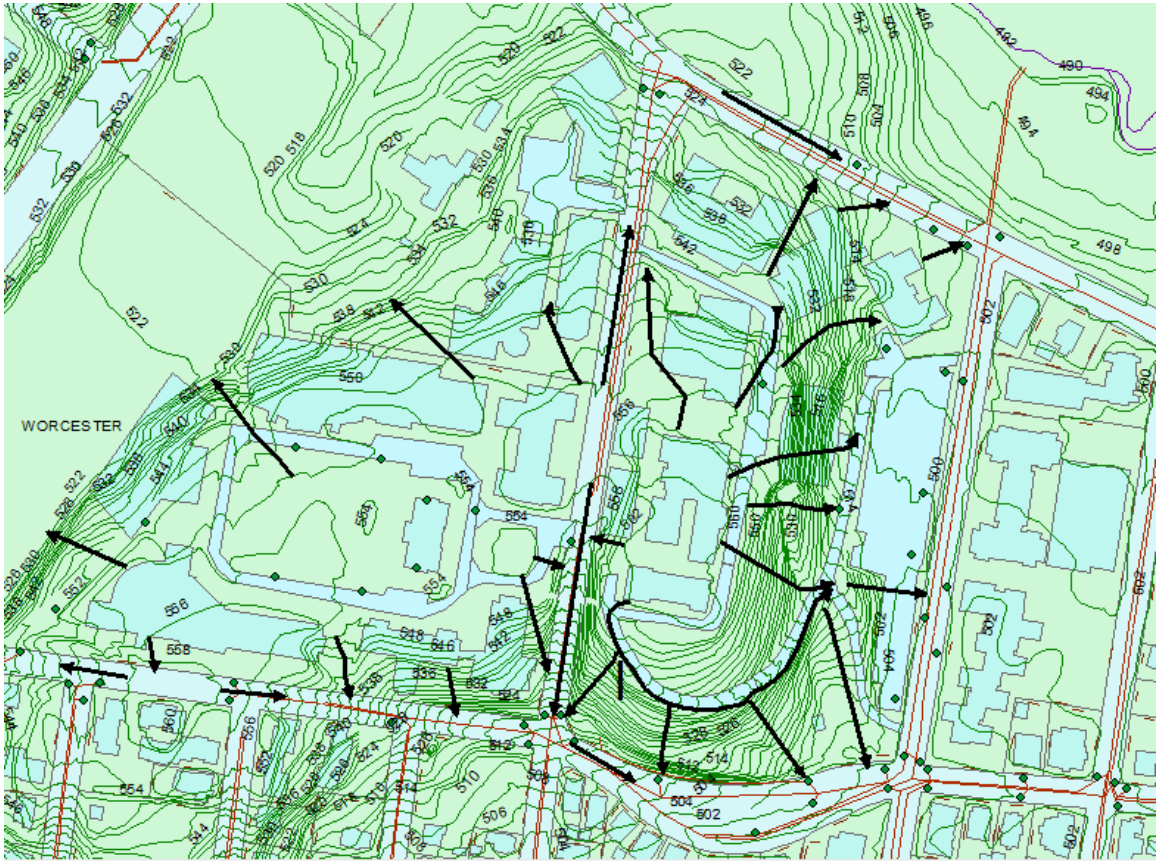

Figure 2: Flow Analysis Map

### 4.1.3 Drainage Areas Determined

Figure 3 below displays the drainage areas determined using the predicted flow patterns. Each drainage area represents the contributing area for individual catch basin.

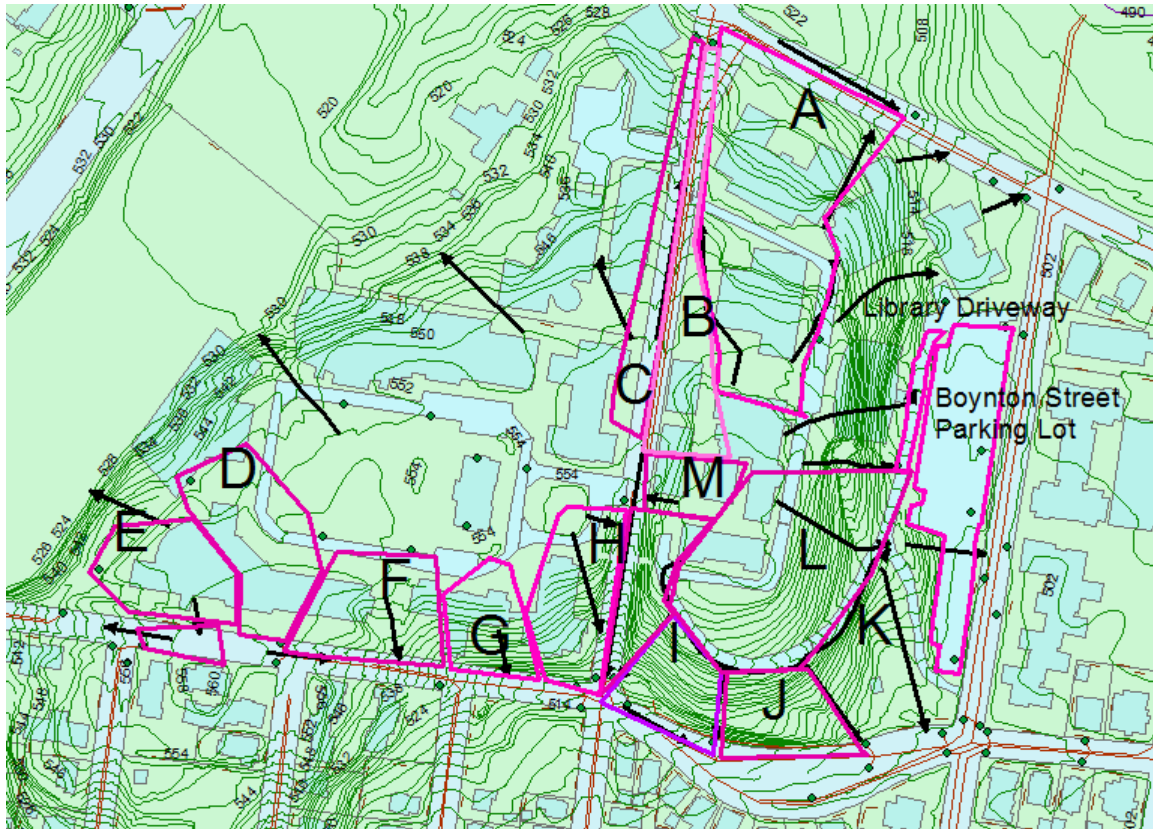

Figure 3: Drainage Areas

These drainage areas were determined so that a load analysis could later be provided for each area using the Simple Method. To perform this analysis, the total area of each drainage area was required. Table 3 below displays these values.

**Table 3: Drainage Areas Total Areas**

Section	Total Area (acres)
A	3.12
L	2.22
K	0.919
J	0.672
I	0.627
H	0.899
G	0.562
F	0.954
Boynton St. Lot	1.44
Library Driveway	0.918

#### 4.1.4 Impervious Areas

The last step of the GIS analysis was determining the amount of impervious area within each drainage area. Table 4 below displays these values for each drainage area. These values were used to calculate the pollutant loads of each drainage area using the Simple Method.

**Table 4: Impermeable Areas of Drainage Areas**

Section	Impermeable Area (acres)	Percentage Impermeable Area
A	1.20	38.50%
L	0.674	30.27%
K	0.094	10.20%
J	0.102	15.23%
I	0.120	19.17%
H	0.486	54.02%
G	0.189	33.74%
F	0.213	22.33%
Boynton St. Lot	1.44	100.00%
Library Driveway	0.213	23.20%

#### 4.2 Load Analysis

After the Simple Method calculations were completed using a Microsoft Excel spreadsheet, Table 5 was made displaying annual load of Total Suspended Solids (TSS), Phosphorus (P) and Nitrogen (N) for each section initially selected from GIS.

The simple method calculated annual loads based on total area and impermeable area percentage, as well as type of surface layer and annual precipitation. This data was used to help determine the areas of concern on campus.

*Table 5: Annual Pollutant Loads*

Section	Annual TSS Load (Lb)	Annual P Load (Lb)	Annual N Load (Lb)
Library Driveway	2117.1	2.4	23.0
A	5512.4	19.4	87.3
L	3705.8	12.9	56.1
K	835.1	2.9	12.5
J	776.5	2.7	11.5
I	835.0	2.9	12.3
H	1755.2	6.2	27.6
G	927.1	3.3	15.0
F	1301.2	4.6	20.4
Boynton St. Lot	424.8	2.4	29.9

### 4.3 Identification of BMP Location

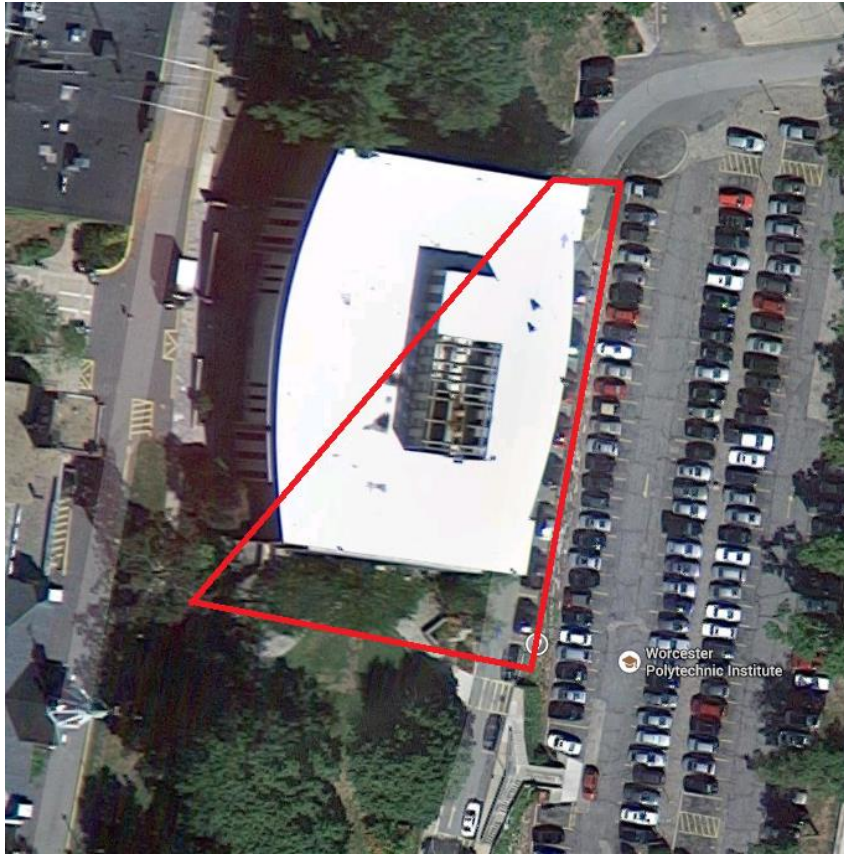

*Library Downhill Drive Drainage Area*

Looking at Table 5, the three highest loads of TSS were produced by the library driveway lot, lot A, and lot L. Looking a bit closer, however, the library driveway produces the highest amount of TSS per acre, making it the most concentrated contributor of TSS of the three. Table 6 below displays the loads per acre for lots A,L, and the library driveway. This was an important factor to look at, as Salisbury Pond (the receiving water body of all three of these areas) has been documented as having high concentrations of TSS. By focusing on the library driveway for the design of a BMP, similar results of TSS removal can be achieved while treating smaller volumes in comparison to lots A and L. The image above displays the library driveway area, outlined in red. A portion of the library roof was included, as information regarding the runoff from stormwater gutters was not available.

**Table 6: Pollutant Loads per Acre**

Section	Annual TSS Load per Acre	Annual P Load per Acre	Annual N Load per Acre
Library Driveway	2306.2	2.6	25.1
A	1766.8	6.2	28.0
L	1669.3	5.8	25.3
Boynton St. Lot	295.0	1.7	20.8

**4.4 Evaluation of BMP’s**

Based upon the selection of the Library Driveway Lot only three of the BMP’s analyzed (shown below in table 7) were deemed feasible because of the majority of the lot’s area being impervious surfaces. Because of the impervious surfaces, rain gardens and bioswales could not be implemented in this area. The rain barrels were also ruled out because they could not be beneficial in their primary use of water reuse with WPI’s large water usage rate. Based upon price per square foot and estimated pollutant removal, ultimately the tree box filter was chosen over the permeable pavement. The MQP completed last year, *WPI Stormwater Management Plan and Design of Permeable Pavements for Runoff Reduction*, determined that permeable pavement was not cost effective in a larger area than the Library Driveway Lot making it even less cost effective in the selected lot (WPI, 2014). With all these factors considered the tree box filter was chosen.

**Table 7: BMP Analysis**

BMP Type	Cost /square ft.	TSS Removal Efficiency	TN Removal Efficiency	TP Removal Efficiency	Feasibility with Library Drive
Tree Box Filter	\$.55-\$.70	85%	43%	65%	Yes
Permeable Pavement	\$5-\$10	82-95%	80-85%	65%	Yes
Rain Garden	\$2-\$8	80-90%	70-80%	75-85%	No
Bioswales	\$.10-\$.50	80%	70%	75%	No
Rain Barrels	\$20-\$150 * per barrel	N/A	N/A	N/A	Yes

\*Data from the table was obtained from the Lincoln Nevada Publics Works, Low Impact Development and The Center for Watershed Protection Maryland

#### 4.5 BMP Design

Our resulting BMP design was a concrete tree box filter that would be made out of precast concrete. The unit would be in two main pieces the base and a top that set into the base with a 1-inch interlocking joint. There is also a 2 piece grate on the top that is made of two symmetrical cast iron plates and is 3'x3'. All dimensions can be seen on the drawings found, in Appendix C. The box filled with a bottom layer of underdrain stone, which surrounds a perforated PVC pipe, serving as the underdrain system. On top of the stone goes a bio filtration material, which can effectively remove pollutants. The design is simple and effective, typically estimated to cost about \$7500/unit (Filtterra, 2014) and easily maintained for less than \$500 a year. Installed, the tree box filter is set parallel to the roadway with the bottom of the throat opening at street level Figure 4, shown below, displays a rendering of what the installed tree box filter would look like on site, including the adjacent catch basin, necessary as an effective bypass system.

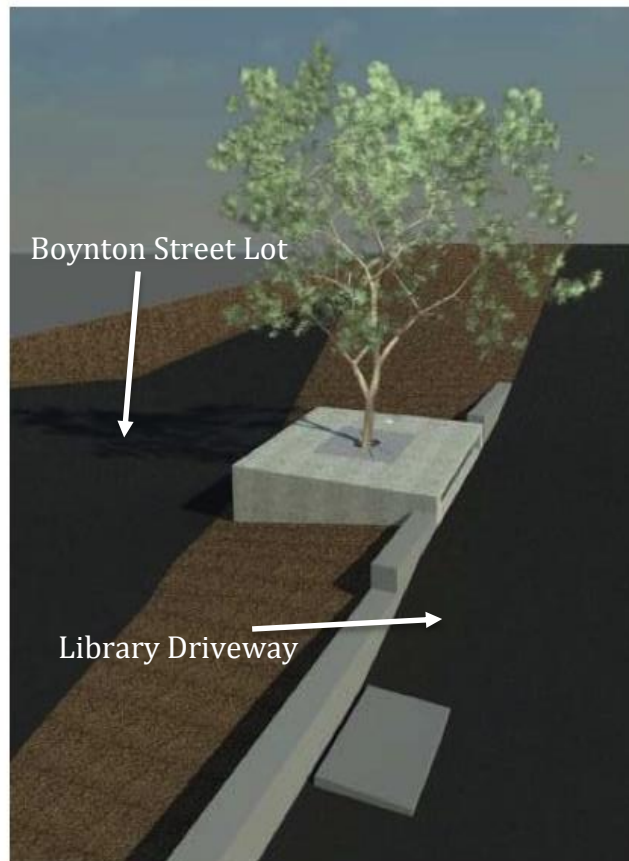

Figure 4: Tree Box Filter Site Rendering



#### 4.6 Analysis of Tree Box Filter

In order to accurately measure the effectiveness of the tree box filter, an analysis was completed using third party reported removal rates of TSS, total phosphorus, and total nitrogen for the Filterra Bio-Retention system. The reported removal rates were 85% of TSS, 65% of total phosphorus, and 43% of total nitrogen. These removal rates were applied to the loads calculated using the Simple Method for the library driveway area to determine the predicted annual reduction totals, and predicted annual loads following the installation of the tree box filter. The Filterra engineered media is specially designed to operate under high flow rates, up to 100-140 inches/hour. Table 8 below displays the expected results of the tree box filter's pollutant removal.

	<b>TSS</b>	<b>Phosphorus</b>	<b>Nitrogen</b>
<b>Initial Load (lb./yr.)</b>	2117.1	2.4	28.0
<b>Amount reduced (lb./yr.)</b>	1799.5	1.5	12.1
<b>New Load (lb./yr.)</b>	317.5	0.8	15.9

*Table 8: Filterra Removal Rates*

#### 4.7 Stormwater Management Strategy for WPI's Campus

A Stormwater Management Strategy was created for WPI's campus as a part of this project. This strategy was created with the intent to provide examples of proper stormwater management techniques, decrease the concentration of pollutants in runoff entering the city's stormwater infrastructure, and increase the WPI community's knowledge of proper stormwater management practices. To achieve this, the EPA's six minimum control measures were considered. The Stormwater Management Strategy for WPI's campus is presented in Appendix D. The remainder of this section will provide a brief summary of each chapter of the document.

#### 4.7.1 Introduction and Goals

This chapter is intended to introduce the purpose of the stormwater management strategy, and present its overall goals. The stormwater management strategy is intended to serve as an initial step at WPI towards improving the quality of stormwater management on campus. To achieve this, the following goals were created:

- Provide examples of proper stormwater management techniques.
- Decrease the concentration of pollutants in runoff entering the city of Worcester's stormwater infrastructure.
- Increase the WPI community's knowledge of proper stormwater management practices.

#### 4.7.2 Existing Conditions

In order for the remainder of the document to be relevant, an overview of WPI's campus and the existing stormwater management conditions is presented in this chapter. Totalling approximately 80 acres, WPI's campus sits atop Boynton Hill. Stormwater runoff from the campus is gathered by the city of Worcester's stormwater infrastructure. Figure 2 below displays a map of the campus, including the predicted flow of stormwater runoff. A significant amount of this runoff is eventually discharged into Salisbury Pond in Institute Park. The pond is listed on the 303d list for Nuisance Aquatic Plants and Turbidity associated with high phosphorus loadings.

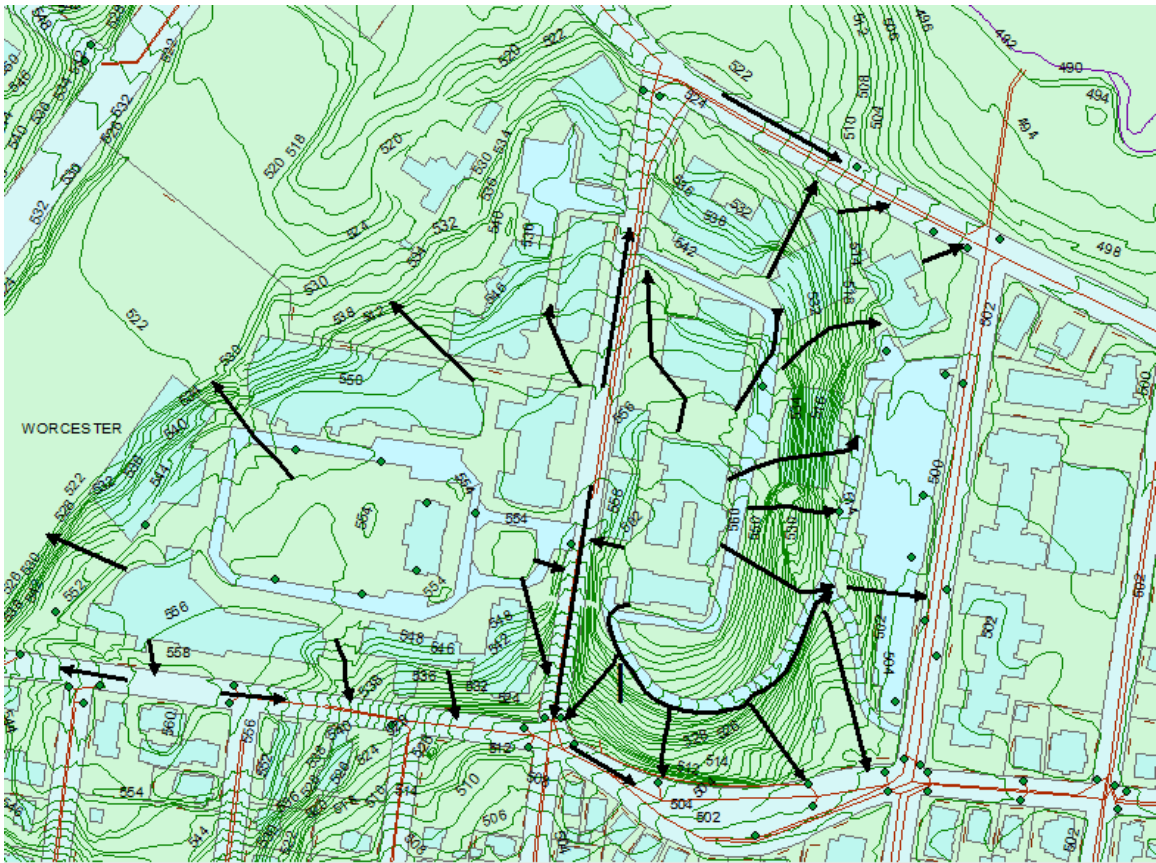

Figure 2: Flow Analysis Map

#### 4.7.3 Public Education

One of the goals of this strategy was to increase the WPI community's knowledge of proper stormwater management practices. The challenge faced in achieving this goal is that most people are not fully informed of the potential harm that can be caused by pollutants in stormwater runoff. To combat this problem, this chapter provides the reader with an overview of stormwater runoff, and the dangers associated with it.

#### 4.7.4 Public Involvement and Participation

In order to effectively improve the quality of stormwater management, cooperation amongst the public is required. To achieve this, public participation must be encouraged. This chapter presents an opportunity to promote public involvement

through education. WPI has at its disposal a wealth of knowledge on the topic of stormwater management between both its students and professors. To take advantage of this knowledge, a Stormwater Management Improvement group should be created within the civil and environmental engineering department. This group could host seminars on campus to promote proper stormwater management techniques and address everyday activities that could be harmful to receiving water bodies, such as littering, washing cars, and changing motor oil. Aside from these everyday activities, the group could also present progressive stormwater BMP's to prospective civil engineers, who could one day be in a position to implement these practices.

#### **4.7.5 Illicit Discharge Control**

Illicit discharges are considered to be any discharge to a stormwater sewer system that is not composed of only stormwater. Most of these discharges are cases of illegal dumping into catch basins, or directly into water bodies. This chapter is designed to help decrease the frequency of such occurrences in the campus area. Common methods of combatting these problems includes increased signage near catch basins, warning potential offenders of the fines associated with such activities. A more aggressive approach would include the creation of a hotline allowing citizens to report sightings of illegal dumping activities.

#### **4.7.6 Construction Site Runoff Control**

As a growing university, construction is a frequent occurrence on WPI's campus. With this construction comes an increased potential for sediment and pollutants to be carried in stormwater runoff into the city's drainage system. Because of this, certain precautions must be taken to minimize any additional harm to receiving water bodies.

The National Pollutant Discharge Elimination System (NPDES) permit program requires construction sites disturbing one or more acres of land to obtain coverage

under a NPDES permit for their discharges. The construction site operators must abide by the EPA Construction General Permit. This permit places both numeric and non-numeric effluent limitations for the site operator to abide by.

#### **4.7.7 Post Construction Runoff Control**

After construction is completed, these sites can still present potentially high levels of sediment and pollutants that can be gathered in runoff. In accordance with NPDES requirements, MS4 operators are required to address post construction runoff from new development through the developments of strategies which incorporate stormwater BMP's. Since WPI has shown to be forward thinking in recent history in terms of incorporating stormwater BMP's in their designs, such as the green roof on East Hall, it should be encouraged to continue this trend of including stormwater BMP's in future construction designs.

#### **4.7.8 Pollution Prevention**

As a college campus, there are a number of activities that take place every day which could potentially increase the level of pollutants in stormwater runoff leaving campus. This chapter is designed to address these activities, by suggesting the incorporation of stormwater training with general safety training provided to the facilities department.

#### **4.7.9 Best Management Practices**

To have a direct effect on the improvement of stormwater runoff quality, BMP's should be continuously explored for implementation on campus. This chapter was created to present a few of these BMP's. An overview of permeable pavements, tree box filters, and rain barrels is presented, as these are three BMP's that are often utilized in highly developed areas such as WPI's campus.

## 5.0 Conclusions

For this project a BMP was selected and designed for to reduce pollutant loads entering Worcester's stormwater infrastructure from WPI's campus. The best management practice designed was a tree box filter because of the compatibility of the location, Library downhill drive, and its effectiveness in the removal of pollutants. Because of the driveway's proximity to a grassy hill the estimated pollutant levels from the drainage area were high; annually 2117 lbs of total suspended solids, 2.36 lbs of phosphorous and 28.03 lbs of nitrogen. The installed tree box filter is expected to reduce the annual loads of total suspended solids by 1800 lbs, phosphorous by 1.5 lbs and nitrogen by 12 lbs, helping to decrease the pollutant loads entering Salisbury Pond annually.

This project also created a stormwater management strategy for WPI's campus. This strategy sought to effectively increase awareness of proper stormwater management practices, and decrease the concentration of pollutants in stormwater runoff entering stormwater infrastructure. To accomplish these goals, the document addressed the six minimum control measures as defined by the EPA: public education, public involvement and participation, illicit discharge control, construction site runoff control, post construction runoff control, and pollution prevention. This stormwater management strategy can provide a basis to move forward from in placing an increased level of importance on improving the quality of stormwater management on WPI's campus.

## Works Cited

2004, February. *Computing Stormwater Runoff Rates and Volumes* (n.d.): n. pag. Web.

"Authorization Status for EPA's Stormwater Construction and Industrial Programs." *Home*. N.p., n.d. Web. 16 Oct. 2014.

"Convocation Week at the University of Pennsylvania." *Science* 20.522 (2013): n. pag. Web.

"Cost Slide." *Economic and Political Weekly* 40.16 (2005): 1572-573. Web.

Commonwealth of Massachusetts. "Total Maximum Daily Loads of Phosphorus for Salisbury Pond." (2002): n. pag. Print.

Debo, Thomas N., Andrew J. Reese, and Thomas N. Debo. *Municipal Stormwater Management*. Boca Raton, FL: Lewis, 2003. Web.

Effective Beginning With The January 2014 Examinations. *Fundamentals of Engineering (FE) CIVIL CBT Exam Specifications* (n.d.): n. pag. Web. 22 Mar. 15.

"EPA." *National Stormwater Calculator*. N.p., n.d. Web. 16 Oct. 2014.

Houyou, Amanda, and Robert Medaglio. "WPI Stormwater Management Plan and Design of Permeable Pavements for Runoff Reduction." 1 Jan. 2014. Web. 20 Apr. 2015.

"JRA Cost Effectiveness Full Report." Web. 24 Apr. 2015.

Kowalsky, Greg, and Kathryn Thomason, P.E. "Cistern Design Considerations for Large Rainwater Harvesting Systems." *PDH Article* -. N.p., n.d. Web. 27 Apr. 2015.

Licensure *Why Get Licensed?* NPEES., n.d. Web. 22 Mar. 15.

"LID Urban Design Tools - Tree Box Filters." *LID Urban Design Tools - Tree Box Filters*. Web. 24 Apr. 2015.

"Lincoln Nebraska Public Works BMP Guide." Web. 24 Apr. 2015.

Management, Division Of Watershed, Wetlands And Waterways Program, and March 2002. (n.d.): n. pag. Web.

Minervini, William P. "Of: Sustainable Oil and Grease Removal from Synthetic Stormwater Runoff Using Bench-Scale Bioretention Studies, E. Hong; E. A. Seagren; A. P. Davis, 78, 141—155 (2006)." *Water Environment Research* 79.4 (2007): 447-48. Web.

*Phase II Stormwater Management Plan, Millis, MA*. Milford, MA: Comprehensive Environmental, 2003. Web.

"Pollutants in Stormwater Runoff." *Pollutants in Stormwater Runoff*. N.p., n.d. Web. 16 Oct. 2014.

"Proposed National Rulemaking to Strengthen the Stormwater Program." *Home*. N.p., n.d. Web. 16 Oct. 2014.

"Rational Equation Calculation,  $Q=ciA$ ." *Rational Equation Calculation,  $Q=ciA$* . N.p., n.d. Web. 16 Oct. 2014.

*Soil Survey of Worcester County, Massachusetts, Northeastern Part*. Washington, D.C.: Service, 1985. Web.

"Stormwater Homepage." *Home*. N.p., n.d. Web. 16 Oct. 2014.

"Stormwater Management Best Practices." *EPA*. Environmental Protection Agency, n.d. Web. 16 Oct. 2014.

"Stormwater Management Plan Template". Payne, Linsey, University of Oregon *The Case for Environmental Regulatory Reform Clean Water Act NPDES Permitting* (n.d.): n. pag. Web.

"The Simple Method to Calculate Urban Stormwater Loads." *The Simple Method to Calculate Urban Stormwater Loads*. Web. 24 Apr. 2015.

*Total Maximum Daily Loads of Phosphorus for Salisbury Pond* (n.d.): n. pag. Web.

Us Epa, Region 1, Assistance And Pollution Prevention Office. *Best Management Practices for Colleges and Universities: Water Management: Parking Lot Storm Water Control Program, Boston University, Updated January 2007* (n.d.): n. pag. Web.

"Use of the Rational and Modified Rational Methods for TxDOT Hydraulic Design". Cleveland, Theodore G., David B. Thompson, Xing Fang, and William H. Asquith. Lubbock, TX: Center for Multidisciplinary Research in Transportation, Texas Tech U, 2011. Web.



Usepa, Region 1, Office Of Site Remediation And Restoration. *Permit No. MAS010002: Authorization to Discharge under the National Pollutant Discharge Elimination System* (n.d.): n. pag. Web.

Water, Us Epa Office Of. *Urban Storm Water Preliminary Data Summary* (n.d.): n. pag. Web.

Worcester Municipal Separate Storm Sewer System (MS4) (NPDES Permit Number MAS010002) | NPDES Permits in New England | US EPA." *EPA*. Environmental Protection Agency, n.d. Web.

## Appendices

### Appendix A: Stormwater Management on WPI's Campus Project Proposal



## Stormwater Management on WPI's Campus MQP Proposal

By Brian Marsh, Ian McMullen, and Jacob Grills

Advised by Suzanne LePage and Paul Mathisen

## Table of Contents

1.0 Introduction.....	
2.0 Background.....	
2.1 Stormwater.....	
2.2 Stormwater Management Plans.....	
2.3 ArcGIS.....	
2.4 Massachusetts Stormwater Regulations.....	
2.4.1 Municipal Separate Storm Sewer System.....	
2.4.2 Salisbury Pond.....	
2.5 Flow and Load Quantification Methods.....	
2.5.1 Rational Method.....	
2.5.2 Modified Rational Method.....	
2.5.3 Simple Method.....	
3.0 Methodology.....	
3.1 GIS Analysis and Identification of Areas of Concern.....	
3.2 Flow and Load Quantification.....	
3.3 Creation of Stormwater Management Plan for WPI.....	
3.4 Design of BMP.....	
<b>3.5 Tentative Schedule of Project Work to be Done.....</b>	

## Introduction 1.0

Stormwater runoff creates major problems in our ponds, lakes and rivers because of the high amount of chemicals and sediments it contains as it is not treated before it enters the water body. With such a delicate ecosystem, these bodies of water can not handle the stress that stormwater runoff pollutants bring. (EPA, 2014). These pollutants build up in the water and cause problems for aquatic life. Sediments and fertilizers from residential runoff can cause water turbidity and excess nutrient growth decreasing the amount of oxygen available in the water. Pollutants from automobiles such as oil and antifreeze are toxic to wildlife and can make waters unsafe for recreational use. (Clean Water Education Partnership, 2013).

Located adjacent WPI, Salisbury Pond is home to a large portion of the institute's stormwater runoff. Much of the water that enters the pond is unfiltered and contains the pollutants it collects from our campus and the streets of Worcester. With very high impervious surface rate on campus there is a very high flow and pollutant concentration as well. Very few Best Management Practices are in place to reduce and filter the flow of stormwater into the pond which should be a priority for the institute. Ideally most of the water would infiltrate into the soil before entering the pond.

Currently WPI does not have an official stormwater management plan and is regulated by the city of Worcester's MAS010002, an EPA permit for MS-4 discharge of stormwater. However, many of the requirements are not being met, highlighting WPI's need for a new plan. The goal of this project is to provide WPI with a

stormwater management plan based on the following goals: A GIS analysis of the drainage system to determine areas with heavy amounts of runoff, a flow and load calculation of the selected problem areas, a new stormwater management plan outline as well as table comparing the best management practices. After completing these goals we will design our selected BMP for the capstone design element of this project.

## 2.0 Background

In this section, background information will be presented that will be helpful in understanding the goals and steps of this project. An overview of stormwater itself will be given, along with background information in regards to tools that will be utilized throughout the project. One of the key components of this project is the creation of a Stormwater Management Plan for WPI. To provide a better understanding of what it is this project will accomplish with this, an overview of stormwater management plans will be presented as well.

### 2.1 Stormwater

Stormwater is water collected on the ground from either rain or snow. In an ideal environment stormwater would slowly infiltrate into the soil and naturally filter away pollutants before entering a water body. With the current development in our cities, impervious surfaces such as roads, sidewalks and buildings speed up the water's path to a waterbody. Since the stormwater is not allowed to penetrate the surface, it enters the waterbody unfiltered with any pollutants it collects.

## Comparing runoff between pervious and impervious surfaces

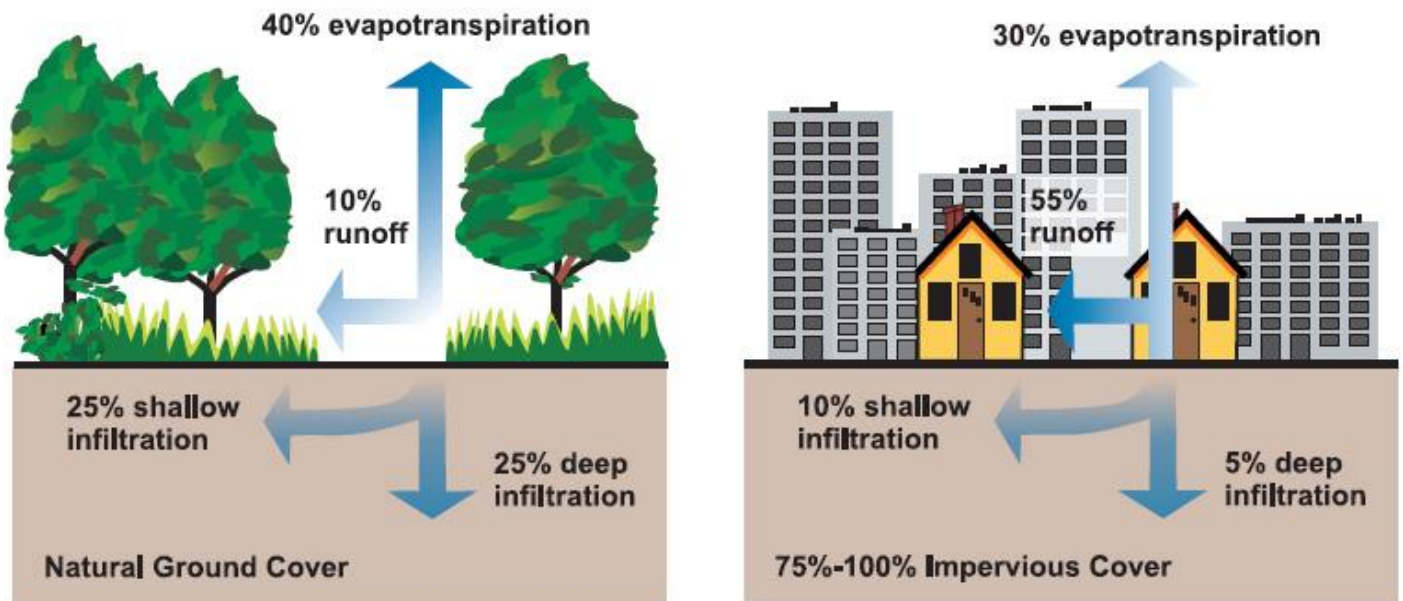

When the unfiltered stormwater enters the waterbody many pollutants such as sediments, excess nutrients, household hazardous waste, debris and pathogens enter the ecosystem. Sediments cloud the water, making it difficult for aquatic plants to grow as well as destroy aquatic habitats.(Lake Superior Streams, 2011). Excess nutrients, phosphorus and nitrogen, can cause algae blooms which decrease oxygen levels causing aquatic life to suffer. Household wastes like pesticides, insecticides and motor oil can poison aquatic life when entered into the water system.(EPA, 2014). Without any infiltration into the ground these pollutants enter and disrupt the natural balance.

## 2.2 Stormwater Management Plans

Stormwater management plans (SMP's) have become more and more common throughout the country. Stormwater management is increasingly becoming a concern for the EPA, as they are even beginning to offer incentives and assistance to communities to help them implement strong stormwater programs. (EPA, 2013) These plans create an opportunity for municipalities to be more effective in controlling their stormwater runoff by allowing them to clearly define what their goals are, and the necessary actions to work toward these goals. (Yale, 2013) The structure of SMP's can vary tremendously depending on the area it is being created for. In this section, information describing parts of an SMP that will be relevant to this MQP will be given. These sections have been determined by studying manuals created to aid in the creation of SMP's, along with studying existing SMP's of several universities. The relevant sections are as follows:

### Introduction

The introduction portion of a SMP should lay out the goals that hoped to be accomplished through the implementation of the plan. Most goals should at least hope to reduce flood damage, minimize pollutants in stormwater runoff, and educate the public about potential negative effects of stormwater runoff.

### Existing Conditions.



This section should paint a picture for the reader of the conditions of the area the SMP will govern. This should include a discussion of the topography of the area, with a basic analysis of where all the stormwater goes. There should be a runoff analysis showing how runoff will flow in the area. This section should also include a discussion of the existing drainage system in place and any other stormwater structures that may exist. Lastly, the condition of any receiving bodies in the area should be analyzed and discussed. (Payne, 2012)

### Methods

The next portion of the plan should detail the methods that will be used to accomplish the goals of the plan. Part of these methods may include public education, where the plan seeks to educate the public about dangers associated with stormwater. Other methods could include illicit discharge control, to help limit any harmful dumping, and potentially establish programs for things such as oil recycling. Another important method, especially on growing college campuses such as WPI's, is construction site runoff control, where the plan discusses how to control erosion and pollutant discharges from any active construction sites in the area. Pollution prevention should also be addressed, covering things such as proper maintenance of grounds to reduce potential harmful runoff (pesticides, sediment, etc.), to proper maintenance of vehicles and equipment owned, in this case, by the university. Lastly, a discussion of best management practices (BMP's) should be included. This is typically done by introducing several common structural BMP's such as rain barrels, pervious pavements, and retention ponds. This section should describe any BMP's that could

potentially be implemented in the area governed by the SMP.

## 2.3 ArcGIS

ArcGIS is a mapping tool that will be utilized throughout the project. ArcGIS consists of many different maps of a certain area with data attached to it. These maps can be combined as different layers to form a complete map of an area with whatever data attached that is necessary for your purpose. WPI has a GIS database available for our use, which will aid us in an analysis of current drainage structures and the campus as a whole.

GIS can be a very useful tool for stormwater management. It is regularly used to monitor existing stormwater management practices. Aside from this, GIS can help locate areas of concern and areas for the potential implementation of BMP's. This is done through the use of base layers (topography, water bodies) and a current stormwater management practices layer (includes current drainage structures in place). Utilizing these GIS maps, areas of concern and potential areas for the implementation of BMP's can be located. (esri, 2006)

## 2.4 Massachusetts Stormwater Regulations

In Massachusetts NPDES permits are issued by EPA New England. Meaning that unlike other states, Massachusetts did not assume the NPDES program from the federal government and the state cannot issue its own permits. Worcester was issued NPDES Permit MAS010002 for discharging storm water from its municipal separate storm sewer system (MS4), which became effective on October 30, 1998. The permit expired five years later on October 30, 2003; however, EPA administratively continued the permit as allowed by regulation.

Generally, the permit enhances the best management practices required to reduce stormwater pollutant loadings from Worcester's MS4 system. As required by regulation, these BMPs are based on measures to reduce pollution to the maximum extent practicable and to attain state water quality standards. The permit also requires wet-weather and dry-weather monitoring of the outfalls and receiving waters as well as updating the city's Stormwater Management Program. Referenced in this permit is also the state developed handbook to govern the states' stormwater regulations so whether an area has a permit yet or not they have state guidelines to follow.

In 1996, the Massachusetts Department of Environmental Protection (MassDEP) issued the Stormwater Policy; this policy established Stormwater Management Standards. The goal was to encourage recharge and prevent stormwater discharges from causing or contributing to the pollution of the surface waters and groundwaters

in Massachusetts. In 1997, MassDEP published the Massachusetts Stormwater Handbook as guidance on the Stormwater Policy. The policy is not a requirement but meant to be used as a tool along side the permit. The EPA permit still governs all stormwater laws.

## 2.4.1 Municipal Separate Storm Sewer System

MS4 stands for "municipal separate storm sewer system." It is a drainage system owned by a municipality intended to carry only surface runoff such as storm water. A separate sewer is not intended to, nor should it, carry storm water combined with sanitary sewage or with any other pollutant. A drainage system is automatically regulated if:

- The system discharges at one or more a point sources,
- The drainage system is a separate storm sewer system (not designed to carry combined storm water and sanitary waste water),
- The drainage system is operated by a public body,
- The drainage system discharges to the Waters of the United States or to another MS4, AND
- The drainage system is located in an "Urbanized Area".

In the Phase II Rule, EPA uses the US Bureau of Census definition of Urbanized Area (UA). The mapping of Urbanized Areas is based on the most recent federal census data. This definition is uniform nationally and has a statistical basis.

For Worcester, Permit MAS010002 regulates the MS4. The permit allows all stormwater to be discharged into United States waters through all existing or new out falls operated by the Worcester DPW. The area the permit covers as stated by the permit is as follows; “This permit covers all areas within the corporate boundary of the city of Worcester served by, or otherwise contributing to discharges from new or existing separate storm sewers owned or operated by the Department of Public Works.”

WPI stormwater enters city out falls and therefore must operate under the conditions of the permit and when making a stormwater management plan WPI should do what is necessary to follow NPDES guide line and requirements. Conditions such as not discharging toxics at a toxic level, and no discharging of pollutants in quantities that would violate the water quality standards, it is important for WPI to dispose of waste properly and keep the MS4 systems clean.

## 2.4.2 Salisbury Pond

The Massachusetts Department of Environmental Protection (DEP) is responsible for monitoring the waters in Massachusetts, identifying waters that are impaired, and developing plans to bring them back into compliance with the Massachusetts Water Quality Standards. The list of impaired waters, known as the 303d list identifies river, lake, and coastal waters and the reason for impairment.

Once a body of water is identified as impaired, the DEP is required by the Federal Clean Water Act to develop a pollution budget designed to restore the quality of the impaired body of water. Developing this budget, generally referred to as a Total Maximum Daily Load (TMDL), and includes identifying the sources of the pollutant from direct discharges that are point sources and indirect discharges that are non-point sources. Also they must determine the maximum amount of the pollutant that can be discharged to a specific water body to meet water quality standards, and developing a plan to meet that goal.

Salisbury Pond is listed on the 303d list for Nuisance Aquatic Plants and Turbidity associated with high phosphorus loadings. These are indicators of a nutrient enriched system. In freshwater systems the primary nutrient known to accelerate a nutrient enriched system is phosphorus. Therefore, in order to prevent further degradation in water quality and to ensure that the pond meets state water quality standards, the TMDL establishes a phosphorus limit for the pond. Phosphorus sources include runoff from Massachusetts Highway I-190, stormwater from surrounding urban areas, and sewage contamination.

For this case, the TMDL is expressed in terms of allowable annual loadings of phosphorus because the growth of phytoplankton and macrophytes responds to changes in annual rather than daily loadings of nutrients. As the chart shows the current estimated load is 4646 kg/year, which is nearly four times higher than the 1028 kg/year target. WPI's stormwater is expressed as part of the Drain #4 storm flow. Although this is not the worst contributor into the pond it is still 26 kg/year over

the recommended loading. The bulk of the over loading into the pond comes from the Twin Culvert Inlet which contributes 4480 kg/year of total phosphorous where as the target load is 888 kg/year. Even though WPI comparably is at a good level BMPs should still be implemented to improve loading.

### TMDL Load Allocations.

Source	Current TP Loading (kg/yr)	Target TP Load Allocation (kg/yr)
Load Allocation:	0	0
Waste Load Allocation:		
Twin Culvert Inlet *	4480	888
Drain #4 Stormflow	149	123
Other drains & runoff	17	17
Total Inputs	4646	1028

\*Note that the Twin Culvert Inlet includes illicit stormwater connections, as well as runoff from MassHighways I- 190 and city streets. These sources were not separately estimated in the report.

## 2.5 Flow and Load Quantification Methods

In order to accurately estimate the load a drainage area is exposed to during a storm, a computational method will have to be selected. The most used are the rational method, the modified rational method and the NRCS method.

### 2.5.1 Rational Method

This method uses the empirical linear equation,  $Q=CiA$ , to calculate peak runoff rate for a period of uniform rain intensity. (NJ Stormwater,2004)  $Q$  is the peak discharge rate,  $C$  is a function of soil type and drainage basin slope,  $i$  is equal to rainfall intensity and  $A$  is the area of the drainage basin.(NJ Stormwater,2004) It is effective in calculating runoff for smaller areas like parking lots. In order for this method to be accurate, drainage areas should be less than 20 acres in area and have a uniform surface cover. (NJ Stormwater,2004). This method estimates runoff rates. In order for this method to calculate runoff volumes a total storm duration has to be assumed. (NJ Stormwater,2004).

### 2.5.2 Modified Rational Method

This method is an adaption of the rational method, able to produce estimates of runoff volume. This method uses the same data and equation as the rational method,  $Q=CiA$  but then uses the equation,  $V=QT_c$  to calculate the volume of the runoff,  $V$ . While  $Q$  is



again equal to peak discharge rate and  $T_c$  is equal to time of concentration. (University of Texas, 2009). Time of concentration is the longest time it could take a particle to travel from the watershed divide to the watershed outlet. The modified rational method requires the use of the most severe rainfall intensity for the area for the use of the variable  $i$ . (NJ Stormwater, 2004). This method should only be used to calculate flow for drainage areas less than 20 acres and uniform surface cover as well.

### 2.5.3 Simple Method

This method calculates the average annual pollutant load from stormwater runoff for urban areas. First the annual runoff is calculated by the equation  $R = P * P_j * R_v$ . In this equation  $R$  is equal to total runoff,  $P$  equals annual precipitation,  $P_j$  is equal to the fraction of annual rainfall of events that produce runoff (usually 0.9) and  $R_v$  is equal to the runoff coefficient. The runoff coefficient is found from the equation  $R_v = 0.05 + 0.9I_a$  with  $I_a$  equaling the fraction of the land with impervious cover. The equation  $L = 0.226 * R * C * A$  is then used to calculate the annual load,  $L$ . In the equation  $R$  is equal to total runoff,  $C$  is equal to the pollutant concentration based on land type, which will be found from the table in the index  $A$ , with  $A$  equal to area of land measurement and .226 used for unit conversion. (Stormwater Center, 2001).

## 3.0 Methodology

In order to achieve the goal of creating a Stormwater Management Plan for WPI and then designing a BMP somewhere on campus to decrease WPI's contribution to receiving bodies, information regarding stormwater runoff on campus must be acquired. This methodology section will detail the necessary steps to reach this goal, which are as follows:

1. GIS Analysis and Identification of Areas of Concern
2. Flow and Load Quantification
3. Creation of Stormwater Management Plan for WPI
4. Design of BMP

### 3.1 GIS Analysis and Identification of Areas of Concern

GIS will be an important tool to utilize throughout the duration of the project. Esri's ArcGIS will be the software used for this project. GIS will be used to analyze the campus's current drainage effectiveness, by looking at data such as the areas current drainage system (catch basins, drainage pipes, outflows), impermeable surfaces (buildings, paved areas), water bodies, land use, and topography, in order to determine what areas of campus are contributing high volumes of runoff that are dangerous to the receiving water bodies. These layers will provide an opportunity to look at the campus and surrounding area, and identify high contributing areas which we could potentially alter through the implementation of BMP's such is permeable pavement, grassy swales, green roofs, etc.. A land use layer will also provide an idea

of areas that would be appropriate for the design of a BMP on campus, providing information on allowable uses of certain parcels. (esri, 2006)

## 3.2 Flow and Load Quantification

In order to calculate the flow and pollutant load from the drainage areas determined to be highly contributing to stormwater runoff on the WPI campus the Rational Method and the Simple Method will be used. The Rational Method will be used to calculate peak rate while the Simple Method will calculate pollutant load.

Area will be calculated first using the GIS program. After comparing topography of the WPI campus with the location of storm drains, an area will be calculated. The areas will then be confirmed during an actual rain event. This will be implemented into the Simple and Rational Method for stormwater runoff equations as A for each specific section.

The next step is to determine the amount of rainfall that will occur. The Worcester, Massachusetts average annual rainfall data will be used for the precipitation variable, P. This data will be taken from the National Weather service. Rainfall intensity for the Rational method will be taken from the Mass DOT rainfall intensity table found in the index(4.2).

The final component of the Rational Method,  $c$ , runoff coefficient will be taken from the table found in index 4.3. The peak runoff volume will then be calculated.

In order to calculate total pollutant load, total annual runoff will be calculated. The stormwater runoff coefficient will be calculated first. The equation  $Rv=0.05+0.9Ia$  will be used.  $Ia$  will be found by using GIS to determine the area of impervious surfaces compared to total area of each drainage area.

After finding total runoff, the pollutant load each drainage section will be found. The equation  $L = 0.226 * R * C * A$  will be used. The concentration,  $C$ , will be from the pollutant table in the index for urban areas.(4.1)

### 3.3 Creation of Stormwater Management Plan for WPI

Creating a SMP for WPI's campus is a critical part of this project. WPI is a significant contributor of stormwater runoff in this area, and as a campus, we should aim to minimize the impact we have. Through the creation of a SMP, goals can be set to accomplish this.

The first step in the creation of a SMP for WPI will be establishing the goals of the plan. Goals typically aim decrease contribution of runoff, especially runoff potentially containing high concentrations of pollutants. Following a GIS analysis, these goals will be able to be more firmly established.

Next, an overview of existing conditions on campus will be provided. Here, the plan will describe the topography and physical characteristics of campus, along with the current drainage system on and around campus. This section will also discuss the condition of water bodies which receive stormwater runoff from WPI's campus. A GIS map of the area will be created to help portray the current conditions more clearly.

Next, the plan will discuss methods utilized to help reach the goals of the plan. A public education section will be included, which will provide information for the reader specific to stormwater concerns on WPI's campus, and how the reader can eliminate any harmful contribution they may be responsible for. A section about illicit discharge control on campus will also be provided, outlining any dumping ordinances, waste pickup/removal, etc., specific to members of the WPI community. Since WPI is a continuously growing campus, a section regarding control of construction site runoff will be provided, to ensure any construction on campus limits any potential negative effects of stormwater runoff from the construction site. Pollution prevention will also be addressed as part of the plan's methods. This will include a discussion on maintenance of grounds with regards to harmful stormwater runoff (from pesticides, etc.), and proper maintenance of campus vehicles and equipment to prevent any fluids from being introduced to the drainage system. Lastly, a section detailing common BMP's that could potentially be implemented on campus will be included.

### 3.4 Design of BMP



Based on the GIS analysis as well as flow calculations for the selected drainage areas we will determine the sections of the WPI campus that will benefit most from a Best Management Practice. This will be an area has a significant impact on WPI's runoff contribution to receiving bodies. Sections with the highest flow per drainage culvert will be selected. The specific BMP to be utilized in the project will be determined by the feasibility of the BMP to be installed in the selected area as well as the ratio of the cost per amount of stormwater reduced.

### 3.5 Tentative Schedule of Project Work to be Done

#### November 2014

Sunday	Monday	Tuesday	Wednesday	Thursday	Friday	Saturday
						1
2	3	4	5	6	7	8
	Writing SMP (related to most recent work)	→	Review and further investigation of BMP's	→	Selection of BMP to be designed	
9	10	11	12	13	14	15
	Writing SMP (related to most recent work)	→	Design of BMP	→		
16	17	18	19	20	21	22
	→					
23	24	25	26	27	28	29
	Completion of Design		Analysis of effectiveness of BMP	→	→	→
30	Notes:					

# December 2014

Sunday	Monday	Tuesday	Wednesday	Thursday	Friday	Saturday
	1	2	3	4	5	6
						
7	8	9	10	11	12	13
	Continue writing SMP				Complete SMP	
14	15	16	17	18	19	20
21	22	23	24	25	26	27
28	29	30	31			
		Notes:				



## **Works Cited**

2004, February. *Computing Stormwater Runoff Rates and Volumes* (n.d.): n. pag. Web. "Authorization Status for EPA's Stormwater Construction and Industrial Programs." *Home*. N.p., n.d. Web. 16 Oct. 2014.

*The Case for Environmental Regulatory Reform Clean Water Act NPDES Permitting* (n.d.): n. pag. Web.

Cleveland, Theodore G., David B. Thompson, Xing Fang, and William H. Asquith. *Use of the Rational and Modified Rational Methods for TxDOT Hydraulic Design*. Lubbock, TX: Center for Multidisciplinary Research in Transportation, Texas Tech U, 2011. Web. "Convocation Week at the University of Pennsylvania." *Science* 20.522 (2013): n. pag. Web.

Debo, Thomas N., Andrew J. Reese, and Thomas N. Debo. *Municipal Stormwater Management*. Boca Raton, FL: Lewis, 2003. Web.

Debo, Thomas N., Andrew J. Reese, and Thomas N. Debo. *Municipal Stormwater Management*. Boca Raton, FL: Lewis, 2003. Web.

"EPA." *National Stormwater Calculator*. N.p., n.d. Web. 16 Oct. 2014.

Minervini, William P. "Of: Sustainable Oil and Grease Removal from Synthetic Stormwater Runoff Using Bench-Scale Bioretention Studies, E. Hong; E. A. Seagren; A. P. Davis, 78, 141—155 (2006)." *Water Environment Research* 79.4 (2007): 447-48. Web. *Phase II Stormwater Management Plan, Millis, MA*. Milford, MA: Comprehensive Environmental, 2003. Web.

"Pollutants in Stormwater Runoff." *Pollutants in Stormwater Runoff*. N.p., n.d. Web. 16 Oct. 2014.

"Proposed National Rulemaking to Strengthen the Stormwater Program." *Home*. N.p., n.d. Web. 16 Oct. 2014.

"Rational Equation Calculation,  $Q=ciA$ ." *Rational Equation Calculation,  $Q=ciA$* . N.p., n.d. Web. 16 Oct. 2014.

*Soil Survey of Worcester County, Massachusetts, Northeastern Part*. Washington, D.C.?: Service, 1985. Web.

"Stormwater Homepage." *Home*. N.p., n.d. Web. 16 Oct. 2014.

"Stormwater Management Best Practices." *EPA*. Environmental Protection Agency, n.d. Web. 16 Oct. 2014.

*Total Maximum Daily Loads of Phosphorus for Salisbury Pond* (n.d.): n. pag. Web.

Us EPA, Region 1, Assistance And Pollution Prevention Office. *Best Management Practices for Colleges and Universities: Water Management: Parking Lot Storm Water Control Program, Boston University, Updated January 2007* (n.d.): n. pag. Web.

Usepa, Region 1, Office Of Site Remediation And Restoration. *Permit No. MAS010002: Authorization to Discharge under the National Pollutant Discharge Elimination System* (n.d.): n. pag. Web.

Water, Us EPA Office Of. *Urban Storm Water Preliminary Data Summary* (n.d.): n. pag. Web.

“Stormwater Management Plan Template”. Payne, Linsey, University of Oregon



## Appendix B: Surveying Results

# on Map		B.S.	HI	F.S.	Elevation
1	Q-8	0.56'	506.91'		506.35'
2	Top Tree Box (Road)			3.22'	503.69'
3	Top Tree Box Curb			2.85'	504.06'
4	Bottom Tree Box (Road)			3.51'	503.4'
5	Bottom Tree Box Curb			3.10'	503.81'
6	Top Drain (Road)			4.11'	502.80'
7	Top Drain Curb			3.76'	503.15'
8	Bottom Drain (Road)			4.13'	502.78'
9	Bottom Drain Curb			3.85'	503.06'



Figure 5: Essential Elevations Map

## Appendix C: Tree Box Filter Design Details and Additional Views

Orthographic Projection: Hidden Line with Dimensions

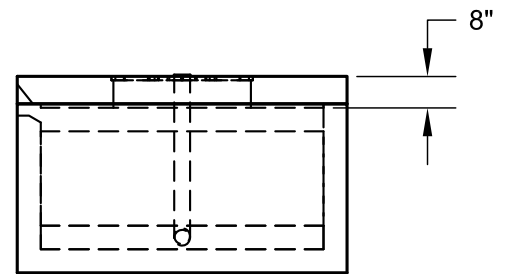
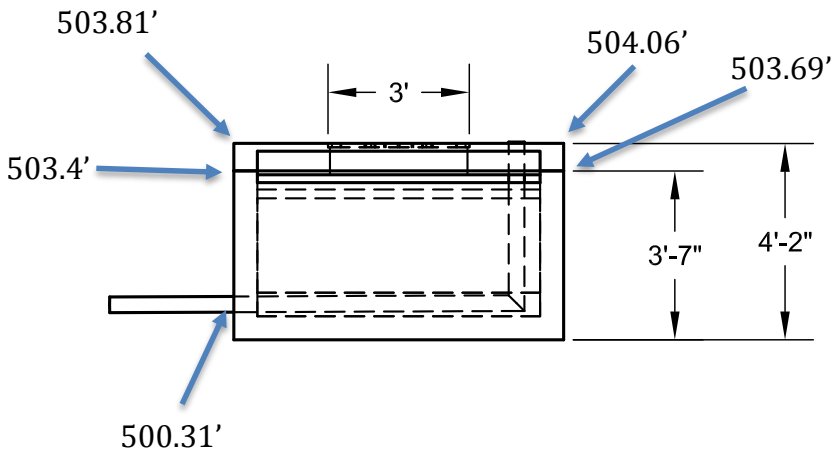
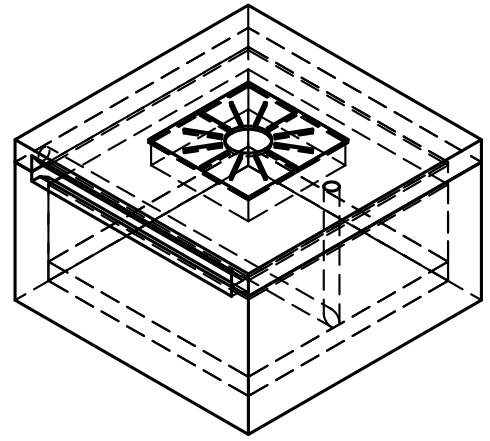
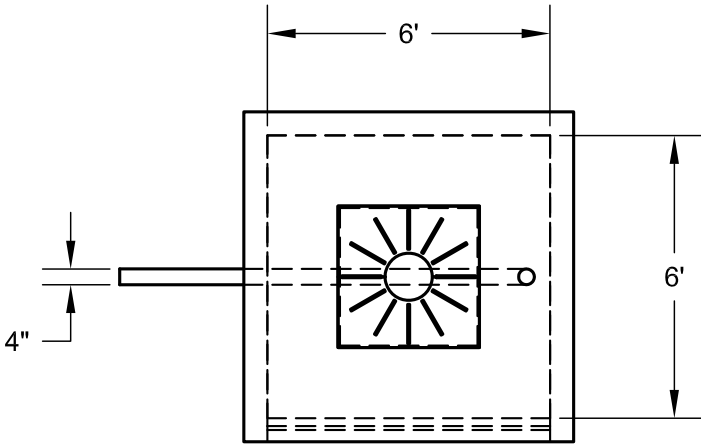

Section View: Hidden Line with Dimensions

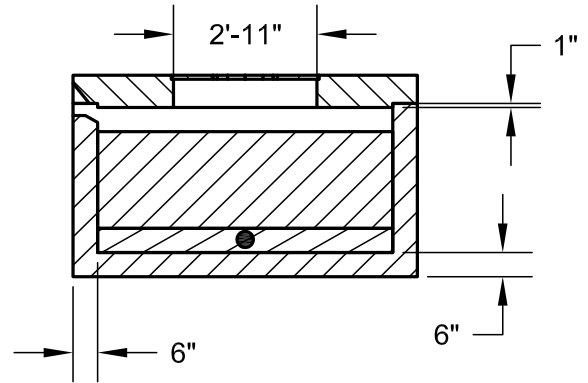
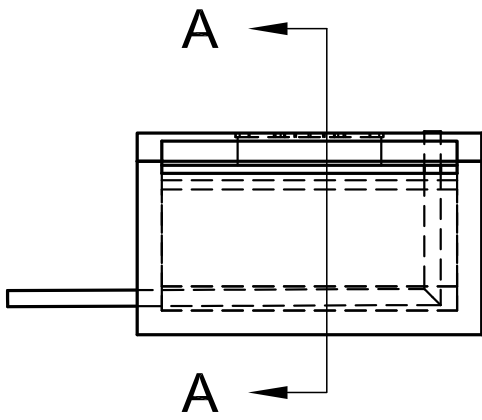

SECTION A-A  
SCALE 1:40

Realistic Rendering: Isometric View

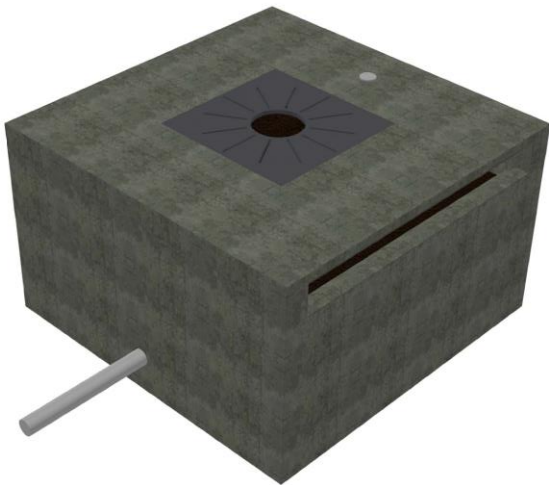

Realistic Rendering: Right Side



# A Stormwater Management Strategy for WPI



Created by:  
Brian Marsh, Ian McMullen, and Jacob Grills

Table of Contents

<b>1.0 Introduction and Goals.....</b>	<b>81</b>
<b>2.0 Existing Conditions .....</b>	<b>82</b>
<b>3.0 Public Education .....</b>	<b>84</b>
<b>4.0 Public Involvement and Participation .....</b>	<b>85</b>
<b>5.0 Illicit Discharge Control .....</b>	<b>85</b>
<b>6.0 Construction Site Runoff Control .....</b>	<b>86</b>
<b>7.0 Post Construction Runoff Control.....</b>	<b>88</b>
<b>8.0 Pollution Prevention .....</b>	<b>88</b>
<b>9.0 Best Management Practices.....</b>	<b>89</b>
<b>10.0 Conclusions and Recommendations .....</b>	<b>92</b>



## 1.0 Introduction and Goals

With a reputation for being a progressive technical institution, Worcester Polytechnic Institute (WPI) has a tremendous opportunity to serve as an example in placing an emphasis on stormwater management. A Stormwater Management Strategy for WPI will provide the college with some basic guidelines and suggestions for improving the overall quality of stormwater management on campus. This document will aim to improve stormwater management on campus, with the following goals in mind:

- Provide examples of proper stormwater management techniques.
- Decrease the concentration of pollutants in runoff entering the city of Worcester's stormwater infrastructure
- Increase the WPI community's knowledge of proper stormwater management practices.

To accomplish these goals, the document first provides an overview of the existing conditions on WPI's campus in regards to stormwater runoff. This will include a discussion of the topography of the area, along with a runoff analysis, and information regarding existing stormwater structures and receiving water bodies.

Next, some basic stormwater management strategies will be addressed. The strategies provided will address public education, public involvement and participation, illicit discharge control, construction site runoff control, post-construction site runoff control, and some basic pollution prevention strategies. These six topics are the EPA's six minimum control measures defined for operators of MS4's (EPA, 2014). The information provided is intended to provide the campus with the knowledge necessary to adequately address each of these topics, and educate the public about the impact of poor stormwater management, and how to prevent it.

Lastly, an overview of stormwater BMP's will be provided. This section is intended to describe some potential BMP's that could be implemented on campus. The BMP's

included in this section were determined to have the potential for implementation in urbanized and developed areas like WPI's campus and the surrounding area.

## 2.0 Existing Conditions

WPI's campus, located in the city of Worcester, MA, is made up of a total of approximately 80 acres atop Boynton Hill. Stormwater runoff from the campus enters the city of Worcester's municipal separate storm sewer system. The majority of this runoff is eventually discharged into Salisbury Pond in Institute Park. Using geographic information systems software, a map of campus has been created. This map displays the topography of the campus, and a basic analysis of the flow of runoff on campus. The map is displayed below in Figure 1.

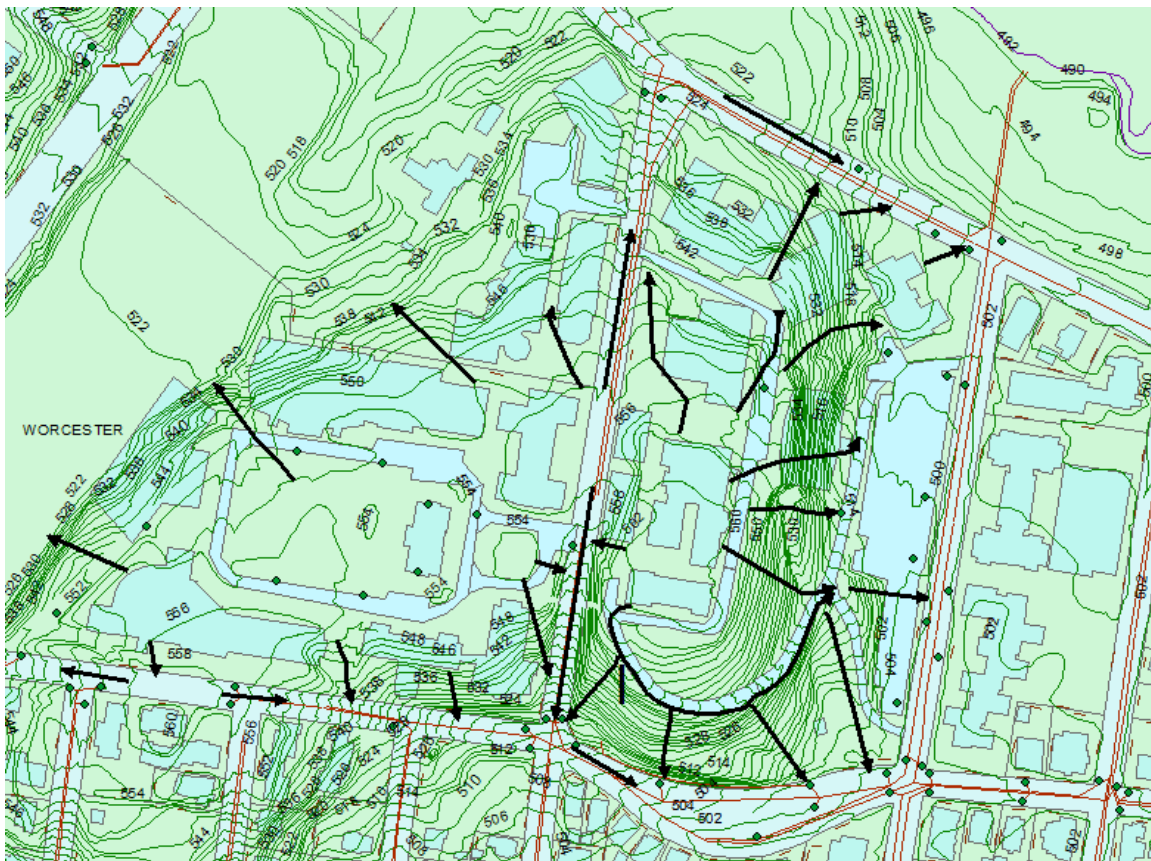

Figure 1: Flow Analysis Map

Salisbury Pond is listed on the 303d list for Nuisance Aquatic Plants and Turbidity associated with high phosphorus loadings. These are indicators of a nutrient enriched system. In freshwater systems the primary nutrient known to accelerate a nutrient enriched system is phosphorus. Therefore, in order to prevent further degradation in water quality and to ensure that the pond meets state water quality standards, the TMDL establishes a phosphorus limit for the pond. Phosphorus sources include runoff from Massachusetts Highway I-190, stormwater from surrounding urban areas, and sewage contamination.

For this case, the TMDL is expressed in terms of allowable annual loadings of phosphorus because the growth of phytoplankton and macrophytes responds to changes in annual rather than daily loadings of nutrients. As Table 1 shows, the current estimated load is 4646 kg/year, which is nearly four times higher than the 1028 kg/year target. WPI's stormwater is expressed as part of the Drain #4 storm flow. Although this is not the worst contributor into the pond, it is still 26 kg/year over the recommended loading. The bulk of the over loading into the pond comes from the Twin Culvert Inlet which contributes 4480 kg/year of total phosphorous whereas the target load is 888 kg/year. Even though WPI comparably is at a good level, BMPs should still be implemented to decrease pollutant loads.

Table 1: TMDL Load Allocations

Source	Current TP Loading (kg/yr.)	Target TP Load Allocation (kg/yr.)
Load Allocation	0	0
Waste Load Allocation		
Twin Culvert Inlet	4480	888
Drain #4 Stormflow	149	123
Other drains and runoff	17	17
Total Inputs	4646	1028

\*The Twin Culvert Inlet includes illicit stormwater connections, as well as runoff from MassHighways I- 190 and city streets. These sources were not separately estimated in the report.

(Salisbury Pond, 2002)

### 3.0 Public Education

Stormwater is water collected on the ground from either rain or snow. In an ideal environment stormwater would slowly infiltrate into the soil and naturally filter away pollutants before entering a water body. With the current development in our cities, impervious surfaces such as roads, sidewalks and buildings speed up the water's path to a waterbody. Since the stormwater is not allowed to penetrate the surface, it enters the waterbody unfiltered with any pollutants it collects.

Comparing runoff between pervious and impervious surfaces

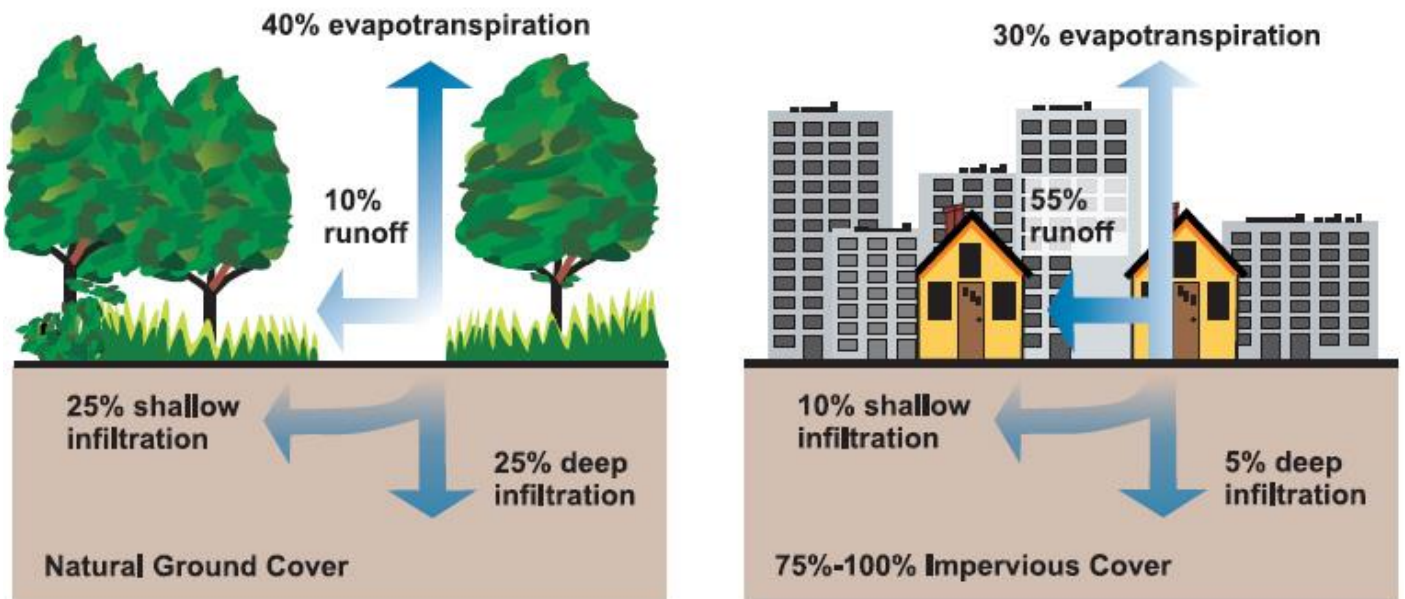

(Green Technology, 2013)

When the unfiltered stormwater enters the waterbody many pollutants such as sediments, excess nutrients, household hazardous waste, debris and pathogens enter the ecosystem. Sediments cloud the water, making it difficult for aquatic plants to grow as well as destroy aquatic habitats. (Lake Superior Streams, 2011). Excess nutrients, such as phosphorus and nitrogen, can cause algae blooms which decrease oxygen levels causing aquatic life to suffer. Household wastes like pesticides,

insecticides and motor oil can poison aquatic life when entered into the water system. (EPA, 2014). Without any infiltration into the ground these pollutants enter and disrupt the natural balance.

#### 4.0 Public Involvement and Participation

In order to effectively improve the quality of stormwater management, cooperation amongst the public is required. To achieve this, public participation must be encouraged. In order to improve public participation, citizens should be properly educated on the importance of proper stormwater management.

By hosting workshops on stormwater management, WPI can tremendously increase public knowledge of good stormwater management techniques. As a leading technical institution, WPI has at its disposal a wealth of knowledge on the topic of stormwater management between both its students and professors. The civil and environmental engineering department can bear the responsibility of this public education. A Stormwater Management Improvement group should be created within the department, with the primary task of increasing public awareness.

Common behaviors such as littering, washing cars, and changing motor oil have the potential to pollute receiving water bodies. A Stormwater Management Improvement group should properly educate the public on proper disposal methods of such contaminants. As well as addressing these common behaviors, this group would have a unique opportunity to educate prospective engineers on the potential for the implementation of progressive stormwater BMP's in their future projects.

#### 5.0 Illicit Discharge Control

Illicit discharge is considered to be any discharge to a stormwater sewer system that is not composed of only stormwater. Most of these discharges are cases of illegal dumping into catch basins and even directly into water bodies. Typically, this illegal dumping is occurring to avoid paying fees to properly dispose of hazardous materials

or trash. Illegal dumping in Massachusetts, outlined in General Laws Part IV, Title I, Chapter 270, Section 16, is punishable by a fine of up to \$5,500 for the first offense, and up to \$15,000 for each subsequent offense.

The most important method of combatting this illegal dumping is public education. Posted signage near local water bodies is an effective technique in increasing awareness of illegal dumping, and informing citizens of the potential legal consequences of illegal dumping. With much of WPI's stormwater runoff eventually entering Salisbury Pond, posting "no dumping" signs sporadically through the campus's surrounding neighborhoods and in Institute Park would be a good start toward decreasing illicit discharges.

An alternative method of controlling illicit discharges would be to promote reporting of illegal dumping witnessed by citizens. To do this, a hotline could be created where such events could be reported. The creation of this hotline would result in a dramatic increase in the ability of illegal dumping to be reported, as the hotline could be promoted on "no dumping" signs placed throughout the area.

#### 6.0 Construction Site Runoff Control

As a growing university, there is frequently construction on WPI's campus. Construction sites have the potential to significantly impact the water quality of stormwater runoff, with possible erosion due to construction leading to an increase of sediment and other pollutants entering stormwater infrastructure, and ultimately receiving water bodies. This increase in sediment can lead to increased turbidity in receiving water bodies, leading to adverse effects on aquatic plants and fish.

The National Pollutant Discharge Elimination System (NPDES) permit program regulates point sources discharging pollutants in receiving water bodies. This program requires those operating construction sites disturbing one or more acres of land to obtain coverage under a NPDES permit for their discharges. The construction

site operators are required to abide by the EPA Construction General Permit. To obtain this permit, a site operator must first submit a Notice of Intent to be covered under the general permit. After this is submitted, the EPA reviews construction plans to determine whether or not the site will be covered under a general permit.

The EPA Construction General Permit requires the site operator to abide by the Construction and Development rule, which includes non-numeric effluent limitations and a numeric effluent limit for turbidity (applicable to construction sites disturbing 10 or more acres), regulating the discharge of pollutants from construction sites.

The non-numeric limitations are intended to limit the discharge of sediment and other pollutants from construction sites. These limitations force the permittee to utilize methods of controlling erosion on the site. These methods should control runoff volume and velocity, minimize the amount of soil exposed during construction, minimize the disturbance of steep slopes, provide and maintain natural buffers around surface waters, and minimize soil compaction.

Non-numeric limitations also provide an overview for pollutant prevention measures and prohibited discharges. Pollution prevention measures include minimizing the discharge of pollutants caused by the washing of construction equipment, minimizing the exposure of building materials to precipitation, and minimizing the discharge of pollutants from spills and leaks of hazardous materials on the construction site. Prohibited discharges include wastewater from washout of concrete and other construction materials, and fuels and oils used in construction vehicles.

The numeric limitations provide a limit for turbidity of discharged water. This limitation states that the average turbidity of any discharge must not exceed 280 nephelometric turbidity units. The Construction and Development rule requires discharges to be monitored and analyzed for turbidity through sampling in accordance with the issued permit. This limitation, however, only applies to construction sites disturbing 10 or more acres of land at a time.

### 7.0 Post Construction Runoff Control

Even after construction is complete, these sites still present potentially high levels of sediment and pollutants that can be gathered in runoff. In accordance with NPDES requirements, MS4 operators are required to address post construction runoff from new development. Operators are responsible for developing strategies which incorporate stormwater BMP's. This can largely be achieved by seeking to minimize impervious areas and/or incorporating structural BMP's in site designs.

With a track record of utilizing progressive stormwater techniques in site designs, such as the Green Roof on East Hall, WPI should seek to continue this trend. Including stormwater BMP's in construction designs can help to not only improve the quality of stormwater management on campus (including post construction runoff), but can also assist in the attainment of Leadership in Energy and Environmental Design (LEED) certifications and in turn, the potential for government funding for green design. Incorporating these practices in future construction can help WPI both decrease its contribution of pollutants to Salisbury Pond, and further enhance the university's reputation as an environmentally conscious institution.

### 8.0 Pollution Prevention

Campus facilities also have the potential to contribute pollutants to stormwater runoff. Activities such as landscape maintenance and vehicle maintenance can contribute pollutants such as oil, grease, and nutrients that will ultimately be carried in stormwater runoff to Salisbury Pond. To combat this potential for increased pollutants, stormwater training should be incorporated in general safety training procedures, detailing proper waste disposal especially.

One method of pollution prevention already being utilized on campus is the use of organic, natural based materials for pest prevention. Taking advantage of the use of



these materials prevents harmful chemicals contained in pesticides from being carried in stormwater runoff and further polluting Salisbury Pond.

#### 9.0 Best Management Practices

Best management practices (BMP's) are techniques and structures that help to either reduce the quantity of stormwater entering stormwater drainage systems or reduce the concentration of pollutants in stormwater runoff. Depending on the geography of the area, certain BMP's may be more or less feasible for use. In the case of WPI's campus, BMP's which are favorable for use in highly developed or urban areas should be considered. These BMP's are feasible for use in areas that may have limited open space and heavy foot traffic. The remainder of this section will detail a few examples of BMP's fitting this criteria.

#### **Permeable Pavements**

Permeable pavement is used as an alternative to asphalt or concrete surfaces and it allows stormwater to drain through the porous surface to a stone reservoir underneath. Permeable Pavements acts as filters, purifying the water from pollutants, before allowing infiltration and restoring groundwater. The appearance of the surface is often similar to asphalt or concrete, but it is manufactured without fine materials such as sand, but instead uses a paste for a thick coating over aggregate materials to create open voids in the pavement. Although this lowers the structural integrity of the pavement, it does not show in application. (Pervious Pavement, 2014)

By filtering the water through different aggregate sizes and usually a filter fabric, permeable pavements are able to remove total suspended solids, phosphorus and nitrogen pollutants. Pervious pavement allows for up to 80% infiltration of stormwater at a usual rate of 3-5 gallons per minute per square foot. Maintenance includes sweeping the area of sand and debris so the particles do not collect in the voids of the pavement. (University of Maryland, 2012)

The University of Rhode Island has installed two porous asphalt parking lots totaling 6.97 acres. The lots were made with 2.5 inch thick porous asphalt and a 2% slope to allow for maximum percolation. Underneath is a one inch thick fabric filter and 3 feet of crushed stone leading to the natural soil. The project totaled \$3,033,700 with demolition costs. This porous pavement resulted in a 95% elimination of suspended solids and a 70% elimination of phosphorus pollutants. Durability issues were seen when it received frequent use as well as when stationary cars turned their tires, but it did not affect percolation rates. (RIDOH, 2013)

### **Tree Box Filters**

Tree filter boxes are a type of bio-retention BMP that is often utilized in urbanized and developed areas. The basic idea behind a tree box filter is to have runoff directed along impervious surfaces toward the retention box. The retention box is accessed by the runoff through a curb inlet. Once the runoff enters the retention box it passes through an engineered soil mix, which helps filter solids and contaminants out of the runoff. After passing through the engineered soil, the runoff that makes it through enters a layer of crushed stone. It passes through the crushed stone, which provides additional removal, and makes its way towards an outlet pipe, which will then divert the treated stormwater back into the municipal stormwater system.

Tree box filters are used often in urbanized and developed areas because of its pleasing aesthetics and how easy it is to use in retrofitting projects. Tree box filters are able to add vegetation to areas that often lack it. They are very easy to fit into developed areas as well, as they are very compact and tie into existing stormwater systems.

In October, 2006, the Grande Dunes Marina in Myrtle Beach, SC put in 25 Filterra bio-filtration systems (a tree box filter style bio-filtration system). The Grande Dunes Marina is home to many different species of wildlife and plants, and therefore must

meet specific state and federal stormwater discharge requirements (Grande Dunes, 2006). The builder's decided on installing the Filterra systems due to their high pollutant removal rates. Filterra bio-retention systems have been shown to remove pollutants at the following rates, displayed in Table 2:

Table 2: Filterra Removal Rates

TSS Removal	85%
Phosphorous Removal	60%-70%
Nitrogen Removal	43%
Total Copper Removal	>58%
Dissolved Copper Removal	46%
Total Zinc Removal	>66%
Dissolved Zinc Removal	58%
Oil and Grease	>93%

(Filterra, 2014)

### **Rain Barrels and Cisterns**

Rain barrels and cisterns are used for harvesting rainwater for reuse. The major difference between them is their size rain barrels are significantly smaller than cisterns. Rain barrels have much more of a residential application and can be placed outside under a down spout to collect rainwater. Rain barrels of this type are usually around 50 gallons. Cisterns are more for commercial use and they can be above ground but most are put underground and have no limit on size with some holding over 100,000 gallons. For an application like a school a cistern would be the best option. It would be a low cost way to reduce runoff volume and can, for smaller storms reduce the peak runoff rates. The water that is collect is a chemically untreated "soft water" and its best uses are irrigation to gardens and lawns and water can also be used for flushing toilets. Depending on the type of system installed some don't require pumps and can use gravity to transport water where it needs to be.

Worcester having harsh winter conditions and elongated times of freezing temperatures the best options would be an underground cistern to avoid having to shut down the system in the winter. Heaters could be used but it is a cost defeating options because the length of time the heaters would run would cut into the cost

savings of the system. A properly installed system depending on materials and proper installation can last for 75 years or more with savings per year depending on the amount of water collected and used.

The cost to install an underground cistern depends on the material used. In the tables below you can see the cost per gallon of different tank types and the cost of installation is on average about 59% of the tank cost. Meaning if a 15,000 gallon steel tank was purchased it would cost \$37,650 and the cost of installation would be \$22,213.50 making the total cost \$59,863.50. This model is with the most expensive option and is nearly double what a normal cost would be. It also needs to be noted that costs will vary based on company of choice and current economic values.

#### 10.0 Conclusions and Recommendations

This document covers the six minimum control measures as defined by the EPA for a stormwater management program for operators of MS4's. Using this stormwater management strategy as a basis, a more detailed stormwater management plan can be created for WPI. Aside from these six minimum control measures, a plan for continuous improvement should be included in the plan. In the absence of this plan, however, this stormwater management strategy should be utilized to help WPI formally address the six minimum control measures.