

A Novel Approach to Reducing Plastic Waste in the Ocean

W.H.A.L.E.S. : Wayde Whichard, Hailey Fink, Anish Nakahara, Liam Costello, Emma Williams, Samantha Logan
 Advisors: Svetlana Nikitina, Diran Apelian

Abstract: It is a well-known fact that there is an alarmingly large amount of waste, specifically plastic waste, polluting our oceans and bodies of water. These plastics are deteriorating into micro plastics that are being consumed by the lowest levels of the food chain and are already on our plates, which in turn is impacting our health.

Technology

Collector of Recyclable and Identifiable Local Litter

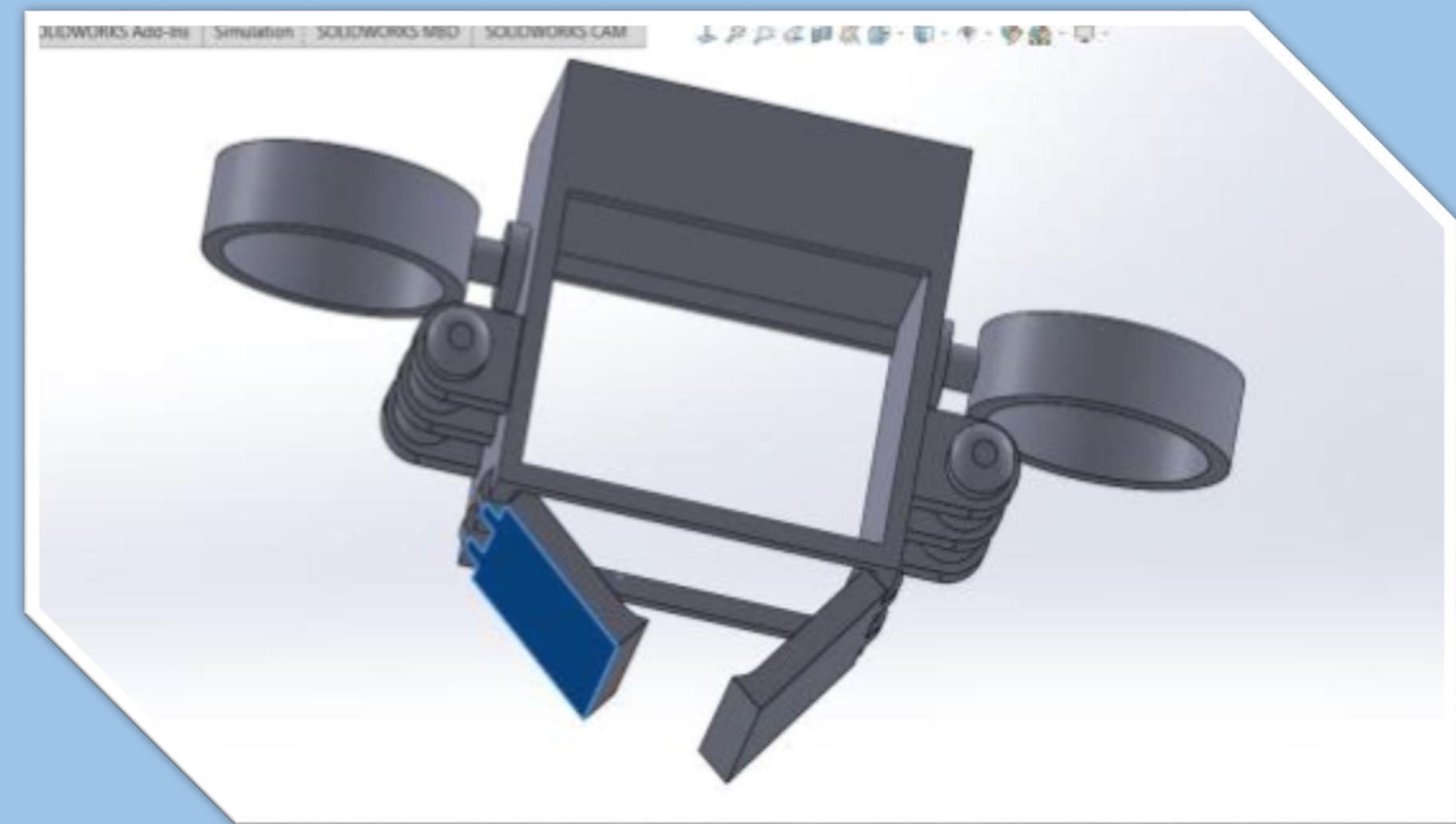

The C.R.I.L.L. technology offers a way of getting ocean plastic out of deeper waters and delivering it for recycling to the parent company. C.R.I.L.L. is a submarine with a storage space and a retrieval mechanism in the shape of two swinging flaps, and propulsion systems in the form of ballast tanks and propellers.

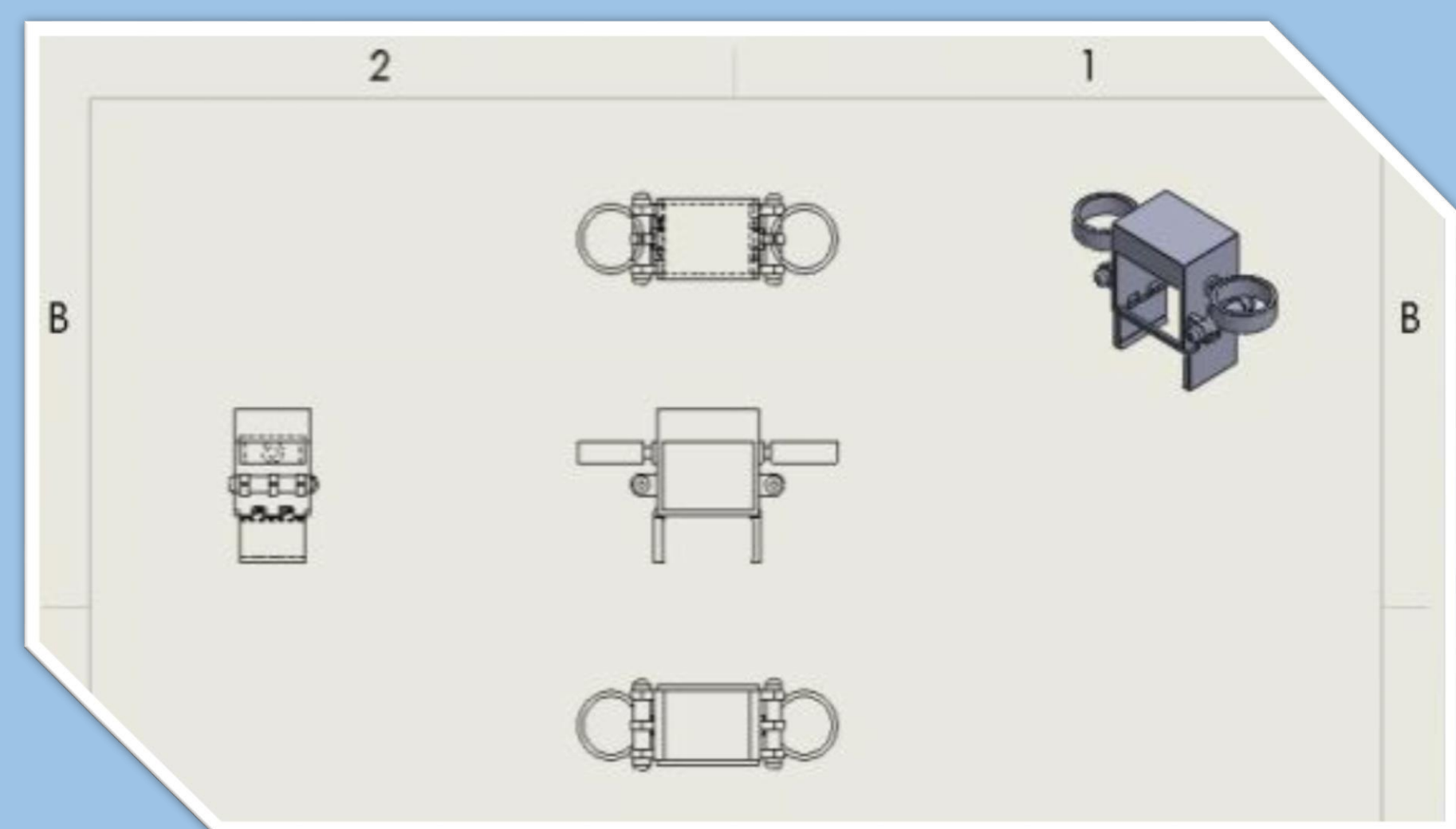

C.R.I.L.L. is controlled via VSF signal. The submarine would have a battery life between 2-3 hours and allow operation in the twilight zone, between 200 to 1000 meters. This is where most ocean trash can be found.

Business Model

W.H.A.L.E.S. is conceived as a company whose business model includes the retrieval from the ocean around Cape Cod of smaller macro plastic products (wrappers, bottle caps, etc.) using our patented C.R.I.L.L. Technology. The company will also produce and market branded beach toys made from collected recycled plastics with the goal of raising awareness among children about the pollution in the ocean by offering a colorful book with an instructional narrative to accompany the purchase of each toy.



By using plastic harvested from the ocean, not only are we preventing the production of new plastic, but we are also preventing said plastic from further damaging the environment



Plastics From the Ocean[Photograph found in N/a, Nature.com].(n.d.). Retrieved from <https://goo.gl/images/AJNmCp>

Education

Wesley the Whale is a story about a young whale that was out swimming in the ocean and is suddenly hurt. He's hurt by the pollution in his region of the ocean. After he finds out the humans are the ones throwing trash in the water he decides to go to shore and fix it.

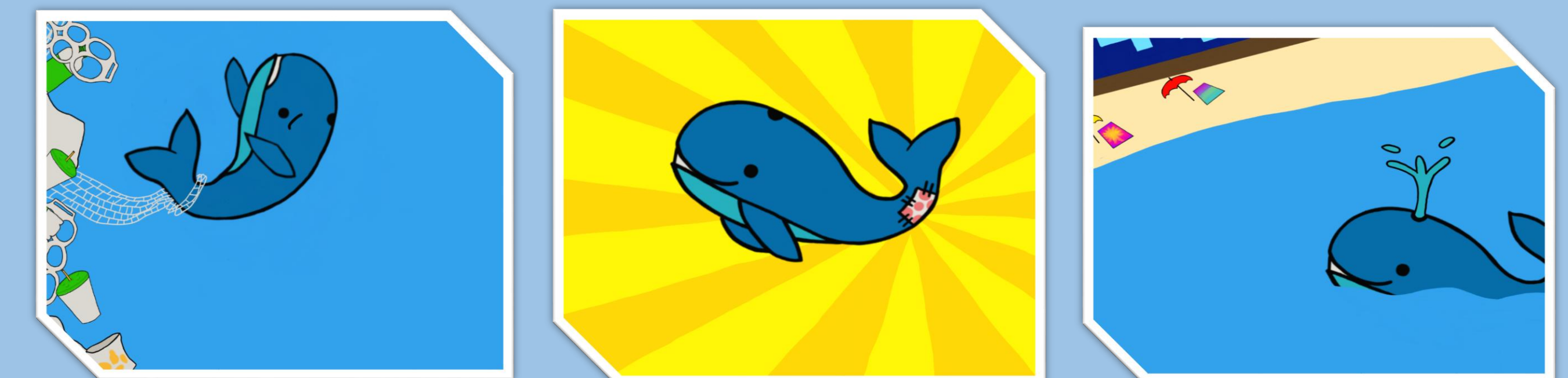

Wesley the Whale is the educational story we created to teach younger children about the negative aspects of water pollution in the world today. The story's goal is to encourage children to be more involved in the environment by showing them the harm human neglect can cause. After being exposed to this, the goal is to have them feel encouraged to go out and help Wesley's quest to clean the ocean.



To go with our narrative we created beach toys that are branded to match our book. The company W.H.A.L.E.S. would most likely do a promotion when selling our toys, where customers would get the book along with the purchase of the toys. When playing with the toys, we hope the children will remember the story and feel encouraged to share it with their playmates, and in turn educating more youth.