

# Rotating Cylinder Valve Engine

A Major Qualifying Project (MQP)  
submitted to the faculty of Worcester Polytechnic Institute  
in partial fulfillment of the requirements for the  
degree of Bachelor of Science

By:

Jack Parker  
Devin Patel  
James Ralph  
Jiwon Shon  
Molly Vincent  
Michael Zembruski

Submitted:

Approved By:

Professor Selçuk Güçeri, Advisor  
Mechanical Engineering Department  
guceri@wpi.edu



# WPI

*This report represents the work of one or more WPI undergraduate students submitted to the faculty as evidence of completion of a degree requirement. WPI routinely publishes these reports on the web without editorial or peer review.*

# Table of Contents

<b>Table of Contents</b> .....	<b>2</b>
<b>List of Tables</b> .....	<b>3</b>
<b>List of Figures</b> .....	<b>3</b>
<b>Acknowledgments</b> .....	<b>4</b>
<b>Abstract</b> .....	<b>5</b>
<b>1.0 Introduction</b> .....	<b>6</b>
<b>2.0 Background</b> .....	<b>7</b>
2.1 RCV Engines and their Applications.....	7
2.2 History of RCV Engines.....	8
2.3 Design Components of RCV Engine.....	10
2.4 Benefits of RCV Engine Design.....	11
2.5 Drawbacks of RCV Engine Design.....	12
<b>3.0 Methods</b> .....	<b>13</b>
3.1 Reverse Engineering.....	13
3.2 Component Selection.....	13
3.2.1 Gear Selection.....	14
3.2.2 Gear Material.....	14
3.3 Measuring.....	15
3.4 CAD.....	18
3.5 Design Analysis.....	23
3.6 Computer Aided Machining.....	24
3.6.1 CAM Milling Operations.....	25
3.6.2 CAM Turning Operations.....	27
3.7 Machining.....	28
3.7.1 Factor of Safety and Material Choices.....	28
3.8 Engine 4-Stroke Cycle Timing.....	29
<b>4.0 Results</b> .....	<b>32</b>
<b>5.0 Analysis and Discussion</b> .....	<b>33</b>
<b>6.0 Recommendations</b> .....	<b>34</b>
6.1 Manufacturing.....	34
6.2 Testing.....	34
<b>References</b> .....	<b>35</b>
<b>Appendix A: Engine Safety and Running the Engine</b> .....	<b>37</b>
<b>Appendix B: Individual Engine Solidworks Part Views</b> .....	<b>39</b>

## List of Tables

Table 3.1: Piston rod measurements (mm).....	16
Table 3.2: Piston head measurements (mm).....	16
Table 3.3: Crankshaft measurements (mm).....	17

## List of Figures

Figure 1: Single prop model airplane (Pimentel, 2021).....	7
Figure 2: Unmanned surveillance drone (Sparkes, 2021).....	8
Figure 3: Knight Engine (Hendry, 1972).....	9
Figure 4: Cross Rotary Engine (Gerould, 2023).....	10
Figure 5: RCV Engine Cross Section View (Yarrish, n.d).....	11
Figure 6: Rotating cylinder valve spring seal system (Lawes, 2002).....	12
Figure 7: RCV-90 engine, disassembled.....	13
Figure 8: Cylinder gear (left) and crank gear (right).....	14
Figure 9: Piston rod (top left), piston head (top right), and crankshaft (bottom).....	17
Figure 10: RCV-90 inner crankcase CAD.....	18
Figure 11: YS-160 DZ engine internals CAD.....	19
Figure 12: Inner cylinder and gear attachment detail view.....	20
Figure 13: Inner crankcase assembly.....	21
Figure 14: Outer crankcase component.....	21
Figure 15: Inner cylinder (left) and outer cylinder Shell (right).....	22
Figure 16: Full engine assembly (left) and full engine cross-section view (right).....	23
Figure 17: Cylinder shell thermal study results.....	24
Figure 18: Adaptive clearing operation tool path generated in Fusion 360 for the large gear .....	25
Figure 19: Custom feeds and speeds for milling operation on the steel bevel gear.....	26
Figure 20: Comparing using multiple depth (left) and not using multiple depth (right).....	26
Figure 21: Turning operation generated in Fusion 360 for the crankshaft.....	27
Figure 22: Cylinder shell port angles.....	30
Figure 22: Mechined Outer Cylinder Shell.....	32

## **Acknowledgments**

We would like to thank a few people who showed us tremendous support throughout our project. First off we would like to thank our advisor Selçuk Güçeri for all his guidance and the time he dedicated to supporting us and our project. Throughout our project, Professor Güçeri helped us by providing us with his extensive knowledge of engines and provided us with lots of feedback for a much smoother process.

We would also express our gratitude for the TA staff in Washburn Shops for making our project possible. Our great thanks especially to Nikolaos Gerakaris, Arjun Ramakrishnan, and Kelli Huang for their help.

We would also like to thank Barbara Fuhman from the Mechanical Engineering department, for assisting us in our team's finances and helping our group order all the parts we needed for our project.

Lastly, we would like to thank all the professors at WPI who have helped us along the way, Professor Christiansen.

## **Abstract**

This project aims to design, prototype, manufacture, and analyze a rotating cylinder valve (RCV) engine. The RCV engine is an internal combustion engine which forgoes a traditional valvetrain and camshafts, instead using a rotating valve attached to the cylinder. This design offers advantages in efficiency, power output, and emissions control. The project includes three main phases, conceptual design and simulation, prototype development, and performance evaluation. The history of this engine and its operating principles are introduced, followed by an analysis of its operation. A new, larger 1.6 cubic inch RCV engine is then designed and manufactured, and plans are made for testing and evaluation.

## **1.0 Introduction**

This project revolves around the development and manufacturing of a rotating cylinder valve (RCV) engine. Originally designed by Charles Yale Knight, whose work introduced the concept of rotating cylinders in engine designs, the Knight Engine set the stage for future generations of engines. They work by utilizing a rotating cylinder with a porthole that aligns with openings in the engine block. As the cylinder rotates, the porthole aligns with the intake, spark plug, and exhaust openings in the outer shell, allowing air and fuel to enter, compressing the mixture, igniting it, and expelling exhaust gasses. Unlike conventional engines, RCV engines bring the simplicity and affordability of a 2-stroke engine but with the mechanical advantages of a 4-stroke engine. Tasked with creating a new RCV engine from scratch, our team was given an example RCV-90 and RCV-120 engine by Professor Güçeri, the team's project advisor, to model our new engine off of, with the goal of upscaling it to a RCV-160 size.

The overall goal for the project was to design, manufacture, and assemble a fully operational RCV engine. We were also tasked to build upon and improve the design from the previous RCV engines provided. With this in mind, we disassembled and reverse-engineered the original RCV-90 engine to understand the inner workings of the engine, the materials on the individual parts, and the assembly of the mechanisms. Professor Güçeri also guided us throughout the project, reviewing our decisions for certain components, and suggesting ideas on how to approach issues or questions the team ran into. He also approved purchasing gears, bearings, and other parts from online manufacturers, allowing the team to focus on the design aspect of the engine.

## 2.0 Background

### 2.1 RCV Engines and their Applications

An RCV engine is an engine that is built around a combustion chamber that contains a rotating valve capable of controlling the gas exchange process. RCV engines utilize the simplicity and cost of a 2-stroke engine by eliminating the need for a camshaft, while maintaining the mechanical benefits of a 4-stroke engine. The internal cylinder rotates at half the rotational speed of the axial piston. A single hole in the cylinder allows air intake, air exhaust, fuel intake, and ignition all in two full rotations of the piston. The RCV-90, referring to the 0.90 cubic inch (~15cc) engine displacement, presents notable advantages over conventional camshaft-valve engines. Its simplified design boasts fewer moving parts, resulting in enhanced reliability and reduced maintenance requirements. The compact cone shape of the engine enables an efficient utilization of space, which is especially important for aerospace applications where weight, payload capacity, and nose aerodynamics are crucial considerations. While historically employed in model and RC airplanes, the versatility of the RCV engine extends far beyond this niche application. Figures 1 and 2 show two practical usages of this type of engine.



Figure 1: Single prop model airplane (Pimentel, 2021).



Figure 2: Unmanned surveillance drone (Sparkes, 2021).

Due to the simplistic and condensed design, RCV engines can be used for many unmanned aerial vehicles (UAVs). Militaries utilize RCV engines for their drones and other UAVs due to the benefits such as offering superior fuel economy, quiet running, and excellent starting reliability. A notable example is RCV Engines Limited, a British company actively exploring the incorporation of RCV engines into unmanned drones for a multitude of applications, showcasing the engine's adaptability and potential for innovation in emerging technologies.

## 2.2 History of RCV Engines

Charles Yale Knight revolutionized the engine industry with his original design of the Knight Engine, introduced in 1905. This engine, shown below in Figure 3, featured a rotating cylinder that replaced the conventional poppet valves of an engine to control intake and exhaust by aligning ports to regulate the flow of air and fuel (*Jaguar Daimler Heritage Trust*, n.d.). Knight's goal for this design was to reduce noise and vibrations from the engine's valves while improving fuel and power delivery.



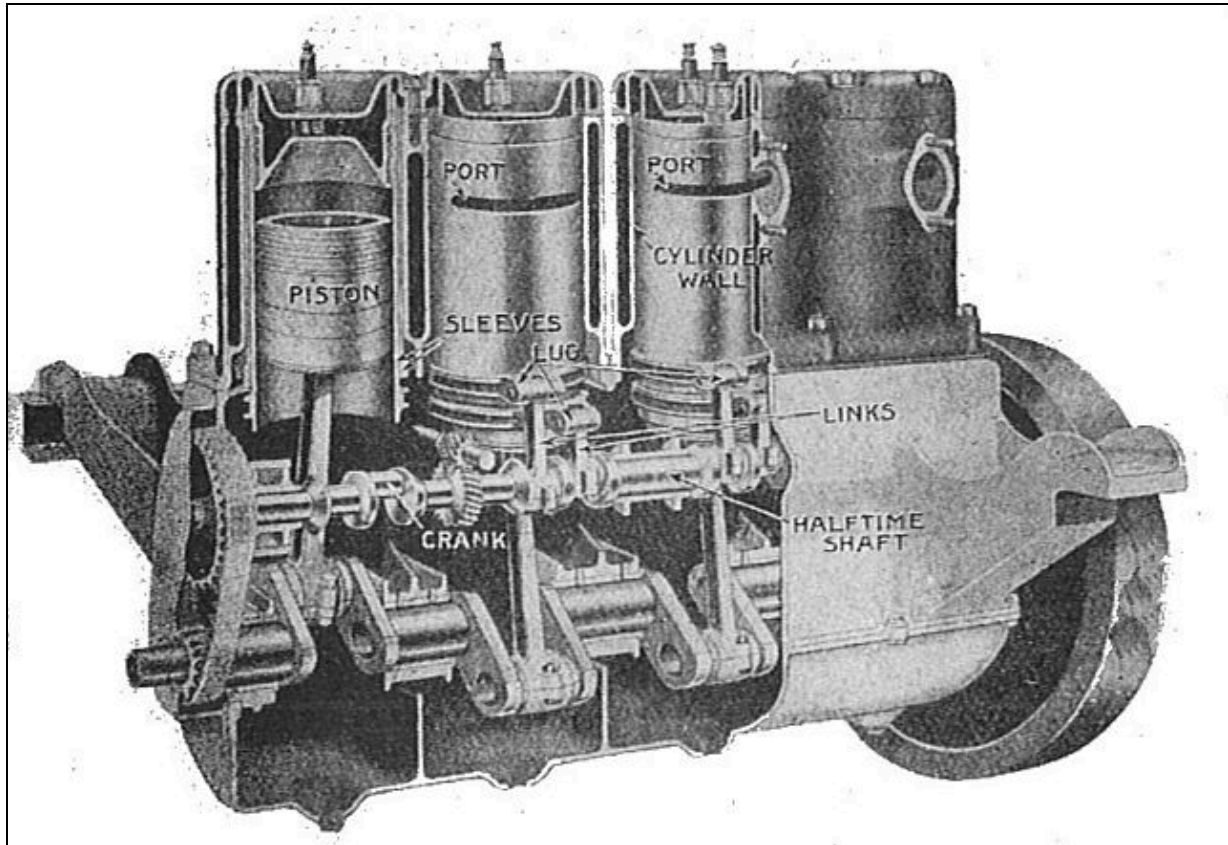

Figure 3: Knight Engine (Hendry, 1972).

Knight's contributions extended beyond his own engine to advancements in poppet valve designs and the later development of Roland C. Cross's Rotary Engine, shown in Figure 4. The Cross Rotary Engine was originally designed to be a motorcycle engine fitted with a Cross rotating cylinder valve, running a compression ratio of 10.5:1, showcasing the versatility and potential of alternative engine configurations (*R.C. Cross Motorcycles*, n.d.).

The modern RCV Engine is a rotary valve four-stroke engine modeled off of these previous engines. RCV Engines have long been known for its advantages over traditional poppet valve designs, offering improved performance and efficiency.

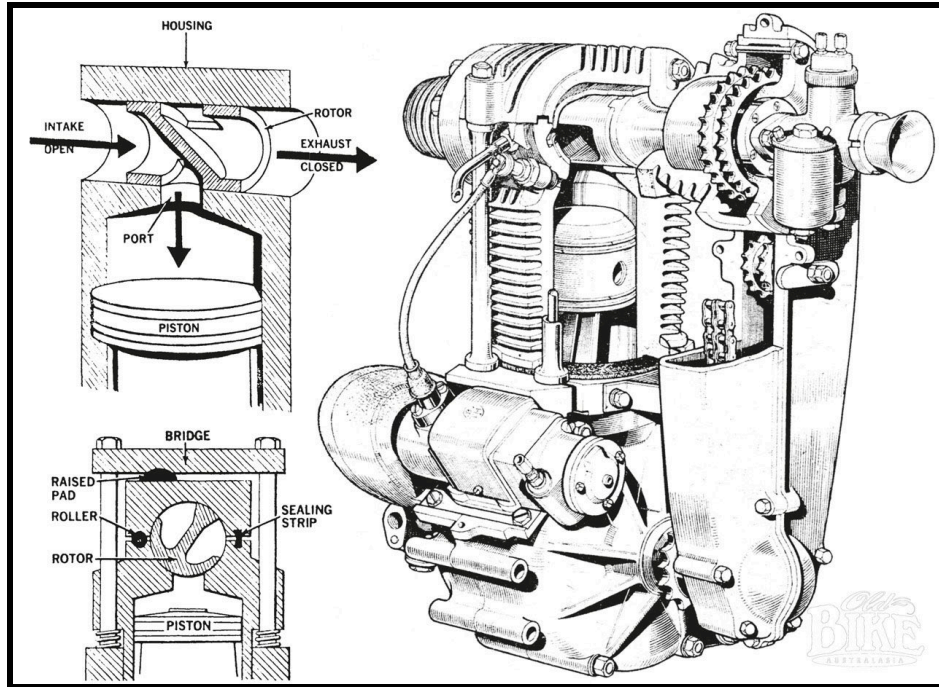

Figure 4: Cross Rotary Engine (Gerould, 2023).

### 2.3 Design Components of RCV Engine

The centerpiece of the RCV engine is the piston cylinder. This cylinder works as the axle, piston cylinder, and bevel gear, streamlining multiple processes into one piece. A small bevel gear on the crankshaft meshes perpendicularly with the larger bevel gear on the cylinder at a 2:1 tooth ratio. This ratio ensures that the cylinder spins once for every two rotations of the crankshaft, making this engine function in four-stroke style. Positioned at the top end of the cylinder is a single port leading to the combustion chamber, while a fixed timing ring features three radial ports for inlet, ignition, and exhaust functions. The combustion chamber goes through intake, compression, power, and exhaust, just like the operation of a standard four-stroke engine. The piston, with the use of a piston ring, forms the primary combustion seal, creating a highly reliable method capable of maintaining gas sealing and lubrication, even under the demanding conditions of high sliding speeds and harsh thermal environments. To withstand and transmit combustion and reciprocation forces, a conventional conrod and crank mechanism are utilized, ensuring robust performance and durability.

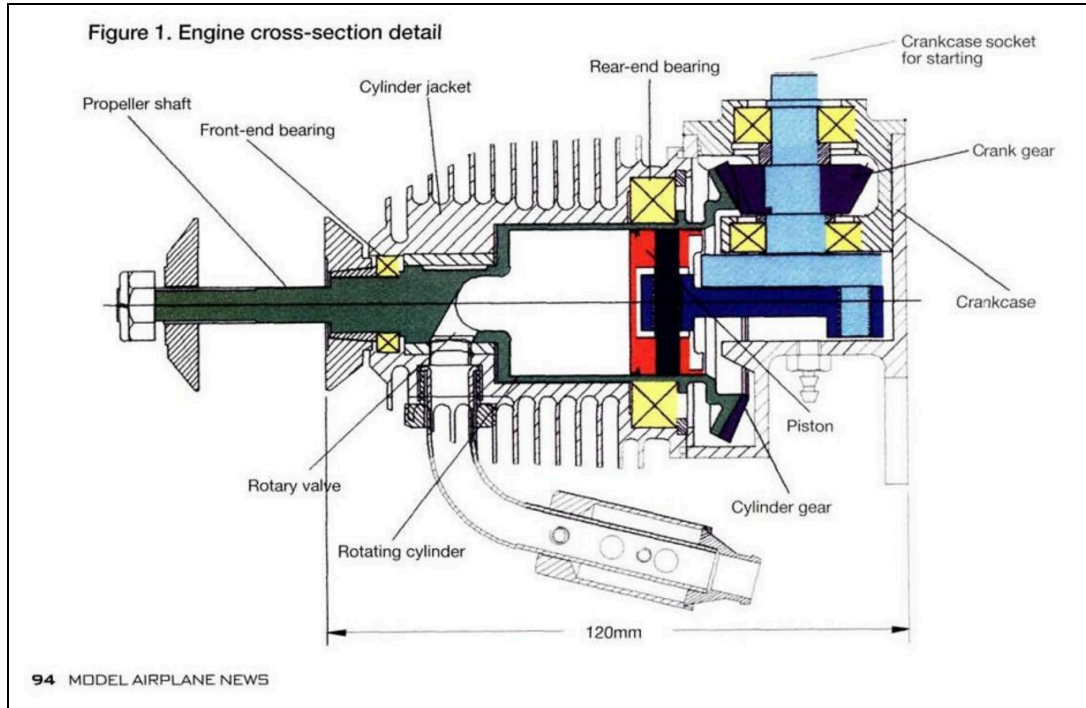

Figure 5: RCV Engine Cross Section View (Yarrish, n.d).

## 2.4 Benefits of RCV Engine Design

The RCV Engine has many advantages over conventional engine designs. The first is the manufacturing cost, which is about 40% lower than other engines due to the reduced amount of parts. Furthermore, its streamlined design leads to reduced friction, enhancing overall efficiency and longevity (Lawes, 2002). The compact combustion chamber optimizes space utilization while ensuring efficient fuel combustion. Additionally, the engine's thermal distribution system helps regulate temperature effectively, enhancing performance and reliability. The RCV Engine also requires low maintenance making it a cost-effective and user-friendly option. As quoted by Keith Lawes in the article *The Rotating Cylinder Valve 4-Stroke Engine A Practical Alternative*, “The RCV offers significant benefits over conventional designs. In particular, it has the emissions performance and durability of a 4-stroke engine, with the effective power output and cost of a 2 stroke” making it a highly desirable choice for various applications.

## 2.5 Drawbacks of RCV Engine Design

Despite these benefits, there are some notable drawbacks to the RCV design. The first main problem with this type of engine is the sealing surfaces between the inner cylinder ports and the shell's ports.

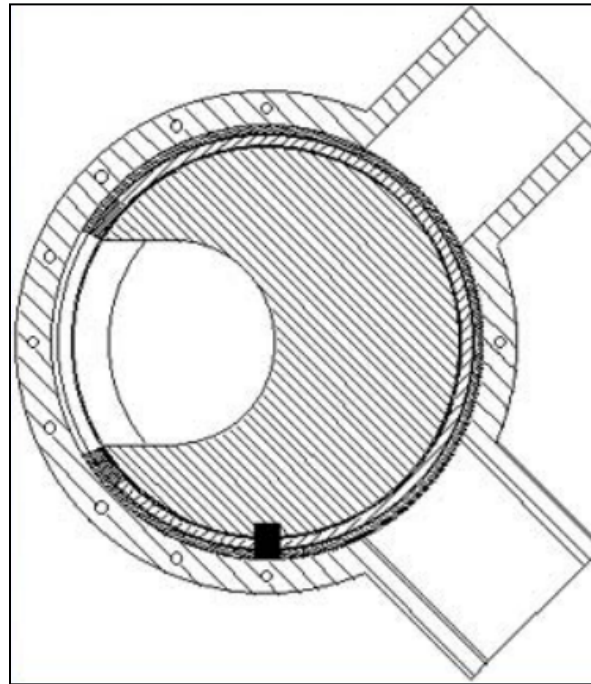

Figure 6: Rotating cylinder valve spring seal system (Lawes, 2002).

RCV Engines Ltd. used a sprung sealing mechanism to tackle the problem regarding the cylinder shell's ports. In order to mitigate the complex issue of sealing a surface that is rotating so rapidly, they designed a seal that uses spring force to expand to the outer surface. This design works well, but it introduces extra friction as well as torque losses, which depletes the efficiency and output of the engine overall.

Another issue with the RCV engine is the cooling system. Because there is no room for cylinder jackets or coolant circuits, it relies solely on air cooling to regulate the engine's temperature. Using air cooling reduces the number of components required in the design, but also sacrifices some reliability in cooling efficiency. With the main application of the RCV engine being aircraft, the engine's cooling fins are typically covered with a cowling. This reduces the amount of airflow the engine gets and thus reduces cooling efficiency. Despite these issues, however, the RCV engine still offers a significant amount of benefits when compared to a traditional valvetrain engine.

## 3.0 Methods

### 3.1 Reverse Engineering

The first step of our project was to reverse engineer the original design of the RCV-90 engine. We analyzed the components and operations of the engine to gain an understanding of the inner workings of the RCV-90. As seen in Figure 7, we disassembled the RCV-90 engine so we could get an in-depth look at each of the individual parts.



Figure 7: RCV-90 engine, disassembled.

This process allows for the identification of areas where improvements can be made, whether it is enhancing fuel efficiency, optimizing power output, or increasing reliability. As the team analyzed the inner workings of the engine, we were able to learn more about the engine's design, functionality, and performance characteristics. This helped us have a better understanding of what our design would be and how we could make the engine more efficient.

### 3.2 Component Selection

After completing the reverse engineering process, the team was able to create a list of all necessary components, separated by those that needed to be bought and those that needed to be machined from stock. In order to limit tolerancing errors and compression loss, we purchased internals from the DZ160 engine, a model plane engine designed by YS Engines. The internals the team purchased were the piston head, piston wrist pin, piston ring, connecting rod, crankshaft, and inner cylinder liner. These components are a key part of the team's RCV-160

engine, as they served as the base for the geometry of the internal mechanism. From the YS DZ160 engine, we calculated our engine's displacement would theoretically be 1.60ci, or 26.2cc.

### *3.2.1 Gear Selection*

The main operating principle of the RCV engine works thanks to the 90° bevel gears. These gears allow both the transmission of rotation between the crankshaft axis and the cylinder axis, but also ensure the 2:1 gear ratio necessary to the four-stroke cycle. The team found and purchased a ground spiral bevel gear pair from KHK Gears, the SBSG2-4020R and the SBSG2-2040L. The gears were chosen based on the diameter of the inner edge of the teeth – these were the smallest gears that could still fit the crankshaft inside them at the correct spacing. However, the team was unable to find a pre-manufactured gear with the correct bore and hub dimensions that could be directly applied to our RCV-160. The team contacted KHK for an estimate on having them custom-machine the gears, however, due to price, we decided to machine the gears ourselves. Figure 8 shows images of both of these gears before any machining, as they arrived from KHK.

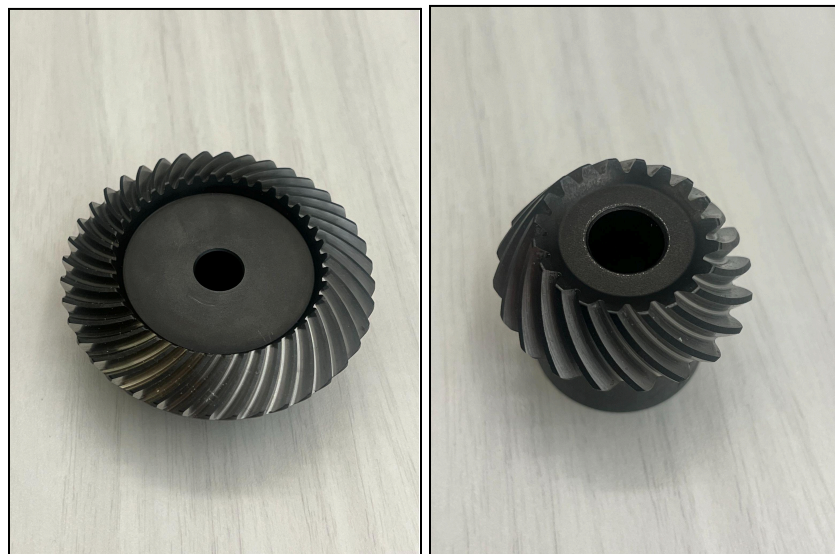

Figure 8: Cylinder gear (left) and crank gear (right).

### *3.2.2 Gear Material*

Another important consideration was the material of the gears. The team concluded that the steel quality for the gears should be S45C (by Japanese Industrial Standard), 1045 steel (by American Iron and Steel Institute standard), or something comparable, due to its good machinability for processes like tapping, milling, drilling, and sawing. The teeth of the gear are

also case-hardened, providing maximum surface hardness and wear resistance while simultaneously providing interior toughness to resist shock.

After receiving the gear parts, the team promptly arranged a meeting with Professor Thomas Christensen, the new director of the Center for Heat Treating Excellence (CHTE). With over two decades of expertise in thermochemical surface engineering and heat treatment of metallic materials, Professor Christensen was the ideal professor to consult regarding the machining of our gears.

During our discussion with Professor Christensen, we wanted to determine the machinability of the gears, as well as inquire about the necessity of heat treatment after machining. If the whole gear was hardened, the team would have to heat treat and anneal the gears to relieve internal stresses, soften the metal, and improve machinability. After he examined the gears in person, he concluded that only the teeth were hardened, meaning the rest of the gear was machinable. He proposed we perform a hardness test at Washburn to confirm that the rest of the gear is fully machinable.

Once we obtained more of the parts, we set up a meeting with the lab staff at the Washburn Shop to inquire about the process of machining the parts. Since we had limited experience with Computer-Aided Manufacturing (CAM), we reached out to some of the teaching assistants to ask for help in creating the CAM files and how we should approach the machining process for each part. After we discussed the steps we would take to cut and bore the gears down, we performed the hardness test that Professor Christensen mentioned to verify that the gear would be millable. We conducted a basic qualitative hardness test, using a file to grind part of the gear. The scrape that the file left behind indicated that the gear would be machinable.

### 3.3 Measuring

To accurately find the measurements of the existing engine parts, several group members took individual measurements, the averages of which were used in the modeling. This strategy mitigates the likelihood of measurement errors and ensures accurate measurement of critical engine components. Tables 3.1 through 3.3 show the individual and average measurements of the piston rod, piston head, and crankshaft, which are pictured in Figure 9.

Table 3.1: Piston rod measurements (mm).

	MIKE Z.			JIWON S.		
Small Hole $\varnothing$	7.00	7.00	7.02	7.04	7.03	7.04
Large Hole $\varnothing$	9.03	9.05	9.04	9.07	9.08	9.05
Distance	37.95	37.97	38.01	37.94	38.02	37.97
	JACK P.			MOLLY V.		
Small Hole $\varnothing$	7.01	7.00	7.02	6.98	7.02	6.96
Large Hole $\varnothing$	9.05	9.02	9.05	9.05	9.05	9.05
Distance	38.00	38.05	38.02	38.02	38.03	38.01
	JAMES R.			AVERAGE		
Small Hole $\varnothing$	7.04	7.03	7.00	7.013		
Large Hole $\varnothing$	9.04	9.02	9.05	9.046		
Distance	38.00	37.98	37.95	38.00		

Table 3.2: Piston head measurements (mm).

	MIKE Z.			JIWON S.		
Hole $\varnothing$	7.04	7.05	7.02	6.98	6.99	7.01
Distance	5.34	5.27	5.38	5.27	5.28	5.27
	JACK P.			MOLLY V.		
Hole $\varnothing$	7.00	7.01	6.99	6.98	6.99	7.01
Distance	5.30	5.28	5.29	5.27	5.28	5.27
	JAMES R.			AVERAGE		
Hole $\varnothing$	7.04	6.96	6.94	7.00		
Surface-Hole Distance	5.32	5.29	5.31	5.29		



Table 3.3: Crankshaft measurements (mm).

	MOLLY V.				JIWON S.	
Center $\varnothing$	3.96	3.99	4.01	4.01	4.01	4.00
Nub $\varnothing$	8.90	8.91	8.89	8.95	8.96	8.93
Center Distance	1.49	1.52	1.55	1.52	1.62	1.62
Nub Distance	18.60	18.58	18.61	18.55	18.64	18.65
	JAMES R.			AVERAGE		
Center $\varnothing$	3.99	4.03	4.02	4.00		
Nub $\varnothing$	8.89	8.84	8.90	8.90		
Center Distance	1.52	1.54	1.51	1.54		
Nub Distance	18.60	18.63	18.63	18.61		



Figure 9: Piston rod (top left), piston head (top right), and crankshaft (bottom).

The measurements from tables 3.1-3.3 were all able to be obtained with a digital caliper. However, some of the distances needed for the modeling needed to be calculated from these values, instead of measured. A recurring feature on multiple parts that needed such calculation was the center distance between two holes cannot be accurately measured with a caliper. Instead, the inner distance between is added to the radius of both holes. For the piston rod, this calculation resulted in a hole distance of 46.02mm. The piston head used this method to calculate the normal distance between the center of the side hole and the top surface, which came out to 8.79mm. Lastly, the nub-to-center rim distance and the nub center-to-center hole center distances from the crankshaft were measured, which came to 8.16mm and 14.61mm respectively.

### 3.4 CAD

Once the measurements of each component were completed and documented, we began the computer-aided design (CAD) process in Solidworks. This was a complex process that required careful measurement, design intent, organization, and mechanical skills.

The first step of the CAD process was creating a functional model of the RCV-90 engine. This ensured a deep understanding of each specific component as well as the overall mechanism and its inner workings. The team split into three groups of two people to tackle sections of the engine. Two members modeled the inner cylinder and the shell, two modeled the inner and outer crankcase, and two modeled all of the engine internals.

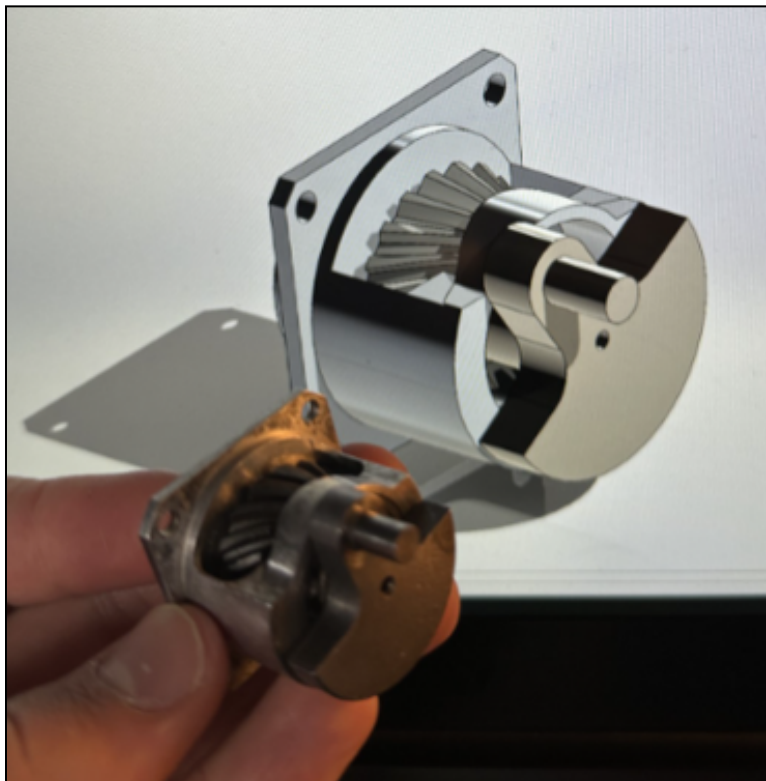

Figure 10: RCV-90 inner crankcase CAD.

Using these CAD models, the team was able to understand how the RCV-90 engine functions, and used the working assembly as a tool to understand how our engine's design would work. Each mate between surfaces needed to be defined carefully to reflect the proper operating condition of the engine.

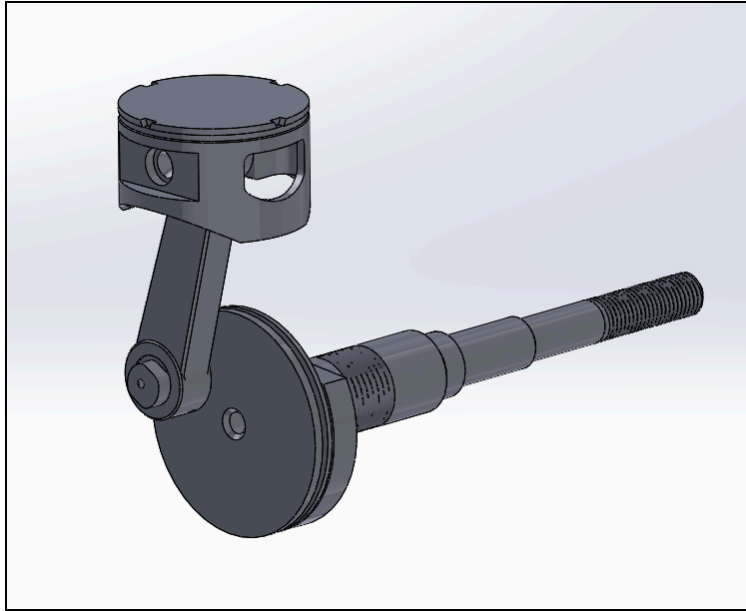

Figure 11: YS-160 DZ engine internals CAD.

As discussed in section 3.3, the measurements were a crucial part of the engine's design. Using these measurements we generated, the team created a working CAD model of the engine's internal components. This assembly then became the base for our full-engine assembly.

The next CAD model, which defined the geometry of our engine components, were the bevel gears. The solidworks models were imported from the gear manufacturer, KHK Gears, and a functional model was created using the datasheets from the KHK Gear's website. From there, the first challenge was modifying the gear to fit our engine's needs.

The large bevel gear required a considerable amount of modification in order to work in our RCV engine. The two main features that needed to be changed were a large hole for the piston and connecting rod to fit through, and a way to attach the rotating inner cylinder to the gear. To solve this problem, an indented cutout was created on the back of the gear surface, and on the front, we created counterbored holes for screws to fit through to mount the cylinder.

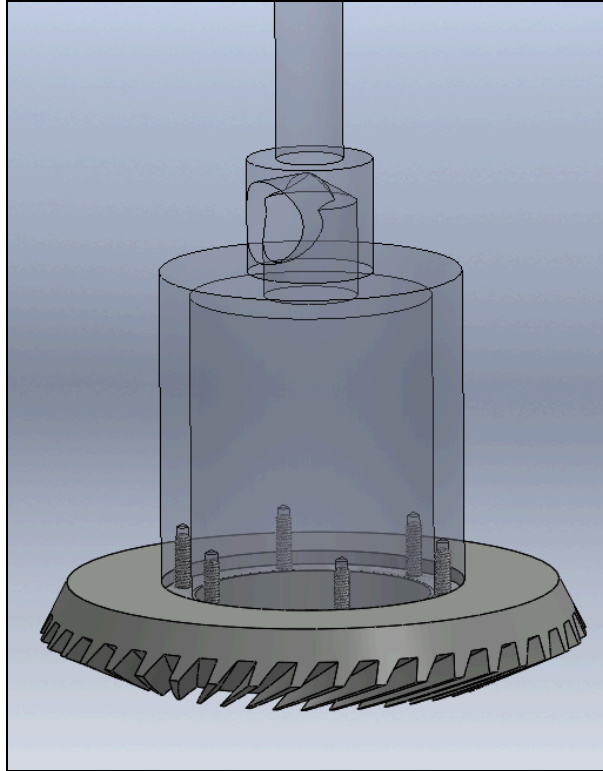

Figure 12: Inner cylinder and gear attachment detail view.

To connect the gear to the inner cylinder, 6 mil-spec alloy steel bolts were used. The models for these bolts came from McMaster-Carr along with the other hardware models which were used in our overall assembly.

The next part that was designed was the inner crankcase. This component used the small bevel pinion model from KHK Gears, as well as 2 bearings that came from McMaster-Carr as well. The CAD models provided by the component suppliers aided the design process greatly. In order to fit the crankshaft into the bevel pinion, we needed to reduce the diameter of the main shaft. We also needed to cut a slot for a key to fit inside, so that the pinion and crankshaft would rotate as one fixed component.

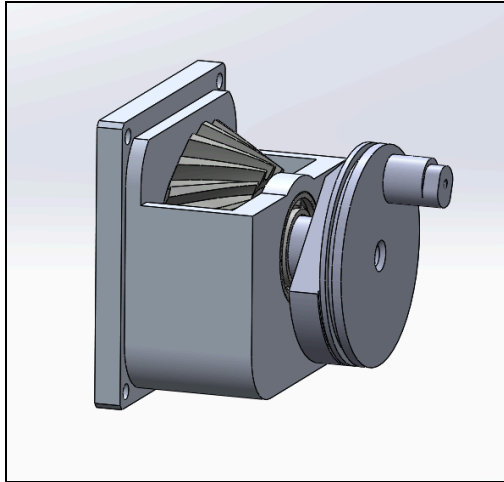

Figure 13: Inner crankcase assembly.

To continue, the next part that was designed was the outer crankcase. This part needed to be able to fit the large bevel gear as well as the inner crankcase, and serve as the structural base for the entire RCV Engine. It was designed with mounting holes for both the inner crankcase and the outer cylinder shell.

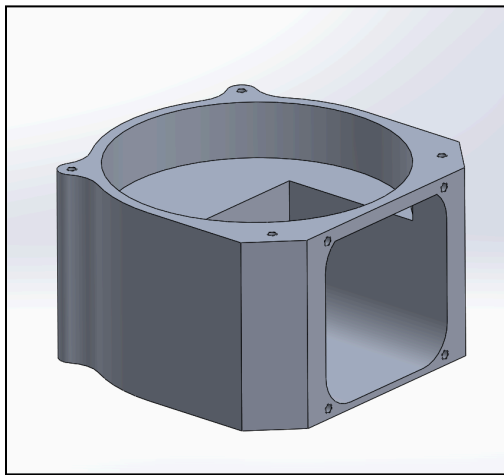

Figure 14: Outer crankcase component.

At the top end of the engine, the final two parts to be designed were the inner cylinder and the cylinder shell. These two parts went through iteration processes due to machining limitations in Washburn shops. The tolerances on the seal between the inner cylinder and cylinder shell needed to be carefully monitored due to the precise and airtight nature of the RCV's port design. A reamer was used to machine this hole precisely so that the dimension could be controlled accurately.

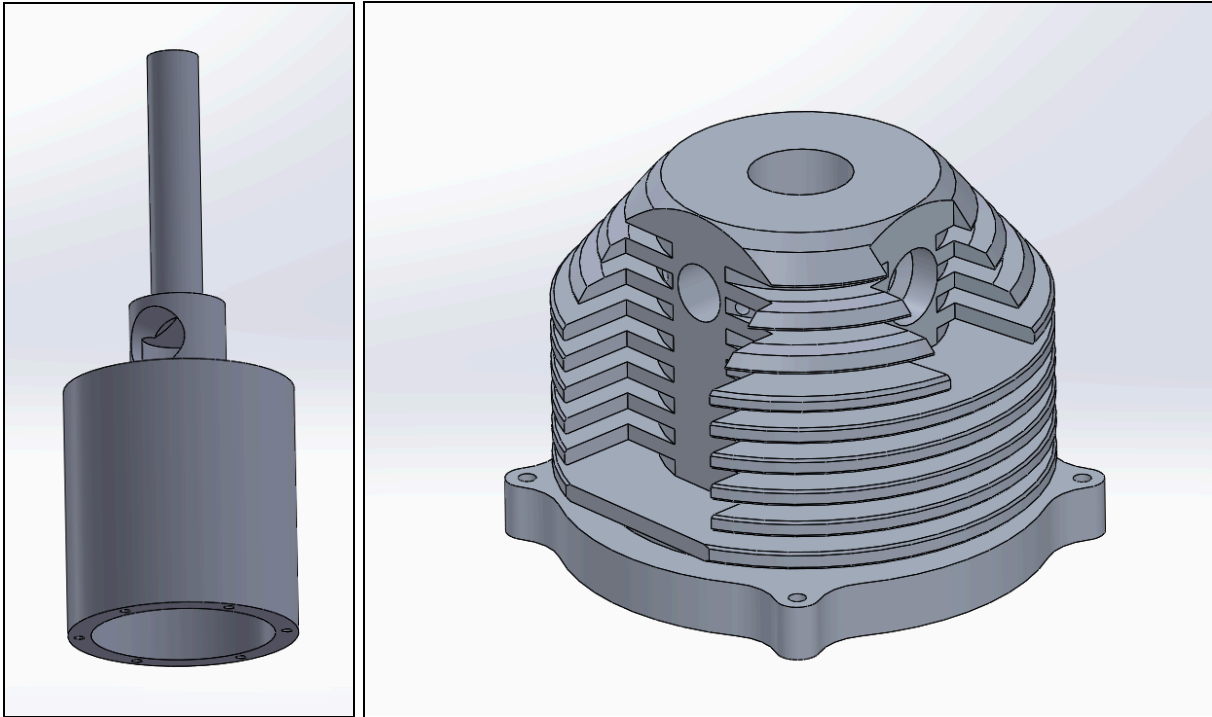

Figure 15: Inner cylinder (left) and outer cylinder Shell (right).

Many complex features needed to be created on the cylinder shell due to the amount of parts being attached to it. Working closely with the Washburn staff to understand the capabilities of the machine shop, the design was modified. The gaps between the cooling fins were not allowed to go below a certain size, the holes needed to be in certain positions and at certain angles, and the slots for the various other components needed to be designed to work with specific end mill tools available on the machine tools. Careful measurements of the spark plug, carburetor, and exhaust pipe were conducted in order to ensure a good fit between components.

Once the design of each part was completed, an assembly was created of all of the parts to study the motion, fit, and functionality of each component in the engine as well as the overall mechanism.

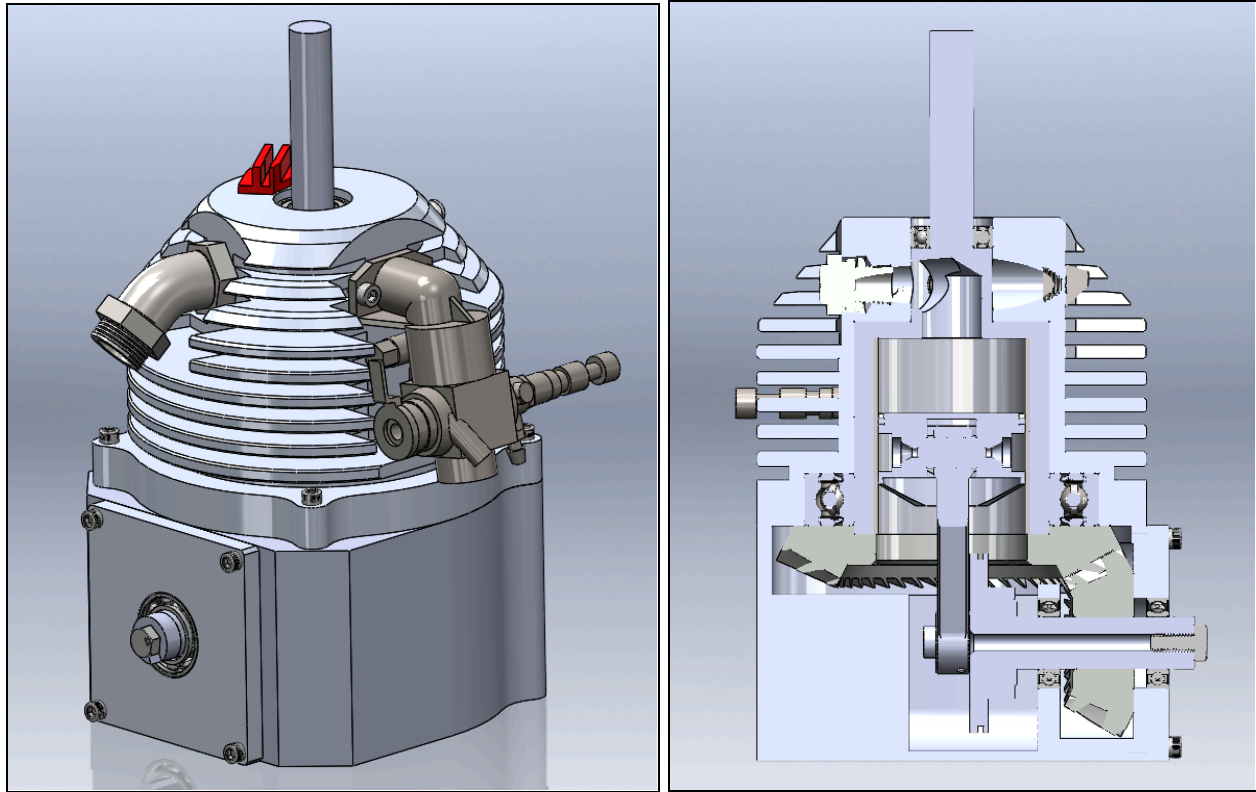

Figure 16: Full engine assembly (left) and full engine cross-section view (right).

### 3.5 Design Analysis

In order to validate the design, a number of analysis methods were employed. To accomplish this, the team used Solidworks' analysis tools on both individual components as well as the full engine assembly.

To begin, a thermal study was conducted on the cylinder shell to validate the cooling fins' functionality in cooling off the engine. In this study, the internal surfaces of the shell were set to a reasonable operating temperature for an internal combustion engine which was determined to be 185°C. A thermal convection coefficient of  $100 \frac{W}{m^2K}$  with a bulk ambient temperature of 7°C was used to simulate the use condition of a plane. These values were determined using the approximate altitude and operating speed of most RC planes that use internal combustion engines of about this size.

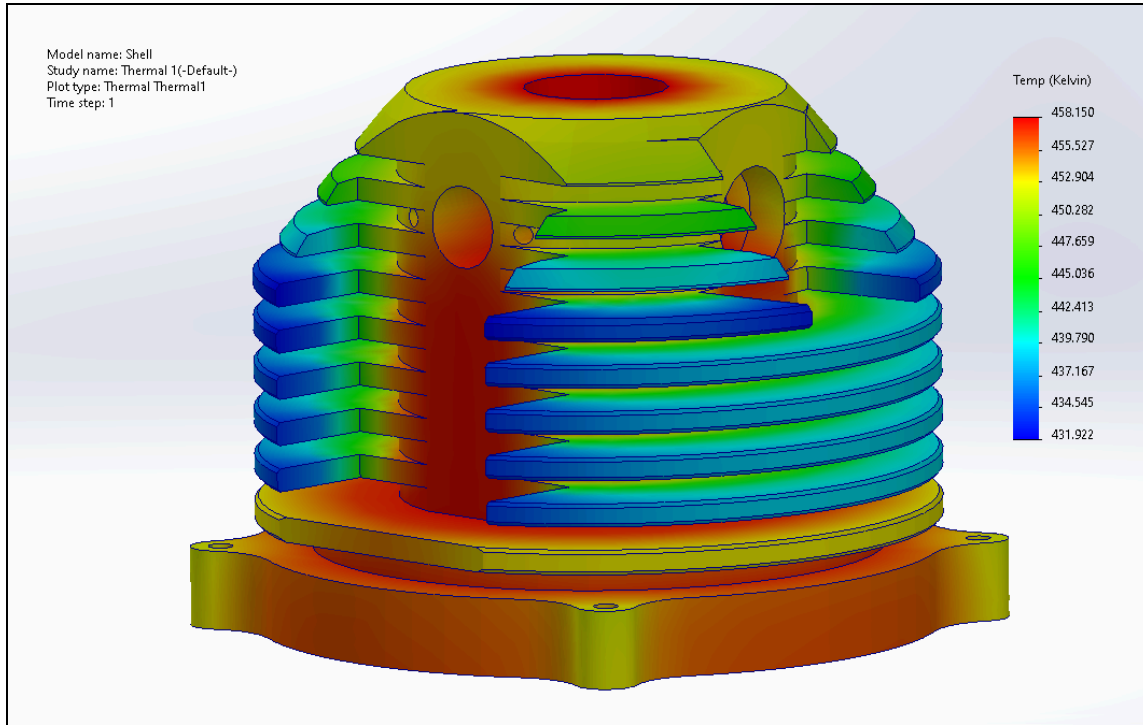

Figure 17: Cylinder shell thermal study results.

As shown by the results of this thermal study in Figure 17, the cooling fins on the cylinder shell were able to reduce the temperature by a maximum of about 30°C. Using the thermal expansion coefficient of 6061 aluminum allows for the material to expand without creating a collision with the inner cylinder. It is important to make sure the cooling fins radiate heat properly, as this is the only feature of the engine that regulates its temperature.

Using some of Solidworks' other tools, the engine's hole alignment and interference detection were calculated. After running these studies in Solidworks, we were able to verify there were no misaligned holes and no interferences between parts in our assembly. Once these analyses were finished, the team moved on to designing the manufacturing processes for these components using CAM software.

### 3.6 Computer Aided Machining

The team used Fusion 360 as the Computer Aided Machining (CAM) program to program the CNC machines. The three basic machining operations used were milling, basic turning, and live turning. The inner crankcase, outer crankcase, and large bevel gear were machined using milling operations on the Haas Mini Mill. The crankshaft, combustion cylinder, and shell were machined using turning operations on the Haas ST10.



### 3.6.1 CAM Milling Operations

To create the CAM operations, the team first imported the CAD design for the engine into Fusion 360. For the internal machining of the piece, the team used 2D pocketing operations, adaptive clearing operations (shown in Figure 18), contour operations, facing operations, and drilling operations. For each of these operations, the team selected the largest possible tool for the job, cutting down on machining time and minimizing the possibility of breaking the tool during the operation. Although the CAM program is able to automatically generate the tool path, the team then needed to make adjustments to ensure a successful machining process. The first adjustment made was importing the proper feeds and speeds rates for the tool based on the materials. Because of the material properties of aluminum and steel, the feed and speed rates needed to be set higher on the aluminum parts than on the steel parts. Figure 19 shows the feed and speed values for the steel operation on the large bevel gear. The second adjustment the team made was programming multiple depths for each operation. By using multiple depths, the tool incrementally cuts into the stock. Although this increases the overall machining time, it does greatly diminish the possibility of damaging the tool. Figure 20 shows what the difference between these tool paths looks like. The last adjustment the team made to the milling operations was to cut the stock. When CAM generates a tool path, it leaves a fraction of the stock and the intended dimensions created in CAD. By cutting to stock, the tool will cut the intended dimensions exactly.

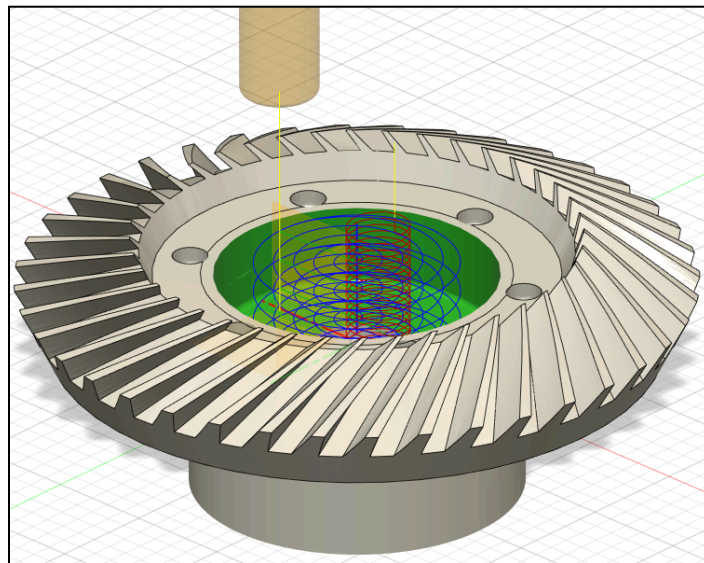

Figure 18: Adaptive clearing operation tool path generated in Fusion 360 for the large gear .

▼ Feed & Speed	
Preset	Custom ▼
Spindle Speed	3055.77 rpm
Surface Speed	300 ft/min
Ramp Spindle Speed	3055.77 rpm
Cutting Feedrate	18.3346 in/min
Feed per Tooth	0.002 in
Lead-In Feedrate	18.3346 in/min
Lead-Out Feedrate	18.3346 in/min
Transition Feedrate	18.3346 in/min
Ramp Feedrate	50.4 in/min
Plunge Feedrate	8.4 in/min
Plunge Feed per Re...	0.00274889 in

Figure 19: Custom feeds and speeds for milling operation on the steel bevel gear.

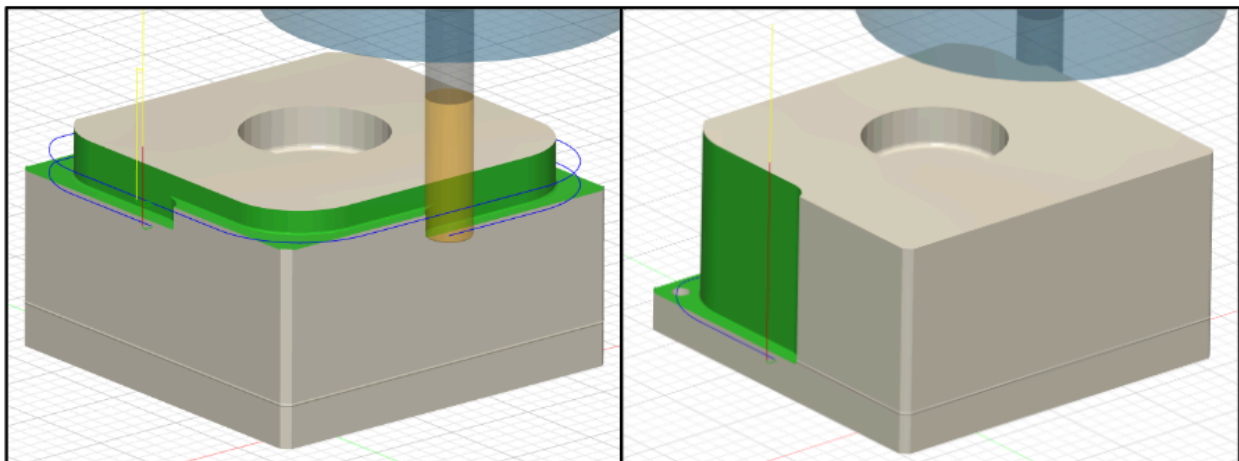

Figure 20: Comparing using multiple depth (left) and not using multiple depth (right).

### 3.6.2 CAM Turning Operations

To create the turning operations for the crankshaft and the outer shell, the team imported the CAD designs into Fusion 360. Once imported, we selected a cutting tool to cut down the diameter of the crankshaft arm. After the CAM was generated for the operation (shown in Figure 21), we changed the feed and spin rates to match the material. Finally, the team created a finishing operation to cut down the excess stock and leave a smoother surface. The second turning operation was a live tooling operation. In customary turning operations, the piece being machined spins, while the tool is stationary. In live tooling operations, the tool also spins. The live tooling operation was used to machine the combustion cylinder and the outer shell. To create the CAM program for live tooling, the staff at Washburn Laboratories requested they be allowed to create the program themselves to ensure the Haas ST10 does not break during operation.

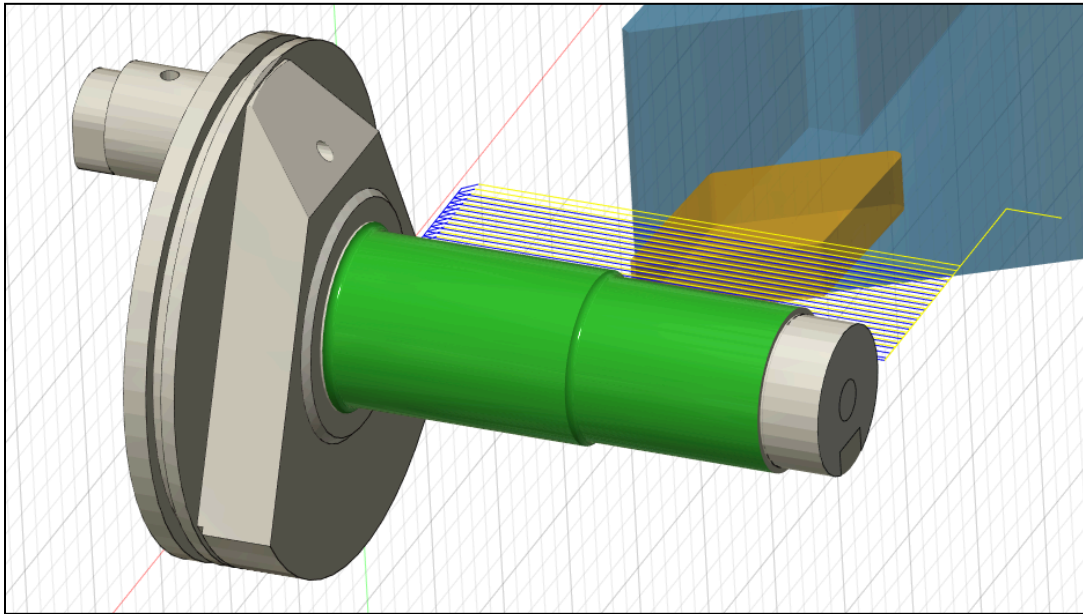

Figure 21: Turning operation generated in Fusion 360 for the crankshaft.

After creating the CAM program to machine the parts, the team met with teaching assistants and lab monitors at Washburn Laboratories. The staff helped review the CAM operations and make suggestions on increasing dimensions, changing tools, changing milling operations, and helping/supervising the actual machining of our engine. They also notified the team of the specific machine tools we would need to purchase to complete the more complex and specific operations.

## 3.7 Machining

### 3.7.1 Factor of Safety and Material Choices

Choosing the proper material is an important consideration to be made in a design like this. Heat expansion, friction coefficients, and strength under loads all change based on the material, and it is important to make sure that the machine will not fail at its operating conditions.

The RCV-90 and RCV-120 engines that the team had to reference used a steel cylinder and an aluminum shell. The shell is a larger part, with more total machining required because of the fins, so using steel would have made it harder to machine since it is a tougher metal. However, the cylinder experiences high loads, so aluminum could prove to be too soft a metal for the job. This is why the company that made the RCV-90 and RCV-120 engines used those metals. However, choosing two metals does create one more problem. Steel and aluminum have different coefficients of heat expansion, meaning when the temperature of the engine raises, the aluminum heat sink will expand faster than the steel cylinder, breaking the critically tight seal between the two parts. These engines used a creative solution to this problem. The inside of the shell is lined with a thin steel liner, which is press-fit into the shell, while also having an airtight seal with the cylinder. This means the airtight seal is still intact at high temperatures because the airtight seal is made between two pieces of steel instead of one piece of steel and one piece of aluminum.

The team, however, did not want to use this solution. A major challenge of this project was the limited access to machining equipment due to the partial shutdown of the machine shop at WPI. As a result, the team wanted to minimize the total amount of parts needed to create a successful engine. For the same reason, machining the shell out of steel would have been equally challenging. Making both the shell and the cylinder out of aluminum would make both the design and the production process significantly simpler. Because aluminum is weaker than steel, the team needed to ensure that the cylinder would be strong enough to hold at the operating conditions.

The following equations show the calculation for the factor of safety of an aluminum cylinder at the assumed maximum operational capacity of 8000 RPM and 2 horsepower. These values were determined based on similar values for other RCV engines (Lawes, 2002). The first

set of equations, shown below, are calculating the factor of safety at the threaded end of the cylinder, where the propeller would be attached.

#### Equation 1: Factor of Safety of the Prop End of the Cylinder

J = Moment of Inertia T = Torque P = Power  $\omega$  = Angular Velocity

$$J = \frac{\pi}{2}r^4 = \frac{\pi}{2}(0.005m)^4 = 9.82 * 10^{-10} m^4$$

$$T_{max} = \frac{\tau J}{r} = \frac{240MPa * 1.96 * 10^{-7} m^4}{0.005m} = 47.12 Nm$$

$$T_{expected} = \frac{P_{expected}}{\omega_{expected}} = \frac{2hp}{8000rpm} = \frac{1491.4 J/s}{104.719 rad/s} = 14.24 Nm$$

$$FoS = \frac{T_{max}}{T_{expected}} = \frac{47.12 Nm}{14.24 Nm} = 3.31$$

The below equations show the same calculation for the opposite end of the cylinder, where it connects to the bevel gear.

#### Equation 2: Factor of Safety of the Gear End of the Cylinder

J = Moment of Inertia T = Torque P = Power  $\omega$  = Angular Velocity

$$J = \frac{\pi}{2}r^4 = \frac{\pi}{2}((0.045m)^4 - (0.036m)^4) = 3.80 * 10^{-6} m^4$$

$$T_{max} = \frac{\tau J}{r} = \frac{240MPa * 3.80 * 10^{-6} m^4}{0.005m} = 182,540 Nm$$

$$T_{expected} = \frac{P_{expected}}{\omega_{expected}} = \frac{2hp}{8000rpm} = \frac{1491.4 J/s}{104.719 rad/s} = 14.24 Nm$$

$$FoS = \frac{T_{max}}{T_{expected}} = \frac{182,540 Nm}{14.24 Nm} = 12,818$$

These equations show that, at worst, there is a 3.31 factor of safety at the part most likely to break. This proves that aluminum is a strong enough material to be used for the cylinder, allowing the design to bypass the need for a steel liner between the cylinder and the shell.

### 3.8 Engine 4-Stroke Cycle Timing

In order for any internal combustion engine to run, the timing is a crucial component. The exact moment that the intake valve opens, the spark plug fires, and the exhaust valve opens are all extremely precisely timed and need to be optimized in order to maximize the efficiency of our

engine. To control the moment when each of these ports opened, the angle of the intake, spark, and exhaust ports were defined relative to each other.

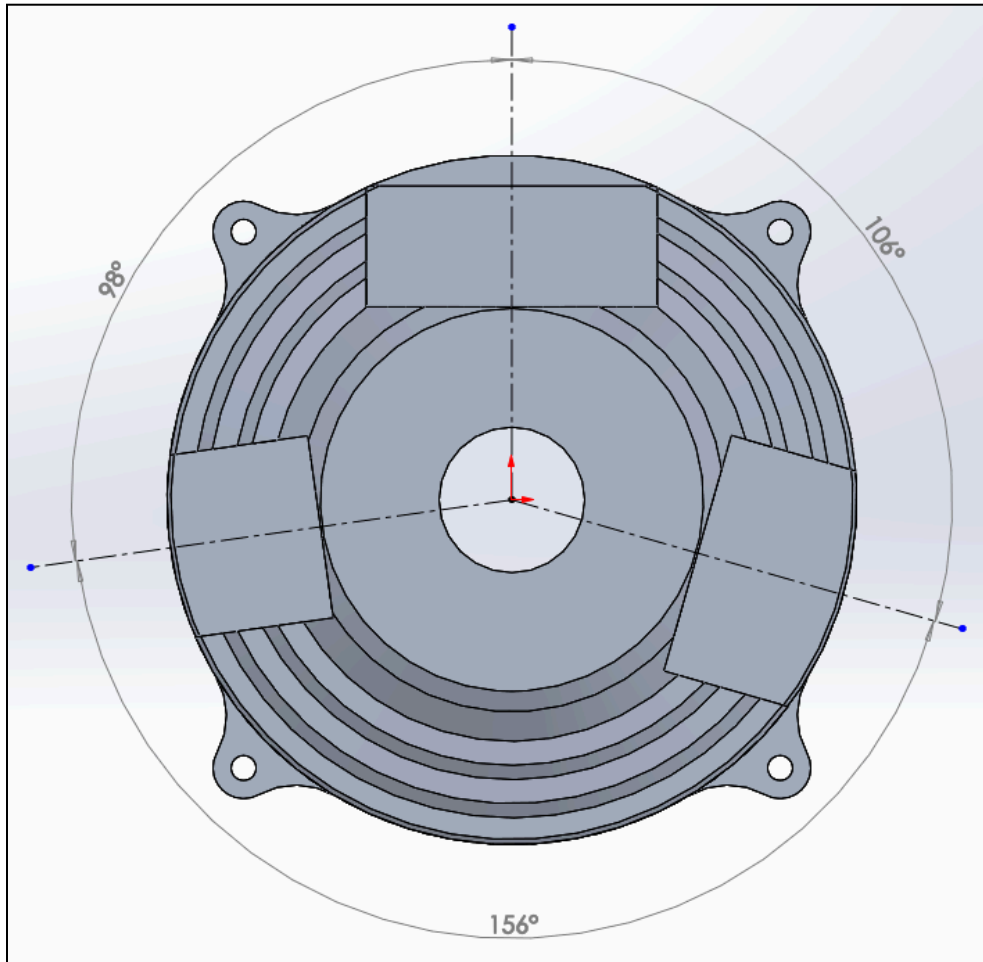

Figure 22: Cylinder shell port angles.

The above figure shows the port angles in our RCV-160 Engine Design. These angles were decided largely as a result of the reverse engineering the team conducted on the existing RCV-90 engine. It is important that the engine is able to conduct all 4 strokes of the 4 stroke cycle effectively to ensure proper operation.

One of the most important things regarding the timing of the 4-stroke cycle is the timing of the spark plug's firing. This was controlled by an RCAME automatic advance ignition module, which uses a hall effect sensor and a battery attached to the spark plug to control when it fires. To use a hall effect sensor to manage the timing of the engine, a small hole was implemented into the cylinder shaft, where a magnet was placed. A small plastic sensor mount was 3D printed so it can be held in front of the shaft for the magnet to pass it. The module works

by using the hall effect sensor as a switch. Every time the magnet passes in front of the sensor, the spark plug receives voltage and creates a spark. During assembly, the spark port must be aligned with the inner cylinder port's rotation at the moment of firing. If this condition is not satisfied, the spark plug will not combust the fuel, and the engine will not run.

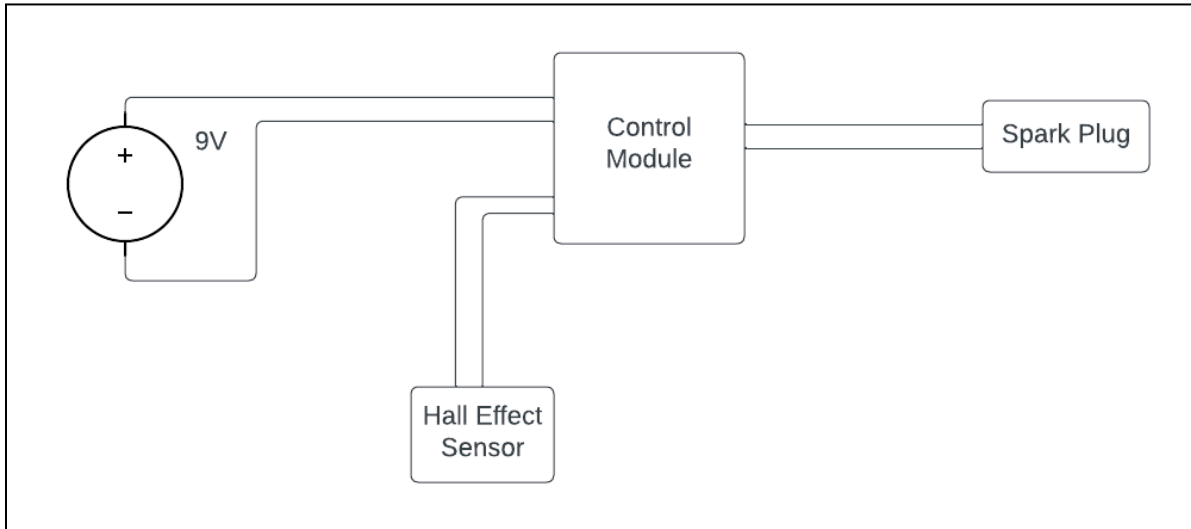

Figure 23: Ignition module circuit diagram.

Using this simple device, the RCV-160 engine's timing can be set manually upon assembly. Lining up the small magnet with the spark plug's port in the cylinder shell while assembling the engine, allows for the spark plug to fire exactly when the Hall effect sensor trips. It is necessary to note that the spark plug will fire as soon as the magnet leaves the sensor, not as soon as it is detected. This is crucial for set-up because if done incorrectly, the spark plug will not fire at the right time.

## 4.0 Results

The team was able to begin and complete the machining of the Outer Cylinder Shell (Figure 22). This was done with the assistance of the Washburn Staff. Upon completion, the team did a visual inspection of the shell to ensure the machining did not cause any damage to the piece that would interfere with the ability to assemble and run the engine. After the inspection was complete the team attempted to test the size of the ball bearing slots in the shell. The large ball bearing fit into place with a nice tough fit. The smaller slot on the top of the shell was a little bit tighter and would require using the reamer to finish the machining process the team purchased to fit into the slot. The team also decided to manually drill the mounting holes rather than during the machining process to save time and tool pieces. Due to the time constraints, the team was unable to machine any other parts of the engine.

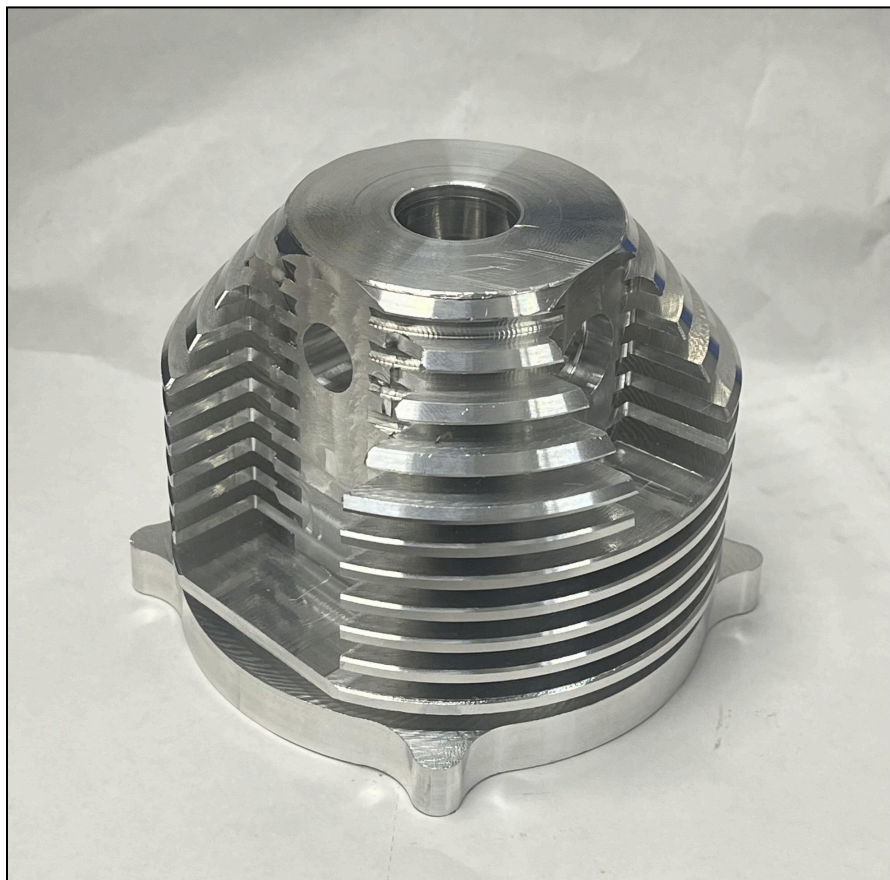

Figure 22: Mechined Outer Cylinder Shell

To analyze the results of the design and manufacturing process of the RCV-160 engine, the angular velocity and output horsepower can be measured and compared to the expected



values. In earlier calculations, mentioned in section 3.7.1, the high end of the expected values for these two measurements are 8000 rpm and 2 hp. Measuring the actual output of the engine, and comparing it to these values, will show how effective the final product was. These numbers were chosen based on measured angular velocity and power data from other RCV engines (Lawes, 2002).

In order to measure the brake horsepower, torque, and other performance metrics, a small engine dynamometer can be used. As the application for these types of small engine dynamometers is niche, research needs to be conducted to find a dynamometer which will properly suit the application of our RCV engine. The engine can also be weighed, which can be used to generate a power to weight ratio.

To measure the thrust output of the engine, a propeller can be attached. The engine with the propeller can be mounted to a load cell axially, which will measure the thrust force the engine generates at different throttle positions. This data could be analyzed and compared to that of other engines of similar size. This thrust value can also help to inform what type of aircraft this RCV-160 engine would be suitable for.

The angular velocity can be measured using a tachometer. A tachometer is a device that measures timing between reflective readings to calculate rotations per minute. A small piece of reflective tape can be attached to the crankshaft, allowing the tachometer to get a reading.

The functionality of the cylinder shell's heat sink can be measured using an infrared digital laser thermometer, taking measurements of heat dissipation after certain intervals of time during which the engine is run. A graph can be created based on the temperature after specific time intervals, which can be analyzed to determine what rate at which the cylinder shell is able to dissipate heat.

Basic mechanical operation and wear can be visually inspected after engine operation. After allowing the engine to reach peak operational temperature with multiple full-throttle to idle cycles the engine can be completely disassembled for visual inspection. The team can pay special attention to high-wear surfaces such as gear teeth and mating surfaces, piston walls, and rotating cylinder walls. The bearings can also be manually inspected for wear and functionality as these are crucial for proper engine operation. This process can also allow for the team to inspect the oiled surfaces and allow for re-oiling for reassembly.

The fuel consumption of the engine can also be measured. Fuel efficiency allows the team to measure how effectively the engine utilizes fuel to generate power. Fuel consumption is a function of throttle position and can be taken into consideration when measuring fuel efficiency. These values could be expressed in ounces of fuel by weight per minute of run time or (oz/min). Small RCV engines typically have very high fuel consumption when compared to other airplane engines.

## **5.0 Analysis and Discussion**

Our MQP team was able to design a model and manufacturing plans for a fully operational RCV-160 engine. Using the Solidworks design analysis tools, we were able to verify the fit for all the parts we drew in terms of clearance and tolerance as well as test the functionality of the parts through the assembly animation we created. This allowed us to visually and analytically examine the engine through Solidworks before manufacturing the parts to reduce mistakes and material costs.

Following the plans outlined in section 4, upon the manufacture and assembly of our engine, many metrics can be tested and analyzed. These results can be subsequently compared to the metrics of RCV engines found in our background sources to verify the functionality and potential improvement upon previous designs we were able to achieve.

The mechanical wear on specific parts like the gears, bearings, piston, and cylinder walls is an important design consideration which needs to be practically analyzed upon assembly and testing of the RCV-160 engine. Issues can form from the components not being lined up optimally, leading to a fit being too tight, or too loose compared to our initial, ideal design state created in solidworks. Another key factor is the material selection for the different parts that connect together, and if the parts were lubricated well enough. With a combination of wear resistance, frictional properties, and compatibility between the part's materials, there are several considerations that go into reducing the wear on the engine. These wear characteristics are key to be considered when evaluating the longevity and lifetime of the RCV engine. After measurement and evaluation of such properties, the design can be modified and improved.

## **6.0 Recommendations**

### **6.1 Manufacturing**

The team compiled an in depth file with all the pertinent information for a future group to continue the manufacturing and testing. The step is to review and learn about the RCV engine and how they work. The Solidworks design should be reviewed, becoming familiar with the intricate workings of the RCV Engine. This step is very important, as a good understanding of the engine's design is crucial to the success of the manufacturing process. After reviewing the solidworks design, use the fusion 360 program that our team created and the solidworks to update the machining program. The dimensions from both the solidworks and Fusion 360 were used to purchase the necessary materials for manufacturing. A comprehensive tool list has been created with all the tools currently needed for manufacturing, some of the tools are available in Washburn Labs but other more specific tools will need to be purchased. It is important to maintain regular communication with staff members at Washburn Labs to both check the Fusion 360 programs and assistance in machining the parts. Upon completing the manufacturing of the parts the engine must be assembled and move on to the testing phase, outlined briefly in this report's analysis section.

### **6.2 Testing**

One important recommendation to consider is needing to test various performance and efficiency metrics of the RCV-160 engine. While this was not something able to be accomplished during the completion of this project, high level plans are outlined for the testing and documentation of the engine in sections 4 and 5.

## References

- Electric motors*. (n.d.). Retrieved February 16, 2024, from [https://barnardmicrosystems.com/UAV/engines/rotating\\_cylinder.html](https://barnardmicrosystems.com/UAV/engines/rotating_cylinder.html)
- Gerould, B. (2023, February 8). *Is this the next great leap for internal combustion?* Hagerty Media. <https://www.hagerty.com/media/maintenance-and-tech/is-this-the-next-great-leap-for-internal-combustion/>
- Hendry, Maurice D. (1972). *"The Unholy Sage of the Silent Knight"*. Automobile Quarterly. Automobile Heritage Publishing. 10 (4): 401–413. ISBN 1-59613-139-X
- Jabari. (2014, October 21). PPT - *Camless Rotating Cylinder Engine PowerPoint Presentation*, free download - ID:5690526. SlideServe. <https://www.slideserve.com/jabari/camless-rotating-cylinder-engine>
- Jaguar Daimler Heritage Trust. (n.d.). Retrieved February 16, 2024, from <https://www.jaguarheritage.com>
- Lawes, K. (2002). *59 The Rotating Cylinder Valve 4-Stroke Engine A Practical Alternative*. SAE Transactions, 111, 2963–2975. <https://www.jstor.org/stable/44743308>
- Mason, B., Lawes, K., & Hirakawa, K. (n.d.). *Rotary valve 4-stroke engines for general purpose power ... Rotary Valve 4-Stroke Engines for General Purpose Power Equipment and Unmanned Systems*. <https://www.unmannedsystemstechnology.com/wp-content/uploads/2022/11/Rotary-Valve-4-Stroke-Engines-for-General-Purpose-Power-Equipment-and-Unmanned-Systems.pdf>
- Pimentel, D. (2021, January 12). *The Perfect Single-Engine Piston Airplane for You*. FLYING Magazine. <https://www.flyingmag.com/2020-buyers-guide-perfect-single-engine-piston/>
- R.C. Cross Motorcycles. (n.d.). *Classic Motorcycles at Sheldon's Emu*. Retrieved February 16, 2024, from <https://cybermotorcycle.com/euro/brands/cross.htm>
- Rotating Cylinder Valve (RCV) engine unveiled*. (2006, February 2). New Atlas. <https://newatlas.com/rotating-cylinder-valve-rcv-engine-unveiled/5139/>
- Sparkes, M. (2021, September 29). *Drones are "sniffing" ship exhaust for illegal fuel in European waters*. New Scientist. Retrieved March 20, 2024, from <https://www.newscientist.com/article/2291570-drones-are-sniffing-ship-exhaust-for-illegal-fuel-in-european-waters/>

*UAV engines - heavy fuel 4-stroke drone engines for UAS: RCV Engines.* Unmanned Systems Technology. (2024, March 6). <https://www.unmannedsystemstechnology.com/company/rcv-engines/>

Yarrish, G. (n.d.). *A rotating-cylinder-valve 4-stroke.* RCV 120-SP. <https://sceptreflight.com/Model%20Engine%20Tests/RCV%20120-SP.html>

# **Appendix A: Engine Safety and Running the Engine**

**RCV DOs and DONTs, section 2 of RCV-120 manual, RCV Engines Ltd.**

## **ENSURE YOUR ENGINE IS FIRMLY MOUNTED**

The larger than normal torsional forces from the geared prop mean the engine must be very securely mounted to the fuselage or test stand. Fuselage construction around the engine mount must be very rigid (bear this in mind when choosing a model) and test stands must be substantial.

## **ALWAYS USE BEHIND THE PROP STARTING**

Your engine comes complete with a starting adapter. We advise and strongly recommend that the unique benefit of behind the prop starting is taken advantage of at all times. When using this starting method a good high-powered electric starter will be necessary. Do NOT use a drill as this can cause damage to the engine. Please ensure the connections to the starter are reversed (SEE SECTION 4).

## **ALWAYS USE A REMOTE GLOW CONNECTOR**

Do not use a conventional clip-on glow connector. The glow plug is far too near the prop for its safe use.

## **ONLY USE RECOMMENDED FUELS**

We recommend you use a methanol based fuel containing 10% Nitro. We recommend Weston Uk Liquid Gold Prosynth 2000 10% nitro fuel. For more information on fuels please see SECTION 3.

## **ONLY USE RECOMMENDED PLUGS**

We strongly recommend the use of a Pro plug PP4T plug. Fitting a non recommended plug may produce a significant drop in performance when the glow battery is disconnected.

## **USE ONLY COARSE PITCHED PROPS**

Propeller pitches would normally be between 12 and 14 inches. Do not use a propeller with a pitch less than 10. (SECTION 3)

#### SET UP THE CARBURETTOR CORRECTLY

As supplied the idle needle is set at rich to protect the valve. To achieve smooth running this must be adjusted as per instructions (SECTION 5)

#### ENSURE THE EXHAUST IS PROPERLY TIGHTENED

Prior to use, tighten the exhaust pipe and muffler using the recommended procedure in SECTION 2

#### ENSURE ADEQUATE COOLING

The streamline nature of an RCV engine makes for a neatly cowled installation, however provision for cooling ducts must be provided.

**Appendix B: Individual Engine Solidworks Part Views**

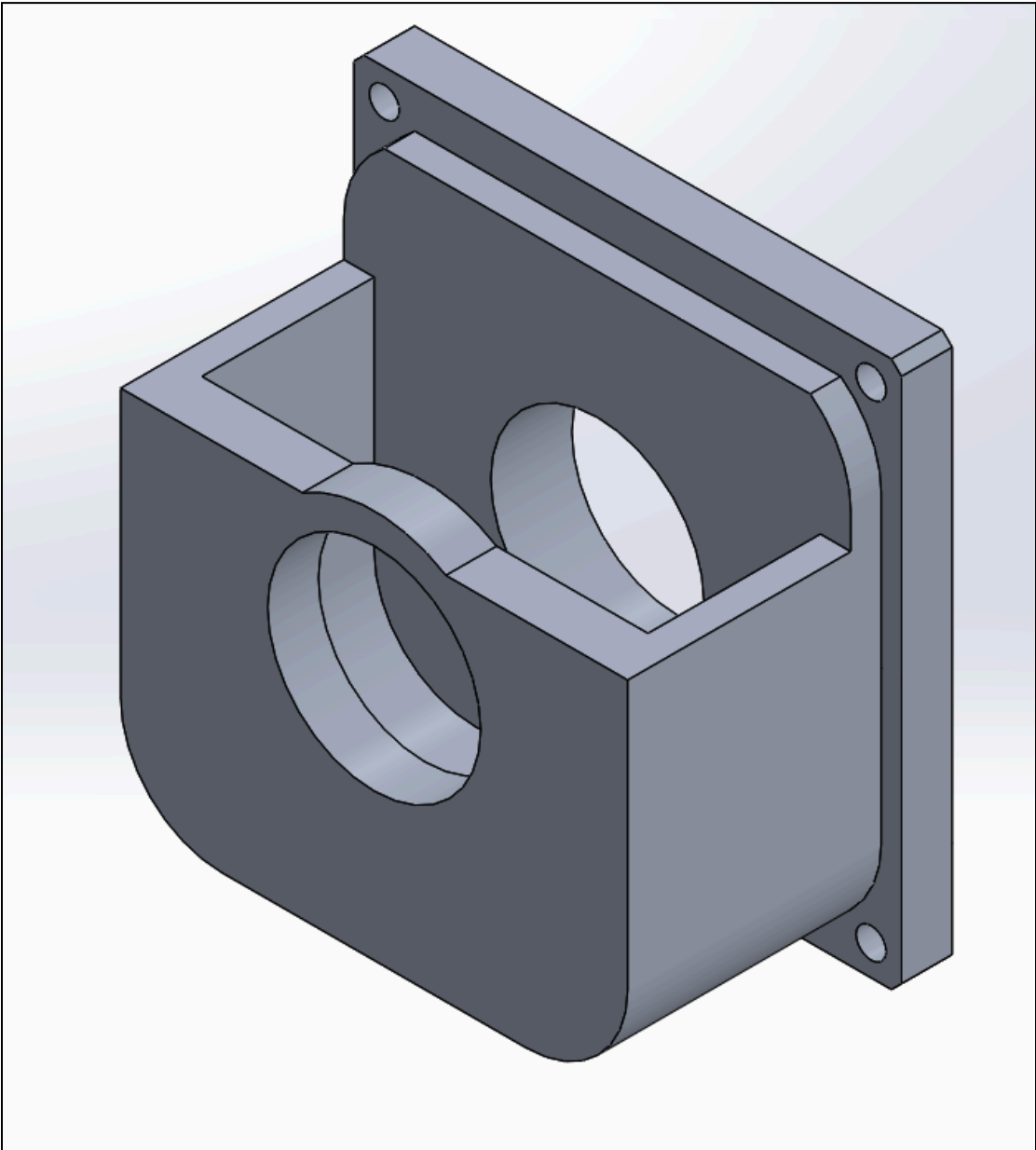

Inner Crankcase



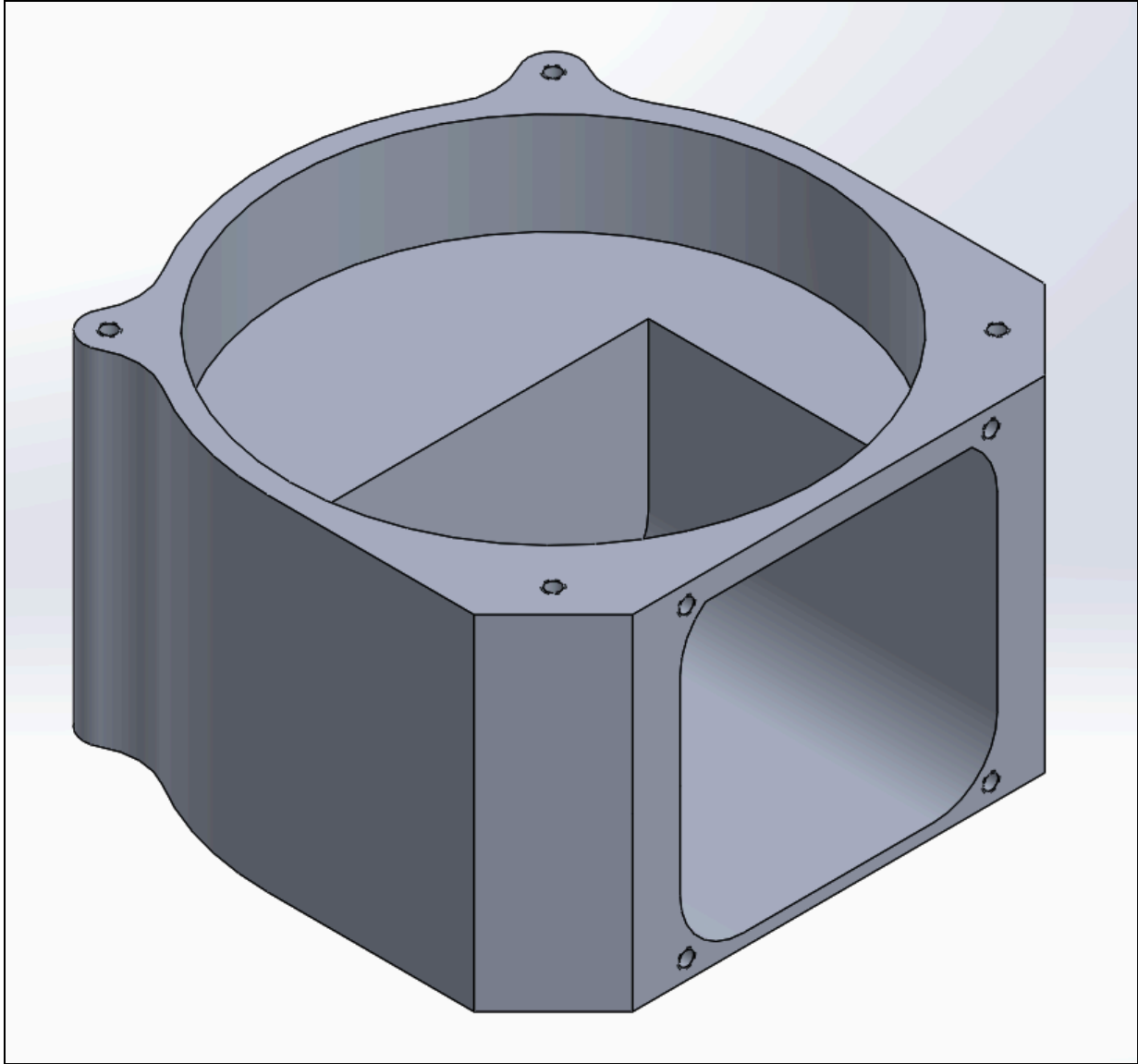

Outer Crankcase

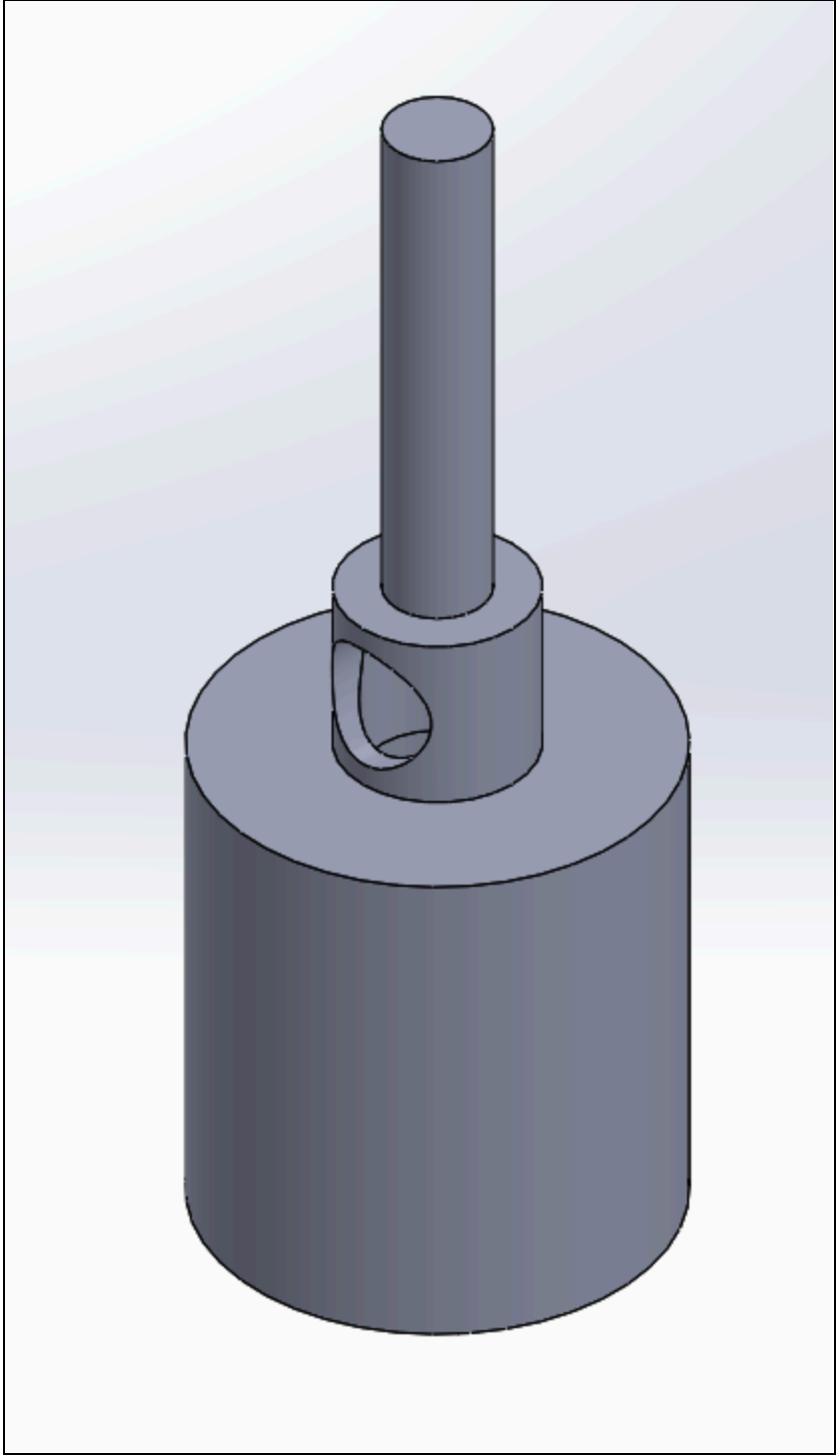

Inner Cylinder

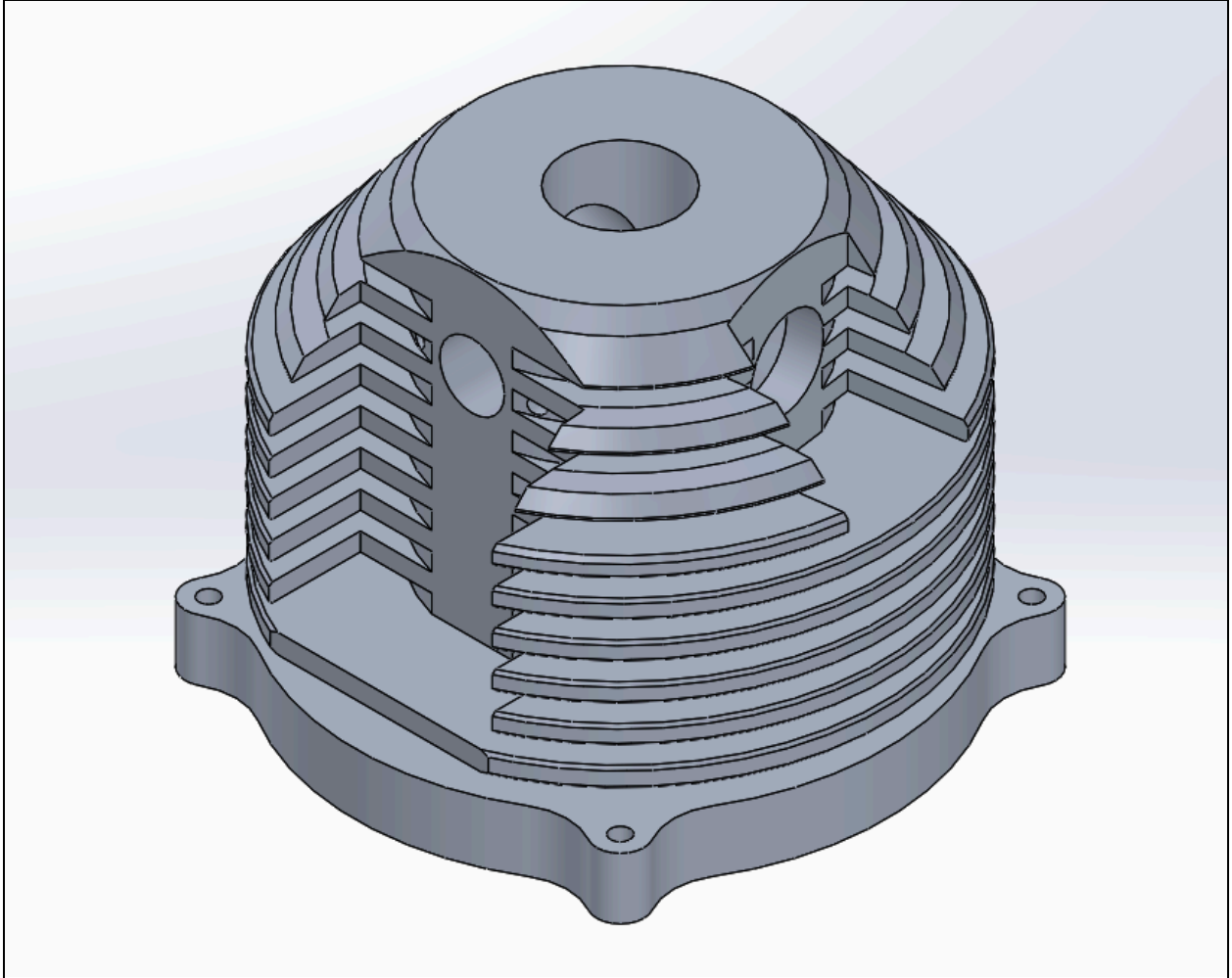

Cylinder Shell

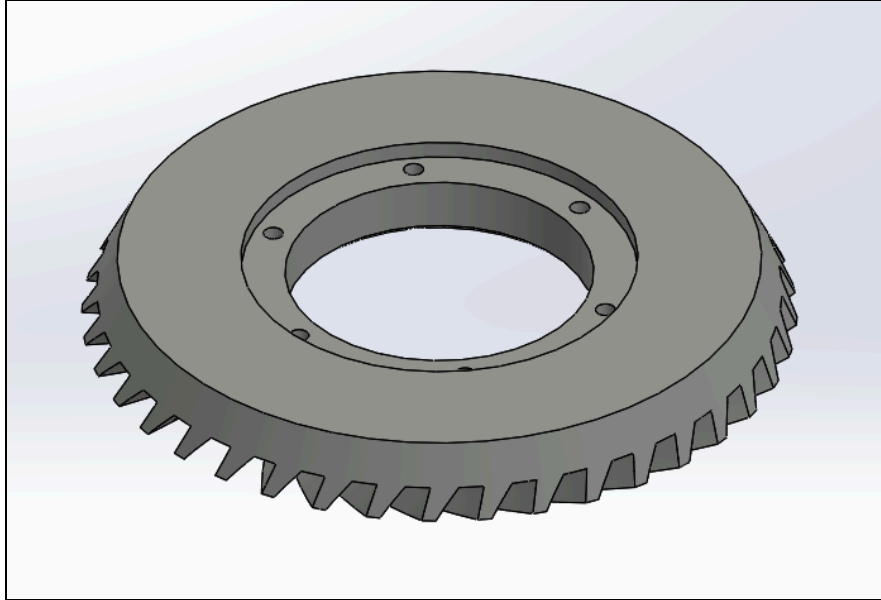

Large Cylinder Bevel Gear

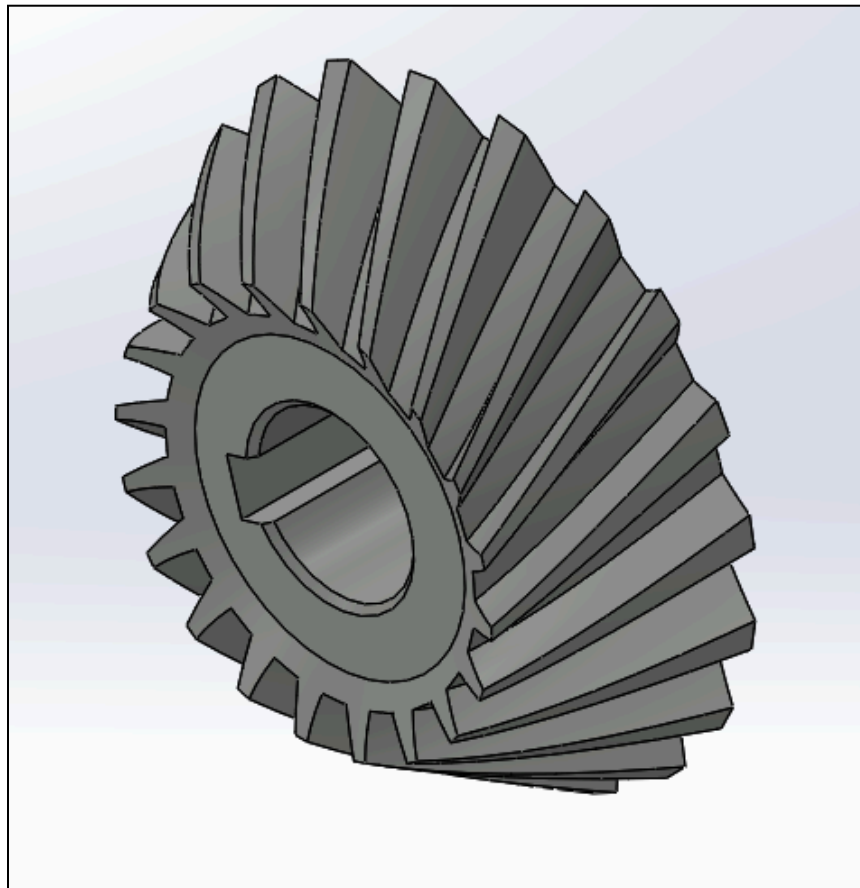

Small Crankshaft Bevel Pinion

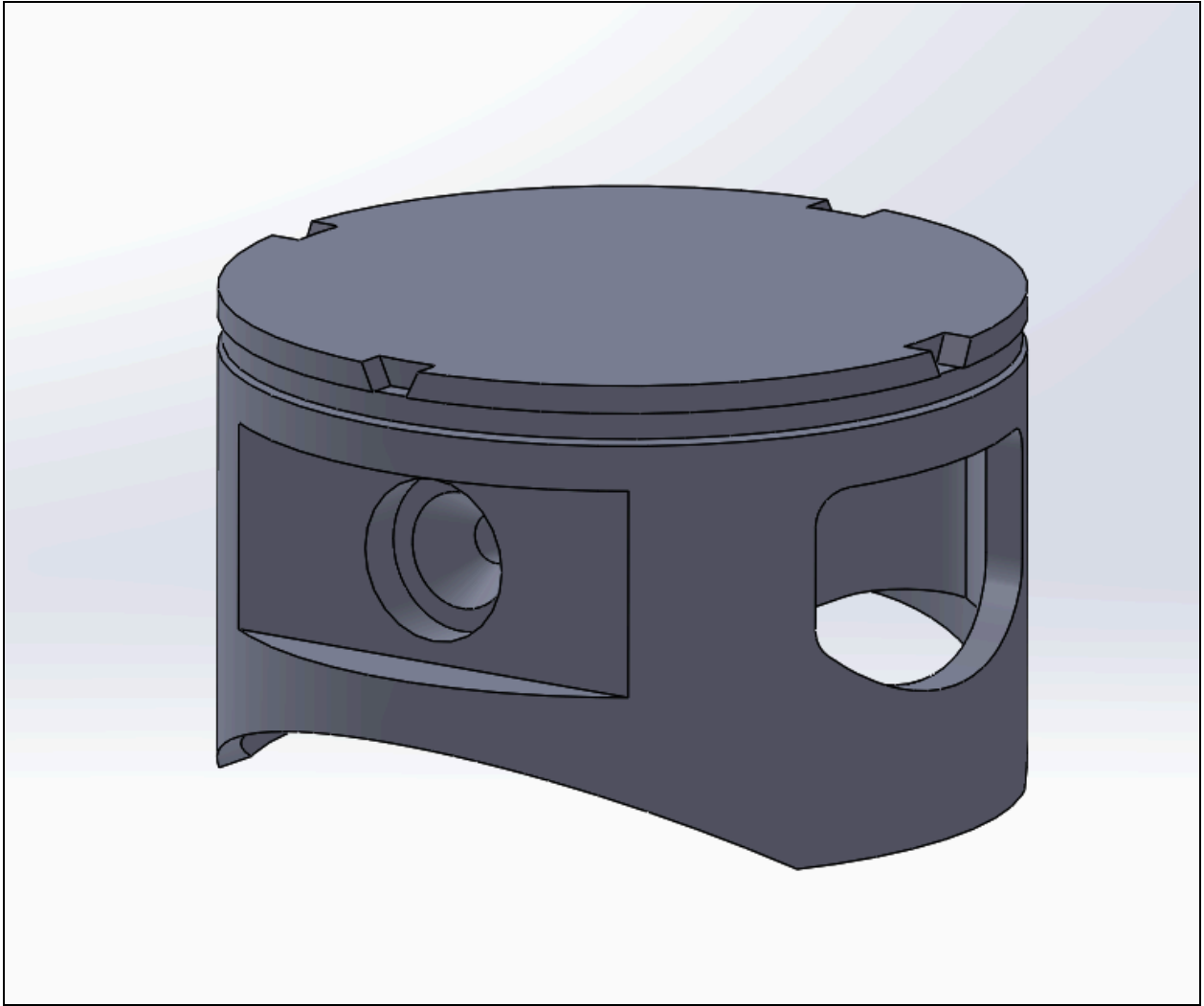

Piston Head with Ring and Wrist Pin

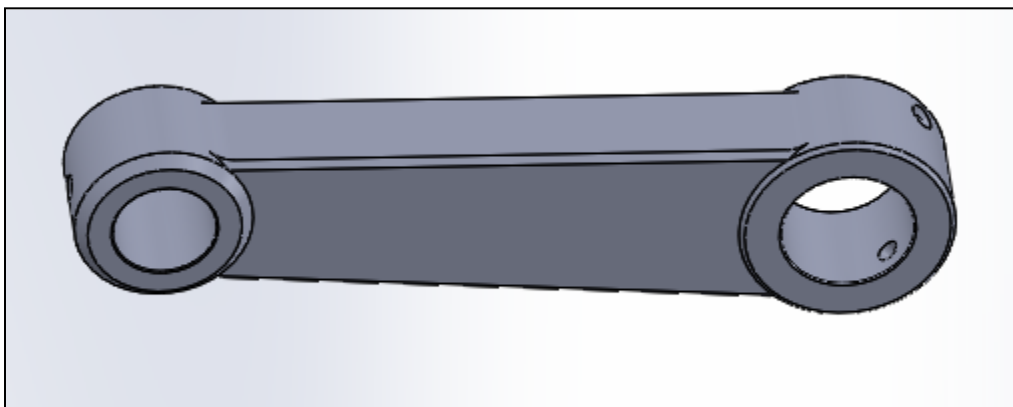

Piston Connecting Rod

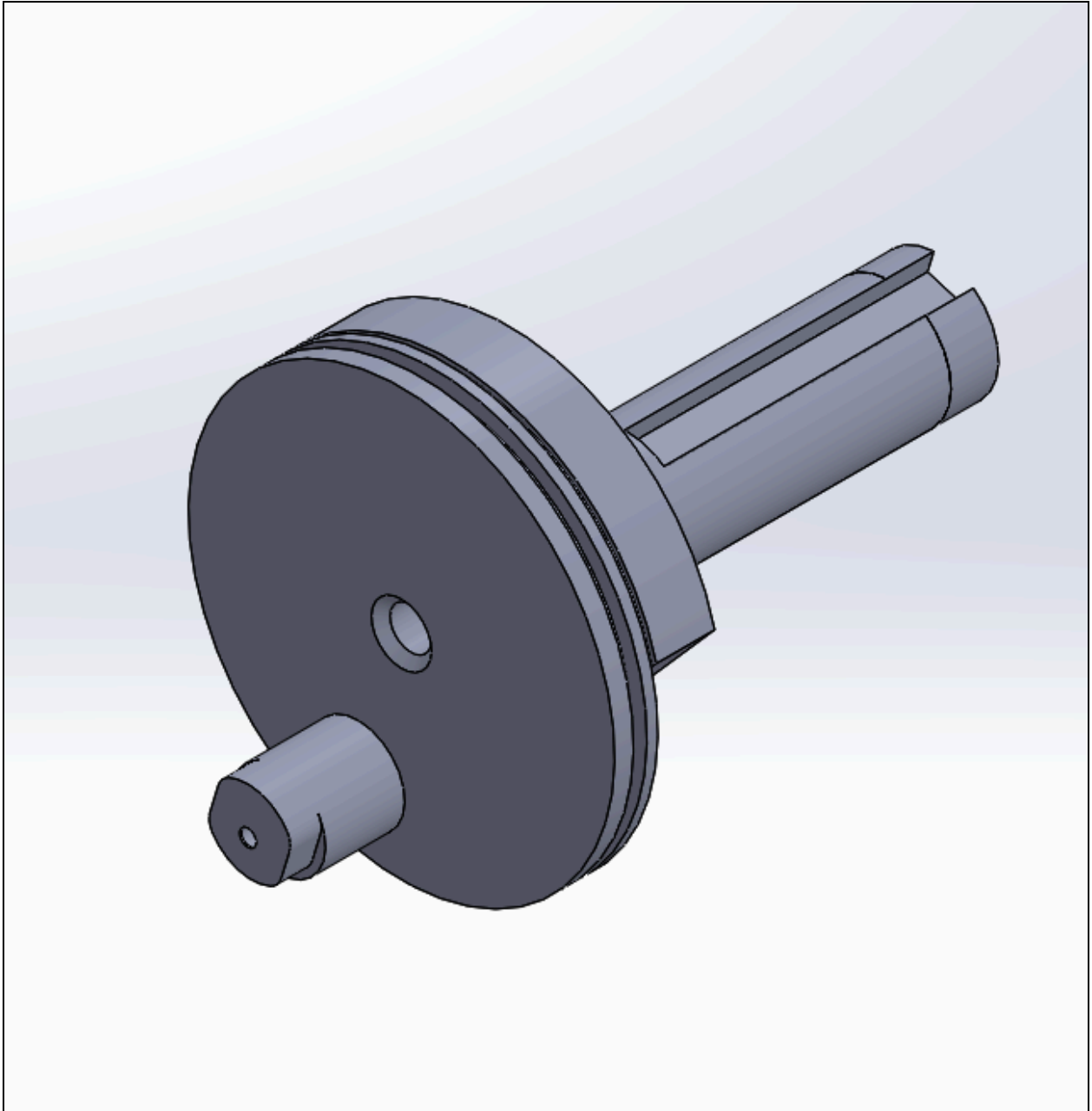

Crankshaft