

WORCESTER POLYTECHNIC INSTITUTE

# Redesign of a Medical Courier Robot

---

Analysis and Improvement on a robot drivetrain

**Advised By: Professor Eben Cobb and Professor John Sullivan**

**Dan Foley, Jonathan Gaffen, John Petitpas**

**4/25/2012**

## Abstract

Delivering supplies quickly and efficiently in hospitals is a problem that can mean the difference in proper medical care. If certain kits are not restocked in a department the efficiency and quality of the medical care will suffer. Couriers deliver these supplies however, human error, breaks, and distractions create a process which can be streamlined. To cut down on delivery times, redundant deliveries of supplies, and create a streamlined process in hospitals, medical robots such as the TUG® were implemented to help solve these problems by removing a human courier. However, in certain cases the TUG® will come to an impasse in a corridor that it can't get itself out of, halting deliveries. In some instances this causes other TUG®s to become stuck as well, compounding the problem.

The primary goal of this project was to analyze the TUG® and similar robotic courier both in operation and design and create a drivetrain for a robot that is more robust and maneuverable to help alleviate problems in daily operation, allowing robots such as the TUG® to complete the functions they were originally designed to accomplish. Existing drivetrain systems were researched and analyzed through decision and design matrices to choose a drivetrain which could most benefit this application. A mecanum drive was chosen due to several factors including mobility, reliability, and maintenance among others.

Testing was conducted to evaluate how the robot compared to existing applications. Static and dynamic stability, physical characteristics, and safety were all tested. Recommendations are made for future development of the robotic system to better performance and possibly spawn future projects.

## Acknowledgements

This project group would like to thank Professor Eben Cobb and Professor John Sullivan for their guidance and insights through the course of the entire project. We would also like to thank Barbara Furhman with the assistance of ordering everything we needed to create this project. We would also like to thank Alessandro Aquadro (ME) and Andrew Bennett (ME) for their help machining. Their help with the machining and welding of our project was an intricate part to our success. We would also like to thank Ross Desmond (RBE), Jake Dusek (RBE), and Chris Berthelette (RBE) with their help assisting us with the programming and the calculation of the inverse kinematics of the robot chassis.

## Table of Contents

Abstract.....	1
Acknowledgements.....	2
TABLE OF FIGURES .....	6
TABLE OF TABLES .....	8
CHAPTER I: INTRODUCTION.....	9
Use of Autonomous Robots in Hospitals .....	9
CHAPTER II: BACKGROUND.....	12
Types of Medical Courier Robots.....	12
TUG® by Aethon.....	12
RoboCourier .....	17
West Roxbury VA – Onsite Visit .....	17
Drivetrain Types.....	20
Mecanum Drive.....	20
Swerve Drive .....	22
Ackerman Drive.....	22
Killough Drive .....	23
Skid Steer/ Differential Drive .....	24
Omniwheels .....	24
Decision Matrix.....	25
Design Matrix.....	26
CHAPTER III: Design Selection.....	27
Mecanum Drive.....	27
Tipping Angle for New Design.....	29
Force Required To Tip .....	30
Tipping Due to Acceleration.....	31
Ground Clearance .....	31
Wheel Pod Design .....	34
Suspension .....	36
FEA on Chassis and Wheel Pods .....	37
CHAPTER IV: Manufacturing .....	37

---

Manufacturing Planning.....	37
Machined Parts .....	39
Chassis.....	39
Wheel Pods .....	39
List of Purchased Parts.....	40
Final Assembly Process .....	41
Electrical Wiring .....	42
CHAPTER V: Programming the Robot .....	43
Programming Necessity .....	43
VI Construction .....	43
C Programming in Arduino.....	47
Testing Procedures .....	50
Task Specifications .....	52
Testing Protocols.....	54
CHAPTER VI: Testing Results .....	57
CHAPTER VII: Discussion .....	61
CHAPTER VIII: Recommendations.....	62
CHAPTER IX: Conclusions .....	64
BIBLIOGRAPHY .....	65
APPENDIX .....	66
Appendix A: FBDs.....	66
Appendix B: Project Timeline Gant Chart .....	67
Appendix C: Cost Tables.....	68
Appendix D: Attheon TUG® Robot .....	72
Appendix E: Robot Chassis.....	73
Appendix F: ADA Ramp Standards.....	76
Appendix G: Velocity of a Point for Mecanum Drive .....	79
Appendix H: Final CAD Model.....	80
Appendix I: Final CAD Model - Mass Properties .....	81
Appendix J: Final CAD Model FEA – Model Information.....	82
Material Properties .....	82
Loads and Fixtures .....	82

---

Resultant Forces.....	83
Appendix K: Final CAD Model FEA .....	84
Appendix L: Wheel Pod FEA – Model Information .....	86
Material Properties .....	86
Loads and Fixtures .....	87
Resultant Forces.....	87
Appendix M: Wheel Pod FEA Results.....	88
Appendix N: Arduino Code .....	90
Appendix O: Demonstration Videos .....	93

## TABLE OF FIGURES

Figure 1 - Cut Open View of the Front Section of the TUG.....	13
Figure 2 - Full TUG with Cabinet System.....	14
Figure 3 - TUG Sensor Array.....	15
Figure 4 - TUG Charging Station.....	16
Figure 5 - RoboCourier .....	17
Figure 6 – TUG® charging stations .....	18
Figure 7 – TUG® center pivot .....	18
Figure 8 - TUG waiting for attendant .....	19
Figure 9 - Mecanum Drive.....	20
Figure 10 – Mecanum Configuration .....	20
Figure 11 - Mecanum Drive Forward Direction .....	21
Figure 12 - Mecanum Drive Net Forces .....	21
Figure 13 - Swerve Drive .....	22
Figure 14 - Swerve Drive Configuration .....	22
Figure 15 - Ackerman Steering.....	22
Figure 16 - Ackerman Center of Turning.....	23
Figure 17 - Killough Drive .....	23
Figure 18 - Skid Steering .....	24
Figure 19 - Omni Wheel Drive.....	24
Figure 20: Chassis Design .....	27
Figure 21: Side View of Chassis.....	32
Figure 22: Wheel Pod.....	36
Figure 23: Chassis Frame Solid Works Model .....	38
Figure 24 - Electrical Wiring Diagram.....	42
Figure 25 - Labview Input Panel.....	44
Figure 26 - Sample of Labview Equations .....	44
Figure 27 - Initial Wheel Output Values.....	44
Figure 28 - Scaling Function within Labview .....	45
Figure 29 - Extraction from Array .....	46
Figure 30 – Final Vi Program .....	47
Figure 31: Attach Code.....	48
Figure 32: Forward Command .....	48
Figure 33: Right Hand Turn .....	49
Figure 34: Translate Left .....	49
Figure 35: Example Working Code.....	50
Figure 36 - FBD of Robot .....	66
Figure 37 - FBD of Acceleration.....	66
Figure 38 - TUG Robot.....	72
Figure 39 - TUG Inside Details.....	72

---

Figure 40 – Skid Steer (two wheels + motors with casters).....	73
Figure 41 – Skid Steer (four motors + wheels).....	73
Figure 42 – <i>FIRST</i> Robotic Swerve Drive .....	73
Figure 43 - Swerve Drive Detail.....	74
Figure 44 – Mecanum Wheel Pod.....	74
Figure 45 - Single omniwheel.....	74
Figure 46 - Double omniwheel.....	75
Figure 47 - Accessible Route Changes in level .....	76
Figure 48 - Carpet Pile Thickness .....	77
Figure 49- Components of a Single Ramp Run.....	78
Figure 50 - Velocity of a Point for Mecanum .....	79
Figure 51 – Final Chassis Isometric View .....	80
Figure 52 – Final chassis design .....	80
Figure 53 – Mass properties of chassis unloaded.....	81
Figure 54 – Displacement on Chassis.....	84
Figure 55 – Displacement on Chassis.....	84
Figure 56 – Stress on Chassis .....	85
Figure 57 – Stress of Wheel Pod .....	88
Figure 58 – Displacement of Wheel Pod.....	88
Figure 59 – Strain on Wheel Pod .....	89



## TABLE OF TABLES

Table 1 – Decision Matrix.....	25
Table 2 - Design Matrix .....	26
Table 3 – Purchased Parts for Manufacturing .....	40
Table 4 – Purchased Parts for Assembly .....	40
Table 3 - Project Gant Chart.....	67
Table 4 - Motor Cost .....	68
Table 5 - Potential Batteries.....	68
Table 6 - Electrical Components .....	69
Table 7 - Wheel Cost .....	70

## CHAPTER I: INTRODUCTION

### Use of Autonomous Robots in Hospitals

Within the hospitals there are hundreds of tests and samples taken every day and these materials need to be brought from the location of the tests to the proper lab for analysis and examination. In addition, medicine and food need to be delivered to patients in a timely manner to reduce wait times and keep visits as short as possible. Normally all of these deliveries need to be done by one or more human couriers. This employee or employees, due to human nature, can become distracted or tired, will require breaks which delay the deliveries, and can make mistakes as to where deliveries need to go, leading to complications. These human couriers also require working in shifts, i.e. one full time courier will only work 40 hours each week. This makes it so that information and goods needs to be transferred between couriers during shift changes decreasing efficiency and increasing the possibility for errors. To counter these problems the same delivery tasks could be given to a robot which could make the deliveries without breaks and without errors. The goal of Aethon's TUGS and similar courier robots are to reduce the mistakes made and time taken during deliveries, as well as to free up time for existing employees to focus on the more complex areas of their work. At St. Margaret Hospital, three TUGS were introduced to monitor the cut wait times and improved efficiency of deliveries. In one day the TUGS made as many as 86 trips with vital supplies, however to obtain more data the TUGS were monitored for several weeks. After several weeks it was calculated that the three TUGS saved St. Margaret Hospital approximately 60 man hours per week which is equivalent to the hours of 1.5 full time employees. In addition to saving time, the TUGS were estimated to be greater than 20% more accurate with deliveries, reducing extra trips needed to correct mistakes.

Another important aspect of the TUG's service is the cost associated with not only installing but maintaining the robots compared to the cost of paying human employees. In a Virginia Hospital, six TUGS were installed for \$600,000 with an annual upkeep of \$150,000. However, after a year of full

service the six TUGS had saved the hospital almost \$450,000. An annual return on investment of nearly 50%, and at that rate the TUGS were able to pay for themselves within a span of only two years.

According to Aethon's own numbers, one TUG running constantly at full capacity can save a hospital time equal to as much as 2.8 full time employees. While this is less than what was seen in St. Margaret, Aethon's numbers assume the robot is never resting unless it is charging and is in operation 24 hours a day. However, even if they cannot run at full efficiency, the cost of a single TUG is less than one full time employee so the savings can still quickly add up. These savings are especially important when 33% of hospitals nationally are operating at a deficit. Courier robots such as the TUG will allow hospitals to cut their deficits while improving care quality and efficiency. Going into the future, Aethon are focused on significantly reducing cost of the TUGS to help reduce the \$600,000 upfront payment needed from hospitals to install the system. By reducing this price they can become more widely available to more hospitals that run on smaller budgets.

Although, the TUG and courier robots similar to it have been shown to improve the delivery accuracy and time in a hospital setting these robots do not come without drawbacks. Courier robots currently are either maneuverable or able to have a large capacity, which does not meet all of a hospital's needs. Aethon's TUG system is able to carry up to 500 pounds and has a large cabinet for storage, at the expense of very poor maneuverability. The TUG operates with a small front portion of the robot which pulls around the rest of the chassis holding the cabinet. This is a problem because it leaves the TUG with a very large turning radius. The TUG requires nearly the entire floor space of an elevator to turn itself around to exit. It is able to make U-turns in the hallway however, it cannot make the turn if there is anything else in the hallway. Although these issues may come up every once in a while the TUG often reaches obstacles which it is not able to pass in the hallway. The busy nature of a hospital hallway with carts, wheelchairs, and foot traffic present a traveling scenario which requires a

fair bit of maneuverability. If the TUG is stuck behind a cart in the hallway which it cannot seem to navigate itself out of it is no longer being the super productive machine it was designed to be.

Other courier systems such as the RoboCourier are designed to have a very small turning radius, however they lack storage. The Robocourier is designed to be very circular with two driven wheels and free casters which allow it to have a zero turning radius. However, the RoboCourier can only carry one tray on top of the robot at a time. So whatever you can place on a standard lunch tray will be delivered appropriately in the hospital. This system would be fine for small deliveries, but is very poor for large deliveries or for sensitive material. The TUG is able to take several trays of food from where it is prepared to the individual rooms where it needs to go. Also the TUG is able to lock away sensitive information such as test samples or medical records in its cabinet, where leaving it in a basket or on a tray atop the RoboCourier would not protect patient privacy. Due to these factor and others the existing systems cannot merely be merged but a new drivetrain system must be designed to have the ability to carry a large amount of weight and be fitted with a cabinet as well as have the maneuverability to navigate a busy hospital environment reliably without requiring assistance.

---

## CHAPTER II: BACKGROUND

### Types of Medical Courier Robots

#### TUG® by Aethon

The TUG® was designed to make deliveries within and between departments in hospitals. Aethon currently has four patents relating the TUG® system. The first patent which was filed is patent number US 7894939 B2 and dates to February 22, 2011 and the newest patent is patent number US 8204624 B2 which dates June 19, 2012. This is a new technology which was meant to replace any human workers which would need to transport items around a building or more specifically a hospital. The TUG® works twenty-four hours a day, seven days a week making both scheduled and on-demand deliveries.

The TUG® uses sealed, lead acid, rechargeable batteries to power twin independent twenty-four volt DC drive motors and accompanying electronics for six hours on a full charge. These motors power two drive wheels in the front portion of the TUG® and each wheel is driven independently so that position sensing can be done on a per wheel basis. These are four inch rubber coated wheels commonly found in applications such as wheel chairs. The other two wheels are fixed casters and are led by the front section which does all of the sensing, computing, and navigating for the TUG®.

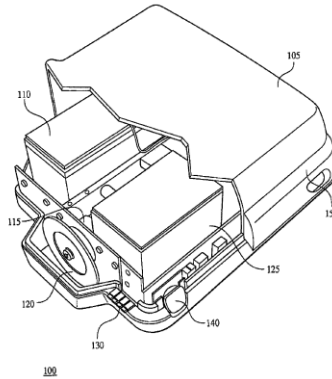

**Figure 1 - Cut Open View of the Front Section of the TUG**

The TUG<sup>®</sup> is designed so that at normal loads it will be able to operate at a speed up to three feet per second. The Items delivered by the TUG<sup>®</sup> are either locked in a cabinet on the back, for sensitive deliveries, or placed on the back of the TUG<sup>®</sup>, for deliveries such as food trays. The standard dimensions of the cabinet are approximately 22.8" wide x 24.9" deep x 40" high. These locking cabinets are outfitted with an electronic locking mechanism and a keypad lock. These locks are programmed with one or more passwords given out to certain personnel in order to restrict access and track which authorized user opened the cabinet at what time. Such a high level of security is important when the carried items would include blood samples, confidential patient records, and required drugs.

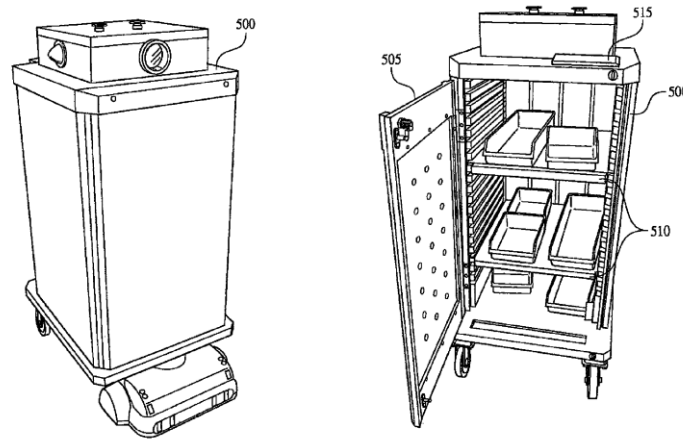

Figure 2 - Full TUG with Cabinet System

This robot senses its environment by using infrared sensors or “light whiskers” which allow it to “see” the hallway it is in and recognize obstacles and/or landmarks that are in the corridor and so the TUG<sup>®</sup> can avoid them. The front portion of the TUG<sup>®</sup> is outfitted with several pairs of these infrared sensors. One pair of sensors looks almost directly upwards in order for the TUG<sup>®</sup> to sense any objects which may protrude from the wall or are too high off the floor for the other sensors to pick up. Another pair of sensors is directed at nearly a ninety degree angle from the front of the TUG<sup>®</sup>. These sensors constantly sense the distance between the TUG<sup>®</sup> and the wall and are primarily responsible for gathering the data used by the TUG<sup>®</sup> operating system to correctly orient the TUG<sup>®</sup> on its path.

The TUG<sup>®</sup> also has an array of other infrared sensors facing forward at various angles in comparison with the floor. This array is primarily responsible for obstacle detection and avoidance. This array can be broken into several pairs of sensors with each sensor intersecting with its pair. The sensors

intersect is to avoid missing anything which may be too thin and could slip between forward facing sensors.

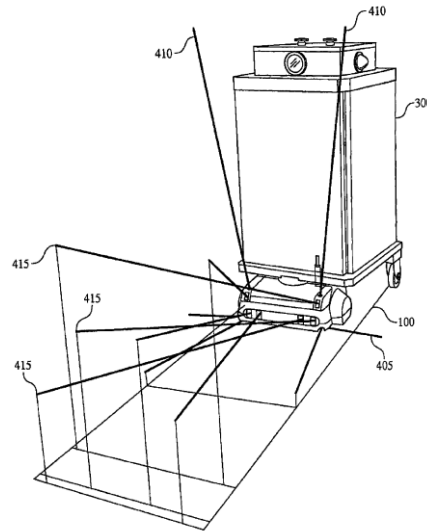

Figure 3 - TUG Sensor Array

As part of the installation of the TUG® system Aethon visits the hospital to create a detailed map of the hospital floors. The TUG® is preprogrammed with a digital CAD map of the hospital floor plan to allow it to know where it is, and where it needs to go. Such a floor plan could be accomplished with two-dimensional CAD software such as Auto Cad. Landmarks such as the locations of doors, automatic doors, elevators, and charging and docking stations are overlaid onto the floor plan. Finally, the intended paths which the TUG® is supposed to follow from point to point are programmed in. These paths along with the CAD map and the sensor input work together to tell the TUG® its position in real life. Because of this method of programming fewer check points are needed since the route has been pre-assigned.

Between trips the TUG® returns to a docking station in order to charge and run diagnostics. The TUG® pulls up to a plate on the floor which is connected to a normal 110 volt wall outlet to provide power to recharge the batteries. A full recharge of the TUG®'s batteries would take four hours to achieve, however the TUG® is programmed to return back to the charging station between trips to



charge for five minutes to ensure that there is enough power for the next trip to be completed properly. This docking station also includes a display in order to be able to check any errors or gather any data from the TUG<sup>®</sup> as well as to select a new trip for it to make.

Finally, the TUG<sup>®</sup> is capable of calling elevators and opening automatic doors through a wireless Ethernet connection. As the TUG<sup>®</sup> navigates it uses its preprogrammed map to identify where the doors and elevators it can communicate with are located. Once it arrives at one of these doors it stops and will transmit a wireless signal which will unlock the door and cause it to open or to call the elevator.

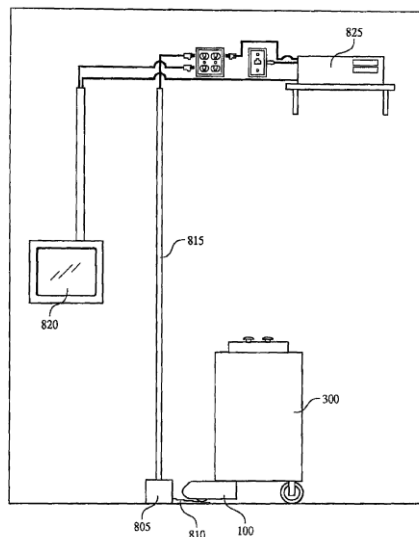

Figure 4 - TUG Charging Station

In order to successfully make deliveries, the TUG<sup>®</sup> will navigate through the hospital based on the onboard map it has stored in memory and following the preprogrammed route. While on the charging station the TUG<sup>®</sup> receives its list of deliveries to make and the order in which to make them. It will recognize each location and then try to follow its preprogrammed route as much as possible however if it discovers unexpected obstacles in its desired path the TUG<sup>®</sup> is capable of adjusting its path to accommodate these obstacles. Between deliveries the TUG<sup>®</sup> briefly docks for five minutes to ensure

it has enough power and to see if there has been a change made to its delivery schedule. The TUG® navigates through the hospital and communicates with the hospital elevators and doors through wireless Ethernet connections which allow it to call an elevator and tell the elevator which floor it wants to go to or unlock and open a door.

### RoboCourier

Similar to the TUG which is used in hospitals in America, there is an autonomous robot in use in Europe developed by SwissLog called the RoboCourier. It has some of the maneuverability that we are looking to achieve on a much smaller scale. The robot's footprint is nearly circular which allows it to safely rotate with a zero turn radius. It operates using 2 powered wheels with 4 free casters on the approximate corners of the robot. By driving the two powered wheels in the same or opposite directions the RoboCourier can drive forwards or rotate in place. The robot utilizes sensors around the entirety of its chassis in order to view 360 degrees around itself in order to judge when and where it can safely move. It contains similar software and wireless capabilities to the TUG which allows it to operate elevators and automatic doors. However the RoboCourier can only carry a maximum load of 55 pounds



Figure 5 - RoboCourier

as compared to the TUGS maximum load of 500 pounds. Also, as the TUG is rectangular in shape, a zero turn radius would cause issues with the back end swinging into objects near the sides of the TUG. Thus the RoboCourier system cannot simply be merged with the TUG system in an attempt to gain the best of both platforms. Instead an entirely new drive train and chassis would have to be designed in order to allow for the best features of both systems.

### West Roxybury VA – Onsite Visit

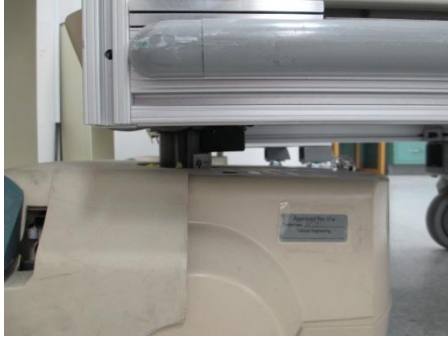

Figure 7 – TUG® center pivot

On Friday  
September 21<sup>st</sup> and  
again on November  
5<sup>th</sup>, we visited the



Figure 6 – TUG® charging stations

West Roxbury VA hospital to get a better view of the TUG® robots within the environment we are focusing on for this project. We started by visiting the blood lab which has 2 docking stations for TUGS to recharge between trips from the pharmacy or other labs working with the blood technicians. Both charging stations were in use as shown in Figure 6 – TUG® charging stations. Multiple pictures were taken of the TUGS charging at the stations as well as some of the features of the TUGS such as the center pivot used to rotate the drive system Figure 7 – TUG® center pivot and the emergency switches located near the front of the robot. In addition to taking pictures we were able to briefly speak with one lab technician about their experience with the robots. Even though they indicated they don't interact with the TUGS as often as the pharmacists who deploy them do, they did say one major problem they had to send technicians to fetch the robots when they became stuck. The technician also informed us that in the week prior to our visit the TUG strayed from its normal path and reversed to turn around instead of pulling forward. In doing so it backed into an unseen object causing the TUG to tilt past its tipping point and was only saved from falling over by a nearby worker who caught and righted the robot. This can be attributed to lack of a complete sensor array as opposed to the front facing only sensors used in the current version of the TUG. Other information gained from the interviews included the TUGS bumping into doors because they either failed to signal it to open or the door would close too quickly. Finally, they commented on the lack of any useful interface that could display information. This

would be helpful to the staff in determining whether a TUG is stuck or just waiting and processing information before proceeding.

Other pictures were taken of the solid body TUG while it was parked at a nurse station waiting to be unloaded. Unlike the version found in the blood lab, the solid body version lacked free rear casters and instead had 2 rear fixed casters. There was also an additional sensor array located in the front center panel of the robot, giving a taller field of view for the TUG to operate within, but still no side or rear sensors were in place. Both TUGs have a



Figure 8 - TUG waiting for attendant

keypad used to secure the deliveries. According to the staff, this lock runs on a separate battery and when the battery dies all access to the specimens and other material is prevented until a replacement battery is installed causing potential issues with time sensitive tests.

## Drivetrain Types

The different drivetrains being considered for the project are skid steer, Killough drive, mecanum, Swerve Drive, Ackerman, and the TUG<sup>®</sup> system. Drivetrains close to skid steer by variation of wheels variations being looked into are wheels with omniwheels and wheels with casters. These different types of drivetrains and variations present us with many options to research into to best solve the maneuverability problem. Through research into each drivetrain we will then be able to weigh the pros and cons of each system against each other in a design matrix that will assist in limiting down the many options.

### Mecanum Drive

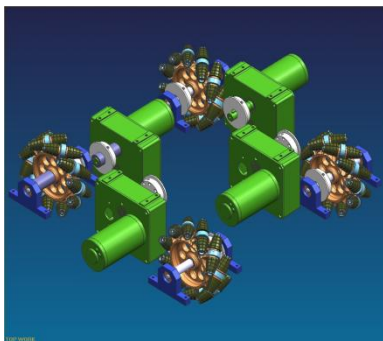

Figure 9 - Mecanum Drive

Mecanum drive systems are similar to omniwheels in that they are comprised of a central hub with multiple rollers spaced about the hub. The main difference for mecanum wheels is that the rollers are positioned at a 45°. The robot moves in different directions when different amounts of power are applied to specific motors. This application allows for the driving force of the wheel to be at a 45° angle instead of fixed to one of its axes (McInerney).

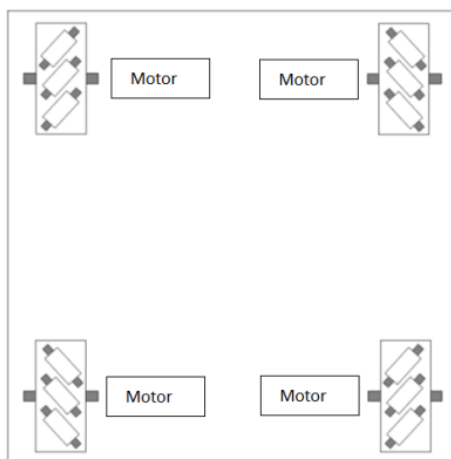
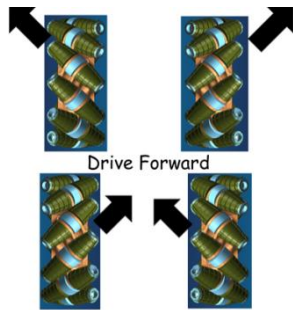

Figure 10 – Mecanum Configuration



For example, when applying power to the front two wheels in a clockwise motion, and counterclockwise motion to the rear two wheels, the robot will move forward. This allows the mecanum drive system to be very maneuverable and able to go in any direction when the motors powering the

wheel pods are given a certain amount of power. This design also allows for the robot to have the front

Figure 11 - Mecanum Drive Forward Direction

facing the direction it is moving at any given time (McInerney).

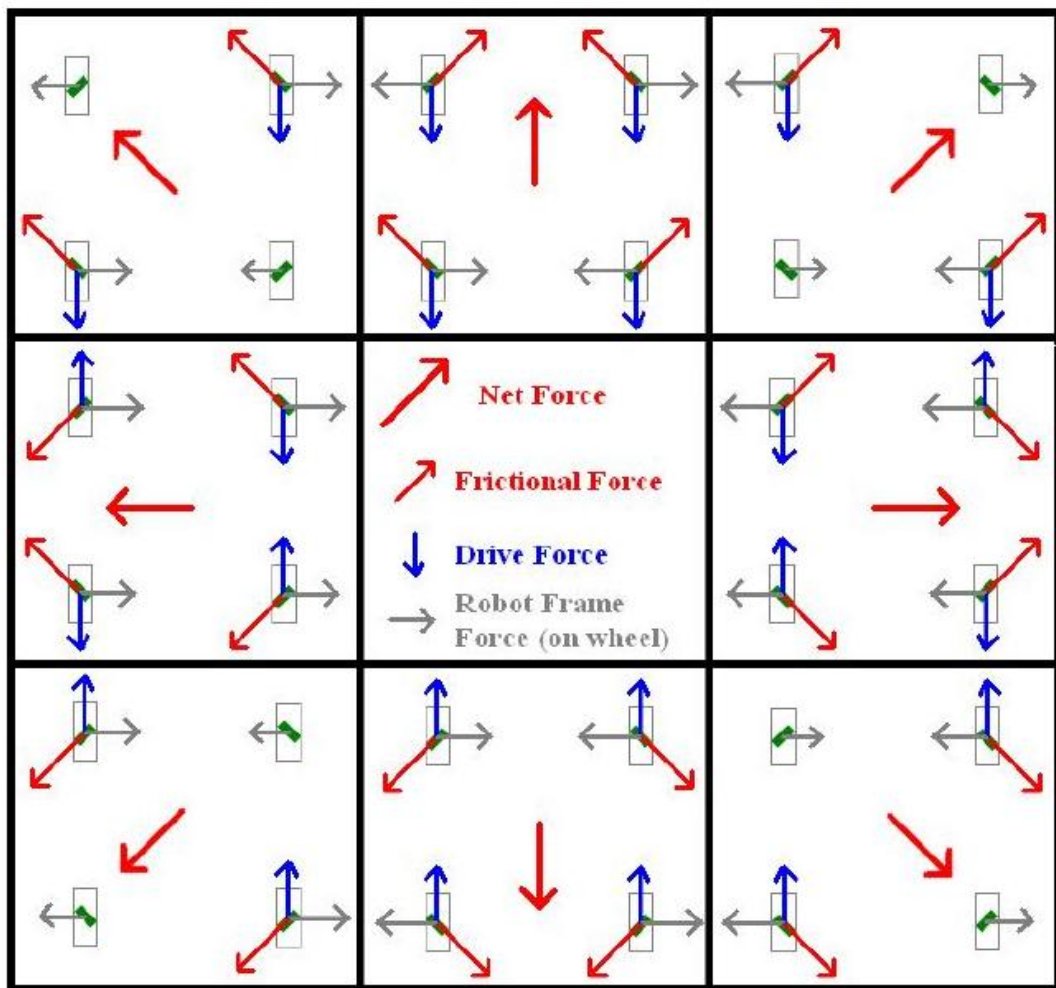

Figure 12 - Mecanum Drive Net Forces

## Swerve Drive

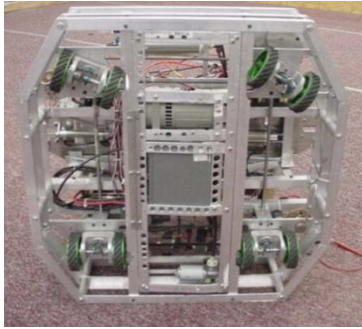

Figure 13 - Swerve Drive

A swerve drive is an advanced drive train where the robot is afforded 360° of motion. Swerve drive has the ability to mimic the functions of all other drive trains which gives swerve the ultimate mobility. One pitfall of Swerve Drive is the level of complexity required for the drive system to function. A Swerve Drivetrain is comprised of at minimum five motors, although eight is recommended. In addition to many motors, swerve requires multiple linkages such as chain and sprockets or gearing to accommodate the turning capabilities of Swerve.

On a function basis, Swerve Drive orients the robot's wheels in the direction it wants to travel and then goes in that direction and as stated before, this could be in any numerous directions due to Swerve Drives maneuverability. Each wheel is mounted onto an individual module that rotates independent of the chassis. This allows for the wheels to be to turn in any direction without spinning or changing the robots orientation.

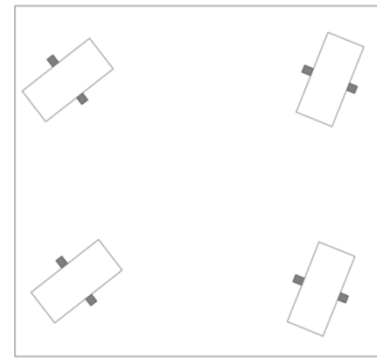

Figure 14 - Swerve Drive Configuration

## Ackerman Drive

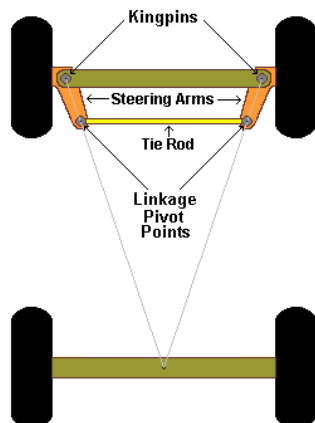

Figure 15 - Ackerman Steering

Ackerman steering also referred to as car steer, is another drivetrain option. Ackerman is dependent on the front wheels to steer as the rear wheels are for driving. If the front wheels in an Ackerman setup slip, then the robot's steering ability is negated. Ackerman Steering allows for the robot to turn in a fashion similar to that of a car. The front linkages are rotated by a servo motor to allow for the front wheels to point at the

specified angles. The downside of this design is that to turn around the robot needs to perform a U-turn or a multipoint turn. This can run into a large amount of room depending on the size of the robot.

Ackerman Steering is preferred for slight turning and mostly forward driving.

To find the turning radius of a robot using Ackerman steering depends on a variety of variables. First off, the length of the robot will come into account as a longer robot will require more space to turn around than that of a shorter robot with the same steering angle. The following equation is a close approximation of the turning radius of a robot utilizing Ackerman steering.

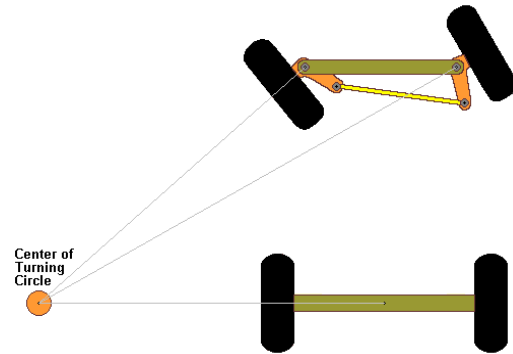

Figure 16 - Ackerman Center of Turning

$$\text{Turning Radius} = \frac{\text{Track}}{\frac{2 + \text{wheelbase}}{\sin(\text{steering angle})}}$$

Where track is the distance (center to center) between the left and right wheels, wheelbase is the distance (also center to center) between the front and rear wheels, and steering angle is the maximum angle that the steerable wheels may be turned.

### Killough Drive

Killough Drive is based on Stephen Killough's work with omnidirectional platforms in 1994. Killough's design used a pair of wheels mounted in cages at right angles which allows for the robotic platform to achieve

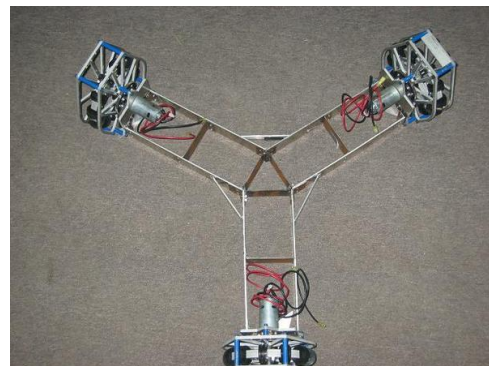

Figure 17 - Killough Drive



holonomic movement The concept behind Killough Drive that the three omniwheels and the triangular shape allow for a small footprint and can allow the robot to maneuver into spaces that a larger robot might not otherwise fit into.

### Skid Steer/ Differential Drive

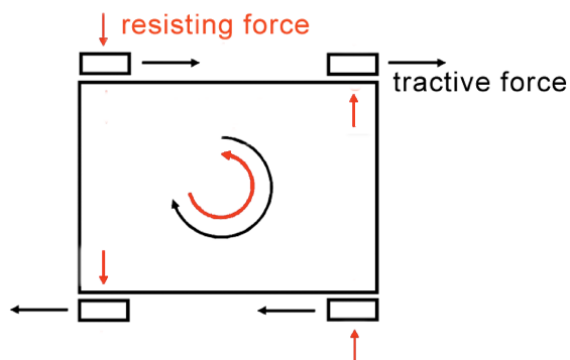

Figure 18 - Skid Steering

Skid Steer also referred to as Differential Drive is the simplest drive train configuration due to its basic requirements. Possible configurations are two fixed wheels with casters and two motors, four wheels with two motors, four wheels with four motors, six wheels with four motors, and so on. Skid Steer works by

applying power in the same direction to both sides to move forward, and in opposite directions to change direction. Reducing the distance between the two sides of the robot allows for a reduction in skidding.

### Omniwheels

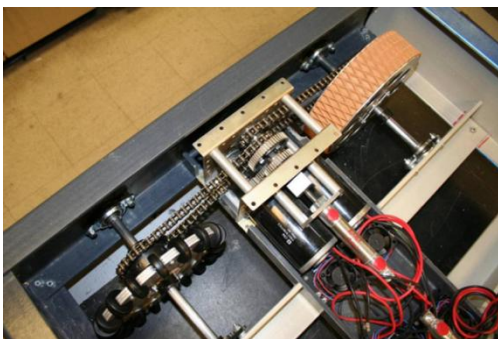

Figure 19 - Omni Wheel Drive

Omniwheels are designed with a number of passive rollers mounted on the outside of a regular wheel. The omniwheel is driven in the same fashion as a normal wheel but the rollers allow for free motion when turning. Omniwheels have problems with large loads due to the point of contact of the wheels and the floor. This can be

mitigated by using a double or triple omniwheel as seen in the Appendix.

## Decision Matrix

In following with the procedure outlined in Professor Norton's *Design of Machinery* design process, the following decision matrix was created to determine the components most important to the design a medical robot drivetrain. In Table 1 – Decision Matrix as seen below, maneuverability was determined to be the most important aspect of the project, as it is the biggest flaw with the current TUG system. The premise of the project is to design and build a robot platform that can navigate through crowded corridors better than the current TUG® design allows it to, thus making maneuverability the most important feature in the matrix. Following maneuverability is safety, stability, and then traction. These three features are the resulting most important aspects as the goal is to have this be brought into hospitals where safety and stability are of utmost importance. All of the selected attributes contribute directly to the overall design and effectiveness of the robot.

Table 1 – Decision Matrix

	Cost	Maneuverability	Safety	Speed	Stability	Battery Life	Complexity	Traction
Cost		1	1	0	1	0	0.5	1
Maneuverability	0		0	0	0	0	0	0
Safety	0	1		0	0.5	0	0	0
Speed	1	1	1		1	1	1	1
Stability	0	1	0.5	0		0	0	1
Battery Life	1	1	1	0	1		0.5	0.5
Complexity	0.5	1	1	0	1	0.5		0.5
Traction	0	1	1	0	0	0.5	0.5	
Total	2.5	7	5.5	0	4.5	2	2.5	4

## Design Matrix

Continuing to follow the design process mentioned above a design matrix as seen in **Error! Reference source not found.**, was created. This table takes into account the different types of potential drive trains researched to analyze which drive trains perform better in the areas we are most interested in. The different drive trains are listed in the first column, while the design features from the decision matrix are listed in the first row. This allows for the features to be directly linked to a specific potential design allowing for a more detailed decision process of which drive train should be chosen to be the design that is moved into the design phase. As seen in the table below, Swerve and Mecanum are the top choices for the final design due to their pronounced maneuverability. While they are the most maneuverable options they do present a level of complexity that may be unwanted in a medical robot application. TUGs® are able to run for up to 10 hours on battery power which forces them to be of a high robustness and lower complexity system to reduce the risk of failure at the hands of clients (CITATION TO BE ADDED). Although these tables help with the determination of the better drive trains the top choices must always be looked into further to determine which design is truly the best for the application at hand.

Table 2 - Design Matrix

	Maneuverability	Safety	Stability	Traction	1 / Complexity	1 / Cost	Rank						
Weight Factor	0.25	0.2	0.15	0.125	0.1	0.1	1						
swerve	8	2.0	8	1.6	10	1.5	7	0.875	2	0.2	2	0.2	6.375
Mecanum	9	2.25	6	1.2	8	1.2	5	0.625	4	0.4	4	0.4	6.075
Wheels	2	0.5	8	1.6	9	1.35	7	0.875	6	0.6	6	0.6	5.525
Killough	9	2.25	3	0.6	3	0.45	4	0.5	8	0.8	7	0.7	5.3
Tug	5	1.25	8	1.6	5	0.75	5	0.625	5	0.5	5	0.5	5.225
Ackerman	2	0.5	8	1.6	8	1.2	6	0.75	4	0.4	5	0.5	4.95
4 wheel w/ omni	4	1.0	6	1.2	6	0.9	4	0.5	6	0.6	6	0.6	4.8
Wheel w/ caster	1	0.25	6	1.2	7	1.05	5	0.625	7	0.7	8	0.8	4.625

## CHAPTER III: Design Selection

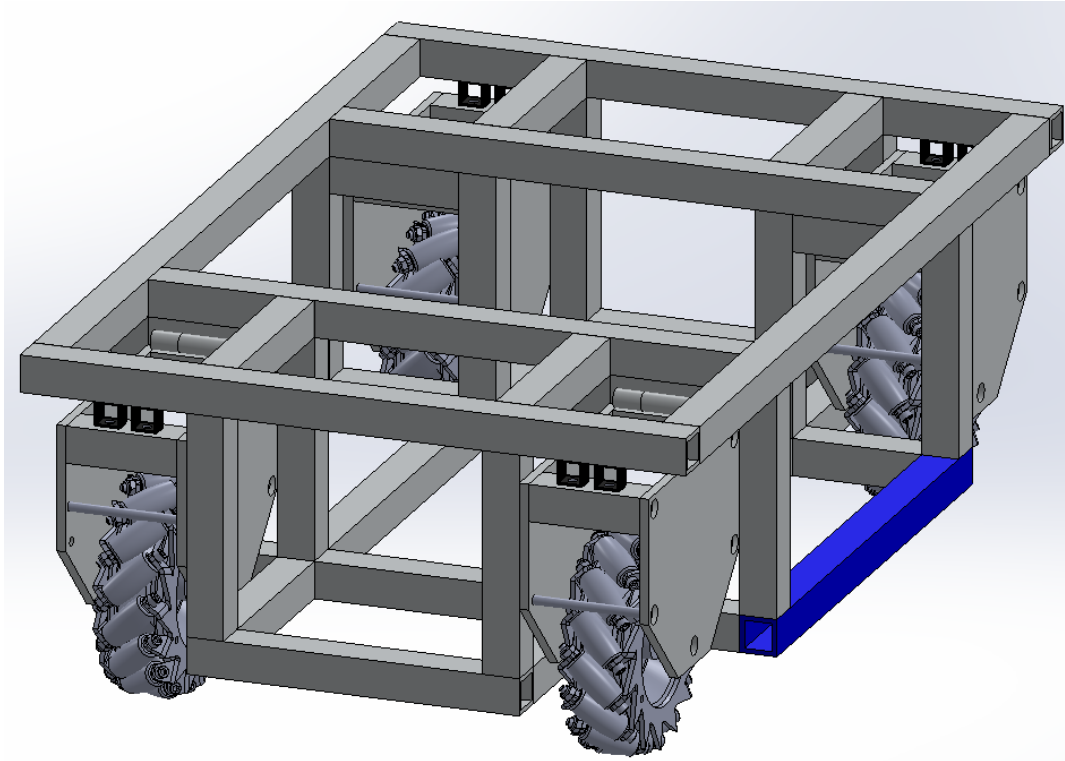

Figure 20: Chassis Design

### Mecanum Drive

The mecanum drive was chosen to be the best design for this application. Although the swerve drive was ranked above the mecanum drive, these were the top choices and were further assessed. A large portion of the goal of robotic couriers is to reduce cost and in order to do this complexity and reliability is important. The more complex a system is, the higher the manufacturing cost and therefore the upfront cost to the hospital will be. Also the more complex a system is the more difficult it will be to be repaired or replaced. If every time something goes wrong with the robot it needs to be shipped back to the manufacturer, it will become very costly for the hospital and it will lose the productivity of that robot for quite some time. Reliability becomes important because the more you need to repair a robot the more it will cost and the more production you will lose. The swerve drive does not do well in either

of these categories the need for 6 to 8 motors and some sort of gearing or linkage system makes the system both less reliable and more difficult to repair on site.

To combat both of these problems our design for the mecanum drive train introduces four separate wheel pods without any complicated gearing or linkages connecting them. Each wheel pod holds the suspension elements, the motor, and the wheel which can be taken in and out without requiring technical ability or background. This will allow for a minimal amount of components which can break down or deteriorate. Also if the hospital so chooses back up wheel pods can be in storage and quickly changed to keep the robot in use while the wheel pod is serviced, reducing down time and shipping costs.

The mecanum drive is a drive train which is at the forefront of maneuverability and is used in many fields such as military, industrial, and handicap mobilization. This drive train is mainly used in applications where there needs to be a fair amount of maneuvering around various obstacles in close quarters space. The ability to translate in any direction while also possessing a zero turning radius makes the mecanum drive excel in these situations.

The main drawbacks to a mecanum drive train include the requirement of four motors and indoor use only. The mecanum drive requires four motors in order to drive each wheel independently, although it requires no motors to rotate the wheels for steering. This will raise the overall cost of motors as compared to other designs; however it will also increase reliability. Since the mecanum drive operates nearly without mechanisms and linkages connecting the wheels there are more reliable components and in the event of motor failure the wheel pod could be easily replaced. The mecanum drive is mainly for indoor use because of how the wheels operate. In order to function properly the rollers on the wheels need to be able to rotate freely and if too much dirt or debris gets into the rollers to prohibit this motion, the system will not operate properly.

The mecanum drive has rollers on the outside of the wheels which are mounted at forty-five degrees which allow for steering without the rotation of wheels. These rollers allow the robot to determine its orientation based on the direction and speed in which it drives each individual wheel. An example of this as well as the equations can be seen in **Error! Reference source not found..** Not only does this system have a zero turning radius it can also translate in nearly every direction to have the true peak of mobility.

### Tipping Angle for New Design

Another area we are hoping to improve with our design over the current TUG model is that of the tipping point. In order to calculate the tipping point of the TUG some assumptions had to be made. We have no way to know how the TUG will be loaded and if it will be evenly loaded, so for a worst case scenario we assumed the maximum load of 500 pounds would be placed on the very top of the robot. To calculate the tipping angle first you need to determine where the center of gravity lies and for this we assumed the robot would be balanced directly over its center. In reality this is unlikely but without access to the specifics of the design we are unable to determine a more accurate model. The formula for Center of Gravity (CG) is  $CG = (W_1H_1 + W_2H_2 \dots) / (W_1 + W_2 \dots)$ . The robot for this is essentially three parts, the chassis, the cabinet and the load. The chassis is 50 lbs. and 10 inches high, the cabinet is another 50 lbs. and 39 inches tall and the load is 500 lbs. placed on top of the robot, 49 inches up. We used the height of the center of each section in the calculations and from the equation  $CG = (50 \cdot 5 + 50 \cdot 19.5 + 500 \cdot 49) / (50 + 50 + 500)$  calculated a final center of gravity 44.166 inches high.

To calculate the tipping point of our robot we formed a triangle with the center of gravity on one side, distance from the center of the robot to the outer line of the robot on the other and calculate the angle this triangle formed. Without changing the dimensions of the current robot, our new design was calculated to have a 12.75 degree tipping angle laterally from the equation  $\tan \theta = 10/44.166$ . For

the TUG, some adjustments needed to be made to determine distance to the outer line of the robot as the front wheels on the TUG are inset by 3 inches. Using the adjusted value for the wheelbase, we calculated the TUG to have an approximate tipping angle of 10.84 degrees. Our design would therefore provide a 17.65% improvement over the existing model. This can be further improved by widening the base of the robot and moving the weight of the chassis lower towards the ground.

The dynamic tipping angle is calculated as  $\Phi = \tan^{-1}(t / 2h)$  where  $t$  is the distance from the outer edge of one wheel to the outer edge of the opposite wheel and  $h$  is the center of gravity. The tread of our design is approximately 20 inches and the center of gravity is 44 inches above the ground. With these values, the dynamic role angle of our robot is 12 degrees.

## Force Required To Tip

As a precaution we wanted to calculate the force required to tip the robot should it be pushed along its top edge. First to ensure the robot wouldn't slide the force of friction along the ground needed to be calculated. The robot will not slide when pushed unless at least this much force is used, assuming the wheels are locked and not rolling. As 0.6 is the ADA recommended coefficient of friction for tile floors this is the value we used. **Friction:**  $600 \text{ lbs} * 0.6 = 360 \text{ lbs}$  of force due to friction. The force to tip was calculated from both the side and the front of the robot. In addition, we calculated it with the robot both fully loaded and lightly loaded.

**Side (Full):**  $(600 \text{ lbs} * 10") / 49" = 122 \text{ lbs}$       **Light:**  $(200 \text{ lbs} * 10") / 49" = 40 \text{ lbs}$

**Front (Full):**  $(600 \text{ lbs} * 12.5") / 49" = 150 \text{ lbs}$       **Light:**  $(200 \text{ lbs} * 12.5") / 49" = 50 \text{ lbs}$

As the most common point of contact should someone bump into the robot would be the area around the hips we chose to also calculate the force at that height as well. Statistics show that the

average height of the hips to be roughly 2.8 feet. Assuming a slightly taller individual with hips at 3 feet, the point of contact against the robot would be 36 inches above the floor. The required force to tip the robot at this height is as follows

$$\text{Full load: } (600 \text{ lbs} * 10") / 36" = 165 \text{ lbs} \quad \text{Light: } (200 \text{ lbs} * 10") / 36" = 55 \text{ lbs}$$

## Tipping Due to Acceleration

The final situation to consider for the robot is one where rapid acceleration causes the vehicle to rise off of its wheels in a wheelie motion. As the robot can move laterally we also need to consider the possibility of it tipping when sliding as well as driving forwards. The equation to determine acceleration required to tip is  $A=(D/2h + \theta)g$  where  $h$  is center of gravity height,  $D$  is tread width and  $\theta$  is the slope of the surface. When moving laterally to avoid an object the robot would be operating on a level surface so  $\theta$  drops from the equation. With a center of gravity of 44 and tread width of 20 The equation becomes

$$A=(20/88)g = 0.22g \text{ or } 1.82 \text{ mps}^2$$

When moving forwards, the worst case scenario would be accelerating from a stop while on one of the hospital ramps. As mentioned earlier. The ADA limit for ramps is approximately five degrees. The tread from front wheel to rear wheel is 25 inches so the equation for forwards acceleration required to tip is

$$A=(25/88 + 5/180*\pi)g = 0.37g \text{ or } 3.64 \text{ mps}^2$$

## Ground Clearance

Our design allows for one inch of ground clearance with a fully loaded system. This dimension was chosen so that the chassis would be as low to the ground as possible, lowering the center of gravity, without the chassis colliding with the ground. The obstacles which the robot would have to maneuver



over would include door sills, elevator entrances, and ramps as this is designed for the hospital setting where cleanliness is important.

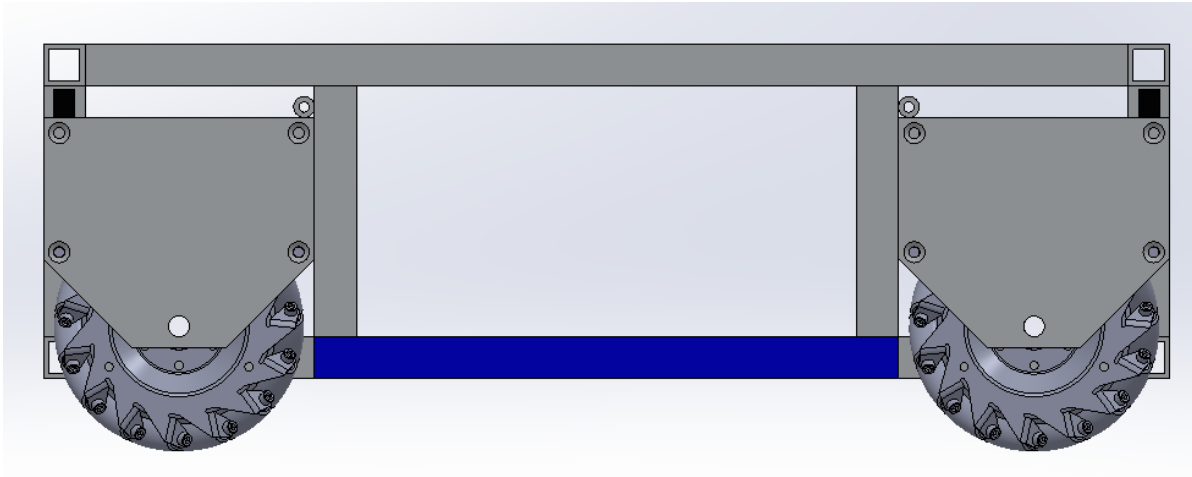

Figure 21: Side View of Chassis

The ADA has regulations for nearly all aspects of accessibility which must be strictly adhered to in a hospital. ADA regulations for a door's sill or threshold are a maximum height of  $\frac{3}{4}$  in or 19 mm for exterior sliding doors. The regulations for all other doors, the doors we will be dealing with, and not to exceed  $\frac{1}{2}$  in or 13 mm (access board). ADA regulations state that the elevator must operate automatically and must be equipped with a self-leveling feature which will automatically bring the car to floor landing within  $\frac{1}{2}$  in or 13mm under conditions including a between zero loading and the rated loading. This device is automatic and independent of the operating device and must correct the overtravel or undertravel. As stated in Appendix F the maximum slope of a ramp must be a 1-12 slope.

Our clearance of one inch allows the robot to clear all of these obstacles. It is clear without calculations that with the wheels on either side of the door threshold there will be no contact between the chassis and the threshold. However, since the centers of the wheels are the pivot points and they are not at the ends of the chassis enough of an incline may cause the chassis to collide with the floor. With one wheel on the threshold and one on the floor the chassis would be at the largest angle and

would have the highest possibility of scrapping the rear of the chassis. This design has the required clearance to get around this problem. The center of the wheel is 3 in above the floor, the rear is 4.5 in away from the center of the wheel, and the chassis sits 1 in above the floor. Since the chassis has no choice but to rotate about the center of the wheel the back end can be rotated until it would make contact with the floor and the angle can be measured. Having the back of the chassis collide with the floor requires an angle of about 15 degrees. The linear distance from wheel center to wheel center is 18 in meaning that there would be a distance of 22.5 inches between the back end of the chassis and the further wheel center. This creates a triangle with an angle of 15 degrees and a hypotenuse of 22.5 in.

$$\sin(15) = \frac{x}{22.5} \quad x = 5.8$$

This 5.8 in does not account for the radius of the wheel which is 3 in. After subtracting, the difference in height of the two wheels to cause collision is found to be 2.8 in. This is far more than the  $\frac{3}{4}$  in maximum height of the threshold.

With this maximum calculated the calculations regarding to the elevator can be ignored. Even with the worst case scenario of an error of  $\frac{1}{2}$  in, is even less of a problem than the  $\frac{3}{4}$  in threshold we have just shown can be easily cleared. The last issue would be the ramp and the two potentially problematic areas the beginning and the peak. The ramp must be at most a 12 to 1 slope an angle of about 4.8 degrees. The chassis has a 1 in clearance which accounts for both potential problems the front or the rear of the chassis colliding with the floor. In order for the front of the chassis to collide with the ground before the wheel begins to ascend the ramp the chassis would need to be 12 in from the wheel center. The chassis is 4.5 in from the wheel center easily clearing the beginning of the ramp. The peak of the ramp can be modeled as an isosceles triangle the height of which would have to remain under 1 in to avoid collision. The angle of where the ramp meets the higher level is 85.25 degrees. Since we are modeling this as a triangle the entire angle of ramp top to floor top is needed so 90

degrees is added for an angle of 175.25 degrees. This triangle can now be divided in two in order to find the height and we are left with a triangle with angles 2.375, 87.625, and 90 degrees with one side being 9 in half the distance between wheel centers. The height of this triangle is .37 in well under the 1 in clearance.

## Wheel Pod Design

A common issue and main concern when implementing a mechanical system in any environment is maintenance and the issues it may cause. A device which requires constant maintenance costs the company or organization that purchased it in numerous ways. Maintenance is a costly process which needs to be accounted and budgeted for. While performing maintenance on a device any parts which need to be replaced or updated need to be purchased. A technician needs to be paid for their effort based both on time and the complexity of the maintenance being performed. However, these are not the only areas a consumer would lose money in purchasing a product which requires a good deal of maintenance. The consumer purchased the product to perform a function or service and while the product is undergoing maintenance that function or service is no longer being performed.

For more technical products including computers, robotic platforms, and complex mechanical systems often require specialized maintenance. Workers trained by the manufacturer are often needed to perform the proper maintenance to the product and this specialized assistance comes at the expense of either the consumer or the manufacturer. However, with the distance goods can travel in the modern world, often times manufacturers rely on the consumer mailing the product back to a workshop where the company can perform maintenance with their trained staff. This is very common especially among smaller companies who are not as widespread and therefore do not have the branches in which they can dispatch maintenance personnel.

In order to prevent these expenses to both the consumer and the manufacturing company reliability and ease of maintenance were highly considered in the design process. Wheel pods were designed, one for each wheel which would house the motor and wheel. This allowed for a few important features. Because of having four motors and no linkages in the body of the chassis to connect them the reliability is improved and the complexity is reduced. Linkages can often provide an advantage and eliminate problems in a design, however, for this project they were seen as an extra component which would require maintenance. Linkages require constant maintenance such as lubrication and can be quite complex to an unspecialized maintenance worker if the linkages requires replacement. The current design with a motor for each wheel allows for internally geared motors which can be easily replaced.

These wheel pods would also allow for quick and easy replacement, due to the fact that they could be removed with ease. Two bolts and a secured pin would be the only components attaching the wheel pod to the chassis. Because of this specialized personnel would not be required if wheel pods needed to be removed or attached. These wheel pods are also fairly small and extras could be placed into storage so that in the event of one of the pods breaking a swap could take place on site and have the robotic courier back into normal operation as fast as possible. The broken pod could then be shipped at back to the manufacturer for maintenance. This would greatly reduce shipping costs because of the decreased size and weight as compare to shipping the entire system.

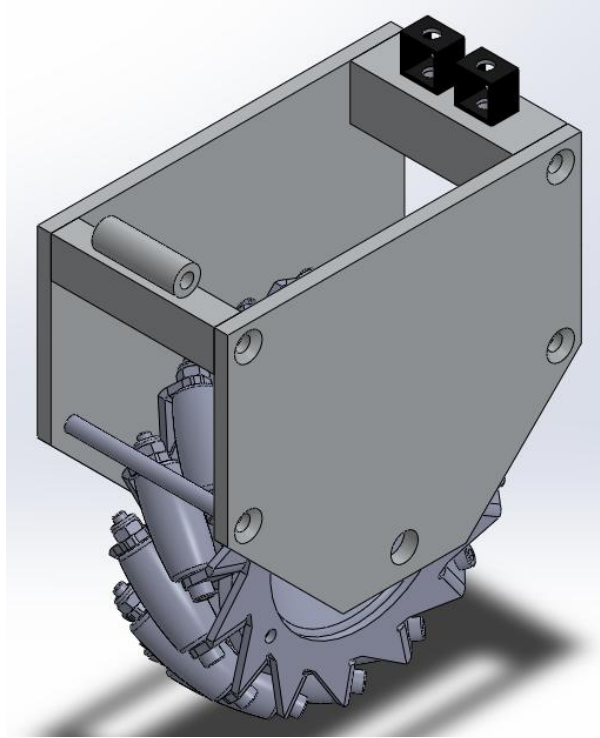

Figure 22: Wheel Pod

## Suspension

This wheel pod design allows for the implementation of a suspension for the system. The pod would be attached to the chassis with a pin and two bolts. The bolts are put through rubber dampers and then attached to the wheel pod in a way that allows for motion up the length of the bolt. The rubber dampers absorb any impact or impulse from the wheels to reduce the impulse imparted on the actual system to provide a more stable platform. This additional dynamic stability will further increase the safety during operation which is always a large concern while operating in a hospital setting. In addition to increased dynamic stability, the use of a suspension will help the Mecanum wheels in operation. Since the wheels rely on the wheel speed and direction of each individual wheel, having a suspension which increases the ability to have consistent wheel-to-floor contact will make the navigation of the system more reliable. The rubber dampers will simply be hollow columns which allow for the

bolts to pass through. Other designs including a U shaped design were researched however, it was determined that in the terrain of a hospital the additional complexity was not needed. These designs may have a larger dampening effect however a hospital setting does not require a highly active suspension. The constant operation of the courier system would cause additional buckling and wear and tear to these dampers causing them to be replaced more often without providing a large amount of improvement.

### FEA on Chassis and Wheel Pods

All information into the FEA done on the chassis and wheel pods can be found in Appendix J: Final CAD Model FEA – Model Information through Appendix M: Wheel Pod FEA Results.

## CHAPTER IV: Manufacturing

This section will describe in detail of how the robot chassis was manufactured and assembled.

Components used in the final construction of this project were purchased from vendors as well as machined by the project group. Once all components necessary for the project were obtained, the chassis was assembled.

### Manufacturing Planning

With the complete Solidworks CAD model completed our group has a better understanding of how the drivetrain will act under certain forces, loads, and situations encountered in operation. Using this information gained through Finite Element Analysis (FEA) we moved forward with the purchase of the components required to fabricate the chassis. The chassis assembly, **Error! Reference source not found.**, is made of several one inch square aluminum tubing which will be welded together. The tubing is being welded together instead of being bolted together to give the chassis a more robust joining which will allow for us to have room to drill holes in the frame to attach some sort of cabinet to the frame or even give us more working room in case of a late redesign. Using the exact dimensions that the group decided on as part of the chassis dimensions we then cut the aluminum tubing to specification. To

ensure the welding process would be completed without issue the aluminum tubing was grinded down and deburred on the sides cut, and cleaned.

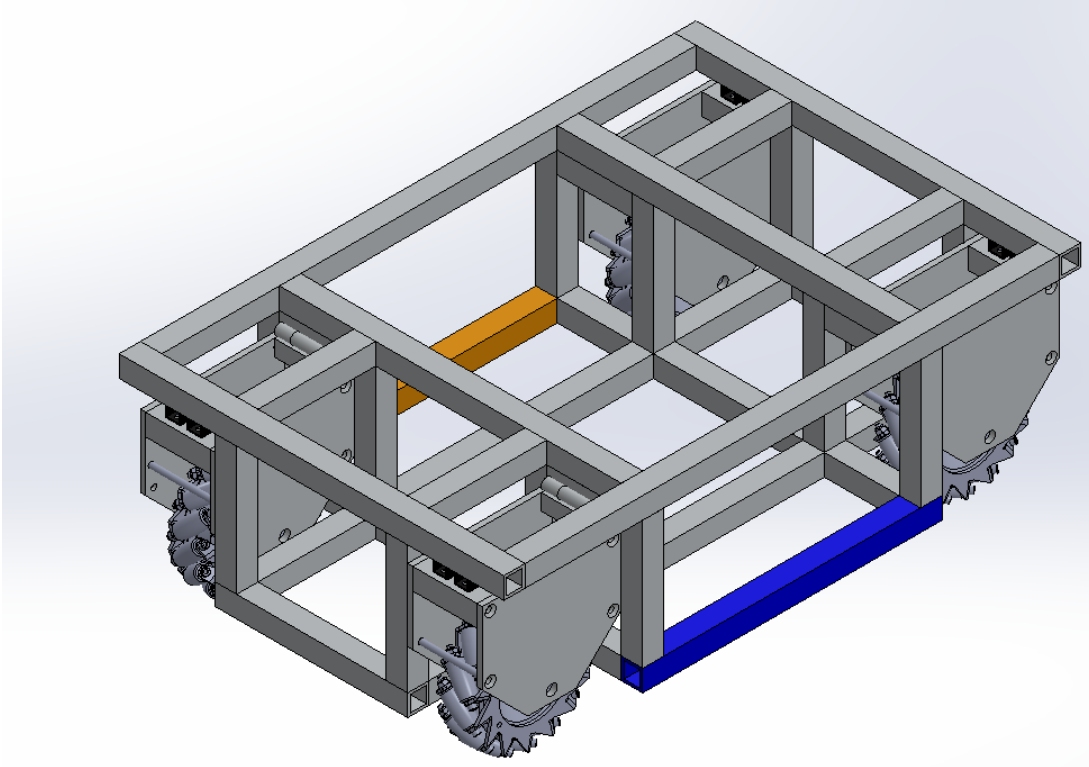

Figure 23: Chassis Frame Solid Works Model

The wheel pods will be constructed of a combination of sheet metal, aluminum tubing, and aluminum rods. The four wheel pods are modular which allows us to make them so they could be mounted in any position with minimal effort required and also so that they can be easily swapped out in the event they need to be serviced. Holes will need to be drilled through sections of the wheel pods in order for bolts to pass through which will be the primary method of assembly for the wheel pods. This was chosen against welding the wheel pods together due to the necessity of swapping any part out of the wheel pod.

In addition the bolts that hold the wheel pod to the chassis are supplemented by rubber shock absorbers which will also help to create a more precise distance from the wheel pod to the chassis. The motors will be mounted to the wheel pods and have small supports giving them better alignment with the shaft. The charging pieces will be mounted to the underside of the chassis in the front of the robot which will be engaged by driving over a spring loaded contact plate on the floor. While the charging pieces are planned for in the design, we will not be implementing them due to the scope of the project. The spring will keep the contacts securely touching and the large area will provide a large margin of error for docking.

## Machined Parts

Some of the parts created for the project were machined by the group from stock pieces of metal. These components were first designed and modeled in Solidworks and FEA analyzed before final machining took place.

## Chassis

The chassis of the robot was designed with the specific requirements of being able to handle a certain amount of weight beyond our practical testing capabilities. This was in part to keep our redesign comparable to what the TUG® currently is able to transport.

## Wheel Pods

The wheel pods of the robot were designed with many key design ideas in mind. With the implementation of a mecanum drive for the robot, the wheels must in some way utilize a sort of shock absorption method otherwise if the robot were to encounter anything other than a smooth flat surface it would have trouble maintaining speed and direction due to the shocks through the system. We built the wheels pods out of ¼ inch aluminum plate. This was done in part to account for the stresses on the wheel pods from the chassis. The wheel pod plates were machined out by milling the plates down to the



specifications, and then we drilled in the mounting holes for the motors, and the holes for the axels and bearings.

### List of Purchased Parts

Many of the components came from various vendors that aided in the fabrication of the project.

List in Table 3 below are the parts ordered that the group in some way had to machine to meet our needs based on the SolidWorks model.

**Table 3 – Purchased Parts for Manufacturing**

<b>Name</b>	<b>Vendor</b>	<b>Part Number</b>	<b>Description</b>
.25 x 6 x 17 6061 Alum	YardeMetals Dropzone	6061-T6511-FL	Aluminum Plate
Aluminum 1" sq tubing	MSC Direct	32000952	Square Tubing
½ aluminum round tube	MSC Direct	32000838	Round Tubing
aluminum round rod	MSC Direct	32011777	Round Rod
Neoprene Spring Blend	MSC Direct	31937626	Rubber Sheet

In addition to ordering stock materials that we machined down for the project, we also had to order components that we ended up using as is. These parts are listed below in Table 4.

**Table 4 – Purchased Parts for Assembly**

<b>Name</b>	<b>Vendor</b>	<b>Part Number</b>	<b>Description</b>
Snow Blower motor	AndyMark	Am-2235	Drive Motor
10mm DD Bore Hub	AndyMark	Am-2279	Direct Drive Hub
24" 12 GA cable	AndyMark	Am-2255	Battery Cable
6" Mechanum Wheel	VexPro	217-2898	4 Mechanum Wheels

Flanged Bearing	VexPro	217-2735	Bearings for Wheels
3/8" Hex Shaft	VexPro	217-2753	Shafts for Wheels
Clamping Shaft Collar	VexPro	217-2739	Shaft Collars
Arduinio + LabView	SparkFun	Dev-11225	Microcontroller

## Final Assembly Process

With the completion of the wheel pods and the chassis frame it was then time to put the entire chassis together. To attach the wheel pods to the chassis we devised a method that allows for us to slide an aluminum rod into part of the wheel pod and the chassis frame which will hold the wheel pod in the proper location. This is coupled with bolting the wheel pod to the chassis in the front of each wheel pod with two bolts going down through the frame and into the shock absorbers and finally into the wheel pod.

## Electrical Wiring

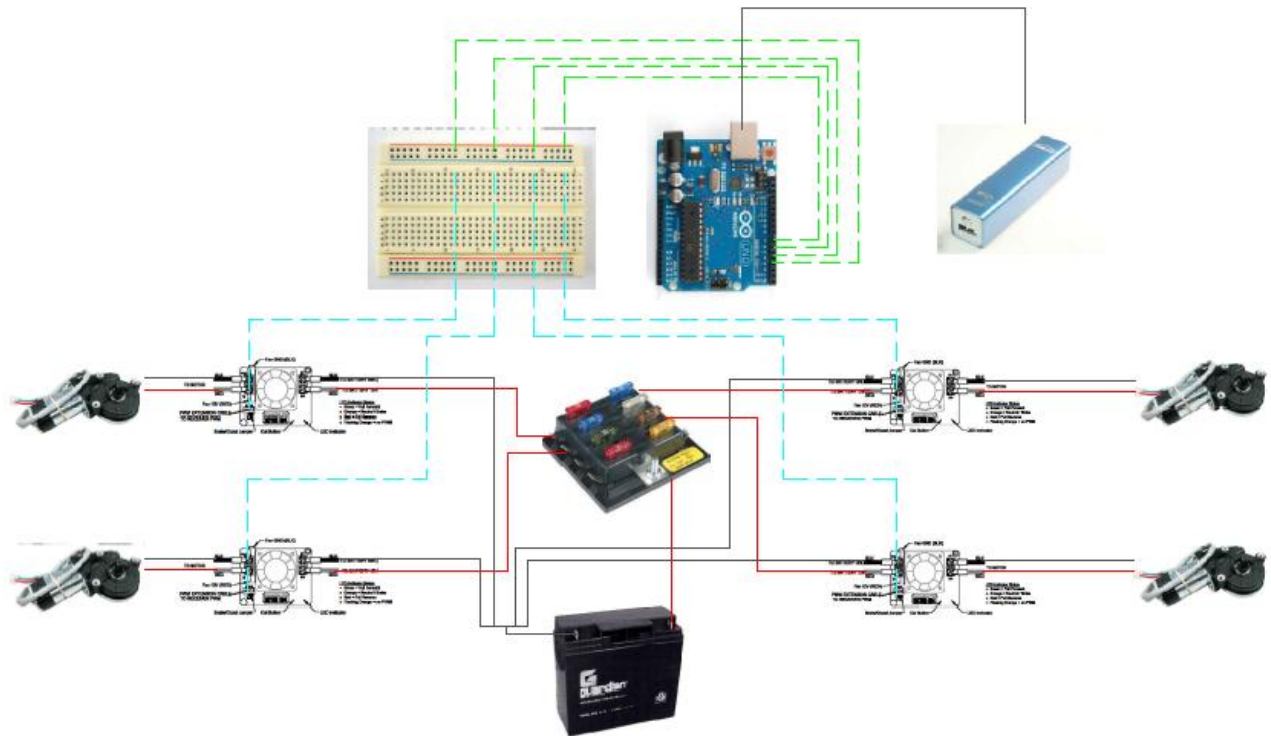

Figure 24 - Electrical Wiring Diagram

As seen in Figure 24 above, the electrical wiring of our robot was pretty straight forward. In Figure 24, the red and black solid lines represent the positive and negative connections between devices which were 12 gauge electrical wiring. The dashed cyan lines represent the PWM cables used to connect the motor controllers to the wiring breadboard, and finally the dashed green lines represent the wiring connections from the arduino to the electrical breadboard.

The wiring of the electrical used a fuse block to handle all of the pure power connections so that in the event of a surge of power from the battery, the fuse block would just pop the fuse out instead of potentially frying the motor controller and motors. The PWM cables used to connect the breadboard and the motor controllers send digital signals to and from the arduino microprocessor telling the motors how fast to spin and in which direction.

## CHAPTER V: Programming the Robot

### Programming Necessity

In order to provide basic controls and do preliminary testing of the design, it was decided that a simple program was needed to demonstrate the robots capability of running autonomously when given instruction. Initially, this was going to be accomplished through the use of a LabView VI program that is explained below. However, due to unforeseen issues in connecting the LabView to the Arduino we had purchased this was eventually deemed ineffective for the task required. Instead, we opted to use Basic C programming directly through the Arduino that not only gave us full control but allowed the robot to be easily programmed with set routines to follow.

### VI Construction

In order to run the robot in the correct direction and orientation, the individual wheels require different voltages depending on three factors, the speed, translation angle, and the rate and direction of rotation. Using the mecanum calculations provided earlier in the paper of the form

$$V_1 = S * \sin((X * (\pi/180)) + (\pi/4)) + R$$

Where  $V_1$  is the output voltage to wheel number 1, S is the speed ranging from -1 for full reverse to 1 for full forward, X is the translation angle in degrees that is then converted to Labview's default setting of radians, and finally R which is the speed of rotation ranging from -1 for full speed counterclockwise to 1 for full speed clockwise. For each wheel there are slight changes to the equation, half of the wheels use cosine instead of sin and half of them subtract the rotation value rather than adding it. All three inputs are on the front page of the VI along with their maximum ranges for the user to specify.

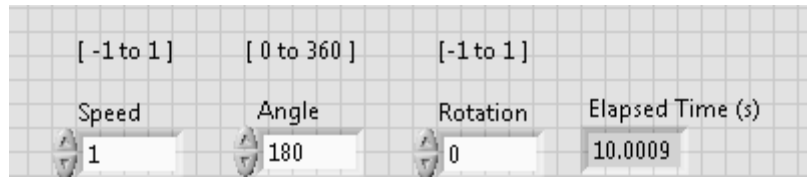

Figure 25 - Labview Input Panel

Using these three inputs and the 4 unique equations Labview output four initial wheel voltages that can range from -2 to 2 depending on the variables used.

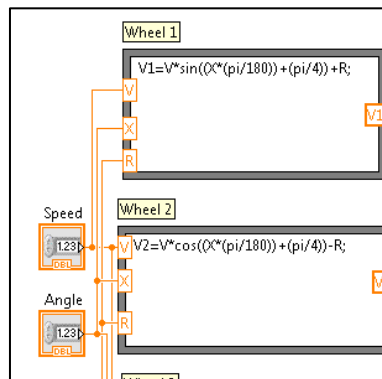

Figure 26 - Sample of Labview Equations

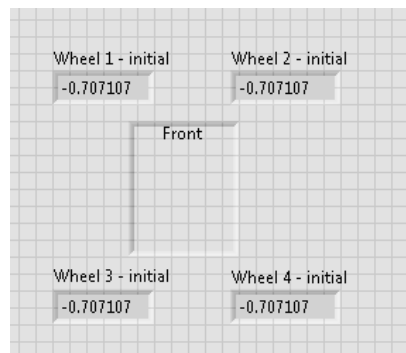

Figure 27 - Initial Wheel Output Values

As the range for wheels can reach from -2 to 2 and the Daq is only capable of limited voltage outputs we need to ensure that we don't peak our voltages because if that occurs the force vectors for the wheels will be incorrect. This leads to the robot moving in unpredictable patterns. In order to prevent this, the next portion of the Labview takes all 4 wheel output values and combines them into a single 4 value

array. This array is entered into a max/min function that checks if each value falls within the range of -1 to 1. If any of the results returns false for the max/min check a signal is sent to a case structure. The case structure functions as an IF/THEN statement within Labview that acts differently depending on whether it receives a "true" or "false" input. If all 4 values are within the se range, the case structure receives a true signal and nothing further is done to the values before extracting them from the array. However if even one value falls outside the range, the case structure receives a false signal which causes the entire array to be divided by a factor of 2. This ensures that even the maximum value of 2 is reduced to 1 which will then fall within range. However, in order to ensure the force vector relations between wheels stays constant and the voltage ratios at each wheel stay constant, every value must be adjusted not just those outside the range. After being reduced, the values are then extracted from the array as a final set of outputs that can be sent to each of the wheels.

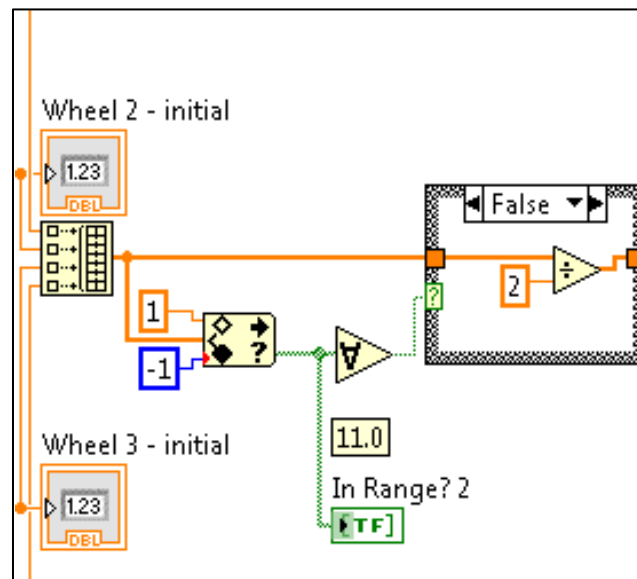

Figure 28 - Scaling Function within Labview

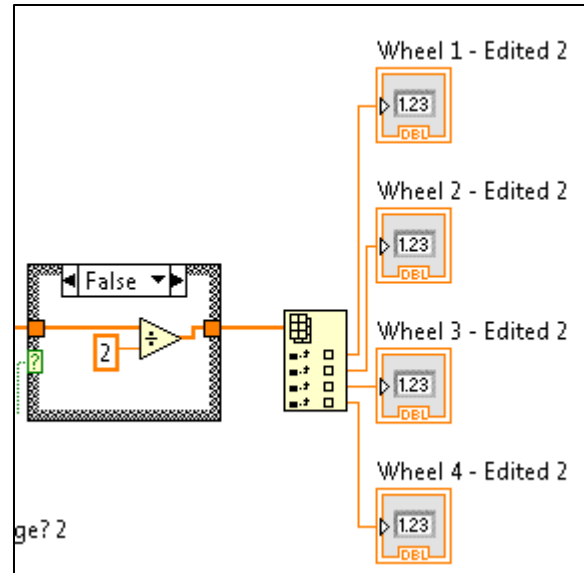

Figure 29 - Extraction from Array

As an extra safety precaution we added a timer into the program. This allows us to enter a specific length of time, after which the program will automatically end regardless of what it is doing. This is to ensure that it won't continue running beyond what we want and also ensure it cannot go too far if we are unable to shut it down ourselves. The full VI and this timer function can be seen this full image below.

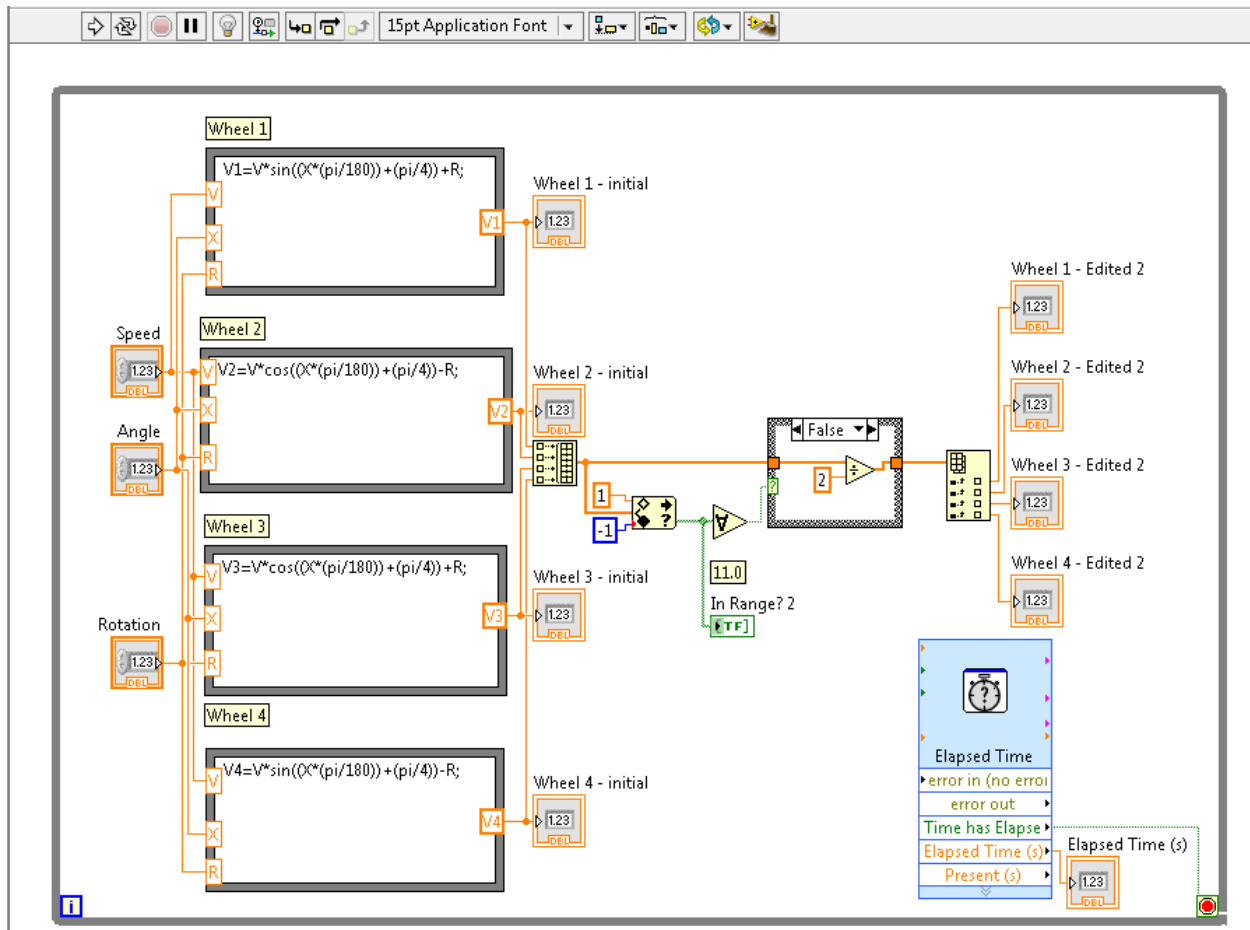

Figure 30 – Final Vi Program

## C Programming in Arduino

Then first step required to program the Arduino in C was to dedicate each output pin on the Arduino to an individual wheel, allowing for 4 signals to be transmitted simultaneously. The wheels were still named V1 through V4 to match with the already established system used earlier in the project. This is accomplished by entering “v#.attach(PIN#)”, as seen in Figure 31. This assigns each wheel to a pin at the start of the program to be used in all future steps.



```
void enable(){  
  v1.attach(3);  
  v2.attach(5);  
  v3.attach(6);  
  v4.attach(9);  
}
```

Figure 31: Attach Code

Once each pin is connected to a wheel, there are 6 different commands which can be used to direct the robot. Each command is programmed into the arduino and can be used at the end of the program to write routines given a command and a time duration to follow each step. For the direction of rotation of each wheel, 180 indicates full forward motion and 0 indicates full reverse. So for forward motion, all wheels are set to run at 180 as seen in Figure 32.

```
void driveForward(int q){  
  for(int a=0; a<1; a++){  
    enable();  
    v1.write(180);  
    v2.write(180);  
    v3.write(180);  
    v4.write(180);  
    delay(q*1000);  
    disable();  
  }
```

Figure 32: Forward Command

To achieve rotation, the wheels on the side being turned towards run in reverse while the far wheels run forwards, I.E. for a right hand turn, the right side wheels run in reverse while the left runs forward as seen in Figure 33.

```

void driveRight(int u){
  for(int b=0; b<1; b++){
    enable();
    v1.write(180);
    v2.write(0);
    v3.write(180);
    v4.write(0);
    delay(u*900);
    disable();
  }
}

```

Figure 33: Right Hand Turn

Finally to achieve lateral translation, the front wheel on the side you wish to translate towards runs in reverse as well as the wheel on the opposite corner, i.E. to translate left the front left and rear right wheels run in reverse while the other two run forwards as shown in Figure 34.

```

void translateLeft(int u){
  for(int b=0; b<1; b++){
    enable();
    v1.write(0);
    v2.write(180);
    v3.write(180);
    v4.write(0);
    delay(u*1000);
    disable();
  }
}

```

Figure 34: Translate Left

Using these 6 given commands a routine can be created by running each step in sequence while using a delay of 1000 milliseconds (1 second) in between steps for safety concerns. All the user needs to indicate is the length of time to execute each action in parentheses following each step. The robot takes approximately 4 seconds to complete a full rotation which means for every second entered on the turn commands, the robot will turn 90 degrees. In the example below the robot moves forwards for 2 seconds and then immediately reverses for another 2 seconds. The robot then rotates clockwise 180 degrees in 2 seconds before rotating another clockwise for 2 seconds to return to its original orientation. Finally the robot translates to the right for 2 more seconds before coming to a stop.

```
void loop() {  
  while(t<1){  
    driveForward(2);  
    delay(1000);  
    driveBackward(2);  
    delay(1000);  
    driveRight(2);  
    delay(1000);  
    driveLeft(2);  
    delay(1000);  
    translateRight(2);  
    delay(1000);  
    disable();  
    delay(5000);  
    t++;  
  }  
}
```

Figure 35: Example Working Code

The disable command at the end disconnects each wheel from the assigned arduino pin, preventing further motion. During testing, various paths were programmed including a square path that was accomplished by two different methods. In the first code, the robot drove forwards for 2 seconds before turning 90 degrees and moving forwards again, repeating this process until the square was completed. Another method involves moving the robot forwards, translating to the left, driving in reverse and finally translating to the right to end at the same starting point. This one path achieved through completely different methods is an excellent demonstration of the flexibility of the program as it currently stands and the various ways it allows the user to accomplish any task. The full code is available in the appendices of the report.

## Testing Procedures

To evaluate the robotic courier, the team conducted a series of test that analyzed how well the device complies with the design specifications as well as how well it compares to the current TUG system. Each design specification was carefully chosen to either improve upon the benchmark TUG system or to meet and exceed the requirements to operate the robotic courier in a hospital

environment. Each of these design specifications is broken up into two types of tests. The first type of test is a pass/fail test for specifications such as size or weight which do not require analysis. Any specification which is not qualified as pass/fail test will undergo a performance test. This type of test will require multiple trials to determine a performance rating. After completing all tests, the results will be analyzed to determine what aspects of the device, if any could be reworked and improved to provide a better product. Finally, a demonstration path will be created to show that the device operates correctly and to display the improvement in features as compared to the benchmark TUG system.

The demonstration path will be created to show that the design operates correctly and will display features which the design has improved upon when compared to the benchmark TUG system. On Aethon's website they claim that the TUG system has a turning radius of 31.7 inches. The West Roxbury VA hospital has hallways which are 8 feet wide which provides the TUG barely enough room to make a U turn. However, hallways can be as tight as six feet wide which the TUG cannot negotiate. Having a width of 26.5 inches the TUG requires a width of 90 inches or about 7.5 feet to make a U-turn. This turning radius causes additional issues in elevators which have a minimum width of 80 inches which the TUG cannot negotiate with a U-turn. In a crowded hospital setting the elevators are frequently used and if the TUG requires the entire elevator to turn around it does not allow for additional passengers. The turning radius is also at the forefront of the issue in that it can encounter obstacles which it cannot pass. Our path will show improvements in these areas including maneuvering a situation which the TUG could not and displaying a zero turn radius showing that the elevator may be used with the new system.

First we will describe the task specifications and testing protocol which we recommend for the fully completed robot. Unfortunately this project was not able to realize this final goal due to time, funding, and backgrounds. This project can be furthered in years to come by future projects which may have the additional funding necessary to bring the project to fruition. After the task specifications and

testing protocol we will describe the task specifications and testing protocol which we have used to evaluate the project pertaining to our scope.

## Task Specifications

1. The new chassis design should be capable of handling all of the situations the current design encounters.
  - a. Must be able to handle a maximum load of 500 lbs in addition to the weight of the cabinet.
  - b. Must be able to climb a slope of 6 degrees on a smooth tiled surface.
  - c. Must be able to transition from tile to carpet smoothly.
  - d. Must be capable of traveling at least 2.5 miles per hour. (Speed limited within hospital environment).
  - e. Must be able to traverse sudden changes in surface elevation such as door stops or small gaps such as those in elevator doors.
  - f. Must not tip unless tilted beyond 10 degrees in any direction.
  - g. Must be able to charge while requiring little to no modification of the current wall outlet charging station.
  - h. Must have at least 0.75" of ground clearance at its lowest point.
2. The new design should maintain similar dimensions to the existing design to ensure the current cabinet designs can be mounted properly.
3. Robot should be simple enough to be maintained by the hospital staff with outside service only being required annually.

- a. The wheel pods will be connected with a pinned hinged to the chassis for simplified maintenance. Should a wheel or motor need to be replaced it will only require basic hand tools to remove the existing pod and insert a spare in its place.
  - b. Regular maintenance such as cleaning and simple lubrication can be done by the hospital staff monthly or as needed.
  - c. Batteries, motors and wheels should need to be replaced no more than once per year.
4. Battery life must be sufficient to last for multiple trips in succession without the need for a recharge.
    - a. The average round trip transportation is between 15-20 minutes. When the hospital is at its busiest the robots may be required to transport multiple samples with no stops in between. The battery life must be enough to finish all of these trips and return to the nearest charging station.
  5. The robot should be capable of detecting and maneuvering around an obstacle in its designated path.
    - a. Able to move laterally in order to bypass an obstruction before returning to the set route.
    - b. Can rotate in place to quickly change direction while requiring less space than the current design.
  6. The robot must have both an emergency stop and emergency release button that is both easily visible and easily accessible to anyone.
    - a. Emergency stop button will hold the robot in place and pause all routes until it is undone and allowed to resume.
    - b. Emergency release will unlock all wheels allowing the robot to be moved aside in case of emergency.

7. The robot should be able to stop in less than 2 feet when required.
8. The robot should not endanger those nearby
  - a. Sharp edges will be covered or rounded. Any pinch points will be kept out of reach.
  - b. Low speeds will ensure no harm is caused from collisions with the robot.

## Testing Protocols

In order to ensure that our design meets all the task specifications as listed we will conduct a series of tests to ensure that as many specifications as possible are reached. These will be conducted under carefully designed scenarios in order to have full control over the results and remove any outside interference.

1. The new chassis design should be capable of handling all of the situations the current design encounters.
  - a. To test this set of requirements the robot will be run through a simulated hallway environment in one of the campus academic buildings. A 30 foot slope of 6 degrees will be used to ensure the robot can climb the slope while still maintaining speed at a full 500 pound load.
  - b. The robot will be placed on a 10 degree ramp and be made to move along both axes to ensure it will not tip.
  - c. The robot will be driven over doorstops and into an elevator, as well as over a transition from carpet to tile, to ensure it can overcome changes in floor elevation.
2. Robot should be simple enough to be maintained by the hospital staff with outside service only being required annually.

- a. An outside participant will be asked to remove the wheel pod from the assembly and provided with various hand tools. The removal will be timed and the participant will be asked to describe how difficult the process is. Multiple tests can be conducted with some participants receiving prior instruction and others being given none at all.
3. Battery life should be sufficient for multiple trips.
    - a. In order to simplify this test, we can make use of the zero turn radius and set the robot to constantly rotate in one direction for a set amount of time. This will provide a constant drain on the batteries and enable us to time how long it takes for them to fully drain. Other options would be to program a set path that can be constantly looped and again time how long the batteries last.
  4. The robot should be capable of detecting and maneuvering around an obstacle in its designated path.
    - a. A path will be programmed and run by the robot first to ensure there are no issues with the path designation. Afterwards, the path will remain unchanged but obstacles will be added for the robot to navigate past.
    - b. In addition, the stopping distance of the robot can be measured during this time in order to ensure it can stop quickly enough when a hazard is detected.

For the scope of this project the areas which will be tested can be seen below. These tests lay out the requirements of the drivetrain of the robot so that future projects can move forward and be successful.

1. The new chassis design should be capable of handling all of the situations the current design encounters.
  - a. To test this set of requirements the robot will be run through a simulated hallway environment in one of the campus academic buildings. A 30 foot slope of 5 degrees will



- be used to ensure the robot can climb the slope while still maintaining speed at a full 500 pound load.
- b. The robot will be placed on a 10 degree ramp and be made to move along both axes to ensure it will not tip.
  - c. The robot will be driven over doorstops and into an elevator, as well as over a transition from carpet to tile, to ensure it can overcome changes in floor elevation.
2. Robot should be simple enough to be maintained by the hospital staff with outside service only being required annually.
    - a. An outside participant will be asked to remove the wheel pod from the assembly and provided with various hand tools. The removal will be timed and the participant will be asked to describe how difficult the process is. Multiple tests can be conducted with some participants receiving prior instruction and others being given none at all.
  3. The robot should not endanger those nearby
    - a. An outside participant will be asked to look over the robot for sharp edges, pinch points, and other potentially dangerous features.
    - b. The speed will be measured to ensure that the speed is in acceptable ranges for hospital safety.
  4. With the use of labview the maneuverability of the robot should be ready for demonstration to aid in the furthering of the project.
    - a. An outside participant will be asked to review the labview software and then plot a course for the robot to take. This will be evaluated in both correctness and interface.

## CHAPTER VI: Testing Results

1. The new chassis design should be capable of handling all of the situations the current design encounters.

- a. The robot will be tested to ensure that it is capable of demonstrating the mobility of a mecanum drivetrain.

**Results:** The robot successfully demonstrated the ability to move forward, backward, rotate with a zero turn radius both left and right, and translate from side to side. This successfully demonstrates the extreme maneuverability of the mecanum drivetrain.

- b. To test this set of requirements the robot will be run through a simulated hallway environment in one of the campus academic buildings. A 30 foot slope of 5 degrees will be used to ensure the robot can climb the slope while still maintaining speed at a full 500 pound load.

To test this specification, the robot will traverse a 5 degree, 30 foot incline (ramp at the WPI fitness center). This was repeated five times to compile and average the data. The test was rated pass or fail. If the device failed then the distance that the device traveled was measured and recorded.

**Results:** The robot was able to traverse the ramp to the full 30 feet each time. Although the concrete surface and the outdoor environment are not ideal for a mecanum drive it had no problems traversing the full ramp each time without slipping or failure.

- c. The robot will be placed on a 10 degree ramp and be made to move along both axes to ensure it will not tip.
- d. The robot will be driven over doorstops and into an elevator, as well as over a transition from carpet to tile, to ensure it can overcome changes in floor elevation.

To test both of these specifications the robot will be required to accelerate on the ramp and traverse the ramp at full speed as well as traverse the appropriate obstacles. This will occur along both axes to ensure proper function. This test was rated pass fail and the result can be seen below.

**Results:** The robot showed the ability to overcome changes from hardwood to carpet and easily traversed a doorstop of 1 inch in height; ada requirements limit the height to  $\frac{3}{4}$  inch, proving its ability to traverse the unavoidable obstacles on the floor. The robot was also tested on multiple surfaces such as tile, hardwood, and carpet. These surfaces proved no problem even while maneuvering on two different surfaces at once. The robot was also able to accelerate up and down a 10 degree ramp without showing any signs of tipping or the wheels lifting off the floor. However, this test was conducted without the proper cabinet system in place and therefore the results are not completely conclusive.

2. Robot should be simple enough to be maintained by the hospital staff with outside service only being required annually.

To test this specification an outside participant will be asked to remove the wheel pod from the assembly and provided with various hand tools. The removal will be timed and the participant will be asked to describe how difficult the process is. Multiple tests can be

conducted with some participants receiving prior instruction and others being given none at all.

**Results:** Due to the welder in the WPI machine shop being broken for several weeks the wheel pods were not able to be completed to the original design. With no additional funding to go elsewhere for welds and the extreme backup once the welder was fixed the wheel pods were attached using alternative methods and this test was ignored.

3. The robot should not endanger those nearby
  - a. An outside participant will be asked to look over the robot for sharp edges, pinch points, and other potentially dangerous features.

To test this specification an outside participant will be asked to look over the robot for sharp edges, pinch points, and other potentially dangerous features. The participant will then rate the safety of the device on a scale from 1-5 with 5 being completely safe and 1 being a hazard. This test will be completed multiple times with different participants.

**Results:** Five participants ranked the robot at 2, 3, 3, 3, and 3 respectively. This overall does not meet the requirements which our team would like to see before putting this into a hospital setting. However, we feel that as a demonstration piece the robot is more than safe enough. There is no present danger in handling or operating the robot.

- b. The speed will be measured to ensure that the speed is in an acceptable range for hospital safety.

To test this, the velocity at full power will be recorded. This data was then compared to the velocity of the TUG robot which is already deemed to operate at a safe speed.

**Results:** The robot was tested by running it at full speed for 4 seconds, due to space constraints, and measuring the total distance traveled. Once calculated, the top speed of the robot in its current state is 1.56 mph compared to the TUG which has a top speed of 2.5 mph. As a demonstration piece the speed is enough to view the function and is below the safe benchmark speed of 2.5 mph.

4. With the use of the arduino code the maneuverability of the robot should be ready for demonstration to aid in the furthering of the project.

To test this specification an outside participant will be asked to review the arduino code and then plot a course for the robot to take. Upon completion the participant will be asked to rate the accuracy of the robot and the ease of the interface from 1 to 5 with 1 being the worst and 5 being the best.

**Results:** Five participants were quickly taught the arduino code so that they could edit a route for themselves and then rate the accuracy of the system. The ease of interface was ranked 5,5,4,5, and 5 which demonstrates the ease of operation and extremely low learning curve. All participants had no prior knowledge of coding or robotics and were able to learn and program a path in under five minutes. The accuracy of the task given to it was ranked 4, 5, 3, 5, and 3 which shows that the robot would be able to

demonstrate a basic path and would perform better with additional tweaking. The two lowest scores were each on routes with a large amount of extra turning. Since the code currently runs each command for a certain time and not to a specific angle the turning had small errors. These errors then compiled the more turning was called for which lead to larger errors with more turning heavy tasks.

## **CHAPTER VII: Discussion**

The current set up of the robot serves as a useable demonstration piece which can be quickly and easily programmed to maneuver a designed path. The interface can be quickly and easily edited with minimal time to learn the interface. Overall, the prototype met the main design criteria and was able to be easily controlled while demonstrating the maneuverability of the mecanum drivetrain. Testing was able to further confirm these accomplishments.

The tests demonstrated the maneuverability of the mecanum drive and the robot was capable of motion forward, backward, translate right, translate left, spin clockwise, and spin counter clockwise. The robot demonstrated the ability to traverse a terrain under ada requirements and showed the ability to transition to and from carpet and other surfaces with ease. The test for the ease of maintenance was removed due to the welder in the WPI machine shop being broken for several weeks the wheel pods were not able to be completed to the original design. With no additional funding to go elsewhere for welds and the extreme backup once the welder was fixed the wheel pods were attached using alternative methods and this test was ignored. However, the wheel pod is design in such a way that two bolts and a pin need to be removed and one wire disconnected to replace a wheel pod. Our team feels as though with common tools an average maintenance worker would be able to replace a wheel pod once shown how to complete the task.

The robot was ranked fairly low in safety due to the fact that it is not yet ready for a hospital setting. However, as a prototype and demonstration piece there is no danger in operating or handling the device and these safety issues can be fixed in the final product by making sure to grind down cuts and corners further to improve safety. The test participants had little trouble learning the interface with the arduino code and were able to plot a course which they wanted with fairly high accuracy. Participants were able to create a wide variety of paths and all said that the interface was very easy to learn and understand. The accuracy of the task given to it was ranked 4, 5, 3, 5, and 3 which shows that the robot would be able to demonstrate a basic path and would perform better with additional tweaking. The two lowest scores were each on routes with a large amount of extra turning far beyond what would be required in any actual function or demonstration. Since the code currently runs each command for a certain time and not to a specific angle the turning had small errors. These errors then compiled the more turning was called for which lead to larger errors with more turning heavy tasks.

## **CHAPTER VIII: Recommendations**

One large concern towards this project was funding due the expensive nature of robotics components. While this group attempted to gain addition funding through various organizations on campus that extend funding to groups that require it, none of those opportunities came through. While we were able to secure a small addition to our operational budget, it proved to still be too little. Electrical components required to prove that our projects functionality work came up short, and caused us to find alternatives as a work around. Recommendations would be to find a set sponsor that is interested in seeing the practical application of a mecanum drive system in an everyday setting. This would help to alleviate the majority of problems that our group encountered during this project.

While we were able to successfully assemble a chassis however, there is always room for improvement in manufacturing. While this project group was limited by the knowledge of how to weld consistently, the welding could be improved on the chassis by either having a certified welder or a robotic welder weld the frame together. Another area for improvement would be to heat treat the chassis frame after welding it to prevent the frame from losing structural integrity from the effects of welding.

Also, the purchasing of 3/8 inch hex shaft was not our group's ideal choice, but given the availability of 1/2 inch stock we would recommend using the slightly larger stock. In addition, the wheel pods are attached to the chassis using a rod that we deemed to be deficient at the long term job of holding the pod to the chassis frame. While for the limited testing purposes of our group, the final product would require a large pin holding the wheel pod to the chassis as the wheel pod is taking a lot of normal force from the ground, and a being secured to the chassis frame better would provide a better peace of mind against failure in the metal holding the project together.

Due to the tight budget of the project and the intent that this be a proof of concept and a demonstration piece for future projects the coding was done in the arduino in C. The robot is currently capable of performing any movement function for a set amount of time and in any order to demonstrate the maneuverability and agility of a mecanum drive. With more knowledge of robotics and proper coding, the addition of motion while turning and angled translations could be added to the system for future projects.

With the incorporation of future projects the project can be seen through to a final marketable product. Future projects should build a cabinet unit or a substitute so that a sensor array can be incorporated for obstacle avoidance. Future projects should integrate a method of uploading autocad



floor plans to the robot for ease of delivery path selection. Future projects should incorporate SLAM (simultaneous localization and mapping) or similar programming to make the robot fully autonomous.

## CHAPTER IX: Conclusions

The primary goal was to evaluate robotic couriers for design and operation in a hospital environment and to create a robot drivetrain that is more robust and maneuverable than current robotic couriers. These drivetrain improvements allow couriers to efficiently complete functions they were designed to accomplish. Existing drivetrain systems were evaluated through decision and design matrices to choose a drivetrain which could most benefit this application. A mecanum drive was chosen due to several factors including mobility, reliability, and maintenance among others. The prototype satisfies the maneuverability requirement with an interface which is simple and straightforward. Through testing it was shown that this system can be taught to someone who has no prior knowledge or background in any robotics or coding area and have them give a demonstration of the capabilities of a mecanum drivetrain.

Overall, the primary goals were achieved for this first generation prototype. The chassis is capable of supporting more than the required payload, mecanum drivetrain is extremely maneuverable, the wheel pods are designed to be modular and easily replaceable, the tipping angle was improved by 17.65% over the TUG, arduino code is in place and easy to use for demonstration purposes, and a fully completed prototype was constructed for testing and demonstration purposes. Though there are some flaws in the device, the team is confident that this robot can be a successful demonstration piece and with the recommendations provided, future projects could complete the robot to a marketable product.

## BIBLIOGRAPHY

Aethon. "Aethon." *Aethon*. N.p., 2012. Web. 12 Sept. 2012. <<http://www.aethon.com/>>.

Krass, Madison and Sayre, Fred. "FRC Drive Train Design and Implementation." PowerPoint Presentation. World Congress Center, Atlanta, GA. 17 April 2008.

*Net Force of Mecanum Drive*. Digital image. *Imageshack*. Pifrank, n.d. Web. 23 Apr. 2013.

Norton, Robert L. "Chapter 1: Introduction." *Design of Machinery: An Introduction to the Synthesis and Analysis of Mechanisms and Machines*. Boston: McGraw-Hill Higher Education, 2004.

<http://www.access-board.gov/adaag/html/adaag.htm#4.13>

Wilczynski, Vince, Stephanie Slezycski, Dean Kamen, and Woodie Flowers. *FIRST Robots: Behind the Design*. Gloucester, MA: Rockport, 2007. Print.

# APPENDIX

## Appendix A: FBDs

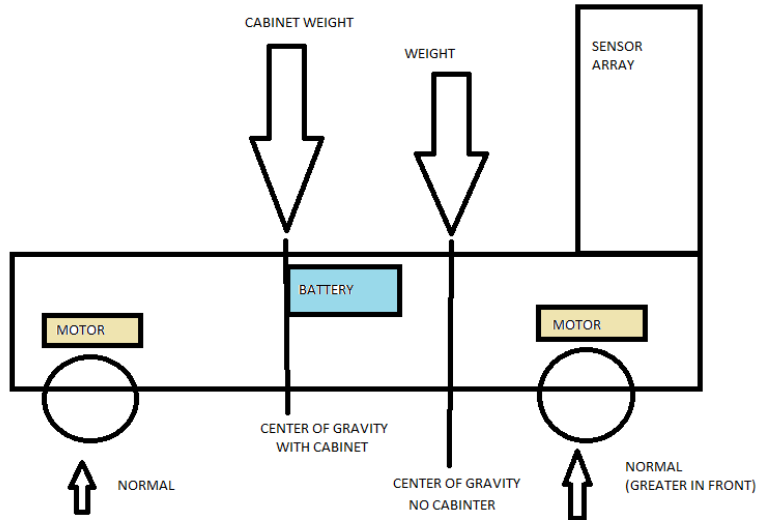

Figure 36 - FBD of Robot

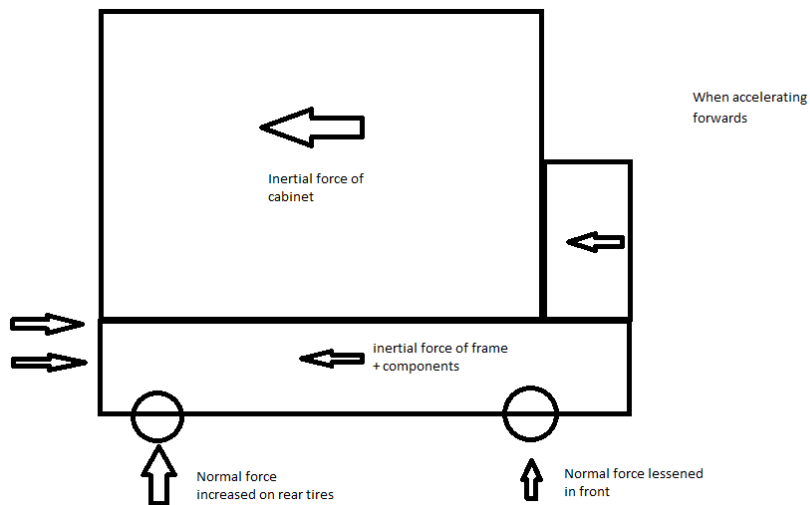

Figure 37 - FBD of Acceleration

## Appendix B: Project Timeline Gant Chart

Table 5 - Project Gant Chart

	A - Term (1st)	A- Term (2nd)	B - Term (1st)	B - Term (2nd)	C - Term (1st)	C - Term (2nd)
Interviewing						
Preliminary Research						
Specific Research						
Solidworks Model						
Manufacturability Analysis						
Cost Analysis						
Materials Selection						
Fabrication						
Construction						
Programming						
Reiterations						
Analysis						
Conclusion						
Paper						

## Appendix C: Cost Tables

Green Shaded Cells Denote products most similar to those used in the TUG®

Table 6 - Motor Cost

Model	Stall Torque	RPM	Voltage	Price	Store
SOYO 24V DC Gear Motor	.04 fl-lb	18,000 rpm	24V	\$ 81.41	Robot Shop
Banebot FIRST CIM 12V	1.78 ft-lb	5310 rpm	12V	\$ 28.00	Robot Shop
FIRST CIM 12V	1.78 ft-lb	5310 rpm	12V	\$ 28.00	AndyMark
FIRST CIM 12V	1.78 ft-lb	5310 rpm	12V	\$ 27.99	VexRobotics
Pittman Series GM9000 DC Gearmotors	4.74 ft-lb	127rpm	24V	\$ 158.20	Automation Express
AmpFlow F30-400 Motor	13 ft-lb	2400 rpm	24V	\$ 239.00	TheRobotMarketPlace
DeWalt 24V Hammerdrill Motor	16 ft-lb	21000 rpm	24V	\$ 61.99	TheRobotMarketPlace
PG71 Gearmotor	16.6 ft-lb	75 rpm	12V	\$ 59.00	AndyMark
PDX256 - 256:1 Gearmotor	116 ft-lb	90 rpm		\$ 99.99	TheRobotMarketPlace

Table 7 - Potential Batteries

Model	Voltage	Amp Hours	Quantity	Price	Vendor
Batteries MK ES17-12 12V 17aH	12V	17aH	2	79	AndyMark
Quad Cell 4S Nanophosphate 26650 Lithium-Ion	13.2V	2.3 aH	1	89.9	Robot Market Place
12V - 12AH Lead acid battery	12V	12 AH	4	24.99	Buy.com

Table 8 - Electrical Components

<b>Part</b>	<b>Quantity</b>	<b>Price</b>	<b>Vendor</b>
Power Distribution Board	1	\$ 189.00	AndyMark
120 Amp Breaker	1	\$ 29.00	AndyMark
20 Amp Snap Breaker	1	\$ 6.00	AndyMark
10 Amp Snap Breaker	5	\$ 6.00	AndyMark
Black Jaguar Bundle - Speed Controler	5	\$ 119.00	AndyMark
Robot Power Cable Kit	1	\$ 50.00	AndyMark

Table 9 - Wheel Cost

<b>Mecanum Wheels</b>		<b>Size</b>	<b># in set</b>	<b>Price</b>	<b>Retailer</b>
	AndyMark	6"	4	\$ 253.00	AndyMark
	AndyMark	8"	4	\$ 459.00	AndyMark
	AndyMark	10"	4	\$ 710.00	AndyMark
	AndyMark	8"	4	\$ 305.00	Robot Shop
	AndyMark	6"	4	\$ 253.00	Robot Shop
<b>Omni Wheels</b>					
	AndyMark	6" Single	1	\$ 28.00	AndyMark
	AndyMark	6" Double	1	\$ 100.00	AndyMark
	AndyMark	8" Single	1	\$ 42.00	AndyMark
<b>Pneumatic Wheels</b>					
	AndyMark	8"	1	\$ 29.00	AndyMark
<b>FIRST Wheels</b>					
	AndyMark	6"	1	\$ 10.00	AndyMark
	AndyMark	8"	1	\$ 20.00	AndyMark
<b>Traction Wheels</b>					
	AndyMark	6"	1	\$ 29.00	AndyMark
	AndyMark	8"	1	\$ 33.00	AndyMark
	IFI Traction Wheel	6"	1	\$ 49.95	VexRobotics
	IFI Traction Wheel	8"	1	\$ 59.95	VexRobotics

	Colson Performa	6"	1	\$ 7.75	TheRobotMarketPlace
	Colson Performa	8"	1	\$ 10.50	TheRobotMarketPlace
	Colson Performa	4"	1	\$ 4.99	TheRobotMarketPlace
	Performance Rubber-Tread	4"	1	\$ 12.62	McMasterCarr
	Performance Rubber-Tread	6"	1	\$ 17.32	McMasterCarr
	Banebot Hex Head	3.875"	1	\$ 6.05	Robot Shop
	<b>Casters</b>				
	Ezy-Roll Casters	4"	1	\$ 24.71	McMasterCarr
	Ezy-Roll Casters	6"	1	\$ 27.35	McMasterCarr



## Appendix D: Atheon TUG® Robot



Figure 38 - TUG Robot

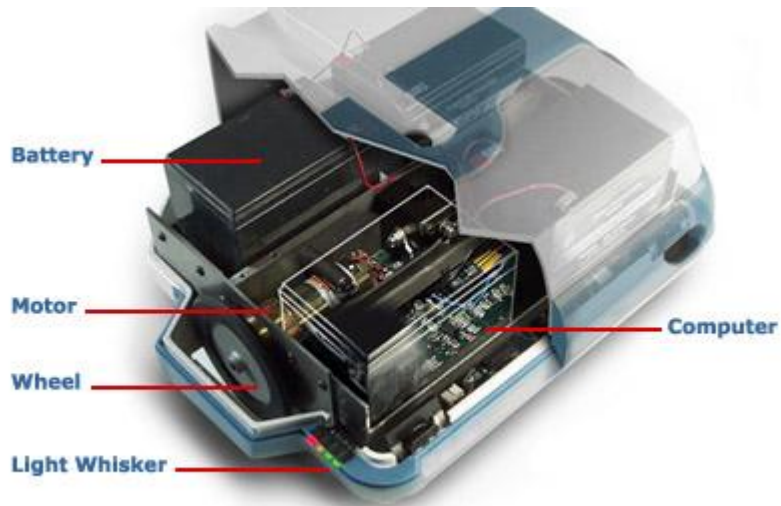

Figure 39 - TUG Inside Details

## Appendix E: Robot Chassis

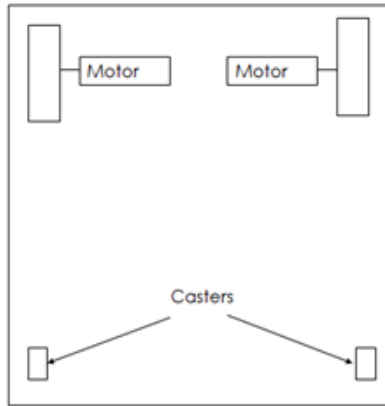

Figure 40 – Skid Steer (two wheels + motors with casters)

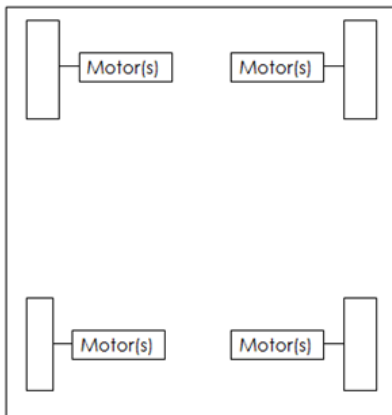

Figure 41 – Skid Steer (four motors + wheels)

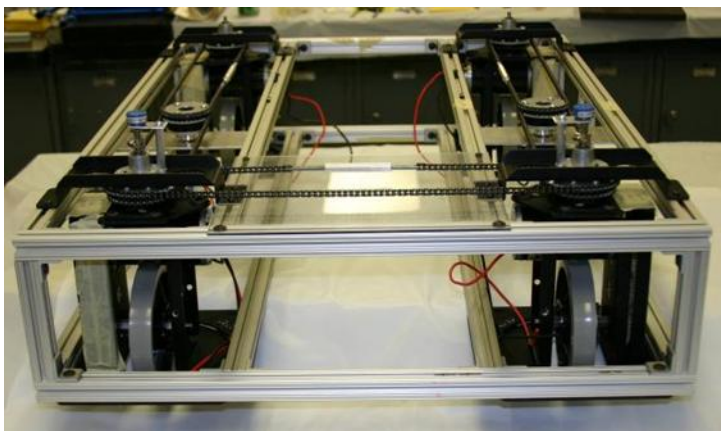

Figure 42 – FIRST Robotic Swerve Drive

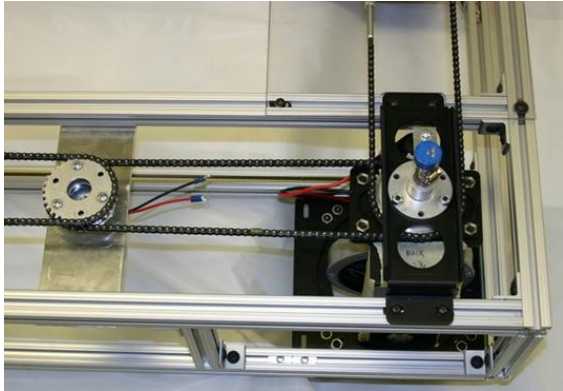

Figure 43 - Swerve Drive Detail



Figure 44 – Mecanum Wheel Pod



Figure 45 - Single omniwheel



Figure 46 - Double omniwheel

## Appendix F: ADA Ramp Standards

Excerpt from 28 CFR Part 36:

ADA Standards for Accessible Design

### 4.5 Ground and Floor Surfaces.

**4.5.1 General:** Ground and floor surfaces along accessible routes and in accessible rooms and spaces including floors, walks, ramps, stairs, and curb ramps, shall be stable, firm, slip-resistant, and shall comply with 4.5. [Appendix Note](#)

**4.5.2 Changes in Level:** Changes in level up to 1/4 in (6 mm) may be vertical and without edge treatment (see [Fig. 7\(c\)](#)). Changes in level between 1/4 in and 1/2 in (6 mm and 13 mm) shall be beveled with a slope no greater than 1:2 (see [Fig. 7\(d\)](#)). Changes in level greater than 1/2 in (13 mm) shall be accomplished by means of a ramp that complies with [4.7](#) or [4.8](#).

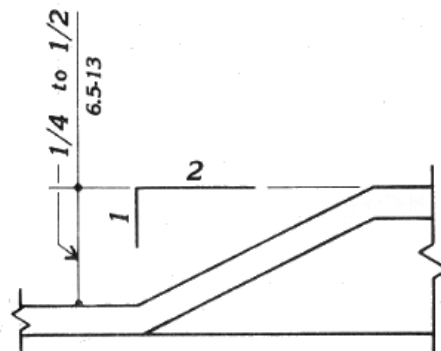

Figure 47 - Accessible Route Changes in level

**4.5.3 Carpet:** If carpet or carpet tile is used on a ground or floor surface, then it shall be securely attached; have a firm cushion, pad, or backing, or no cushion or pad; and have a level loop, textured loop, level cut pile, or level cut/uncut pile texture. The maximum pile thickness shall be 1/2 in (13 mm)

(see [Fig. 8\(f\)](#)). Exposed edges of carpet shall be fastened to floor surfaces and have trim along the entire length of the exposed edge. Carpet edge trim shall comply with [4.5.2. Appendix Note](#)

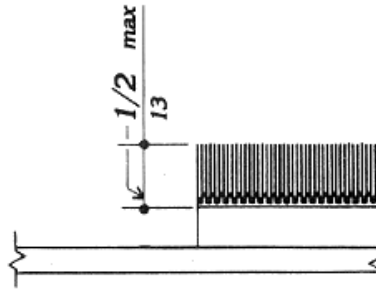

Figure 48 - Carpet Pile Thickness

**4.5.4 Gratings:** If gratings are located in walking surfaces, then they shall have spaces no greater than 1/2 in (13 mm) wide in one direction (see [Fig. 8\(g\)](#)). If gratings have elongated openings, then they shall be placed so that the long dimension is perpendicular to the dominant direction of travel (see [Fig. 8\(h\)](#)).

## 4.8 Ramps.

**4.8.1 General.** Any part of an accessible route with a slope greater than 1:20 shall be considered a ramp and shall comply with 4.8.

**4.8.2 Slope and Rise:** The least possible slope shall be used for any ramp. The maximum slope of a ramp in new construction shall be 1:12. The maximum rise for any run shall be 30 in (760 mm) (see Fig. 16). Curb ramps and ramps to be constructed on existing sites or in existing buildings or facilities may have slopes and rises as *allowed in 4.1.6(3)(a)* if space limitations prohibit the use of a 1:12 slope or less.

**4.8.3 Clear Width.** The minimum clear width of a ramp shall be 36 in (915 mm).

**4.8.4 Landings:** Ramps shall have level landings at bottom and top of each ramp and each ramp run.

Landings shall have the following features:

- 1) The landing shall be at least as wide as the ramp run leading to it.
- 2) The landing length shall be a minimum of 60 in (1525 mm) clear.
- 3) If ramps change direction at landings, the minimum landing size shall be 60 in by 60 in (1525 mm by 1525 mm).
- 4) If a doorway is located at a landing, then the area in front of the doorway shall comply with 4.13.6.

**4.8.6 Cross Slope and Surfaces:** The cross slope of ramp surfaces shall be no greater than 1:50. Ramp surfaces shall comply with 4.5.

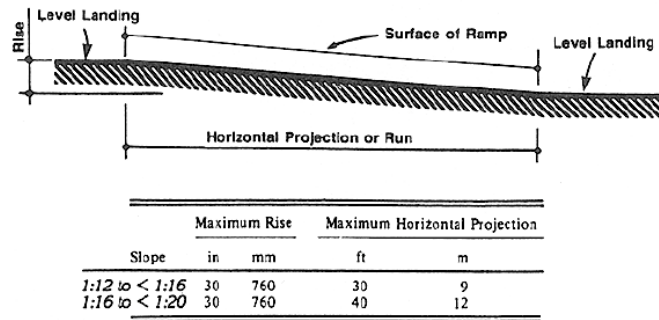

**Fig. 16**  
Components of a Single Ramp Run and Sample Ramp Dimensions

Figure 49- Components of a Single Ramp Run

## Appendix G: Velocity of a Point for Mecanum Drive

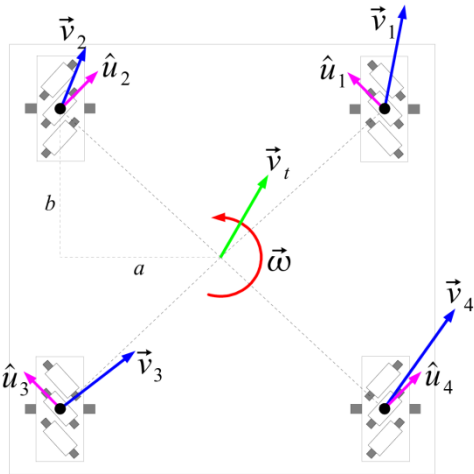

Figure 50 - Velocity of a Point for Mecanum

$$V_{w1} = V_{ty} - V_{tx} + w(a + b)$$

$$V_{w2} = V_{ty} + V_{tx} - w(a + b)$$

$$V_{w3} = V_{ty} - V_{tx} - w(a + b)$$

$$V_{w4} = V_{ty} + V_{tx} + w(a + b)$$

$V_w$  = Speed of the wheel in direction it is facing (ft/s)

$V_{tx}$  = Forward speed of robot (ft/s)

$V_{ty}$  = Lateral speed of robot (ft/s)

$W$  = rotational speed of robot (rad/s)



## Appendix H: Final CAD Model

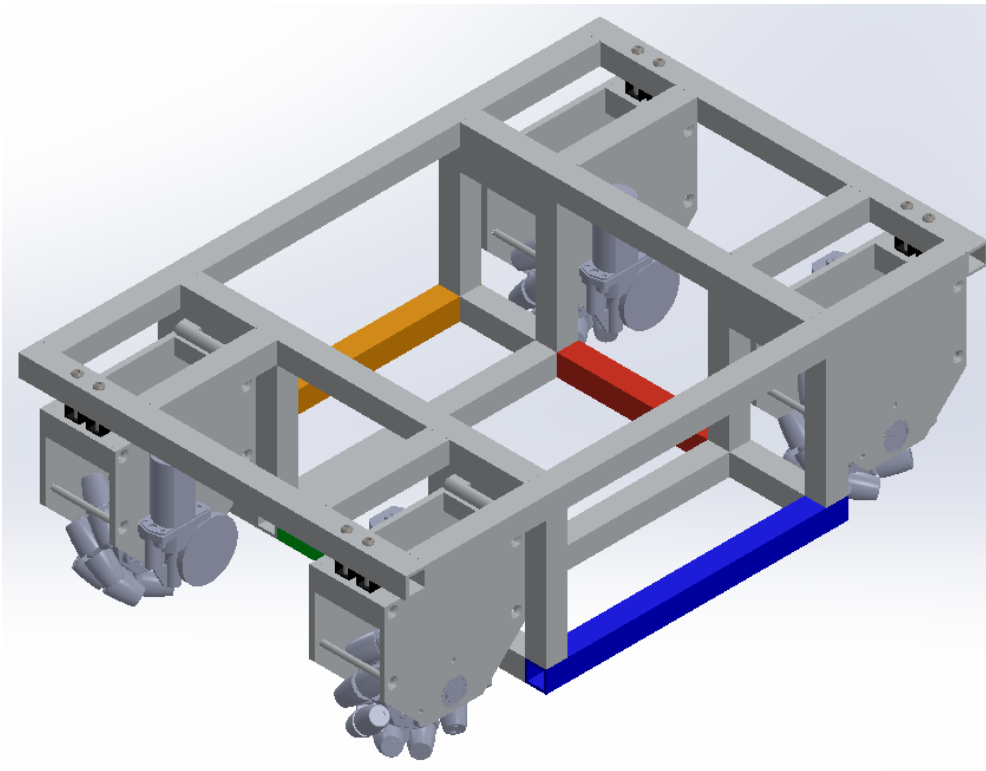

Figure 51 – Final Chassis Isometric View

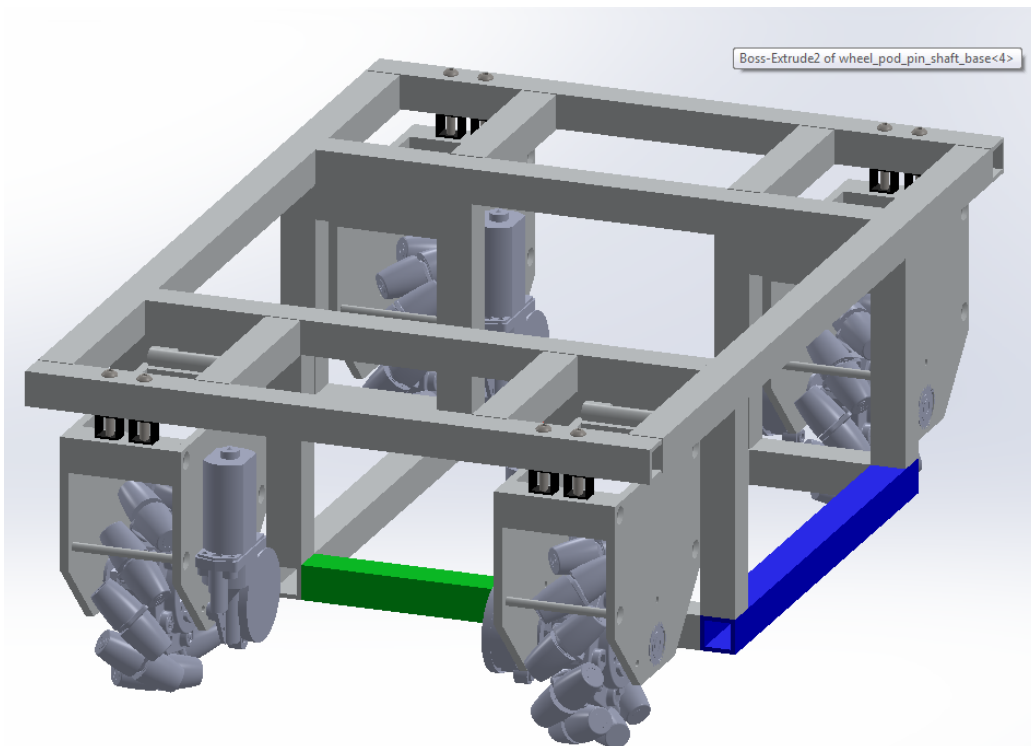

Figure 52 – Final chassis design

## Appendix I: Final CAD Model - Mass Properties

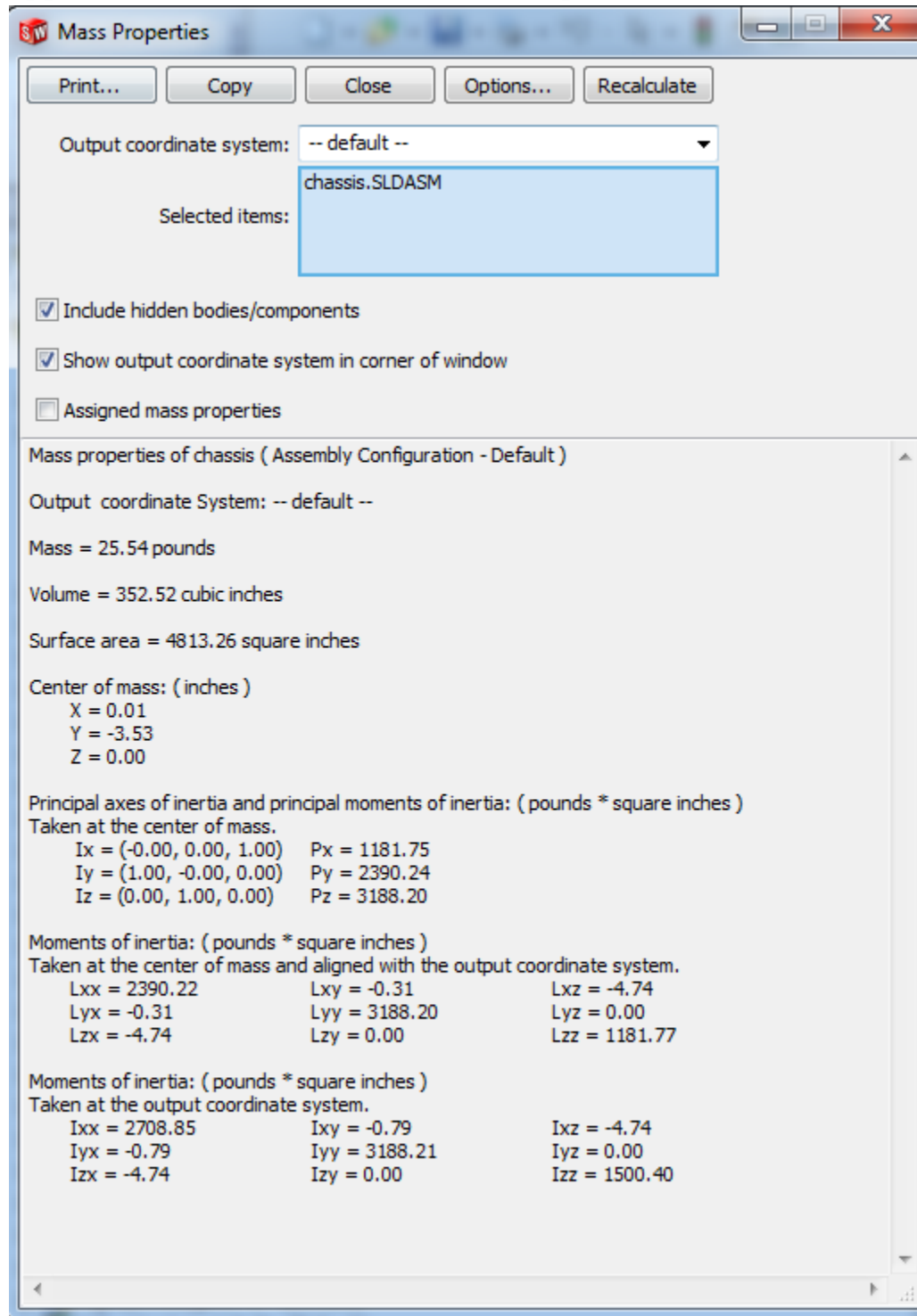
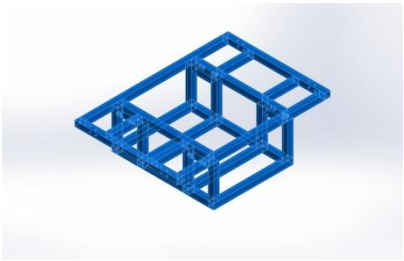

Figure 53 – Mass properties of chassis unloaded

## Appendix J: Final CAD Model FEA – Model Information

### Material Properties

Model Reference	Properties	Components
	Name: <b>6063-O</b> Model type: <b>Linear Elastic Isotropic</b> Default failure criterion: <b>Max von Mises Stress</b> Yield strength: <b>5e+007 N/m<sup>2</sup></b> Tensile strength: <b>9e+007 N/m<sup>2</sup></b> Elastic modulus: <b>6.9e+010 N/m<sup>2</sup></b> Poisson's ratio: <b>0.33</b> Mass density: <b>2700 kg/m<sup>3</sup></b> Shear modulus: <b>2.58e+010 N/m<sup>2</sup></b> Thermal expansion coefficient: <b>2.34e-005 /Kelvin</b>	All
Curve Data:N/A		

### Loads and Fixtures

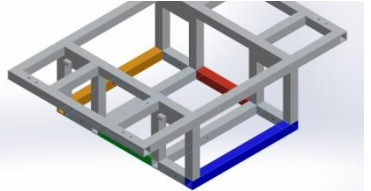
Fixture name	Fixture Image	Fixture Details		
Fixed-2		Entities: <b>10 face(s)</b> Type: <b>Fixed Geometry</b>		
Resultant Forces				
Components	X	Y	Z	Resultant
Reaction force(N)	-0.107017	2056.5	0.37742	2056.5
Reaction Moment(N-m)	0	0	0	0

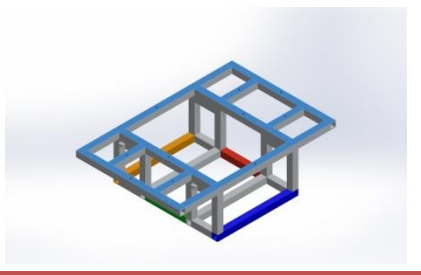
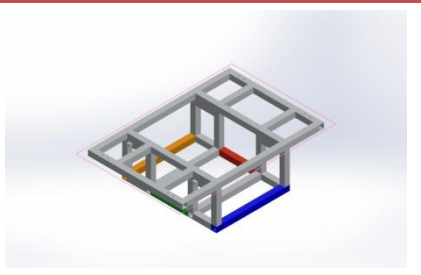
Load name	Load Image	Load Details
Force-1		<b>Entities:</b> 10 face(s) <b>Type:</b> Apply normal force <b>Value:</b> 450 lbf
Gravity-1		<b>Reference:</b> Top Plane <b>Values:</b> 0 0 -9.81 <b>Units:</b> SI

## Resultant Forces

### Reaction Forces

Selection set	Units	Sum X	Sum Y	Sum Z	Resultant
Entire Model	N	-0.107017	2056.5	0.37742	2056.5

### Reaction Moments

Selection set	Units	Sum X	Sum Y	Sum Z	Resultant
Entire Model	N-m	0	0	0	0

## Appendix K: Final CAD Model FEA

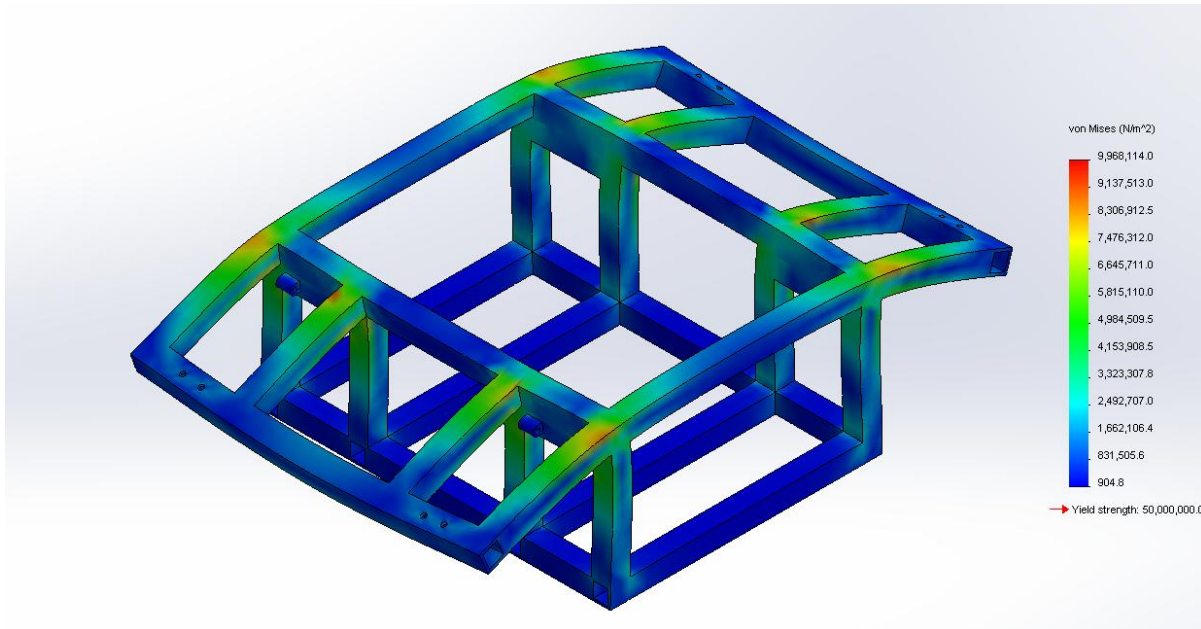

Figure 54 – Displacement on Chassis

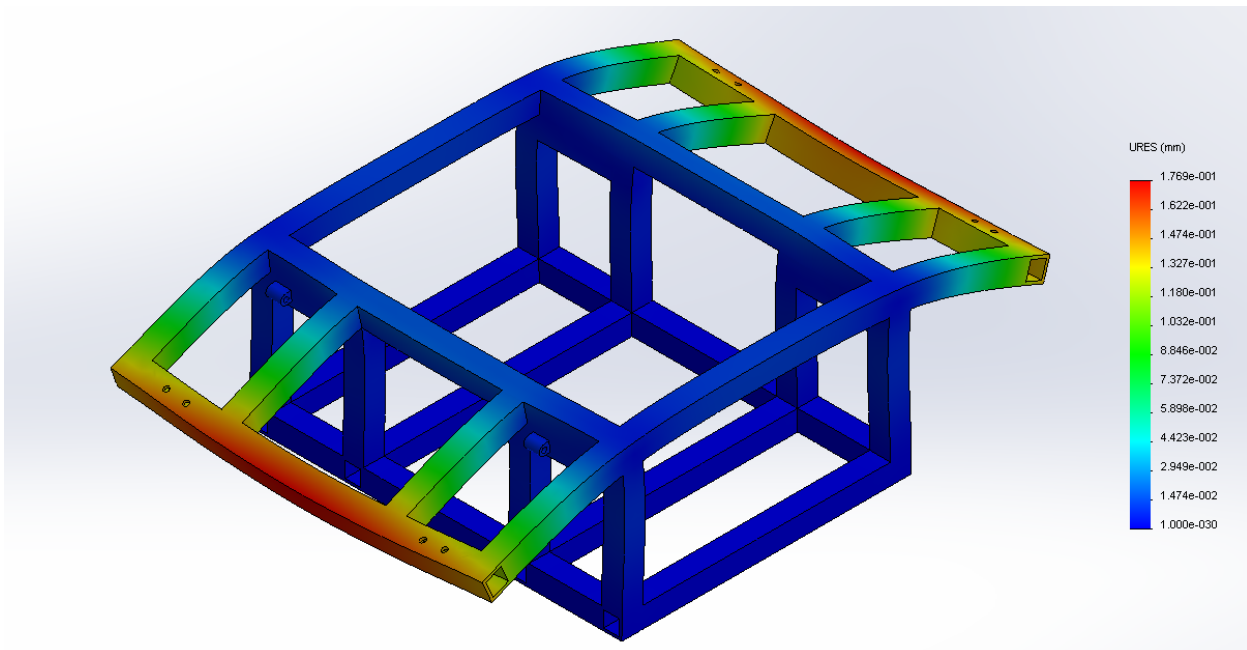

Figure 55 – Displacement on Chassis

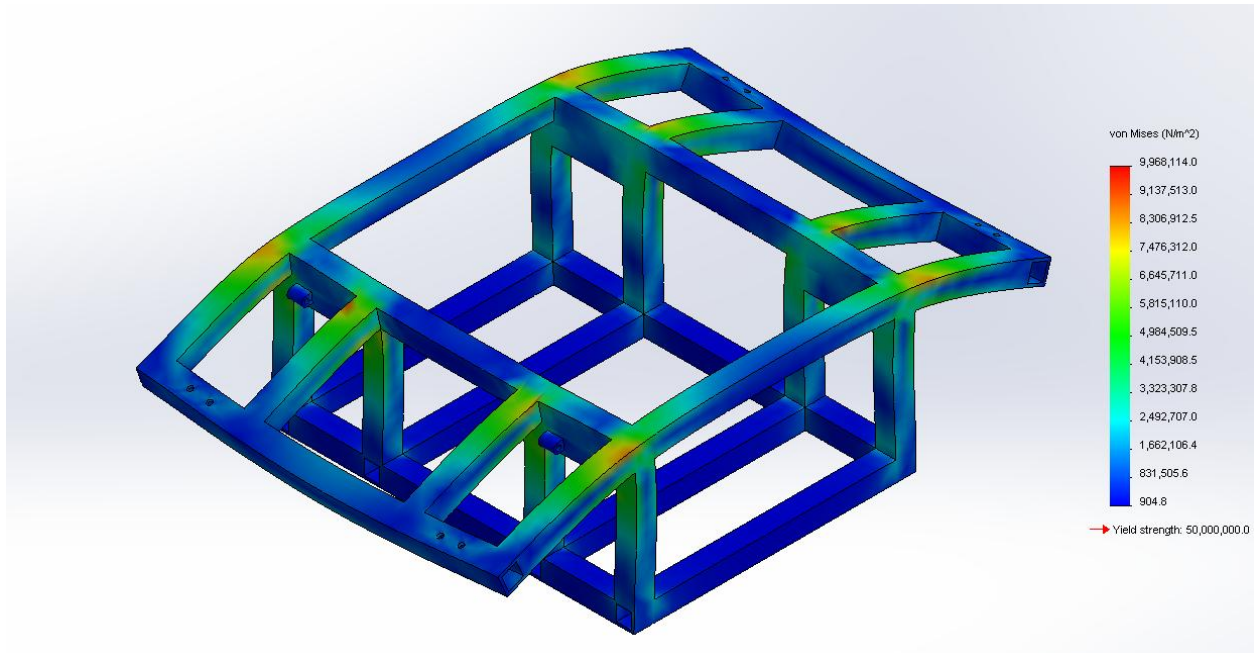
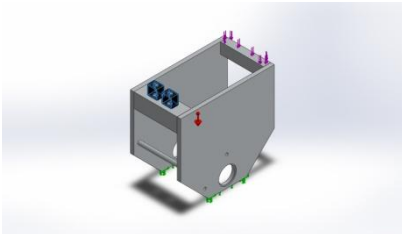
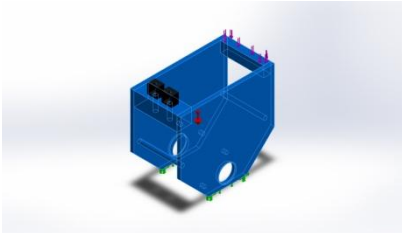

Figure 56 – Stress on Chassis

## Appendix L: Wheel Pod FEA – Model Information

### Material Properties

Model Reference	Properties	Components
	Name: <b>Rubber</b> Model type: <b>Linear Elastic Isotropic</b> Default failure criterion: <b>Unknown</b> Yield strength: <b>9.23737e+006 N/m<sup>2</sup></b> Tensile strength: <b>1.37871e+007 N/m<sup>2</sup></b> Elastic modulus: <b>6.1e+006 N/m<sup>2</sup></b> Poisson's ratio: <b>0.49</b> Mass density: <b>1000 kg/m<sup>3</sup></b> Shear modulus: <b>2.9e+006 N/m<sup>2</sup></b> Thermal expansion coefficient: <b>0.00067 /Kelvin</b>	<b>SolidBody 1(1/4 (0.25) Diameter Hole1)(shocks-1), SolidBody 1(1/4 (0.25) Diameter Hole1)(shocks-2)</b>
Curve Data:N/A		
	Name: <b>1060 Alloy</b> Model type: <b>Linear Elastic Isotropic</b> Default failure criterion: <b>Unknown</b> Yield strength: <b>2.75742e+007 N/m<sup>2</sup></b> Tensile strength: <b>6.89356e+007 N/m<sup>2</sup></b> Elastic modulus: <b>6.9e+010 N/m<sup>2</sup></b> Poisson's ratio: <b>0.33</b> Mass density: <b>2700 kg/m<sup>3</sup></b> Shear modulus: <b>2.7e+010 N/m<sup>2</sup></b> Thermal expansion coefficient: <b>2.4e-005 /Kelvin</b>	<b>SolidBody 1(Boss-Extrude2)(wheel_pod_pin_shaft-1), SolidBody 1(1/4 (0.25) Diameter Hole1)(wheel_pod_pin_shaft_support-1), SolidBody 1(Boss-Extrude1)(wheel_pod_shaft-1), SolidBody 1(Boss-Extrude1)(wheel_pod_shaft-4), SolidBody 1(1/4 (0.25) Diameter Hole1)(wheel_pod_side-1), SolidBody 1(1/4 (0.25) Diameter Hole1)(wheel_pod_side-2)</b>
Curve Data:N/A		

## Loads and Fixtures

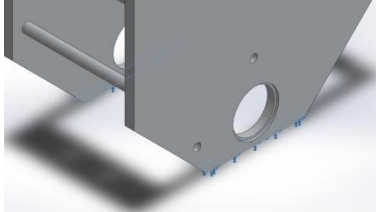
Fixture name	Fixture Image	Fixture Details		
Fixed-1		<b>Entities:</b> 2 face(s) <b>Type:</b> Fixed Geometry		
<b>Resultant Forces</b>				
Components	X	Y	Z	Resultant
Reaction force(N)	-0.0455828	564.969	-0.013193	564.969
Reaction Moment(N-m)	0	0	0	0

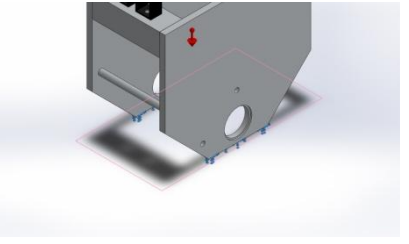
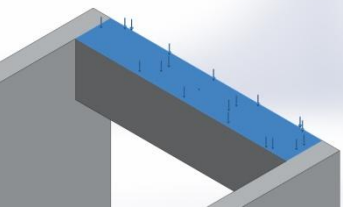
Load name	Load Image	Load Details
Gravity-1		<b>Reference:</b> Top Plane <b>Values:</b> 0 0 -9.81 <b>Units:</b> SI
Force-1		<b>Entities:</b> 1 face(s) <b>Type:</b> Apply normal force <b>Value:</b> 125 lbf

## Resultant Forces

### Reaction Forces

Selection set	Units	Sum X	Sum Y	Sum Z	Resultant
Entire Model	N	-0.0455828	564.969	-0.013193	564.969

### Reaction Moments

Selection set	Units	Sum X	Sum Y	Sum Z	Resultant
Entire Model	N-m	0	0	0	0



## Appendix M: Wheel Pod FEA Results

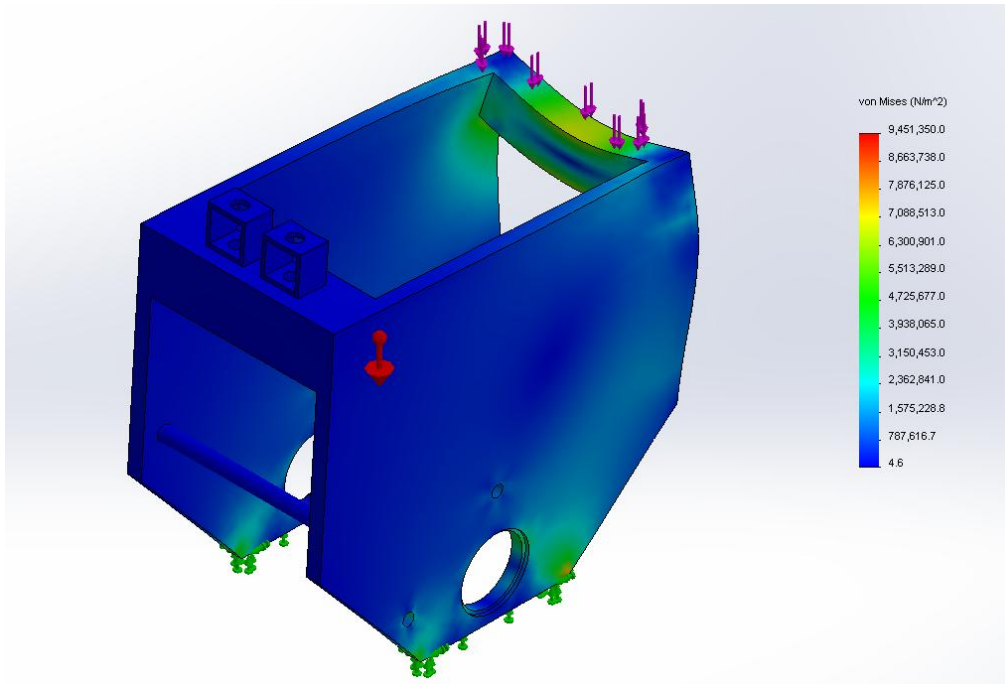

Figure 57 – Stress of Wheel Pod

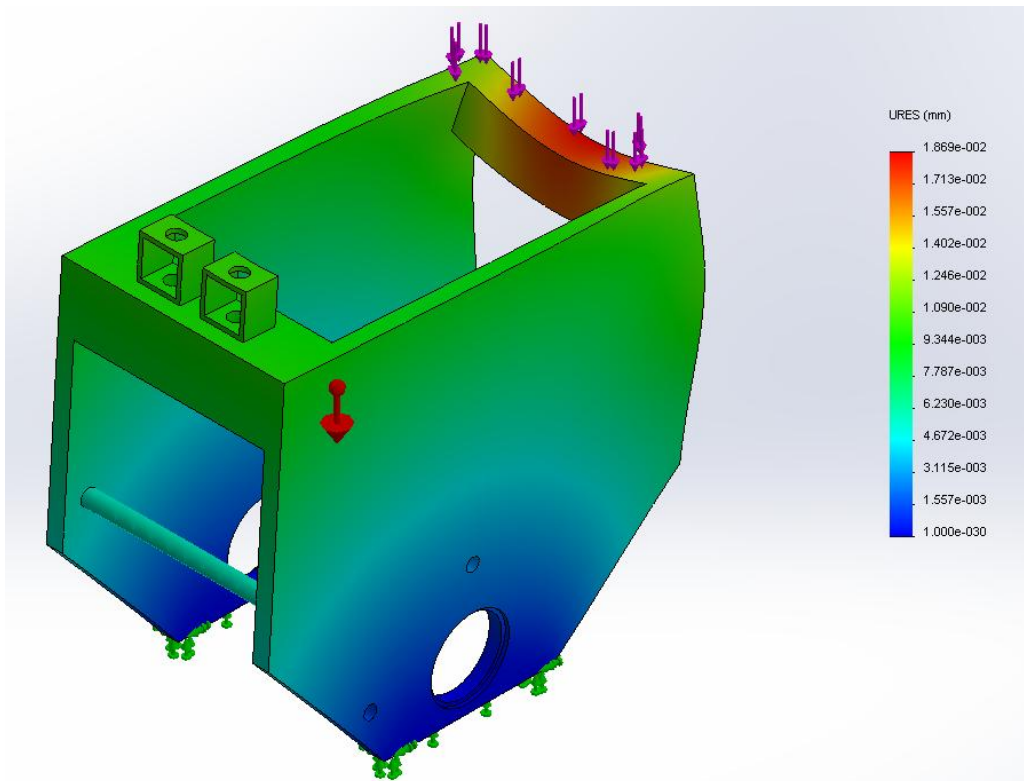

Figure 58 – Displacement of Wheel Pod

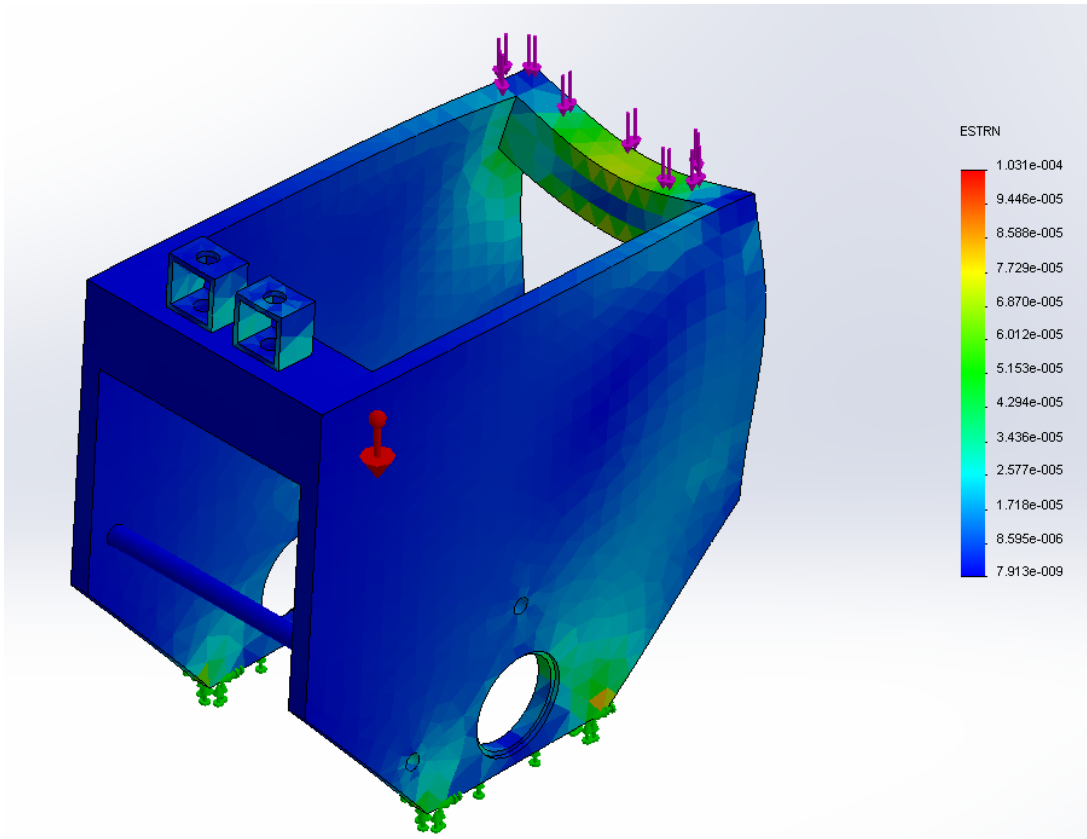

Figure 59 – Strain on Wheel Pod

## Appendix N: Arduino Code

```
#include <Servo.h>

Servo v1;
Servo v2;
Servo v3;
Servo v4;
int t=0;

void disable(){
  v1.detach();
  v2.detach();
  v3.detach();
  v4.detach();
}

void enable(){
  v1.attach(3);
  v2.attach(5);
  v3.attach(6);
  v4.attach(9);
}

void driveForward(int q){
  for(int a=0; a<1; a++){
    enable();
    v1.write(180);
    v2.write(180);
    v3.write(180);
    v4.write(180);
    delay(q*1000);
    disable();
  }
}

void driveBackward(int u){
  for(int b=0; b<1; b++){
    enable();
    v1.write(0);
    v2.write(0);
    v3.write(0);
    v4.write(0);
    delay(u*1000);
    disable();
  }
}
```

```
void driveRight(int u){
  for(int b=0; b<1; b++){
    enable();
    v1.write(180);
    v2.write(0);
    v3.write(180);
    v4.write(0);
    delay(u*900);
    disable();
  }
}
```

```
void driveLeft(int u){
  for(int b=0; b<1; b++){
    enable();
    v1.write(0);
    v2.write(180);
    v3.write(0);
    v4.write(180);
    delay(u*900);
    disable();
  }
}
```

```
void translateLeft(int u){
  for(int b=0; b<1; b++){
    enable();
    v1.write(0);
    v2.write(180);
    v3.write(180);
    v4.write(0);
    delay(u*1000);
    disable();
  }
}
```

```
void translateRight(int u){
  for(int b=0; b<1; b++){
    enable();
    v1.write(180);
    v2.write(0);
    v3.write(0);
    v4.write(180);
    delay(u*1000);
    disable();
  }
}
```

```
void setup()
{

}

void loop() {
while(t<1){
  driveForward(2);
  delay(1000);
  driveBackward(2);
  delay(1000);
  driveRight(2);
  delay(1000);
  driveLeft(2);
  delay(1000);
  translateRight(2);
  delay(1000);
  disable();
  delay(5000);
  t++;
}

}
```

## Appendix O: Demonstration Videos

Links to video demonstrations of various robot tests.

[https://www.dropbox.com/s/q9njzlu6iqfzrdo/IMG\\_0244%5B1%5D.MOV](https://www.dropbox.com/s/q9njzlu6iqfzrdo/IMG_0244%5B1%5D.MOV) :basic demonstration

[https://www.dropbox.com/s/trvi2k862s86wsy/IMG\\_0248%5B1%5D.MOV](https://www.dropbox.com/s/trvi2k862s86wsy/IMG_0248%5B1%5D.MOV) :Carpet/Hardwood

[https://www.dropbox.com/s/zn51f2ntqfyp8i7/IMG\\_0246%5B1%5D.MOV](https://www.dropbox.com/s/zn51f2ntqfyp8i7/IMG_0246%5B1%5D.MOV) :Square Path

[https://www.dropbox.com/s/xqyu4c8h01cla30/IMG\\_0247%5B1%5D.MOV](https://www.dropbox.com/s/xqyu4c8h01cla30/IMG_0247%5B1%5D.MOV) :Square Path Alternate