

Worcester Polytechnic Institute

Facilitating Mathematics Education Through Automatic Reassessment and Retesting

An Interactive Qualifying Project
Submitted to the Faculty of
WORCESTER POLYTECHNIC INSTITUTE
In partial fulfillment of requirements for the
Degree of Bachelor of Science

By

Anthony Spangenberger

Tin Myo Win

Date: May 1, 2011
Project number: NTH 1003



Advisor: Professor Neil Heffernan

Table of Contents

Abstract.....	2
Introduction	3
ASSISTments.....	7
Experiment.....	10
Setting and Participants	10
Content	10
Experimental Design	12
Procedure.....	14
Results.....	14
Discussion.....	24
Conclusion.....	28
Acknowledgements.....	31
References	32
Appendix A: Problem Sets for Mastery.....	33
Appendix B: Post-tests	34

Abstract

This Interactive Qualifying Project involved the design and fulfillment of a study pertaining to the education of eighth-grade math students by computer-based tutoring (the ASSISTments system). The experiment evaluated the effect of combining mastery learning with retesting and relearning in an experimental group compared to control that receives only mastery training. Data produced by the study shows that by using the ASSISTments program to retest students they are capable of gaining significantly greater retention than control while requiring less educator involvement.

Introduction

Mathematics education is an integral part of the curriculum in primary education, a part which many students struggle to attain comprehension of, let alone mastery. The disconnection between the knowledge students *should* have and *do* have evokes a need for more elaborate and comprehensive educational methods. Traditionally, learning comes from homework and problems worked out for students in class, or even after-school tutoring. Students now use educational programs such as WebWork, Mastering Physics, or WileyPLUS that apply the modern benefits of technology and cognitive science to education. These web-based tutoring systems allow students to work at their own pace and with feedback similar to that which would be received in class. This paper elucidates the efficacy of retesting and relearning on students who use a computer-based teaching system through the presentation of an experiment detailing their progress across a range of skills.

A number of studies have already shown that computer-based learning can be more effective than paper-and-pencil homework. One such report presents a reliable difference in the amount learned by eighth-grade students who did computer-based homework and received instant feedback and tutoring compared to control, where students got assessment the following day. (Singh, et al., 2010) The study indicates that improved learning comes from a combination of how soon students receive feedback and the quality of tutoring. Other research efforts help to differentiate between these two aspects of the learning process to identify how each affects it. A paper entitled “A preliminary look at timing of feedback in tutoring systems” describes how students who get delayed feedback take twice as long to complete the learning phase, although they could identify erroneous solution paths. (Lee, 1989) The same paper also indicates that immediate feedback can prevent students from learning incorrect rules by preempting false learning through correction. A similar study examines students who use computer-based learning with immediate feedback compared to students who use the same program and receive feedback the following day, simulating normal homework. The results show a statistically

significant difference in the amount gained by students in the experimental condition, indicating that instant assessment can be an aid in the learning process. (Pradhan, Saleem, Singh, & Heffernan, 2010) The effect the type and quality of tutoring has on the student is explored in another study wherein it is shown that students with high and low proficiency in math learn differently. Students with low proficiency learned more by working on problems one step at a time with assistance from interactive tutoring, whereas high proficiency learners gained more from being shown the entire solution. (Razzaq & Heffernan) This research is strongly related to the study presented here, in which the effect of retesting a student's knowledge over time is examined.

The experiment conducted here evaluates the ability of eighth-grade students to learn basic math skills customarily taught at their grade level. One group (experimental) is assigned problems for a particular skill and required to get three right in a row, or "master" the skill. They are then retested on the skill at 7, 14, 30, and 60 days where they are required to prove retention of the skill by getting three questions in a row correct in order to advance. When the student fails to retain mastery of the skill, they are required to relearn it before they can resume retesting. The system of retesting and relearning is known as ARRS (**A**utomatic **R**elearning and **R**eassessment **S**ystem) and is the basis of the experiment. The experimental group is compared to a control, which is required to attain mastery once but is never retested on the material. Student performance is evaluated at three separate times: a Pre-test to determine incoming knowledge, the learning phase over which students are taught and retested on material, and a Post-test to demonstrate what has been learned after the program. Ideally, it will be shown that the ARRS system benefits students' retention of mathematics skills by presenting statistically significant gain scores generated during the course of the program.

"Mastery learning" is of special importance to this project, a subject first proposed by cognitive scientist Benjamin Bloom. The central theme is that a student is required to master a subject before

being allowed to progress to a more difficult or unrelated topic. The definition of “mastery” generally varies, but for the purposes of this experiment it is defined as answering three questions in a row correctly, out of 10 randomly selected problems from a skill set. Mastery learning arises from Bloom’s now famous “2 Sigma Problem” in which he shows a two standard deviation improvement in students who receive one-on-one mastery tutoring. (Bloom, 1984) More recently, John Anderson has shown that mastery learning can lead to higher achievement across all students than traditional educational practices. (Anderson, 2000) While both of these studies show promising results with the use of mastery learning, both researchers agree that it may be difficult to implement in the classroom environment. Anderson notes that many schools have replaced mastery programs in favor of traditional practices because instructors cannot meet the level of commitment required and/or have difficulty managing each student individually. (Anderson, 2000) This issue is challenged by the ARRS program by incorporating mastery in a system that is simple to both administer and monitor.

Relearning and retesting are well established concepts in the field of education whose effectiveness has been demonstrated for years. A 1974 study shows the positive effect of mastery and relearning for students separated by aptitude. (Jones, 1974) Within each aptitude division (high, middle, low) students were divided into a mastery and non-mastery group. Non-mastery students were given a workbook with a test at the end of each chapter, and mastery students were given the same workbook with two tests. Mastery students were required to relearn the material if they failed the first test and then take the second test to ensure proficiency. The results of this study conclude that learning and retention of high and middle aptitude students is facilitated by mastery as a consequence of feedback and increased time spent learning, whereas low aptitude students show no significant improvement. Similar results will be presented in this experiment in that all students are expected to benefit to some degree from material that they are continually required to remaster. The incremental increase in time that the student is required to maintain mastered information is akin to any other exercise: gradual

growth permits students to build upon what they have and retrain what has been lost. The results will show the significant benefit of the ARRS system not only because of the integration of mastery with relearning/retesting but also the ease with which it is implemented in the classroom.

ASSISTments

The ASSISTments System is a web-based tutoring program for 4th to 10th grade mathematics, capable of tutoring students on problem sets while providing detailed evaluations of their performance to teachers. The word 'ASSISTments' blends 'assisting' (tutoring) students with 'assessment' (reporting) to teachers. The system offers teachers a range of reports that assess students' progress, including mastery status, assignment completion status, and proficiency, including warnings for students that are falling behind. Middle school and high school teachers in across the country are using the system as part of their coursework to assist students in learning mathematics while also providing teachers with the instant analyses that they could not perform on their own. As of 2009-2010, over 7,000 students are using the system. The system is free to use and funded by the US Department of Education and National Science Foundation CAREER grant.

One of the primary goals of the system is to efficiently tutor students using the process of formative assessment. Formative assessment informs both teachers and students about a student's understanding of a problem at a point when timely adjustments can be made. These adjustments help to ensure students achieve targeted standards-based learning goals within a set time frame. The assessment process is typically inefficient in practice because of the time it takes to address each student individually. ASSISTments solves this problem by tutoring students on items they get wrong, thus integrating a student's progress into their personalized curriculum. Then teachers can adjust their classroom instruction and pacing by using the detailed assessment data generated from the ASSISTments system.

Two different tutoring practices are implemented in ASSISTments to improve tutoring quality: giving hints and breaking harder problems into simpler ones. The latter method is called 'scaffolding', in which the system breaks the problem down to simpler parts when students enter incorrect solution

and asks the student to solve each sub-part of the problem. For the purposes of this study, scaffolding will not be considered and only problems utilizing hints will be included. The hint system gives students a series of suggestions that eventually state the answer outright. A student can no longer receive credit for a problem after they have used a hint.

While students can get instructional assistance in the form of scaffolding questions and hint messages, teachers can also get online, real-time reports on students' progress as students are using the system in the classroom. Proficiency reports shown in Figure 1 are one of the useful evaluations available to teachers to track students' progress. Each row reports information for a single student, including the number of problems they have done, the number of problems correct, and students' MCAS scores and performance level. In addition to the proficiency report, teachers can also use the Item/Mastery report as shown in Figure 2 to assess the amount of time a student spends on an assignment and their performance on scaffolding questions. For example, the fact that a student was consistently incorrect on a sub-part of a scaffolding question shows that the student failed to understand a particular concept related to that sub-part of the problem. In this way teachers can give unique attention to skills students struggle at all times without using class time to determine which students and in what skills.

Figure 1. Student proficiency report.

Student	Original questions					All questions			
	Done	Correct	Average	MCAS score	Perf. Level	Done	Correct	Average	Total hints
[REDACTED]	8	4	50%	NA	NA	8	4	50%	0
[REDACTED]	8	4	50%	NA	NA	8	4	50%	0
[REDACTED]	8	4	50%	NA	NA	8	4	50%	0

Figure 2. Item/Mastery report with problems seen and amount of time spent.

Student/Problem [Anonymize]	Average	Problems seen	Amount of Time	#119411 MainProblem:A Data driven	#119411 MainProblem:B Essay Grading	#119412 MainProblem:A Data driven	#119412 MainProblem:B Essay Grading
Problem average	100% Data driven			100%		100%	
Help requested percentage				0%		0%	
Common Wrong Answers							
	100%	8	00:12:40	3.5 	(Ungraded Essay) i gave them a 3.5 because they had two math vocabulary words but the answer was really short. the answer is just missing more work.	 4	(Ungraded Essay) i gave this a 4 because i see three math vocabulary words. and the words he/she put in the quotations help me understand what the "total" amount is.

This check mark indicates mastery status.

Experiment

This experiment analyzes what effect the ARRS program has on students' ability to retain mathematics skills by contrasting homework with relearning to that without it. The conditions that are compared are students who are required to master a particular skill at 7, 14, 30, and 60 days and the control group that is only required to master the skill initially. The results suggest that the ARRS program is generally beneficial for students across all skills after the 60 day learning period against control.

Setting and Participants

The study takes place in six eighth-grade math classrooms and at each student's home computer. The study involves a total of 138 suburban math students between all classes and their two teachers. One teacher instructed four classes (Teacher A) and the other the remaining two classes (Teacher B). The teachers had prior experience with the ASSISTments program at the beginning of the study and could help students with both technical and learning challenges.

Content

Assignments given to students typically involve on-grade-level skills, and occasionally prerequisite skills to ensure the students' ability. Skills are categorized as geometry, measurement, number sense, patterns, and algebra 1. The skills assigned to students are listed in Table 1, where certain skills are given a designation of "Pre" (Prerequisite) and "SIWS" (Say It With Symbols, or core skills at this education level for the unit students were studying at the start of the study).

Table 1. Assigned skills and prerequisite designation.

Skill	Placement in SIWS
Area of Circle	
Absolute Value	
Absolute Value – Addition & Subtraction	
Adding and Subtracting Fractions	
Addition - Decimals	
Area of Irregular Figure	Pre
Composition of Functions - and +	SIWS
Composition of Functions – Substitution	SIWS
Converting Decimals to Fractions	
Definition: Distributive, Associative, Commutative	SIWS
Discount and Sales Tax	
Distributive Property	Pre
Dividing Fractions	
Divisibility	
Equations from a Diagram	SIWS
Greatest Common Factor	
Least Common Multiple - In a Word Problem	
Least Common Multiple	
Multiplication and Division of Integers	Pre
Multiplication of Fractions	
Order of Operations - Basic	
Percent of	
Perimeter	Pre
Prime Factorization	
Recognizing Equivalent Expressions	SIWS
Scale Drawings	
Scientific Notation	
Solving Equations	Pre
Solving for Unknown Using Scale Factor	
Solving Variable Equation	Pre
Substitution	Pre
Writing Expressions from Situation	

Experimental Design

The experiment is designed such that each class of students is divided in half and randomly assigned to group A or B. Each of the 33 skills assigned during the learning phase is either “A ARRS” or “B ARRS,” indicating that the corresponding group receives the ARRS program for the skill. In this way the experiment is counterbalanced by the participation of each student in both the experimental and control group. Every student is required to master the skill within one week of its assignment. Mastery is achieved by answering three questions in a row correctly, out of ten. Students who have the ARRS condition for a particular skill are retested on each of them at 7, 14, 30, and 60 days with the same skill set (without hints) and required to prove mastery again at each date. Failure to retain mastery during a retesting opportunity obligates students to obtain mastery again with the original skill set. Furthermore, similar skills are grouped together in the A or B group to show an enhanced progression with skills that relate to or build upon each other. The designation of each skill for A and B ARRS during the learning phase is tabulated in Table 2, along with reference numbers and the date assigned.

Table 2. Learning phase skill reference information (ASSISTment number, ARRS group, date assigned).

Skill Set	Post-Test Problem	Skill Name	Skill Group	Date Given
11899	B6	Multiplication and Division of Integers	B	9/17/2010
10762	A1	Area of Circle	A	9/17/2010
10763	A15	Area of Irregular Figure	A	9/17/2010
10766	A8	Perimeter	A	9/17/2010
10195	B15	Distributive Property	B	9/17/2010
8741	B7	Divisibility	B	9/24/2010
10265	A18, A19	Solving Equations	A	9/24/2010
8946	A17	Substitution	A	9/24/2010
5962	B12	Addition - Decimals	B	9/24/2010
6876	A6	Converting Decimals to Fractions	A	10/1/2010
13935	B4	Recognizing Equivalent Expressions	B	10/1/2010
6848	A11	Order of Operations - Basic	A	10/1/2010
13718	B5	Definition: Distributive, Associative, Commutative	B	10/1/2010
6921	B14	Greatest Common Factor	B	10/8/2010
14543	B2	Composition of Functions - and +	B	10/8/2010
6917	A4	Dividing Fractions	A	10/8/2010
11836	A13	Adding and Subtracting Fractions	A	10/8/2010
11829	A7	Multiplication of Fractions	A	10/8/2010
7196	B1	Least Common Multiple	B	10/15/2010
6854	A9	Absolute Value	A	10/15/2010
5959	A10	Absolute Value – Addition & Subtraction	A	10/15/2010
6057	B11	Percent of	B	10/15/2010
6851	A16	Discount and Sales Tax	A	10/22/2010
6895	A2, A3	Scale Drawings	A	10/22/2010
7179	B8	Least Common Multiple – In a Word Problem	B	10/22/2010
6928	B9	Prime Factorization	B	10/22/2010
11893	B16	Scientific Notation	B	10/22/2010
6915	A14	Solving for Unknown Using Scale Factor	A	10/29/2010
15456	A5	Solving Variable Equation	A	10/29/2010
15296	B3	Composition of Functions – Substitution	B	10/29/2010
15490	B13	Equations from a Diagram	B	10/29/2010
15675	B10	Writing Expressions from Situation	B	10/29/2010

Procedure

Students were first assigned problems on September 17th, given 5 problem sets per week for seven weeks. These problem sets are collated in Appendix A for reference. Problems are randomly selected from the problem set and students are required to get three correct in a row to master a skill. Students in the experimental ARRS grouping are given reassessments 7 days, 14 days, 1 month, and 2 months after the original mastery. After enough time has passed for students to take their reassessments, a Post-test is administered four months later (March 4-16) to measure retention of the skills. Two Post-tests, A and B, were assigned and are given in Appendix B. Finally students were asked to take a survey after the conclusion of the program (April 18-23) to assess their opinion of it.

Results

At the outset of the study the students included originally numbered 138: 73 in group A and 65 in group B. Of these, 35 were removed from the study for not completing either the Pre-test or the Post-test. Excluding these students, 103 took part in the study with 54 in group A and 49 in group B. It is possible to remove these students from the study because of the counter-balance of the two groups.

The results of the study show that students in both conditions made gains in their mathematical ability. Gain is calculated as a student's Post-test score for a skill less their Pre-test score on the same skill. The Pre-test is a pass/fail test of whether a student gets the first three problems right on their first attempt at a skill (values of 0 and 1). Comparing the gain scores shows a significant difference between a student's scores while using ARRS and not. Figure 3 gives the gain distribution across students for ARRS students, Non-ARRS students, and the class's average between both groups. It can be seen in the figure that on average students who used ARRS had higher gain scores and that the majority of students with negative gain were in the Non-ARRS condition. The average gain for students using ARRS for a skill is 2.56 out of 10, and only 1.95 for students not using ARRS. A paired T-test across student gain scores

yields a p-value of 0.00215 and an effect size of 0.35572. The 95% confidence interval for the effect size is ± 0.03375 . A summary of these results is presented in Table 3.

Figure 3. Gain distribution across students.

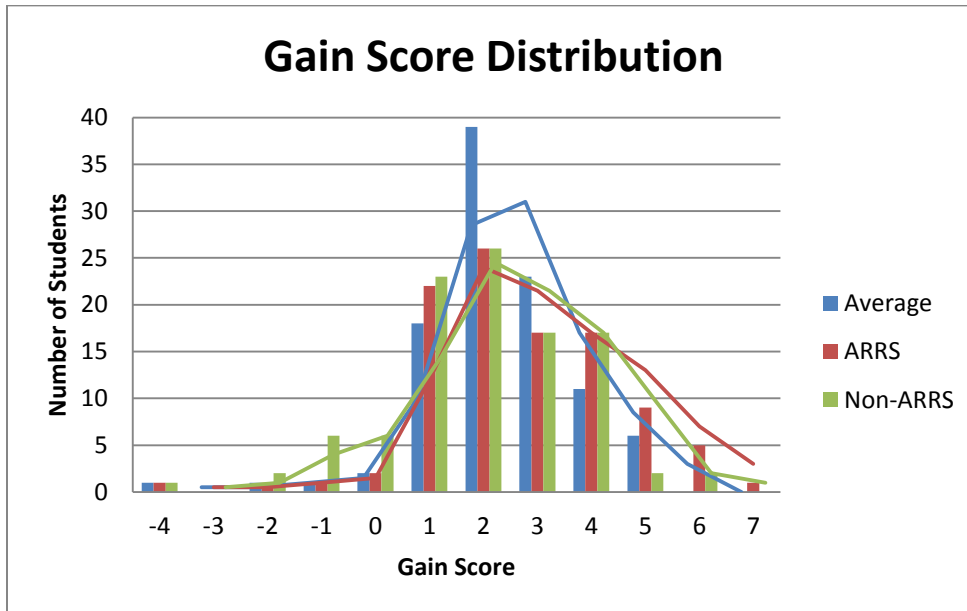

Table 3. Summary of data analyzed across students.

Group Statistics

Condition	Mean Gain	Std. Deviation
ARRS	2.56	0.172887
Non-ARRS	1.95	0.172029

T-test Data

t-value	Mean Difference	Std. Error Difference	σ (2-tail)	Effect Size	95% Confidence Interval Range for Effect Size	
2.55272	0.156214	0.024032	0.00215	0.35572	0.32197	0.38947

The same data can also be analyzed across the different skills. Gain scores for each skill are averaged for both ARRS and non-ARRS groups and a T-test is performed to verify the difference between them. The outcome is a p-value of 0.00969 and a corresponding effect size of 0.39673. The effect size

has a 95% confidence interval of ± 0.05196 . Mean gain scores are calculated for the ARRS and non-ARRS groupings to be 2.57 and 1.96 out of 10, respectively. The data across skills is summarized in Table 4.

Table 4. Summary of data analyzed across skills.

Group Statistics

Condition	Mean Gain	Std. Deviation
ARRS	2.57	0.150206
Non-ARRS	1.96	0.159564

T-test Data

t-value	Mean Difference	Std. Error Difference	σ (2-tail)	Effect Size	95% Confidence Interval Range for Effect Size	
1.64682	0.100	0.037041	0.00969	0.39673	0.34477	0.44869

The statistical measures can be used to prove certain points with the data. The purpose of the t-test is to prove that two data sets are reliably different, and the value of sigma is the probability that the two sets would randomly be the same. Therefore, low p-values (generally less than 0.05) suggest that it is highly unlikely that ARRS students did better than control by chance and indicates that the ARRS program has reliably benefited them. The effect size is a measure of the average student's improvement, in standard deviations, on the Post-test relative to the Pre-test. The confidence interval reaffirms the magnitude of the effect size, implying that 95% of students have an improvement within the given range.

It is important to show directly the effect the ARRS program has on a student's ability to retain information over time. This is accomplished by showing the percent retention of a skill at the Pre-test, 7, 14, and 30 day reassessment in Figure 4. Each colored bar corresponds to an assessment: Pre-test (blue), 7 day (red), 14 day (green), 30 day (purple). In most cases the Pre-test is the lowest and the general trend is to increase up to the assessment at 30 days, but there are also a number of skills in which retention leveled off or dropped by the 30 day reassessment.

Figure 4. Student retention of skills at Pre-test, 7, 14, and 30 day reassessment.

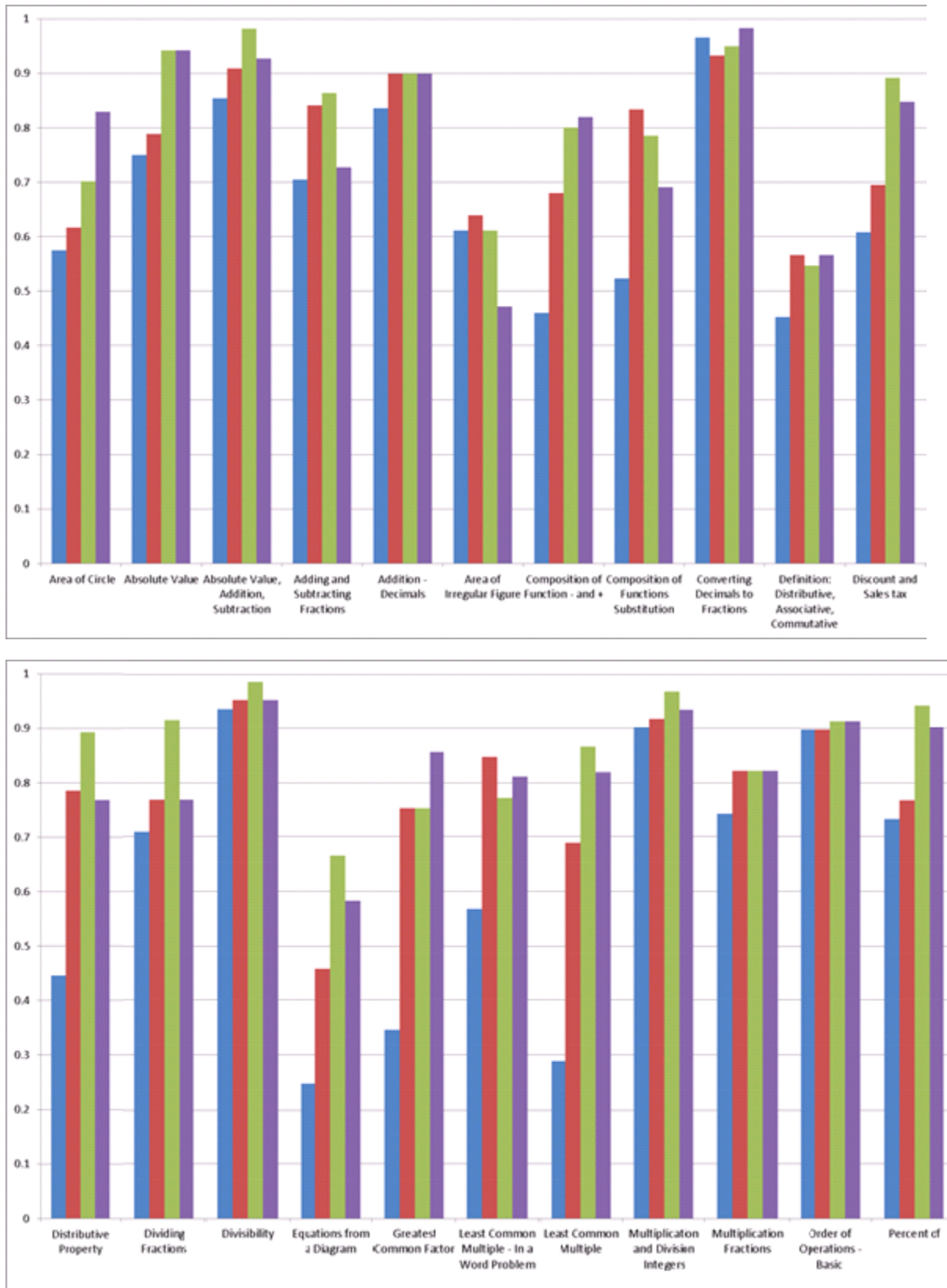

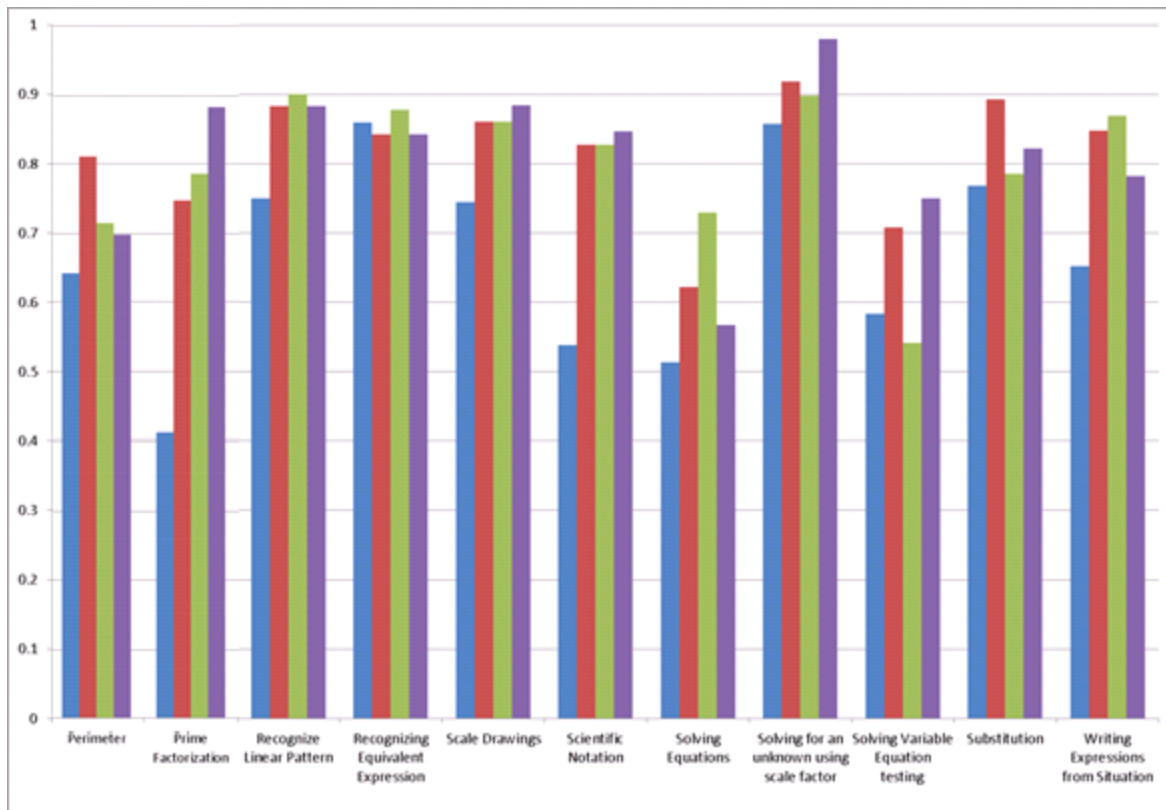

It should be considered that not all students are of the same aptitude, and that ARRS may not have the same effect on each student. In order to differentiate students by aptitude the retention over time is considered for three groups: those with a perfect score on the first attempt, those with a perfect score on the first reassessment (7 days), and the population average. It is assumed that a perfect score on one of the two attempts indicates that a student readily learned or relearned the skills and is of generally higher aptitude. This data is presented below, along with the corresponding data, in Figure 5 and Table 5. It is also relevant to perform a t-test to determine if the groups are reliably different for reassessments at 14 days and after. This analysis is presented in Table 6.

Figure 5. Student retention over time for high aptitude and average students.

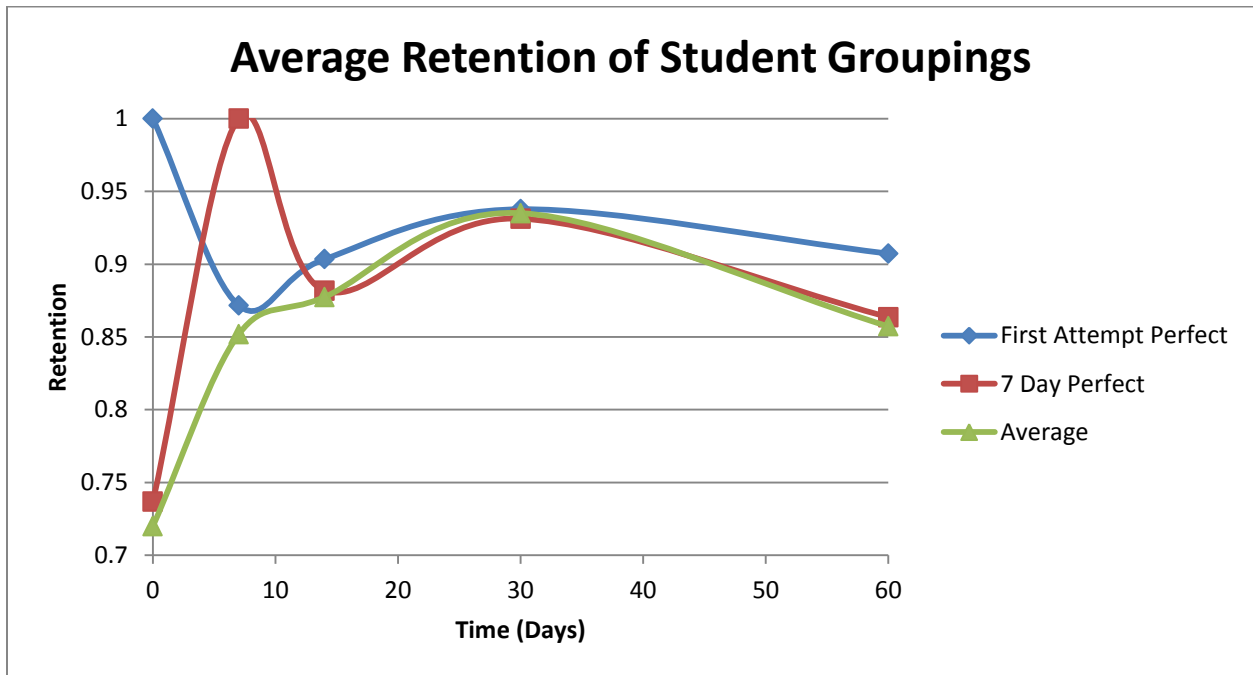

Table 5. Data for student retention over time.

Group	First Assessment	7 Days	14 Days	30 Days	60 Days
First Perfect	1	0.871664	0.903431	0.937738	0.907243
7 Day Perfect	0.736842	1	0.881847	0.931257	0.863588
Average	0.720036	0.851784	0.877402	0.935041	0.857274

Table 6. T-test data for student retention over time. ($\sigma > 0.1$, or not reliably different, in bold.)

First Attempt Perfect			7 Days Perfect			Average				
14 Days	30 Days	60 Days	14 Days	30 Days	60 Days	14 Days	30 Days	60 Days		
	0.031	0.227	0.019	0.074	0.001	0.004	0.025	3.E-4	14 Days	First Attempt Perfect
		0.002	0.001	0.256	1.E-6	2.E-4	0.904	1.E-7	30 Days	
			0.926	0.008	1.E-4	0.960	0.002	1.E-6	60 Days	
				0.002	0.030	0.841	5.E-4	0.010	14 Days	7 Days Perfect
					2.E-6	0.001	0.023	6.E-7	30 Days	
						0.027	5.E-7	0.063	60 Days	
							1.E-4	0.009	14 Days	Average
								1.E-7	30 Days	
									60 Days	

This data signifies a number of results that can be seen intuitively on the graph in Figure 5. The first item is that the original assumption is incorrect – getting a perfect score on a 7 day reassessment is not indicative of higher aptitude, only a perfect score on the first assessment is. The biggest consequence of the analysis is to notice the difference in retention at 60 days between average students and students with a perfect score on the first attempt: the difference is about 5% retention, or about half a letter grade better for high aptitude students. The drop in retention between 30 and 60 days in all groups is also of great importance, showing that all students, regardless of aptitude, are losing some skill retention within 30 days. Another notable feature that can be seen in the retention of high aptitude students is that retention has not changed significantly between 14 and 60 days and scores are not reliably different; although retention increases at 30 days, the students have retained the same amount at 14 days as they did at 60. This is not the case for the other groups as their retention has fallen significantly below their 14 day retention at 60 days. It is also interesting to note the convergence of all three lines at 30 days, indicating that aptitude may not play a part in how much the student can retain if given enough time. The retention can also be used as a probability of passing the following assessments: if a student has a perfect score on the first assessment, they have an 87.2% chance of passing the 7 day assessment. By the same logic a student has an 88.2% chance of passing the 14 day assessment with a perfect 7 day assessment.

Another interesting point can be noted when the data for skills that are not prerequisites or main skills is considered. These skills were most likely taught to students before the eighth grade and should be well known. The retention averaged across students at three reassessments for these skills is summarized in Table 7. A t-test is included to show a reliable difference between each assessment, and in this case a low p-value indicates that it is very likely that learning originated from the ARRS program. Student retention is shown in Figure 6 for these skills compared to average.

Table 7. Student retention of non-grade-level skills at three assessments.

	Pre-test	7 Day Reassessment	14 Day Reassessment	30 Day Reassessment	60 Day Reassessment
Average Retention	0.743711	0.883648	0.897799	0.955975	0.882075
T-test σ (2 tails)	2.93199×10^{-9}	0.351377	0.000101	3.35627×10^{-6}	

Figure 6. Student retention of non-core skills over time compared to average.

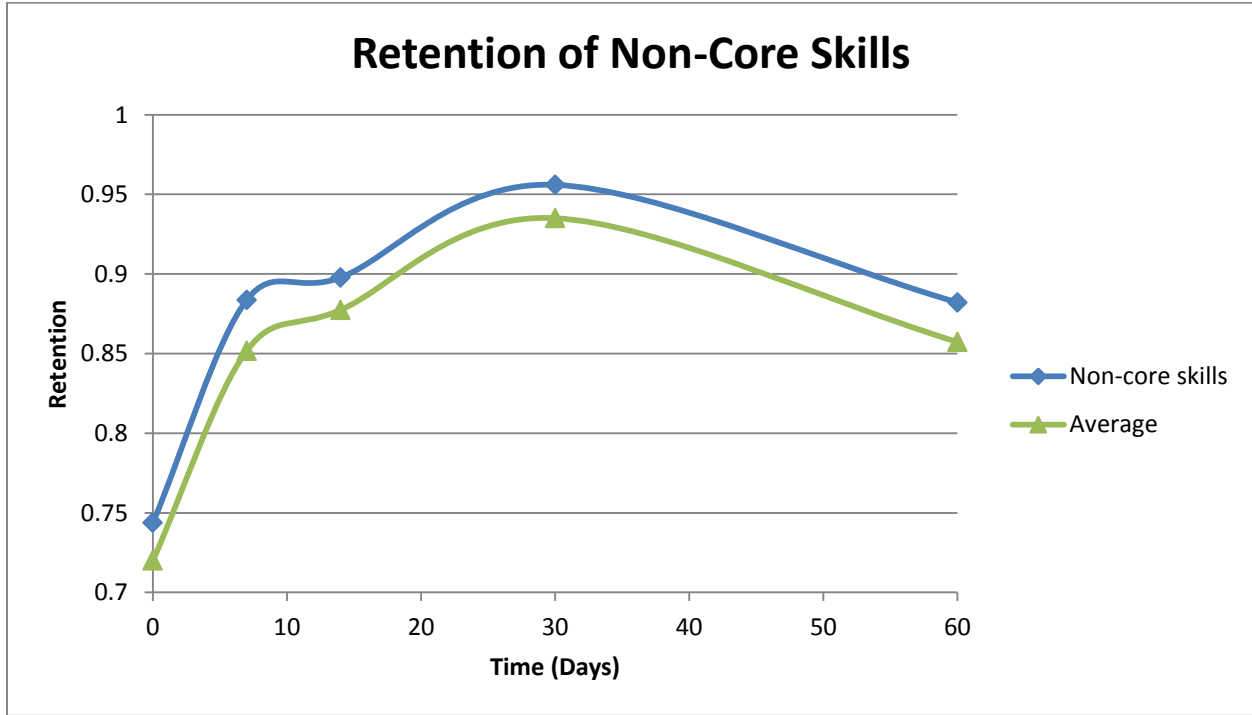

A survey asking students how they feel about ARRS was given out between April 18 and April 23. During the time, over 280 students from the middle school where the study took place responded to the survey. Answers to most of the survey questions are ‘opinion giving responses’ and ask students to select from Strongly Agree, Agree, Somewhat Agree, Somewhat Disagree, Disagree and Strongly Disagree. In order to calculate the average weight of a response, a digit value is given to each response where the value of 6 for ‘Strongly Agree’, 5 for ‘Agree’, 4 for ‘Somewhat Agree’, 3 for ‘Somewhat Disagree’, 2 for ‘Disagree’ and 1 for ‘Strongly Disagree’. A list of survey questions and the averaged response is given in Table 8, and a breakdown for question 7 in Table 9 and Figure 7.

Table 8. Average rating for survey questions. (Neutral = 3.5)

Question Number	Survey Question	Averaged Rating
1	The time I spent doing all the Skill Building and Reassessments and Relearning was TIME WELL SPENT.	3.535714
2	I like the challenge of working until I get three right in a row.	3.375451
3	I feel that once I get three right in a row I know the topic and do not need to get re-assessed a week later.	4.537634
4	I found that when I got a reassessment question wrong it was helpful to have to go back and practice a skill until I got three right in a row again.	3.036765
5	It was really hard to keep up with the Reassessment tests and all the relearning I had to do.	4.007273
6	Even though it takes more time, adding reassessment and relearning to my homework was beneficial.	3.440433
7	I feel as though the reassessment and retraining helped me retain the skills well into the year.	4.172662
8	How often during skill building did you need to ask a teacher for help in a week.	1.703571

Table 9. Responses to survey question 7. (Student retained the information into the year.)

Response	Ratings	Digit assigned to a rating	Multiplied value for rating
Disagree Strongly	25	1	25
Disagree	25	2	50
Disagree Somewhat	16	3	48
Agree Somewhat	57	4	228
Agree	121	5	605
Strongly Agree	34	6	204
Total	278	21	1160
Average			4.172662

Figure 7. Count of responses to question 7.

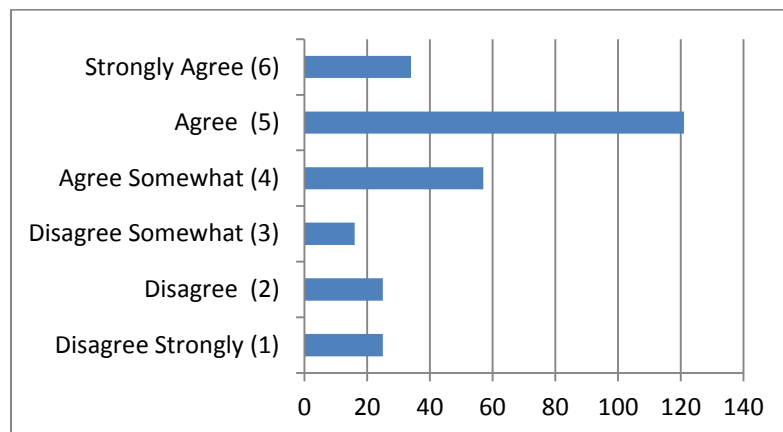

Since the value of average weighed response is 4.172662 in question 7, we can conclude that participants ‘somewhat agreed’ with the particular survey question that reassessment helped them retain information.

According to the average rating of the fourth survey question, we can see that students somewhat disagree that it is helpful to go back and practice a skill until they get three right in a row again. This seemingly contradicts the response to question 7, that they agree they are retaining it but do not believe it is helping them. The reason for this is that students in have difficulty getting three right in a row and that they find it hard to keep up with reassessment tests and relearning tasks as the results of other survey questions show. Another notable result is that students find the ASSISTments system’s tutoring system useful; most students rarely need help as indicated by Table 10 and Figure 8.

Table 10. Responses to survey question 8. (How often student got help.)

Frequency	Ratings	Value assigned to a rating	Multiplied value for rating
Never	140	1	140
1-2 times	97	2	194
3-5 times	29	3	87
More than 5 times	14	4	56
Total	280	10	477
Average			1.703571

Figure 8. Count of responses to survey question 8.

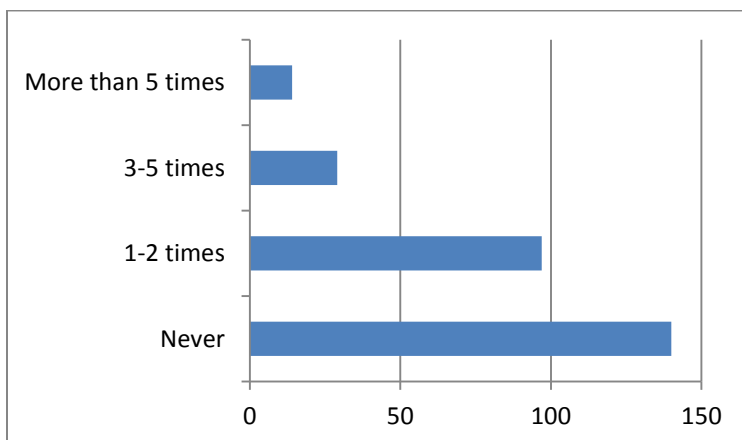

Discussion

The results show that students learned significantly more in the ARRS program. The ASSISTments website alone gave students an average gain of 1.95 without the ARRS program, and adding reassessments raises the gain to 2.56. The difference in gain corresponds to an effect size of 0.356 standard deviations gained per student. Other statistical analyses also confirm the accuracy of the figures presented. It is shown by the use of the t-test that there is a 99.8% chance that the improvement in gain scores is caused by use of the ARRS program. The confidence interval ensures that the effect produced by the program would be within 0.034 standard deviations of 0.356 for 95% of students. These analyses clearly demonstrate the positive effect of the use of the ARRS program for these students, and it will further be shown that the learning can have a lasting effect on ability.

The purpose of the ARRS program is to ensure that students retain the information learned, an effect which can be seen by consideration of assessment scores over time. Figures 4 and 5 indicate that students are undoubtedly learning while using ARRS and that maximum retention occurs around 30 days after the first assessment. Unfortunately the general trend is to lose progress between the 30 and 60 day assessments, where the average student loses 8.3% of the information retained over the 30 days. Comparatively, high aptitude students lose 3.3% of the information over the same course of time. The consequence of these trends is that the ARRS program is not significantly benefitting students when they do not receive reassessments often enough. The data show that when students are not refreshed on the material within 30 days their retention of it will drop. This result signifies that the spacing of reassessments could be adjusted to improve the learning experience for students.

High aptitude students are also a concern with respect to retention in that ARRS may not be benefitting them in the same way as other students. In Figure 5 it is shown that there is little change in retention between day 14 and day 60, indicating almost no benefit for these students. Like the average

students, those of high aptitude also fail to retain all of the information by day 60 so it is inconclusive whether or not ARRS is beneficial for these students. Further study will elucidate if it is better for high aptitude students to continue using ARRS or if proficiency and retention cannot improve significantly beyond 14 days. It is also important to determine if retention of both groups would continue to converge given more frequent assessments after 30 days. If this is the case it could be concluded that ARRS benefits students equally, given enough time, and that any student can attain the same aptitude level.

The different types of skills may also play a part in a student's ability to retain them. Some of the skills are considered "non-core" because they are not part of the eighth-grade curriculum, and it is expected that students will know these to some degree coming into the program. The diagram presented in Figure 6 shows that the average retention for non-core skills exceeds the average skills' by 2.0% on average (95% confidence $\pm 0.40\%$). Although this is not a very great increase, the analysis shows that students can retain these skills slightly better than core skills because of prior exposure to them. This same effect is noted in student responses to the survey given at the end of the study.

Student answers to the survey are polarized: a number of students enjoyed the ARRS program while others felt overwhelmed by either the workload or difficulty. An overwhelming number of students commented that using ASSISTments helped them to remember material from past years, a result predicted by the data. In response to the question "Should teachers do this again next year?" one student responded "I think the teachers should continue this experience for the incoming students. It helps us maintain our skills in the basics that we need to build off of to learn more advanced topics." Another student said, "I think that the reassessment test will help the students next year to review all of their topics throughout the year, which will help greatly for the MCAS because they will not forget the

material as easily.” Other students mentioned how applying themselves to the program brought out the best in their ability, like one student who commented glowingly:

“Yes, I think my teacher should do this again next year. I think this because they really did help me out as I did my reassessment test and relearned the skills. It really was for our benefit and doing these little things was a good way to remember them. Now when I do some of these things I know the answers right away. Even though it might be a little bit extra work, in the end it really does benefit the student.”

In contrast, a number of students were understandably frustrated by the extra work because the ARRS program was assigned in addition to their regular classwork. It is not surprising that some students would respond negatively to, as an article in TIME magazine refers to mathematics, “the least popular subject in the curriculum.” (Education: Least Popular Subject) Therefore, it is an overall excellent result to see so many students responding well to the program in addition to excelling.

The benefit that the program has had is exemplified in the case of certain students who applied themselves to taking up the material. One student was extatic in his response to the survey question (Should ARRS be used again?) and exclaimed, “Yes! It was helpful in my undersanding in these concepts, so yes yes yes!” This student’s gain scores correspond to his answer: 0.235 in ARRS and -0.125 in non-ARRS (average: 0.256 & 0.195, respectively). The negative gain score in the non-ARRS group indicates that the student may be struggling with math, but can attain nearly average comprehension by using ARRS. This is an exciting case; it is students like this who motivate themselves to learn that ARRS is being developed for. Another student is benefitted by the ARRS program without even realizing it, stating, “You should just do this if a child does not get the math at all and if they don’t get it then assign them maybe a daily skill type idea and give them that every week until they get three in a row,” implying that they knew the material well enough and ARRS was not a benefit to them. In reality, this student had a huge improvement in ability (Gain: 0.563 ARRS, 0.059 non-ARRS) and most likely retained a lot of

information from reassessments while feeling hassled by the extra work. Many other students have similar stories, benefitting from the program despite a general aversion of mathematics.

Conclusion

The results of the study lead to a single logical conclusion: ARRS is a powerful tool for educating students in math with little instructor involvement. It has been proven repeatedly through the positive results of the study that ARRS improves a student's ability over mastery alone. The primary statistical results of the study prove with 99.8% likelihood that students gained more than control using ARRS and subsequent analyses have investigated the nature and quality of this learning. ARRS provides students with a means of learning quality information at their own pace, permitting motivated students of any aptitude level to improve. By these efficacious results it can be claimed that ARRS is as effective as one-on-one tutoring when students apply themselves to the work.

The biggest problem with using ARRS is readily apparent when viewing average student retention over time. The characteristic curve shows students increasing in knowledge up to day 30 when retention reaches a maximum, before falling by 8% on average by day 60. It is logical to conclude from this that 30 days is too long an interval for students to retain the information without losing some of it. Consequently, it is recommended for other studies to investigate what factors affect how long a student can retain information for and what a better reassessment schedule would be to both improve the amount retained and increase retention duration. The study could accomplish this by retesting a number of experimental groups that have reassessments 1 week, 2 weeks, and 3 weeks after the 30 day assessment to determine an optimal schedule to improve retention. It should also be determined what effect extending the reassessment period has and whether it can increase the peak retention or the amount of time it is retained. For obvious reasons 100% of information cannot be retained indefinitely, so an acceptable level given the amount of student time put in should be determined.

Another notable fact that arises from the data presented in the study is that students do not all learn in the same way. While some students are motivated and will work for an hour or more to learn a

difficult skill, others might get frustrated and give up immediately; a student who is predisposed to mathematical ability will learn the information more quickly and retain it longer than a student with little intrinsic skill. Although not the focus of this study, some relevant information has been shown indicating that high aptitude students will retain more information than the average grouping over the same amount of time. Csikszentmihalyi notes a similar effect in “Flow: The Psychology of Optimal Experience,” stating that a student’s response to a problem is a consequence of their ability and the problem’s difficulty. (Csikszentmihalyi, 1991) The mental state that is evoked in a student by the problem difficulty and their intelligence as suggested by Csikszentmihalyi is diagrammed in Figure 9.

Figure 9. Student mental state given by intelligence and challenge.

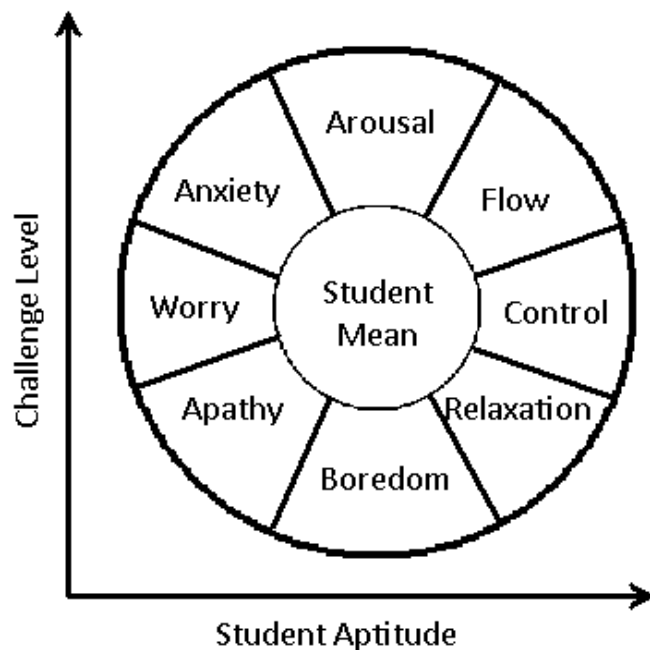

The ideal state of “flow” is one of intense focus and motivation during which optimal learning is achieved. Assimilating a system into ASSISTments that continually evaluates students on their aptitude and assigns problems of corresponding difficulty will tailor the ARRS experience to the individual student. Personalizing the system will make it applicable to a wider range of students while also targeting the optimal state of learning. In this way, students of lower aptitude can progress slowly yet

effectively and students of higher aptitude can excel even further. Another difference in students of high aptitude is that they may not need to be reassessed for as long as other students. It is recommended for future studies that the effect of removing an experimental group from ARRS early (after 14 day reassessment) be investigated, to see how high aptitude students with less reassessments compare on a post-test to other students. Minimizing the amount of time spent on ARRS (while still prioritizing retention) will further improve an already beneficial program.

It has been repeatedly demonstrated throughout this study that ARRS will improve the mathematical ability of students, especially those who self-motivate to learn from the material. A system that verifies that a student has a minimal proficiency in a skill and reteaches it to them otherwise is the ideal means of educating a student because it simulates one-on-one tutoring without the expense of a 1:1 teacher to student ratio. This system is constantly evolving to meet the growing needs of a diverse student population; being fine tuned to develop the optimal means of communicating mathematics. This is a complex issue, bringing together cognitive psychology, education, and modern technology in what will ultimately shape the future. Tomorrow's leaders are today's students, and providing them the opportunity to understand math with ASSISTments advances not just the individual, but the world as a whole.

Acknowledgements

Our grateful thanks go to primary sponsors of ASSISTments, the **U.S. Department of Education** (Grant #R305K03140, #R305A07440 and the National Math Center grant #R305C100024) and the **National Science Foundation** (Grant #0231773 and CAREER Grant #REC-0448319 and a GK12 grant #0742503). We also would like to acknowledge **The Spencer Foundation, the United States Army, the GE Foundation, and the Office of Naval Research**(Grant #N00014-03-1-0221) for their additional funding and Amazon web services for free computing resources.

We also greatly appreciate the efforts of the students and teachers using our program without whom this project could not exist. Finally, we want to give special thanks to our advisors, Cristina Heffernan and Neil Heffernan for guiding us throughout our project as well as Matthew Dailey and Yutao Wang from the ASSISTments team for helping us to extract useful data from the ASSISTments system.

References

- Education: Least Popular Subject. (1956, June 18). *TIME Magazine*.
- Anderson, J. R. (2000). *Learning and Memory: An Integrated Approach*. John Wiley & Sons, Inc.
- Bloom, B. S. (1984). The Two Sigma Problem: The Search for Methods of Group Instruction as Effective as One-to-One Tutoring. *Educational Researcher*, 4-16.
- Csikszentmihalyi, M. (1991). *Flow: The Psychology of Optimal Experience*. New York: Harper Perennial.
- Jones, F. G. (1974). *The Effects of Mastery and Aptitude on Learning, Retention, and Time*.
- Lee, A. Y. (1989). *A preliminary look at timing of feedback in tutoring systems*.
- Pradhan, P., Saleem, M. B., Singh, R., & Heffernan, N. (2010). *An In-Depth Analysis of Tutoring Strategies in ASSISTments*. Worcester: Worcester Polytechnic Institute.
- Razzaq, L., & Heffernan, N. (n.d.). Tutored problem solving: An effective strategy or a waste of time? *Journal of Educational Psychology*.
- Singh, R., Saleem, M. B., Pradhan, P. R., Heffernan, C., Heffernan, N. T., Razzaq, L., et al. (2010). Students Learn More with Computer-Supported Homework. *Computers and Education*.

Appendix A: Problem Sets for Mastery

Distributive Property (10195)	35
Multiplication and Division of Integers (11899)	69
Perimeter (10766).....	81
Area of Circle (10762)	122
Area of Irregular Figure (10763)	156
Solving Equations (10265).....	195
Addition of Decimals (5962)	210
Substitution (8946)	214
Recognizing Linear Patterns (8752)	228
Divisibility (8741).....	268
Recognizing Equivalent Expressions (13935)	283
Order of Operations (6848)	307
Definition: Distributive, Associative, Commutative (13718)	319
Converting Decimals to Fractions (6876).....	373
Composition of Functions - and + (14543)	387
Adding and Subtracting Fractions (11836)	413
Multiplying Fractions (11829)	432
Dividing Fractions (6917)	444
Greatest Common Factor (6921)	463
Absolute Value (6854).....	474
Absolute Value: Addition & Subtraction (5959)	494
Percent of (6057)	503
Least Common Multiple (7196)	506
Composition of Functions - Substitution (15296).....	511
Equations from a Diagram (15490).....	532
Writing Expressions from Situation (15675).....	585
Solving Variable Equation (15456).....	599
Scale Factor (6915).....	619
Discount and Sales Tax (6851)	646
Scale Drawings (6895).....	660
Least Common Multiple – In a Word Problem (7179).....	675
Prime Factorization (6928).....	682
Scientific Notation (11893)	697

Appendix B: Post-tests

Post-test A..... 716
Post-test B..... 720

Problem Set %\$%) "Distributive Property - THE SKILL BUILDING SET" id:[10195]

1) Assistent #85471 "85471 - Use the distribut..."

Use the distributive property to multiply.
 $23(13m-5)$

Type your answers without any spaces and in standard form.
Standard Form: $3x-2y+z+5$. Make sure to write $3+-5$ as $3-5$.

2) Assistent #85472 "85472 - Use the distribut..."

Use the distributive property to multiply.
 $22(25m-10)$

Type your answers without any spaces and in standard form.
Standard Form: $3x-2y+z+5$. Make sure to write $3+-5$ as $3-5$.

3) Assistent #85473 "85473 - Use the distribut..."

Use the distributive property to multiply.
 $7(25m-7)$

Type your answers without any spaces and in standard form.
Standard Form: $3x-2y+z+5$. Make sure to write $3+-5$ as $3-5$.

4) Assistent #85474 "85474 - Use the distribut..."

Use the distributive property to multiply.
 $19(20m-18)$

Type your answers without any spaces and in standard form.
Standard Form: $3x-2y+z+5$. Make sure to write $3+-5$ as $3-5$.

5) Assistent #85475 "85475 - Use the distribut..."

Use the distributive property to multiply.
 $21(18m-20)$

Type your answers without any spaces and in standard form.
Standard Form: $3x-2y+z+5$. Make sure to write $3+-5$ as $3-5$.

6) Assistent #85476 "85476 - Use the distribut..."

Use the distributive property to multiply.
 $21(10m-16)$

Type your answers without any spaces and in standard form.
Standard Form: $3x-2y+z+5$. Make sure to write $3+-5$ as $3-5$.

7) Assistent #85477 "85477 - Use the distribut..."

Use the distributive property to multiply.
 $30(11m-19)$

Type your answers without any spaces and in standard form.
Standard Form: $3x-2y+z+5$. Make sure to write $3+-5$ as $3-5$.

8) Assistent #85478 "85478 - Use the distribut..."

Use the distributive property to multiply.
 $16(7m-13)$

Type your answers without any spaces and in standard form.
Standard Form: $3x-2y+z+5$. Make sure to write $3+-5$ as $3-5$.

9) Assistent #85479 "85479 - Use the distribut..."

Use the distributive property to multiply.
 $2(6m-6)$

Type your answers without any spaces and in standard form.
Standard Form: $3x-2y+z+5$. Make sure to write $3+-5$ as $3-5$.

10) Assistent #85480 "85480 - Use the distribut..."

Use the distributive property to multiply.
 $28(9m-2)$

Type your answers without any spaces and in standard form.
Standard Form: $3x-2y+z+5$. Make sure to write $3+-5$ as $3-5$.

11) Assistent #85481 "85481 - Use the distribut..."

Use the distributive property to multiply.
 $2(23m-22)$

Type your answers without any spaces and in standard form.
Standard Form: $3x-2y+z+5$. Make sure to write $3+-5$ as $3-5$.

12) Assistent #85482 "85482 - Use the distribut..."

Use the distributive property to multiply.
 $7(12m-12)$

Type your answers without any spaces and in standard form.
Standard Form: $3x-2y+z+5$. Make sure to write $3+-5$ as $3-5$.

13) Assistent #85483 "85483 - Use the distribut..."

Use the distributive property to multiply.
 $27(28m-2)$

Type your answers without any spaces and in standard form.
Standard Form: $3x-2y+z+5$. Make sure to write $3+-5$ as $3-5$.

14) Assistent #85484 "85484 - Use the distribut..."

Use the distributive property to multiply.
 $5(15m-1)$

Type your answers without any spaces and in standard form.
Standard Form: $3x-2y+z+5$. Make sure to write $3+-5$ as $3-5$.

15) Assistent #85485 "85485 - Use the distribut..."

Use the distributive property to multiply.
 $18(11m-25)$

Type your answers without any spaces and in standard form.
Standard Form: $3x-2y+z+5$. Make sure to write $3+-5$ as $3-5$.

16) Assistent #85486 "85486 - Use the distribut..."

Use the distributive property to multiply.
 $26(16m-29)$

Type your answers without any spaces and in standard form.
Standard Form: $3x-2y+z+5$. Make sure to write $3+-5$ as $3-5$.

17) Assistent #85487 "85487 - Use the distribut..."

Use the distributive property to multiply.
 $30(11m-24)$

Type your answers without any spaces and in standard form.
Standard Form: $3x-2y+z+5$. Make sure to write $3+-5$ as $3-5$.

18) Assistent #85488 "85488 - Use the distribut..."

Use the distributive property to multiply.
 $24(20m-4)$

Type your answers without any spaces and in standard form.
Standard Form: $3x-2y+z+5$. Make sure to write $3+-5$ as $3-5$.

19) Assistent #85489 "85489 - Use the distribut..."

Use the distributive property to multiply.
 $13(12m-18)$

Type your answers without any spaces and in standard form.
Standard Form: $3x-2y+z+5$. Make sure to write $3+-5$ as $3-5$.

20) Assistent #85490 "85490 - Use the distribut..."

Use the distributive property to multiply.
 $15(11m-22)$

Type your answers without any spaces and in standard form.
Standard Form: $3x-2y+z+5$. Make sure to write $3+-5$ as $3-5$.

21) Assistent #85491 "85491 - Use the distribut..."

Use the distributive property to multiply.
 $6(6m+7)$

Type your answers without any spaces and in standard form.
Standard Form: $3x-2y+z+5$ Make sure to write $3+-5$ as $3-5$

22) Assistent #85492 "85492 - Use the distribut..."

Use the distributive property to multiply.
 $8(7m+6)$

Type your answers without any spaces and in standard form.
Standard Form: $3x-2y+z+5$ Make sure to write $3+-5$ as $3-5$

23) Assistent #85493 "85493 - Use the distribut..."

Use the distributive property to multiply.
 $1(1m+8)$

Type your answers without any spaces and in standard form.
Standard Form: $3x-2y+z+5$ Make sure to write $3+-5$ as $3-5$

24) Assistent #85494 "85494 - Use the distribut..."

Use the distributive property to multiply.
 $5(4m+4)$

Type your answers without any spaces and in standard form.
Standard Form: $3x-2y+z+5$ Make sure to write $3+-5$ as $3-5$

25) Assistent #85495 "85495 - Use the distribut..."

Use the distributive property to multiply.
 $8(8m+6)$

Type your answers without any spaces and in standard form.
Standard Form: $3x-2y+z+5$ Make sure to write $3+-5$ as $3-5$

26) Assistent #85496 "85496 - Use the distribut..."

Use the distributive property to multiply.
 $6(1m+9)$

Type your answers without any spaces and in standard form.
Standard Form: $3x-2y+z+5$ Make sure to write $3+-5$ as $3-5$

27) Assistent #85497 "85497 - Use the distribut..."

Use the distributive property to multiply.
 $1(4m+8)$

Type your answers without any spaces and in standard form.
Standard Form: $3x-2y+z+5$ Make sure to write $3+-5$ as $3-5$

28) Assistent #85498 "85498 - Use the distribut..."

Use the distributive property to multiply.

$$1(1m+4)$$

Type your answers without any spaces and in standard form.

Standard Form: $3x-2y+z+5$ Make sure to write $3+-5$ as $3-5$

29) Assistent #85499 "85499 - Use the distribut..."

Use the distributive property to multiply.

$$2(3m+8)$$

Type your answers without any spaces and in standard form.

Standard Form: $3x-2y+z+5$ Make sure to write $3+-5$ as $3-5$

30) Assistent #85500 "85500 - Use the distribut..."

Use the distributive property to multiply.

$$6(2m+8)$$

Type your answers without any spaces and in standard form.

Standard Form: $3x-2y+z+5$ Make sure to write $3+-5$ as $3-5$

31) Assistent #85501 "85501 - Use the distribut..."

Use the distributive property to multiply.

$$7(3m+9)$$

Type your answers without any spaces and in standard form.

Standard Form: $3x-2y+z+5$ Make sure to write $3+-5$ as $3-5$

32) Assistent #85502 "85502 - Use the distribut..."

Use the distributive property to multiply.

$$4(7m+2)$$

Type your answers without any spaces and in standard form.

Standard Form: $3x-2y+z+5$ Make sure to write $3+-5$ as $3-5$

33) Assistent #85503 "85503 - Use the distribut..."

Use the distributive property to multiply.

$$4(2m+2)$$

Type your answers without any spaces and in standard form.

Standard Form: $3x-2y+z+5$ Make sure to write $3+-5$ as $3-5$

34) Assistent #85504 "85504 - Use the distribut..."

Use the distributive property to multiply.
 $1(4m+10)$

Type your answers without any spaces and in standard form.
Standard Form: $3x-2y+z+5$ Make sure to write $3+-5$ as $3-5$

35) Assistent #85505 "85505 - Use the distribut..."

Use the distributive property to multiply.
 $10(6m+10)$

Type your answers without any spaces and in standard form.
Standard Form: $3x-2y+z+5$ Make sure to write $3+-5$ as $3-5$

36) Assistent #85506 "85506 - Use the distribut..."

Use the distributive property to multiply.
 $3(9m+10)$

Type your answers without any spaces and in standard form.
Standard Form: $3x-2y+z+5$ Make sure to write $3+-5$ as $3-5$

37) Assistent #85507 "85507 - Use the distribut..."

Use the distributive property to multiply.
 $3(3m+7)$

Type your answers without any spaces and in standard form.
Standard Form: $3x-2y+z+5$ Make sure to write $3+-5$ as $3-5$

38) Assistent #85508 "85508 - Use the distribut..."

Use the distributive property to multiply.
 $5(4m+7)$

Type your answers without any spaces and in standard form.
Standard Form: $3x-2y+z+5$ Make sure to write $3+-5$ as $3-5$

39) Assistent #85509 "85509 - Use the distribut..."

Use the distributive property to multiply.
 $9(2m+2)$

Type your answers without any spaces and in standard form.
Standard Form: $3x-2y+z+5$ Make sure to write $3+-5$ as $3-5$

40) Assistent #85510 "85510 - Use the distribut..."

Use the distributive property to multiply.
 $6(2m+1)$

Type your answers without any spaces and in standard form.
Standard Form: $3x-2y+z+5$ Make sure to write $3+-5$ as $3-5$

41) Assistent #85511 "85511 - Use the distribut..."

Use the distributive property to multiply.
 $4(-5m+1)$

Type your answers without any spaces and in standard form.
Standard Form: $3x-2y+z+5$. Make sure to write $3+-5$ as $3-5$.

42) Assistent #85512 "85512 - Use the distribut..."

Use the distributive property to multiply.
 $4(-2m+7)$

Type your answers without any spaces and in standard form.
Standard Form: $3x-2y+z+5$. Make sure to write $3+-5$ as $3-5$.

43) Assistent #85513 "85513 - Use the distribut..."

Use the distributive property to multiply.
 $1(-5m+7)$

Type your answers without any spaces and in standard form.
Standard Form: $3x-2y+z+5$. Make sure to write $3+-5$ as $3-5$.

44) Assistent #85514 "85514 - Use the distribut..."

Use the distributive property to multiply.
 $8(-7m+1)$

Type your answers without any spaces and in standard form.
Standard Form: $3x-2y+z+5$. Make sure to write $3+-5$ as $3-5$.

45) Assistent #85515 "85515 - Use the distribut..."

Use the distributive property to multiply.

$$10(-7m+4)$$

Type your answers without any spaces and in standard form.

Standard Form: $3x-2y+z+5$. Make sure to write $3+-5$ as $3-5$.

46) Assistent #85516 "85516 - Use the distribut..."

Use the distributive property to multiply.

$$4(-1m+5)$$

Type your answers without any spaces and in standard form.

Standard Form: $3x-2y+z+5$. Make sure to write $3+-5$ as $3-5$.

47) Assistent #85517 "85517 - Use the distribut..."

Use the distributive property to multiply.

$$10(-8m+3)$$

Type your answers without any spaces and in standard form.

Standard Form: $3x-2y+z+5$. Make sure to write $3+-5$ as $3-5$.

48) Assistent #85518 "85518 - Use the distribut..."

Use the distributive property to multiply.

$$1(-10m+3)$$

Type your answers without any spaces and in standard form.

Standard Form: $3x-2y+z+5$. Make sure to write $3+-5$ as $3-5$.

49) Assistent #85519 "85519 - Use the distribut..."

Use the distributive property to multiply.

$$1(-10m+10)$$

Type your answers without any spaces and in standard form.

Standard Form: $3x-2y+z+5$. Make sure to write $3+-5$ as $3-5$.

50) Assistent #85520 "85520 - Use the distribut..."

Use the distributive property to multiply.

$$2(-5m+6)$$

Type your answers without any spaces and in standard form.

Standard Form: $3x-2y+z+5$. Make sure to write $3+-5$ as $3-5$.

51) Assistent #85521 "85521 - Use the distribut..."

Use the distributive property to multiply.
 $8(-9m+2)$

Type your answers without any spaces and in standard form.
Standard Form: $3x-2y+z+5$. Make sure to write $3+-5$ as $3-5$.

52) Assistent #85522 "85522 - Use the distribut..."

Use the distributive property to multiply.
 $3(-2m+7)$

Type your answers without any spaces and in standard form.
Standard Form: $3x-2y+z+5$. Make sure to write $3+-5$ as $3-5$.

53) Assistent #85523 "85523 - Use the distribut..."

Use the distributive property to multiply.
 $6(-8m+5)$

Type your answers without any spaces and in standard form.
Standard Form: $3x-2y+z+5$. Make sure to write $3+-5$ as $3-5$.

54) Assistent #85524 "85524 - Use the distribut..."

Use the distributive property to multiply.
 $2(-3m+8)$

Type your answers without any spaces and in standard form.
Standard Form: $3x-2y+z+5$. Make sure to write $3+-5$ as $3-5$.

55) Assistent #85525 "85525 - Use the distribut..."

Use the distributive property to multiply.
 $5(-8m+2)$

Type your answers without any spaces and in standard form.
Standard Form: $3x-2y+z+5$. Make sure to write $3+-5$ as $3-5$.

56) Assistent #85526 "85526 - Use the distribut..."

Use the distributive property to multiply.
 $6(-1m+8)$

Type your answers without any spaces and in standard form.
Standard Form: $3x-2y+z+5$. Make sure to write $3+-5$ as $3-5$.

57) Assistent #85527 "85527 - Use the distribut..."

Use the distributive property to multiply.
 $5(-6m+1)$

Type your answers without any spaces and in standard form.
Standard Form: $3x-2y+z+5$. Make sure to write $3+-5$ as $3-5$.

58) Assistent #85528 "85528 - Use the distribut..."

Use the distributive property to multiply.
 $8(-4m+5)$

Type your answers without any spaces and in standard form.
Standard Form: $3x-2y+z+5$. Make sure to write $3+-5$ as $3-5$.

59) Assistent #85529 "85529 - Use the distribut..."

Use the distributive property to multiply.
 $10(-4m+1)$

Type your answers without any spaces and in standard form.
Standard Form: $3x-2y+z+5$. Make sure to write $3+-5$ as $3-5$.

60) Assistent #85530 "85530 - Use the distribut..."

Use the distributive property to multiply.
 $9(-4m+7)$

Type your answers without any spaces and in standard form.
Standard Form: $3x-2y+z+5$. Make sure to write $3+-5$ as $3-5$.

61) Assistent #85531 "85531 - Use the distribut..."

Use the distributive property to multiply.
 $4(-2m-3)$

Type your answers without any spaces and in standard form.
Standard Form: $3x-2y+z+5$. Make sure to write $3+-5$ as $3-5$.

62) Assistent #85532 "85532 - Use the distribut..."

Use the distributive property to multiply.
 $7(-6m-5)$

Type your answers without any spaces and in standard form.
Standard Form: $3x-2y+z+5$. Make sure to write $3+-5$ as $3-5$.

63) Assistent #85533 "85533 - Use the distribut..."

Use the distributive property to multiply.
 $3(-7m-4)$

Type your answers without any spaces and in standard form.
Standard Form: $3x-2y+z+5$. Make sure to write $3+-5$ as $3-5$.

64) Assistent #85534 "85534 - Use the distribut..."

Use the distributive property to multiply.
 $1(-1m-8)$

Type your answers without any spaces and in standard form.
Standard Form: $3x-2y+z+5$. Make sure to write $3+-5$ as $3-5$.

65) Assistent #85535 "85535 - Use the distribut..."

Use the distributive property to multiply.
 $8(-2m-10)$

Type your answers without any spaces and in standard form.
Standard Form: $3x-2y+z+5$. Make sure to write $3+-5$ as $3-5$.

66) Assistent #85536 "85536 - Use the distribut..."

Use the distributive property to multiply.
 $9(-7m-7)$

Type your answers without any spaces and in standard form.
Standard Form: $3x-2y+z+5$. Make sure to write $3+-5$ as $3-5$.

67) Assistent #85537 "85537 - Use the distribut..."

Use the distributive property to multiply.
 $6(-7m-5)$

Type your answers without any spaces and in standard form.
Standard Form: $3x-2y+z+5$. Make sure to write $3+-5$ as $3-5$.

68) Assistent #85538 "85538 - Use the distribut..."

Use the distributive property to multiply.
 $9(-3m-9)$

Type your answers without any spaces and in standard form.
Standard Form: $3x-2y+z+5$. Make sure to write $3+-5$ as $3-5$.

69) Assistent #85539 "85539 - Use the distribut..."

Use the distributive property to multiply.
 $6(-7m-6)$

Type your answers without any spaces and in standard form.
Standard Form: $3x-2y+z+5$. Make sure to write $3+-5$ as $3-5$.

70) Assistent #85541 "85541 - Use the distribut..."

Use the distributive property to multiply.
 $7(-3m-6)$

Type your answers without any spaces and in standard form.
Standard Form: $3x-2y+z+5$. Make sure to write $3+-5$ as $3-5$.

71) Assistent #85542 "85542 - Use the distribut..."

Use the distributive property to multiply.
 $4(-10m-7)$

Type your answers without any spaces and in standard form.
Standard Form: $3x-2y+z+5$. Make sure to write $3+-5$ as $3-5$.

72) Assistent #85543 "85543 - Use the distribut..."

Use the distributive property to multiply.
 $10(-8m-1)$

Type your answers without any spaces and in standard form.
Standard Form: $3x-2y+z+5$. Make sure to write $3+-5$ as $3-5$.

73) Assistent #85544 "85544 - Use the distribut..."

Use the distributive property to multiply.
 $9(-6m-3)$

Type your answers without any spaces and in standard form.
Standard Form: $3x-2y+z+5$. Make sure to write $3+-5$ as $3-5$.

74) Assisment #85545 "85545 - Use the distribut..."

Use the distributive property to multiply.
 $7(-8m-7)$

Type your answers without any spaces and in standard form.
Standard Form: $3x-2y+z+5$. Make sure to write $3+-5$ as $3-5$.

75) Assisment #85546 "85546 - Use the distribut..."

Use the distributive property to multiply.
 $3(-8m-7)$

Type your answers without any spaces and in standard form.
Standard Form: $3x-2y+z+5$. Make sure to write $3+-5$ as $3-5$.

76) Assisment #85547 "85547 - Use the distribut..."

Use the distributive property to multiply.
 $4(-7m-7)$

Type your answers without any spaces and in standard form.
Standard Form: $3x-2y+z+5$. Make sure to write $3+-5$ as $3-5$.

77) Assisment #85548 "85548 - Use the distribut..."

Use the distributive property to multiply.
 $10(-3m-2)$

Type your answers without any spaces and in standard form.
Standard Form: $3x-2y+z+5$. Make sure to write $3+-5$ as $3-5$.

78) Assisment #85549 "85549 - Use the distribut..."

Use the distributive property to multiply.
 $5(-7m-6)$

Type your answers without any spaces and in standard form.
Standard Form: $3x-2y+z+5$. Make sure to write $3+-5$ as $3-5$.

79) Assistent #85550 "85550 - Use the distribut..."

Use the distributive property to multiply.

$$3(-1m-9)$$

Type your answers without any spaces and in standard form.
Standard Form: $3x-2y+z+5$. Make sure to write $3+-5$ as $3-5$.

80) Assistent #85551 "85551 - Use the distribut..."

Use the distributive property to multiply.

$$2(-9m-10)$$

Type your answers without any spaces and in standard form.
Standard Form: $3x-2y+z+5$. Make sure to write $3+-5$ as $3-5$.

81) Assistent #85552 "85552 - Use the distribut..."

Use the distributive property to multiply.

$$-2(-7m-5)$$

Type your answers without any spaces and in standard form.
Standard Form: $3x-5y+z+5$. Make sure to write $3+-5$ as $3-5$.

82) Assistent #85553 "85553 - Use the distribut..."

Use the distributive property to multiply.

$$-1(-6m-8)$$

Type your answers without any spaces and in standard form.
Standard Form: $3x-5y+z+5$. Make sure to write $3+-5$ as $3-5$.

83) Assistent #85554 "85554 - Use the distribut..."

Use the distributive property to multiply.

$$-8(-6m-6)$$

Type your answers without any spaces and in standard form.
Standard Form: $3x-5y+z+5$. Make sure to write $3+-5$ as $3-5$.

84) Assistent #85555 "85555 - Use the distribut..."

Use the distributive property to multiply.

$$-8(-8m-2)$$

Type your answers without any spaces and in standard form.
Standard Form: $3x-5y+z+5$. Make sure to write $3+-5$ as $3-5$.

Standard Form: $3x-5y+z+5$. Make sure to write $3+-5$ as $3-5$

86) Assistent #85557 "85557 - Use the distribut..."

Use the distributive property to multiply.
 $-4(-4m-3)$

Type your answers without any spaces and in standard form.
Standard Form: $3x-5y+z+5$. Make sure to write $3+-5$ as $3-5$

87) Assistent #85558 "85558 - Use the distribut..."

Use the distributive property to multiply.
 $-6(-7m-7)$

Type your answers without any spaces and in standard form.
Standard Form: $3x-5y+z+5$. Make sure to write $3+-5$ as $3-5$

88) Assistent #85559 "85559 - Use the distribut..."

Use the distributive property to multiply.
 $-7(-4m-3)$

Type your answers without any spaces and in standard form.
Standard Form: $3x-5y+z+5$. Make sure to write $3+-5$ as $3-5$

89) Assistent #85560 "85560 - Use the distribut..."

Use the distributive property to multiply.
 $-4(-8m-3)$

Type your answers without any spaces and in standard form.
Standard Form: $3x-5y+z+5$. Make sure to write $3+-5$ as $3-5$

90) Assistent #85561 "85561 - Use the distribut..."

Use the distributive property to multiply.
 $-1(-6m-2)$

Type your answers without any spaces and in standard form.
Standard Form: $3x-5y+z+5$. Make sure to write $3+-5$ as $3-5$

91) Assistent #85562 "85562 - Use the distribut..."

Use the distributive property to multiply.

$$-1(-5m-2)$$

Type your answers without any spaces and in standard form.
Standard Form: $3x-5y+z+5$. Make sure to write $3+-5$ as $3-5$

92) Assistent #85563 "85563 - Use the distribut..."

Use the distributive property to multiply.
 $-8(-5m-10)$

Type your answers without any spaces and in standard form.
Standard Form: $3x-5y+z+5$. Make sure to write $3+-5$ as $3-5$

93) Assistent #85564 "85564 - Use the distribut..."

Use the distributive property to multiply.
 $-10(-10m-2)$

Type your answers without any spaces and in standard form.
Standard Form: $3x-5y+z+5$. Make sure to write $3+-5$ as $3-5$

94) Assistent #85565 "85565 - Use the distribut..."

Use the distributive property to multiply.
 $-5(-1m-5)$

Type your answers without any spaces and in standard form.
Standard Form: $3x-5y+z+5$. Make sure to write $3+-5$ as $3-5$

95) Assistent #85566 "85566 - Use the distribut..."

Use the distributive property to multiply.
 $-1(-9m-6)$

Type your answers without any spaces and in standard form.
Standard Form: $3x-5y+z+5$. Make sure to write $3+-5$ as $3-5$

96) Assistent #85567 "85567 - Use the distribut..."

Use the distributive property to multiply.
 $-4(-6m-1)$

Type your answers without any spaces and in standard form.
Standard Form: $3x-5y+z+5$. Make sure to write $3+-5$ as $3-5$

97) Assistent #85568 "85568 - Use the distribut..."

Use the distributive property to multiply.
 $-3(-8m-4)$

Type your answers without any spaces and in standard form.
Standard Form: $3x-5y+z+5$. Make sure to write $3+-5$ as $3-5$

98) Assistent #85569 "85569 - Use the distribut..."

Use the distributive property to multiply.
 $-8(-1m-7)$

Type your answers without any spaces and in standard form.
Standard Form: $3x-5y+z+5$. Make sure to write $3+-5$ as $3-5$

99) Assistent #85570 "85570 - Use the distribut..."

Use the distributive property to multiply.
 $-4(-2m-3)$

Type your answers without any spaces and in standard form.
Standard Form: $3x-5y+z+5$. Make sure to write $3+-5$ as $3-5$

100) Assistent #85571 "85571 - Use the distribut..."

Use the distributive property to multiply.
 $-8(-3m-3)$

Type your answers without any spaces and in standard form.
Standard Form: $3x-5y+z+5$. Make sure to write $3+-5$ as $3-5$

101) Assistent #85572 "85572 - Use the distribut..."

Use the distributive property to multiply.
 $-7(-6m+3)$

Type your answers without any spaces and in standard form.
Standard Form: $3x-2y+z+5$. Make sure to write $3+-5$ as $3-5$

102) Assistent #85573 "85573 - Use the distribut..."

Use the distributive property to multiply.
 $-8(-2m+4)$

Type your answers without any spaces and in standard form.
Standard Form: $3x-2y+z+5$. Make sure to write $3+-5$ as $3-5$

103) Assistent #85574 "85574 - Use the distribut..."

Use the distributive property to multiply.
 $-5(-5m+10)$

Type your answers without any spaces and in standard form.
Standard Form: $3x-2y+z+5$. Make sure to write $3+-5$ as $3-5$

104) Assistentment #85575 "85575 - Use the distribut..."

Use the distributive property to multiply.
 $-4(-4m+8)$

Type your answers without any spaces and in standard form.
Standard Form: $3x-2y+z+5$. Make sure to write $3+-5$ as $3-5$

105) Assistentment #85576 "85576 - Use the distribut..."

Use the distributive property to multiply.
 $-6(-3m+1)$

Type your answers without any spaces and in standard form.
Standard Form: $3x-2y+z+5$. Make sure to write $3+-5$ as $3-5$

106) Assistentment #85577 "85577 - Use the distribut..."

Use the distributive property to multiply.
 $-7(-6m+3)$

Type your answers without any spaces and in standard form.
Standard Form: $3x-2y+z+5$. Make sure to write $3+-5$ as $3-5$

107) Assistentment #85578 "85578 - Use the distribut..."

Use the distributive property to multiply.
 $-3(-1m+1)$

Type your answers without any spaces and in standard form.
Standard Form: $3x-2y+z+5$. Make sure to write $3+-5$ as $3-5$

108) Assistentment #85579 "85579 - Use the distribut..."

Use the distributive property to multiply.
 $-2(-3m+7)$

Type your answers without any spaces and in standard form.
Standard Form: $3x-2y+z+5$. Make sure to write $3+-5$ as $3-5$

109) Assistentment #85580 "85580 - Use the distribut..."

Use the distributive property to multiply.
 $-3(-10m+5)$

Type your answers without any spaces and in standard form.
Standard Form: $3x-2y+z+5$. Make sure to write $3+-5$ as $3-5$

110) Assistent #85581 "85581 - Use the distribut..."

Use the distributive property to multiply.

$$-3(-4m+4)$$

Type your answers without any spaces and in standard form.

Standard Form: $3x-2y+z+5$. Make sure to write $3+-5$ as $3-5$

111) Assistent #85582 "85582 - Use the distribut..."

Use the distributive property to multiply.

$$-9(-5m+5)$$

Type your answers without any spaces and in standard form.

Standard Form: $3x-2y+z+5$. Make sure to write $3+-5$ as $3-5$

112) Assistent #85583 "85583 - Use the distribut..."

Use the distributive property to multiply.

$$-5(-4m+6)$$

Type your answers without any spaces and in standard form.

Standard Form: $3x-2y+z+5$. Make sure to write $3+-5$ as $3-5$

113) Assistent #85584 "85584 - Use the distribut..."

Use the distributive property to multiply.

$$-3(-6m+3)$$

Type your answers without any spaces and in standard form.

Standard Form: $3x-2y+z+5$. Make sure to write $3+-5$ as $3-5$

114) Assistent #85585 "85585 - Use the distribut..."

Use the distributive property to multiply.

$$-5(-1m+10)$$

Type your answers without any spaces and in standard form.

Standard Form: $3x-2y+z+5$. Make sure to write $3+-5$ as $3-5$

115) Assistent #85586 "85586 - Use the distribut..."

Use the distributive property to multiply.

$$-4(-1m+9)$$

Type your answers without any spaces and in standard form.

Standard Form: $3x-2y+z+5$. Make sure to write $3+-5$ as $3-5$

116) Assistent #85587 "85587 - Use the distribut..."

Use the distributive property to multiply.
 $-1(-5m+8)$

Type your answers without any spaces and in standard form.
Standard Form: $3x-2y+z+5$. Make sure to write $3+-5$ as $3-5$

117) Assistent #85588 "85588 - Use the distribut..."

Use the distributive property to multiply.
 $-6(-8m+7)$

Type your answers without any spaces and in standard form.
Standard Form: $3x-2y+z+5$. Make sure to write $3+-5$ as $3-5$

118) Assistent #85589 "85589 - Use the distribut..."

Use the distributive property to multiply.
 $-9(-9m+4)$

Type your answers without any spaces and in standard form.
Standard Form: $3x-2y+z+5$. Make sure to write $3+-5$ as $3-5$

119) Assistent #85590 "85590 - Use the distribut..."

Use the distributive property to multiply.
 $-9(-6m+9)$

Type your answers without any spaces and in standard form.
Standard Form: $3x-2y+z+5$. Make sure to write $3+-5$ as $3-5$

120) Assistent #85591 "85591 - Use the distribut..."

Use the distributive property to multiply.
 $-3(-10m+3)$

Type your answers without any spaces and in standard form.
Standard Form: $3x-2y+z+5$. Make sure to write $3+-5$ as $3-5$

121) Assistent #85592 "85592 - Use the distribut..."

Use the distributive property to multiply.
 $-3(9m+4)$

Type your answers without any spaces and in standard form.
Standard Form: $3x-2y+z+5$. Make sure to write $3+-5$ as $3-5$

122) Assistent #85593 "85593 - Use the distribut..."

Use the distributive property to multiply.

$$-2(6m+9)$$

Type your answers without any spaces and in standard form.
Standard Form: $3x-2y+z+5$. Make sure to write $3+-5$ as $3-5$

123) Assistent #85594 "85594 - Use the distribut..."

Use the distributive property to multiply.
 $-10(2m+10)$

Type your answers without any spaces and in standard form.
Standard Form: $3x-2y+z+5$. Make sure to write $3+-5$ as $3-5$

124) Assistent #85595 "85595 - Use the distribut..."

Use the distributive property to multiply.
 $-5(6m+4)$

Type your answers without any spaces and in standard form.
Standard Form: $3x-2y+z+5$. Make sure to write $3+-5$ as $3-5$

125) Assistent #85596 "85596 - Use the distribut..."

Use the distributive property to multiply.
 $-3(1m+3)$

Type your answers without any spaces and in standard form.
Standard Form: $3x-2y+z+5$. Make sure to write $3+-5$ as $3-5$

126) Assistent #85597 "85597 - Use the distribut..."

Use the distributive property to multiply.
 $-5(3m+5)$

Type your answers without any spaces and in standard form.
Standard Form: $3x-2y+z+5$. Make sure to write $3+-5$ as $3-5$

127) Assistent #85598 "85598 - Use the distribut..."

Use the distributive property to multiply.
 $-4(4m+10)$

Type your answers without any spaces and in standard form.
Standard Form: $3x-2y+z+5$. Make sure to write $3+-5$ as $3-5$

128) Assistent #85599 "85599 - Use the distribut..."

Use the distributive property to multiply.
 $-9(8m+7)$

Type your answers without any spaces and in standard form.
Standard Form: $3x-2y+z+5$. Make sure to write $3+-5$ as $3-5$

129) Assistent #85600 "85600 - Use the distribut..."

Use the distributive property to multiply.
 $-5(2m+10)$

Type your answers without any spaces and in standard form.
Standard Form: $3x-2y+z+5$. Make sure to write $3+-5$ as $3-5$

130) Assistent #85601 "85601 - Use the distribut..."

Use the distributive property to multiply.
 $-8(4m+7)$

Type your answers without any spaces and in standard form.
Standard Form: $3x-2y+z+5$. Make sure to write $3+-5$ as $3-5$

131) Assistent #85602 "85602 - Use the distribut..."

Use the distributive property to multiply.
 $-2(10m+4)$

Type your answers without any spaces and in standard form.
Standard Form: $3x-2y+z+5$. Make sure to write $3+-5$ as $3-5$

132) Assistent #85603 "85603 - Use the distribut..."

Use the distributive property to multiply.
 $-2(8m+3)$

Type your answers without any spaces and in standard form.
Standard Form: $3x-2y+z+5$. Make sure to write $3+-5$ as $3-5$

133) Assistent #85604 "85604 - Use the distribut..."

Use the distributive property to multiply.
 $-1(4m+5)$

Type your answers without any spaces and in standard form.

Standard Form: $3x-2y+z+5$. Make sure to write $3+-5$ as $3-5$

134) Assistent #85605 "85605 - Use the distribut..."

Use the distributive property to multiply.
 $-1(8m+4)$

Type your answers without any spaces and in standard form.
Standard Form: $3x-2y+z+5$. Make sure to write $3+-5$ as $3-5$

135) Assistent #85606 "85606 - Use the distribut..."

Use the distributive property to multiply.
 $-9(5m+6)$

Type your answers without any spaces and in standard form.
Standard Form: $3x-2y+z+5$. Make sure to write $3+-5$ as $3-5$

136) Assistent #85607 "85607 - Use the distribut..."

Use the distributive property to multiply.
 $-8(4m+3)$

Type your answers without any spaces and in standard form.
Standard Form: $3x-2y+z+5$. Make sure to write $3+-5$ as $3-5$

137) Assistent #85608 "85608 - Use the distribut..."

Use the distributive property to multiply.
 $-8(4m+10)$

Type your answers without any spaces and in standard form.
Standard Form: $3x-2y+z+5$. Make sure to write $3+-5$ as $3-5$

138) Assistent #85609 "85609 - Use the distribut..."

Use the distributive property to multiply.
 $-6(7m+10)$

Type your answers without any spaces and in standard form.
Standard Form: $3x-2y+z+5$. Make sure to write $3+-5$ as $3-5$

Use the distributive property to multiply.
 $-8(2m+9)$

Type your answers without any spaces and in standard form.
Standard Form: $3x-2y+z+5$. Make sure to write $3+-5$ as $3-5$

140) Assistent #85611 "85611 - Use the distribut..."

Use the distributive property to multiply.
 $-8(10m+6)$

Type your answers without any spaces and in standard form.
Standard Form: $3x-2y+z+5$. Make sure to write $3+-5$ as $3-5$

141) Assistent #85612 "85612 - Use the distribut..."

Use the distributive property to multiply.
 $-5(10x+7y+4)$

Type your answers without any spaces and in standard form.
Standard Form: $3x-2y+z+5$. Make sure to write $3+-5$ as $3-5$

142) Assistent #85613 "85613 - Use the distribut..."

Use the distributive property to multiply.
 $-2(9x+4y+1)$

Type your answers without any spaces and in standard form.
Standard Form: $3x-2y+z+5$. Make sure to write $3+-5$ as $3-5$

143) Assistent #85614 "85614 - Use the distribut..."

Use the distributive property to multiply.
 $-4(2x+1y+10)$

Type your answers without any spaces and in standard form.
Standard Form: $3x-2y+z+5$. Make sure to write $3+-5$ as $3-5$

144) Assistent #85615 "85615 - Use the distribut..."

Use the distributive property to multiply.
 $-2(9x+2y+2)$

Type your answers without any spaces and in standard form.
Standard Form: $3x-2y+z+5$. Make sure to write $3+-5$ as $3-5$

145) Assistent #85616 "85616 - Use the distribut..."

Use the distributive property to multiply.
 $-4(4x+9y+6)$

Type your answers without any spaces and in standard form.
Standard Form: $3x-2y+z+5$. Make sure to write $3+-5$ as $3-5$

146) Assistent #85617 "85617 - Use the distribut..."

Use the distributive property to multiply.
 $-2(9x+3y+1)$

Type your answers without any spaces and in standard form.
Standard Form: $3x-2y+z+5$. Make sure to write $3+-5$ as $3-5$

147) Assistent #85618 "85618 - Use the distribut..."

Use the distributive property to multiply.
 $-7(3x+1y+7)$

Type your answers without any spaces and in standard form.
Standard Form: $3x-2y+z+5$. Make sure to write $3+-5$ as $3-5$

148) Assistent #85619 "85619 - Use the distribut..."

Use the distributive property to multiply.
 $-2(6x+3y+1)$

Type your answers without any spaces and in standard form.
Standard Form: $3x-2y+z+5$. Make sure to write $3+-5$ as $3-5$

149) Assistent #85620 "85620 - Use the distribut..."

Use the distributive property to multiply.
 $-2(6x+2y+9)$

Type your answers without any spaces and in standard form.
Standard Form: $3x-2y+z+5$. Make sure to write $3+-5$ as $3-5$

150) Assistent #85621 "85621 - Use the distribut..."

Use the distributive property to multiply.
 $-10(8x+6y+3)$

Type your answers without any spaces and in standard form.
Standard Form: $3x-2y+z+5$. Make sure to write $3+-5$ as $3-5$

151) Assistent #85622 "85622 - Use the distribut..."

Use the distributive property to multiply.
 $-1(2x+10y+10)$

Type your answers without any spaces and in standard form.
Standard Form: $3x-2y+z+5$. Make sure to write $3+-5$ as $3-5$

152) Assistent #85623 "85623 - Use the distribut..."

Use the distributive property to multiply.
 $-8(10x+4y+1)$

Type your answers without any spaces and in standard form.
Standard Form: $3x-2y+z+5$. Make sure to write $3+-5$ as $3-5$

153) Assistent #85624 "85624 - Use the distribut..."

Use the distributive property to multiply.
 $-7(2x+1y+8)$

Type your answers without any spaces and in standard form.
Standard Form: $3x-2y+z+5$. Make sure to write $3+-5$ as $3-5$

154) Assistent #85625 "85625 - Use the distribut..."

Use the distributive property to multiply.
 $-2(1x+2y+7)$

Type your answers without any spaces and in standard form.
Standard Form: $3x-2y+z+5$. Make sure to write $3+-5$ as $3-5$

155) Assistent #85626 "85626 - Use the distribut..."

Use the distributive property to multiply.
 $-5(2x+6y+5)$

Type your answers without any spaces and in standard form.
Standard Form: $3x-2y+z+5$. Make sure to write $3+-5$ as $3-5$

156) Assistent #85627 "85627 - Use the distribut..."

Use the distributive property to multiply.
 $-6(10x+4y+6)$

Type your answers without any spaces and in standard form.
Standard Form: $3x-2y+z+5$. Make sure to write $3+-5$ as $3-5$

157) Assistent #85628 "85628 - Use the distribut..."

Use the distributive property to multiply.
 $-10(2x+1y+2)$

Type your answers without any spaces and in standard form.

Standard Form: $3x-2y+z+5$. Make sure to write $3+-5$ as $3-5$

158) Assistentment #85629 "85629 - Use the distribut..."

Use the distributive property to multiply.

$$-1(1x+1y+2)$$

Type your answers without any spaces and in standard form.

Standard Form: $3x-2y+z+5$. Make sure to write $3+-5$ as $3-5$

159) Assistentment #85630 "85630 - Use the distribut..."

Use the distributive property to multiply.

$$-2(1x+1y+10)$$

Type your answers without any spaces and in standard form.

Standard Form: $3x-2y+z+5$. Make sure to write $3+-5$ as $3-5$

160) Assistentment #85631 "85631 - Use the distribut..."

Use the distributive property to multiply.

$$-3(10x+6y+7)$$

Type your answers without any spaces and in standard form.

Standard Form: $3x-2y+z+5$. Make sure to write $3+-5$ as $3-5$

161) Assistentment #85632 "85632 - Use the distribut..."

Use the distributive property to multiply.

$$6(-2x-2y-4)$$

Type your answers without any spaces and in standard form.

Standard Form: $3x-2y+z+5$. Make sure to write $3+-5$ as $3-5$

162) Assistentment #85633 "85633 - Use the distribut..."

Use the distributive property to multiply.

$$7(-8x-7y-10)$$

Type your answers without any spaces and in standard form.

Standard Form: $3x-2y+z+5$. Make sure to write $3+-5$ as $3-5$

163) Assistentment #85634 "85634 - Use the distribut..."

Use the distributive property to multiply.

$$2(-9x-4y-7)$$

Type your answers without any spaces and in standard form.

Standard Form: $3x-2y+z+5$. Make sure to write $3+-5$ as $3-5$

164) Assistent #85635 "85635 - Use the distribut..."

Use the distributive property to multiply.

$$1(-10x-4y-7)$$

Type your answers without any spaces and in standard form.

Standard Form: $3x-2y+z+5$. Make sure to write $3+-5$ as $3-5$

165) Assistent #85636 "85636 - Use the distribut..."

Use the distributive property to multiply.

$$1(-3x-3y-2)$$

Type your answers without any spaces and in standard form.

Standard Form: $3x-2y+z+5$. Make sure to write $3+-5$ as $3-5$

166) Assistent #85637 "85637 - Use the distribut..."

Use the distributive property to multiply.

$$6(-3x-3y-5)$$

Type your answers without any spaces and in standard form.

Standard Form: $3x-2y+z+5$. Make sure to write $3+-5$ as $3-5$

167) Assistent #85638 "85638 - Use the distribut..."

Use the distributive property to multiply.

$$3(-6x-5y-10)$$

Type your answers without any spaces and in standard form.

Standard Form: $3x-2y+z+5$. Make sure to write $3+-5$ as $3-5$

168) Assistent #85639 "85639 - Use the distribut..."

Use the distributive property to multiply.

$$3(-1x-4y-4)$$

Type your answers without any spaces and in standard form.

Standard Form: $3x-2y+z+5$. Make sure to write $3+-5$ as $3-5$

169) Assistent #85640 "85640 - Use the distribut..."

Use the distributive property to multiply.

$$9(-4x-7y-9)$$

Type your answers without any spaces and in standard form.

Standard Form: $3x-2y+z+5$. Make sure to write $3+-5$ as $3-5$

170) Assistent #85641 "85641 - Use the distribut..."

Use the distributive property to multiply.

$$4(-7x-8y-10)$$

Type your answers without any spaces and in standard form.
Standard Form: $3x-2y+z+5$. Make sure to write $3+-5$ as $3-5$

171) Assistent #85642 "85642 - Use the distribut..."

Use the distributive property to multiply.

$$8(-1x-8y-3)$$

Type your answers without any spaces and in standard form.
Standard Form: $3x-2y+z+5$. Make sure to write $3+-5$ as $3-5$

172) Assistent #85643 "85643 - Use the distribut..."

Use the distributive property to multiply.

$$8(-8x-2y-3)$$

Type your answers without any spaces and in standard form.
Standard Form: $3x-2y+z+5$. Make sure to write $3+-5$ as $3-5$

173) Assistent #85644 "85644 - Use the distribut..."

Use the distributive property to multiply.

$$1(-6x-6y-5)$$

Type your answers without any spaces and in standard form.
Standard Form: $3x-2y+z+5$. Make sure to write $3+-5$ as $3-5$

174) Assistent #85645 "85645 - Use the distribut..."

Use the distributive property to multiply.

$$8(-7x-7y-2)$$

Type your answers without any spaces and in standard form.
Standard Form: $3x-2y+z+5$. Make sure to write $3+-5$ as $3-5$

175) Assistent #85646 "85646 - Use the distribut..."

Use the distributive property to multiply.

$$3(-10x-6y-8)$$

Type your answers without any spaces and in standard form.
Standard Form: $3x-2y+z+5$. Make sure to write $3+-5$ as $3-5$

176) Assistent #85647 "85647 - Use the distribut..."

Use the distributive property to multiply.

$$3(-8x-6y-7)$$

Type your answers without any spaces and in standard form.
Standard Form: $3x-2y+z+5$. Make sure to write $3+-5$ as $3-5$

177) Assistent #85648 "85648 - Use the distribut..."

Use the distributive property to multiply.

$$2(-6x-7y-5)$$

Type your answers without any spaces and in standard form.
Standard Form: $3x-2y+z+5$. Make sure to write $3+-5$ as $3-5$

178) Assistent #85649 "85649 - Use the distribut..."

Use the distributive property to multiply.

$$4(-7x-9y-9)$$

Type your answers without any spaces and in standard form.
Standard Form: $3x-2y+z+5$. Make sure to write $3+-5$ as $3-5$

179) Assistent #85650 "85650 - Use the distribut..."

Use the distributive property to multiply.

$$1(-9x-1y-10)$$

Type your answers without any spaces and in standard form.
Standard Form: $3x-2y+z+5$. Make sure to write $3+-5$ as $3-5$

180) Assistent #85651 "85651 - Use the distribut..."

Use the distributive property to multiply.

$$1(-10x-4y-3)$$

Type your answers without any spaces and in standard form.
Standard Form: $3x-2y+z+5$. Make sure to write $3+-5$ as $3-5$

181) Assistent #85652 "85652 - Use the distribut..."

Use the distributive property to multiply.

$$-10(9x-9y+8)$$

Type your answers without any spaces and in standard form.
Standard Form: $3x-2y+z+5$. Make sure to write $3+-5$ as $3-5$

182) Assistent #85653 "85653 - Use the distribut..."

Use the distributive property to multiply.

$$-1(7x-6y+1)$$

Type your answers without any spaces and in standard form.
Standard Form: $3x-2y+z+5$. Make sure to write $3+-5$ as $3-5$

183) Assistent #85654 "85654 - Use the distribut..."

Use the distributive property to multiply.
 $-3(4x-5y+1)$

Type your answers without any spaces and in standard form.
Standard Form: $3x-2y+z+5$. Make sure to write $3+-5$ as $3-5$

184) Assistent #85655 "85655 - Use the distribut..."

Use the distributive property to multiply.
 $-4(10x-5y+6)$

Type your answers without any spaces and in standard form.
Standard Form: $3x-2y+z+5$. Make sure to write $3+-5$ as $3-5$

185) Assistent #85656 "85656 - Use the distribut..."

Use the distributive property to multiply.
 $-1(10x-4y+9)$

Type your answers without any spaces and in standard form.
Standard Form: $3x-2y+z+5$. Make sure to write $3+-5$ as $3-5$

186) Assistent #85657 "85657 - Use the distribut..."

Use the distributive property to multiply.
 $-1(7x-4y+5)$

Type your answers without any spaces and in standard form.
Standard Form: $3x-2y+z+5$. Make sure to write $3+-5$ as $3-5$

187) Assistent #85658 "85658 - Use the distribut..."

Use the distributive property to multiply.
 $-8(2x-8y+3)$

Type your answers without any spaces and in standard form.
Standard Form: $3x-2y+z+5$. Make sure to write $3+-5$ as $3-5$

188) Assistent #85659 "85659 - Use the distribut..."

Use the distributive property to multiply.
 $-6(3x-3y+8)$

Type your answers without any spaces and in standard form.
Standard Form: $3x-2y+z+5$. Make sure to write $3+-5$ as $3-5$

189) Assistentment #85660 "85660 - Use the distribut..."

Use the distributive property to multiply.
 $-10(7x-7y+8)$

Type your answers without any spaces and in standard form.
Standard Form: $3x-2y+z+5$. Make sure to write $3+-5$ as $3-5$

190) Assistentment #85661 "85661 - Use the distribut..."

Use the distributive property to multiply.
 $-10(3x-6y+4)$

Type your answers without any spaces and in standard form.
Standard Form: $3x-2y+z+5$. Make sure to write $3+-5$ as $3-5$

191) Assistentment #85662 "85662 - Use the distribut..."

Use the distributive property to multiply.
 $-9(9x-5y+3)$

Type your answers without any spaces and in standard form.
Standard Form: $3x-2y+z+5$. Make sure to write $3+-5$ as $3-5$

192) Assistentment #85663 "85663 - Use the distribut..."

Use the distributive property to multiply.
 $-3(8x-4y+5)$

Type your answers without any spaces and in standard form.
Standard Form: $3x-2y+z+5$. Make sure to write $3+-5$ as $3-5$

193) Assistentment #85664 "85664 - Use the distribut..."

Use the distributive property to multiply.
 $-6(1x-6y+2)$

Type your answers without any spaces and in standard form.
Standard Form: $3x-2y+z+5$. Make sure to write $3+-5$ as $3-5$

194) Assistentment #85665 "85665 - Use the distribut..."

Use the distributive property to multiply.
 $-3(5x-8y+4)$

Type your answers without any spaces and in standard form.
Standard Form: $3x-2y+z+5$. Make sure to write $3+-5$ as $3-5$

195) Assistent #85666 "85666 - Use the distribut..."

Use the distributive property to multiply.

$$-6(2x-4y+8)$$

Type your answers without any spaces and in standard form.

Standard Form: $3x-2y+z+5$. Make sure to write $3+-5$ as $3-5$

196) Assistent #85667 "85667 - Use the distribut..."

Use the distributive property to multiply.

$$-9(9x-3y+10)$$

Type your answers without any spaces and in standard form.

Standard Form: $3x-2y+z+5$. Make sure to write $3+-5$ as $3-5$

197) Assistent #85668 "85668 - Use the distribut..."

Use the distributive property to multiply.

$$-2(3x-10y+8)$$

Type your answers without any spaces and in standard form.

Standard Form: $3x-2y+z+5$. Make sure to write $3+-5$ as $3-5$

198) Assistent #85669 "85669 - Use the distribut..."

Use the distributive property to multiply.

$$-5(2x-3y+8)$$

Type your answers without any spaces and in standard form.

Standard Form: $3x-2y+z+5$. Make sure to write $3+-5$ as $3-5$

199) Assistent #85670 "85670 - Use the distribut..."

Use the distributive property to multiply.

$$-9(5x-6y+7)$$

Type your answers without any spaces and in standard form.

Standard Form: $3x-2y+z+5$. Make sure to write $3+-5$ as $3-5$

200) Assistent #85671 "85671 - Use the distribut..."

Use the distributive property to multiply.

$$-3(4x-6y+6)$$

Type your answers without any spaces and in standard form.

Standard Form: $3x-2y+z+5$. Make sure to write $3+-5$ as $3-5$

Problem Set % - - "Multiplication and Division Integers - THE SKILL BUILDING SET"

id:[11899]

1) Assistent #99263 "99263 - 27443 - Division-Integers: positive / negative : Easy using table"

What is $25 \div (-5)$?

2) Assistent #99264 "99264 - 27443 - Division-Integers: positive / negative : Easy using table"

What is $24 \div (-8)$?

3) Assistent #99265 "99265 - 27443 - Division-Integers: positive / negative : Easy using table"

What is $10 \div (-1)$?

4) Assistent #99266 "99266 - 27443 - Division-Integers: positive / negative : Easy using table"

What is $21 \div (-7)$?

5) Assistent #99267 "99267 - 27443 - Division-Integers: positive / negative : Easy using table"

What is $5 \div (-5)$?

6) Assistent #99268 "99268 - 27443 - Division-Integers: positive / negative : Easy using table"

What is $15 \div (-3)$?

7) Assistent #99269 "99269 - 27443 - Division-Integers: positive / negative : Easy using table"

What is $49 \div (-7)$?

9) Assistent #99271 "99271 - 27443 - Division-Integers: positive / negative : Easy using table"

What is $10 \div (-1)$?

10) Assistent #99273 "99273 - 27443 - Division-Integers: positive / negative : Easy using table"

What is $32 \div (-8)$?

11) Assistent #99274 "99274 - 27443 - Division-Integers: positive / negative : Easy using table"

What is $21 \div (-7)$?

12) Assistent #99275 "99275 - 27443 - Division-Integers: positive / negative : Easy using table"

What is $100 \div (-10)$?

13) Assistent #99276 "99276 - 27443 - Division-Integers: positive / negative : Easy using table"

What is $70 \div (-7)$?

14) Assistent #99277 "99277 - 27443 - Division-Integers: positive / negative : Easy using table"

What is $42 \div (-7)$?

15) Assistent #99278 "99278 - 27443 - Division-Integers: positive / negative : Easy using table"

What is $24 \div (-6)$?

16) Assistent #99279 "99279 - 27443 - Division-Integers: positive / negative : Easy using table"

What is $40 \div (-5)$?

18) Assistent #99281 "99281 - 27443 - Division-Integers: positive / negative : Easy using table"

What is $63 \div (-7)$?

19) Assistent #99282 "99282 - 27443 - Division-Integers: positive / negative : Easy using table"

What is $4 \div (-2)$?

20) Assistent #99283 "99283 - 27443 - Division-Integers: positive / negative : Easy using table"

What is $27 \div (-9)$?

21) Assistent #99284 "99284 - 27443 - Division-Integers: positive / negative : Easy using table"

What is $36 \div (-4)$?

22) Assistent #99285 "99285 - 27443 - Division-Integers: positive / negative : Easy using table"

What is $20 \div (-5)$?

23) Assistent #99286 "99286 - 27443 - Division-Integers: positive / negative : Easy using table"

What is $18 \div (-9)$?

24) Assistent #99287 "99287 - 27443 - Division-Integers: positive / negative : Easy using table"

What is $4 \div (-2)$?

25) Assistent #99288 "99288 - 27443 - Division-Integers: positive / negative : Easy using table"

What is $18 \div (-9)$?

26) Assisment #99289 "99289 - 27632 - Multiplication-Integers: Positive Times Negative"

What is $5 \cdot (-2)$?

27) Assisment #99290 "99290 - 27632 - Multiplication-Integers: Positive Times Negative"

What is $7 \cdot (-5)$?

28) Assisment #99291 "99291 - 27632 - Multiplication-Integers: Positive Times Negative"

What is $6 \cdot (-2)$?

29) Assisment #99292 "99292 - 27632 - Multiplication-Integers: Positive Times Negative"

What is $3 \cdot (-9)$?

30) Assisment #99293 "99293 - 27632 - Multiplication-Integers: Positive Times Negative"

What is $3 \cdot (-3)$?

31) Assisment #99294 "99294 - 27632 - Multiplication-Integers: Positive Times Negative"

What is $5 \cdot (-9)$?

32) Assisment #99295 "99295 - 27632 - Multiplication-Integers: Positive Times Negative"

What is $1 \cdot (-8)$?

33) Assisment #99296 "99296 - 27632 - Multiplication-Integers: Positive Times Negative"

What is $2 \cdot (-5)$?

34) Assisment #99297 "99297 - 27632 - Multiplication-Integers: Positive Times Negative"

What is $5 \cdot (-5)$?

35) Assisment #99298 "99298 - 27632 - Multiplication-Integers: Positive Times Negative"

What is $4 \cdot (-9)$?

36) Assisment #99299 "99299 - 27632 - Multiplication-Integers: Positive Times Negative"

What is $2 \cdot (-9)$?

37) Assistent #99300 "99300 - 27632 - Multiplication-Integers: Positive Times Negative"

What is $2 \cdot (-8)$?

38) Assistent #99301 "99301 - 27632 - Multiplication-Integers: Positive Times Negative"

What is $5 \cdot (-7)$?

39) Assistent #99302 "99302 - 27632 - Multiplication-Integers: Positive Times Negative"

What is $3 \cdot (-2)$?

40) Assistent #99303 "99303 - 27632 - Multiplication-Integers: Positive Times Negative"

What is $10 \cdot (-9)$?

41) Assistent #99304 "99304 - 27632 - Multiplication-Integers: Positive Times Negative"

What is $3 \cdot (-7)$?

42) Assistent #99305 "99305 - 27632 - Multiplication-Integers: Positive Times Negative"

What is $9 \cdot (-9)$?

43) Assistent #99306 "99306 - 27632 - Multiplication-Integers: Positive Times Negative"

What is $5 \cdot (-10)$?

44) Assistent #99307 "99307 - 27632 - Multiplication-Integers: Positive Times Negative"

What is $9 \cdot (-3)$?

45) Assistent #99308 "99308 - 27632 - Multiplication-Integers: Positive Times Negative"

What is $9 \cdot (-10)$?

46) Assistent #99309 "99309 - 27632 - Multiplication-Integers: Positive Times Negative"

What is $9 \cdot (-6)$?

47) Assistent #99310 "99310 - 27632 - Multiplication-Integers: Positive Times Negative"

What is $1 \cdot (-8)$?

48) Assisment #99311 "99311 - 27632 - Multiplication-Integers: Positive Times Negative"
What is $2 \cdot (-8)$?

49) Assisment #99312 "99312 - 27632 - Multiplication-Integers: Positive Times Negative"
What is $5 \cdot (-1)$?

50) Assisment #99313 "99313 - 27632 - Multiplication-Integers: Positive Times Negative"
What is $3 \cdot (-9)$?

51) Assisment #99314 "99314 - 27632 - Multiplication-Integers: Positive Times Negative"
What is $1 \cdot (-6)$?

52) Assisment #99315 "99315 - 27632 - Multiplication-Integers: Positive Times Negative"
What is $8 \cdot (-2)$?

53) Assisment #99316 "99316 - 27632 - Multiplication-Integers: Positive Times Negative"
What is $1 \cdot (-3)$?

54) Assisment #99317 "99317 - 27632 - Multiplication-Integers: Positive Times Negative"
What is $1 \cdot (-2)$?

55) Assisment #99318 "99318 - 27632 - Multiplication-Integers: Positive Times Negative"
What is $4 \cdot (-8)$?

56) Assisment #99319 "99319 - Multiplication - Integers: Negative times Negative"
What is $(-6) \cdot (-3)$?

57) Assisment #99320 "99320 - Multiplication - Integers: Negative times Negative"
What is $(-2) \cdot (-9)$?

58) Assistent #99321 "99321 - Multiplication - Integers: Negative times Negative"

What is $(-7) \cdot (-9)$?

59) Assistent #99322 "99322 - Multiplication - Integers: Negative times Negative"

What is $(-6) \cdot (-5)$?

60) Assistent #99323 "99323 - Multiplication - Integers: Negative times Negative"

What is $(-4) \cdot (-2)$?

61) Assistent #99324 "99324 - Multiplication - Integers: Negative times Negative"

What is $(-8) \cdot (-7)$?

62) Assistent #99325 "99325 - Multiplication - Integers: Negative times Negative"

What is $(-9) \cdot (-10)$?

63) Assistent #99326 "99326 - Multiplication - Integers: Negative times Negative"

What is $(-8) \cdot (-3)$?

64) Assistent #99327 "99327 - Multiplication - Integers: Negative times Negative"

What is $(-9) \cdot (-8)$?

65) Assistent #99328 "99328 - Multiplication - Integers: Negative times Negative"

What is $(-5) \cdot (-2)$?

66) Assistent #99329 "99329 - Multiplication - Integers: Negative times Negative"

What is $(-5) \cdot (-4)$?

67) Assistent #99330 "99330 - Multiplication - Integers: Negative times Negative"

What is $(-2) \cdot (-4)$?

68) Assistent #99331 "99331 - Multiplication - Integers: Negative times Negative"

What is $(-6) \cdot (-8)$?

69) Assistent #99332 "99332 - Multiplication - Integers: Negative times Negative"

What is $(-6) \cdot (-5)$?

70) Assistent #99333 "99333 - Multiplication - Integers: Negative times Negative"

What is $(-6) \cdot (-4)$?

71) Assistent #99334 "99334 - Multiplication - Integers: Negative times Negative"

What is $(-1) \cdot (-7)$?

72) Assistent #99335 "99335 - Multiplication - Integers: Negative times Negative"

What is $(-5) \cdot (-1)$?

73) Assistent #99336 "99336 - Multiplication - Integers: Negative times Negative"

What is $(-6) \cdot (-6)$?

74) Assistent #99337 "99337 - Multiplication - Integers: Negative times Negative"

What is $(-8) \cdot (-10)$?

75) Assistent #99338 "99338 - Multiplication - Integers: Negative times Negative"

What is $(-1) \cdot (-3)$?

76) Assistent #99339 "99339 - Multiplication - Integers: Negative times Negative"

What is $(-5) \cdot (-7)$?

77) Assistent #99340 "99340 - Multiplication - Integers: Negative times Negative"

What is $(-9) \cdot (-10)$?

78) Assistent #99341 "99341 - Multiplication - Integers: Negative times Negative"

What is $(-8) \cdot (-4)$?

79) Assistent #99342 "99342 - Multiplication - Integers: Negative times Negative"

What is $(-5) \cdot (-10)$?

80) Assistent #99343 "99343 - Multiplication - Integers: Negative times Negative"

What is $(-2) \cdot (-10)$?

81) Assistent #99344 "99344 - Multiplication - Integers: Negative times Negative"

What is $(-7) \cdot (-5)$?

82) Assistent #99345 "99345 - Multiplication - Integers: Negative times Negative"

What is $(-5) \cdot (-6)$?

83) Assistent #99346 "99346 - Multiplication - Integers: Negative times Negative"

What is $(-10) \cdot (-7)$?

84) Assistent #99347 "99347 - Multiplication - Integers: Negative times Negative"

What is $(-1) \cdot (-2)$?

85) Assistent #99348 "99348 - Multiplication - Integers: Negative times Negative"

What is $(-10) \cdot (-4)$?

86) Assistent #99349 "99349 - Division-Integers: negative / positive : Easy using table"

What is $(-12) \div 2$?

87) Assistent #99350 "99350 - Division-Integers: negative / positive : Easy using table"

What is $(-35) \div 7$?

88) Assistent #99351 "99351 - Division-Integers: negative / positive : Easy using table"

What is $(-3) \div 1$?

89) Assistent #99352 "99352 - Division-Integers: negative / positive : Easy using table"

What is $(-50) \div 10$?

90) Assisment #99353 "99353 - Division-Integers: negative / positive : Easy using table"

What is $(-32) \div 8$?

91) Assisment #99354 "99354 - Division-Integers: negative / positive : Easy using table"

What is $(-16) \div 4$?

92) Assisment #99355 "99355 - Division-Integers: negative / positive : Easy using table"

What is $(-54) \div 6$?

93) Assisment #99356 "99356 - Division-Integers: negative / positive : Easy using table"

What is $(-18) \div 3$?

94) Assisment #99357 "99357 - Division-Integers: negative / positive : Easy using table"

What is $(-20) \div 4$?

95) Assisment #99358 "99358 - Division-Integers: negative / positive : Easy using table"

What is $(-45) \div 9$?

96) Assisment #99359 "99359 - Division-Integers: negative / positive : Easy using table"

What is $(-10) \div 5$?

97) Assisment #99360 "99360 - Division-Integers: negative / positive : Easy using table"

What is $(-10) \div 5$?

98) Assisment #99361 "99361 - Division-Integers: negative / positive : Easy using table"

What is $(-16) \div 2$?

99) Assisment #99362 "99362 - Division-Integers: negative / positive : Easy using table"

What is $(-72) \div 8$?

100) Assisment #99363 "99363 - Division-Integers: negative / positive : Easy using table"

What is $(-15) \div 5$?

101) Assistent #99364 "99364 - Division-Integers: negative / positive : Easy using table"
What is $(-80) \div 8$?

102) Assistent #99365 "99365 - Division-Integers: negative / positive : Easy using table"
What is $(-27) \div 9$?

103) Assistent #99366 "99366 - Division-Integers: negative / positive : Easy using table"
What is $(-10) \div 2$?

104) Assistent #99367 "99367 - Division-Integers: negative / positive : Easy using table"
What is $(-54) \div 9$?

105) Assistent #99368 "99368 - Division-Integers: negative / positive : Easy using table"
What is $(-18) \div 2$?

106) Assistent #99369 "99369 - Division-Integers: negative / positive : Easy using table"
What is $(-20) \div 2$?

107) Assistent #99370 "99370 - Division-Integers: negative / positive : Easy using table"
What is $(-24) \div 3$?

108) Assistent #99371 "99371 - Division-Integers: negative / positive : Easy using table"
What is $(-16) \div 8$?

109) Assistent #99372 "99372 - Division-Integers: negative / positive : Easy using table"
What is $(-64) \div 8$?

110) Assistent #99373 "99373 - Division-Integers: negative / positive : Easy using table"
What is $(-8) \div 2$?

111) Assistent #99374 "99374 - Division-Integers: negative / positive : Easy using table"

What is $(-63) \div 9$?

112) Assistent #99375 "99375 - Division-Integers: negative / positive : Easy using table"

What is $(-5) \div 5$?

113) Assistent #99376 "99376 - Division-Integers: negative / positive : Easy using table"

What is $(-32) \div 4$?

114) Assistent #99377 "99377 - Division-Integers: negative / positive : Easy using table"

What is $(-7) \div 7$?

115) Assistent #99378 "99378 - Division-Integers: negative / positive : Easy using table"

What is $(-15) \div 3$?

1) Assistent #92211 "92211 - 75988 - 75987 - Perimeter - trapzoid"

What is the perimeter of the trapzoid with the given information?

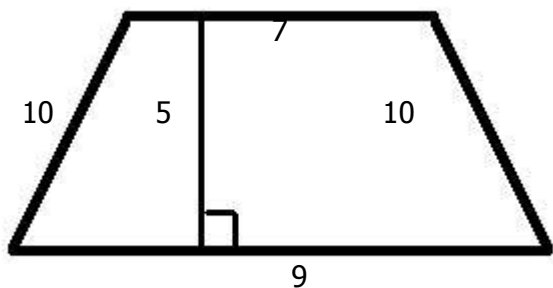

image not to scale

2) Assistent #92212 "92212 - 75988 - 75987 - Perimeter - trapzoid"

What is the perimeter of the trapzoid with the given information?

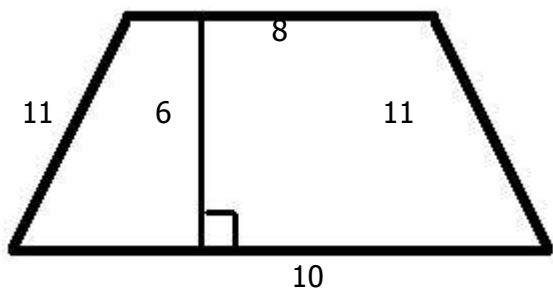

image not to scale

3) Assistent #92213 "92213 - 75988 - 75987 - Perimeter - trapzoid"

What is the perimeter of the trapzoid with the given information?



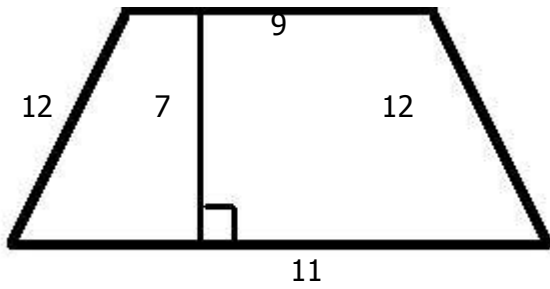

image not to scale

4) Assistent #92214 "92214 - 75988 - 75987 - Perimeter - trapezoid"

What is the perimeter of the trapezoid with the given information?

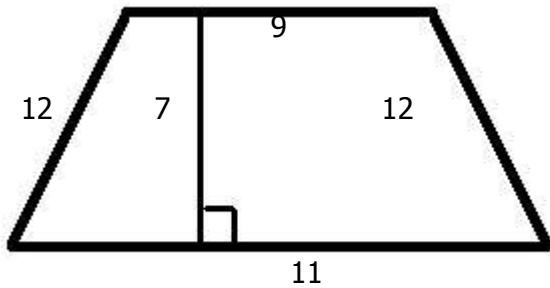

image not to scale

5) Assistent #92215 "92215 - 75988 - 75987 - Perimeter - trapezoid"

What is the perimeter of the trapezoid with the given information?

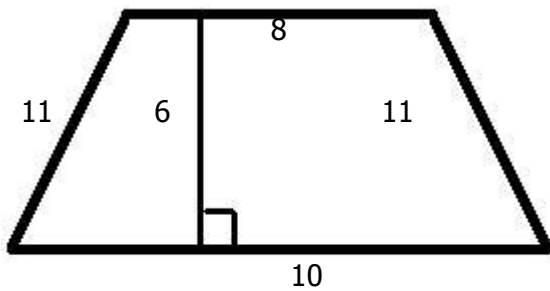

image not to scale

6) Assistent #92216 "92216 - 75988 - 75987 - Perimeter - trapezoid"

What is the perimeter of the trapezoid with the given information?

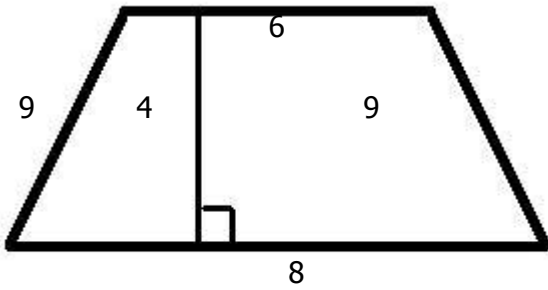

image not to scale

7) Assisment #92217 "92217 - 75988 - 75987 - Perimeter - trapezoid"

What is the perimeter of the trapezoid with the given information?

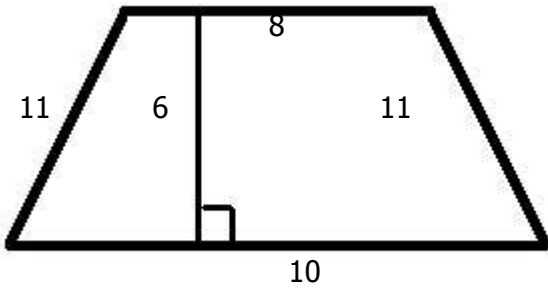

image not to scale

8) Assisment #92218 "92218 - 75988 - 75987 - Perimeter - trapezoid"

What is the perimeter of the rectangle with base of 14 and height of 10?

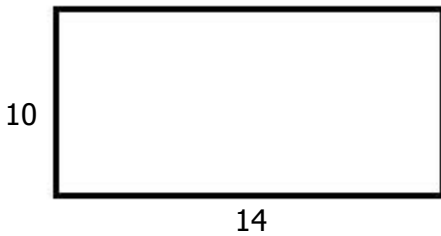

image not to scale

9) Assistent #92219 "92219 - 75988 - 75987 - Perimeter - trapzoid"

What is the perimeter of the rectangle with base of 7 and height of 3?



image not to scale

10) Assistent #92220 "92220 - 75988 - 75987 - Perimeter - trapzoid"

What is the perimeter of the rectangle with base of 14 and height of 10?



image not to scale

11) Assistent #92221 "92221 - 75988 - 75987 - Perimeter - trapzoid"

What is the perimeter of the rectangle with base of 8 and height of 4?



image not to scale

12) Assistent #92222 "92222 - 75988 - 75987 - Perimeter - trapezoid"

What is the perimeter of the rectangle with base of 7 and height of 3?



image not to scale

13) Assistent #92223 "92223 - 75988 - 75987 - Perimeter - trapezoid"

What is the perimeter of the rectangle with base of 10 and height of 6?



image not to scale

14) Assistent #92224 "92224 - 75988 - 75987 - Perimeter - trapezoid"

What is the perimeter of the rectangle with base of 11 and height of 7?

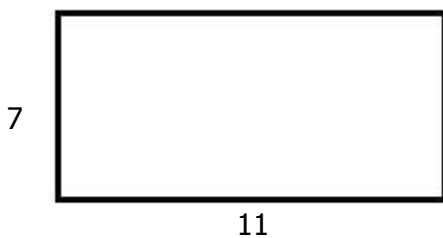

image not to scale

15) Assistent #92225 "92225 - 75681 - 75679 - 75489 - 58264 - perimeter of the rectangle"

What is the perimeter of the rectangle with base of 13 and height of 9?

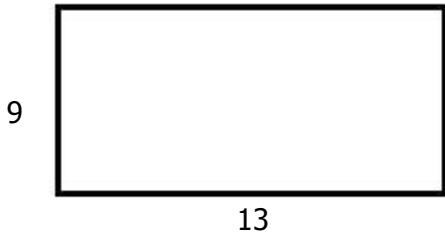

image not to scale

16) Assistent #92226 "92226 - 75681 - 75679 - 75489 - 58264 - perimeter of the rectangle"

What is the perimeter of the rectangle with base of 11 and height of 7?

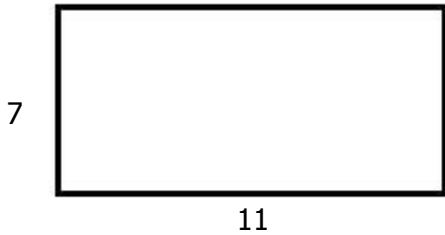

image not to scale

17) Assistent #92227 "92227 - 75681 - 75679 - 75489 - 58264 - perimeter of the rectangle"

What is the perimeter of the rectangle with base of 11 and height of 7?

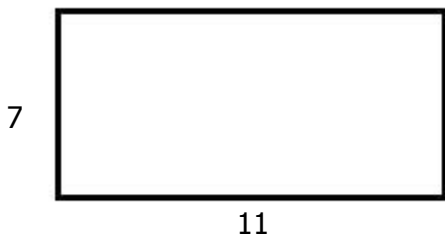

image not to scale

18) Assistent #92228 "92228 - 75681 - 75679 - 75489 - 58264 - perimeter of the rectangle"

What is the perimeter of the rectangle with base of 9 and height of 5?



image not to scale

19) Assistent #92229 "92229 - 75681 - 75679 - 75489 - 58264 - perimeter of the rectangle"

What is the perimeter of the rectangle with base of 15 and height of 11?



image not to scale

20) Assistent #92230 "92230 - 75681 - 75679 - 75489 - 58264 - perimeter of the rectangle"

What is the perimeter of the rectangle with base of 8 and height of 4?



image not to scale

-
- 21) Assistent #92231 "92231 - 75681 - 75679 - 75489 - 58264 - perimeter of the rectangle"**
What is the perimeter of the rectangle with base of 9 and height of 5?



image not to scale

-
- 22) Assistent #92232 "92232 - 76088 - 75988 - 75987 - Perimeter - irregular"**
What is the perimeter of the follwing object with the given information?

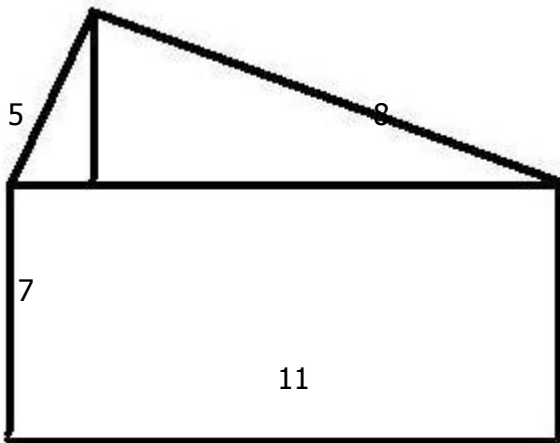

image not to scale

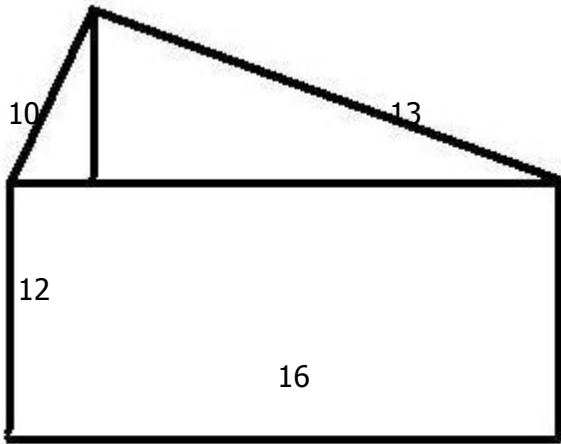

image not to scale

24) Assistent #92234 "92234 - 76088 - 75988 - 75987 - Perimeter - irregular"
What is the perimeter of the follwing object with the given information?

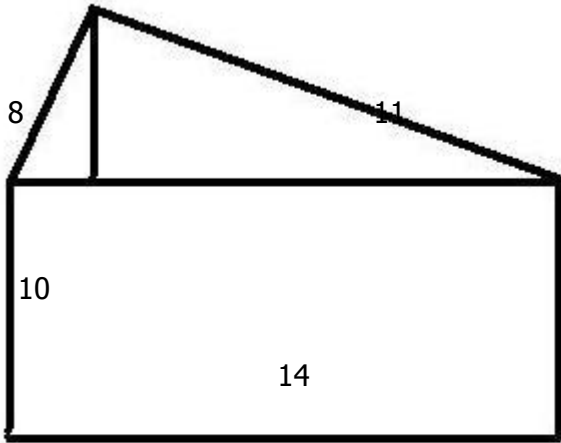

image not to scale

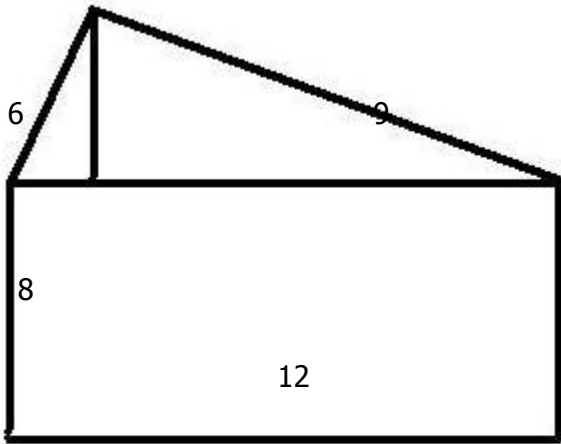

image not to scale

26) Assistent #92236 "92236 - 76088 - 75988 - 75987 - Perimeter - irregular"
What is the perimeter of the follwing object with the given information?

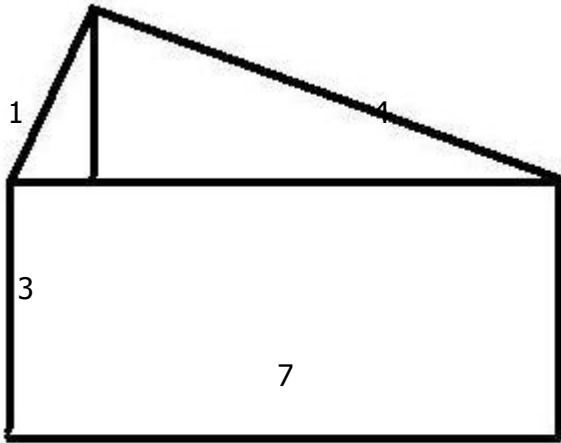

image not to scale

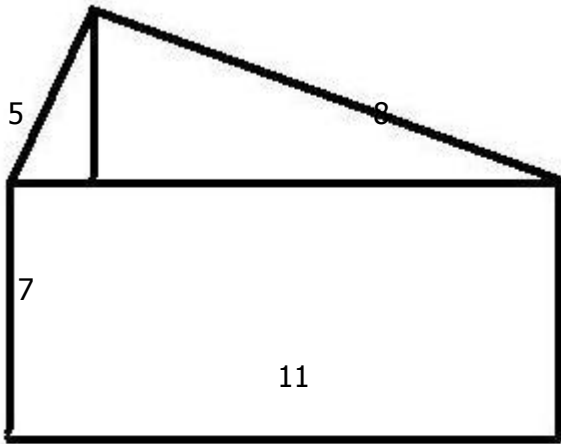

image not to scale

28) Assistent #92238 "92238 - 76088 - 75988 - 75987 - Perimeter - irregular"
What is the perimeter of the follwing object with the given information?

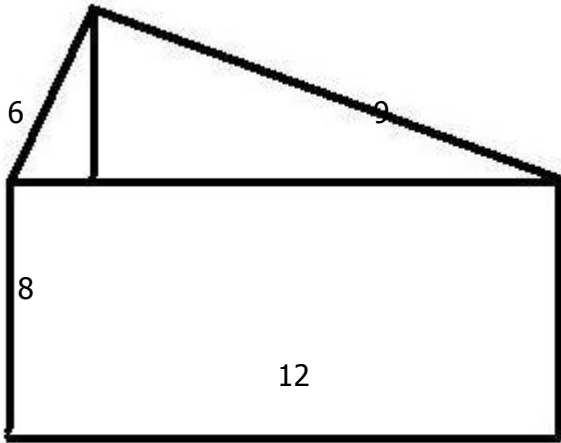

image not to scale

trapezoid"

What is the perimeter of the trapezoid with the given information?

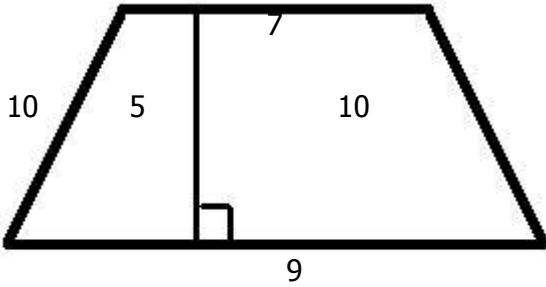

image not to scale

30) Assistent #92240 "92240 - 75742 - 75681 - 75679 - 75489 - 58264 - perimeter of the trapezoid"

What is the perimeter of the trapezoid with the given information?

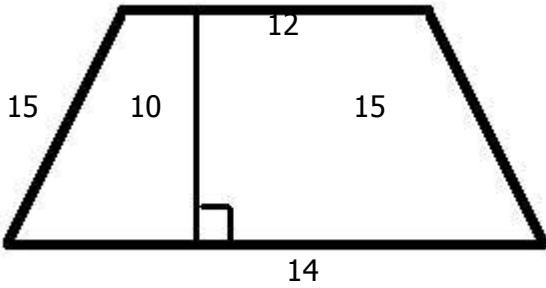

image not to scale

31) Assistent #92241 "92241 - 75742 - 75681 - 75679 - 75489 - 58264 - perimeter of the trapezoid"

What is the perimeter of the trapezoid with the given information?

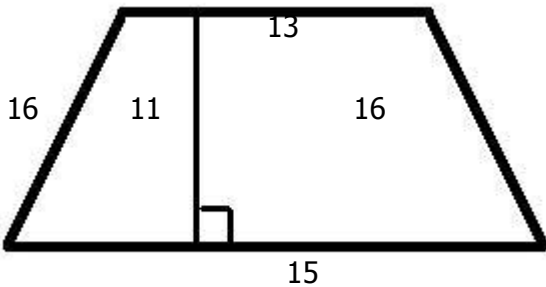

image not to scale

32) Assistent #92242 "92242 - 75742 - 75681 - 75679 - 75489 - 58264 - perimeter of the trapezoid"

What is the perimeter of the trapezoid with the given information?

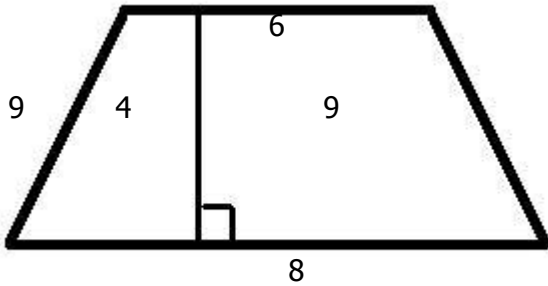

image not to scale

33) Assistent #92243 "92243 - 75742 - 75681 - 75679 - 75489 - 58264 - perimeter of the trapezoid"

What is the perimeter of the trapezoid with the given information?

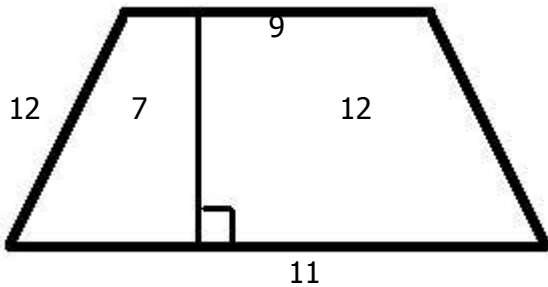

image not to scale

34) Assistent #92244 "92244 - 75742 - 75681 - 75679 - 75489 - 58264 - perimeter of the trapezoid"

What is the perimeter of the trapezoid with the given information?

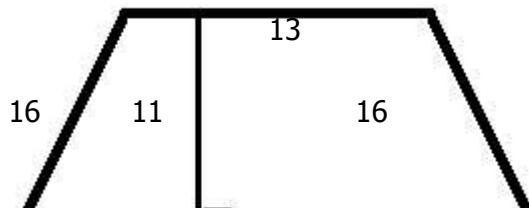



image not to scale

35) Assistent #92245 "92245 - 75742 - 75681 - 75679 - 75489 - 58264 - perimeter of the trapzoid"

What is the perimeter of the trapzoid with the given information?

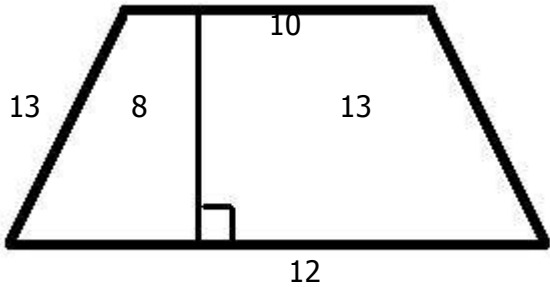

image not to scale

36) Assistent #92246 "92246 - 75489 - 58264 - perimeter of the triangle with base and height"

What is the perimeter of the triangle with the following information?

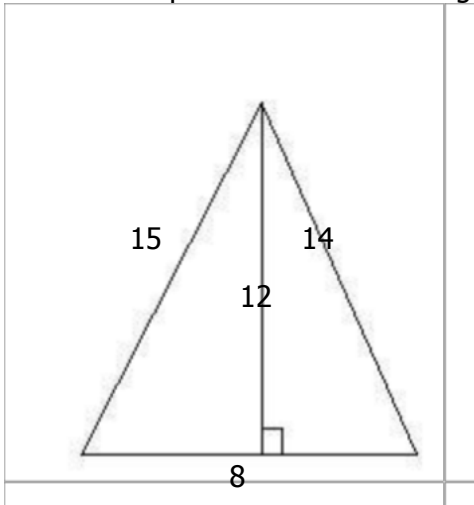

image not to scale

37) Assistent #92247 "92247 - 75489 - 58264 - perimeter of the triangle with base and height"

What is the perimeter of the triangle with the following information?

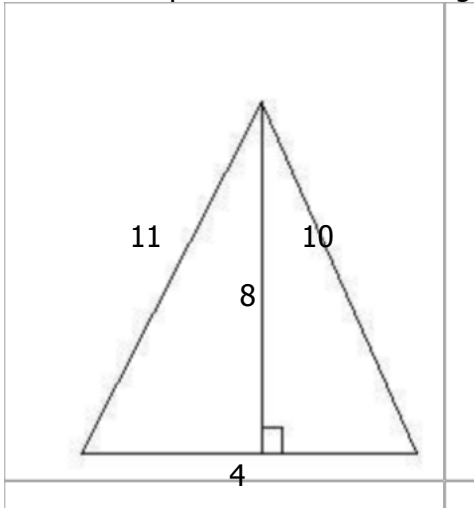

image not to scale

38) Assistent #92248 "92248 - 75489 - 58264 - perimeter of the triangle with base and height"

What is the perimeter of the triangle with the following information?

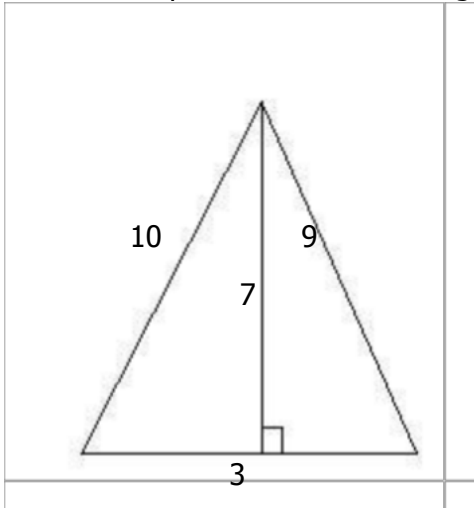
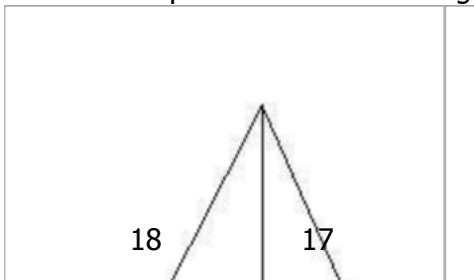

image not to scale

39) Assistent #92249 "92249 - 75489 - 58264 - perimeter of the triangle with base and height"

What is the perimeter of the triangle with the following information?



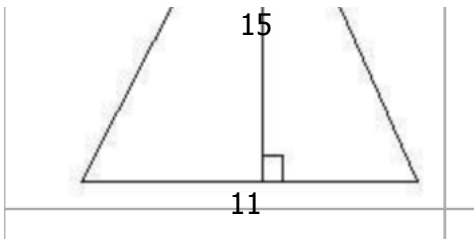

image not to scale

40) Assistent #92250 "92250 - 75489 - 58264 - perimeter of the triangle with base and height"

What is the perimeter of the triangle with the following information?

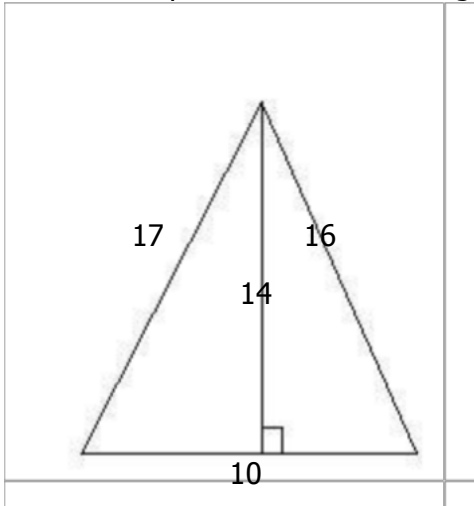

image not to scale

41) Assistent #92251 "92251 - 75489 - 58264 - perimeter of the triangle with base and height"

What is the perimeter of the triangle with the following information?

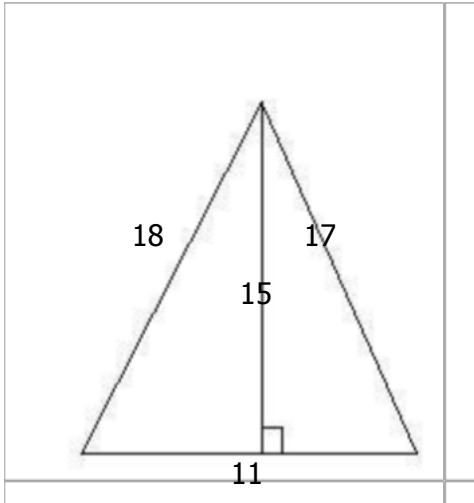

image not to scale

42) Assistent #92252 "92252 - 75489 - 58264 - perimeter of the triangle with base and height"

What is the perimeter of the triangle with the following information?

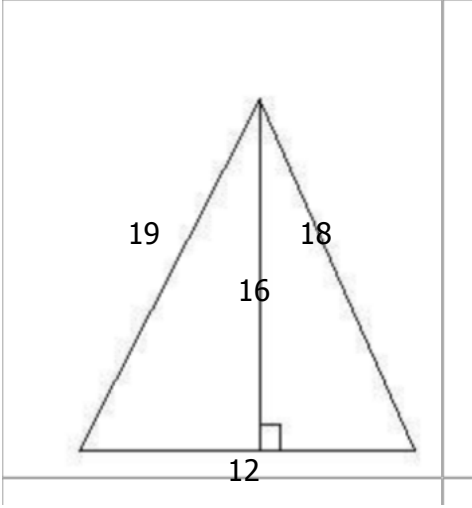

image not to scale

43) Assistent #92253 "92253 - 75986 - 75681 - 75679 - 75489 - 58264 - perimeter of the square"

What is the perimeter of the follwing object with the given information?

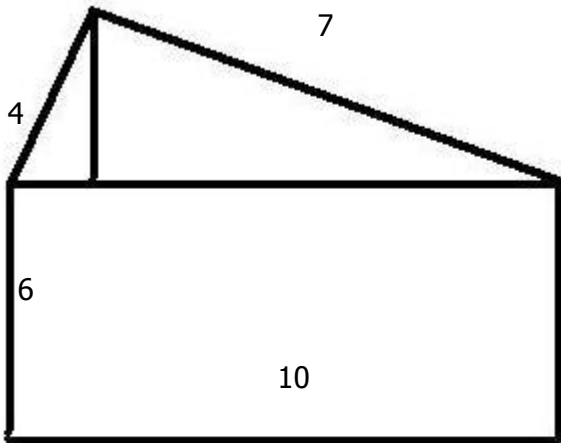

image not to scale

44) Assistent #92254 "92254 - 75986 - 75681 - 75679 - 75489 - 58264 - perimeter of the square"

What is the perimeter of the follwing object with the given information?

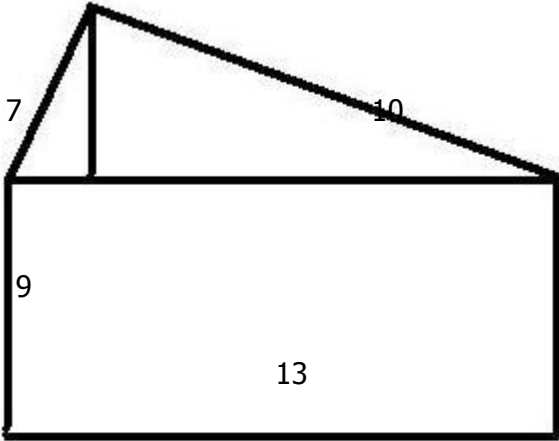

image not to scale

45) Assistent #92255 "92255 - 75986 - 75681 - 75679 - 75489 - 58264 - perimeter of the square"

What is the perimeter of the follwing object with the given information?

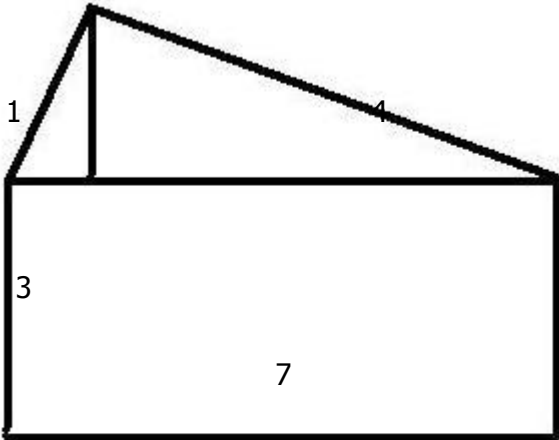

image not to scale

46) Assistent #92256 "92256 - 75986 - 75681 - 75679 - 75489 - 58264 - perimeter of the square"

What is the perimeter of the follwing object with the given information?

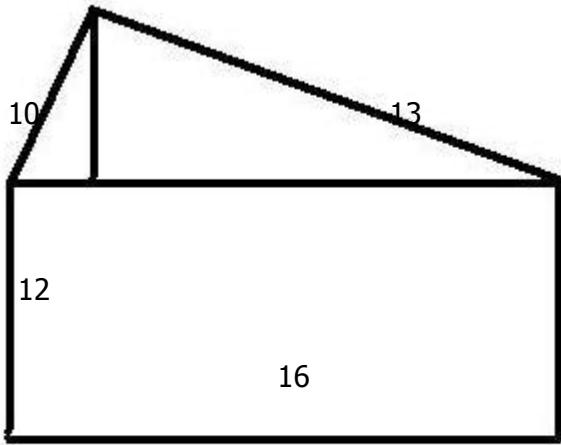

image not to scale

47) Assistent #92257 "92257 - 75986 - 75681 - 75679 - 75489 - 58264 - perimeter of the square"

What is the perimeter of the follwing object with the given information?

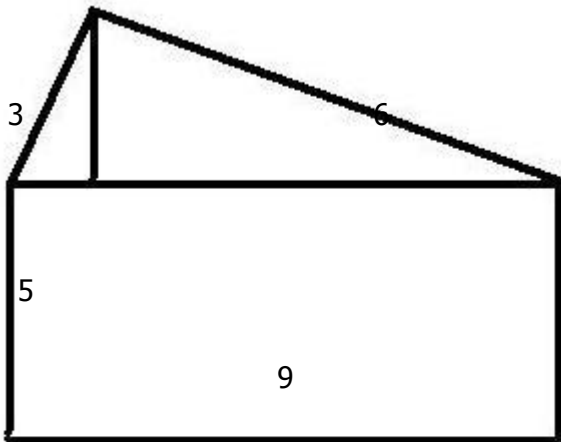

image not to scale

48) Assistent #92258 "92258 - 75986 - 75681 - 75679 - 75489 - 58264 - perimeter of the square"

What is the perimeter of the follwing object with the given information?

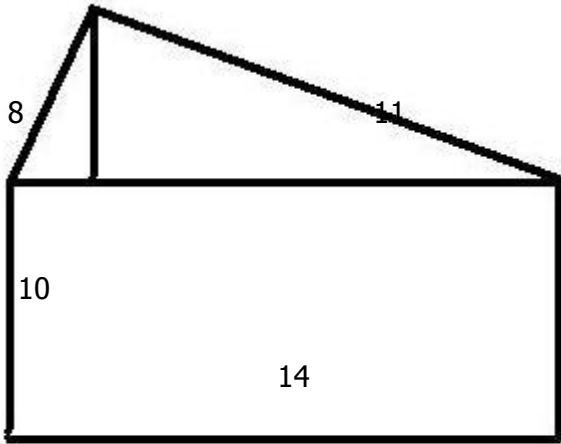

image not to scale

49) Assistent #92259 "92259 - 75986 - 75681 - 75679 - 75489 - 58264 - perimeter of the square"

What is the perimeter of the follwing object with the given information?

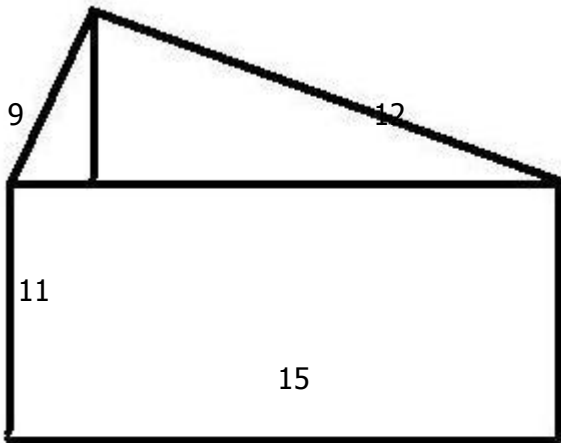

image not to scale

50) Assistent #92260 "92260 - 75988 - 75987 - Perimeter - trapezoid"

What is the perimeter of the parallelogram the given information?

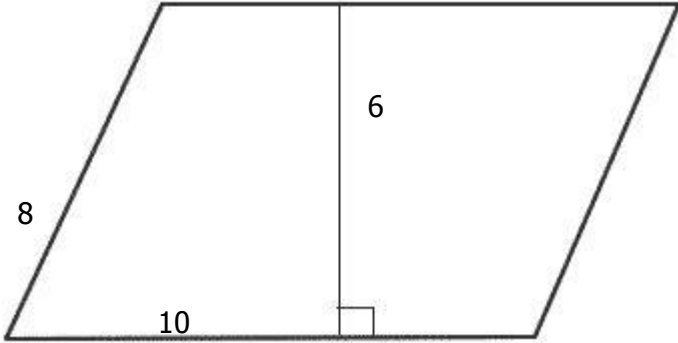

image not to scale

51) Assistent #92261 "92261 - 75988 - 75987 - Perimeter - trapezoid"

What is the perimeter of the parallelogram the given information?

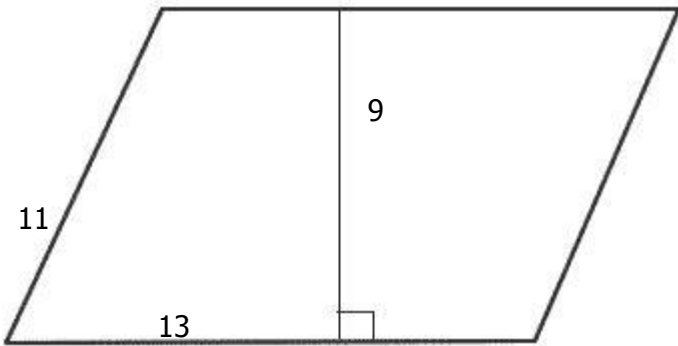
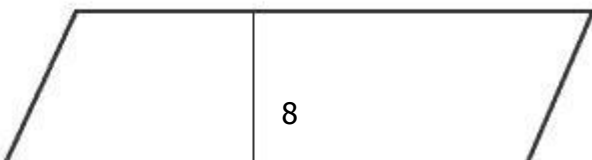

image not to scale

52) Assistent #92262 "92262 - 75988 - 75987 - Perimeter - trapezoid"

What is the perimeter of the parallelogram the given information?



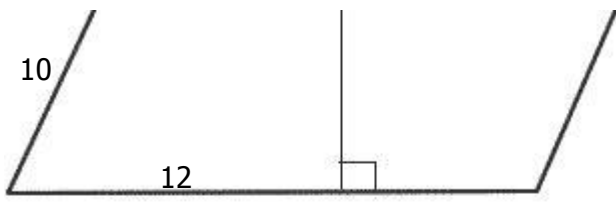

image not to scale

53) Assistent #92263 "92263 - 75988 - 75987 - Perimeter - trapezoid"

What is the perimeter of the parallelogram the given information?

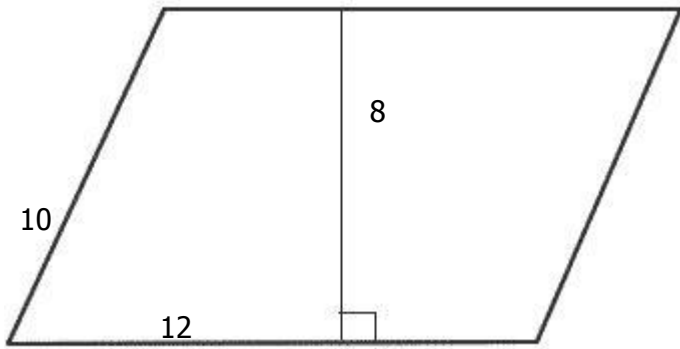

image not to scale

54) Assistent #92264 "92264 - 75988 - 75987 - Perimeter - trapezoid"

What is the perimeter of the parallelogram the given information?

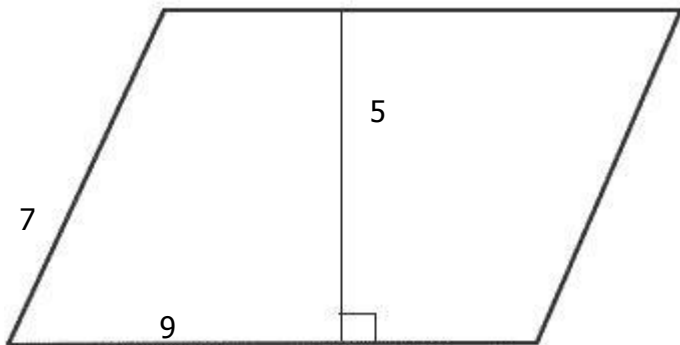

image not to scale

55) Assistent #92265 "92265 - 75988 - 75987 - Perimeter - trapezoid"

What is the perimeter of the parallelogram the given information?

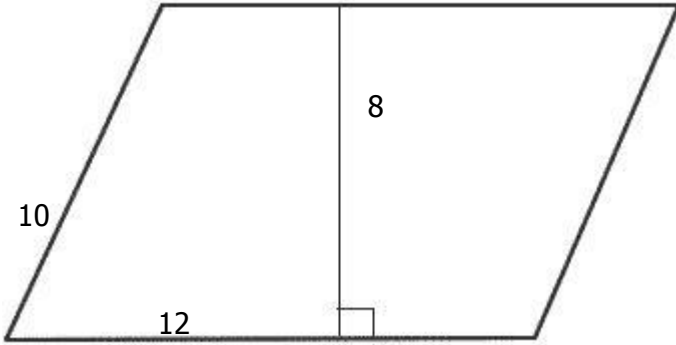

image not to scale

56) Assistent #92266 "92266 - 75988 - 75987 - Perimeter - trapezoid"

What is the perimeter of the parallelogram the given information?

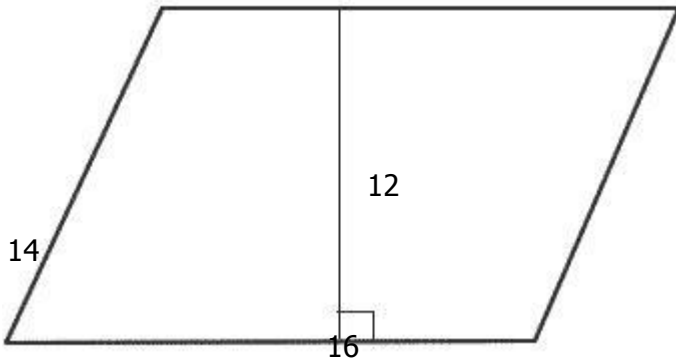
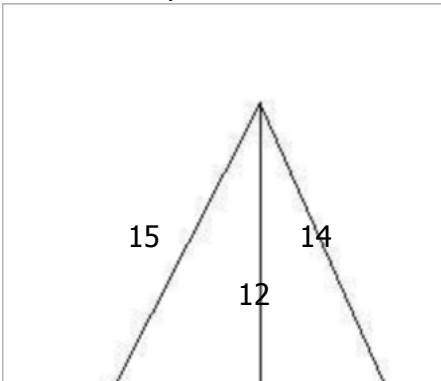

image not to scale

57) Assistent #92267 "92267 - 75991 - 75988 - 75987 - Perimeter - triangle"

What is the perimeter of the triangle with the following information?



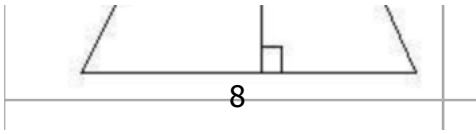

image not to scale

58) Assistent #92268 "92268 - 75991 - 75988 - 75987 - Perimeter - triangle"

What is the perimeter of the triangle with the following information?

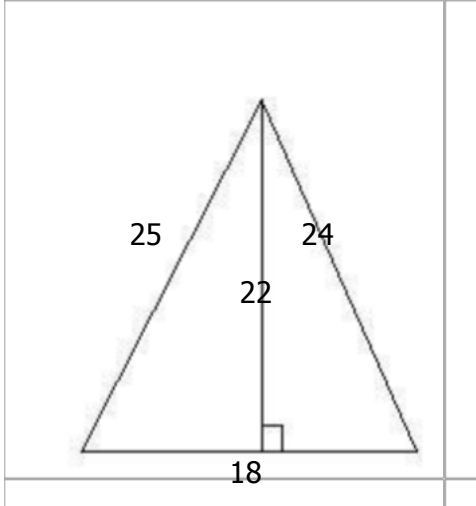

image not to scale

59) Assistent #92269 "92269 - 75991 - 75988 - 75987 - Perimeter - triangle"

What is the perimeter of the triangle with the following information?

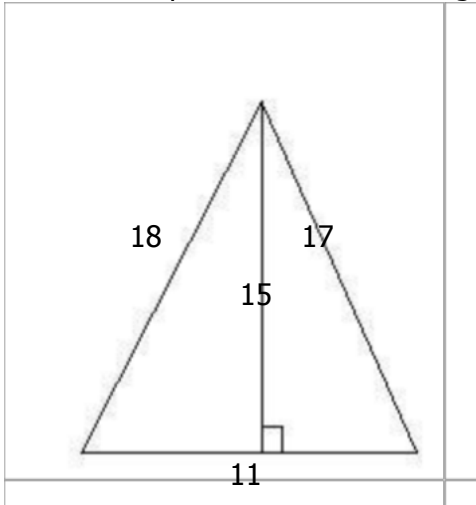

image not to scale

60) Assistent #92270 "92270 - 75991 - 75988 - 75987 - Perimeter - triangle"

What is the perimeter of the triangle with the following information?

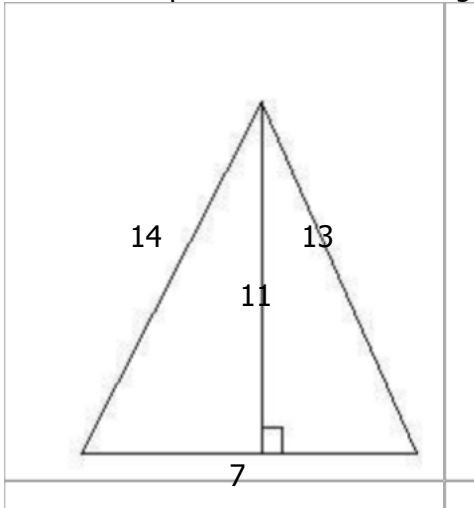

image not to scale

61) Assistent #92271 "92271 - 75991 - 75988 - 75987 - Perimeter - triangle"

What is the perimeter of the triangle with the following information?

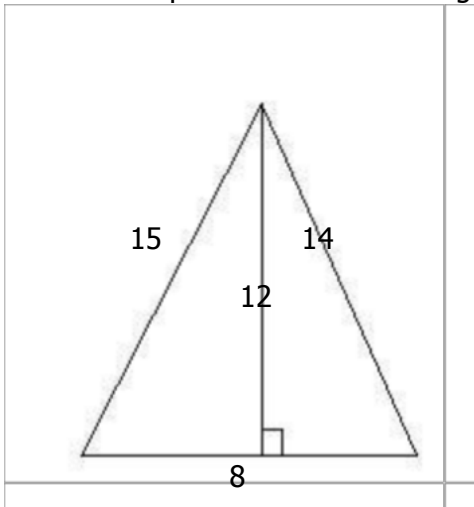
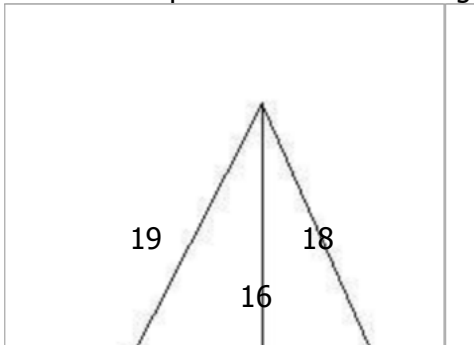

image not to scale

62) Assistent #92272 "92272 - 75991 - 75988 - 75987 - Perimeter - triangle"

What is the perimeter of the triangle with the following information?



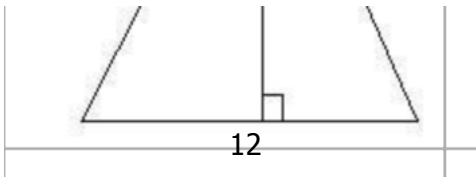

image not to scale

63) Assistent #92273 "92273 - 75991 - 75988 - 75987 - Perimeter - triangle"

What is the perimeter of the triangle with the following information?

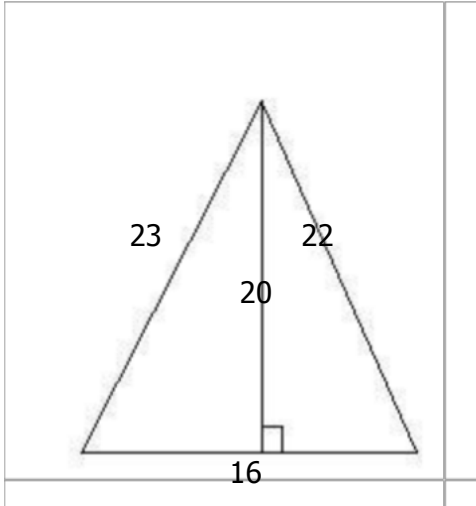

image not to scale

64) Assistent #92274 "92274 - 76090 - 75986 - 75681 - 75679 - 75489 - 58264 - perimeter of the polygon"

What is the perimeter of the follwing regular polygon with 5 sides?

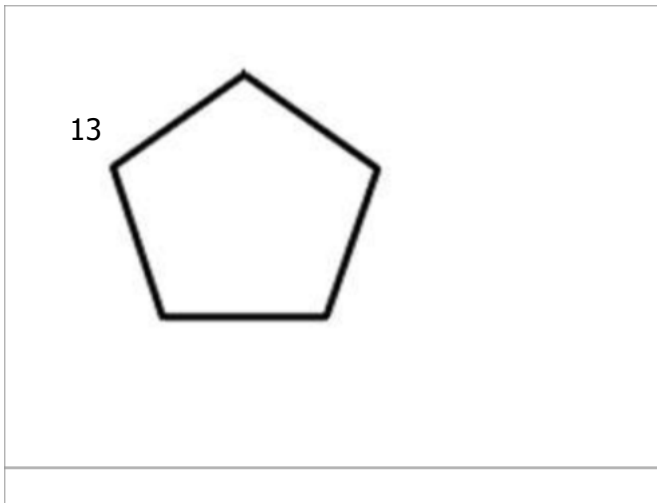

image not to scale

65) Assistent #92275 "92275 - 76090 - 75986 - 75681 - 75679 - 75489 - 58264 - perimeter of the polygon"

What is the perimeter of the follwing regular polygon with 5 sides?

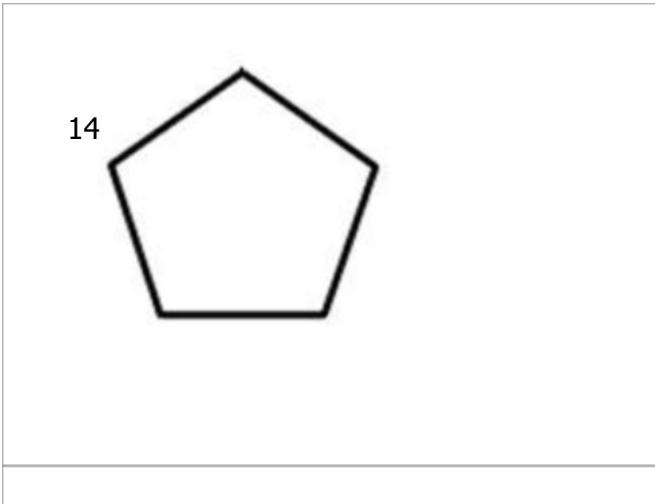

image not to scale

66) Assistent #92276 "92276 - 76090 - 75986 - 75681 - 75679 - 75489 - 58264 - perimeter of the polygon"

What is the perimeter of the follwing regular polygon with 5 sides?

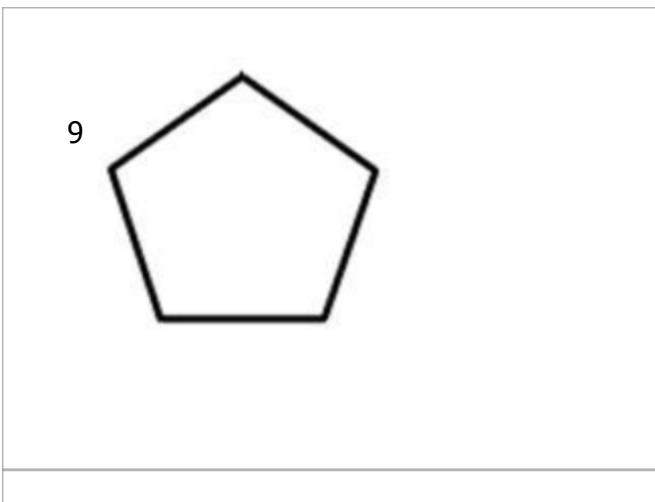

image not to scale

67) Assistent #92277 "92277 - 76090 - 75986 - 75681 - 75679 - 75489 - 58264 - perimeter of the polygon"

What is the perimeter of the following regular polygon with 5 sides?

11

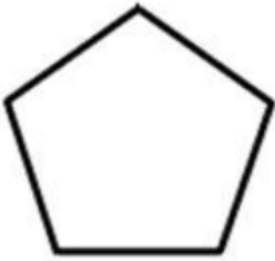

image not to scale

68) Assistent #92278 "92278 - 76090 - 75986 - 75681 - 75679 - 75489 - 58264 - perimeter of the polygon"

What is the perimeter of the following regular polygon with 5 sides?

11

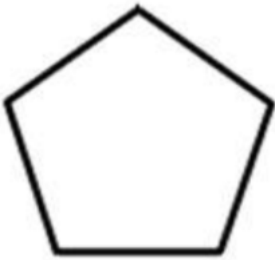

image not to scale

69) Assistent #92279 "92279 - 76090 - 75986 - 75681 - 75679 - 75489 - 58264 - perimeter of the polygon"

What is the perimeter of the following regular polygon with 5 sides?



8

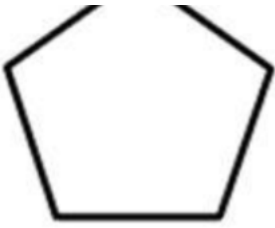

image not to scale

70) Assistent #92280 "92280 - 76090 - 75986 - 75681 - 75679 - 75489 - 58264 - perimeter of the polygon"

What is the perimeter of the follwing regular polygon with 5 sides?

10

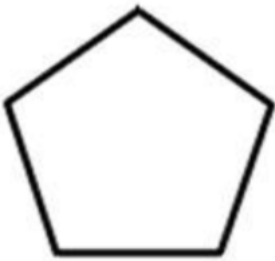

image not to scale

71) Assistent #92281 "92281 - 75986 - 75681 - 75679 - 75489 - 58264 - perimeter of the square"

What is the perimeter of the square with the given information?

7

11

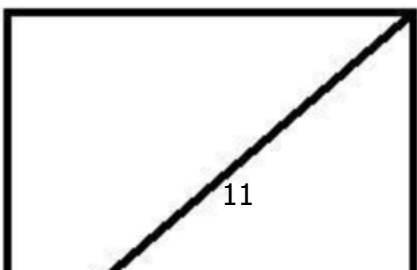



image not to scale

72) Assistent #92282 "92282 - 75986 - 75681 - 75679 - 75489 - 58264 - perimeter of the square"

What is the perimeter of the square with the given information?

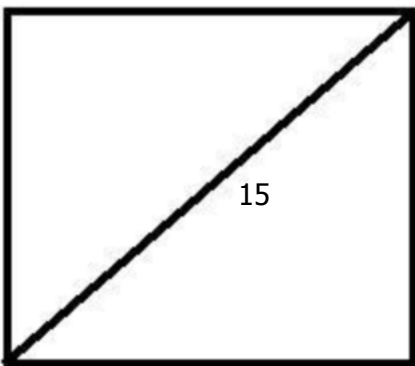

image not to scale

73) Assistent #92283 "92283 - 75986 - 75681 - 75679 - 75489 - 58264 - perimeter of the square"

What is the perimeter of the square with the given information?

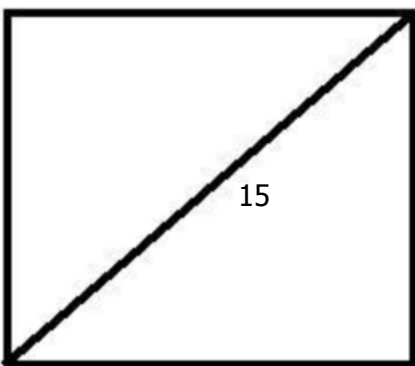

image not to scale

74) Assistent #92284 "92284 - 75986 - 75681 - 75679 - 75489 - 58264 - perimeter of the square"

What is the perimeter of the square with the given information?

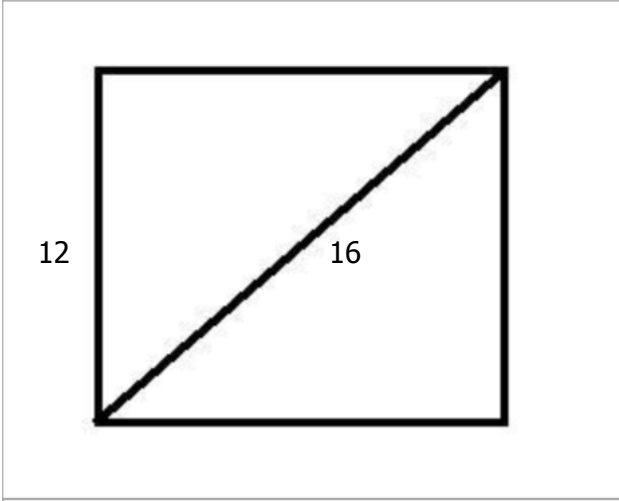

image not to scale

75) Assistent #92285 "92285 - 75986 - 75681 - 75679 - 75489 - 58264 - perimeter of the square"

What is the perimeter of the square with the given information?

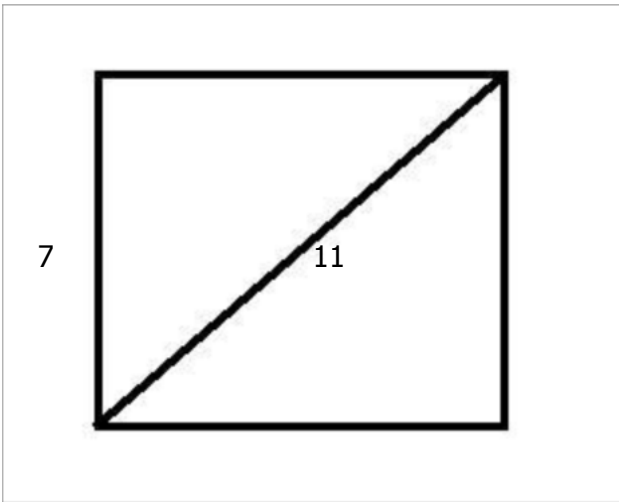

image not to scale

76) Assistent #92286 "92286 - 75986 - 75681 - 75679 - 75489 - 58264 - perimeter of the square"

What is the perimeter of the square with the given information?

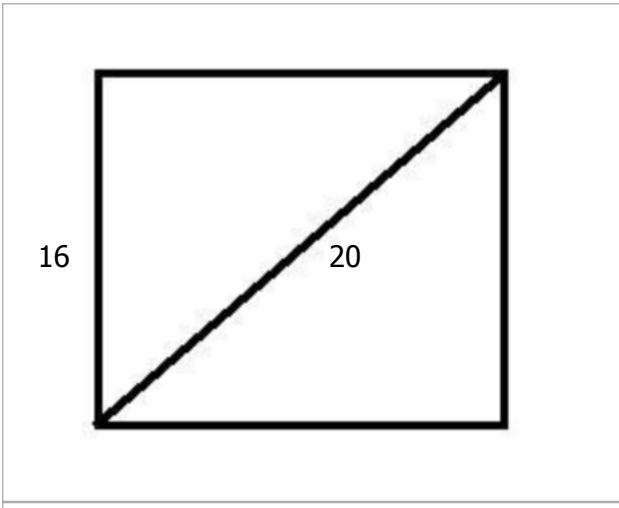

image not to scale

77) Assistent #92287 "92287 - 75986 - 75681 - 75679 - 75489 - 58264 - perimeter of the square"

What is the perimeter of the square with the given information?

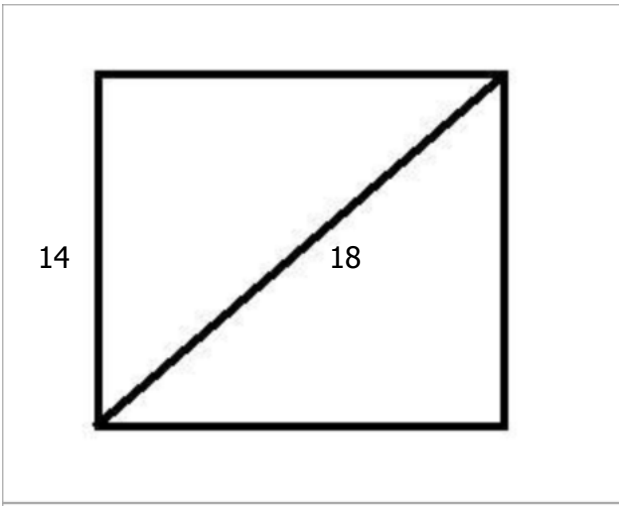

image not to scale

78) Assistent #92288 "92288 - 76091 - 76088 - 75988 - 75987 - Perimeter - regular polygon"

What is the perimeter of the follwing regular polygon with 5 sides?

8

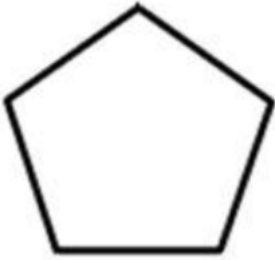

image not to scale

79) Assistent #92289 "92289 - 76091 - 76088 - 75988 - 75987 - Perimeter - regular polygon"

What is the perimeter of the follwing regular polygon with 5 sides?

9

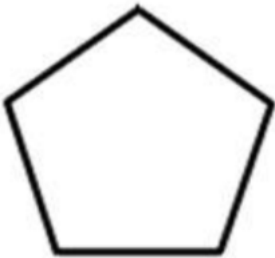

image not to scale

80) Assistent #92290 "92290 - 76091 - 76088 - 75988 - 75987 - Perimeter - regular polygon"

What is the perimeter of the follwing regular polygon with 5 sides?



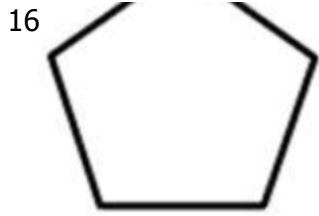

image not to scale

81) Assistent #92291 "92291 - 76091 - 76088 - 75988 - 75987 - Perimeter - regular polygon"

What is the perimeter of the follwing regular polygon with 5 sides?

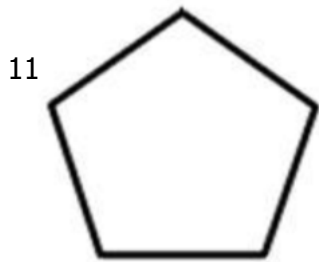

image not to scale

82) Assistent #92292 "92292 - 76091 - 76088 - 75988 - 75987 - Perimeter - regular polygon"

What is the perimeter of the follwing regular polygon with 5 sides?

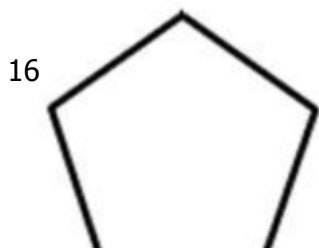



image not to scale

83) Assistent #92293 "92293 - 76091 - 76088 - 75988 - 75987 - Perimeter - regular polygon"

What is the perimeter of the follwing regular polygon with 5 sides?

13

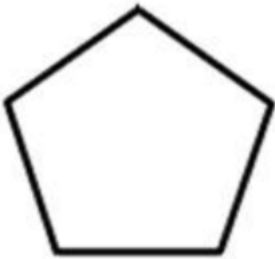

image not to scale

84) Assistent #92294 "92294 - 76091 - 76088 - 75988 - 75987 - Perimeter - regular polygon"

What is the perimeter of the follwing regular polygon with 5 sides?

10

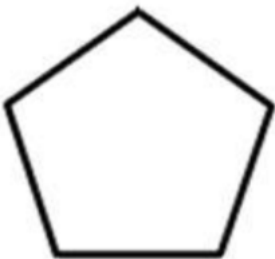

image not to scale

85) Assistent #92295 "92295 - 75987 - Perimeter - Square"

What is the perimeter of the square with the given information?

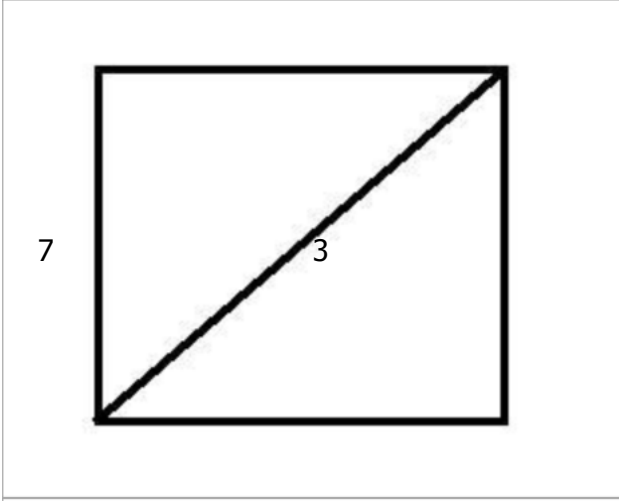

image not to scale

86) Assistent #92296 "92296 - 75987 - Perimeter - Square"

What is the perimeter of the square with the given information?

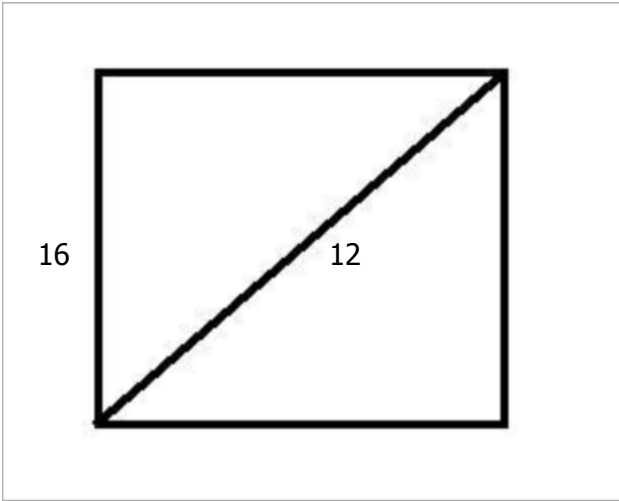

image not to scale

87) Assistent #92297 "92297 - 75987 - Perimeter - Square"

What is the perimeter of the square with the given information?

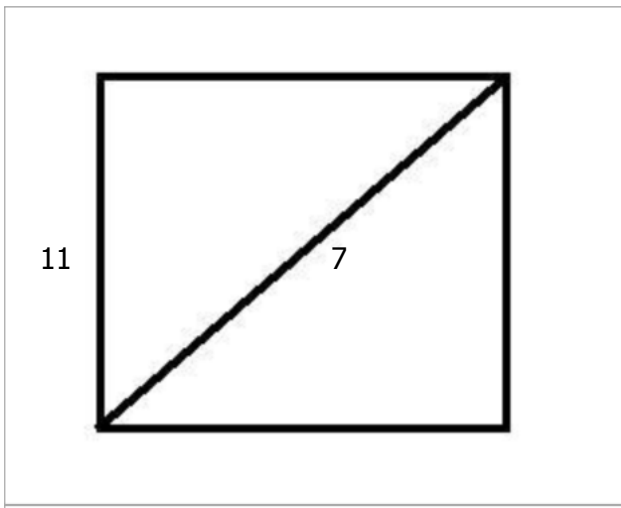

image not to scale

88) Assistent #92298 "92298 - 75987 - Perimeter - Square"

What is the perimeter of the square with the given information?

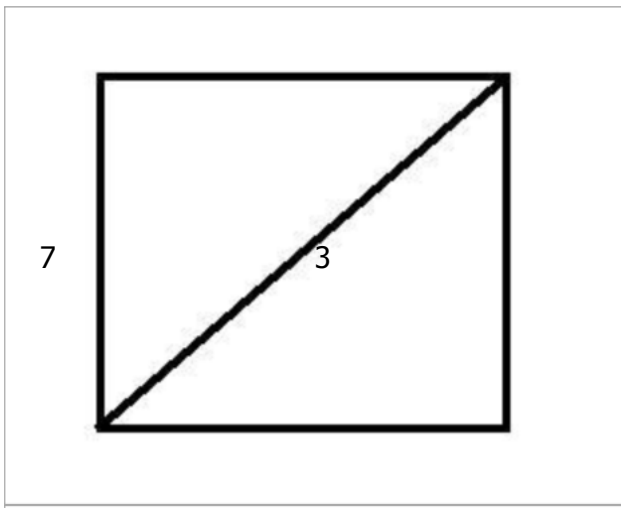
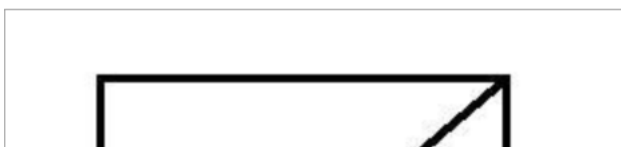

image not to scale

89) Assistent #92299 "92299 - 75987 - Perimeter - Square"

What is the perimeter of the square with the given information?



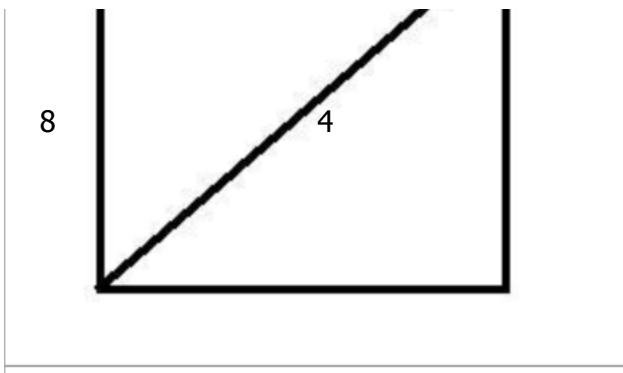

image not to scale

90) Assistent #92300 "92300 - 75987 - Perimeter - Square"

What is the perimeter of the square with the given information?

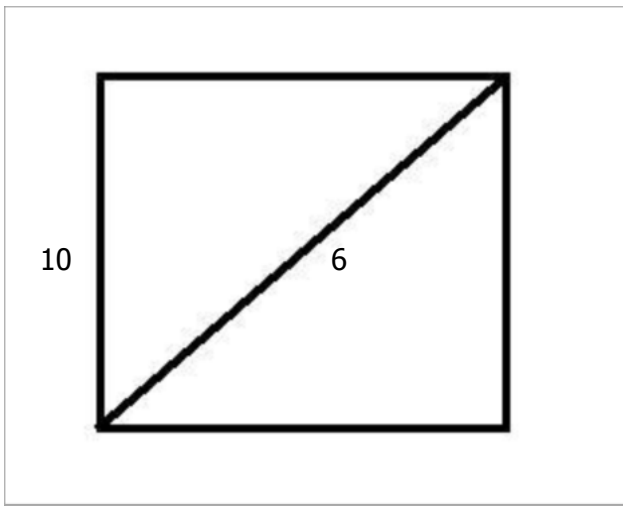

image not to scale

91) Assistent #92301 "92301 - 75987 - Perimeter - Square"

What is the perimeter of the square with the given information?

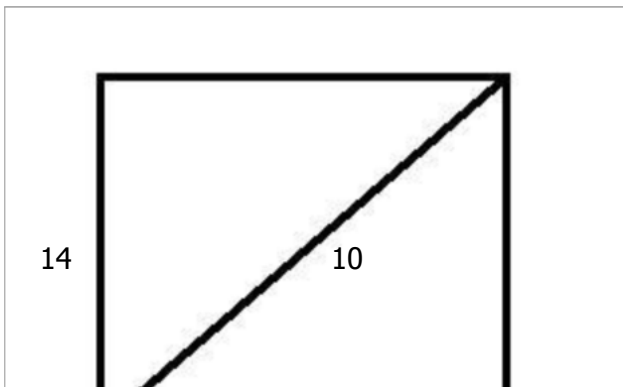



image not to scale

92) Assistent #92302 "92302 - 75679 - 75489 - 58264 - perimeter of the parallelogram"

What is the perimeter of the parallelogram the given information?

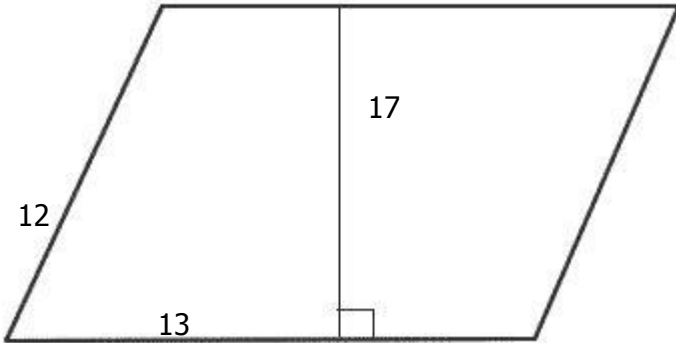

image not to scale

93) Assistent #92303 "92303 - 75679 - 75489 - 58264 - perimeter of the parallelogram"

What is the perimeter of the parallelogram the given information?

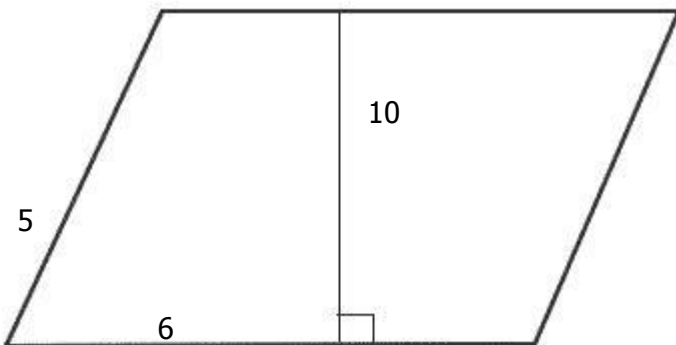

image not to scale

94) Assistent #92304 "92304 - 75679 - 75489 - 58264 - perimeter of the parallelogram"

What is the perimeter of the parallelogram the given information?

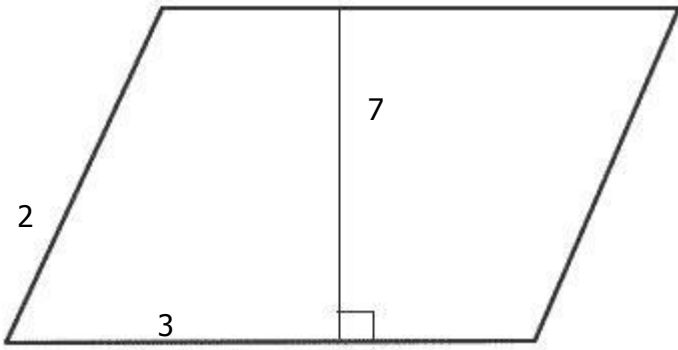

image not to scale

95) Assistent #92305 "92305 - 75679 - 75489 - 58264 - perimeter of the parallelogram"
What is the perimeter of the parallelogram the given information?

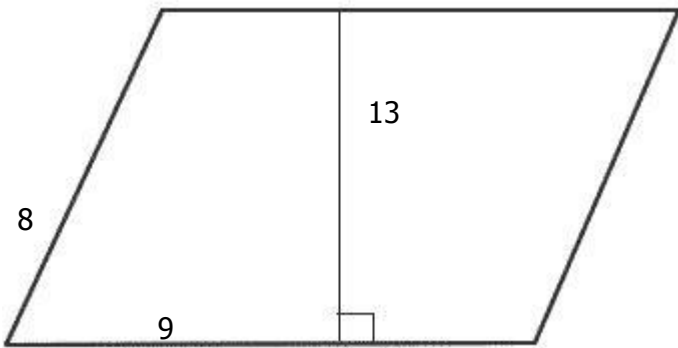

image not to scale

96) Assistent #92306 "92306 - 75679 - 75489 - 58264 - perimeter of the parallelogram"
What is the perimeter of the parallelogram the given information?

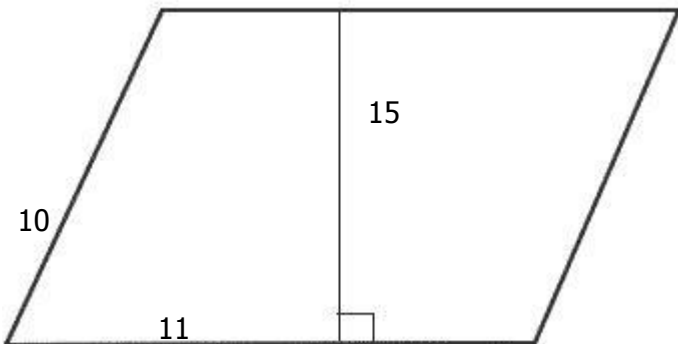

image not to scale

97) Assistent #92307 "92307 - 75679 - 75489 - 58264 - perimeter of the parallelogram"

What is the perimeter of the parallelogram the given information?

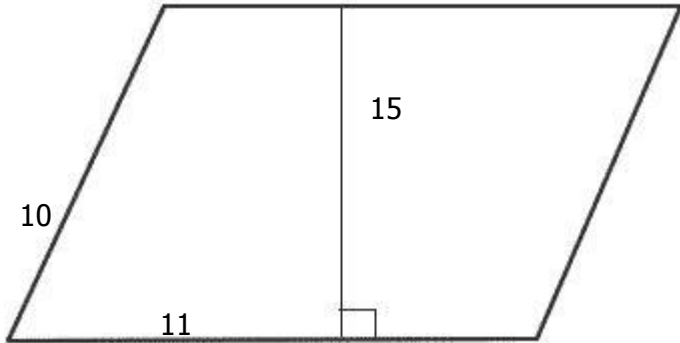

image not to scale

98) Assistent #92308 "92308 - 75679 - 75489 - 58264 - perimeter of the parallelogram"

What is the perimeter of the parallelogram the given information?

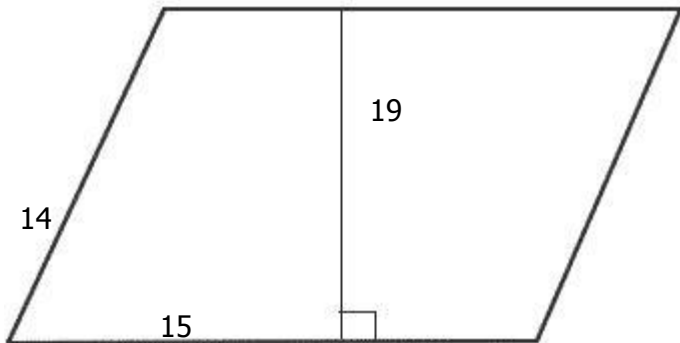

image not to scale

1) Assistent #91835 "91835 - 62271 - Area of the circle using radius"

What is the area of the circle with the radius of 7? (use 3.14 for π)

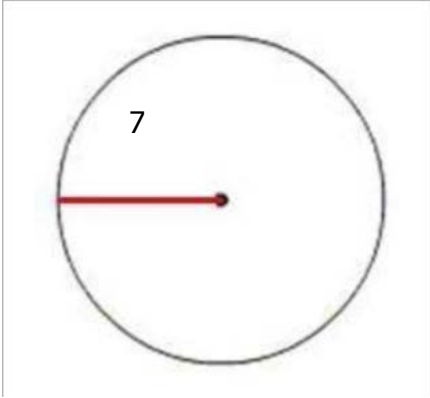

image not to scale

2) Assistent #91836 "91836 - 62271 - Area of the circle using radius"

What is the area of the circle with the radius of 11? (use 3.14 for π)

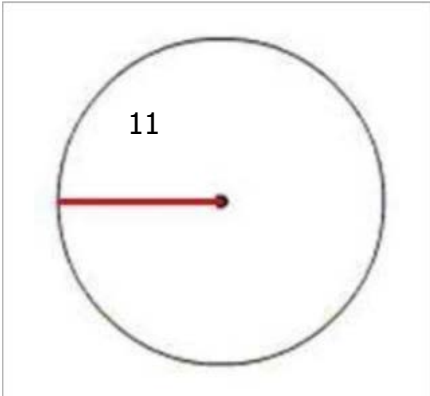

image not to scale

3) Assistent #91837 "91837 - 62271 - Area of the circle using radius"

What is the area of the circle with the radius of 9? (use 3.14 for π)

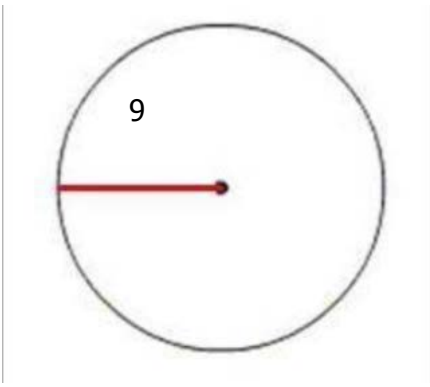

image not to scale

4) Assistent #91838 "91838 - 62271 - Area of the circle using radius"

What is the area of the circle with the radius of 6? (use 3.14 for π)

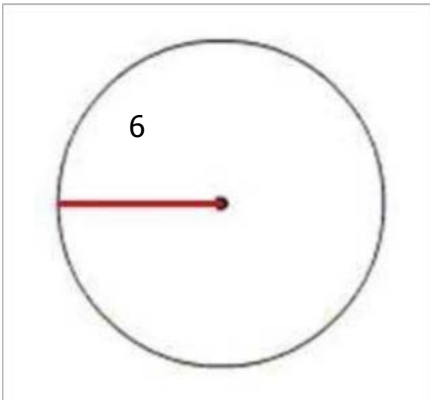

image not to scale

5) Assistent #91839 "91839 - 62271 - Area of the circle using radius"

What is the area of the circle with the radius of 7? (use 3.14 for π)

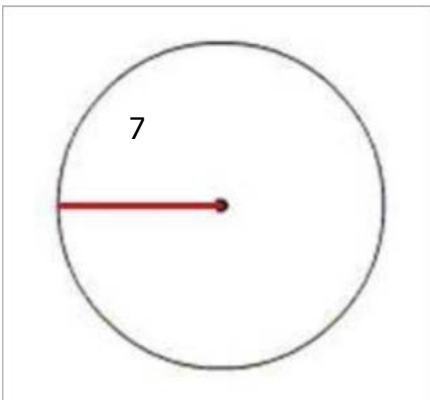

image not to scale

6) Assistent #91840 "91840 - 62271 - Area of the circle using radius"

What is the area of the circle with the radius of 9? (use 3.14 for π)

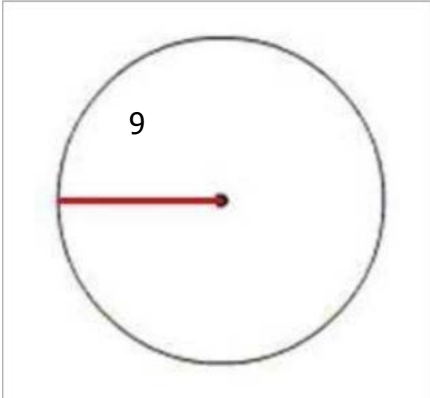

image not to scale

7) Assistent #91841 "91841 - 62271 - Area of the circle using radius"

What is the area of the circle with the radius of 10? (use 3.14 for π)

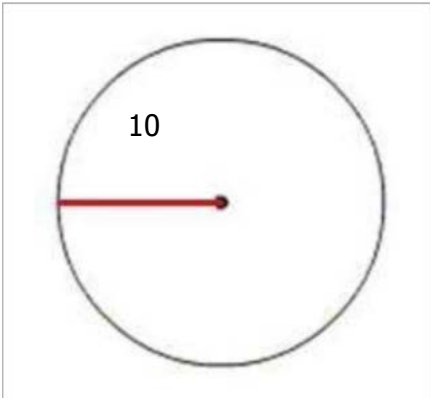

image not to scale

8) Assistent #91842 "91842 - 62271 - Area of the circle using radius"

What is the area of the circle with the radius of 6? (use 3.14 for π)

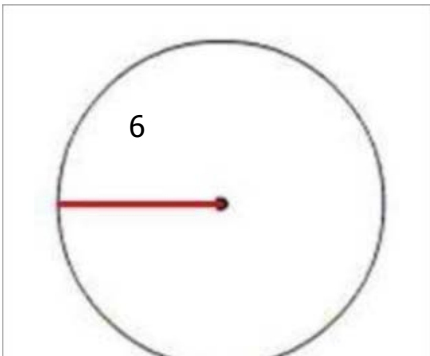

image not to scale

9) Assistent #91843 "91843 - 62271 - Area of the circle using radius"

What is the area of the circle with the radius of 7? (use 3.14 for π)

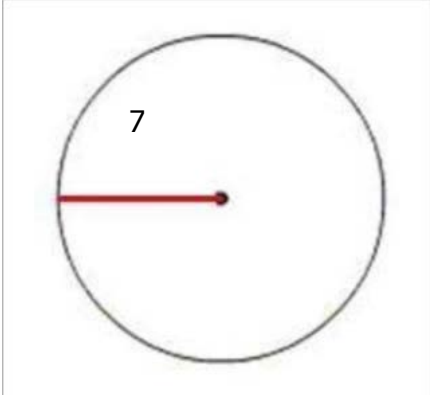

image not to scale

10) Assistent #91844 "91844 - 62271 - Area of the circle using radius"

What is the area of the circle with the radius of 8? (use 3.14 for π)

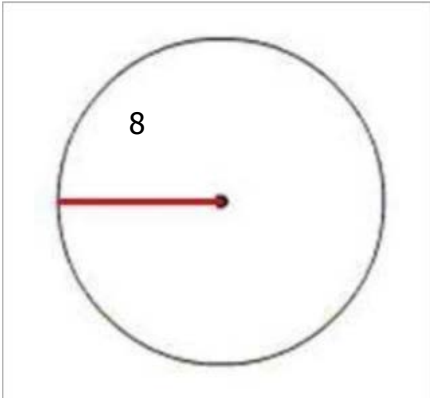
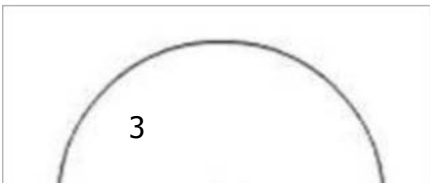

image not to scale

11) Assistent #91845 "91845 - 62271 - Area of the circle using radius"

What is the area of the circle with the radius of 3? (use 3.14 for π)



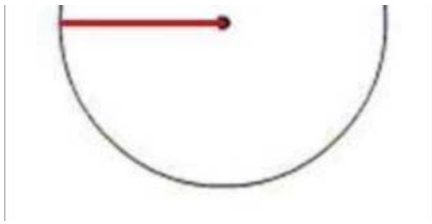

image not to scale

12) Assistent #91846 "91846 - 62271 - Area of the circle using radius"

What is the area of the circle with the radius of 8? (use 3.14 for π)

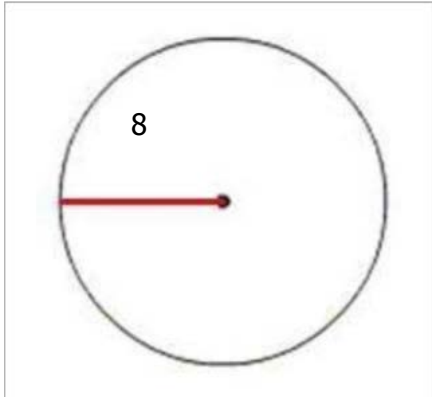

image not to scale

13) Assistent #91847 "91847 - 55956 - Diameter from area of circle"

What is the **diameter** of the circle when the area of the circle is **12.56**? (use 3.14 for π)

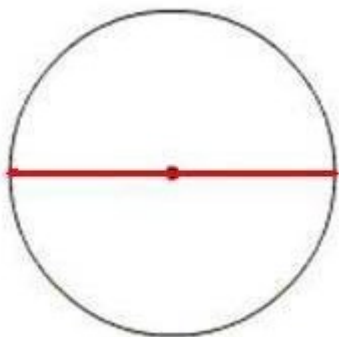

image not to scale

14) Assistent #91848 "91848 - 55956 - Diameter from area of circle"

What is the **diameter** of the circle when the area of the circle is **28.26**? (use 3.14 for π)

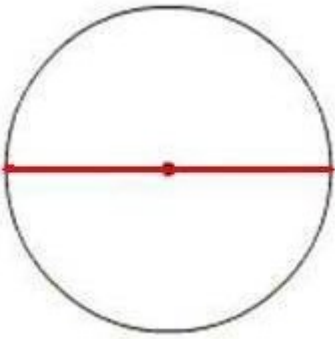

image not to scale

15) Assistent #91849 "91849 - 55956 - Diameter from area of circle"

What is the **diameter** of the circle when the area of the circle is **50.24**? (use 3.14 for π)

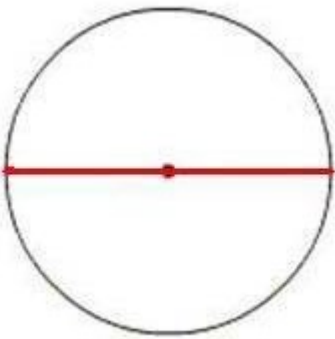

image not to scale

16) Assistent #91850 "91850 - 55956 - Diameter from area of circle"

What is the **diameter** of the circle when the area of the circle is **113.04**? (use 3.14 for π)

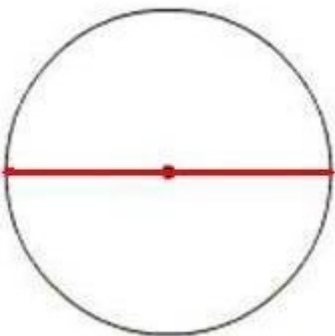

image not to scale

17) Assistent #91851 "91851 - 55956 - Diameter from area of circle"

What is the **diameter** of the circle when the area of the circle is **12.56**? (use 3.14 for π)

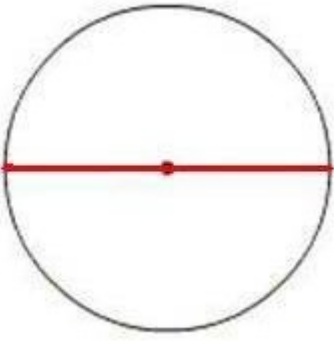

image not to scale

18) Assistent #91852 "91852 - 55956 - Diameter from area of circle"

What is the **diameter** of the circle when the area of the circle is **50.24**? (use 3.14 for π)

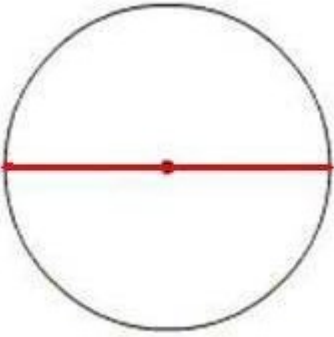

image not to scale

19) Assistent #91853 "91853 - 55956 - Diameter from area of circle"

What is the **diameter** of the circle when the area of the circle is **50.24**? (use 3.14 for π)

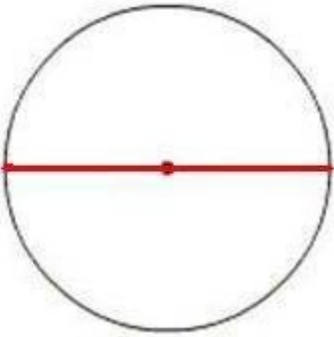

image not to scale

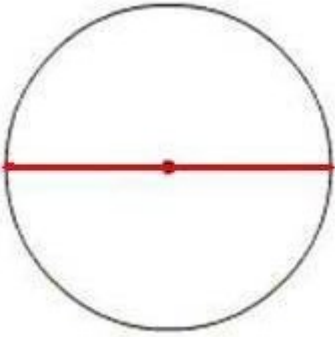

image not to scale

21) Assistent #91855 "91855 - 55956 - Diameter from area of circle"

What is the **diameter** of the circle when the area of the circle is **50.24**? (use 3.14 for π)

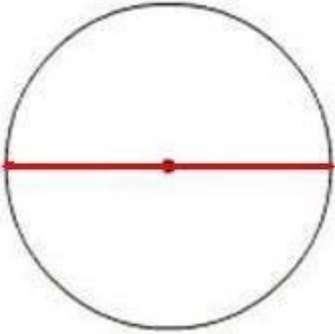

image not to scale

22) Assistent #91856 "91856 - 55956 - Diameter from area of circle"

What is the **diameter** of the circle when the area of the circle is **12.56**? (use 3.14 for π)

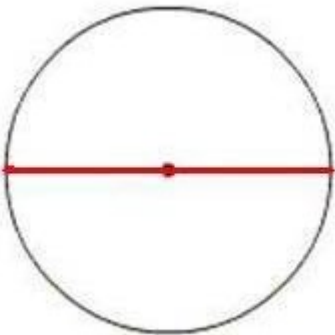

image not to scale

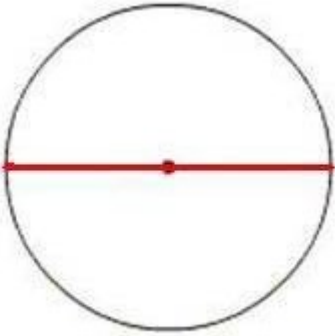

image not to scale

24) Assistent #91858 "91858 - 55956 - Diameter from area of circle"

What is the **diameter** of the circle when the area of the circle is **12.56**? (use 3.14 for π)

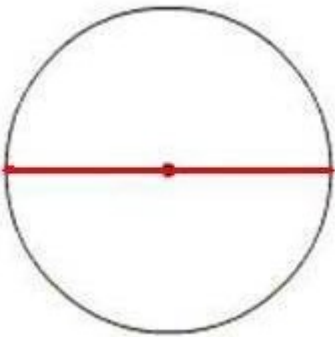

image not to scale

25) Assistent #91859 "91859 - Radius from area of circle"

What is the **radius** of the circle when the area of the circle is **113.04**? (use 3.14 for π)

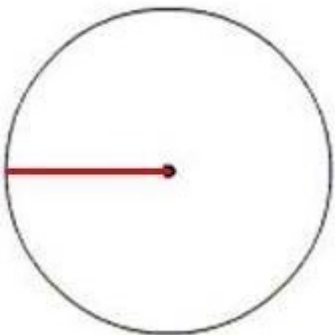

image not to scale

26) Assistent #91860 "91860 - Radius from area of circle"

What is the **radius** of the circle when the area of the circle is **78.5**? (use 3.14 for π)

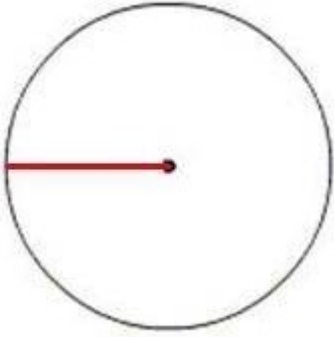

image not to scale

27) Assistent #91861 "91861 - Radius from area of circle"

What is the **radius** of the circle when the area of the circle is **78.5**? (use 3.14 for π)

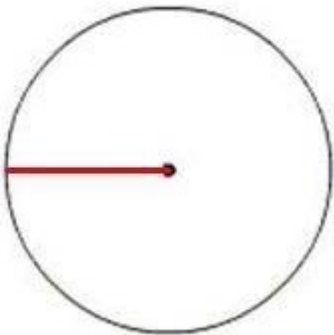

image not to scale

28) Assistent #91862 "91862 - Radius from area of circle"

What is the **radius** of the circle when the area of the circle is **50.24**? (use 3.14 for π)

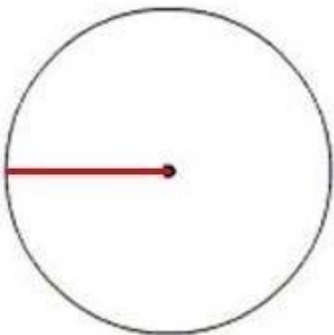

image not to scale

29) Assistent #91863 "91863 - Radius from area of circle"

What is the **radius** of the circle when the area of the circle is **50.24**? (use 3.14 for π)

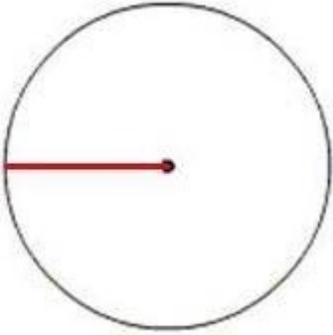

image not to scale

30) Assistent #91864 "91864 - Radius from area of circle"

What is the **radius** of the circle when the area of the circle is **12.56**? (use 3.14 for π)

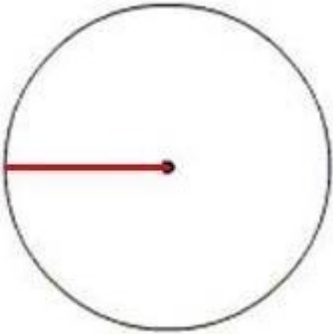

image not to scale

31) Assistent #91865 "91865 - Radius from area of circle"

What is the **radius** of the circle when the area of the circle is **50.24**? (use 3.14 for π)

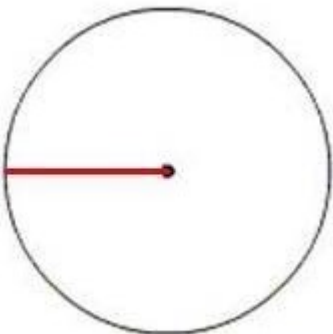

image not to scale

32) Assistent #91866 "91866 - Radius from area of circle"

What is the **radius** of the circle when the area of the circle is **28.26**? (use 3.14 for π)

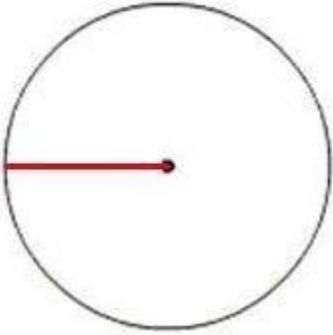

image not to scale

33) Assistent #91867 "91867 - Radius from area of circle"

What is the **radius** of the circle when the area of the circle is **50.24**? (use 3.14 for π)

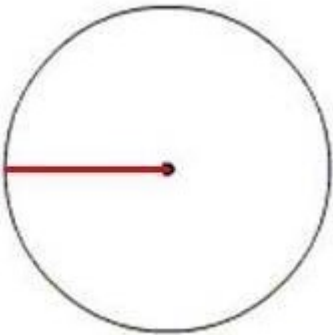

image not to scale

34) Assistent #91868 "91868 - Radius from area of circle"

What is the **radius** of the circle when the area of the circle is **78.5**? (use 3.14 for π)

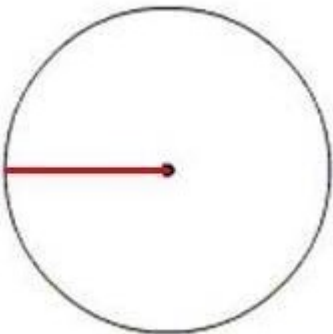

image not to scale

35) Assistent #91869 "91869 - Radius from area of circle"

What is the **radius** of the circle when the area of the circle is **50.24**? (use 3.14 for π)

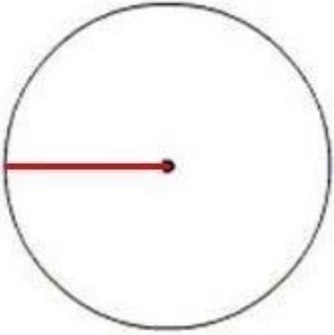

image not to scale

36) Assistent #91870 "91870 - Radius from area of circle"

What is the **radius** of the circle when the area of the circle is **28.26**? (use 3.14 for π)

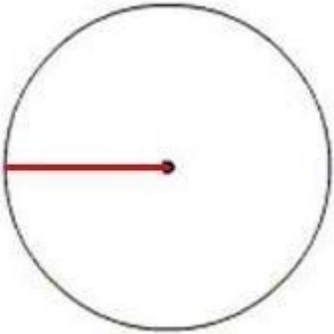

image not to scale

37) Assistent #91871 "91871 - 55937 - Area of circle using diameter"

What is the area of the circle with the diameter of 8? (use 3.14 for π)

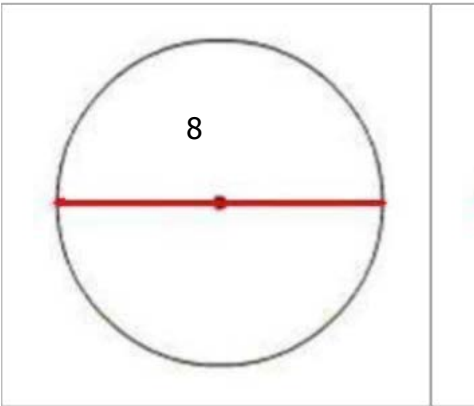

image not to scale

38) Assistent #91872 "91872 - 55937 - Area of circle using diameter"

What is the area of the circle with the diameter of 6? (use 3.14 for π)

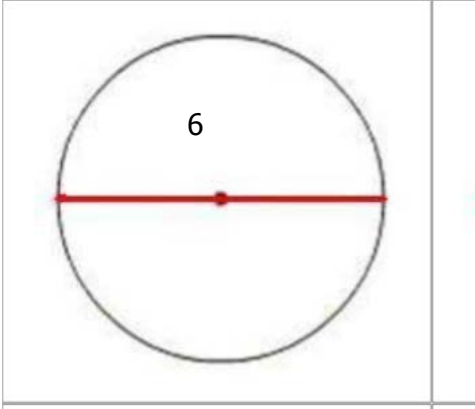

image not to scale

39) Assistent #91873 "91873 - 55937 - Area of circle using diameter"

What is the area of the circle with the diameter of 5? (use 3.14 for π)

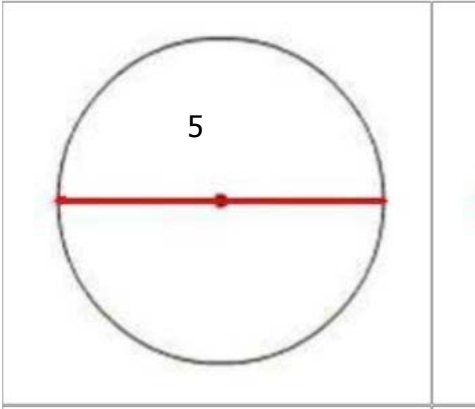

image not to scale

40) Assistent #91874 "91874 - 55937 - Area of circle using diameter"

What is the area of the circle with the diameter of 4? (use 3.14 for π)

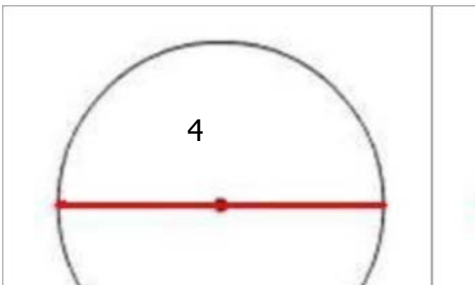



image not to scale

41) Assistent #91875 "91875 - 55937 - Area of circle using diameter"

What is the area of the circle with the diameter of 5? (use 3.14 for π)

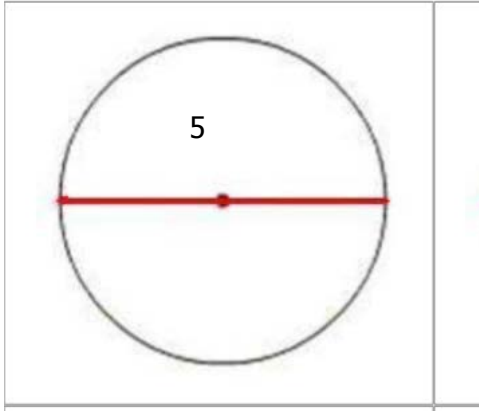

image not to scale

42) Assistent #91876 "91876 - 55937 - Area of circle using diameter"

What is the area of the circle with the diameter of 9? (use 3.14 for π)

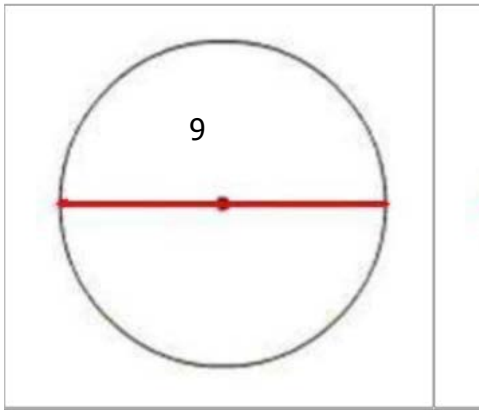
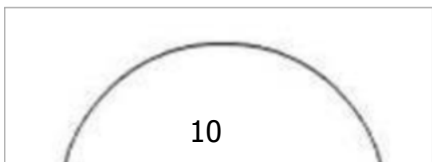

image not to scale

43) Assistent #91877 "91877 - 55937 - Area of circle using diameter"

What is the area of the circle with the diameter of 10? (use 3.14 for π)



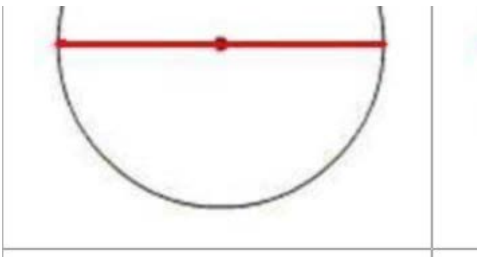

image not to scale

44) Assistentment #91878 "91878 - 55937 - Area of circle using diameter"

What is the area of the circle with the diameter of 8? (use 3.14 for π)

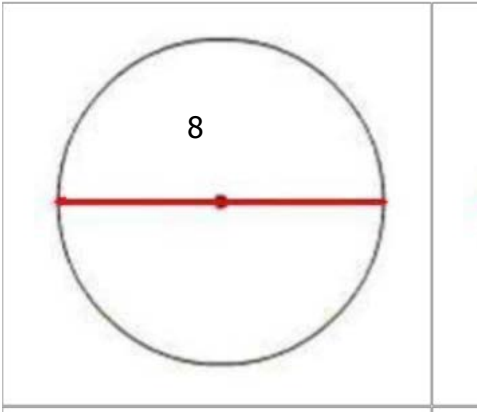

image not to scale

45) Assistentment #91879 "91879 - 55937 - Area of circle using diameter"

What is the area of the circle with the diameter of 6? (use 3.14 for π)

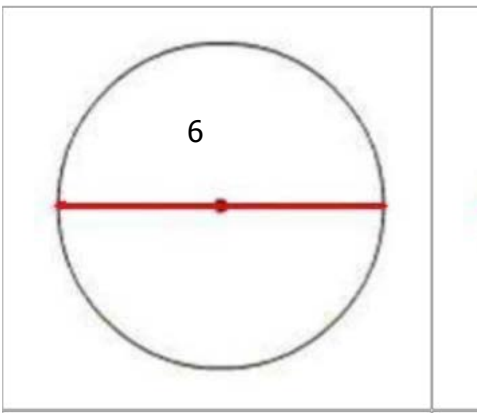

image not to scale

46) Assistentment #91880 "91880 - 55937 - Area of circle using diameter"

What is the area of the circle with the diameter of 6? (use 3.14 for π)

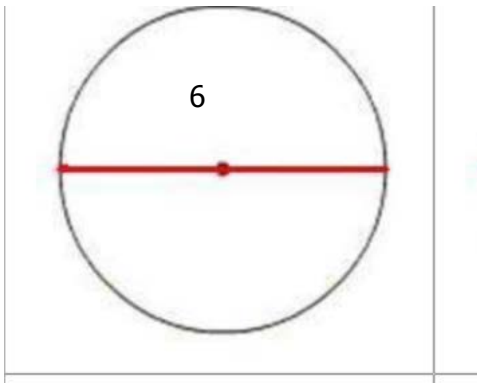

image not to scale

47) Assistent #91881 "91881 - 55937 - Area of circle using diameter"

What is the area of the circle with the diameter of 8? (use 3.14 for π)

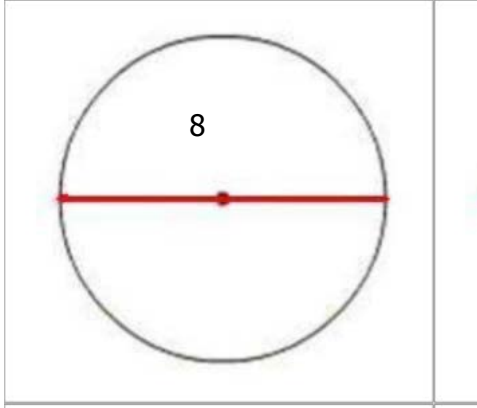

image not to scale

48) Assistent #91882 "91882 - 55937 - Area of circle using diameter"

What is the area of the circle with the diameter of 9? (use 3.14 for π)

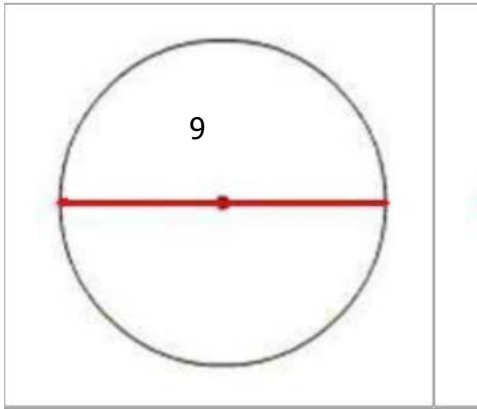

image not to scale

49) Assistent #91883 "91883 - 62273 - 55937 - Area of circle using diameter"

What is the area of the circle with the diameter of 8? (use 3.14 for π)

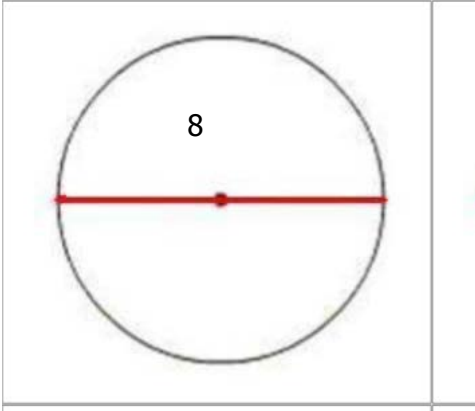

image not to scale

50) Assistent #91884 "91884 - 62273 - 55937 - Area of circle using diameter"

What is the area of the circle with the diameter of 9? (use 3.14 for π)

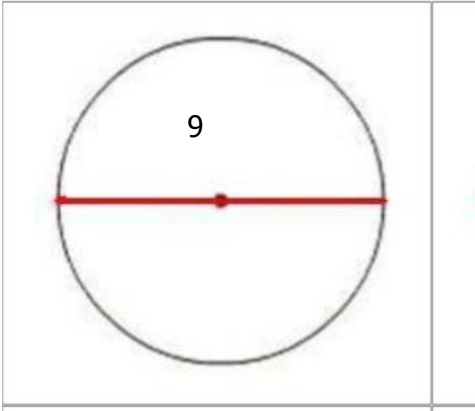

image not to scale

51) Assistent #91885 "91885 - 62273 - 55937 - Area of circle using diameter"

What is the area of the circle with the diameter of 6? (use 3.14 for π)

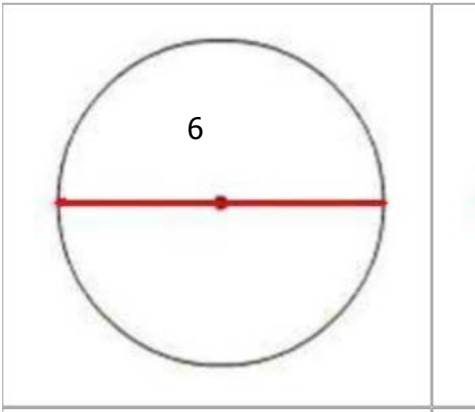

image not to scale

52) Assistent #91886 "91886 - 62273 - 55937 - Area of circle using diameter"

What is the area of the circle with the diameter of 9? (use 3.14 for π)

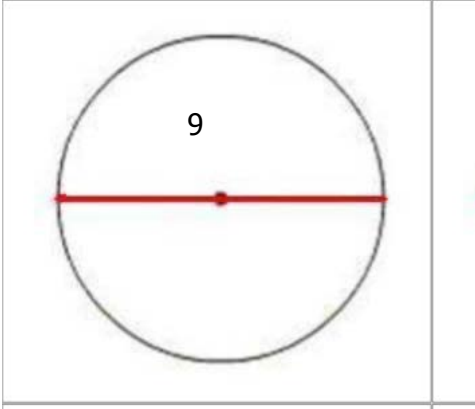

image not to scale

53) Assistent #91887 "91887 - 62273 - 55937 - Area of circle using diameter"

What is the area of the circle with the diameter of 7? (use 3.14 for π)

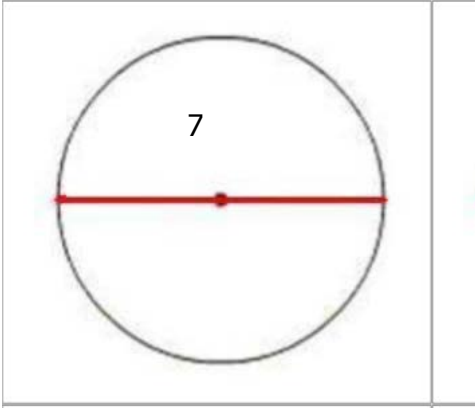

image not to scale

54) Assistent #91888 "91888 - 62273 - 55937 - Area of circle using diameter"

What is the area of the circle with the diameter of 4? (use 3.14 for π)

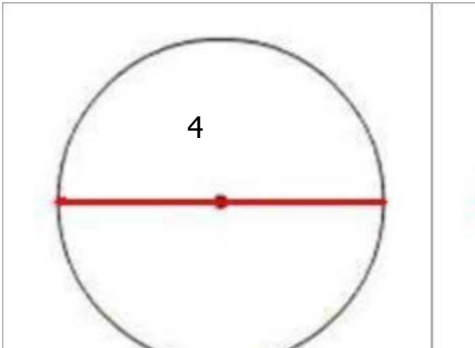



image not to scale

55) Assistent #91889 "91889 - 62273 - 55937 - Area of circle using diameter"

What is the area of the circle with the diameter of 5? (use 3.14 for π)

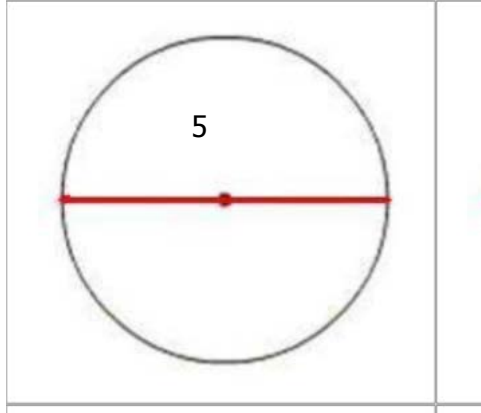

image not to scale

56) Assistent #91890 "91890 - 62273 - 55937 - Area of circle using diameter"

What is the area of the circle with the diameter of 8? (use 3.14 for π)

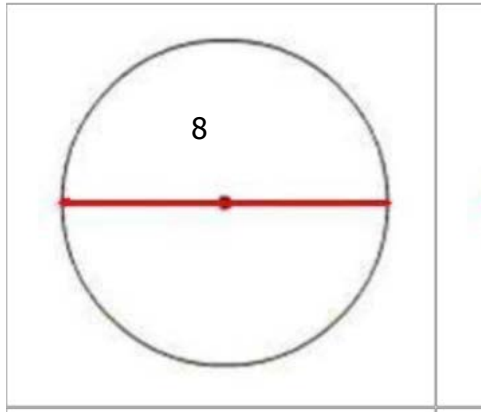

image not to scale

57) Assistent #91891 "91891 - 62273 - 55937 - Area of circle using diameter"

What is the area of the circle with the diameter of 10? (use 3.14 for π)

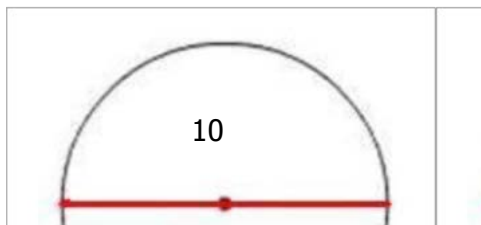



image not to scale

58) Assistent #91892 "91892 - 62273 - 55937 - Area of circle using diameter"

What is the area of the circle with the diameter of 9? (use 3.14 for π)

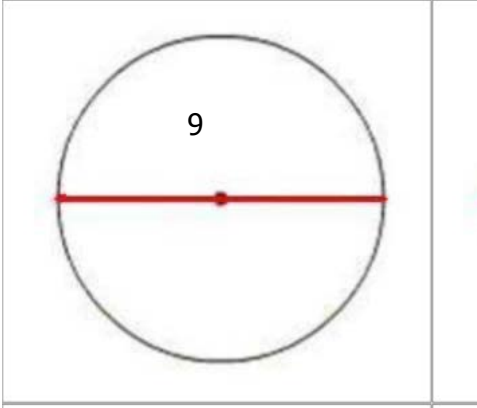

image not to scale

59) Assistent #91893 "91893 - 62273 - 55937 - Area of circle using diameter"

What is the area of the circle with the diameter of 7? (use 3.14 for π)

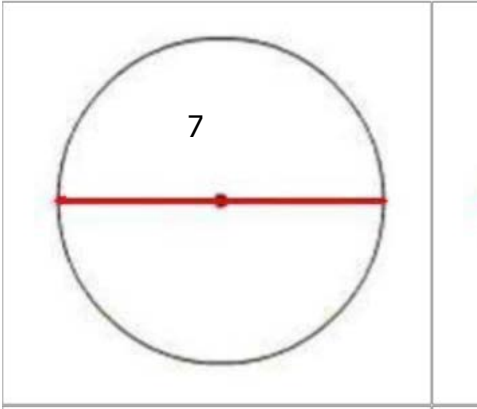

image not to scale

60) Assistent #91894 "91894 - 62273 - 55937 - Area of circle using diameter"

What is the area of the circle with the diameter of 10? (use 3.14 for π)



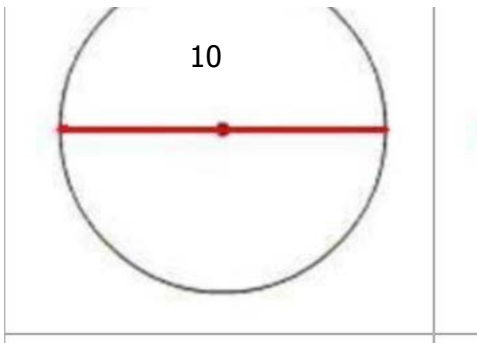

image not to scale

61) Assistent #91895 "91895 - 55910 - Area of the circle using radius"

What is the area of the circle with the radius of 2? (use 3.14 for π)

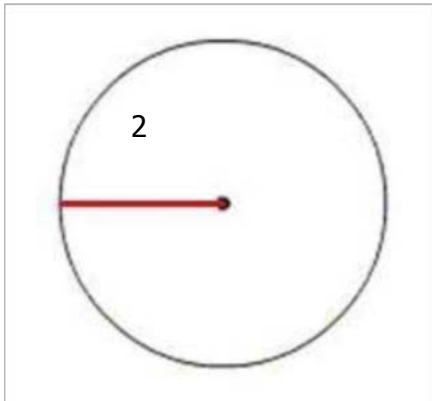

image not to scale

62) Assistent #91896 "91896 - 55910 - Area of the circle using radius"

What is the area of the circle with the radius of 11? (use 3.14 for π)

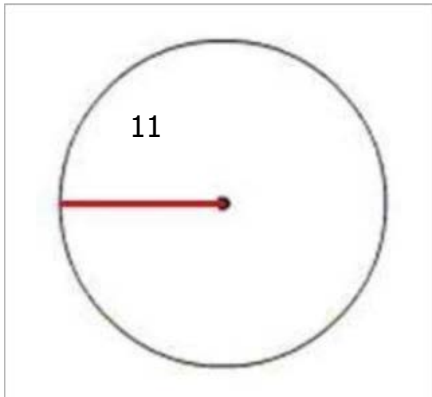

image not to scale

63) Assistent #91897 "91897 - 55910 - Area of the circle using radius"

What is the area of the circle with the radius of 4? (use 3.14 for π)

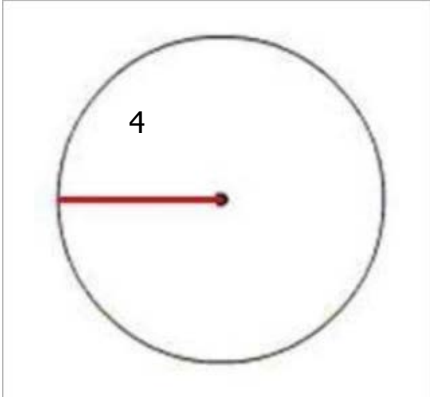

image not to scale

64) Assisment #91898 "91898 - 55910 - Area of the circle using radius"

What is the area of the circle with the radius of 11? (use 3.14 for π)

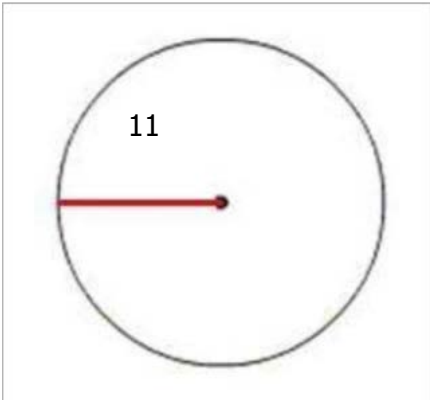

image not to scale

65) Assisment #91899 "91899 - 55910 - Area of the circle using radius"

What is the area of the circle with the radius of 6? (use 3.14 for π)

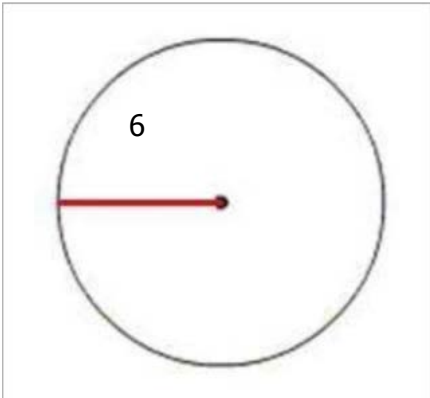

image not to scale

66) Assistent #91900 "91900 - 55910 - Area of the circle using radius"

What is the area of the circle with the radius of 2? (use 3.14 for π)

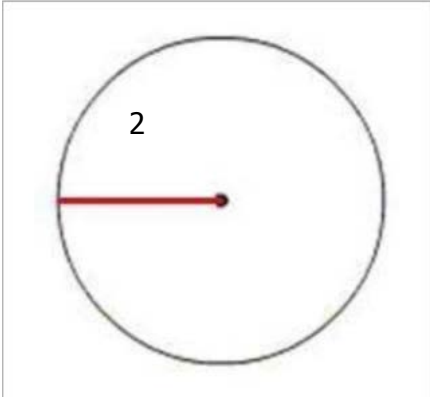

image not to scale

67) Assistent #91901 "91901 - 55910 - Area of the circle using radius"

What is the area of the circle with the radius of 9? (use 3.14 for π)

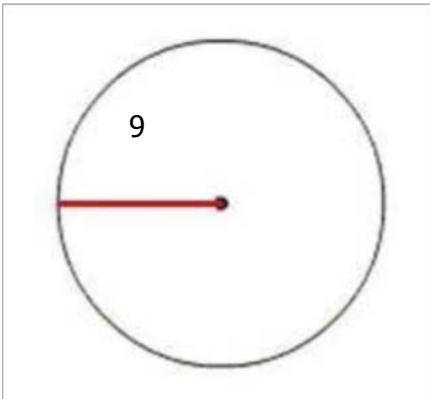

image not to scale

68) Assistent #91902 "91902 - 55910 - Area of the circle using radius"

What is the area of the circle with the radius of 6? (use 3.14 for π)

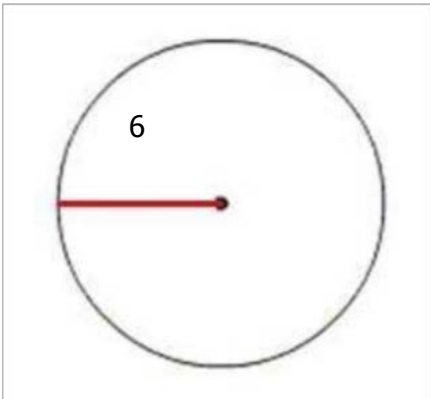

image not to scale

69) Assisment #91903 "91903 - 55910 - Area of the circle using radius"

What is the area of the circle with the radius of 4? (use 3.14 for π)

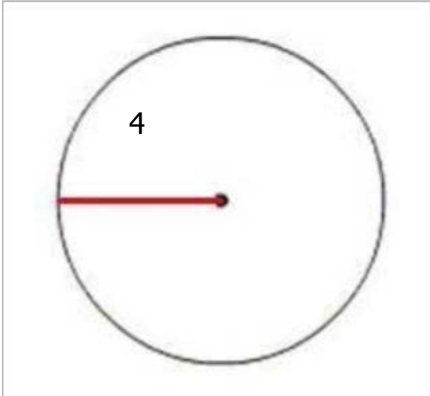

image not to scale

70) Assisment #91904 "91904 - 55910 - Area of the circle using radius"

What is the area of the circle with the radius of 9? (use 3.14 for π)

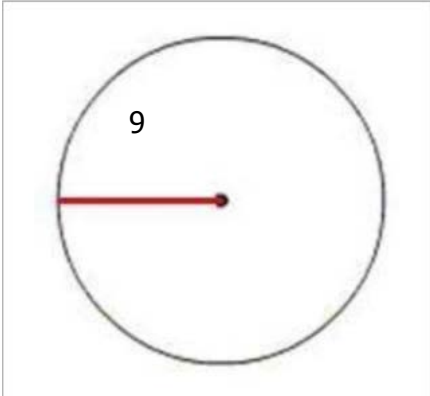

image not to scale

71) Assisment #91905 "91905 - 55910 - Area of the circle using radius"

What is the area of the circle with the radius of 7? (use 3.14 for π)

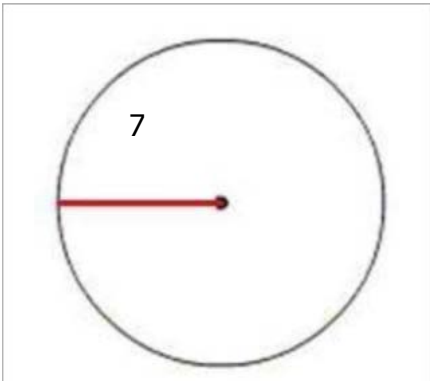

image not to scale

72) Assistent #91906 "91906 - 55910 - Area of the circle using radius"

What is the area of the circle with the radius of 6? (use 3.14 for π)

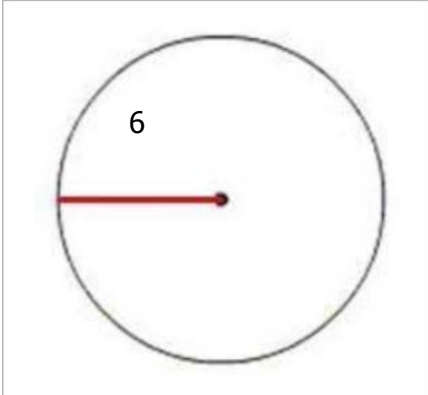

image not to scale

73) Assistent #91907 "91907 - Radius from area of circle"

What is the **radius** of the circle when the area of the circle is **28.26**? (use 3.14 for π)

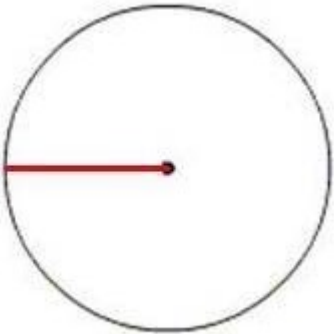

image not to scale

74) Assistent #91908 "91908 - Radius from area of circle"

What is the **radius** of the circle when the area of the circle is **12.56**? (use 3.14 for π)

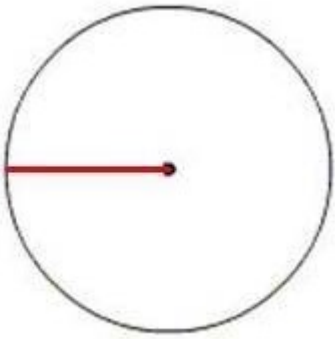

image not to scale

75) Assistent #91909 "91909 - Radius from area of circle"

What is the **radius** of the circle when the area of the circle is **28.26**? (use 3.14 for π)

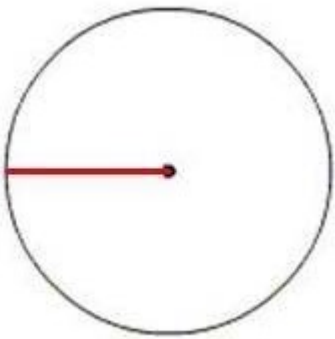

image not to scale

76) Assistent #91910 "91910 - Radius from area of circle"

What is the **radius** of the circle when the area of the circle is **12.56**? (use 3.14 for π)

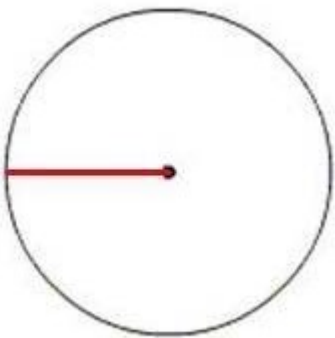

image not to scale

77) Assistent #91911 "91911 - Radius from area of circle"

What is the **radius** of the circle when the area of the circle is **113.04**? (use 3.14 for π)

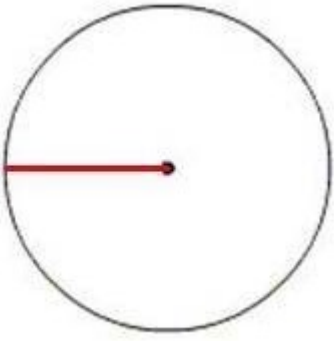

image not to scale

78) Assistent #91912 "91912 - Radius from area of circle"

What is the **radius** of the circle when the area of the circle is **28.26**? (use 3.14 for π)

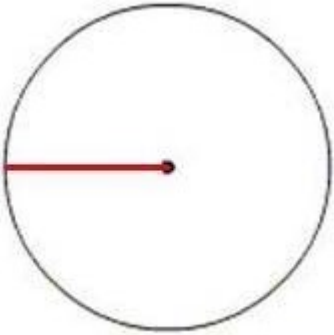

image not to scale

79) Assistent #91913 "91913 - Radius from area of circle"

What is the **radius** of the circle when the area of the circle is **113.04**? (use 3.14 for π)

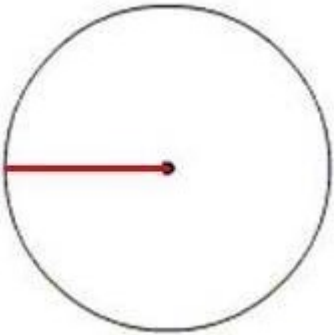

image not to scale

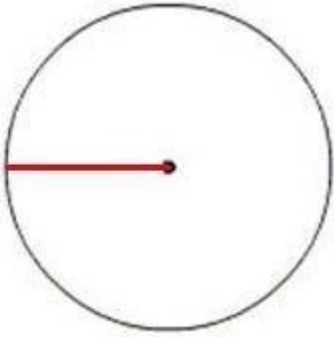

image not to scale

81) Assistent #91915 "91915 - Radius from area of circle"

What is the **radius** of the circle when the area of the circle is **28.26**? (use 3.14 for π)

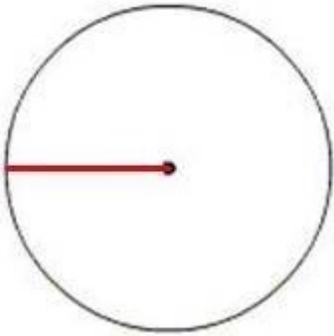

image not to scale

82) Assistent #91916 "91916 - Radius from area of circle"

What is the **radius** of the circle when the area of the circle is **50.24**? (use 3.14 for π)

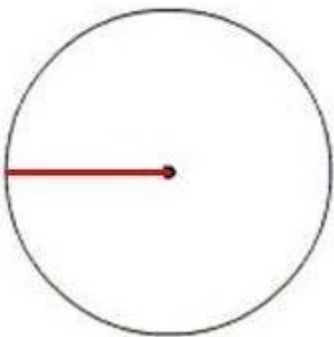

image not to scale

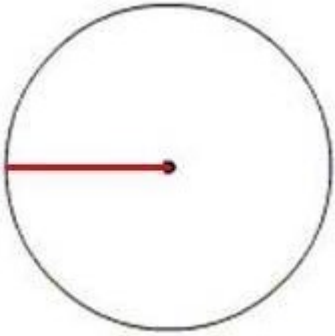

image not to scale

84) Assistent #91918 "91918 - Radius from area of circle"

What is the **radius** of the circle when the area of the circle is **78.5**? (use 3.14 for π)

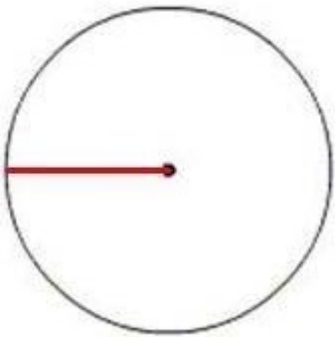

image not to scale

85) Assistent #91919 "91919 - 55956 - Diameter from area of circle"

What is the **diameter** of the circle when the area of the circle is **50.24**? (use 3.14 for π)

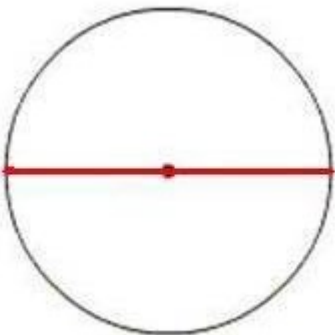

image not to scale

86) Assistent #91920 "91920 - 55956 - Diameter from area of circle"

What is the **diameter** of the circle when the area of the circle is **113.04**? (use 3.14 for π)

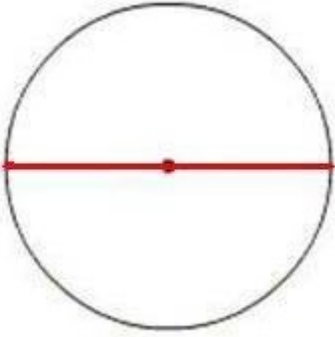

image not to scale

87) Assistent #91921 "91921 - 55956 - Diameter from area of circle"

What is the **diameter** of the circle when the area of the circle is **78.5**? (use 3.14 for π)

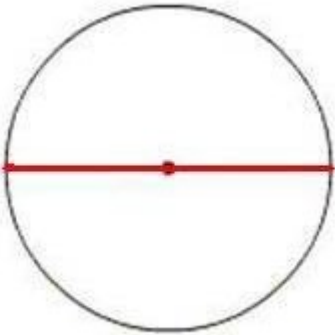

image not to scale

88) Assistent #91922 "91922 - 55956 - Diameter from area of circle"

What is the **diameter** of the circle when the area of the circle is **113.04**? (use 3.14 for π)

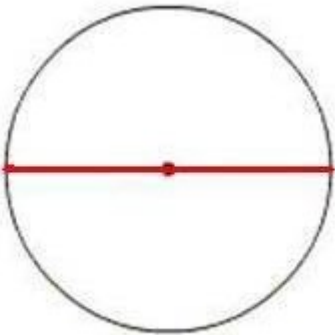

image not to scale

89) Assistent #91923 "91923 - 55956 - Diameter from area of circle"

What is the **diameter** of the circle when the area of the circle is **50.24**? (use 3.14 for π)

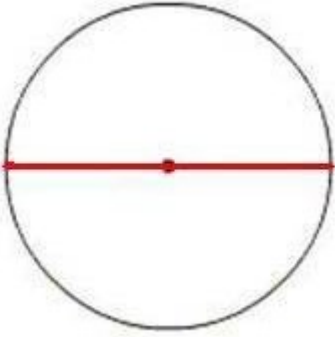

image not to scale

90) Assistent #91924 "91924 - 55956 - Diameter from area of circle"

What is the **diameter** of the circle when the area of the circle is **50.24**? (use 3.14 for π)

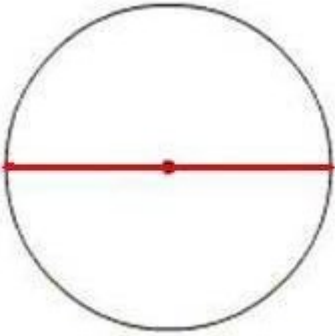

image not to scale

91) Assistent #91925 "91925 - 55956 - Diameter from area of circle"

What is the **diameter** of the circle when the area of the circle is **78.5**? (use 3.14 for π)

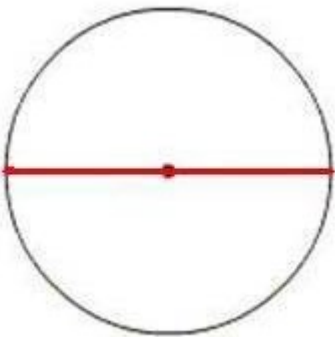

image not to scale

92) Assistent #91926 "91926 - 55956 - Diameter from area of circle"

What is the **diameter** of the circle when the area of the circle is **78.5**? (use 3.14 for π)

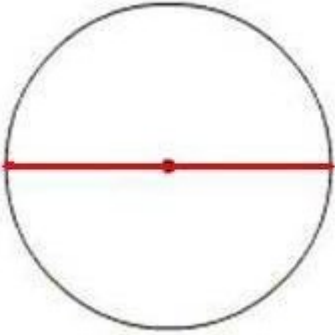

image not to scale

93) Assistent #91927 "91927 - 55956 - Diameter from area of circle"

What is the **diameter** of the circle when the area of the circle is **50.24**? (use 3.14 for π)

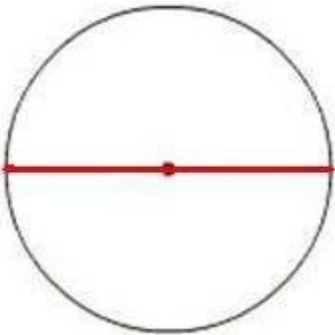

image not to scale

94) Assistent #91928 "91928 - 55956 - Diameter from area of circle"

What is the **diameter** of the circle when the area of the circle is **50.24**? (use 3.14 for π)

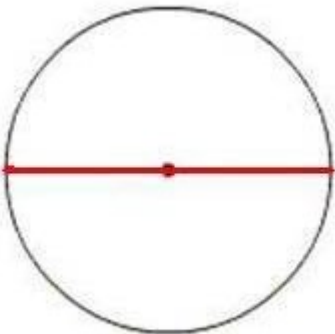

image not to scale

95) Assistent #91929 "91929 - 55956 - Diameter from area of circle"

What is the **diameter** of the circle when the area of the circle is **78.5**? (use 3.14 for π)

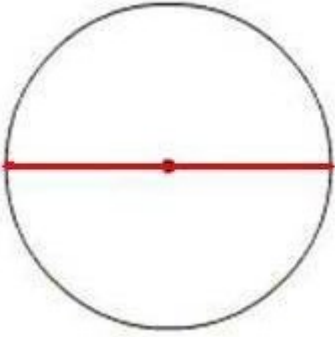

image not to scale

96) Assistent #91930 "91930 - 55956 - Diameter from area of circle"

What is the **diameter** of the circle when the area of the circle is **50.24**? (use 3.14 for π)

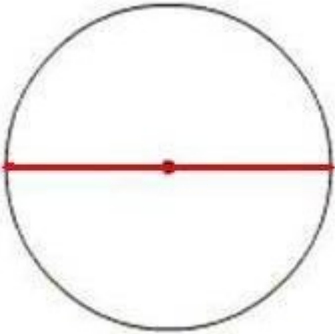

image not to scale

1) Assistent #91931 "91931 - 57350 - Superimposed circle areas with radius"

The outer circle has a radius of 12 and inner circle has a radius of 7. What is the area of the shaded region? Use 3.14 for π .

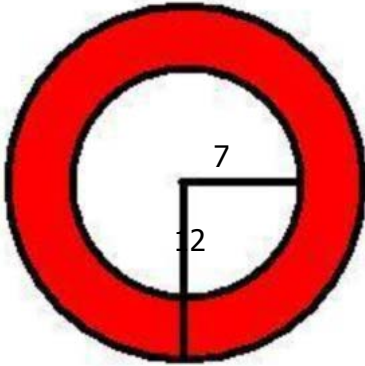

image not to scale

2) Assistent #91932 "91932 - 57350 - Superimposed circle areas with radius"

The outer circle has a radius of 9 and inner circle has a radius of 4. What is the area of the shaded region? Use 3.14 for π .

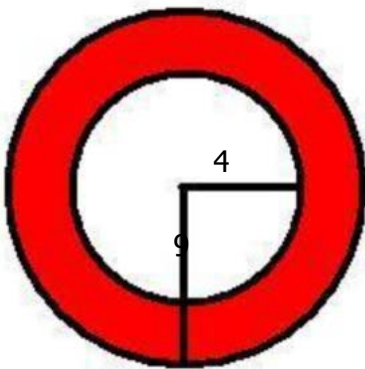

image not to scale

3) Assistent #91933 "91933 - 57350 - Superimposed circle areas with radius"

The outer circle has a radius of 10 and inner circle has a radius of 5. What is the area of the shaded region? Use 3.14 for π .

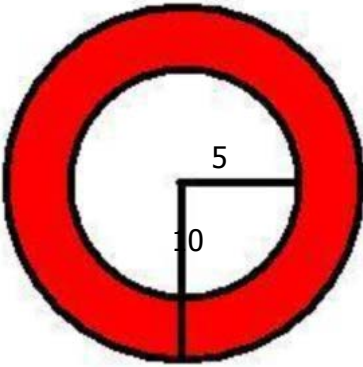

image not to scale

4) Assistent #91934 "91934 - 57350 - Superimposed circle areas with radius"

The outer circle has a radius of 11 and inner circle has a radius of 6. What is the area of the shaded region? Use 3.14 for π .

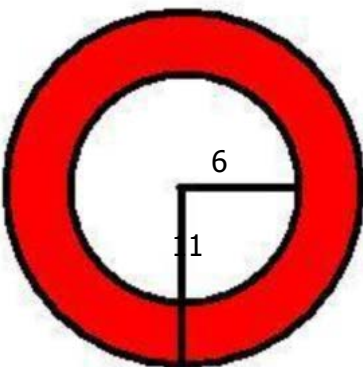

image not to scale

5) Assistentment #91935 "91935 - 57350 - Superimposed circle areas with radius"

The outer circle has a radius of 11 and inner circle has a radius of 6. What is the area of the shaded region? Use 3.14 for π .

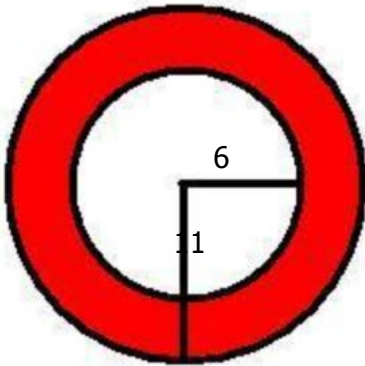

image not to scale

6) Assistentment #91936 "91936 - 57350 - Superimposed circle areas with radius"

The outer circle has a radius of 10 and inner circle has a radius of 5. What is the area of the shaded region? Use 3.14 for π .

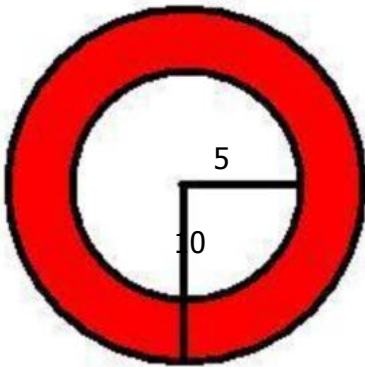

image not to scale

7) Assistentment #91937 "91937 - 57350 - Superimposed circle areas with radius"

The outer circle has a radius of 8 and inner circle has a radius of 3. What is the area of the shaded region? Use 3.14 for π .



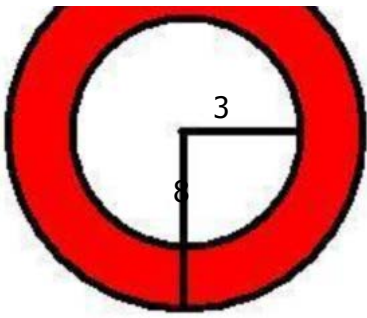

image not to scale

8) Assistentment #91938 "91938 - 57350 - Superimposed circle areas with radius"

The outer circle has a radius of 9 and inner circle has a radius of 4. What is the area of the shaded region? Use 3.14 for π .

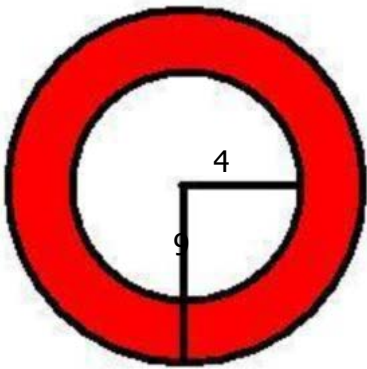

image not to scale

9) Assistentment #91939 "91939 - 65824- area of shade square circle"

What is the area of the shaded region in the figure below? (Use 3.14 for π)

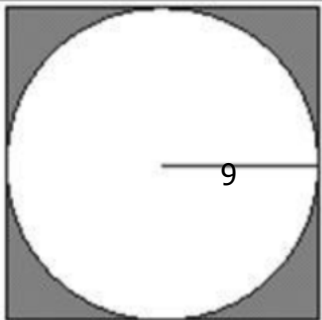

image not to scale

10) Assistent #91940 "91940 - 65824- area of shade square circle"

What is the area of the shaded region in the figure below? (Use 3.14 for π)

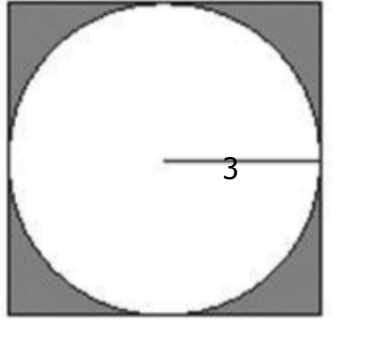

image not to scale

11) Assistent #91941 "91941 - 65824- area of shade square circle"

What is the area of the shaded region in the figure below? (Use 3.14 for π)

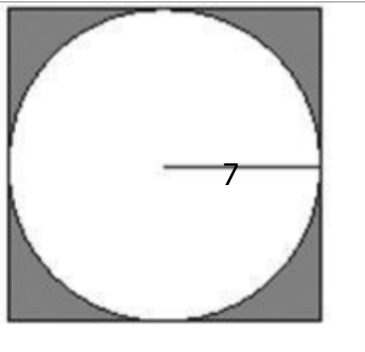

image not to scale

12) Assistent #91942 "91942 - 65824- area of shade square circle"

What is the area of the shaded region in the figure below? (Use 3.14 for π)

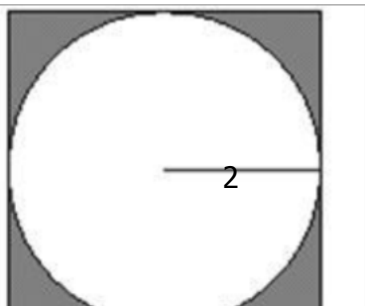



image not to scale

13) Assistent #91943 "91943 - 65824- area of shade square circle"

What is the area of the shaded region in the figure below? (Use 3.14 for π)

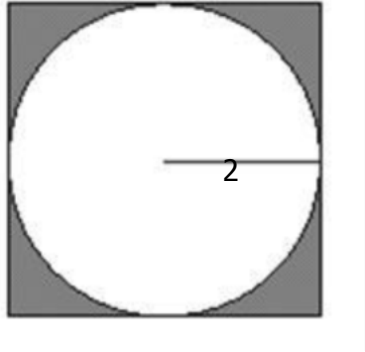

image not to scale

14) Assistent #91944 "91944 - 65824- area of shade square circle"

What is the area of the shaded region in the figure below? (Use 3.14 for π)

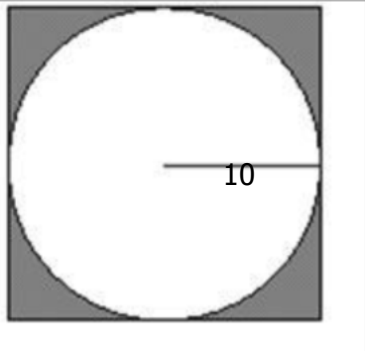

image not to scale

15) Assistent #91945 "91945 - 65824- area of shade square circle"

What is the area of the shaded region in the figure below? (Use 3.14 for π)

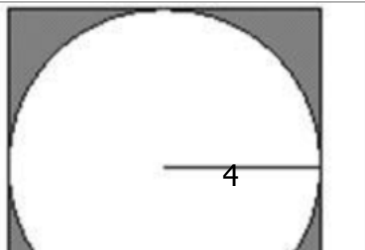



image not to scale

16) Assistent #91946 "91946 - 65824- area of shade square circle"

What is the area of the shaded region in the figure below? (Use 3.14 for π)

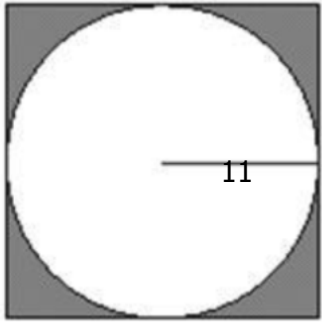

image not to scale

17) Assistent #91947 "91947 - 62276 - 58787 - Area of the irregular figure"

What is the area of this object with given information? use 3.14 for π .

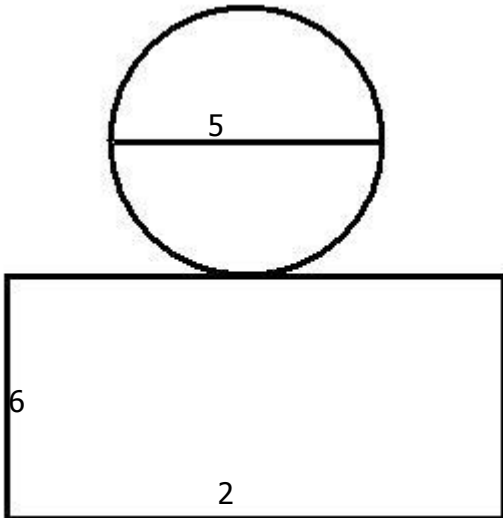

image not to scale

18) Assistent #91948 "91948 - 62276 - 58787 - Area of the irregular figure"

What is the area of this object with given information? use 3.14 for π .

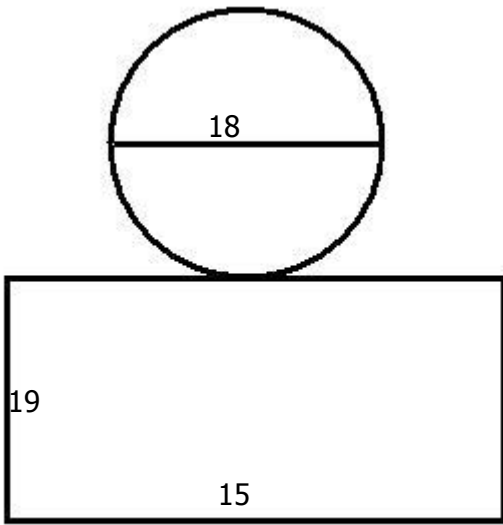

image not to scale

19) Assistent #91949 "91949 - 62276 - 58787 - Area of the irregular figure"

What is the area of this object with given information? use 3.14 for π .

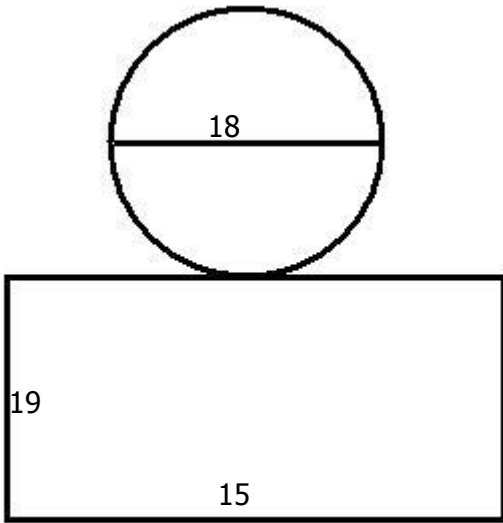

image not to scale

20) Assistent #91950 "91950 - 62276 - 58787 - Area of the irregular figure"

What is the area of this object with given information? use 3.14 for π .

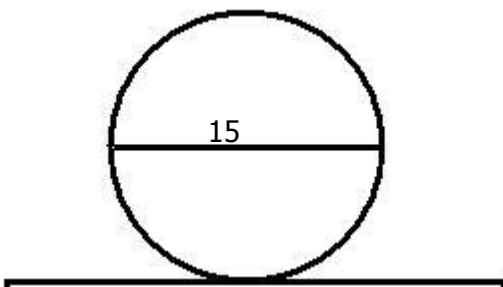



image not to scale

21) Assistent #91951 "91951 - 62276 - 58787 - Area of the irregular figure"

What is the area of this object with given information? use 3.14 for π .

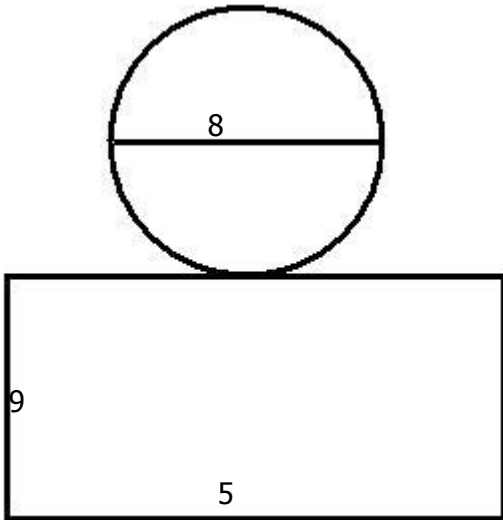

image not to scale

22) Assistent #91952 "91952 - 62276 - 58787 - Area of the irregular figure"

What is the area of this object with given information? use 3.14 for π .

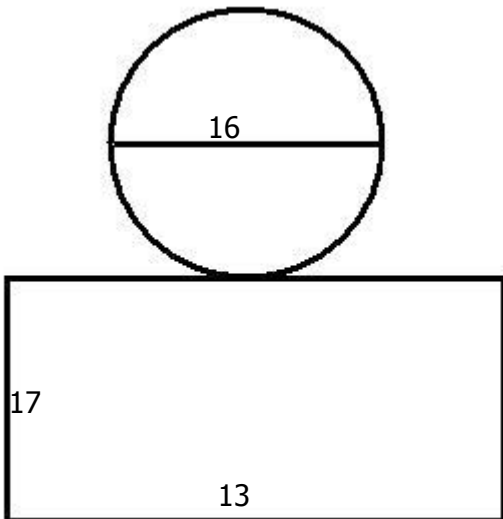

image not to scale

23) Assistent #91953 "91953 - 62276 - 58787 - Area of the irregular figure"

What is the area of this object with given information? use 3.14 for π .

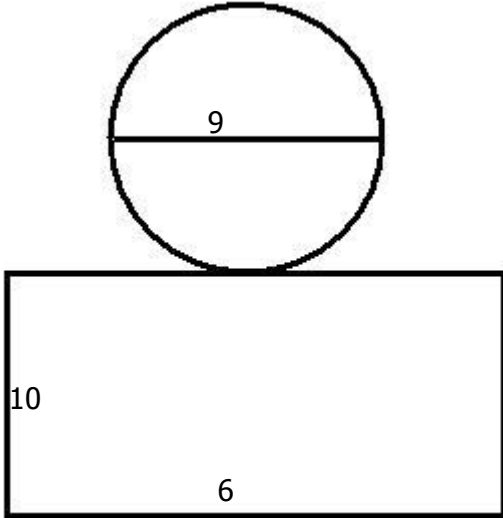

image not to scale

24) Assistent #91954 "91954 - 62276 - 58787 - Area of the irregular figure"

What is the area of this object with given information? use 3.14 for π .

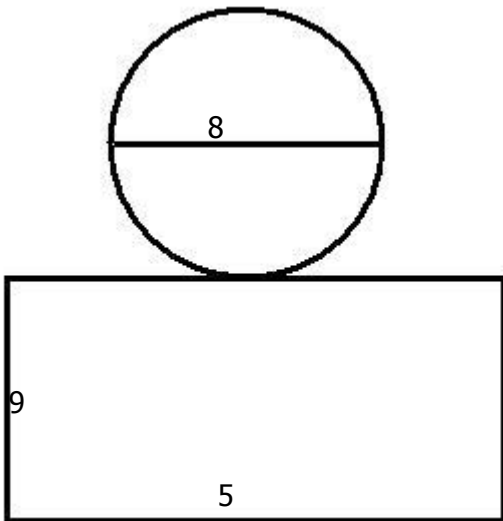

image not to scale

25) Assistent #91955 "91955 - 70532 - 62276 - 58787 - Area of the irregular figure"

What is the area of this object with given information? use 3.14 for π .

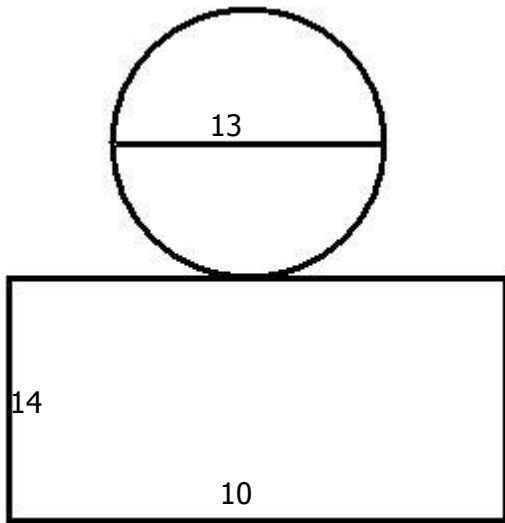

image not to scale

26) Assisment #91956 "91956 - 70532 - 62276 - 58787 - Area of the irregular figure"

What is the area of this object with given information? use 3.14 for π .

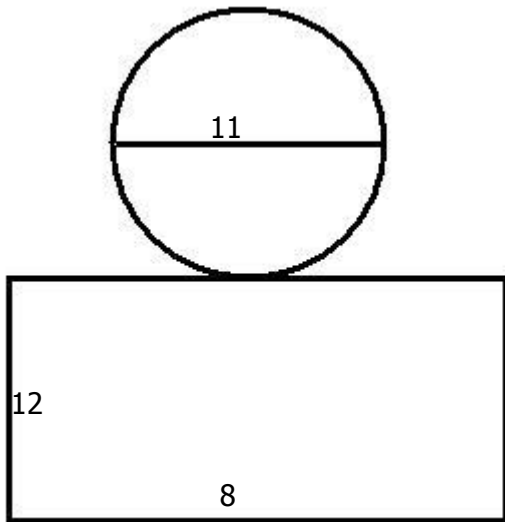
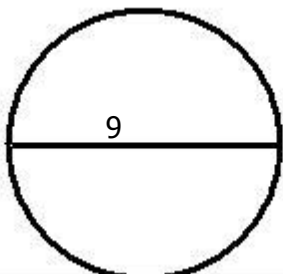

image not to scale

27) Assisment #91957 "91957 - 70532 - 62276 - 58787 - Area of the irregular figure"

What is the area of this object with given information? use 3.14 for π .



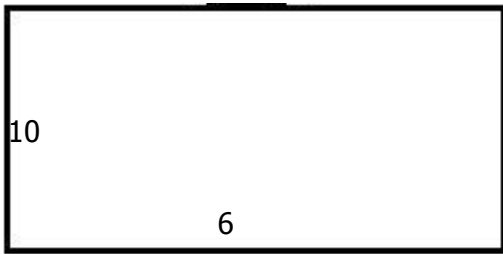

image not to scale

28) Assistent #91958 "91958 - 70532 - 62276 - 58787 - Area of the irregular figure"

What is the area of this object with given information? use 3.14 for π .

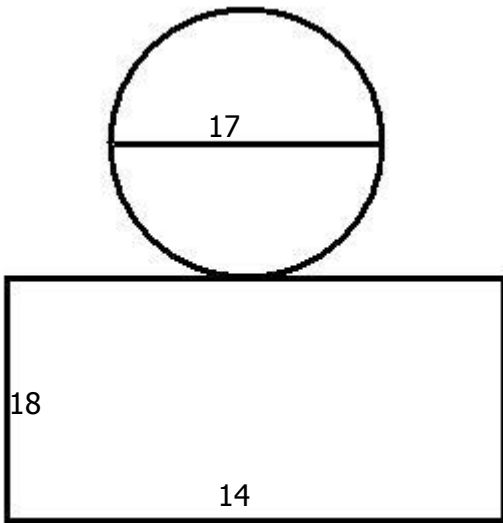

image not to scale

29) Assistent #91959 "91959 - 70532 - 62276 - 58787 - Area of the irregular figure"

What is the area of this object with given information? use 3.14 for π .

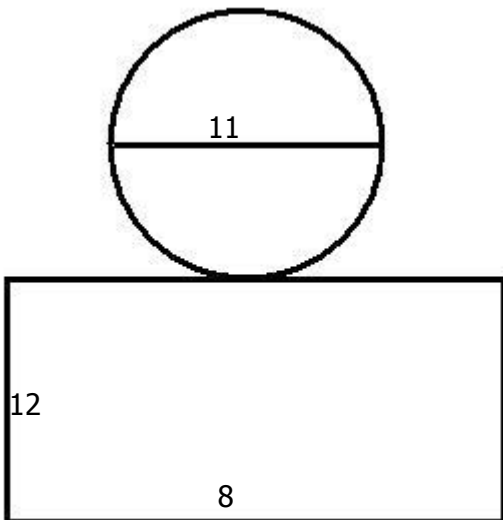

image not to scale

30) Assisment #91960 "91960 - 70532 - 62276 - 58787 - Area of the irregular figure"

What is the area of this object with given information? use 3.14 for π .

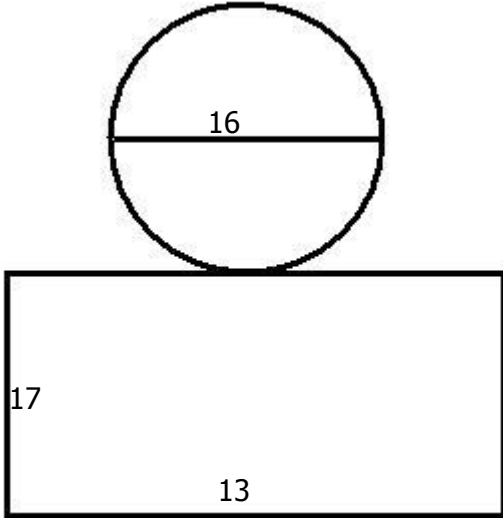

image not to scale

31) Assisment #91961 "91961 - 70532 - 62276 - 58787 - Area of the irregular figure"

What is the area of this object with given information? use 3.14 for π .

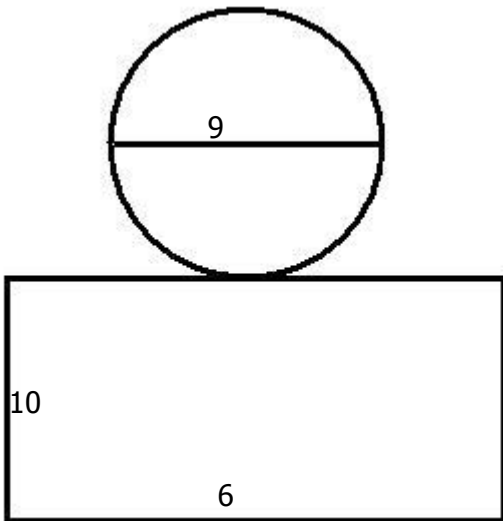

image not to scale

32) Assisment #91962 "91962 - 70532 - 62276 - 58787 - Area of the irregular figure"

What is the area of this object with given information? use 3.14 for π .

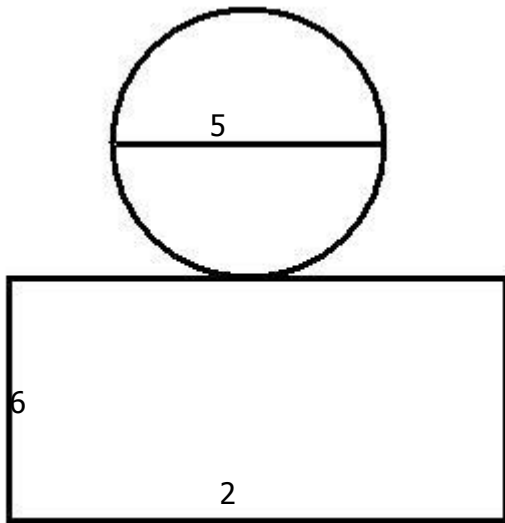

image not to scale

33) Assistent #91963 "91963 - 65824- area of shade square circle"

What is the area of the shaded region in the figure below? (Use 3.14 for π)

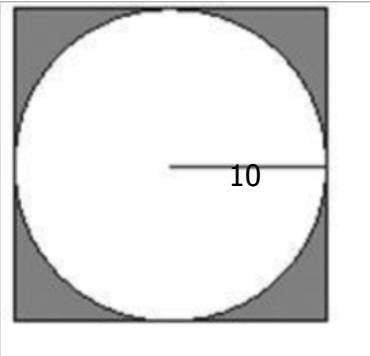

image not to scale

34) Assistent #91964 "91964 - 65824- area of shade square circle"

What is the area of the shaded region in the figure below? (Use 3.14 for π)

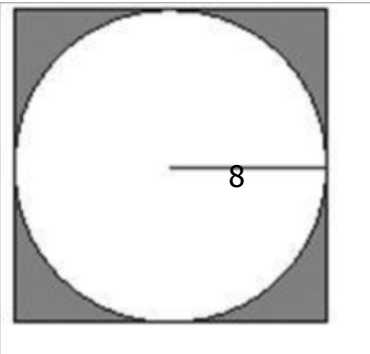

image not to scale

35) Assistent #91965 "91965 - 65824- area of shade square circle"

What is the area of the shaded region in the figure below? (Use 3.14 for π)

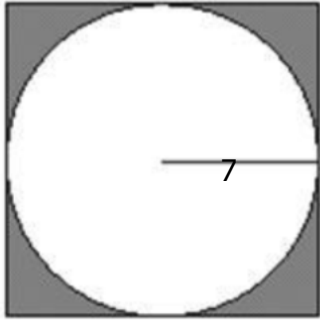

image not to scale

36) Assistent #91966 "91966 - 65824- area of shade square circle"

What is the area of the shaded region in the figure below? (Use 3.14 for π)

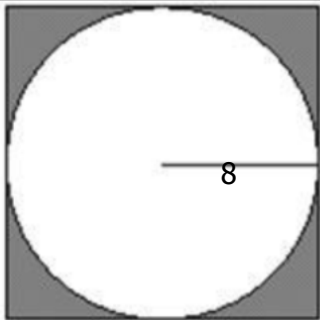

image not to scale

37) Assistent #91967 "91967 - 65824- area of shade square circle"

What is the area of the shaded region in the figure below? (Use 3.14 for π)

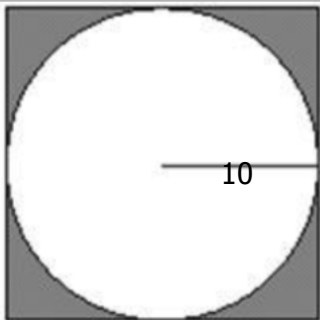

image not to scale

38) Assistent #91968 "91968 - 65824- area of shade square circle"

What is the area of the shaded region in the figure below? (Use 3.14 for π)

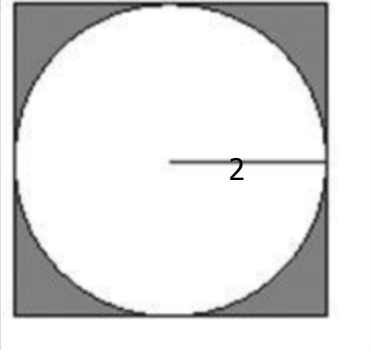

image not to scale

39) Assistent #91969 "91969 - 65824- area of shade square circle"

What is the area of the shaded region in the figure below? (Use 3.14 for π)

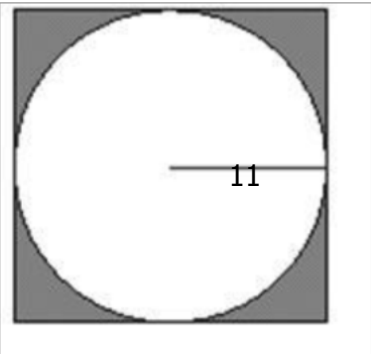

image not to scale

40) Assistent #91970 "91970 - 65824- area of shade square circle"

What is the area of the shaded region in the figure below? (Use 3.14 for π)

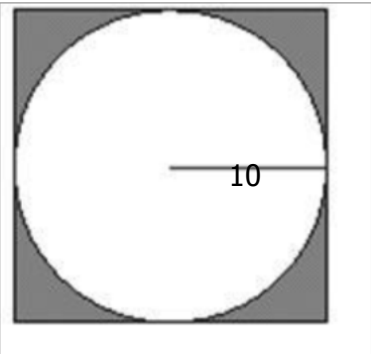

image not to scale

41) Assistent #91971 "91971 - 62276 - 58787 - Area of the irregular figure"

What is the area of this object with given information?

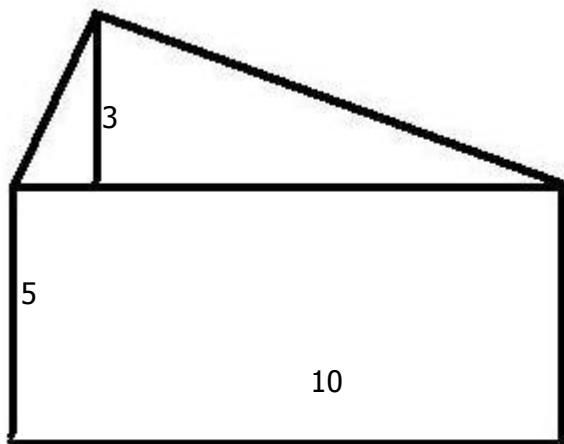

image not to scale

42) Assistent #91972 "91972 - 62276 - 58787 - Area of the irregular figure"

What is the area of this object with given information?

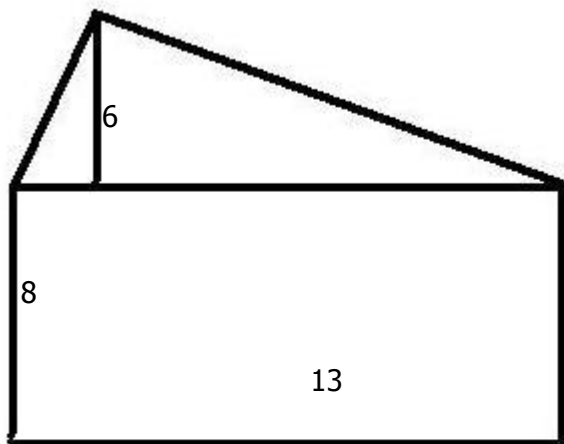

image not to scale

43) Assistent #91973 "91973 - 62276 - 58787 - Area of the irregular figure"

What is the area of this object with given information?

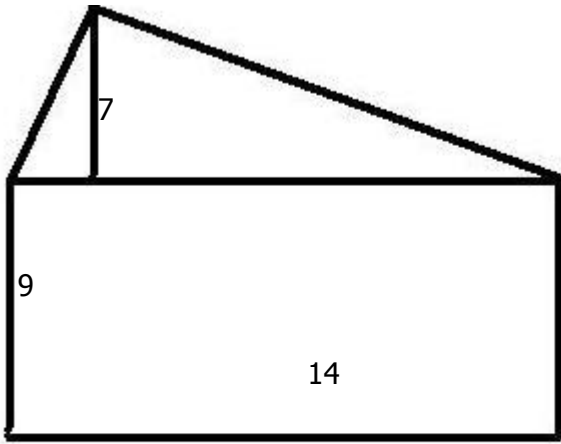

image not to scale

44) Assistent #91974 "91974 - 62276 - 58787 - Area of the irregular figure"

What is the area of this object with given information?

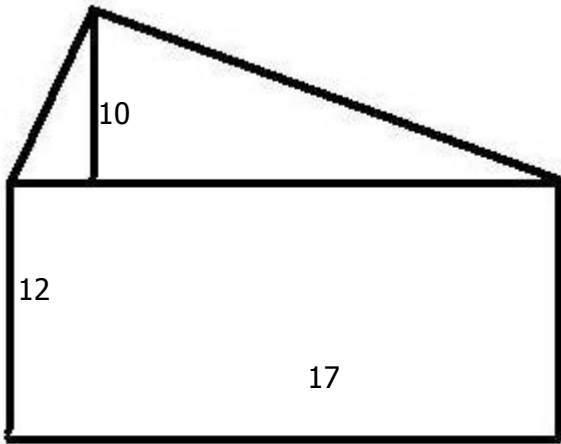

image not to scale

45) Assistent #91975 "91975 - 62276 - 58787 - Area of the irregular figure"

What is the area of this object with given information?



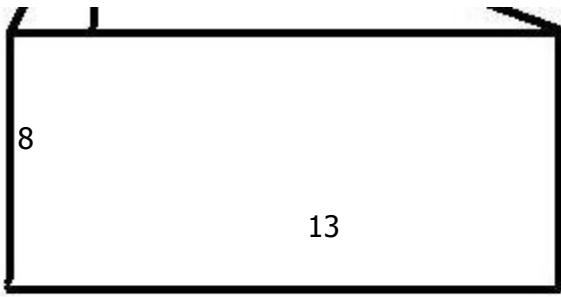

image not to scale

46) Assistent #91976 "91976 - 62276 - 58787 - Area of the irregular figure"

What is the area of this object with given information?

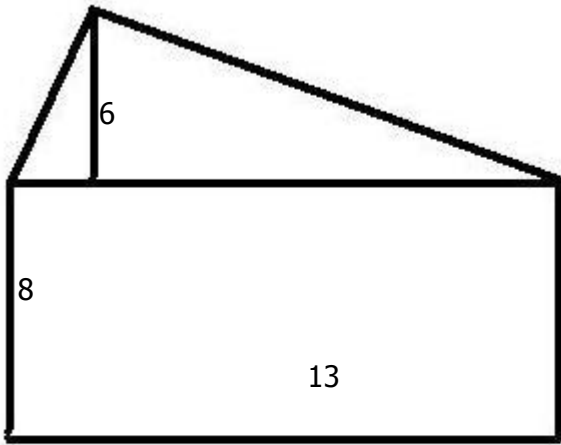
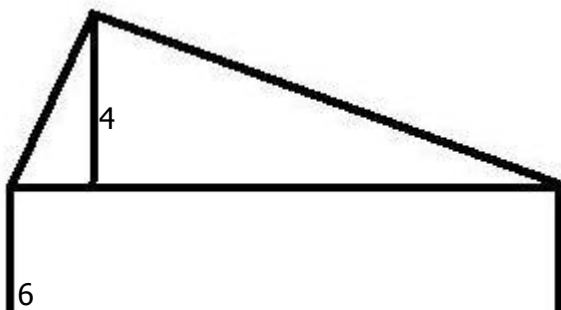

image not to scale

47) Assistent #91977 "91977 - 62276 - 58787 - Area of the irregular figure"

What is the area of this object with given information?



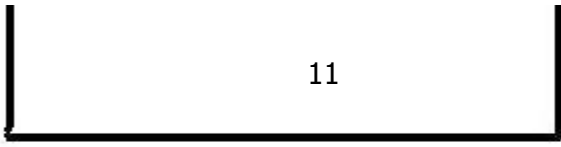

image not to scale

48) Assistent #91978 "91978 - 62276 - 58787 - Area of the irregular figure"

What is the area of this object with given information?

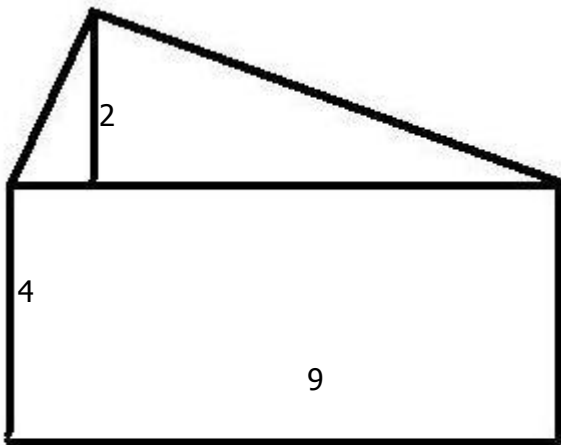

image not to scale

49) Assistent #91979 "91979 - 65929 square within square"

The figure below shows a square inscribed in a larger square. What is the area of the smaller square?

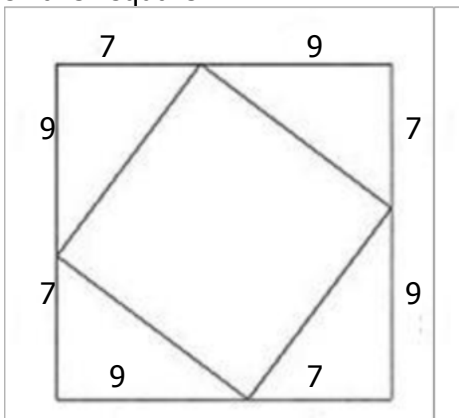

image not to scale

50) Assistent #91980 "91980 - 65929 square within square"

The figure below shows a square inscribed in a larger square. What is the area of the smaller square?

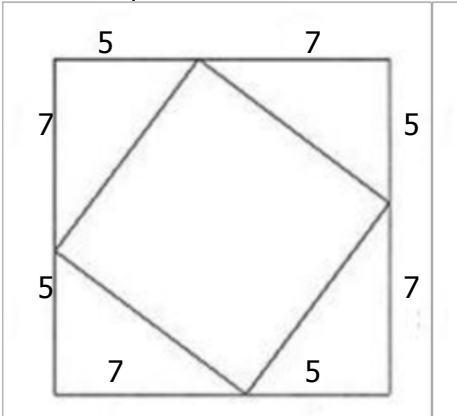

image not to scale

51) Assistent #91981 "91981 - 65929 square within square"

The figure below shows a square inscribed in a larger square. What is the area of the smaller square?

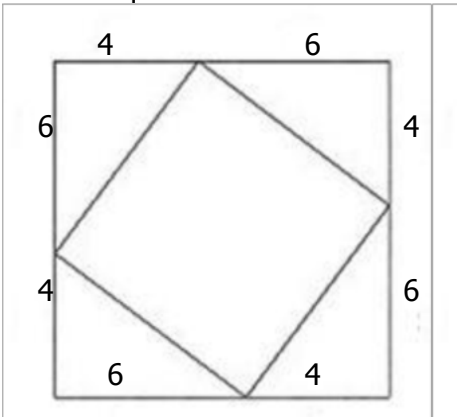
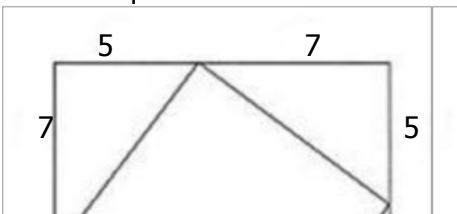

image not to scale

52) Assistent #91982 "91982 - 65929 square within square"

The figure below shows a square inscribed in a larger square. What is the area of the smaller square?



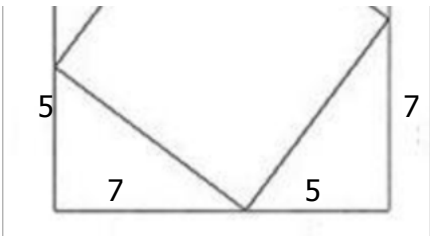

image not to scale

53) Assistent #91983 "91983 - 65929 square within square"

The figure below shows a square inscribed in a larger square. What is the area of the smaller square?

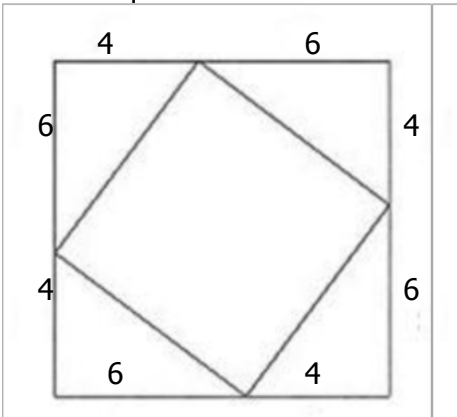

image not to scale

54) Assistent #91984 "91984 - 65929 square within square"

The figure below shows a square inscribed in a larger square. What is the area of the smaller square?

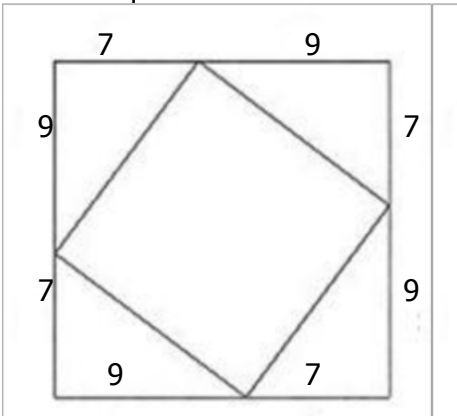

image not to scale

55) Assistent #91985 "91985 - 65929 square within square"

The figure below shows a square inscribed in a larger square. What is the area of the smaller square?

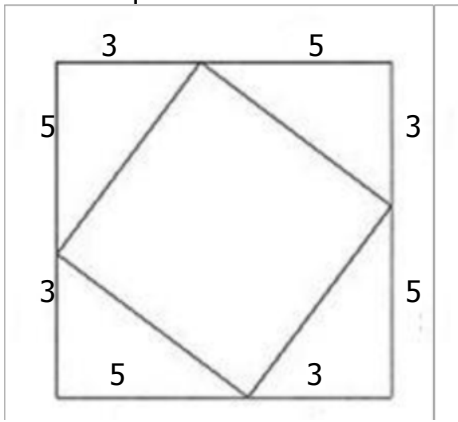

image not to scale

56) Assistent #91986 "91986 - 65929 square within square"

The figure below shows a square inscribed in a larger square. What is the area of the smaller square?

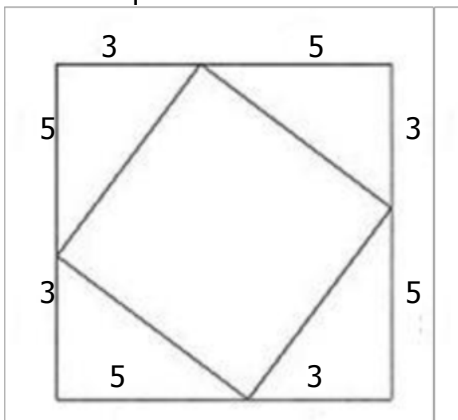

image not to scale

57) Assistent #91987 "91987 - 57350 - Superimposed circle areas with radius"

The outer circle has a radius of 12 and inner circle has a radius of 7. What is the area of the shaded region? Use 3.14 for π .

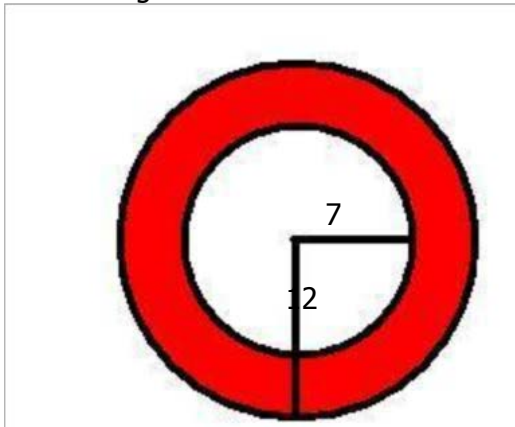

image not to scale

58) Assistent #91988 "91988 - 57350 - Superimposed circle areas with radius"

The outer circle has a radius of 8 and inner circle has a radius of 3. What is the area of the shaded region? Use 3.14 for π .

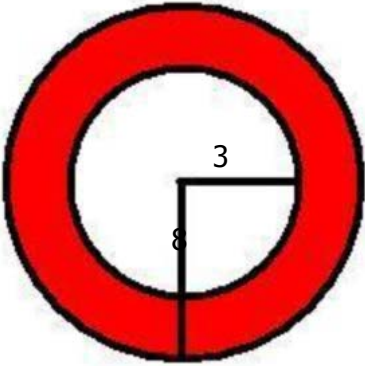

image not to scale

59) Assistent #91989 "91989 - 57350 - Superimposed circle areas with radius"

The outer circle has a radius of 12 and inner circle has a radius of 7. What is the area of the shaded region? Use 3.14 for π .

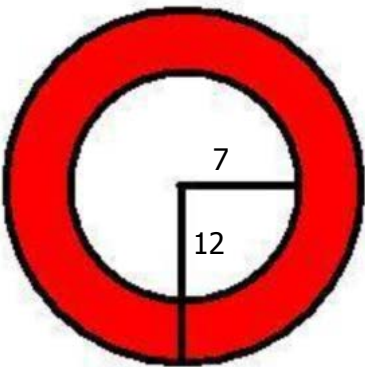

image not to scale

60) Assistent #91990 "91990 - 57350 - Superimposed circle areas with radius"

The outer circle has a radius of 8 and inner circle has a radius of 3. What is the area of the shaded region? Use 3.14 for π .

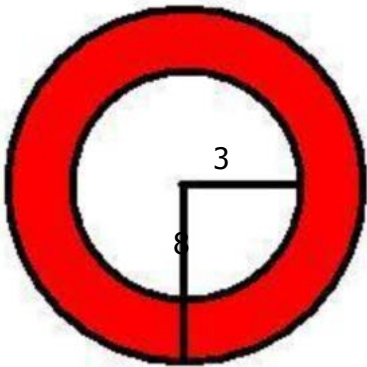

image not to scale

61) Assistent #91991 "91991 - 57350 - Superimposed circle areas with radius"

The outer circle has a radius of 12 and inner circle has a radius of 7. What is the area of the shaded region? Use 3.14 for π .

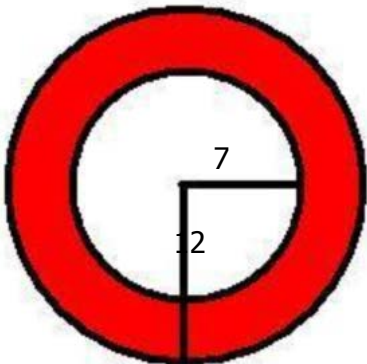

image not to scale

62) Assistent #91992 "91992 - 57350 - Superimposed circle areas with radius"

The outer circle has a radius of 11 and inner circle has a radius of 6. What is the area of the shaded region? Use 3.14 for π .

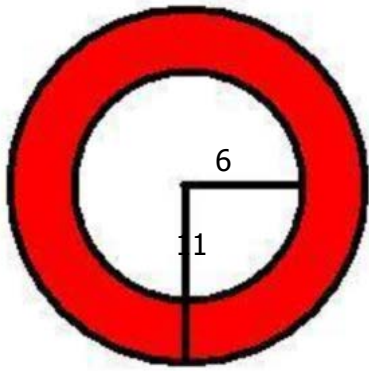

image not to scale

63) Assistent #91993 "91993 - 57350 - Superimposed circle areas with radius"

The outer circle has a radius of 10 and inner circle has a radius of 5. What is the area of the shaded region? Use 3.14 for π .

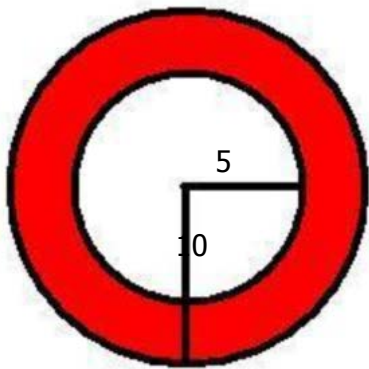
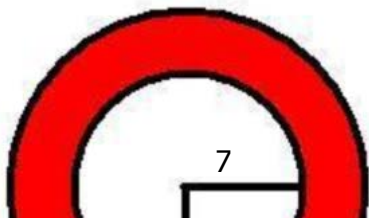

image not to scale

64) Assistent #91994 "91994 - 57350 - Superimposed circle areas with radius"

The outer circle has a radius of 12 and inner circle has a radius of 7. What is the area of the shaded region? Use 3.14 for π .



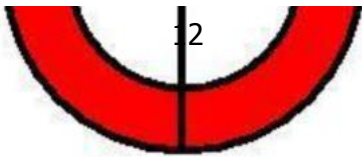

image not to scale

65) Assistent #91995 "91995 - 65929 square within square"

The figure below shows a square inscribed in a larger square. What is the area of the smaller square?

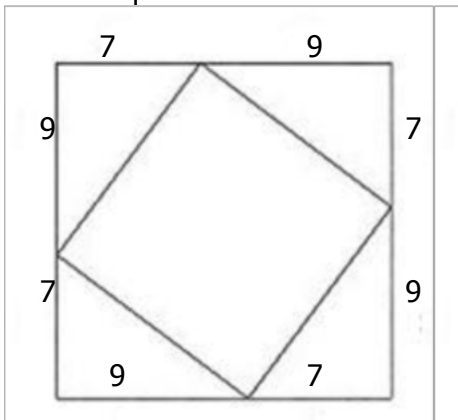

image not to scale

66) Assistent #91996 "91996 - 65929 square within square"

The figure below shows a square inscribed in a larger square. What is the area of the smaller square?

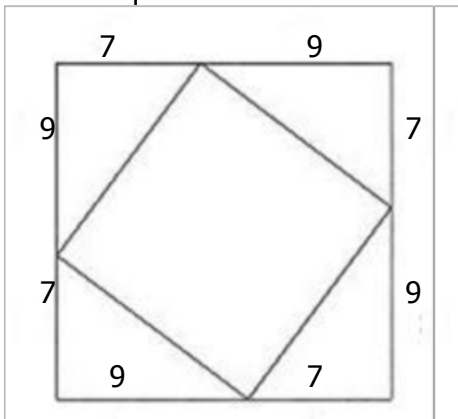

image not to scale

67) Assistent #91997 "91997 - 65929 square within square"

The figure below shows a square inscribed in a larger square. What is the area of the smaller square?

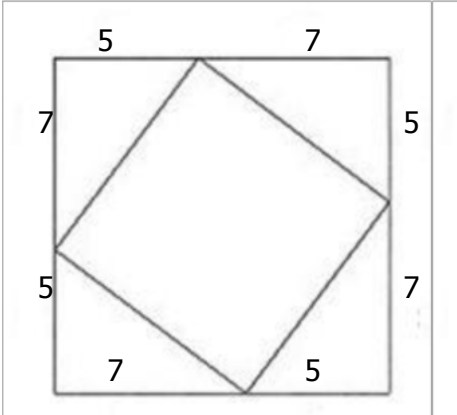

image not to scale

68) Assistent #91998 "91998 - 65929 square within square"

The figure below shows a square inscribed in a larger square. What is the area of the smaller square?

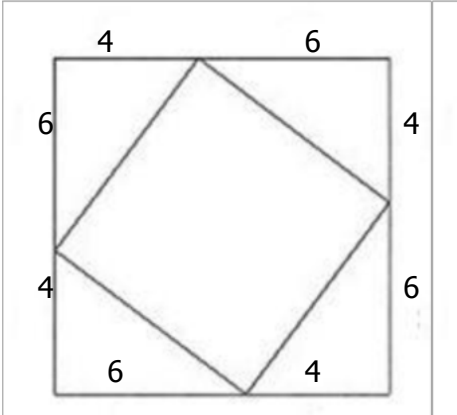

image not to scale

69) Assistent #91999 "91999 - 65929 square within square"

The figure below shows a square inscribed in a larger square. What is the area of the smaller square?

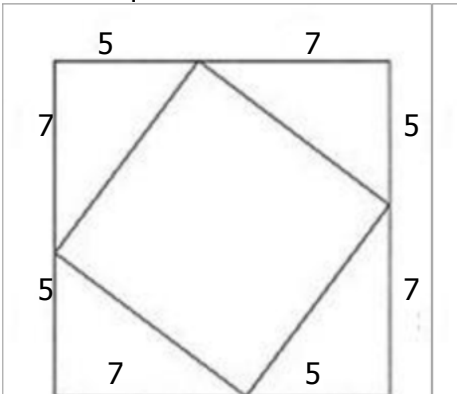

image not to scale

70) Assistent #92000 "92000 - 65929 square within square"

The figure below shows a square inscribed in a larger square. What is the area of the smaller square?

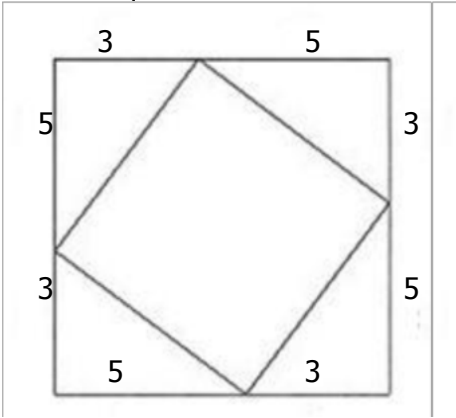

image not to scale

71) Assistent #92001 "92001 - 65929 square within square"

The figure below shows a square inscribed in a larger square. What is the area of the smaller square?

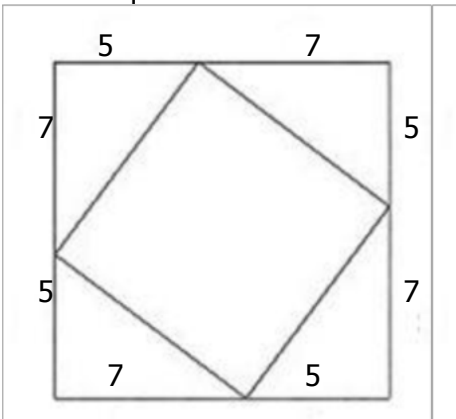
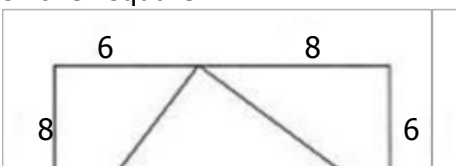

image not to scale

72) Assistent #92002 "92002 - 65929 square within square"

The figure below shows a square inscribed in a larger square. What is the area of the smaller square?



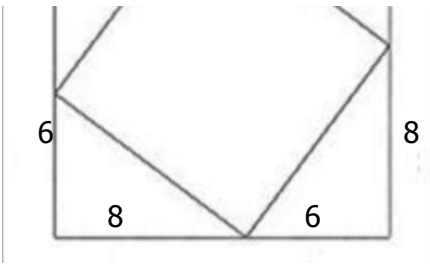

image not to scale

73) Assistent #92003 "92003 - 62276 - 58787 - Area of the irregular figure"

What is the area of this object with given information? Use 3.14 for π

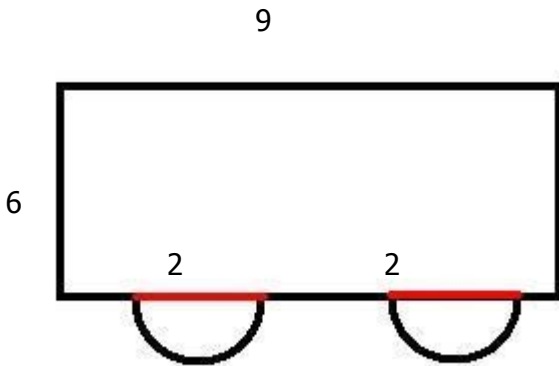

image not to scale

74) Assistent #92004 "92004 - 62276 - 58787 - Area of the irregular figure"

What is the area of this object with given information? Use 3.14 for π

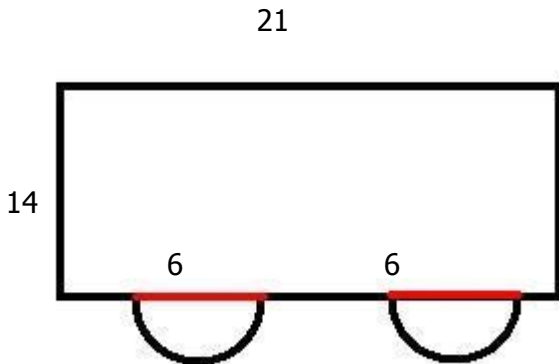

image not to scale

75) Assistent #92005 "92005 - 62276 - 58787 - Area of the irregular figure"

What is the area of this object with given information? Use 3.14 for π

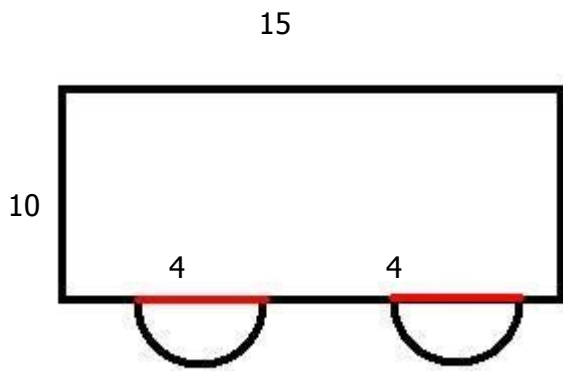

image not to scale

76) Assistent #92006 "92006 - 62276 - 58787 - Area of the irregular figure"

What is the area of this object with given information? Use 3.14 for π

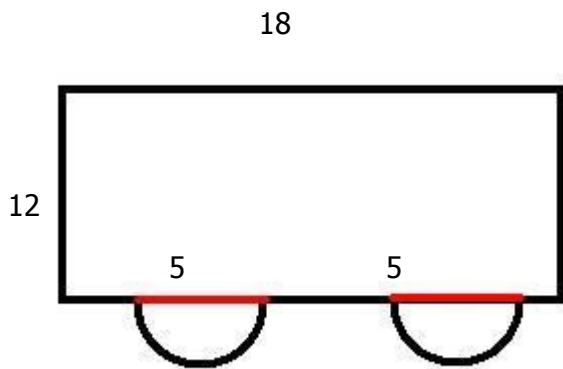

image not to scale

77) Assistent #92007 "92007 - 62276 - 58787 - Area of the irregular figure"

What is the area of this object with given information? Use 3.14 for π

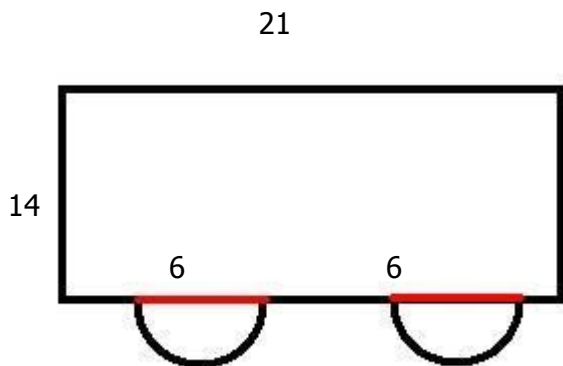

image not to scale

78) Assistent #92008 "92008 - 62276 - 58787 - Area of the irregular figure"

What is the area of this object with given information? Use 3.14 for π

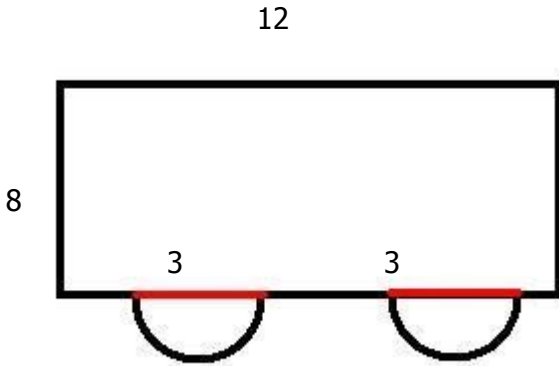

image not to scale

79) Assistent #92009 "92009 - 62276 - 58787 - Area of the irregular figure"

What is the area of this object with given information? Use 3.14 for π

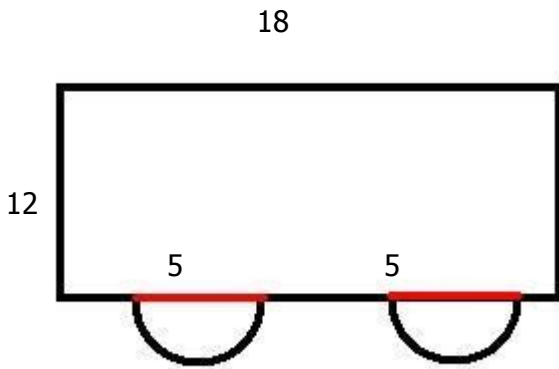
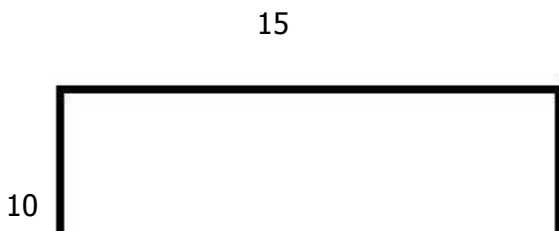

image not to scale

80) Assistent #92010 "92010 - 62276 - 58787 - Area of the irregular figure"

What is the area of this object with given information? Use 3.14 for π



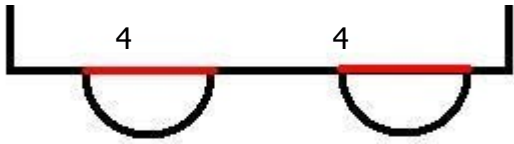

image not to scale

81) Assistent #92011 "92011 - 62276 - 58787 - Area of the irregular figure"

What is the area of this object with given information?

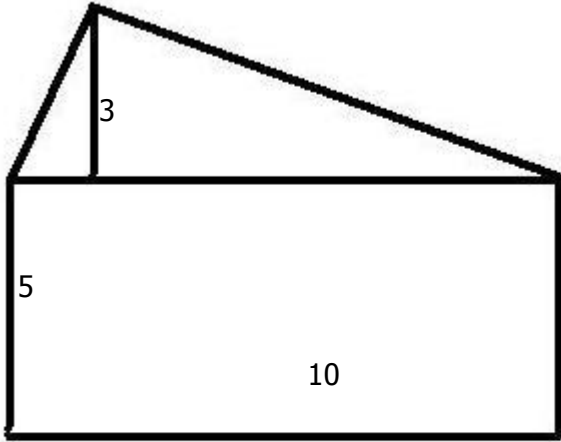

image not to scale

82) Assistent #92012 "92012 - 62276 - 58787 - Area of the irregular figure"

What is the area of this object with given information?

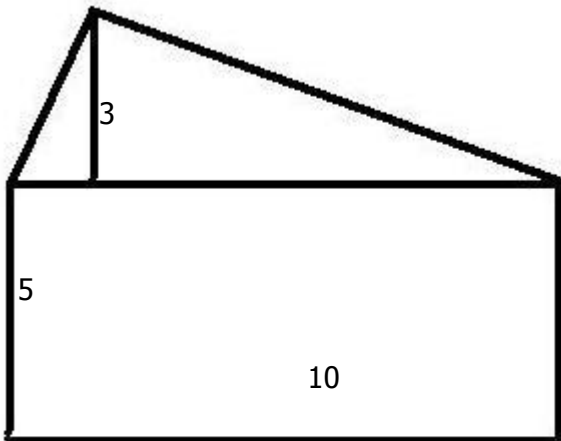

image not to scale

83) Assistent #92013 "92013 - 62276 - 58787 - Area of the irregular figure"

What is the area of this object with given information?

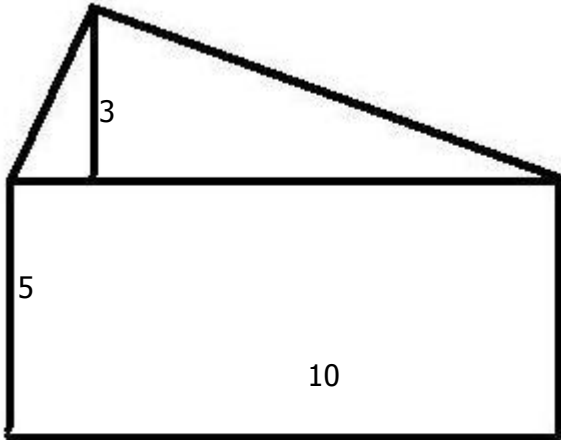

image not to scale

84) Assistent #92014 "92014 - 62276 - 58787 - Area of the irregular figure"

What is the area of this object with given information?

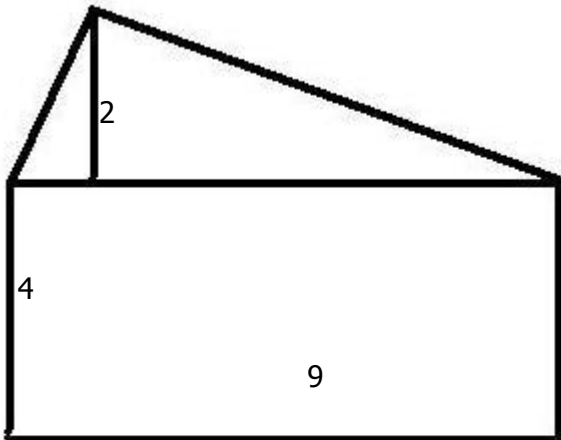

image not to scale

85) Assistent #92015 "92015 - 62276 - 58787 - Area of the irregular figure"

What is the area of this object with given information?

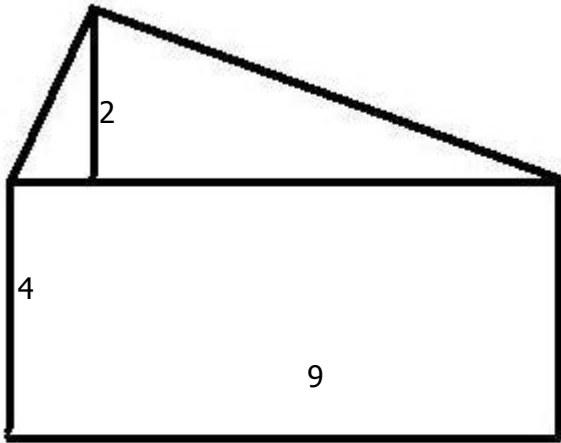

image not to scale

86) Assistent #92016 "92016 - 62276 - 58787 - Area of the irregular figure"

What is the area of this object with given information?

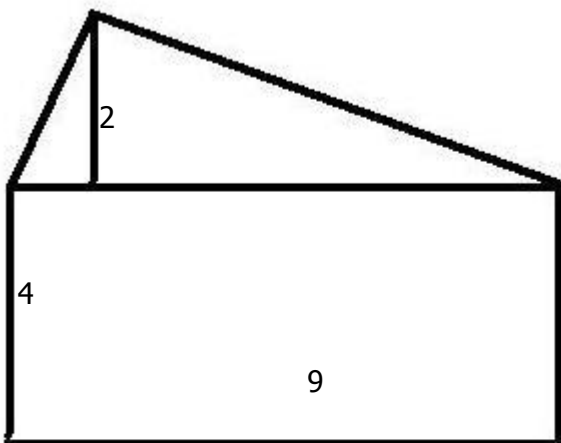

image not to scale

87) Assistent #92017 "92017 - 62276 - 58787 - Area of the irregular figure"

What is the area of this object with given information?

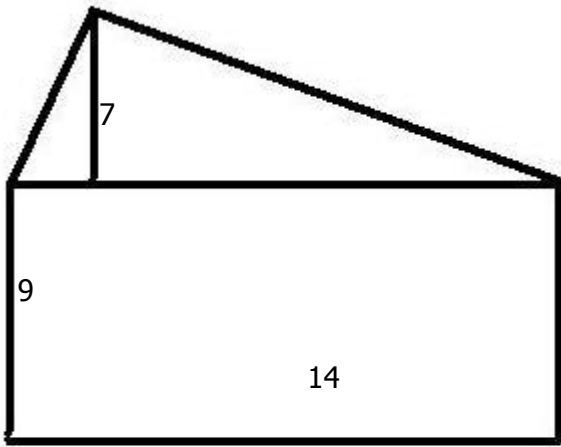

image not to scale

88) Assistent #92018 "92018 - 62276 - 58787 - Area of the irregular figure"

What is the area of this object with given information?

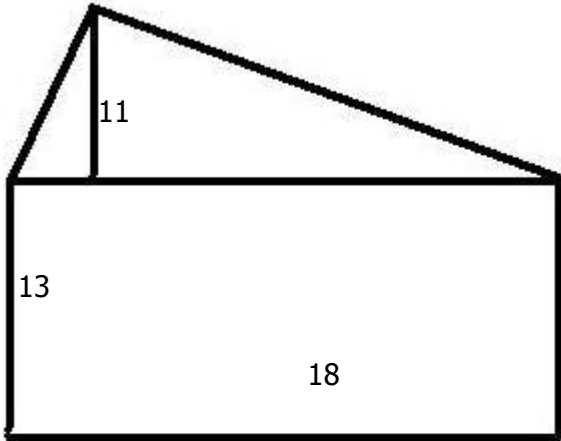

image not to scale

89) Assistent #92019 "92019 - 62276 - 58787 - Area of the irregular figure"

What is the area of this object with given information? Use 3.14 for π

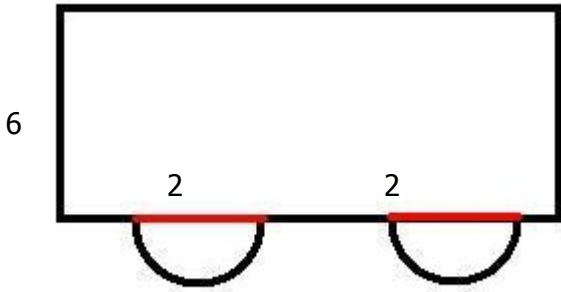

image not to scale

90) Assistent #92020 "92020 - 62276 - 58787 - Area of the irregular figure"

What is the area of this object with given information? Use 3.14 for π

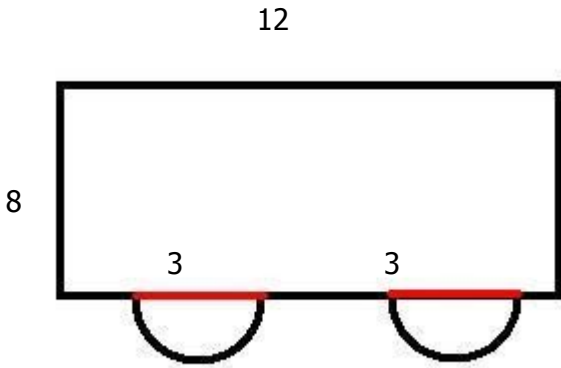

image not to scale

91) Assistent #92021 "92021 - 62276 - 58787 - Area of the irregular figure"

What is the area of this object with given information? Use 3.14 for π

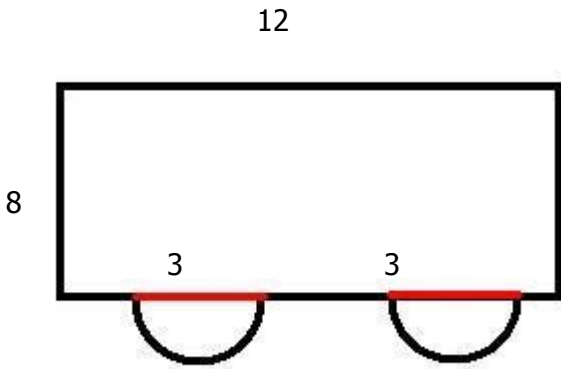

image not to scale

92) Assistent #92022 "92022 - 62276 - 58787 - Area of the irregular figure"

What is the area of this object with given information? Use 3.14 for π

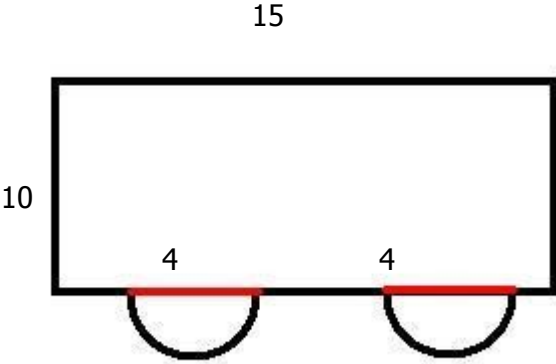

image not to scale

93) Assistent #92023 "92023 - 62276 - 58787 - Area of the irregular figure"

What is the area of this object with given information? Use 3.14 for π

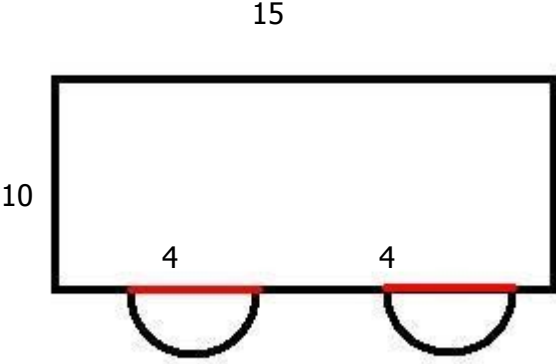

image not to scale

94) Assistent #92024 "92024 - 62276 - 58787 - Area of the irregular figure"

What is the area of this object with given information? Use 3.14 for π

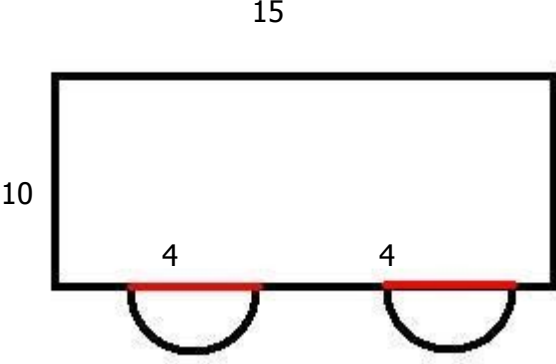

image not to scale

95) Assistent #92025 "92025 - 62276 - 58787 - Area of the irregular figure"

What is the area of this object with given information? Use 3.14 for π

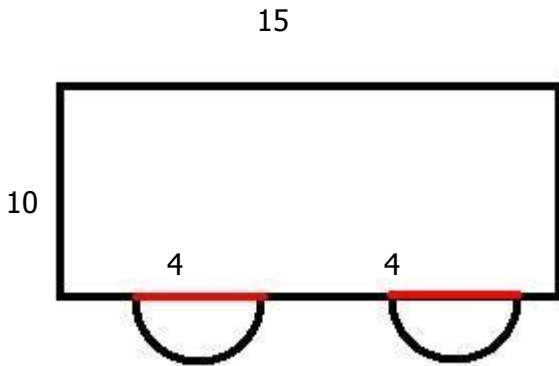

image not to scale

96) Assistent #92026 "92026 - 62276 - 58787 - Area of the irregular figure"

What is the area of this object with given information? Use 3.14 for π

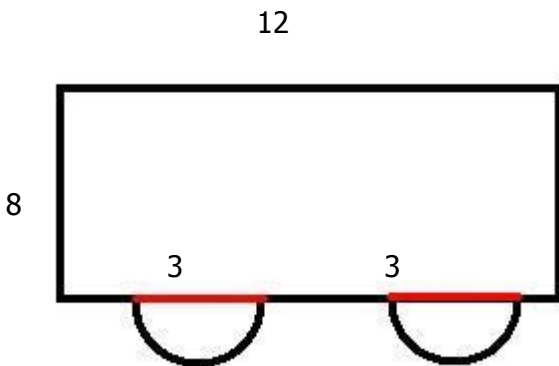

image not to scale

1) Assistent #87124 "87124 - 33259 - Solve for x (1.7)"

Solve for x.

$$7(8x + 6) = -1$$

Answer as a fraction.

2) Assistent #87125 "87125 - 33259 - Solve for x (1.7)"

Solve for x.

$$2(6x + 11) = -1$$

Answer as a fraction.

3) Assistent #87126 "87126 - 33259 - Solve for x (1.7)"

Solve for x.

$$11(2x + 11) = -7$$

Answer as a fraction.

4) Assistent #87127 "87127 - 33259 - Solve for x (1.7)"

Solve for x.

$$3(9x + 9) = 5$$

Answer as a fraction.

5) Assistent #87128 "87128 - 33259 - Solve for x (1.7)"

Solve for x.

$$9(2x + 8) = 5$$

Answer as a fraction.

6) Assistent #87129 "87129 - 33259 - Solve for x (1.7)"

Solve for x.

$$2(6x + 11) = 1$$

Answer as a fraction.

7) Assistent #87130 "87130 - 33259 - Solve for x (1.7)"

Solve for x.

$$9(8x + 3) = -3$$

Answer as a fraction.

8) Assistent #87131 "87131 - 33259 - Solve for x (1.7)"

Solve for x.

$$3(5x + 5) = 4$$

Answer as a fraction.

9) Assistent #87132 "87132 - 33259 - Solve for x (1.7)"

Solve for x.

$$5(9x + 3) = -4$$

Answer as a fraction.

10) Assistent #87133 "87133 - 33259 - Solve for x (1.7)"

Solve for x.

$$10(11x + 10) = -6$$

Answer as a fraction.

11) Assistent #87134 "87134 - 33259 - Solve for x (1.7)"

Solve for x.

$$7(10x + 5) = -4$$

Answer as a fraction.

12) Assistent #87135 "87135 - 33259 - Solve for x (1.7)"

Solve for x.

$$9(2x + 9) = -6$$

Answer as a fraction.

13) Assistent #87136 "87136 - 33259 - Solve for x (1.7)"

Solve for x.

$$2(7x + 3) = -3$$

Answer as a fraction.

14) Assisment #87137 "87137 - 33259 - Solve for x (1.7)"

Solve for x.

$$4(11x + 6) = -9$$

Answer as a fraction.

15) Assisment #87138 "87138 - 33260 - Solve for x (1.8)"

Solve for x.

$$8(7x - 3) = -6$$

Answer as a fraction.

16) Assisment #87139 "87139 - 33260 - Solve for x (1.8)"

Solve for x.

$$6(10x - 4) = -8$$

Answer as a fraction.

17) Assisment #87140 "87140 - 33260 - Solve for x (1.8)"

Solve for x.

$$4(11x - 3) = -1$$

Answer as a fraction.

18) Assisment #87141 "87141 - 33260 - Solve for x (1.8)"

Solve for x.

$$3(7x - 7) = -2$$

Answer as a fraction.

19) Assisment #87142 "87142 - 33260 - Solve for x (1.8)"

Solve for x.

$$9(9x - 3) = 0$$

Answer as a fraction.

20) Assisment #87143 "87143 - 33260 - Solve for x (1.8)"

21) Assistent #87144 "87144 - 33260 - Solve for x (1.8)"

Solve for x.

$$5(8x - 4) = -2$$

Answer as a fraction.

22) Assistent #87145 "87145 - 33260 - Solve for x (1.8)"

Solve for x.

$$8(11x - 9) = 0$$

Answer as a fraction.

23) Assistent #87146 "87146 - 33260 - Solve for x (1.8)"

Solve for x.

$$10(8x - 10) = 4$$

Answer as a fraction.

24) Assistent #87147 "87147 - 33260 - Solve for x (1.8)"

Solve for x.

$$11(7x - 8) = -8$$

Answer as a fraction.

25) Assistent #87148 "87148 - 33260 - Solve for x (1.8)"

Solve for x.

$$8(7x - 5) = -9$$

Answer as a fraction.

26) Assistent #87149 "87149 - 33260 - Solve for x (1.8)"

Solve for x.

$$4(3x - 2) = 3$$

Answer as a fraction.

28) Assistent #87151 "87151 - 33260 - Solve for x (1.8)"

Solve for x.

$$2(3x - 10) = -4$$

Answer as a fraction.

29) Assistent #87152 "87152 - 33261 - Solve for x (1.9)"

Solve for x.

$$8(4x + 4x) = -4$$

Answer as a fraction.

30) Assistent #87153 "87153 - 33261 - Solve for x (1.9)"

Solve for x.

$$4(6x + 6x) = 3$$

Answer as a fraction.

31) Assistent #87154 "87154 - 33261 - Solve for x (1.9)"

Solve for x.

$$4(4x + 3x) = -4$$

Answer as a fraction.

32) Assistent #87155 "87155 - 33261 - Solve for x (1.9)"

Solve for x.

$$4(11x + 10x) = -4$$

Answer as a fraction.

33) Assistent #87156 "87156 - 33261 - Solve for x (1.9)"

Solve for x.

$$6(7x + 6x) = 7$$

Answer as a fraction.

35) Assistent #87158 "87158 - 33261 - Solve for x (1.9)"

Solve for x.

$$2(7x + 10x) = -10$$

Answer as a fraction.

36) Assistent #87159 "87159 - 33261 - Solve for x (1.9)"

Solve for x.

$$7(9x + 11x) = -8$$

Answer as a fraction.

37) Assistent #87160 "87160 - 33261 - Solve for x (1.9)"

Solve for x.

$$5(6x + 6x) = -4$$

Answer as a fraction.

38) Assistent #87161 "87161 - 33261 - Solve for x (1.9)"

Solve for x.

$$11(4x + 10x) = 1$$

Answer as a fraction.

39) Assistent #87162 "87162 - 33261 - Solve for x (1.9)"

Solve for x.

$$6(8x + 6x) = -2$$

Answer as a fraction.

40) Assistent #87163 "87163 - 33261 - Solve for x (1.9)"

Solve for x.

$$3(9x + 4x) = -3$$

Answer as a fraction.

42) Assistent #87165 "87165 - 33261 - Solve for x (1.9)"

Solve for x.

$$3(4x + 11x) = -8$$

Answer as a fraction.

43) Assistent #87166 "87166 - 33264 - Solve for x (1.10)"

Solve for x.

$$8x(8 + 8) = -10$$

Answer as a fraction.

44) Assistent #87167 "87167 - 33264 - Solve for x (1.10)"

Solve for x.

$$10x(6 + 8) = 1$$

Answer as a fraction.

45) Assistent #87168 "87168 - 33264 - Solve for x (1.10)"

Solve for x.

$$2x(3 + 10) = 2$$

Answer as a fraction.

46) Assistent #87169 "87169 - 33264 - Solve for x (1.10)"

Solve for x.

$$5x(6 + 9) = -3$$

Answer as a fraction.

47) Assistent #87170 "87170 - 33264 - Solve for x (1.10)"

Solve for x.

$$9x(9 + 4) = -6$$

Answer as a fraction.

49) Assistent #87172 "87172 - 33264 - Solve for x (1.10)"

Solve for x.

$$5x(8 + 9) = 7$$

Answer as a fraction.

50) Assistent #87173 "87173 - 33264 - Solve for x (1.10)"

Solve for x.

$$7x(11 + 11) = -1$$

Answer as a fraction.

51) Assistent #87174 "87174 - 33264 - Solve for x (1.10)"

Solve for x.

$$5x(8 + 8) = -8$$

Answer as a fraction.

52) Assistent #87175 "87175 - 33264 - Solve for x (1.10)"

Solve for x.

$$7x(4 + 4) = 9$$

Answer as a fraction.

53) Assistent #87176 "87176 - 33264 - Solve for x (1.10)"

Solve for x.

$$4x(2 + 2) = -6$$

Answer as a fraction.

54) Assistent #87177 "87177 - 33264 - Solve for x (1.10)"

Solve for x.

$$3x(7 + 2) = 6$$

Answer as a fraction.

56) Assistent #87179 "87179 - 33264 - Solve for x (1.10)"

Solve for x.

$$11x(10 + 6) = -9$$

Answer as a fraction.

57) Assistent #87180 "87180 - Equation Solving"

Solve for x.

$$6x-8=10x+7$$

Answer as a fraction.

58) Assistent #87181 "87181 - Equation Solving"

Solve for x.

$$3x-8=6x+5$$

Answer as a fraction.

59) Assistent #87182 "87182 - Equation Solving"

Solve for x.

$$5x-10=8x+4$$

Answer as a fraction.

60) Assistent #87183 "87183 - Equation Solving"

Solve for x.

$$11x-4=12x+3$$

Answer as a fraction.

61) Assistent #87184 "87184 - Equation Solving"

Solve for x.

$$2x-10=3x+9$$

Answer as a fraction.

63) Assistent #87186 "87186 - Equation Solving"

Solve for x.

$$6x-8=8x+4$$

Answer as a fraction.

64) Assistent #87187 "87187 - Equation Solving"

Solve for x.

$$5x-5=8x+7$$

Answer as a fraction.

65) Assistent #87188 "87188 - Equation Solving"

Solve for x.

$$10x-9=14x+8$$

Answer as a fraction.

66) Assistent #87189 "87189 - Equation Solving"

Solve for x.

$$7x-2=10x+10$$

Answer as a fraction.

67) Assistent #87190 "87190 - Equation Solving"

Solve for x.

$$5x-10=6x+7$$

Answer as a fraction.

68) Assistent #87191 "87191 - Equation Solving"

Solve for x.

$$3x-7=4x+3$$

Answer as a fraction.

70) Assistent #87193 "87193 - Equation Solving"

Solve for x.

$$10x-8=12x+4$$

Answer as a fraction.

71) Assistent #87194 "87194 - Equation Solving"

Solve for x.

$$11x-4=14x+3$$

Answer as a fraction.

72) Assistent #87195 "87195 - 33261 - Solve for x (1.9)"

Solve for x.

$$5(8x - 12x) = 1$$

Answer as a fraction.

73) Assistent #87196 "87196 - 33261 - Solve for x (1.9)"

Solve for x.

$$6(8x - 9x) = -4$$

Answer as a fraction.

74) Assistent #87197 "87197 - 33261 - Solve for x (1.9)"

Solve for x.

$$6(7x - 10x) = -3$$

Answer as a fraction.

75) Assistent #87198 "87198 - 33261 - Solve for x (1.9)"

Solve for x.

$$2(8x - 6x) = -2$$

Answer as a fraction.

77) Assistent #87200 "87200 - 33261 - Solve for x (1.9)"

Solve for x.

$$3(14x - 9x) = 5$$

Answer as a fraction.

78) Assistent #87201 "87201 - 33261 - Solve for x (1.9)"

Solve for x.

$$11(9x - 7x) = -2$$

Answer as a fraction.

79) Assistent #87202 "87202 - 33261 - Solve for x (1.9)"

Solve for x.

$$5(15x - 17x) = 6$$

Answer as a fraction.

80) Assistent #87203 "87203 - 33261 - Solve for x (1.9)"

Solve for x.

$$9(13x - 18x) = 0$$

Answer as a fraction.

81) Assistent #87204 "87204 - 33261 - Solve for x (1.9)"

Solve for x.

$$7(13x - 14x) = -9$$

Answer as a fraction.

82) Assistent #87205 "87205 - 33261 - Solve for x (1.9)"

Solve for x.

$$6(14x - 12x) = -1$$

Answer as a fraction.

84) Assistent #87207 "87207 - 33261 - Solve for x (1.9)"

Solve for x.

$$2(15x - 20x) = -6$$

Answer as a fraction.

85) Assistent #87208 "87208 - 33261 - Solve for x (1.9)"

Solve for x.

$$10(7x - 8x) = 7$$

Answer as a fraction.

86) Assistent #87209 "87209 - 33261 - Solve for x (1.9)"

Solve for x.

$$2(9x - 11x) = -5$$

Answer as a fraction.

87) Assistent #87210 "87210 - Solve for x. 9(2 ..."

Solve for x.

$$9(2 + x) = 10(7 + x)$$

Answer as a fraction.

88) Assistent #87211 "87211 - Solve for x. 8(5 ..."

Solve for x.

$$8(5 + x) = 11(9 + x)$$

Answer as a fraction.

89) Assistent #87212 "87212 - Solve for x. 7(3 ..."

Solve for x.

$$7(3 + x) = 1(7 + x)$$

Answer as a fraction.

91) Assistent #87214 "87214 - Solve for x. 9(4 ..."

Solve for x.

$$9(4 + x) = 5(7 + x)$$

Answer as a fraction.

92) Assistent #87215 "87215 - Solve for x. 6(11..."

Solve for x.

$$6(11 + x) = 8(9 + x)$$

Answer as a fraction.

93) Assistent #87216 "87216 - Solve for x. 11(5..."

Solve for x.

$$11(5 + x) = 12(11 + x)$$

Answer as a fraction.

94) Assistent #87217 "87217 - Solve for x. 10(4..."

Solve for x.

$$10(4 + x) = 3(6 + x)$$

Answer as a fraction.

95) Assistent #87218 "87218 - Solve for x. 5(10..."

Solve for x.

$$5(10 + x) = -2(7 + x)$$

Answer as a fraction.

96) Assistent #87219 "87219 - Solve for x. 6(3 ..."

Solve for x.

$$6(3 + x) = 5(3 + x)$$

Answer as a fraction.

97) Assistent #87220 "87220 - Solve for x. 7(8 ..."

98) Assistent #87221 "87221 - Solve for x. 9(5 ..."

Solve for x.

$$9(5 + x) = 15(10 + x)$$

Answer as a fraction.

99) Assistent #87222 "87222 - Solve for x. 11(8..."

Solve for x.

$$11(8 + x) = 9(5 + x)$$

Answer as a fraction.

100) Assistent #87223 "87223 - Solve for x. 6(6 ..."

Solve for x.

$$6(6 + x) = 8(9 + x)$$

Answer as a fraction.

Problem Set) - * & "Addition - Decimals" id:[5962]

1) Assistent #34558 "34558 - Addition - Decimals: carry over of tenths"

What is $9.1 + -7.9$?

2) Assistent #34559 "34559 - Addition - Decimals: carry over of tenths"

What is $9.2 + -7.8$?

3) Assistent #34560 "34560 - Addition - Decimals: carry over of tenths"

What is $3.3 + -9.8$?

4) Assistent #34561 "34561 - Addition - Decimals: carry over of tenths"

What is $2.4 + -6.7$?

5) Assistent #34562 "34562 - Addition - Decimals: carry over of tenths"

What is $10.5 + -6.9$?

6) Assistent #34563 "34563 - Addition - Decimals: carry over of tenths"

What is $4.6 + -7.6$?

7) Assistent #34564 "34564 - Addition - Decimals: carry over of tenths"

What is $7.7 + -10.6$?

8) Assistent #34565 "34565 - Addition - Decimals: carry over of tenths"

What is $5.8 + -6.3$?

9) Assistent #34566 "34566 - Addition - Decimals: carry over of tenths"

What is $8.9 + -3.7$?

10) Assisment #34567 "34567 - Addition - Decimals: carry over of tenths"

What is $6.9 + -10.1$?

11) Assisment #34568 "34568 - Addition - Decimals: carry over of tenths"

What is $1.1 + -2.9$?

12) Assisment #34569 "34569 - Addition - Decimals: carry over of tenths"

What is $4.2 + -1.8$?

13) Assisment #34570 "34570 - Addition - Decimals: carry over of tenths"

What is $10.3 + -4.9$?

14) Assisment #34571 "34571 - Addition - Decimals: carry over of tenths"

What is $4.4 + -3.9$?

15) Assisment #34572 "34572 - Addition - Decimals: carry over of tenths"

What is $10.5 + -10.6$?

16) Assisment #34573 "34573 - Addition - Decimals: carry over of tenths"

What is $8.6 + -1.4$?

17) Assisment #34574 "34574 - Addition - Decimals: carry over of tenths"

What is $8.7 + -3.3$?

18) Assisment #34575 "34575 - Addition - Decimals: carry over of tenths"

What is $6.8 + -7.3$?

19) Assisment #34576 "34576 - Addition - Decimals: carry over of tenths"

What is $5.9 + -2.6$?

20) Assisment #34577 "34577 - Addition - Decimals: carry over of tenths"

What is $3.9 + -9.1$?

21) Assisment #34578 "34578 - Addition - Decimals: carry over of tenths"

What is $2.1 + -5.9$?

22) Assisment #34579 "34579 - Addition - Decimals: carry over of tenths"

What is $7.2 + -4.8$?

23) Assisment #34580 "34580 - Addition - Decimals: carry over of tenths"

What is $7.3 + -6.9$?

24) Assisment #34581 "34581 - Addition - Decimals: carry over of tenths"

What is $9.4 + -9.6$?

25) Assisment #34582 "34582 - Addition - Decimals: carry over of tenths"

What is $10.5 + -6.5$?

26) Assisment #34583 "34583 - Addition - Decimals: carry over of tenths"

What is $1.6 + -7.8$?

27) Assisment #34584 "34584 - Addition - Decimals: carry over of tenths"

What is $6.7 + -2.6$?

28) Assisment #34585 "34585 - Addition - Decimals: carry over of tenths"

What is $10.8 + -8.4$?

29) Assisment #34586 "34586 - Addition - Decimals: carry over of tenths"

What is $7.9 + -7.9$?

30) Assisment #34587 "34587 - Addition - Decimals: carry over of tenths"

What is $7.9 + -1.1$?

Problem Set , - (* "Substitution - THE SKILL BUILDING SET" id:[8946]

1) Assistent #69415 "69415 - If x = 2 and y = ..."

If x = 2 and y = 8. what is the value of the following expression?

$$5x-7y$$

2) Assistent #69416 "69416 - If x = 4 and y = ..."

If x = 4 and y = 4. what is the value of the following expression?

$$7x-3y$$

3) Assistent #69417 "69417 - If x = 8 and y = ..."

If x = 8 and y = 3. what is the value of the following expression?

$$5x-2y$$

4) Assistent #69418 "69418 - If x = 7 and y = ..."

If x = 7 and y = 8. what is the value of the following expression?

$$4x-9y$$

5) Assistent #69419 "69419 - If x = 4 and y = ..."

If x = 4 and y = 7. what is the value of the following expression?

$$8x-3y$$

6) Assistent #69420 "69420 - If x = 4 and y = ..."

If x = 4 and y = 7. what is the value of the following expression?

$$2x-6y$$

7) Assistent #69421 "69421 - If x = 8 and y = ..."

If x = 8 and y = 1. what is the value of the following expression?

$$4x-8y$$

8) Assistent #69422 "69422 - If x = 3 and y = ..."

If x = 3 and y = 6. what is the value of the following expression?

$$4x-2y$$

9) Assistent #69423 "69423 - If x = 5 and y = ..."

If x = 5 and y = 7. what is the value of the following expression?

$$8x-6y$$

10) Assistent #69424 "69424 - If x = 9 and y = ..."

If x = 9 and y = 3. what is the value of the following expression?

$$4x-4y$$

11) Assistent #69425 "69425 - If x = 5 and y = ..."

If x = 5 and y = 1. what is the value of the following expression?

$$7x-5y$$

12) Assistent #69426 "69426 - If x = 5 and y = ..."

If x = 5 and y = 5. what is the value of the following expression?

$$3x-2y$$

13) Assistent #69427 "69427 - If x = 6 and y = ..."

If x = 6 and y = 5. what is the value of the following expression?

$$7x-9y$$

14) Assistent #69428 "69428 - If x = 1 and y = ..."

If x = 1 and y = 4. what is the value of the following expression?

$$5x-2y$$

15) Assistent #69429 "69429 - If x = 7 and y = ..."

If x = 7 and y = 8. what is the value of the following expression?

$$4x-7y$$

16) Assistent #69430 "69430 - If x = 8 and y = ..."

If x = 8 and y = 8 what is the value of the following expression?

$$2(x - 2(x - y))$$

18) Assistent #69432 "69432 - If x = 8 and y = ..."

If x = 8 and y = 5 what is the value of the following expression?

$$3(x - 2(x - y))$$

19) Assistent #69433 "69433 - If x = 3 and y = ..."

If x = 3 and y = 3 what is the value of the following expression?

$$3(x - 3(x - y))$$

20) Assistent #69434 "69434 - If x = 7 and y = ..."

If x = 7 and y = 1 what is the value of the following expression?

$$4(x - 2(x - y))$$

21) Assistent #69435 "69435 - If x = 4 and y = ..."

If x = 4 and y = 9 what is the value of the following expression?

$$2(x - 3(x - y))$$

22) Assistent #69436 "69436 - If x = 4 and y = ..."

If x = 4 and y = 2 what is the value of the following expression?

$$3(x - 2(x - y))$$

23) Assistent #69437 "69437 - If x = 7 and y = ..."

If x = 7 and y = 8 what is the value of the following expression?

$$5(x - 2(x - y))$$

24) Assistent #69438 "69438 - If x = 3 and y = ..."

If x = 3 and y = 2 what is the value of the following expression?

$$4(x - 3(x - y))$$

25) Assistent #69439 "69439 - If x = 8 and y = ..."

If x = 8 and y = 5 what is the value of the following expression?

$$5(x - 3(x - y))$$

27) Assistent #69441 "69441 - If x = 8 and y = ..."

If $x = 8$ and $y = 3$ what is the value of the following expression?

$$3(x - 2(x - y))$$

28) Assistent #69442 "69442 - If x = 2 and y = ..."

If $x = 2$ and $y = 2$ what is the value of the following expression?

$$2(x - 3(x - y))$$

29) Assistent #69443 "69443 - If x = 2 and y = ..."

If $x = 2$ and $y = 1$ what is the value of the following expression?

$$4(x - 2(x - y))$$

30) Assistent #69444 "69444 - If x = 1 and y = ..."

If $x = 1$ and $y = 6$ what is the value of the following expression?

$$5(x - 2(x - y))$$

31) Assistent #69445 "69445 - 27601 - Substitution - Double - Add + Multiply - Medium"

If x is equal to 4 and y is equal to 15

then what is the value of $x + 10y$?

32) Assistent #69446 "69446 - 27601 - Substitution - Double - Add + Multiply - Medium"

If x is equal to 17 and y is equal to 8

then what is the value of $x + 2y$?

33) Assistent #69447 "69447 - 27601 - Substitution - Double - Add + Multiply - Medium"

If x is equal to 1 and y is equal to 13

then what is the value of $x + 11y$?

34) Assistent #69448 "69448 - 27601 - Substitution - Double - Add + Multiply - Medium"

If x is equal to 6 and y is equal to 1
then what is the value of $x + 15y$?

35) Assistent #69449 "69449 - 27601 - Substitution - Double - Add + Multiply - Medium"

If x is equal to 17 and y is equal to 11
then what is the value of $x + 14y$?

36) Assistent #69450 "69450 - 27601 - Substitution - Double - Add + Multiply - Medium"

If x is equal to 14 and y is equal to 9
then what is the value of $x + 6y$?

37) Assistent #69451 "69451 - 27601 - Substitution - Double - Add + Multiply - Medium"

If x is equal to 16 and y is equal to 14
then what is the value of $x + 12y$?

38) Assistent #69452 "69452 - 27601 - Substitution - Double - Add + Multiply - Medium"

If x is equal to 18 and y is equal to 4
then what is the value of $x + 3y$?

39) Assistent #69453 "69453 - 27601 - Substitution - Double - Add + Multiply - Medium"

If x is equal to 19 and y is equal to 17
then what is the value of $x + 6y$?

40) Assistent #69454 "69454 - 27601 - Substitution - Double - Add + Multiply - Medium"

If x is equal to 17 and y is equal to 8
then what is the value of $x + 7y$?

41) Assistent #69455 "69455 - 27601 - Substitution - Double - Add + Multiply - Medium"

If x is equal to 14 and y is equal to 13
then what is the value of $x + 17y$?

42) Assistent #69456 "69456 - 27601 - Substitution - Double - Add + Multiply - Medium"

If x is equal to 8 and y is equal to 2
then what is the value of $x + 20y$?

43) Assistent #69457 "69457 - 27601 - Substitution - Double - Add + Multiply - Medium"

If x is equal to 3 and y is equal to 15
then what is the value of $x + 17y$?

44) Assistent #69458 "69458 - 27601 - Substitution - Double - Add + Multiply - Medium"

If x is equal to 17 and y is equal to 11
then what is the value of $x + 3y$?

45) Assistent #69459 "69459 - 27601 - Substitution - Double - Add + Multiply - Medium"

If x is equal to 5 and y is equal to 4
then what is the value of $x + 15y$?

46) Assistent #69460 "69460 - Substitution - Double - Subtract + Multiply - Medium"

If x is equal to 44 and y is equal to 4
then what is the value of $x - 3y$?

47) Assistent #69461 "69461 - Substitution - Double - Subtract + Multiply - Medium"

If x is equal to 50 and y is equal to 7
then what is the value of $x - 5y$?

48) Assistent #69462 "69462 - Substitution - Double - Subtract + Multiply - Medium"

If x is equal to 51 and y is equal to 5
then what is the value of $x - 2y$?

49) Assistent #69463 "69463 - Substitution - Double - Subtract + Multiply - Medium"

If x is equal to 50 and y is equal to 7
then what is the value of $x - 2y$?

50) Assistent #69464 "69464 - Substitution - Double - Subtract + Multiply - Medium"

If x is equal to 50 and y is equal to 1
then what is the value of $x - 4y$?

51) Assistent #69465 "69465 - Substitution - Double - Subtract + Multiply - Medium"

If x is equal to 59 and y is equal to 2
then what is the value of $x - 4y$?

52) Assistent #69466 "69466 - Substitution - Double - Subtract + Multiply - Medium"

If x is equal to 51 and y is equal to 8
then what is the value of $x - 3y$?

53) Assistent #69467 "69467 - Substitution - Double - Subtract + Multiply - Medium"

If x is equal to 59 and y is equal to 4
then what is the value of $x - 4y$?

54) Assistent #69468 "69468 - Substitution - Double - Subtract + Multiply - Medium"

If x is equal to 45 and y is equal to 8
then what is the value of $x - 2y$?

55) Assistent #69469 "69469 - Substitution - Double - Subtract + Multiply - Medium"

If x is equal to 58 and y is equal to 1
then what is the value of $x - 5y$?

56) Assistent #69470 "69470 - If $x = 1$ and $y = \dots$ "

If $x = 1$ and $y = 2$ what is the value of the following expression?
 $y + (xy + 5x)$

57) Assistent #69471 "69471 - If $x = 4$ and $y = \dots$ "

If $x = 4$ and $y = 1$ what is the value of the following expression?
 $y + (xy + 2x)$

58) Assistent #69472 "69472 - If $x = 3$ and $y = \dots$ "

If $x = 3$ and $y = 7$ what is the value of the following expression?
 $y + (xy + 2x)$

59) Assistent #69473 "69473 - If $x = 8$ and $y = \dots$ "

If $x = 8$ and $y = 4$ what is the value of the following expression?
 $y + (xy + 3x)$

60) Assistent #69474 "69474 - If $x = 5$ and $y = \dots$ "

If $x = 5$ and $y = 5$ what is the value of the following expression?
 $y + (xy + 4x)$

61) Assistent #69475 "69475 - If $x = 8$ and $y = \dots$ "

If $x = 8$ and $y = 7$ what is the value of the following expression?
 $y + (xy + 5x)$

62) Assistent #69476 "69476 - If $x = 4$ and $y = \dots$ "

If $x = 4$ and $y = 2$ what is the value of the following expression?
 $y + (xy + 5x)$

63) Assistent #69477 "69477 - If $x = 1$ and $y = \dots$ "

If $x = 1$ and $y = 5$ what is the value of the following expression?
 $y + (xy + 3x)$

64) Assistent #69478 "69478 - If $x = 4$ and $y = \dots$ "

If $x = 4$ and $y = 4$ what is the value of the following expression?
 $y + (xy + 4x)$

65) Assistent #69479 "69479 - If $x = 5$ and $y = \dots$ "

If $x = 5$ and $y = 8$ what is the value of the following expression?
 $y + (xy + 5x)$

66) Assistent #69480 "69480 - If $x = 4$ and $y = \dots$ "

If $x = 4$ and $y = 8$ what is the value of the following expression?
 $y + (xy + 5x)$

67) Assistent #69481 "69481 - If $x = 2$ and $y = \dots$ "

If $x = 2$ and $y = 1$ what is the value of the following expression?
 $y + (xy + 4x)$

68) Assistent #69482 "69482 - If $x = 4$ and $y = \dots$ "

If $x = 4$ and $y = 1$ what is the value of the following expression?
 $y + (xy + 4x)$

69) Assistent #69483 "69483 - If $x = 6$ and $y = \dots$ "

If $x = 6$ and $y = 9$ what is the value of the following expression?
 $y + (xy + 2x)$

70) Assistent #69484 "69484 - If $x = 3$ and $y = \dots$ "

If $x = 3$ and $y = 5$ what is the value of the following expression?
 $y + (xy + 3x)$

71) Assistent #69485 "69485 - Substitution - Negative - Add + Multiply - Difficult"

If y is equal to -2
then what is the value of $19 + 2y$?

72) Assistent #69486 "69486 - Substitution - Negative - Add + Multiply - Difficult"

If y is equal to -2

then what is the value of $15 + 4y$?

73) Assistent #69487 "69487 - Substitution - Negative - Add + Multiply - Difficult"

If y is equal to -5

then what is the value of $9 + 5y$?

74) Assistent #69488 "69488 - Substitution - Negative - Add + Multiply - Difficult"

If y is equal to -8

then what is the value of $2 + 4y$?

75) Assistent #69489 "69489 - Substitution - Negative - Add + Multiply - Difficult"

If y is equal to -4

then what is the value of $6 + 4y$?

76) Assistent #69490 "69490 - Substitution - Negative - Add + Multiply - Difficult"

If y is equal to -7

then what is the value of $19 + 5y$?

77) Assistent #69491 "69491 - Substitution - Negative - Add + Multiply - Difficult"

If y is equal to -4

then what is the value of $15 + 4y$?

78) Assistent #69492 "69492 - Substitution - Negative - Add + Multiply - Difficult"

If y is equal to -2

then what is the value of $15 + 5y$?

79) Assistent #69493 "69493 - Substitution - Negative - Add + Multiply - Difficult"

If y is equal to -10

then what is the value of $12 + 5y$?

80) Assistent #69494 "69494 - Substitution - Negative - Add + Multiply - Difficult"

If y is equal to -6

then what is the value of $18 + 2y$?

81) Assistent #69495 "69495 - Substitution - Negative - Subtract + Multiply - Difficult"

If x is equal to -5

then what is the value of $4 - 1*x$?

82) Assistent #69496 "69496 - Substitution - Negative - Subtract + Multiply - Difficult"

If x is equal to -4

then what is the value of $17 - 1*x$?

83) Assistent #69497 "69497 - Substitution - Negative - Subtract + Multiply - Difficult"

If x is equal to -8
then what is the value of $8 - 3x$?

84) Assistent #69498 "69498 - Substitution - Negative - Subtract + Multiply - Difficult"

If x is equal to -9
then what is the value of $16 - 2x$?

85) Assistent #69499 "69499 - Substitution - Negative - Subtract + Multiply - Difficult"

If x is equal to -5
then what is the value of $11 - 1x$?

86) Assistent #69500 "69500 - Substitution - Negative - Subtract + Multiply - Difficult"

If x is equal to -3
then what is the value of $14 - 1x$?

87) Assistent #69501 "69501 - Substitution - Negative - Subtract + Multiply - Difficult"

If x is equal to -2
then what is the value of $3 - 3x$?

88) Assistent #69502 "69502 - Substitution - Negative - Subtract + Multiply - Difficult"

If x is equal to -10
then what is the value of $14 - 2x$?

89) Assistent #69503 "69503 - Substitution - Negative - Subtract + Multiply - Difficult"

If x is equal to -6
then what is the value of $16 - 4x$?

90) Assistent #69504 "69504 - Substitution - Negative - Subtract + Multiply - Difficult"

If x is equal to -6

then what is the value of $8 - 1 \cdot x$?

91) Assistent #69505 "69505 - Substitution - Negative - Subtract + Multiply - Difficult"

If y is equal to -2

then what is the value of $18 - 4y$?

92) Assistent #69506 "69506 - Substitution - Negative - Subtract + Multiply - Difficult"

If y is equal to -2

then what is the value of $17 - 2y$?

93) Assistent #69507 "69507 - Substitution - Negative - Subtract + Multiply - Difficult"

If y is equal to -8

then what is the value of $13 - 4y$?

94) Assistent #69508 "69508 - Substitution - Negative - Subtract + Multiply - Difficult"

If y is equal to -10

then what is the value of $15 - 2y$?

95) Assistent #69509 "69509 - Substitution - Negative - Subtract + Multiply - Difficult"

If y is equal to -6

then what is the value of $12 - 4y$?

96) Assistent #69510 "69510 - Substitution - Negative - Subtract + Multiply - Difficult"

If y is equal to -2

then what is the value of $19 - 5y$?

97) Assistent #69511 "69511 - Substitution - Negative - Subtract + Multiply - Difficult"

If y is equal to -5

then what is the value of $16 - 5y$?

98) Assistent #69512 "69512 - Substitution - Negative - Subtract + Multiply - Difficult"

If y is equal to -7

then what is the value of $17 - 3y$?

99) Assistent #69513 "69513 - Substitution - Negative - Subtract + Multiply - Difficult"

If y is equal to -8

then what is the value of $16 - 3y$?

100) Assistent #69514 "69514 - Substitution - Negative - Subtract + Multiply - Difficult"

If y is equal to -10

then what is the value of $15 - 5y$?

1) Assistent #64197 "64197 - 57849 - Recognizing Linear Functions"

Choose the answer that describes the two graphs shown below:

A) B)

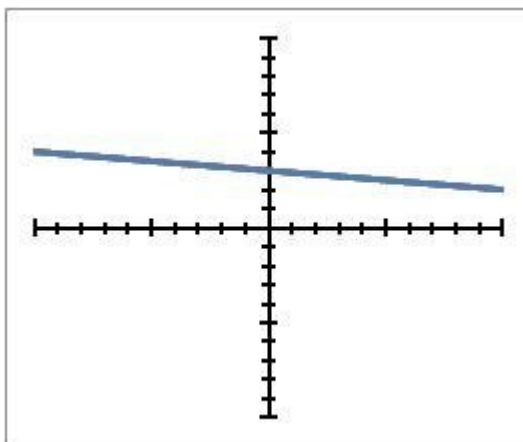
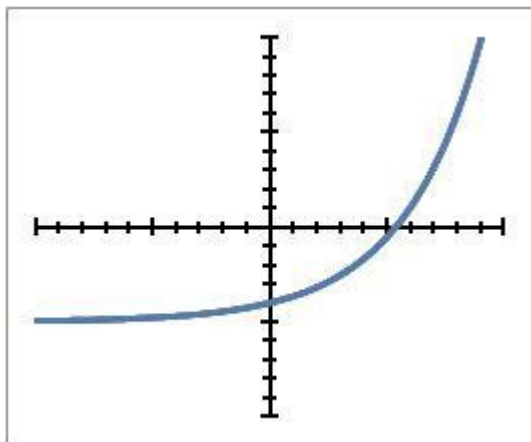

Both are Linear

Neither are Linear

A is Linear but B is not

B is Linear but A is not

2) Assistent #64198 "64198 - 57849 - Recognizing Linear Functions"

Choose the answer that describes the two graphs shown below:

A) B)

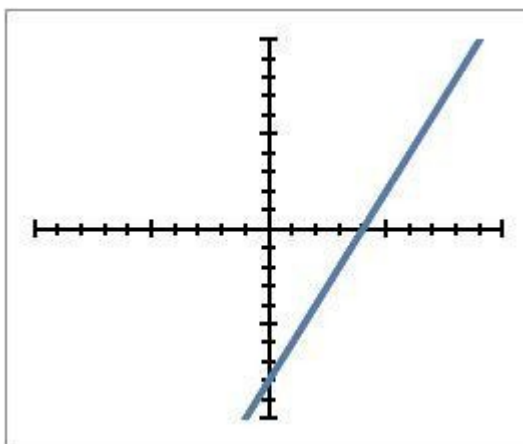
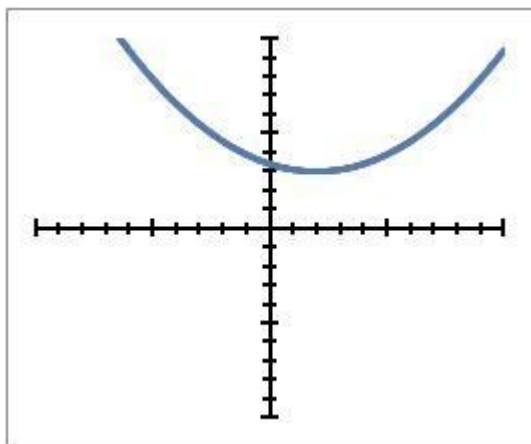

Both are Linear

Neither are Linear

A is Linear but B is not

B is Linear but A is not

3) Assistent #64199 "64199 - 57849 - Recognizing Linear Functions"

Choose the answer that describes the two graphs shown below:

A)

B)

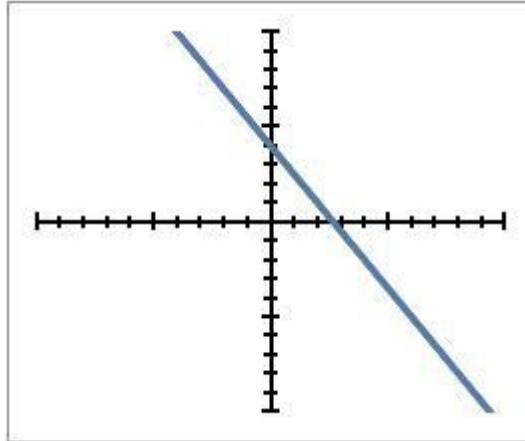
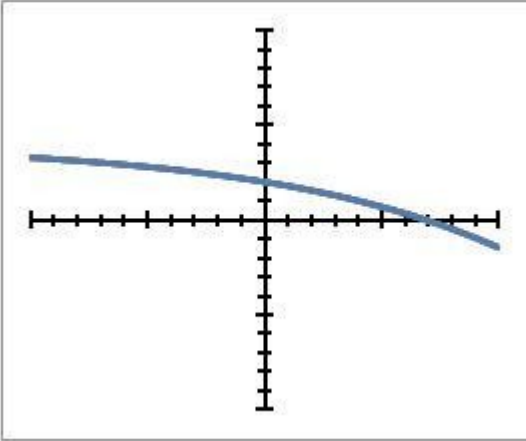

Both are Linear

Neither are Linear

A is Linear but B is not

B is Linear but A is not

4) Assistent #64200 "64200 - 57849 - Recognizing Linear Functions"

Choose the answer that describes the two graphs shown below:

A)

B)

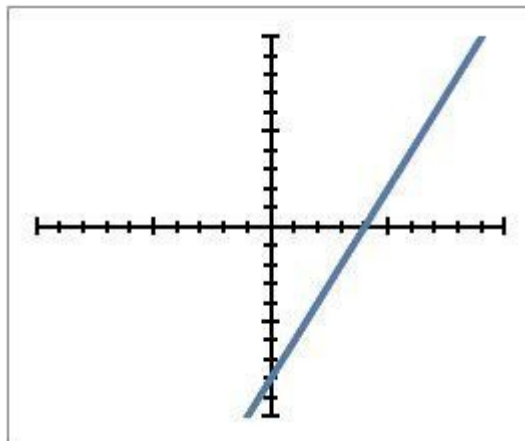
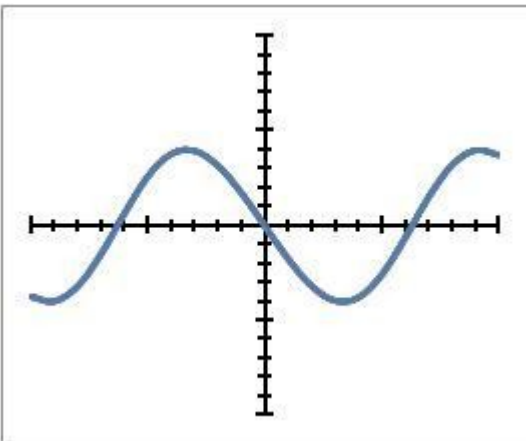

Both are Linear

Neither are Linear

A is Linear but B is not
B is Linear but A is not

5) Assistentment #64201 "64201 - 57849 - Recognizing Linear Functions"

Choose the answer that describes the two graphs shown below:

A) **B)**

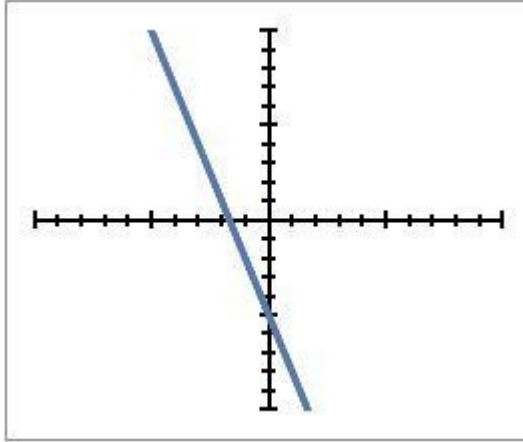
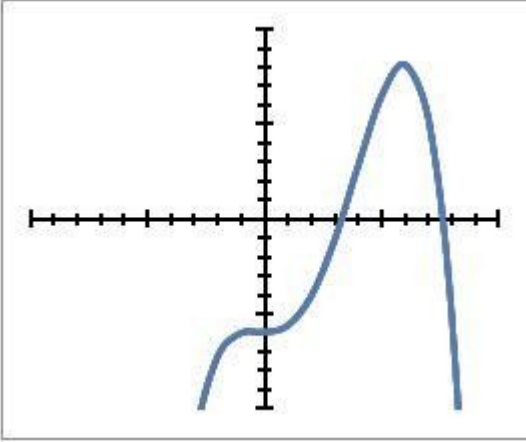

Both are Linear
Neither are Linear
A is Linear but B is not
B is Linear but A is not

6) Assistentment #64202 "64202 - 57849 - Recognizing Linear Functions"

Choose the answer that describes the two graphs shown below:

A) **B)**

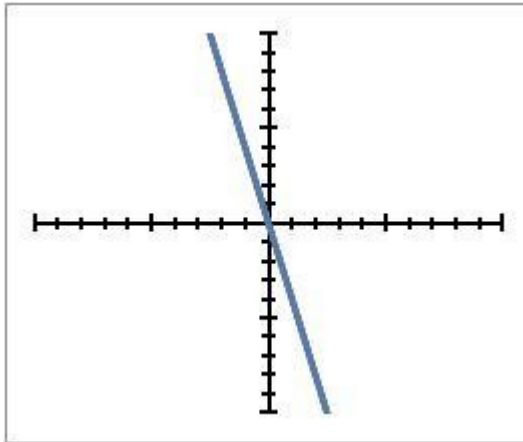
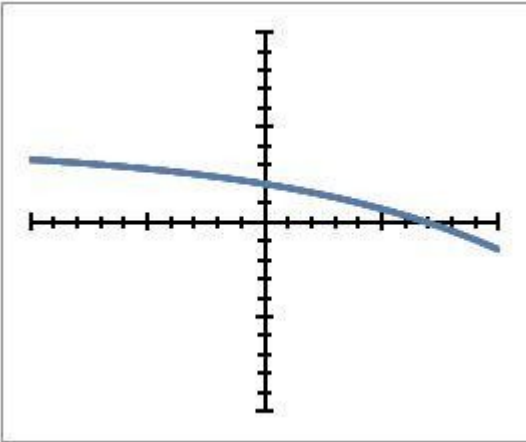

Both are Linear
Neither are Linear
A is Linear but B is not
B is Linear but A is not

7) Assistentment #64203 "64203 - 57849 - Recognizing Linear Functions"

Choose the answer that describes the two graphs shown below:

A)

B)

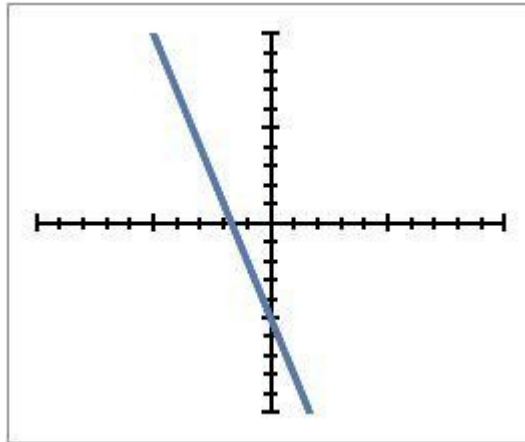
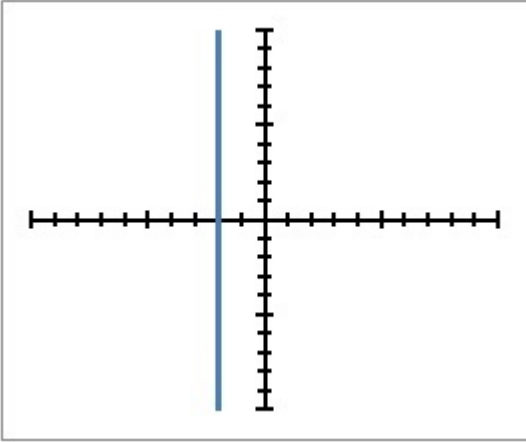

Both are Linear

Neither are Linear

A is Linear but B is not

B is Linear but A is not

8) Assistentment #64204 "64204 - 57849 - Recognizing Linear Functions"

Choose the answer that describes the two graphs shown below:

A)

B)

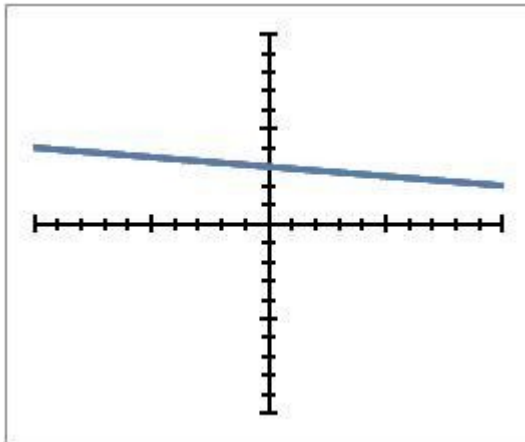
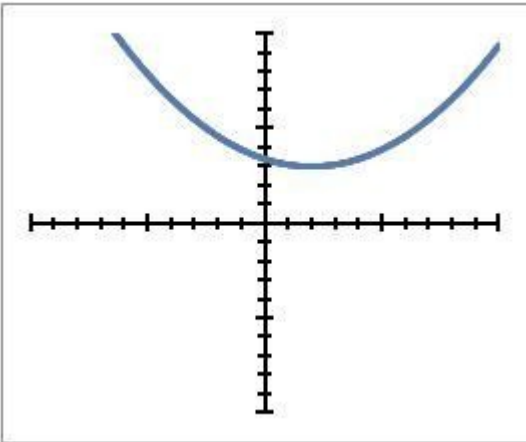

Both are Linear

Neither are Linear

A is Linear but B is not

B is Linear but A is not

9) Assistentment #64205 "64205 - 57849 - Recognizing Linear Functions"

Choose the answer that describes the two graphs shown below:

A)

B)

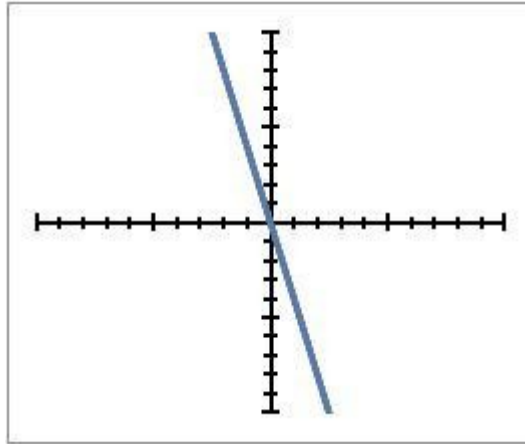
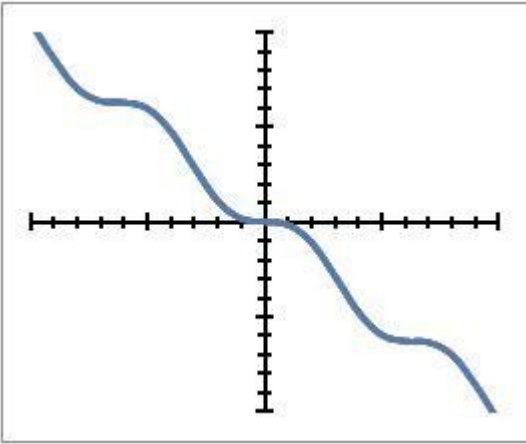

- Both are Linear
- Neither are Linear
- A is Linear but B is not
- B is Linear but A is not

10) Assistentment #64206 "64206 - 57849 - Recognizing Linear Functions"

Choose the answer that describes the two graphs shown below:

A)

B)

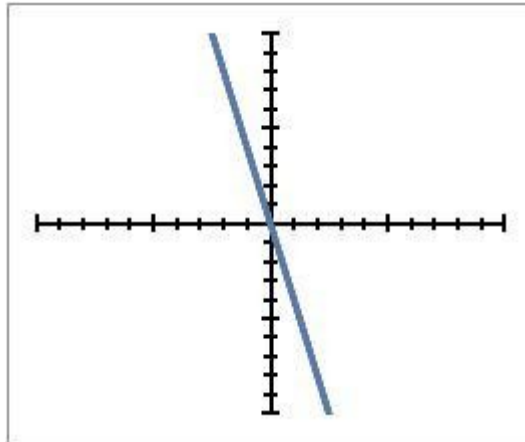
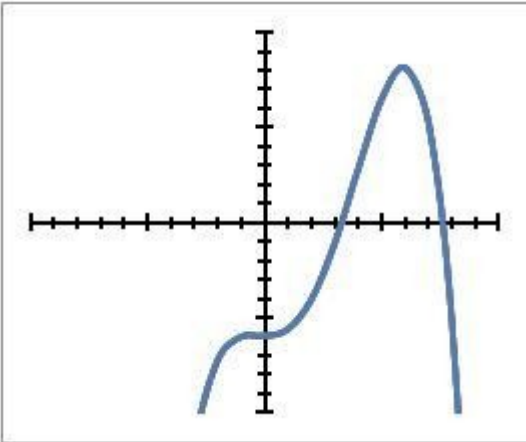

- Both are Linear
- Neither are Linear
- A is Linear but B is not
- B is Linear but A is not

11) Assistentment #64207 "64207 - 57849 - Recognizing Linear Functions"

Choose the answer that describes the two graphs shown below:

A)

B)

Both are Linear

Neither are Linear

A is Linear but B is not

B is Linear but A is not

12) Assisment #64208 "64208 - 57849 - Recognizing Linear Functions"

Choose the answer that describes the two graphs shown below:

A)

B)

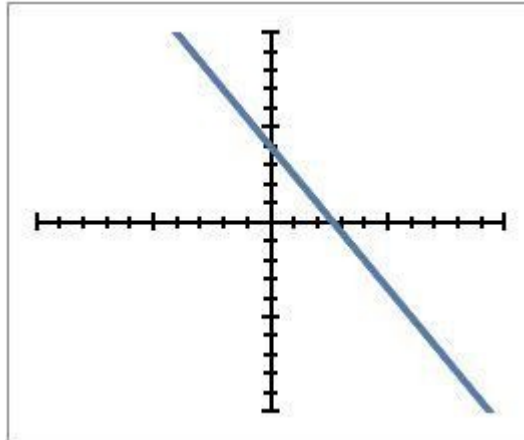
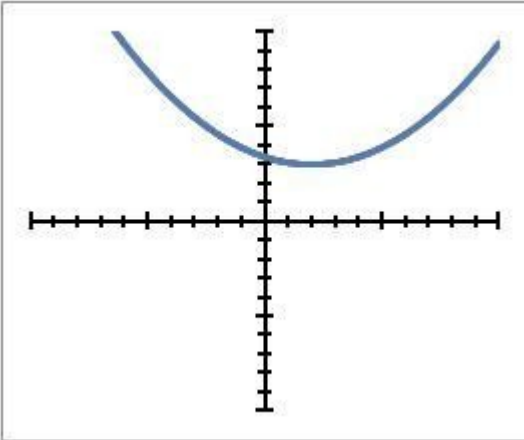

Both are Linear

Neither are Linear

A is Linear but B is not

B is Linear but A is not

13) Assisment #64209 "64209 - 57849 - Recognizing Linear Functions"

Choose the answer that describes the two graphs shown below:

A)

B)

Both are Linear

Neither are Linear

A is Linear but B is not

B is Linear but A is not

14) Assisment #64210 "64210 - 57849 - Recognizing Linear Functions"

Choose the answer that describes the two graphs shown below:

A)

B)

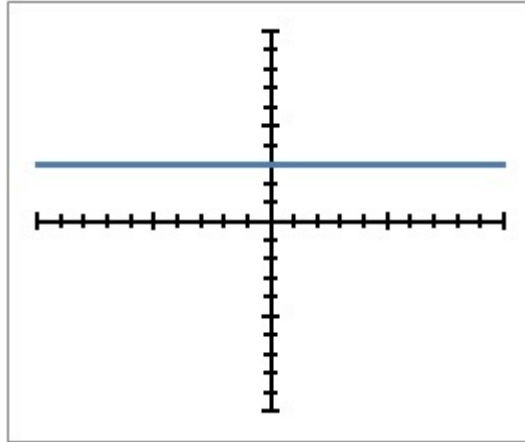
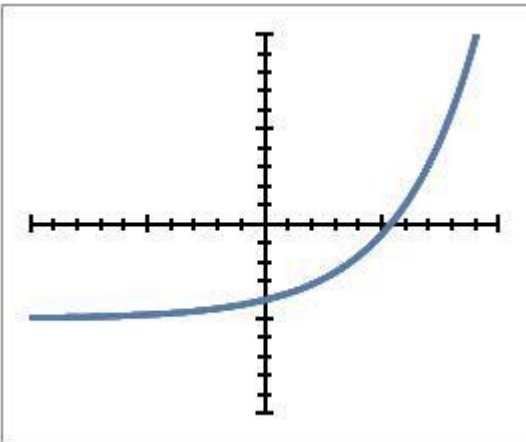

Both are Linear

Neither are Linear

A is Linear but B is not

B is Linear but A is not

15) Assisment #64211 "64211 - 57849 - Recognizing Linear Functions"

Choose the answer that describes the two graphs shown below:

A)

B)

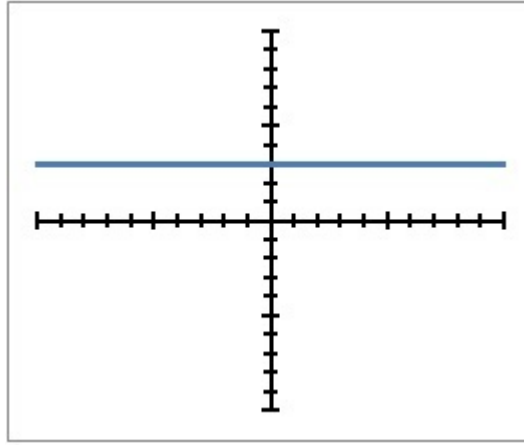
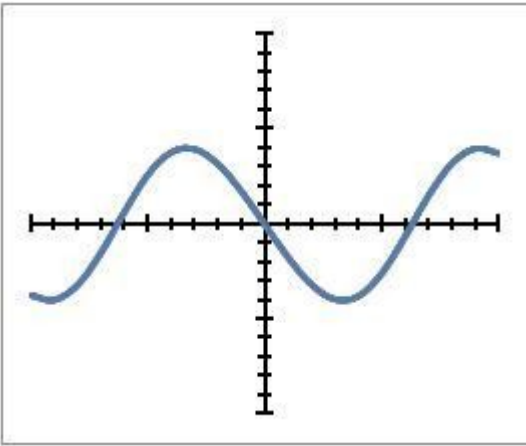

- Both are Linear
- Neither are Linear
- A is Linear but B is not
- B is Linear but A is not

16) Assisment #64212 "64212 - 57849 - Recognizing Linear Functions"

Choose the answer that describes the two graphs shown below:

A)

B)

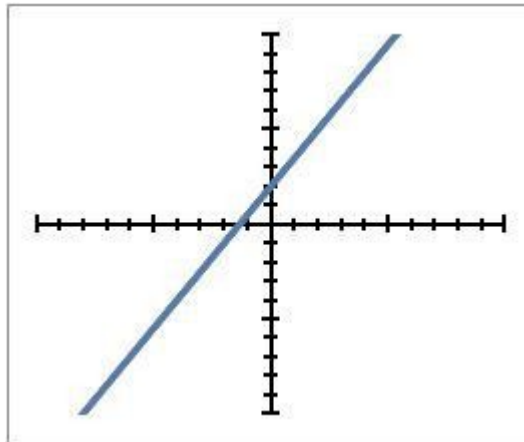
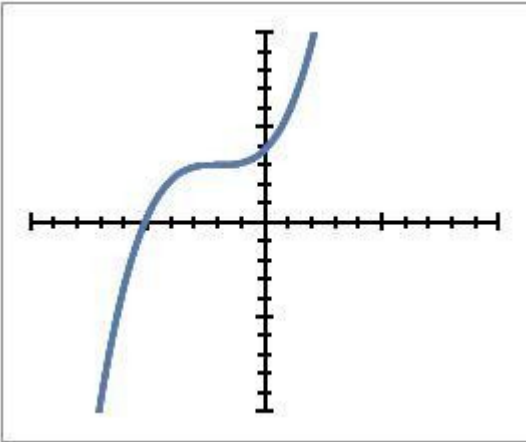

- Both are Linear
- Neither are Linear
- A is Linear but B is not
- B is Linear but A is not

17) Assisment #64213 "64213 - 57849 - Recognizing Linear Functions"

Choose the answer that describes the two graphs shown below:

A)

B)

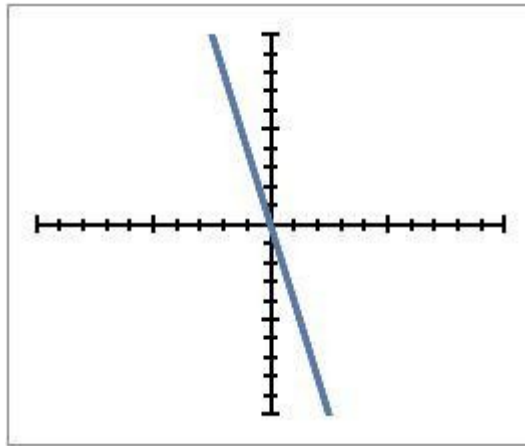
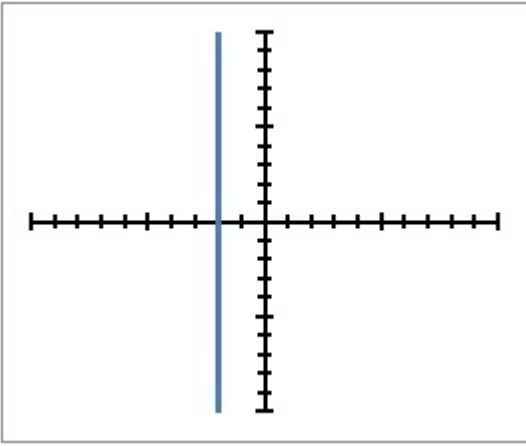

- Both are Linear
- Neither are Linear
- A is Linear but B is not
- B is Linear but A is not

18) Assisment #64214 "64214 - 57849 - Recognizing Linear Functions"

Choose the answer that describes the two graphs shown below:

A) **B)**

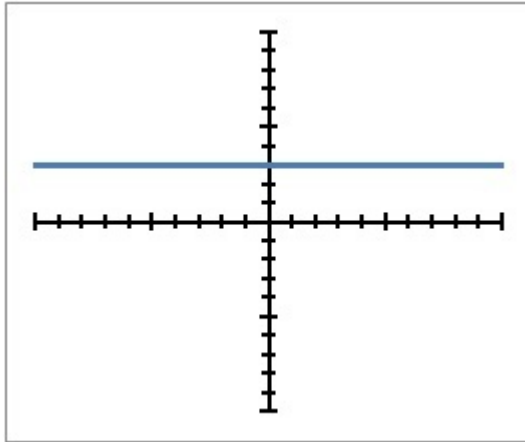
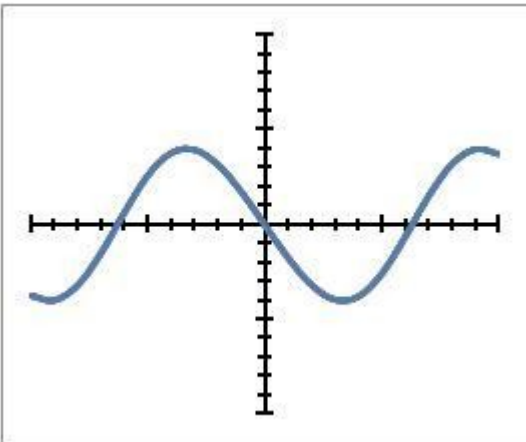

- Both are Linear
- Neither are Linear
- A is Linear but B is not
- B is Linear but A is not

19) Assisment #64215 "64215 - 57849 - Recognizing Linear Functions"

Choose the answer that describes the two graphs shown below:

A) **B)**

Both are Linear

Neither are Linear

A is Linear but B is not

B is Linear but A is not

20) Assistentment #64216 "64216 - 57849 - Recognizing Linear Functions"

Choose the answer that describes the two graphs shown below:

A)

B)

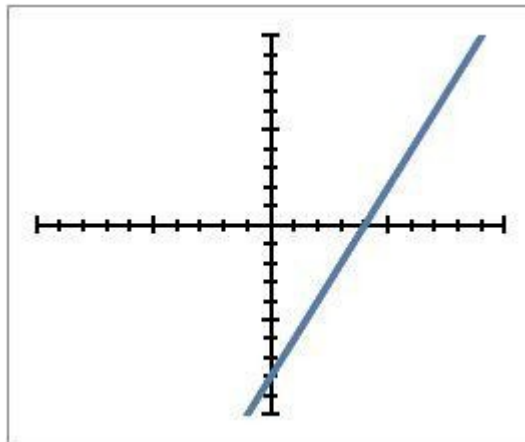
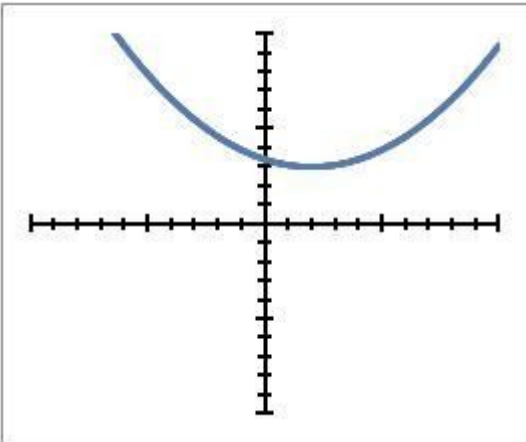

Both are Linear

Neither are Linear

A is Linear but B is not

B is Linear but A is not

21) Assistentment #64217 "64217 - 57850 - Recognizing Linear Functions"

Choose the answer that describes the two graphs shown below:

A)

B)

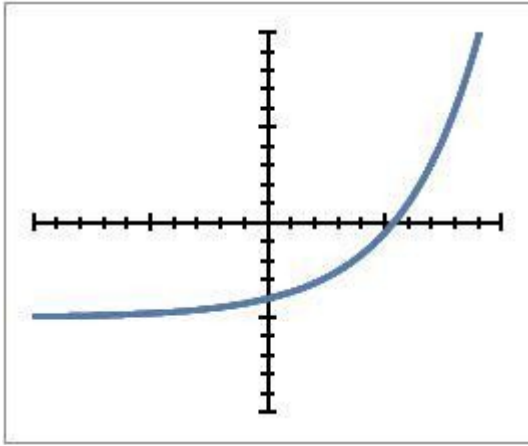
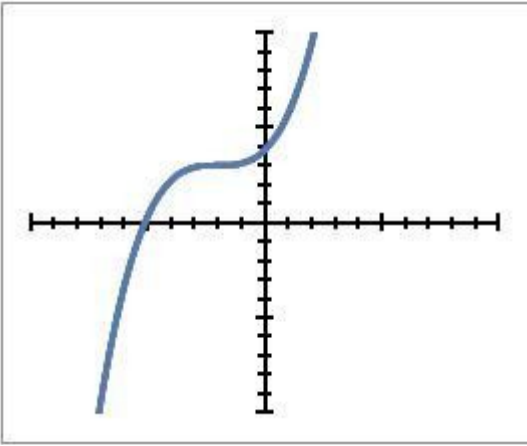

- Both are Linear
- Neither are Linear
- A is Linear but B is not
- B is Linear but A is not

22) Assisment #64218 "64218 - 57850 - Recognizing Linear Functions"

Choose the answer that describes the two graphs shown below:

A)

B)

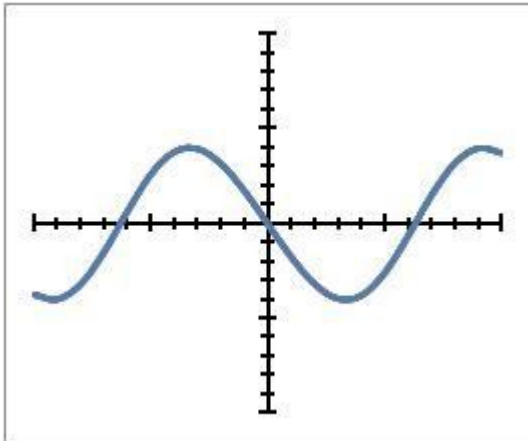
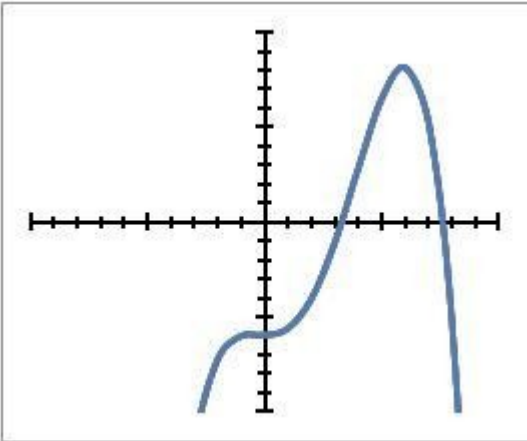

- Both are Linear
- Neither are Linear
- A is Linear but B is not
- B is Linear but A is not

23) Assisment #64219 "64219 - 57850 - Recognizing Linear Functions"

Choose the answer that describes the two graphs shown below:

A)

B)

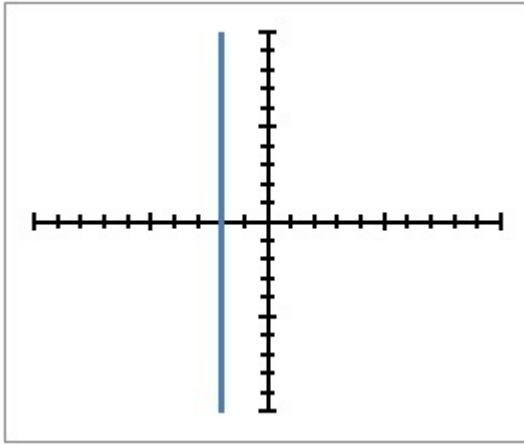
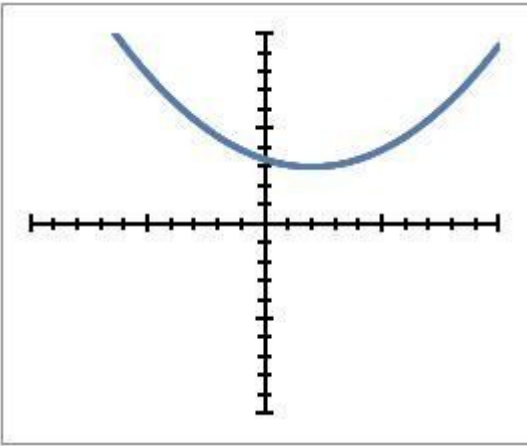

- Both are Linear
- Neither are Linear
- A is Linear but B is not
- B is Linear but A is not

24) Assistentment #64220 "64220 - 57850 - Recognizing Linear Functions"

Choose the answer that describes the two graphs shown below:

A)

B)

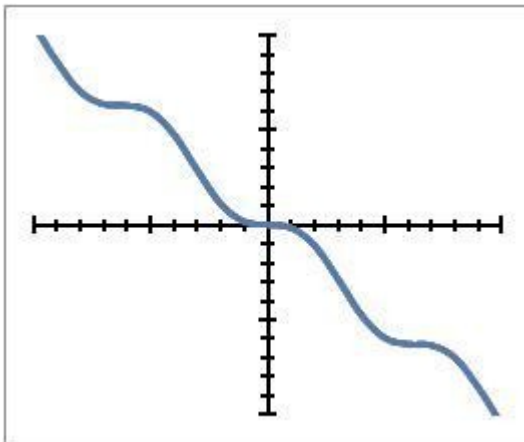
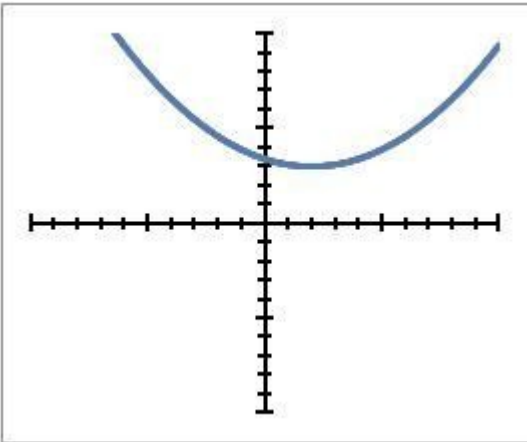

- Both are Linear
- Neither are Linear
- A is Linear but B is not
- B is Linear but A is not

25) Assistentment #64221 "64221 - 57850 - Recognizing Linear Functions"

Choose the answer that describes the two graphs shown below:

A)

B)

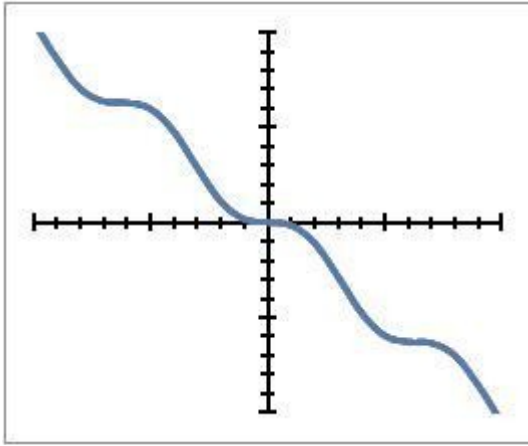
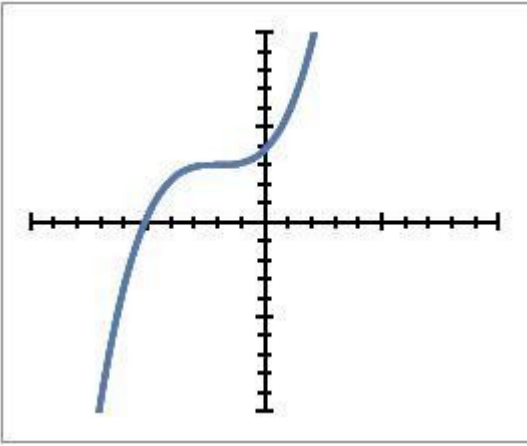

- Both are Linear
- Neither are Linear
- A is Linear but B is not
- B is Linear but A is not

26) Assisment #64222 "64222 - 57850 - Recognizing Linear Functions"

Choose the answer that describes the two graphs shown below:

A)

B)

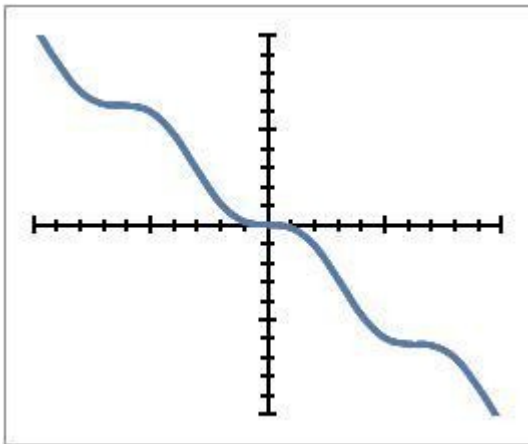
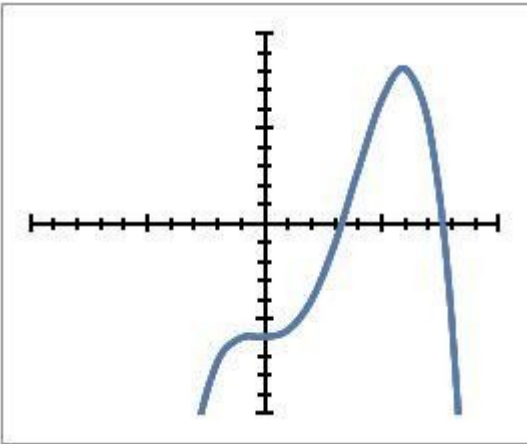

- Both are Linear
- Neither are Linear
- A is Linear but B is not
- B is Linear but A is not

27) Assisment #64223 "64223 - 57850 - Recognizing Linear Functions"

Choose the answer that describes the two graphs shown below:

A)

B)

Both are Linear

Neither are Linear

A is Linear but B is not

B is Linear but A is not

28) Assisment #64224 "64224 - 57850 - Recognizing Linear Functions"

Choose the answer that describes the two graphs shown below:

A)

B)

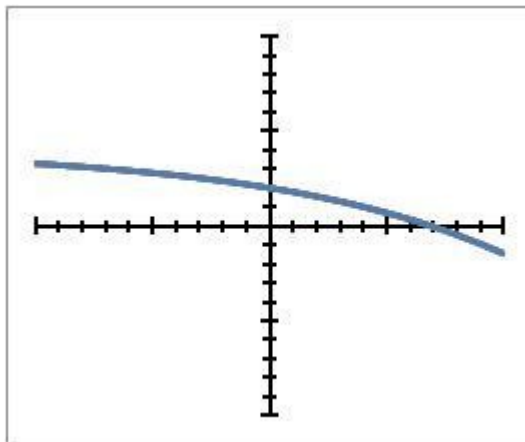
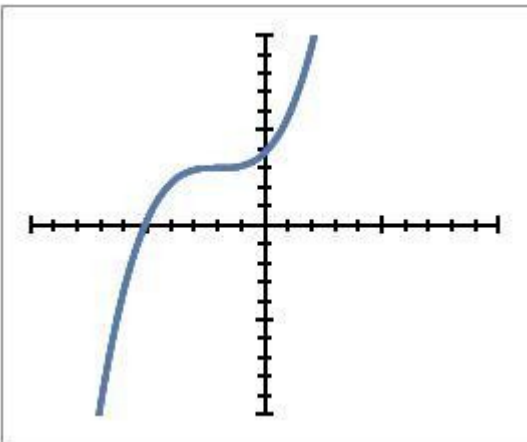

Both are Linear

Neither are Linear

A is Linear but B is not

B is Linear but A is not

29) Assisment #64225 "64225 - 57850 - Recognizing Linear Functions"

Choose the answer that describes the two graphs shown below:

A)

B)

Both are Linear

Neither are Linear

A is Linear but B is not

B is Linear but A is not

30) Assisment #64226 "64226 - 57850 - Recognizing Linear Functions"

Choose the answer that describes the two graphs shown below:

A)

B)

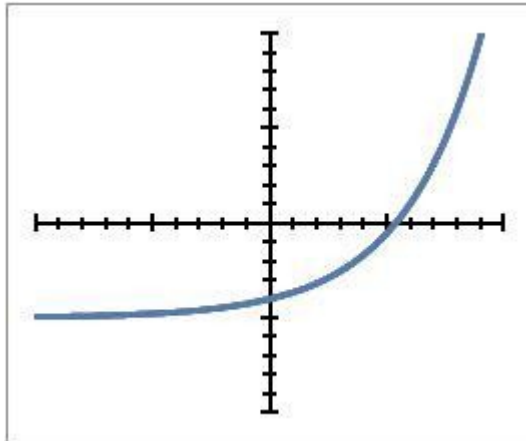
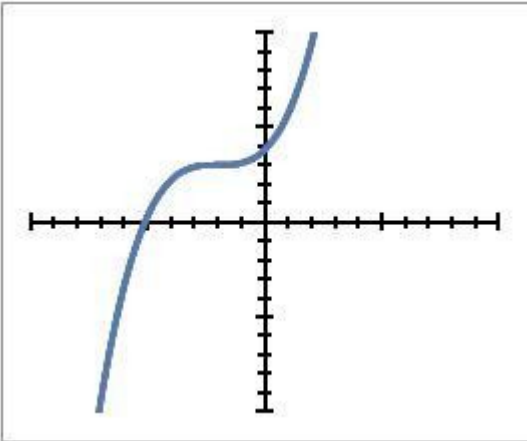

Both are Linear

Neither are Linear

A is Linear but B is not

B is Linear but A is not

31) Assisment #64227 "64227 - 57850 - Recognizing Linear Functions"

Choose the answer that describes the two graphs shown below:

A)

B)

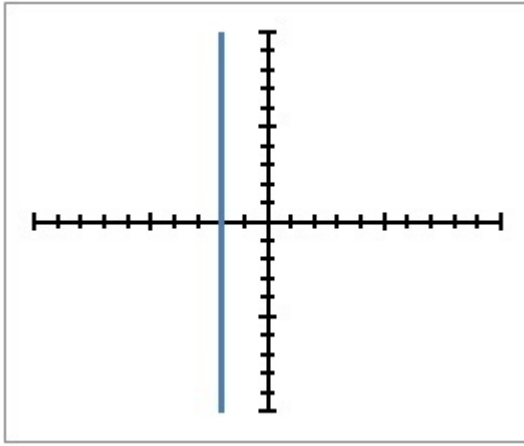
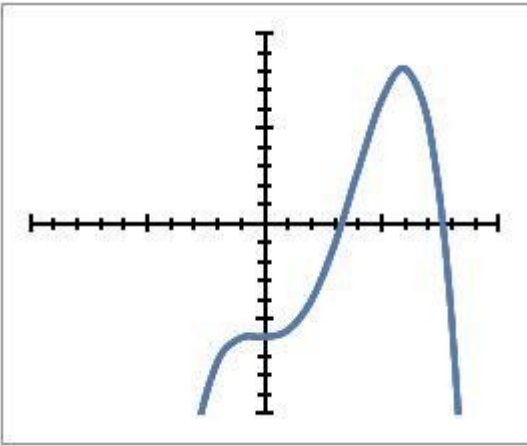

- Both are Linear
- Neither are Linear
- A is Linear but B is not
- B is Linear but A is not

32) Assisment #64228 "64228 - 57850 - Recognizing Linear Functions"

Choose the answer that describes the two graphs shown below:

A)

B)

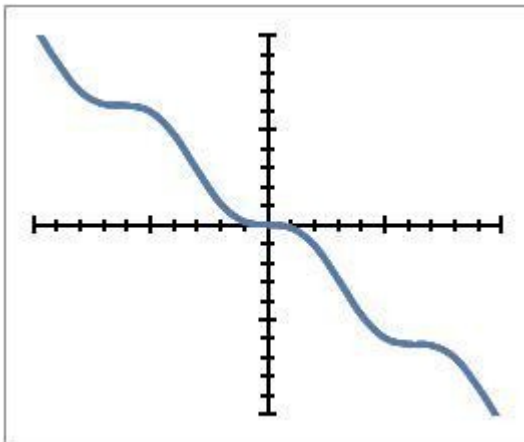
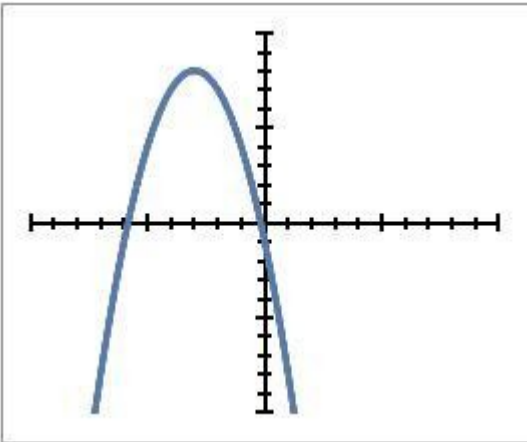

- Both are Linear
- Neither are Linear
- A is Linear but B is not
- B is Linear but A is not

33) Assisment #64229 "64229 - 57850 - Recognizing Linear Functions"

Choose the answer that describes the two graphs shown below:

A)

B)

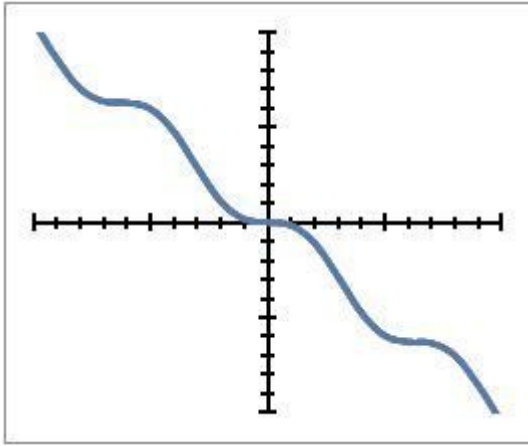
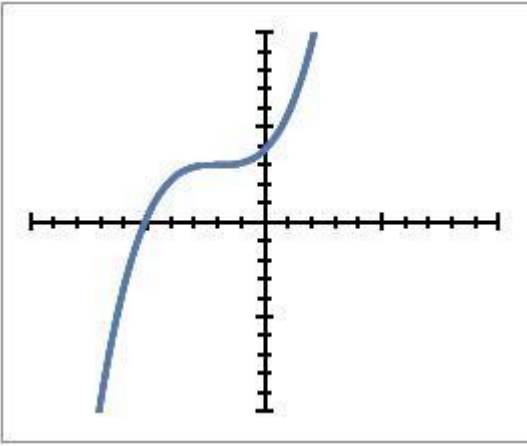

- Both are Linear
- Neither are Linear
- A is Linear but B is not
- B is Linear but A is not

34) Assisment #64230 "64230 - 57850 - Recognizing Linear Functions"

Choose the answer that describes the two graphs shown below:

A)

B)

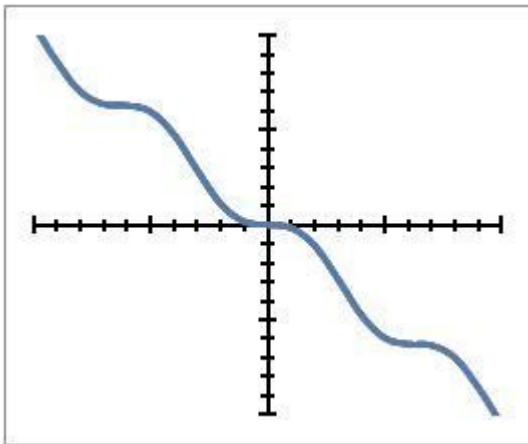
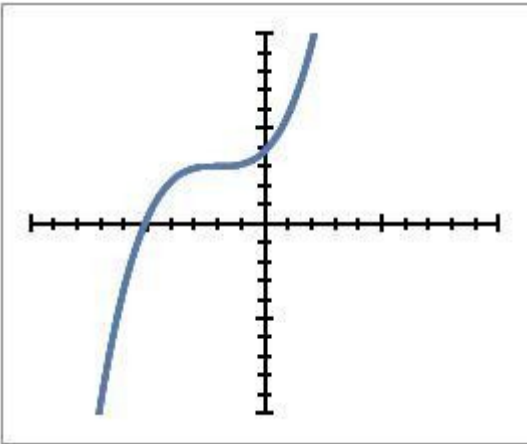

- Both are Linear
- Neither are Linear
- A is Linear but B is not
- B is Linear but A is not

35) Assisment #64231 "64231 - 57850 - Recognizing Linear Functions"

Choose the answer that describes the two graphs shown below:

A)

B)

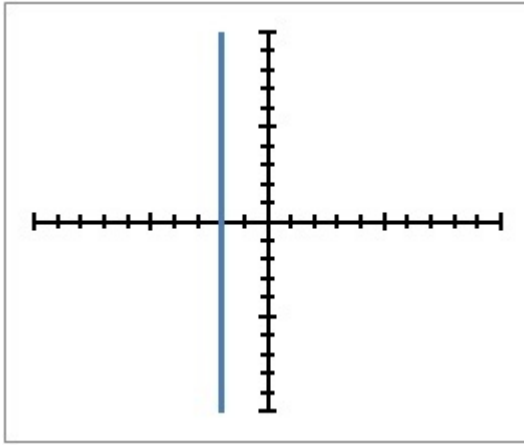
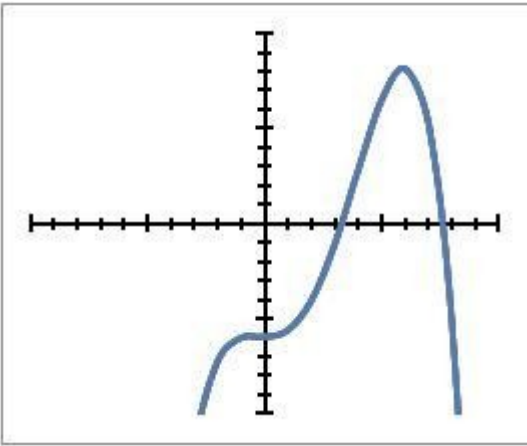

- Both are Linear
- Neither are Linear
- A is Linear but B is not
- B is Linear but A is not

36) Assisment #64232 "64232 - 57850 - Recognizing Linear Functions"

Choose the answer that describes the two graphs shown below:

A)

B)

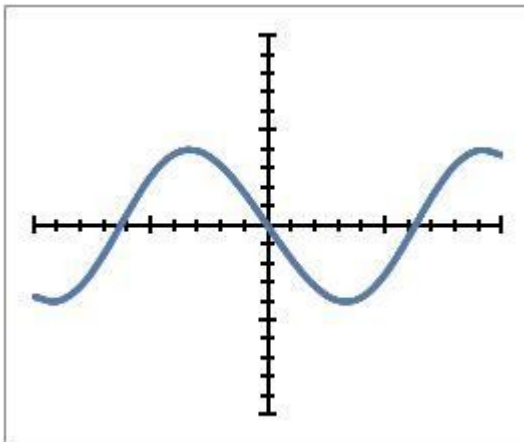
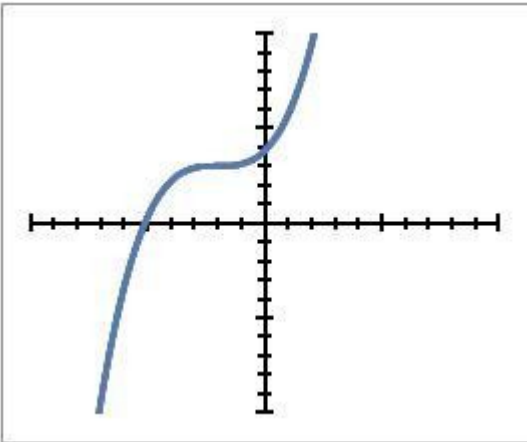

- Both are Linear
- Neither are Linear
- A is Linear but B is not
- B is Linear but A is not

37) Assisment #64233 "64233 - 57850 - Recognizing Linear Functions"

Choose the answer that describes the two graphs shown below:

A)

B)

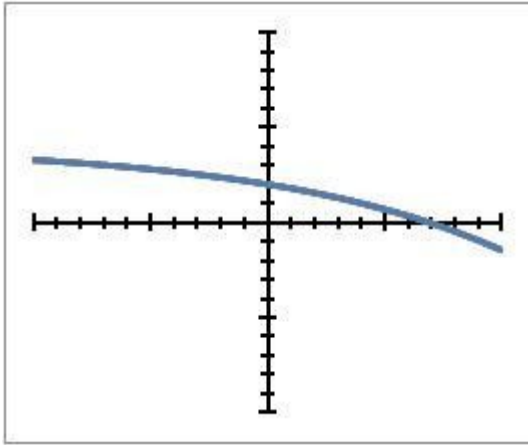
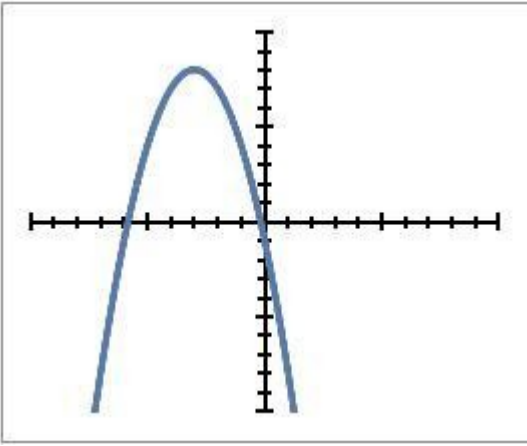

- Both are Linear
- Neither are Linear
- A is Linear but B is not
- B is Linear but A is not

38) Assisment #64234 "64234 - 57850 - Recognizing Linear Functions"

Choose the answer that describes the two graphs shown below:

A)

B)

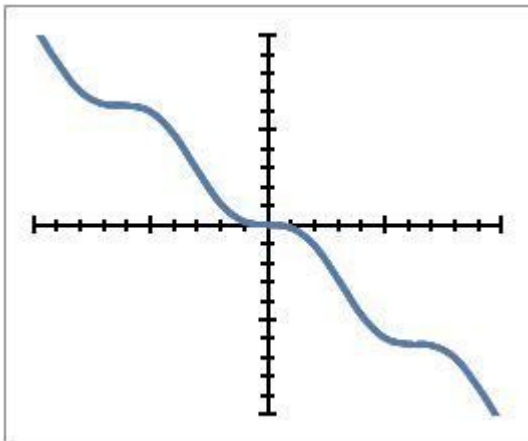
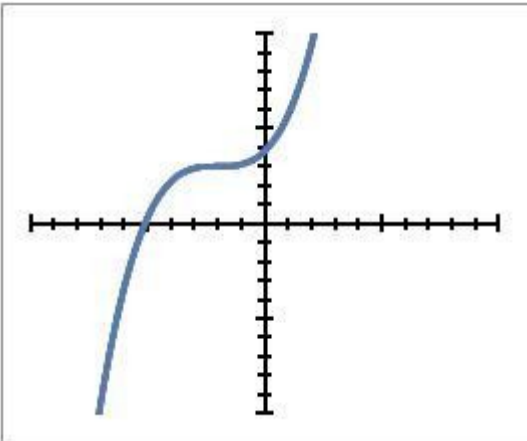

- Both are Linear
- Neither are Linear
- A is Linear but B is not
- B is Linear but A is not

39) Assisment #64235 "64235 - 57850 - Recognizing Linear Functions"

Choose the answer that describes the two graphs shown below:

A)

B)

Both are Linear

Neither are Linear

A is Linear but B is not

B is Linear but A is not

40) Assisment #64236 "64236 - 57850 - Recognizing Linear Functions"

Choose the answer that describes the two graphs shown below:

A)

B)

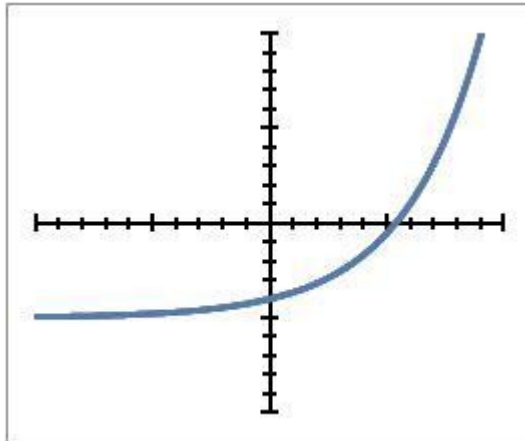
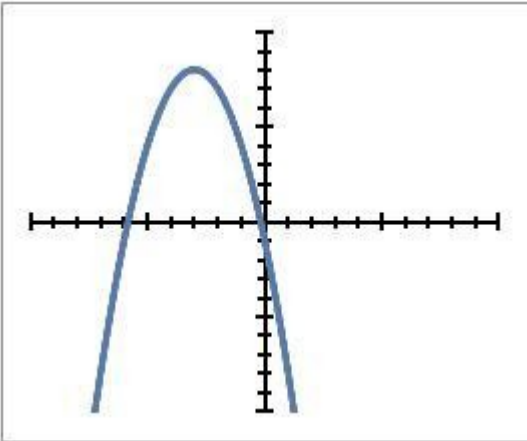

Both are Linear

Neither are Linear

A is Linear but B is not

B is Linear but A is not

41) Assisment #64237 "64237 - 57752 - Recognizing Linear Functions"

Choose the answer that describes the two graphs shown below:

A)

B)

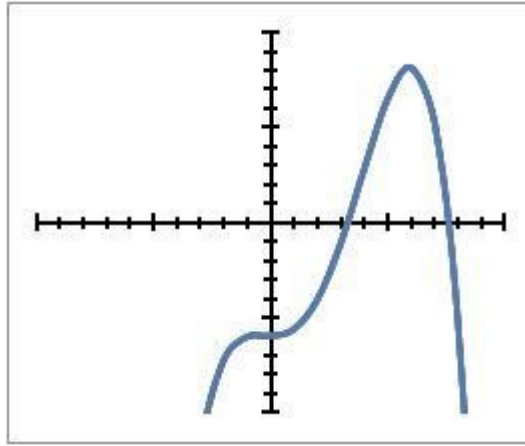
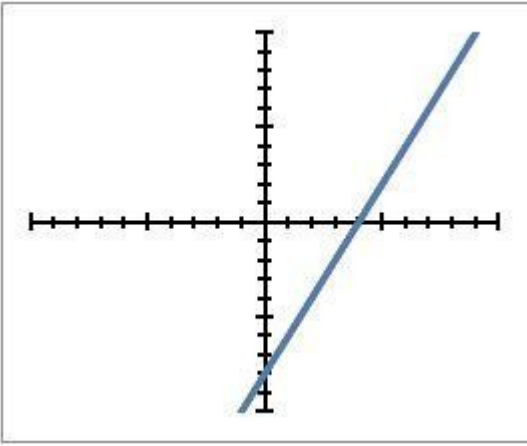

- Both are Linear
- Neither are Linear
- A is Linear but B is not
- B is Linear but A is not

42) Assisment #64238 "64238 - 57752 - Recognizing Linear Functions"

Choose the answer that describes the two graphs shown below:

- A)**
- B)**

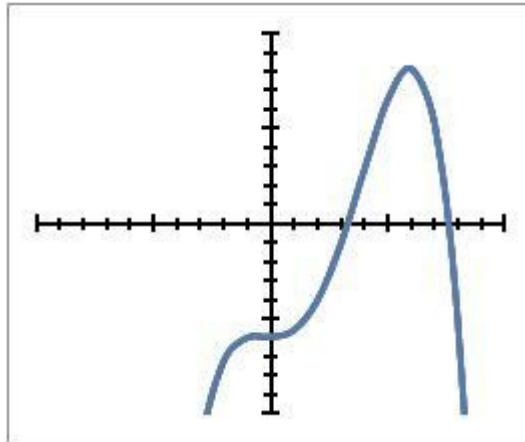
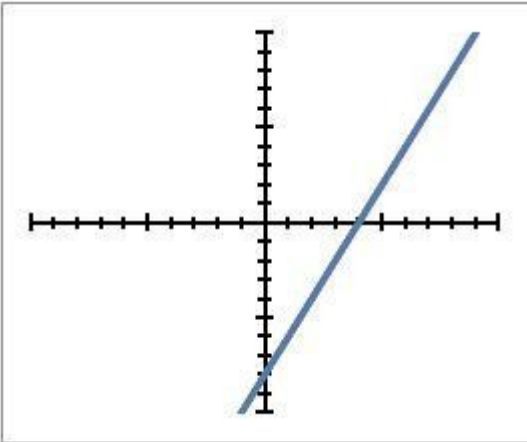

- Both are Linear
- Neither are Linear
- A is Linear but B is not
- B is Linear but A is not

43) Assisment #64239 "64239 - 57752 - Recognizing Linear Functions"

Choose the answer that describes the two graphs shown below:

- A)**
- B)**

Both are Linear

Neither are Linear

A is Linear but B is not

B is Linear but A is not

44) Assisment #64240 "64240 - 57752 - Recognizing Linear Functions"

Choose the answer that describes the two graphs shown below:

A)

B)

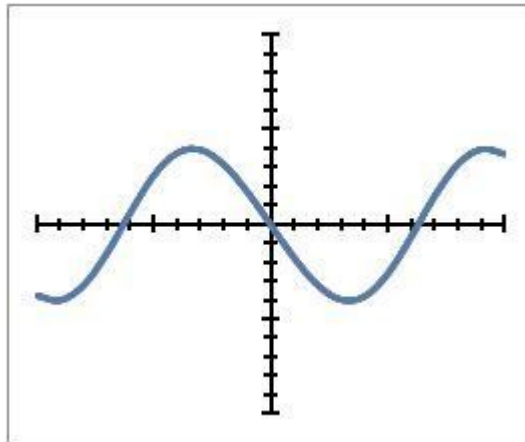
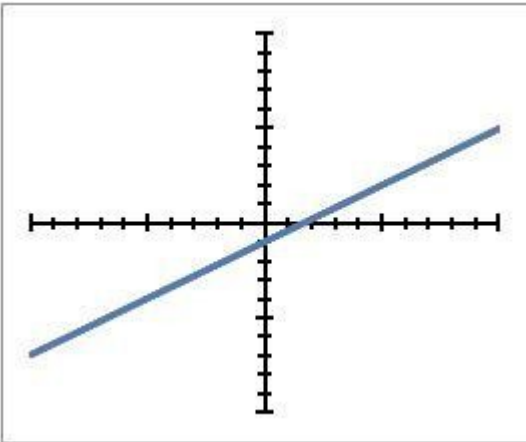

Both are Linear

Neither are Linear

A is Linear but B is not

B is Linear but A is not

45) Assisment #64241 "64241 - 57752 - Recognizing Linear Functions"

Choose the answer that describes the two graphs shown below:

A)

B)

Both are Linear

Neither are Linear

A is Linear but B is not

B is Linear but A is not

46) Assisment #64242 "64242 - 57752 - Recognizing Linear Functions"

Choose the answer that describes the two graphs shown below:

A)

B)

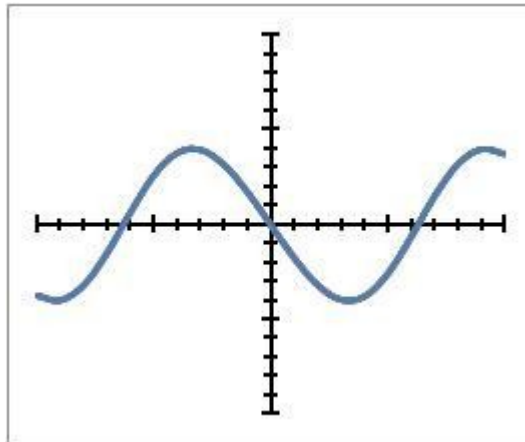
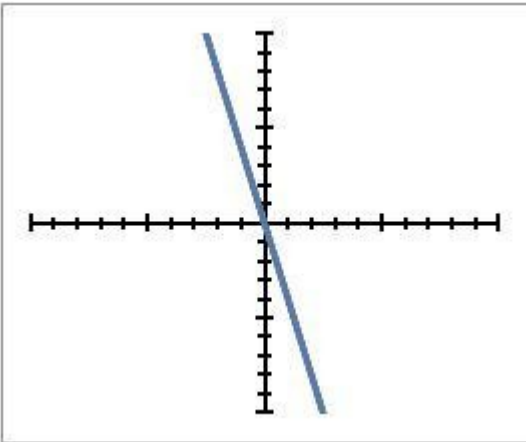

Both are Linear

Neither are Linear

A is Linear but B is not

B is Linear but A is not

47) Assisment #64243 "64243 - 57752 - Recognizing Linear Functions"

Choose the answer that describes the two graphs shown below:

A)

B)

Both are Linear

Neither are Linear

A is Linear but B is not

B is Linear but A is not

48) Assisment #64244 "64244 - 57752 - Recognizing Linear Functions"

Choose the answer that describes the two graphs shown below:

A)

B)

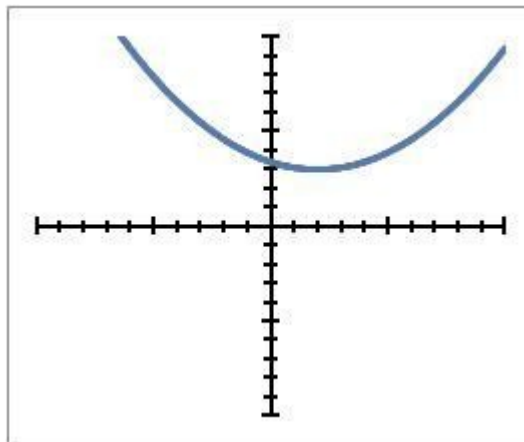
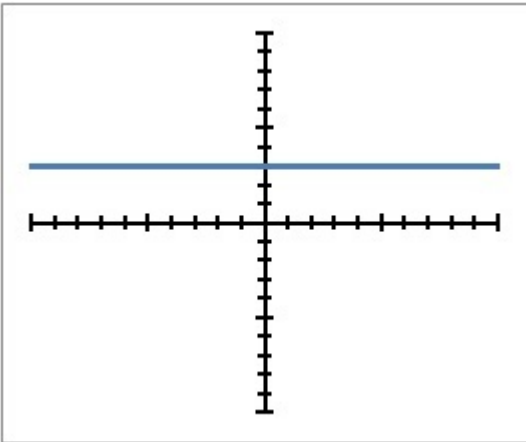

Both are Linear

Neither are Linear

A is Linear but B is not

B is Linear but A is not

49) Assisment #64245 "64245 - 57752 - Recognizing Linear Functions"

Choose the answer that describes the two graphs shown below:

A)

B)

Both are Linear

Neither are Linear

A is Linear but B is not

B is Linear but A is not

50) Assistentment #64246 "64246 - 57752 - Recognizing Linear Functions"

Choose the answer that describes the two graphs shown below:

A)

B)

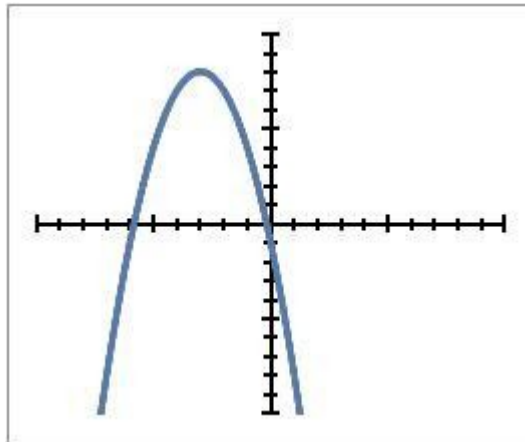
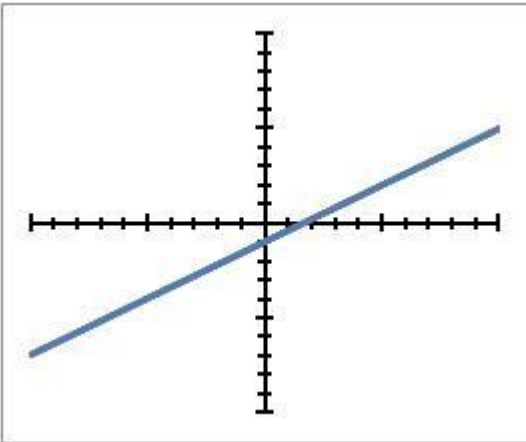

Both are Linear

Neither are Linear

A is Linear but B is not

B is Linear but A is not

51) Assistentment #64247 "64247 - 57752 - Recognizing Linear Functions"

Choose the answer that describes the two graphs shown below:

A)

B)

Both are Linear

Neither are Linear

A is Linear but B is not

B is Linear but A is not

52) Assisment #64248 "64248 - 57752 - Recognizing Linear Functions"

Choose the answer that describes the two graphs shown below:

A)

B)

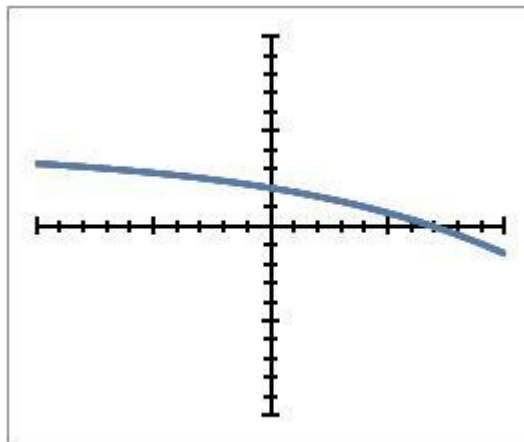
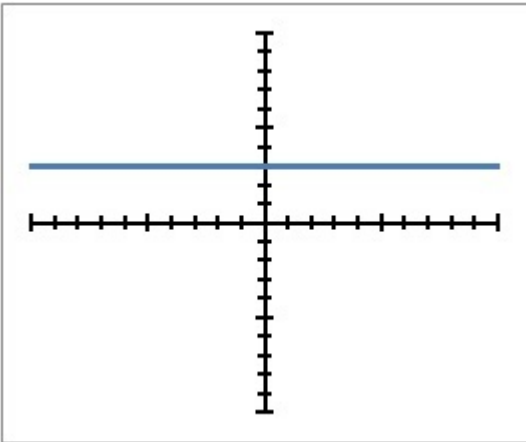

Both are Linear

Neither are Linear

A is Linear but B is not

B is Linear but A is not

53) Assisment #64249 "64249 - 57752 - Recognizing Linear Functions"

Choose the answer that describes the two graphs shown below:

A)

B)

Both are Linear

Neither are Linear

A is Linear but B is not

B is Linear but A is not

54) Assistentment #64250 "64250 - 57752 - Recognizing Linear Functions"

Choose the answer that describes the two graphs shown below:

A)

B)

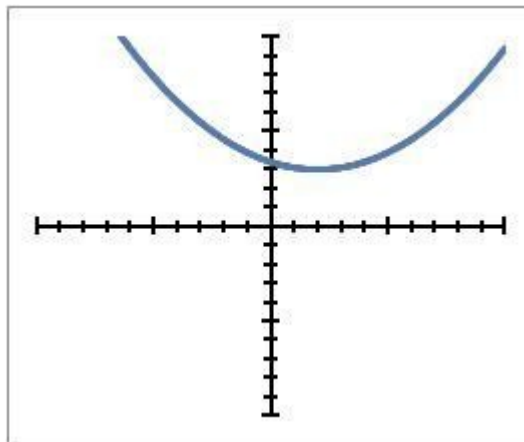
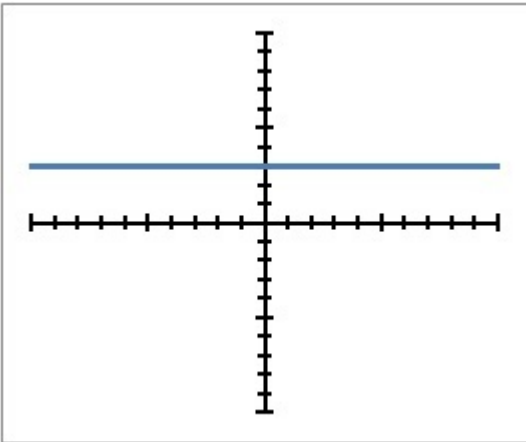

Both are Linear

Neither are Linear

A is Linear but B is not

B is Linear but A is not

55) Assistentment #64251 "64251 - 57752 - Recognizing Linear Functions"

Choose the answer that describes the two graphs shown below:

A)

B)

Both are Linear

Neither are Linear

A is Linear but B is not

B is Linear but A is not

56) Assistentment #64252 "64252 - 57752 - Recognizing Linear Functions"

Choose the answer that describes the two graphs shown below:

A)

B)

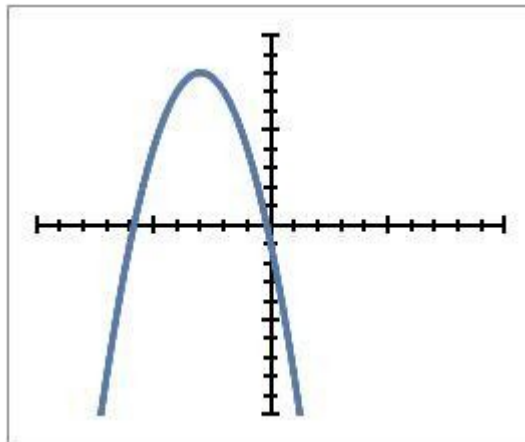
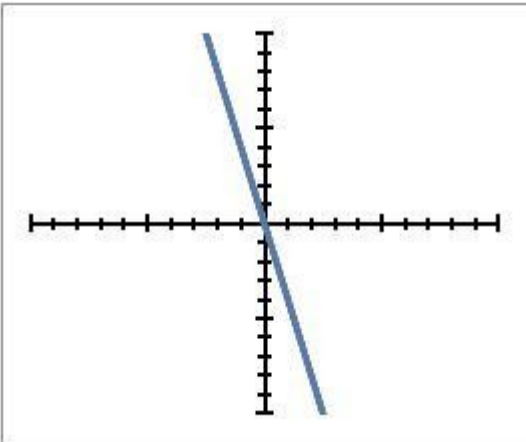

Both are Linear

Neither are Linear

A is Linear but B is not

B is Linear but A is not

57) Assistentment #64253 "64253 - 57752 - Recognizing Linear Functions"

Choose the answer that describes the two graphs shown below:

A)

B)

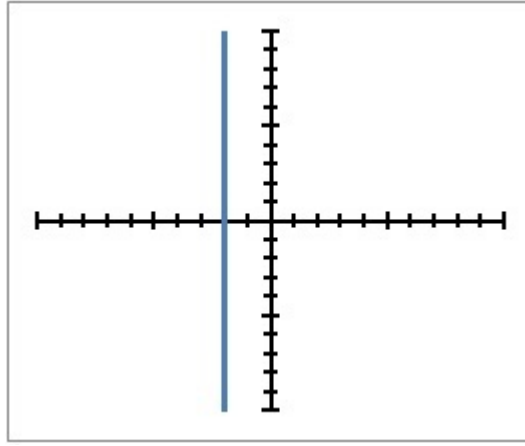
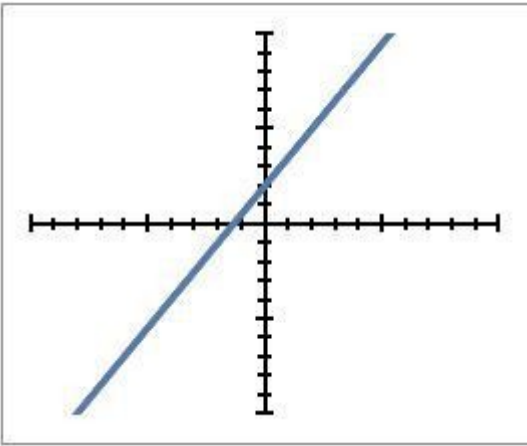

Both are Linear

Neither are Linear

A is Linear but B is not

B is Linear but A is not

58) Assisment #64254 "64254 - 57752 - Recognizing Linear Functions"

Choose the answer that describes the two graphs shown below:

A)

B)

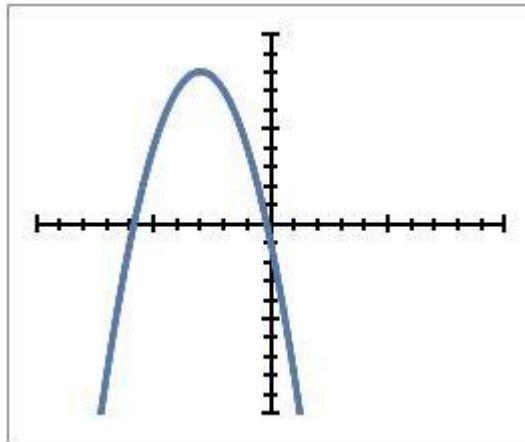
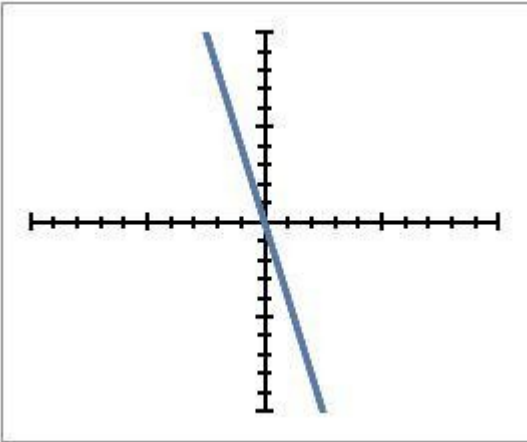

Both are Linear

Neither are Linear

A is Linear but B is not

B is Linear but A is not

59) Assisment #64255 "64255 - 57752 - Recognizing Linear Functions"

Choose the answer that describes the two graphs shown below:

A)

B)

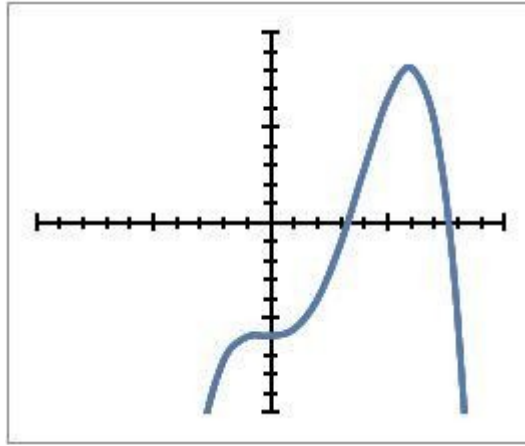
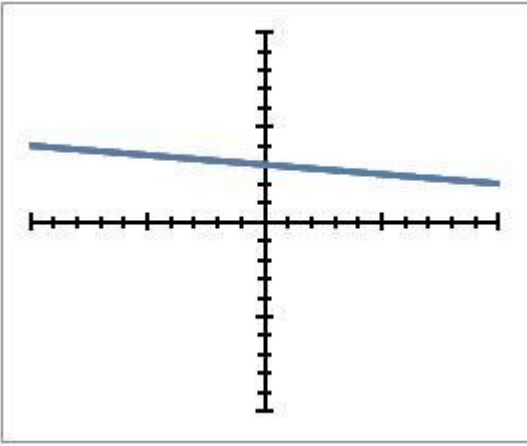

- Both are Linear
- Neither are Linear
- A is Linear but B is not
- B is Linear but A is not

60) Assistentment #64256 "64256 - 57752 - Recognizing Linear Functions"

Choose the answer that describes the two graphs shown below:

- A)**
- B)**

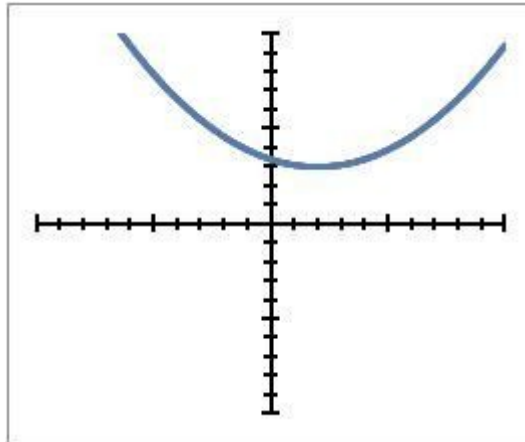
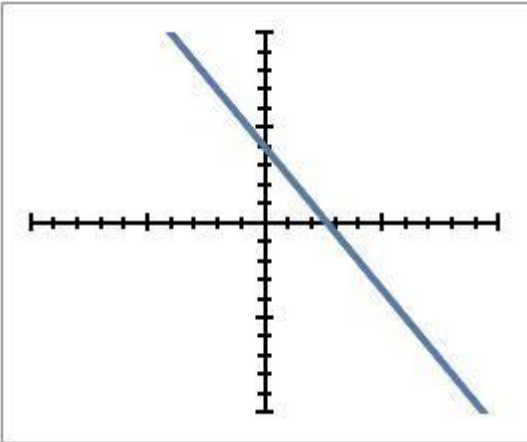

- Both are Linear
- Neither are Linear
- A is Linear but B is not
- B is Linear but A is not

61) Assistentment #64257 "64257 - 57852 - Recognizing Linear Functions"

Choose the answer that describes the two graphs shown below:

- A)**
- B)**

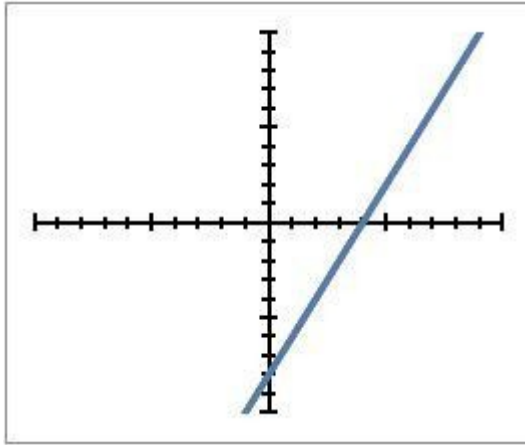
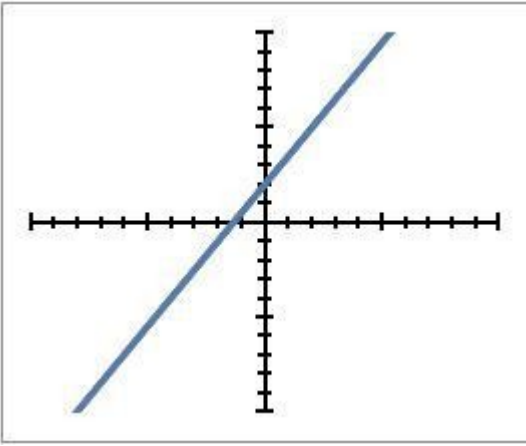

- Both are Linear
- Neither are Linear
- A is Linear but B is not
- B is Linear but A is not

62) Assisment #64258 "64258 - 57852 - Recognizing Linear Functions"

Choose the answer that describes the two graphs shown below:

A)

B)

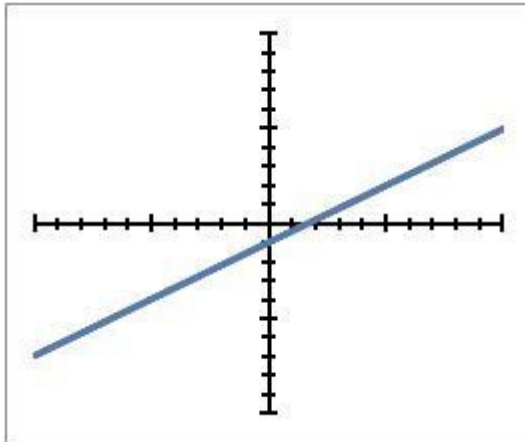
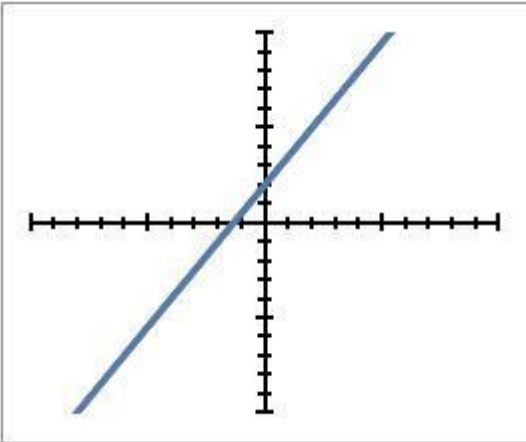

- Both are Linear
- Neither are Linear
- A is Linear but B is not
- B is Linear but A is not

63) Assisment #64259 "64259 - 57852 - Recognizing Linear Functions"

Choose the answer that describes the two graphs shown below:

A)

B)

Both are Linear

Neither are Linear

A is Linear but B is not

B is Linear but A is not

64) Assisment #64260 "64260 - 57852 - Recognizing Linear Functions"

Choose the answer that describes the two graphs shown below:

A)

B)

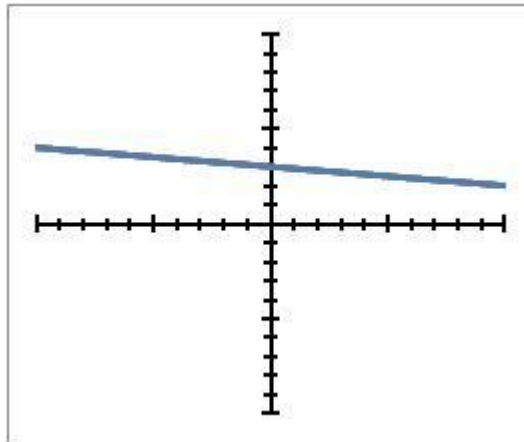
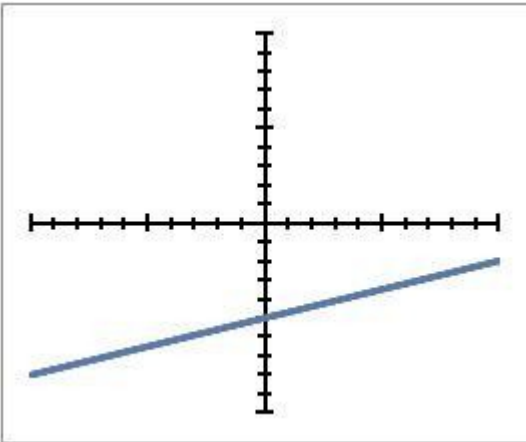

Both are Linear

Neither are Linear

A is Linear but B is not

B is Linear but A is not

65) Assisment #64261 "64261 - 57852 - Recognizing Linear Functions"

Choose the answer that describes the two graphs shown below:

A)

B)

Both are Linear

Neither are Linear

A is Linear but B is not

B is Linear but A is not

66) Assistent #64262 "64262 - 57852 - Recognizing Linear Functions"

Choose the answer that describes the two graphs shown below:

A)

B)

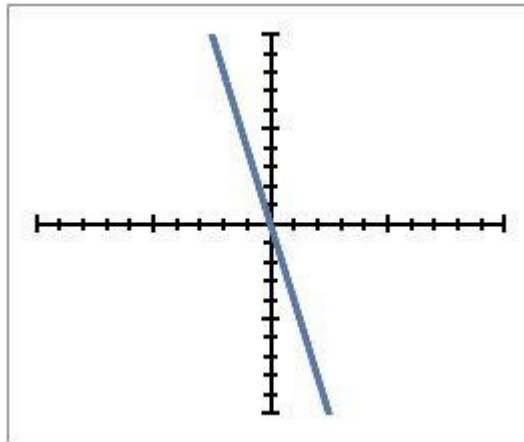
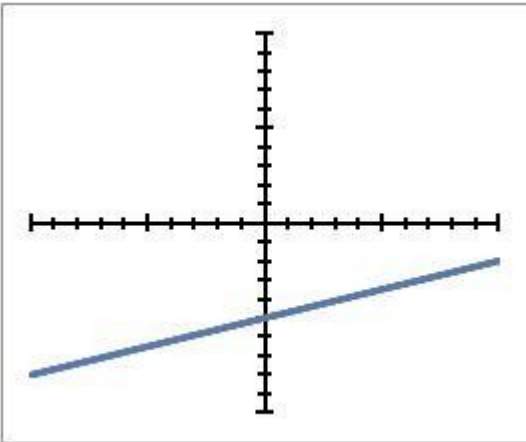

Both are Linear

Neither are Linear

A is Linear but B is not

B is Linear but A is not

67) Assistent #64263 "64263 - 57852 - Recognizing Linear Functions"

Choose the answer that describes the two graphs shown below:

A)

B)

Both are Linear

Neither are Linear

A is Linear but B is not

B is Linear but A is not

68) Assistentment #64264 "64264 - 57852 - Recognizing Linear Functions"

Choose the answer that describes the two graphs shown below:

A)

B)

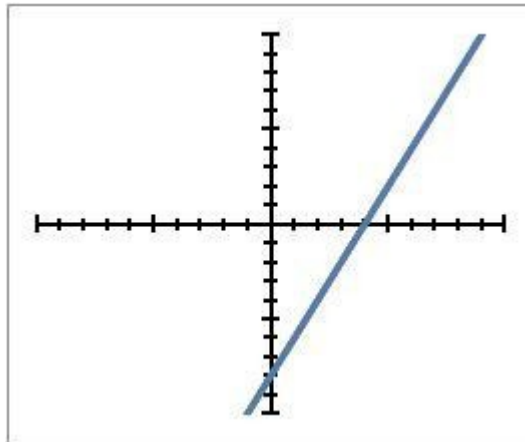
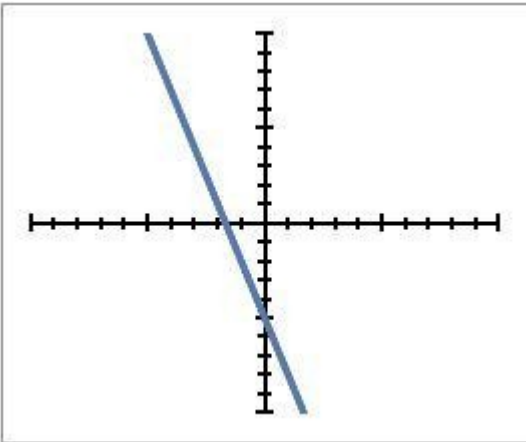

Both are Linear

Neither are Linear

A is Linear but B is not

B is Linear but A is not

69) Assistentment #64265 "64265 - 57852 - Recognizing Linear Functions"

Choose the answer that describes the two graphs shown below:

A)

B)

Both are Linear

Neither are Linear

A is Linear but B is not

B is Linear but A is not

70) Assistentment #64266 "64266 - 57852 - Recognizing Linear Functions"

Choose the answer that describes the two graphs shown below:

A)

B)

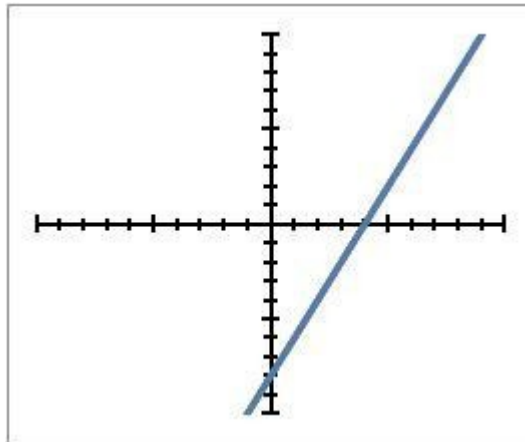
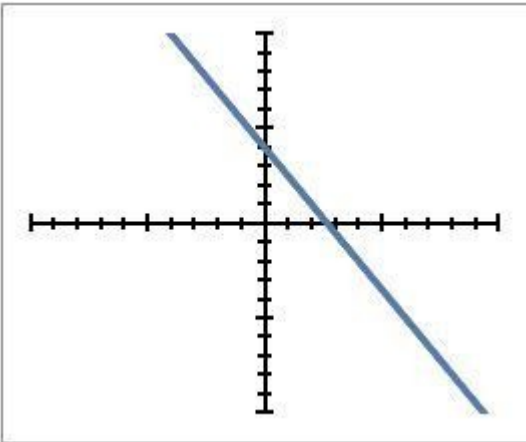

Both are Linear

Neither are Linear

A is Linear but B is not

B is Linear but A is not

71) Assistentment #64267 "64267 - 57852 - Recognizing Linear Functions"

Choose the answer that describes the two graphs shown below:

A)

B)

Both are Linear

Neither are Linear

A is Linear but B is not

B is Linear but A is not

72) Assisment #64268 "64268 - 57852 - Recognizing Linear Functions"

Choose the answer that describes the two graphs shown below:

A)

B)

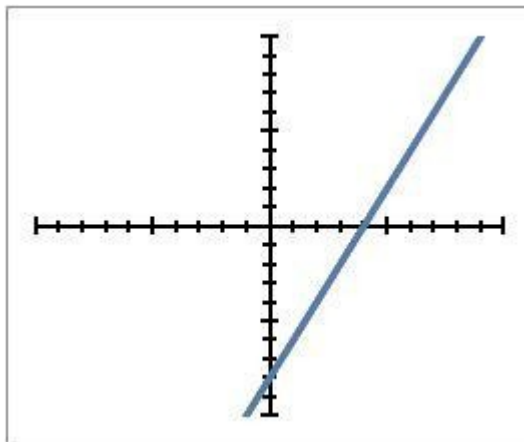
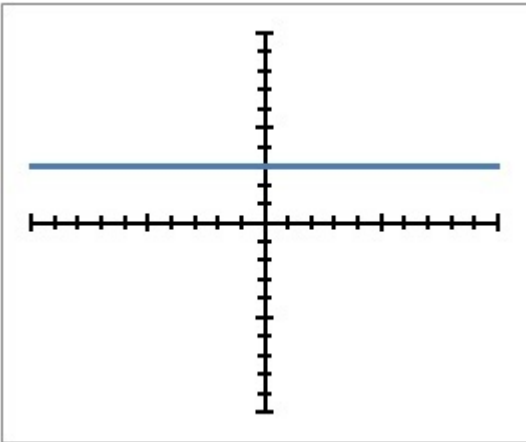

Both are Linear

Neither are Linear

A is Linear but B is not

B is Linear but A is not

73) Assisment #64269 "64269 - 57852 - Recognizing Linear Functions"

Choose the answer that describes the two graphs shown below:

A)

B)

Both are Linear

Neither are Linear

A is Linear but B is not

B is Linear but A is not

74) Assisment #64270 "64270 - 57852 - Recognizing Linear Functions"

Choose the answer that describes the two graphs shown below:

A)

B)

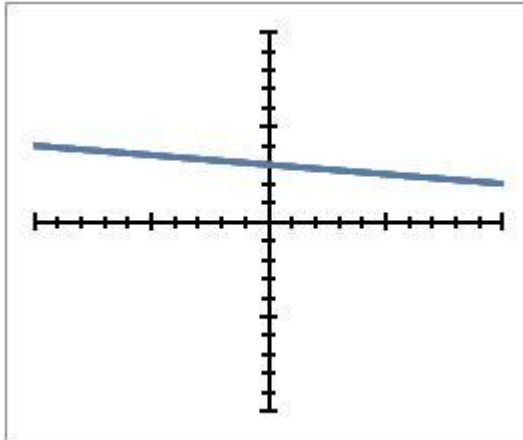
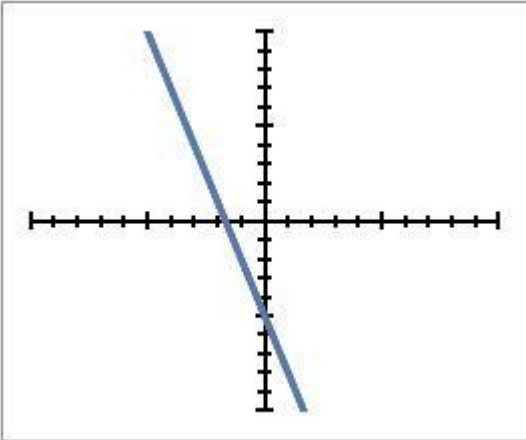

Both are Linear

Neither are Linear

A is Linear but B is not

B is Linear but A is not

75) Assisment #64271 "64271 - 57852 - Recognizing Linear Functions"

Choose the answer that describes the two graphs shown below:

A)

B)

Both are Linear

Neither are Linear

A is Linear but B is not

B is Linear but A is not

76) Assistentment #64272 "64272 - 57852 - Recognizing Linear Functions"

Choose the answer that describes the two graphs shown below:

A)

B)

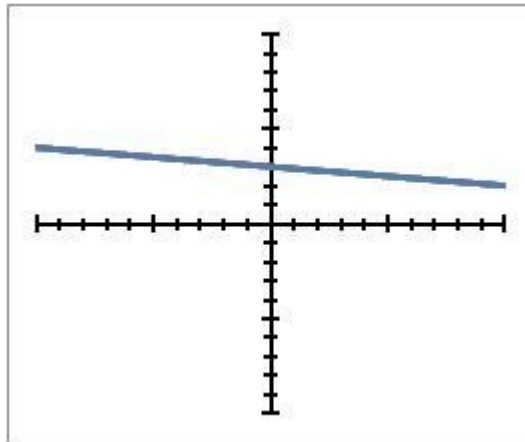
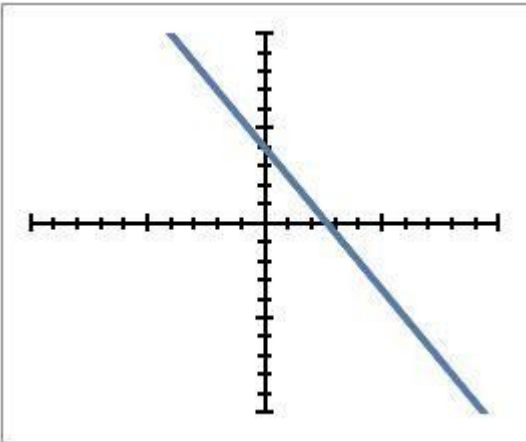

Both are Linear

Neither are Linear

A is Linear but B is not

B is Linear but A is not

77) Assistentment #64273 "64273 - 57852 - Recognizing Linear Functions"

Choose the answer that describes the two graphs shown below:

A)

B)

Both are Linear

Neither are Linear

A is Linear but B is not

B is Linear but A is not

78) Assistentment #64274 "64274 - 57852 - Recognizing Linear Functions"

Choose the answer that describes the two graphs shown below:

A)

B)

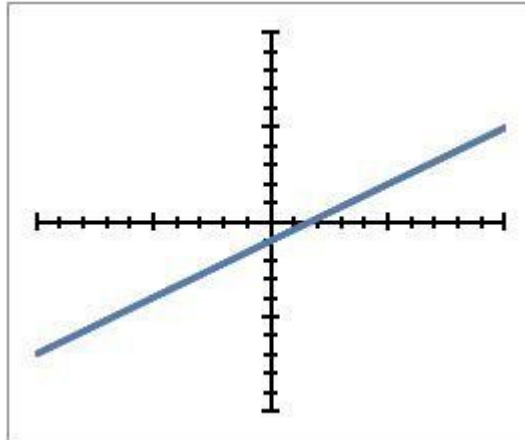
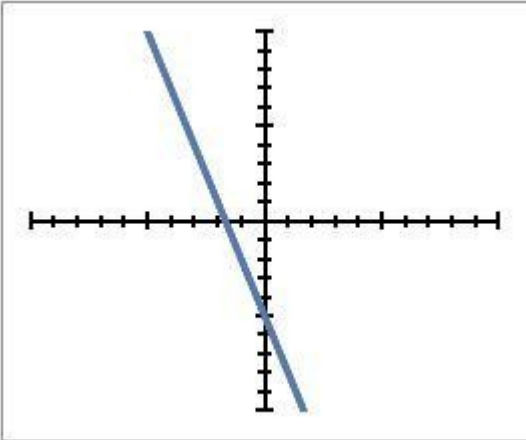

Both are Linear

Neither are Linear

A is Linear but B is not

B is Linear but A is not

79) Assistentment #64275 "64275 - 57852 - Recognizing Linear Functions"

Choose the answer that describes the two graphs shown below:

A)

B)

- Both are Linear
- Neither are Linear
- A is Linear but B is not
- B is Linear but A is not

80) Assisment #64276 "64276 - 57852 - Recognizing Linear Functions"

Choose the answer that describes the two graphs shown below:

A)

B)

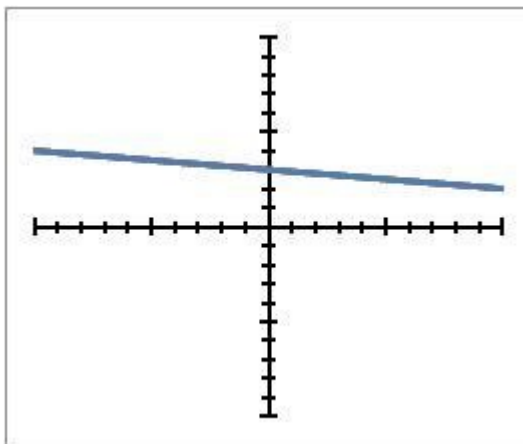
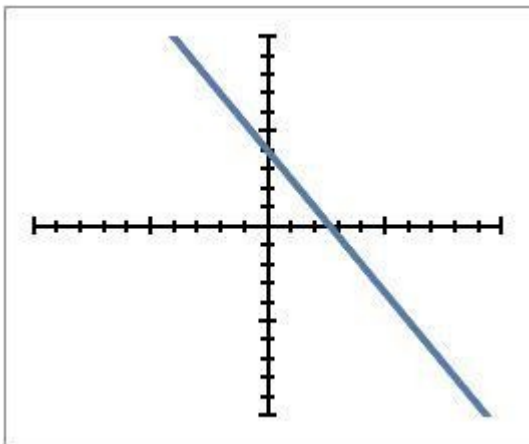

- Both are Linear
- Neither are Linear
- A is Linear but B is not
- B is Linear but A is not

Problem Set , +(%"Divisibility - THE SKILL BUILDING SET" id:[8741]

1) Assistent #63806 "63806 - 57322 - Divisibility by 2"

Which number is divisible by 2?

- 62
 - 31
 - 61
 - 131
 - 165
-

2) Assistent #63809 "63809 - 57322 - Divisibility by 2"

Which number is divisible by 2?

- 74
 - 37
 - 87
 - 139
 - 181
-

3) Assistent #63808 "63808 - 57322 - Divisibility by 2"

Which number is divisible by 2?

- 164
 - 45
 - 85
 - 121
 - 161
-

4) Assistent #63807 "63807 - 57322 - Divisibility by 2"

Which number is divisible by 2?

- 182
- 23
- 99
- 153
- 161

5) Assistent #63815 "63815 - 57322 - Divisibility by 2"

Which number is divisible by 2?

152

17

69

153

175

6) Assistent #63814 "63814 - 57322 - Divisibility by 2"

Which number is divisible by 2?

54

37

75

111

179

7) Assistent #63810 "63810 - 57322 - Divisibility by 2"

Which number is divisible by 2?

96

19

97

113

167

8) Assistent #63812 "63812 - 57322 - Divisibility by 2"

Which number is divisible by 2?

172

29

97

117

193

9) Assistent #63813 "63813 - 57322 - Divisibility by 2"

Which number is divisible by 2?

70

55

103

125

10) Assistent #63811 "63811 - 57322 - Divisibility by 2"

Which number is divisible by 2?

- 50
- 53
- 91
- 141
- 187

11) Assistent #63818 "63818 - 57331 - Divisibility by 3"

Which number is divisible by 3?

- 177
- 97
- 91
- 134
- 152

12) Assistent #63820 "63820 - 57331 - Divisibility by 3"

Which number is divisible by 3?

- 54
- 172
- 130
- 59
- 176

13) Assistent #63816 "63816 - 57331 - Divisibility by 3"

Which number is divisible by 3?

- 72
- 76
- 55
- 119
- 134

14) Assistent #63819 "63819 - 57331 - Divisibility by 3"

Which number is divisible by 3?

- 132
- 157
- 82

15) Assistent #63817 "63817 - 57331 - Divisibility by 3"

Which number is divisible by 3?

- 189
- 151
- 115
- 170
- 53

16) Assistent #63821 "63821 - 57331 - Divisibility by 3"

Which number is divisible by 3?

- 39
- 124
- 121
- 173
- 137

17) Assistent #63822 "63822 - 57331 - Divisibility by 3"

Which number is divisible by 3?

- 180
- 109
- 103
- 113
- 167

18) Assistent #63823 "63823 - 57331 - Divisibility by 3"

Which number is divisible by 3?

- 165
- 178
- 151
- 50
- 98

19) Assistent #63824 "63824 - 57331 - Divisibility by 3"

Which number is divisible by 3?

- 183
- 136

20) Assisment #63827 "63827 - 57616 - Divisibility by 4"

Which number is divisible by 4?

- 360
- 119
- 1089
- 342
- 1594

21) Assisment #63828 "63828 - 57616 - Divisibility by 4"

Which number is divisible by 4?

- 892
- 1311
- 285
- 886
- 1994

22) Assisment #63825 "63825 - 57331 - Divisibility by 3"

Which number is divisible by 3?

- 42
- 199
- 58
- 188
- 182

23) Assisment #63829 "63829 - 57616 - Divisibility by 4"

Which number is divisible by 4?

- 1596
- 1275
- 613
- 758
- 1114

24) Assisment #63830 "63830 - 57616 - Divisibility by 4"

Which number is divisible by 4?

- 512

25) Assistent #63826 "63826 - 57616 - Divisibility by 4"

Which number is divisible by 4?

- 104
- 711
- 841
- 710
- 1638

26) Assistent #63831 "63831 - 57616 - Divisibility by 4"

Which number is divisible by 4?

- 260
- 1887
- 217
- 518
- 1614

27) Assistent #63832 "63832 - 57616 - Divisibility by 4"

Which number is divisible by 4?

- 1616
- 139
- 261
- 962
- 1294

28) Assistent #63833 "63833 - 57616 - Divisibility by 4"

Which number is divisible by 4?

- 156
- 1187
- 845
- 438
- 1350

29) Assistent #63834 "63834 - 57616 - Divisibility by 4"

Which number is divisible by 4?

1840
1463
1029
186
1206

30) Assisment #63837 "63837 - 57618 - Divisibility by 5"

Which number is divisible by 5?

1400
891
353
736
29

31) Assisment #63836 "63836 - 57618 - Divisibility by 5"

Which number is divisible by 5?

775
161
1653
1757
1049

32) Assisment #63835 "63835 - 57616 - Divisibility by 4"

Which number is divisible by 4?

1112
655
141
222
1958

33) Assisment #63838 "63838 - 57618 - Divisibility by 5"

Which number is divisible by 5?

530
651
693
1296
258

34) Assisment #63839 "63839 - 57618 - Divisibility by 5"

Which number is divisible by 5?

- 1995
 - 1772
 - 663
 - 236
 - 1229
-

35) Assisment #63843 "63843 - 57618 - Divisibility by 5"

Which number is divisible by 5?

- 1095
 - 661
 - 1254
 - 287
 - 489
-

36) Assisment #63844 "63844 - 57618 - Divisibility by 5"

Which number is divisible by 5?

- 1010
 - 352
 - 843
 - 156
 - 1249
-

37) Assisment #63840 "63840 - 57618 - Divisibility by 5"

Which number is divisible by 5?

- 1900
 - 1792
 - 1343
 - 1556
 - 889
-

38) Assisment #63841 "63841 - 57618 - Divisibility by 5"

Which number is divisible by 5?

- 810
 - 372
 - 383
 - 97
 - 529
-

39) Assisment #63845 "63845 - 57618 - Divisibility by 5"

Which number is divisible by 5?

- 760
 - 1262
 - 1633
 - 1696
 - 789
-

40) Assisment #63842 "63842 - 57618 - Divisibility by 5"

Which number is divisible by 5?

- 310
 - 262
 - 1744
 - 1897
 - 839
-

41) Assisment #63846 "63846 - 57623 - Divisibility by 10"

Which number is divisible by 10?

- 1310
 - 1222
 - 764
 - 86
 - 289
-

42) Assisment #63851 "63851 - 57623 - Divisibility by 10"

Which number is divisible by 10?

- 60
 - 1861
 - 1453
 - 57
 - 1599
-

43) Assisment #63849 "63849 - 57623 - Divisibility by 10"

Which number is divisible by 10?

- 1620
- 1591
- 423
- 717
- 649

44) Assisment #63847 "63847 - 57623 - Divisibility by 10"

Which number is divisible by 10?

- 380
 - 1491
 - 1184
 - 1286
 - 1919
-

45) Assisment #63850 "63850 - 57623 - Divisibility by 10"

Which number is divisible by 10?

- 1300
 - 1682
 - 113
 - 506
 - 1119
-

46) Assisment #63848 "63848 - 57623 - Divisibility by 10"

Which number is divisible by 10?

- 1730
 - 511
 - 1033
 - 286
 - 989
-

47) Assisment #63856 "63856 - 57624 - Divisibility by 6"

Which number is divisible by 6?

- 186
 - 133
 - 122
 - 171
 - 166
-

48) Assisment #63854 "63854 - 57623 - Divisibility by 10"

Which number is divisible by 10?

- 1710
- 642
- 1624
- 457
- 1678

49) Assistent #63853 "63853 - 57623 - Divisibility by 10"

Which number is divisible by 10?

- 790
- 921
- 1673
- 756
- 1848

50) Assistent #63855 "63855 - 57623 - Divisibility by 10"

Which number is divisible by 10?

- 410
- 281
- 253
- 477
- 1749

51) Assistent #63857 "63857 - 57624 - Divisibility by 6"

Which number is divisible by 6?

- 114
- 193
- 164
- 45
- 178

52) Assistent #63859 "63859 - 57624 - Divisibility by 6"

Which number is divisible by 6?

- 48
- 85
- 62
- 189
- 190

53) Assistent #63858 "63858 - 57624 - Divisibility by 6"

Which number is divisible by 6?

- 120
- 115
- 140
- 153

54) Assistent #63860 "63860 - 57624 - Divisibility by 6"

Which number is divisible by 6?

- 36
- 49
- 182
- 195
- 40

55) Assistent #63861 "63861 - 57624 - Divisibility by 6"

Which number is divisible by 6?

- 162
- 133
- 164
- 69
- 82

56) Assistent #63852 "63852 - 57623 - Divisibility by 10"

Which number is divisible by 10?

- 40
- 1261
- 454
- 1667
- 1689

57) Assistent #63863 "63863 - 57624 - Divisibility by 6"

Which number is divisible by 6?

- 36
- 73
- 92
- 135
- 58

58) Assistent #63862 "63862 - 57624 - Divisibility by 6"

Which number is divisible by 6?

- 150
- 151
- 68

59) Assistent #63864 "63864 - 57624 - Divisibility by 6"

Which number is divisible by 6?

- 90
- 115
- 98
- 141
- 148

60) Assistent #63865 "63865 - 57624 - Divisibility by 6"

Which number is divisible by 6?

- 174
- 193
- 110
- 183
- 142

61) Assistent #63866 "63866 - 62274 - Divisibility by 9"

Which number is divisible by 9?

- 189
- 76
- 55
- 119
- 134
- 183

62) Assistent #63867 "63867 - 62274 - Divisibility by 9"

Which number is divisible by 9?

- 162
- 151
- 115
- 170
- 53
- 129

63) Assistent #63870 "63870 - 62274 - Divisibility by 9"

Which number is divisible by 9?

59
176
102

64) Assistent #63871 "63871 - 62274 - Divisibility by 9"

Which number is divisible by 9?

63
124
121
173
137
75

65) Assistent #63872 "63872 - 62274 - Divisibility by 9"

Which number is divisible by 9?

81
109
103
113
167
84

66) Assistent #63873 "63873 - 62274 - Divisibility by 9"

Which number is divisible by 9?

54
178
151
50
98
156

67) Assistent #63874 "63874 - 62274 - Divisibility by 9"

Which number is divisible by 9?

36
136
97

68) Assistent #63875 "63875 - 62274 - Divisibility by 9"

Which number is divisible by 9?

144

199

58

188

182

66

69) Assistent #63869 "63869 - 62274 - Divisibility by 9"

Which number is divisible by 9?

198

157

82

116

83

129

70) Assistent #63868 "63868 - 62274 - Divisibility by 9"

Which number is divisible by 9?

63

97

91

134

152

174

1) Assistent #109711 "109711 - 7c"

If the following two expressions are equivalent or not:

1. $10x + (-42) + (-31x)$
2. $-21x + (-42)$

Yes, the two expressions are equivalent

No, the two expressions are not equivalent

2) Assistent #109712 "109712 - 7c"

If the following two expressions are equivalent or not:

1. $12x + (-12) + 31x$
2. $43x + (-12)$

Yes, the two expressions are equivalent

No, the two expressions are not equivalent

3) Assistent #109713 "109713 - 7c"

If the following two expressions are equivalent or not:

1. $(-8x) + (-24) + (-36x)$
2. $-44x + (-24)$

Yes, the two expressions are equivalent

No, the two expressions are not equivalent

4) Assistent #109714 "109714 - 7c"

If the following two expressions are equivalent or not:

1. $(-9x) + (-3) + 21x$
2. $12x + (-3)$

Yes, the two expressions are equivalent

No, the two expressions are not equivalent

5) Assistent #109715 "109715 - 7c"

If the following two expressions are equivalent or not:

1. $11x + 39 + 41x$
2. $52x + 39$

Yes, the two expressions are equivalent

No, the two expressions are not equivalent

6) Assistent #109716 "109716 - 7c"

If the following two expressions are equivalent or not:

1. $(-3x) + 33 + (-26x)$
2. $-29x + 33$

Yes, the two expressions are equivalent

No, the two expressions are not equivalent

7) Assistent #109717 "109717 - 7c"

If the following two expressions are equivalent or not:

1. $10x + 12 + (-30x)$
2. $-20x + 12$

Yes, the two expressions are equivalent

No, the two expressions are not equivalent

8) Assistent #109718 "109718 - 7c"

If the following two expressions are equivalent or not:

1. $10x + (-41) + 19x$
2. $29x + (-41)$

Yes, the two expressions are equivalent

No, the two expressions are not equivalent

9) Assistent #109719 "109719 - 7c"

If the following two expressions are equivalent or not:

1. $12x + (-32) + (-26x)$
2. $-14x + (-32)$

Yes, the two expressions are equivalent

No, the two expressions are not equivalent

10) Assistent #109720 "109720 - 7c"

If the following two expressions are equivalent or not:

1. $9x + 11 + (-8x)$
2. $1x + 11$

Yes, the two expressions are equivalent

No, the two expressions are not equivalent

11) Assistent #109721 "109721 - 7c"

If the following two expressions are equivalent or not:

1. $3x + (-28) + 27x$
2. $30x + (-28)$

Yes, the two expressions are equivalent

No, the two expressions are not equivalent

12) Assistent #109722 "109722 - 7c"

If the following two expressions are equivalent or not:

1. $(-16x) + 43 + (-4x)$
2. $-20x + 43$

Yes, the two expressions are equivalent

No, the two expressions are not equivalent

13) Assistent #109723 "109723 - 7c"

If the following two expressions are equivalent or not:

1. $(-14x) + 59 + 32x$
2. $18x + 59$

Yes, the two expressions are equivalent

No, the two expressions are not equivalent

14) Assistent #109724 "109724 - 7c"

If the following two expressions are equivalent or not:

1. $(-10x) + 59 + 45x$
2. $35x + 59$

Yes, the two expressions are equivalent

No, the two expressions are not equivalent

15) Assisment #109725 "109725 - 7c"

If the following two expressions are equivalent or not:

1. $(-4x) + 36 + 44x$
2. $40x + 36$

Yes, the two expressions are equivalent

No, the two expressions are not equivalent

16) Assisment #109726 "109726 - 7c"

If the following two expressions are equivalent or not:

1. $(-10x) + (-34) + (-18x)$
2. $-28x + (-34)$

Yes, the two expressions are equivalent

No, the two expressions are not equivalent

17) Assisment #109727 "109727 - 7c"

If the following two expressions are equivalent or not:

1. $(-5x) + (-18) + 5x$
2. $0x + (-18)$

Yes, the two expressions are equivalent

No, the two expressions are not equivalent

18) Assisment #109728 "109728 - 7c"

Are the following expressions equivalent or not?

1. $(-10x) + (-1) + 25x$
2. $15x + (-1)$

Yes, the two expressions are equivalent

No, the two expressions are not equivalent

If the following two expressions are equivalent or not:

1. $(-16x) + 19 + (-35x)$
2. $-51x + 19$

Yes, the two expressions are equivalent

No, the two expressions are not equivalent

20) Assistent #109730 "109730 - 7c"

If the following two expressions are equivalent or not:

1. $(-1x) + 24 + (-50x)$
2. $-51x + 24$

Yes, the two expressions are equivalent

No, the two expressions are not equivalent

21) Assistent #109731 "109731 - 9c"

Are the following two expressions equivalent?

1. $(-9x + 50) + (-21x - 23)$
2. $-30x + 27$

Yes, they are equivalent.

No, they are not equivalent.

22) Assistent #109732 "109732 - 9c"

Are the following two expressions equivalent?

1. $(-24x + 58) + (29x - 29)$
2. $5x + 29$

Yes, they are equivalent.

No, they are not equivalent.

23) Assistent #109733 "109733 - 9c"

Are the following two expressions equivalent?

1. $(-17x + 38) + (-31x - 25)$
2. $-48x + 13$

Yes, they are equivalent.

No, they are not equivalent.

Are the following two expressions equivalent?

1. $(-2x + 48) + (-28x - 21)$
2. $-30x + 27$

Yes, they are equivalent.

No, they are not equivalent.

25) Assisment #109735 "109735 - 9c"

Are the following two expressions equivalent?

1. $(-15x + 11) + (-15x - 4)$
2. $-30x + 7$

Yes, they are equivalent.

No, they are not equivalent.

26) Assisment #109736 "109736 - 9c"

Are the following two expressions equivalent?

1. $(-13x + 38) + (13x - 27)$
2. $0x + 11$

Yes, they are equivalent.

No, they are not equivalent.

27) Assisment #109737 "109737 - 9c"

Are the following two expressions equivalent?

1. $(41x + 21) + (-21x - 19)$
2. $20x + 2$

Yes, they are equivalent.

No, they are not equivalent.

28) Assisment #109738 "109738 - 9c"

Are the following two expressions equivalent?

1. $(16x + 40) + (22x - 16)$
2. $38x + 24$

Yes, they are equivalent.

No, they are not equivalent.

29) Assisment #109739 "109739 - 9c"

Are the following two expressions equivalent?

1. $(5x + 27) + (28x - 9)$
2. $33x + 18$

Yes, they are equivalent.

No, they are not equivalent.

30) Assisment #109740 "109740 - 9c"

Are the following two expressions equivalent?

1. $(16x + 37) + (-19x - 14)$
2. $-3x + 23$

Yes, they are equivalent.

No, they are not equivalent.

31) Assisment #109741 "109741 - 9c"

Are the following two expressions equivalent?

1. $(14x + 33) + (12x - 20)$
2. $26x + 13$

Yes, they are equivalent.

No, they are not equivalent.

32) Assisment #109742 "109742 - 9c"

Are the following two expressions equivalent?

1. $(8x + 22) + (13x - 6)$
2. $21x + 16$

Yes, they are equivalent.

No, they are not equivalent.

33) Assisment #109743 "109743 - 9c"

Are the following two expressions equivalent?

1. $(39x + 40) + (22x - 12)$
2. $61x + 28$

Yes, they are equivalent.

No, they are not equivalent.

34) Assisment #109744 "109744 - 9c"

Are the following two expressions equivalent?

1. $(-37x + 13) + (-2x - 11)$
2. $-39x + 2$

Yes, they are equivalent.

No, they are not equivalent.

35) Assisment #109745 "109745 - 9c"

Are the following two expressions equivalent?

1. $(-44x + 34) + (19x - 3)$
2. $-25x + 31$

Yes, they are equivalent.

No, they are not equivalent.

36) Assisment #109746 "109746 - 9c"

Are the following two expressions equivalent?

1. $(-5x + 24) + (-18x - 9)$
2. $-23x + 15$

Yes, they are equivalent.

No, they are not equivalent.

37) Assisment #109747 "109747 - 9c"

Are the following two expressions equivalent?

1. $(-8x + 32) + (-25x - 12)$
2. $-33x + 20$

Yes, they are equivalent.

No, they are not equivalent.

38) Assisment #109748 "109748 - 9c"

Are the following two expressions equivalent?

1. $(-45x + 35) + (1x - 19)$
2. $-44x + 16$

Yes, they are equivalent.

No, they are not equivalent.

39) Assisment #109749 "109749 - 9c"

Are the following two expressions equivalent?

1. $(-16x + 21) + (-22x - 5)$
2. $-38x + 16$

Yes, they are equivalent.

No, they are not equivalent.

40) Assisment #109750 "109750 - 9c"

Are the following two expressions equivalent?

1. $(-16x + 36) + (-27x - 13)$
2. $-43x + 23$

Yes, they are equivalent.

No, they are not equivalent.

41) Assisment #109751 "109751 - 2 Dist, 1 Comm, Y"

If the following two expressions are equivalent or not:

1. $-5(11x + 6) + (-2) + (-42x)$
2. $-97x + (-32)$

Yes, the two expressions are equivalent

No, the two expressions are not equivalent

42) Assisment #109752 "109752 - 2 Dist, 1 Comm, Y"

If the following two expressions are equivalent or not:

1. $4(2x + 6) + 20 + (-49x)$
2. $-41x + 44$

Yes, the two expressions are equivalent

No, the two expressions are not equivalent

43) Assisment #109753 "109753 - 2 Dist, 1 Comm, Y"

If the following two expressions are equivalent or not:

1. $3(2x + 8) + 22 + (-3x)$
2. $3x + 46$

Yes, the two expressions are equivalent

No, the two expressions are not equivalent

44) Assisment #109754 "109754 - 2 Dist, 1 Comm, Y"

If the following two expressions are equivalent or not:

1. $-4(7x + 5) + (-44) + (-23x)$
2. $-51x + (-64)$

Yes, the two expressions are equivalent

No, the two expressions are not equivalent

45) Assisment #109755 "109755 - 2 Dist, 1 Comm, Y"

If the following two expressions are equivalent or not:

1. $1(4x + 3) + 54 + 35x$
2. $39x + 57$

Yes, the two expressions are equivalent

No, the two expressions are not equivalent

46) Assisment #109756 "109756 - 2 Dist, 1 Comm, Y"

If the following two expressions are equivalent or not:

1. $-4(5x + 1) + (-53) + 1x$
2. $-19x + (-57)$

Yes, the two expressions are equivalent

No, the two expressions are not equivalent

47) Assisment #109757 "109757 - 2 Dist, 1 Comm, Y"

If the following two expressions are equivalent or not:

1. $5(11x + 6) + 55 + 28x$
2. $83x + 85$

Yes, the two expressions are equivalent

No, the two expressions are not equivalent

48) Assisment #109758 "109758 - 2 Dist, 1 Comm, Y"

If the following two expressions are equivalent or not:

1. $6(3x + 2) + 43 + (-48x)$
2. $-30x + 55$

Yes, the two expressions are equivalent

No, the two expressions are not equivalent

49) Assisment #109759 "109759 - 2 Dist, 1 Comm, Y"

If the following two expressions are equivalent or not:

1. $5(6x + 11) + 8 + (-11x)$
2. $19x + 63$

Yes, the two expressions are equivalent

No, the two expressions are not equivalent

50) Assisment #109760 "109760 - 2 Dist, 1 Comm, Y"

If the following two expressions are equivalent or not:

1. $4(11x + 5) + 26 + 26x$
2. $70x + 46$

Yes, the two expressions are equivalent

No, the two expressions are not equivalent

51) Assisment #109761 "109761 - 2 Dist, 1 Comm, Y"

If the following two expressions are equivalent or not:

1. $-1(5x + 9) + (-57) + (-29x)$
2. $-34x + (-66)$

Yes, the two expressions are equivalent

No, the two expressions are not equivalent

52) Assisment #109762 "109762 - 2 Dist, 1 Comm, Y"

If the following two expressions are equivalent or not:

1. $6(6x + 2) + 8 + (-36x)$
2. $0x + 20$

Yes, the two expressions are equivalent

No, the two expressions are not equivalent

53) Assisment #109763 "109763 - 2 Dist, 1 Comm, Y"

If the following two expressions are equivalent or not:

1. $-6(6x + 10) + (-1) + 43x$
2. $7x + (-61)$

Yes, the two expressions are equivalent

No, the two expressions are not equivalent

54) Assisment #109764 "109764 - 2 Dist, 1 Comm, Y"

If the following two expressions are equivalent or not:

1. $6(6x + 4) + 57 + (-28x)$
2. $8x + 81$

Yes, the two expressions are equivalent

No, the two expressions are not equivalent

55) Assisment #109765 "109765 - 2 Dist, 1 Comm, Y"

If the following two expressions are equivalent or not:

1. $-6(7x + 1) + (-25) + 15x$
2. $-27x + (-31)$

Yes, the two expressions are equivalent

No, the two expressions are not equivalent

56) Assisment #109766 "109766 - 2 Dist, 1 Comm, Y"

If the following two expressions are equivalent or not:

1. $-4(5x + 4) + (-23) + 5x$
2. $-15x + (-39)$

Yes, the two expressions are equivalent

No, the two expressions are not equivalent

57) Assisment #109767 "109767 - 2 Dist, 1 Comm, Y"

If the following two expressions are equivalent or not:

1. $2(3x + 8) + 21 + 39x$
2. $45x + 37$

Yes, the two expressions are equivalent

No, the two expressions are not equivalent

58) Assisment #109768 "109768 - 2 Dist, 1 Comm, Y"

If the following two expressions are equivalent or not:

1. $1(4x + 10) + 33 + (-40x)$
2. $-36x + 43$

Yes, the two expressions are equivalent

No, the two expressions are not equivalent

59) Assisment #109769 "109769 - 2 Dist, 1 Comm, Y"

If the following two expressions are equivalent or not:

1. $1(6x + 9) + 42 + (-8x)$
2. $-2x + 51$

Yes, the two expressions are equivalent

No, the two expressions are not equivalent

60) Assisment #109770 "109770 - 2 Dist, 1 Comm, Y"

If the following two expressions are equivalent or not:

1. $6(10x + 2) + 14 + 23x$
2. $83x + 26$

Yes, the two expressions are equivalent

No, the two expressions are not equivalent

61) Assisment #109771 "109771 - 7c"

If the following two expressions are equivalent or not:

1. $(-8x) + (-33) + (-29x)$
2. $-35x + (-33)$

Yes, the two expressions are equivalent

No, the two expressions are not equivalent

62) Assisment #109772 "109772 - 7c"

If the following two expressions are equivalent or not:

1. $(-2x) + (-30) + 13x$
2. $14x + (-30)$

Yes, the two expressions are equivalent

No, the two expressions are not equivalent

63) Assisment #109773 "109773 - 7c"

If the following two expressions are equivalent or not:

1. $2x + (-43) + 13x$
2. $14x + (-43)$

Yes, the two expressions are equivalent

No, the two expressions are not equivalent

64) Assisment #109774 "109774 - 7c"

If the following two expressions are equivalent or not:

1. $(-10x) + (-11) + (-48x)$
2. $-56x + (-11)$

Yes, the two expressions are equivalent

No, the two expressions are not equivalent

65) Assisment #109775 "109775 - 7c"

If the following two expressions are equivalent or not:

1. $(-9x) + 10 + 18x$
2. $11x + 10$

Yes, the two expressions are equivalent

No, the two expressions are not equivalent

66) Assisment #109776 "109776 - 7c"

If the following two expressions are equivalent or not:

1. $(-10x) + 34 + (-4x)$
2. $-12x + 34$

Yes, the two expressions are equivalent

No, the two expressions are not equivalent

67) Assistent #109777 "109777 - 7c"

If the following two expressions are equivalent or not:

1. $(-4x) + 24 + (-30x)$
2. $-31x + 24$

Yes, the two expressions are equivalent

No, the two expressions are not equivalent

68) Assistent #109778 "109778 - 7c"

If the following two expressions are equivalent or not:

1. $(-8x) + (-8) + 49x$
2. $44x + (-8)$

Yes, the two expressions are equivalent

No, the two expressions are not equivalent

69) Assistent #109779 "109779 - 7c"

If the following two expressions are equivalent or not:

1. $(-4x) + (-54) + 9x$
2. $8x + (-54)$

Yes, the two expressions are equivalent

No, the two expressions are not equivalent

70) Assistent #109780 "109780 - 7c"

If the following two expressions are equivalent or not:

1. $15x + 32 + 7x$
2. $20x + 32$

Yes, the two expressions are equivalent

No, the two expressions are not equivalent

71) Assistent #109781 "109781 - 7c"

If the following two expressions are equivalent or not:

1. $(-16x) + (-49) + 5x$
2. $-8x + (-49)$

Yes, the two expressions are equivalent

No, the two expressions are not equivalent

72) Assistent #109782 "109782 - 7c"

If the following two expressions are equivalent or not:

1. $15x + 26 + 34x$
2. $48x + 26$

Yes, the two expressions are equivalent

No, the two expressions are not equivalent

73) Assistent #109783 "109783 - 7c"

If the following two expressions are equivalent or not:

1. $8x + (-4) + (-47x)$
2. $-42x + (-4)$

Yes, the two expressions are equivalent

No, the two expressions are not equivalent

74) Assistent #109784 "109784 - 7c"

If the following two expressions are equivalent or not:

1. $8x + 52 + 35x$
2. $41x + 52$

Yes, the two expressions are equivalent

No, the two expressions are not equivalent

75) Assistent #109785 "109785 - 7c"

If the following two expressions are equivalent or not:

1. $7x + 13 + 26x$
2. $32x + 13$

Yes, the two expressions are equivalent

No, the two expressions are not equivalent

76) Assistent #109786 "109786 - 7c"

If the following two expressions are equivalent or not:

1. $7x + 1 + (-31x)$
2. $-25x + 1$

Yes, the two expressions are equivalent

No, the two expressions are not equivalent

77) Assistent #109787 "109787 - 7c"

If the following two expressions are equivalent or not:

1. $9x + 53 + 11x$
2. $18x + 53$

Yes, the two expressions are equivalent

No, the two expressions are not equivalent

78) Assistent #109788 "109788 - 7c"

If the following two expressions are equivalent or not:

1. $7x + (-61) + (-42x)$
2. $-37x + (-61)$

Yes, the two expressions are equivalent

No, the two expressions are not equivalent

79) Assistent #109789 "109789 - 7c"

If the following two expressions are equivalent or not:

1. $15x + 3 + 37x$
2. $51x + 3$

Yes, the two expressions are equivalent

No, the two expressions are not equivalent

80) Assistent #109790 "109790 - 7c"

If the following two expressions are equivalent or not:

1. $5x + 18 + 46x$
2. $49x + 18$

Yes, the two expressions are equivalent

No, the two expressions are not equivalent

81) Assistent #109791 "109791 - 9c"

Are the following two expressions equivalent?

1. $(4x + 4) + (28x - 2)$
2. $32x + 1$

Yes, they are equivalent.

No, they are not equivalent.

82) Assisment #109792 "109792 - 9c"

Are the following two expressions equivalent?

1. $(13x + 14) + (-10x - 1)$
2. $3x + 11$

Yes, they are equivalent.

No, they are not equivalent.

83) Assisment #109793 "109793 - 9c"

Are the following two expressions equivalent?

1. $(14x + 20) + (-13x - 5)$
2. $1x + 12$

Yes, they are equivalent.

No, they are not equivalent.

84) Assisment #109794 "109794 - 9c"

Are the following two expressions equivalent?

1. $(40x + 20) + (-19x - 11)$
2. $21x + 0$

Yes, they are equivalent.

No, they are not equivalent.

85) Assisment #109795 "109795 - 9c"

Are the following two expressions equivalent?

1. $(-11x + 37) + (-3x - 7)$
2. $-14x + 39$

Yes, they are equivalent.

No, they are not equivalent.

86) Assisment #109796 "109796 - 9c"

Are the following two expressions equivalent?

1. $(44x + 15) + (-8x - 7)$
2. $36x + 0$

Yes, they are equivalent.

No, they are not equivalent.

87) Assisment #109797 "109797 - 9c"

Are the following two expressions equivalent?

1. $(-50x + 35) + (-26x - 16)$
2. $-76x + 20$

Yes, they are equivalent.

No, they are not equivalent.

88) Assisment #109798 "109798 - 9c"

Are the following two expressions equivalent?

1. $(37x + 7) + (17x - 6)$
2. $54x + -10$

Yes, they are equivalent.

No, they are not equivalent.

89) Assisment #109799 "109799 - 9c"

Are the following two expressions equivalent?

1. $(-51x + 16) + (23x - 12)$
2. $-28x + 13$

Yes, they are equivalent.

No, they are not equivalent.

90) Assisment #109800 "109800 - 9c"

Are the following two expressions equivalent?

1. $(-21x + 35) + (-5x - 4)$
2. $-26x + 38$

Yes, they are equivalent.

No, they are not equivalent.

91) Assisment #109801 "109801 - 9c"

Are the following two expressions equivalent?

1. $(42x + 25) + (18x - 8)$
2. $60x + 13$

Yes, they are equivalent.

No, they are not equivalent.

92) Assisment #109802 "109802 - 9c"

Are the following two expressions equivalent?

1. $(-34x + 27) + (29x - 3)$
2. $-5x + 25$

Yes, they are equivalent.

No, they are not equivalent.

93) Assisment #109803 "109803 - 9c"

Are the following two expressions equivalent?

1. $(-1x + 29) + (-19x - 3)$
2. $-20x + 34$

Yes, they are equivalent.

No, they are not equivalent.

94) Assisment #109804 "109804 - 9c"

Are the following two expressions equivalent?

1. $(47x + 24) + (-6x - 5)$
2. $41x + 11$

Yes, they are equivalent.

No, they are not equivalent.

95) Assisment #109805 "109805 - 9c"

Are the following two expressions equivalent?

1. $(-49x + 39) + (-18x - 15)$
2. $-67x + 27$

Yes, they are equivalent.

No, they are not equivalent.

96) Assisment #109806 "109806 - 9c"

Are the following two expressions equivalent?

1. $(18x + 35) + (2x - 13)$
2. $20x + 21$

Yes, they are equivalent.

No, they are not equivalent.

97) Assisment #109807 "109807 - 9c"

Are the following two expressions equivalent?

1. $(31x + 28) + (-26x - 2)$
2. $5x + 20$

Yes, they are equivalent.

No, they are not equivalent.

98) Assisment #109808 "109808 - 9c"

Are the following two expressions equivalent?

1. $(-28x + 6) + (-25x - 3)$
2. $-53x + 4$

Yes, they are equivalent.

No, they are not equivalent.

99) Assisment #109809 "109809 - 9c"

Are the following two expressions equivalent?

1. $(18x + 32) + (-9x - 5)$
2. $9x + 22$

Yes, they are equivalent.

No, they are not equivalent.

100) Assisment #109810 "109810 - 9c"

Are the following two expressions equivalent?

1. $(-27x + 17) + (-26x - 6)$
2. $-53x + 15$

Yes, they are equivalent.

No, they are not equivalent.

101) Assisment #109811 "109811 - 2 Dist, 1 Comm, Y"

If the following two expressions are equivalent or not:

1. $-4(10x + 7) + (-37) + (-2x)$
2. $-41x + (-65)$

Yes, the two expressions are equivalent

No, the two expressions are not equivalent

102) Assisment #109812 "109812 - 2 Dist, 1 Comm, Y"

If the following two expressions are equivalent or not:

1. $3(6x + 1) + 42 + (-2x)$
2. $13x + 45$

Yes, the two expressions are equivalent

No, the two expressions are not equivalent

103) Assistent #109813 "109813 - 2 Dist, 1 Comm, Y"

If the following two expressions are equivalent or not:

1. $6(6x + 1) + 10 + (-3x)$
2. $28x + 16$

Yes, the two expressions are equivalent

No, the two expressions are not equivalent

104) Assistent #109814 "109814 - 2 Dist, 1 Comm, Y"

If the following two expressions are equivalent or not:

1. $6(7x + 3) + 7 + (-32x)$
2. $5x + 25$

Yes, the two expressions are equivalent

No, the two expressions are not equivalent

105) Assistent #109815 "109815 - 2 Dist, 1 Comm, Y"

If the following two expressions are equivalent or not:

1. $5(7x + 9) + 20 + 51x$
2. $84x + 65$

Yes, the two expressions are equivalent

No, the two expressions are not equivalent

106) Assistent #109816 "109816 - 2 Dist, 1 Comm, Y"

If the following two expressions are equivalent or not:

1. $-1(11x + 4) + (-59) + 4x$
2. $-5x + (-63)$

Yes, the two expressions are equivalent

No, the two expressions are not equivalent

107) Assistent #109817 "109817 - 2 Dist, 1 Comm, Y"

If the following two expressions are equivalent or not:

1. $5(2x + 2) + 43 + (-16x)$
2. $-11x + 53$

Yes, the two expressions are equivalent

No, the two expressions are not equivalent

108) Assistent #109818 "109818 - 2 Dist, 1 Comm, Y"

If the following two expressions are equivalent or not:

1. $-4(10x + 9) + (-24) + 12x$
2. $-23x + (-60)$

Yes, the two expressions are equivalent

No, the two expressions are not equivalent

109) Assistent #109819 "109819 - 2 Dist, 1 Comm, Y"

If the following two expressions are equivalent or not:

1. $-6(10x + 4) + (-28) + (-15x)$
2. $-72x + (-52)$

Yes, the two expressions are equivalent

No, the two expressions are not equivalent

110) Assistent #109820 "109820 - 2 Dist, 1 Comm, Y"

If the following two expressions are equivalent or not:

1. $3(4x + 8) + 9 + 45x$
2. $54x + 33$

Yes, the two expressions are equivalent

No, the two expressions are not equivalent

111) Assistent #109821 "109821 - 2 Dist, 1 Comm, Y"

If the following two expressions are equivalent or not:

1. $1(6x + 9) + 56 + (-28x)$
2. $-23x + 65$

Yes, the two expressions are equivalent

No, the two expressions are not equivalent

112) Assistent #109822 "109822 - 2 Dist, 1 Comm, Y"

If the following two expressions are equivalent or not:

1. $-1(4x + 7) + (-60) + (-37x)$
2. $-38x + (-67)$

Yes, the two expressions are equivalent

No, the two expressions are not equivalent

113) Assistent #109823 "109823 - 2 Dist, 1 Comm, Y"

If the following two expressions are equivalent or not:

1. $2(3x + 2) + 14 + (-38x)$
2. $-36x + 18$

Yes, the two expressions are equivalent

No, the two expressions are not equivalent

114) Assistent #109824 "109824 - 2 Dist, 1 Comm, Y"

If the following two expressions are equivalent or not:

1. $5(3x + 10) + 36 + (-50x)$
2. $-39x + 86$

Yes, the two expressions are equivalent

No, the two expressions are not equivalent

115) Assistent #109825 "109825 - 2 Dist, 1 Comm, Y"

If the following two expressions are equivalent or not:

1. $6(5x + 4) + 60 + (-12x)$
2. $16x + 84$

Yes, the two expressions are equivalent

No, the two expressions are not equivalent

116) Assistent #109826 "109826 - 2 Dist, 1 Comm, Y"

If the following two expressions are equivalent or not:

1. $-6(10x + 2) + (-41) + 6x$
2. $-51x + (-53)$

Yes, the two expressions are equivalent

No, the two expressions are not equivalent

117) Assistent #109827 "109827 - 2 Dist, 1 Comm, Y"

If the following two expressions are equivalent or not:

1. $-1(2x + 3) + (-45) + (-6x)$
2. $-5x + (-48)$

Yes, the two expressions are equivalent

No, the two expressions are not equivalent

118) Assistent #109828 "109828 - 2 Dist, 1 Comm, Y"

If the following two expressions are equivalent or not:

1. $-6(3x + 4) + (-28) + 31x$
2. $14x + (-52)$

Yes, the two expressions are equivalent

No, the two expressions are not equivalent

119) Assistent #109829 "109829 - 2 Dist, 1 Comm, Y"

If the following two expressions are equivalent or not:

1. $-6(10x + 8) + (-44) + 32x$
2. $-25x + (-92)$

Yes, the two expressions are equivalent

No, the two expressions are not equivalent

120) Assisment #109830 "109830 - 2 Dist, 1 Comm, Y"

If the following two expressions are equivalent or not:

1. $-6(5x + 5) + (-41) + 20x$
2. $-9x + (-71)$

Yes, the two expressions are equivalent

No, the two expressions are not equivalent

Problem Set * , (, "Order of Operations - Basic" id:[6848]

1) Assistent #46401 "46401 - 46029 - Order of Operations"

$$(6 + 3)^2$$

2) Assistent #46402 "46402 - 46029 - Order of Operations"

$$(2 + 3)^2$$

3) Assistent #46403 "46403 - 46029 - Order of Operations"

$$(2 + 4)^2$$

4) Assistent #46404 "46404 - 46029 - Order of Operations"

$$(2 + 3)^2$$

5) Assistent #46405 "46405 - 46029 - Order of Operations"

$$(3 + 5)^2$$

6) Assistent #46406 "46406 - 46029 - Order of Operations"

$$(5 + 4)^2$$

7) Assistent #46407 "46407 - 46029 - Order of Operations"

$$(2 + 2)^2$$

8) Assistent #46408 "46408 - 46029 - Order of Operations"

$$(5 + 4)^2$$

9) Assistent #46409 "46409 - 46029 - Order of Operations"

$$(6 + 4)^2$$

10) Assistent #46410 "46410 - 46029 - Order of Operations"

$$(6 + 3)^2$$

11) Assistent #46411 "46411 - 45804 - Order of Operations"

$$4 \cdot 3 + 4^2$$

12) Assistent #46412 "46412 - 45804 - Order of Operations"

$$3 \cdot 2 + 3^2$$

13) Assistent #46413 "46413 - 45804 - Order of Operations"

$$3 \cdot 4 + 3^2$$

14) Assistent #46414 "46414 - 45804 - Order of Operations"

$$4 \cdot 2 + 4^2$$

15) Assistent #46415 "46415 - 45804 - Order of Operations"

$$2 \cdot 3 + 3^2$$

16) Assistent #46416 "46416 - 45804 - Order of Operations"

$$2 \cdot 3 + 2^2$$

17) Assistent #46417 "46417 - 45804 - Order of Operations"

$$3 \cdot 2 + 3^2$$

18) Assistent #46418 "46418 - 45804 - Order of Operations"

$$3 \cdot 2 + 2^2$$

19) Assisment #46419 "46419 - 45804 - Order of Operations"

$$3 \cdot 4 + 4^2$$

20) Assisment #46420 "46420 - 45804 - Order of Operations"

$$2 \cdot 2 + 3^2$$

21) Assisment #46421 "46421 - 45804 - Order of Operations"

$$2 \cdot 2 + 3^2$$

22) Assisment #46422 "46422 - 45804 - Order of Operations"

$$3 \cdot 3 + 2^2$$

23) Assisment #46423 "46423 - 45804 - Order of Operations"

$$3 \cdot 4 + 4^2$$

24) Assisment #46424 "46424 - 45804 - Order of Operations"

$$3 \cdot 4 + 2^2$$

25) Assisment #46425 "46425 - 45804 - Order of Operations"

$$4 \cdot 2 + 2^2$$

26) Assisment #46426 "46426 - 45804 - Order of Operations"

$$4 \cdot 2 + 3^2$$

27) Assisment #46427 "46427 - 45804 - Order of Operations"

$$4 \cdot 3 + 3^2$$

28) Assisment #46428 "46428 - 45804 - Order of Operations"

$$3 \cdot 4 + 2^2$$

29) Assisment #46429 "46429 - 45804 - Order of Operations"

$$4 \cdot 3 + 4^2$$

30) Assisment #46430 "46430 - 45804 - Order of Operations"

$$2 \cdot 2 + 3^2$$

31) Assisment #46441 "46441 - 29981 - Order of Operations: Addition & Multiplication"

What is the solution to the expression below?

$$2 + 5 \times 3$$

32) Assisment #46442 "46442 - 29981 - Order of Operations: Addition & Multiplication"

What is the solution to the expression below?

$$4 + 3 \times 6$$

33) Assisment #46443 "46443 - 29981 - Order of Operations: Addition & Multiplication"

What is the solution to the expression below?

$$2 + 2 \times 6$$

34) Assisment #46444 "46444 - 29981 - Order of Operations: Addition & Multiplication"

What is the solution to the expression below?

$$5 + 5 \times 4$$

35) Assisment #46445 "46445 - 29981 - Order of Operations: Addition & Multiplication"

What is the solution to the expression below?

$$2 + 6 \times 5$$

36) Assistent #46446 "46446 - 29981 - Order of Operations: Addition & Multiplication"

What is the solution to the expression below?

$$2 + 5 \times 2$$

37) Assistent #46447 "46447 - 29981 - Order of Operations: Addition & Multiplication"

What is the solution to the expression below?

$$4 + 4 \times 5$$

38) Assistent #46448 "46448 - 29981 - Order of Operations: Addition & Multiplication"

What is the solution to the expression below?

$$3 + 6 \times 2$$

39) Assistent #46449 "46449 - 29981 - Order of Operations: Addition & Multiplication"

What is the solution to the expression below?

$$4 + 2 \times 3$$

40) Assistent #46450 "46450 - 29981 - Order of Operations: Addition & Multiplication"

What is the solution to the expression below?

$$5 + 4 \times 4$$

41) Assistent #46691 "46691 - 46029 - Order of Operations"

$$(3 + 2)^2$$

42) Assistent #46692 "46692 - 46029 - Order of Operations"

$$(2 + 2)^2$$

43) Assistent #46693 "46693 - 46029 - Order of Operations"

$$(6 + 5)^2$$

44) Assistent #46694 "46694 - 46029 - Order of Operations"

$$(5 + 2)^2$$

45) Assistent #46695 "46695 - 46029 - Order of Operations"

$$(5 + 3)^2$$

46) Assistent #46696 "46696 - 46029 - Order of Operations"

$$(4 + 2)^2$$

47) Assistent #46697 "46697 - 46029 - Order of Operations"

$$(6 + 2)^2$$

48) Assistent #46698 "46698 - 46029 - Order of Operations"

$$(6 + 5)^2$$

49) Assistent #46699 "46699 - 46029 - Order of Operations"

$$(4 + 5)^2$$

50) Assistent #46700 "46700 - 46029 - Order of Operations"

$$(4 + 4)^2$$

51) Assistent #46701 "46701 - 46029 - Order of Operations"

$$(4 + 2)^2$$

52) Assisment #46702 "46702 - 46029 - Order of Operations"

$$(4 + 4)^2$$

53) Assisment #46703 "46703 - 46029 - Order of Operations"

$$(2 + 3)^2$$

54) Assisment #46704 "46704 - 46029 - Order of Operations"

$$(6 + 4)^2$$

55) Assisment #46705 "46705 - 46029 - Order of Operations"

$$(6 + 3)^2$$

56) Assisment #46706 "46706 - 46029 - Order of Operations"

$$(3 + 2)^2$$

57) Assisment #46707 "46707 - 46029 - Order of Operations"

$$(6 + 5)^2$$

58) Assisment #46708 "46708 - 46029 - Order of Operations"

$$(4 + 4)^2$$

59) Assisment #46709 "46709 - 46029 - Order of Operations"

$$(5 + 3)^2$$

60) Assisment #46710 "46710 - 46029 - Order of Operations"

$$(3 + 2)^2$$

61) Assisment #46731 "46731 - 29981 - Order of Operations: Addition & Multiplication"

What is the solution to the expression below?

$$2 + 4 \times 2$$

62) Assistent #46732 "46732 - 29981 - Order of Operations: Addition & Multiplication"

What is the solution to the expression below?

$$6 + 5 \times 3$$

63) Assistent #46733 "46733 - 29981 - Order of Operations: Addition & Multiplication"

What is the solution to the expression below?

$$4 + 5 \times 5$$

64) Assistent #46734 "46734 - 29981 - Order of Operations: Addition & Multiplication"

What is the solution to the expression below?

$$3 + 4 \times 5$$

65) Assistent #46735 "46735 - 29981 - Order of Operations: Addition & Multiplication"

What is the solution to the expression below?

$$3 + 4 \times 5$$

66) Assistent #46736 "46736 - 29981 - Order of Operations: Addition & Multiplication"

What is the solution to the expression below?

$$4 + 3 \times 3$$

67) Assistent #46737 "46737 - 29981 - Order of Operations: Addition & Multiplication"

What is the solution to the expression below?

$$3 + 4 \times 2$$

68) Assistent #46738 "46738 - 29981 - Order of Operations: Addition & Multiplication"

What is the solution to the expression below?

$$2 + 6 \times 4$$

69) Assistent #46739 "46739 - 29981 - Order of Operations: Addition & Multiplication"

What is the solution to the expression below?

$$5 + 2 \times 4$$

70) Assistent #46740 "46740 - 29981 - Order of Operations: Addition & Multiplication"

What is the solution to the expression below?

$$4 + 5 \times 2$$

71) Assistent #46748 "46748 - 29981 - Order of Operations: Addition & Multiplication"

What is the solution to the expression below?

$$5 + 4 \times 6$$

72) Assistent #46752 "46752 - 29981 - Order of Operations: Addition & Multiplication"

What is the solution to the expression below?

$$5 + 2 \times 3$$

73) Assistent #46753 "46753 - 29981 - Order of Operations: Addition & Multiplication"

What is the solution to the expression below?

$$4 + 5 \times 3$$

74) Assistent #46754 "46754 - 29981 - Order of Operations: Addition & Multiplication"

What is the solution to the expression below?

$$2 + 4 \times 6$$

75) Assistent #46755 "46755 - 29981 - Order of Operations: Addition & Multiplication"

What is the solution to the expression below?

$$4 + 5 \times 4$$

76) Assistent #46756 "46756 - 29981 - Order of Operations: Addition & Multiplication"

What is the solution to the expression below?

$$4 + 3 \times 5$$

77) Assistent #46757 "46757 - 29981 - Order of Operations: Addition & Multiplication"

What is the solution to the expression below?

$$2 + 2 \times 3$$

78) Assistent #46758 "46758 - 29981 - Order of Operations: Addition & Multiplication"

What is the solution to the expression below?

$$4 + 4 \times 5$$

79) Assisment #46759 "46759 - 29981 - Order of Operations: Addition & Multiplication"

What is the solution to the expression below?

$$3 + 4 \times 6$$

80) Assisment #46760 "46760 - 29981 - Order of Operations: Addition & Multiplication"

What is the solution to the expression below?

$$2 + 3 \times 4$$

81) Assisment #46782 "46782 - 45804 - Order of Operations"

$$4 \bullet 2 + 4^2$$

82) Assisment #46783 "46783 - 45804 - Order of Operations"

$$3 \bullet 2 + 2^2$$

83) Assisment #46784 "46784 - 45804 - Order of Operations"

$$4 \bullet 3 + 3^2$$

84) Assisment #46785 "46785 - 45804 - Order of Operations"

$$2 \bullet 2 + 2^2$$

85) Assisment #46789 "46789 - 45804 - Order of Operations"

$$2 \bullet 4 + 4^2$$

86) Assisment #46790 "46790 - 45804 - Order of Operations"

$$2 \bullet 2 + 2^2$$

87) Assistent #46791 "46791- 45804 - Order of Operations"

$$3 \cdot 2 + 2^2$$

Problem Set % +% "Definition: Distributive, Associative, Commutative"

1) Assistent #108029 "108029 - Which mathematica..."

Which **mathematical property** is used in the following equation?

$$(8 + 10) + 5 = 8 + (10 + 5)$$

Associative

Distributive

Commutative

2) Assistent #108030 "108030 - Which mathematica..."

Which **mathematical property** is used in the following equation?

$$(9 + 6) + 9 = 9 + (6 + 9)$$

Associative

Distributive

Commutative

3) Assistent #108031 "108031 - Which mathematica..."

Which **mathematical property** is used in the following equation?

$$(11 + 5) + 2 = 11 + (5 + 2)$$

Associative

Distributive

Commutative

4) Assistent #108032 "108032 - Which mathematica..."

Which **mathematical property** is used in the following equation?

$$(9 + 5) + 6 = 9 + (5 + 6)$$

Associative

Distributive

Commutative

5) Assistent #108033 "108033 - Which mathematica..."

Which **mathematical property** is used in the following equation?

$$(8 + 7) + 10 = 8 + (7 + 10)$$

Associative

Distributive

Commutative

6) Assistent #108034 "108034 - Which mathematica..."

Which **mathematical property** is used in the following equation?

$$(11 + 7) + 5 = 11 + (7 + 5)$$

Associative

Distributive

Commutative

7) Assistent #108035 "108035 - Which mathematica..."

Which **mathematical property** is used in the following equation?

$$(7 + 2) + 7 = 7 + (2 + 7)$$

Associative

Distributive

Commutative

8) Assistent #108037 "108037 - Which mathematica..."

Which **mathematical property** is used in the following equation?

$$(5 + 10) + 6 = 5 + (10 + 6)$$

Associative

Distributive

Commutative

9) Assistent #108038 "108038 - Which mathematica..."

Which **mathematical property** is used in the following equation?

$$(6 + 11) + 5 = 6 + (11 + 5)$$

Associative

Distributive

Commutative

10) Assistent #108039 "108039 - Which mathematica..."

Which **mathematical property** is used in the following equation?

$$(10 + 2) + 6 = 10 + (2 + 6)$$

Associative

Distributive
Commutative

11) Assistent #108040 "108040 - Which mathematica..."

Which **mathematical property** is used in the following equation?

$$(2 + 4) + 11 = 2 + (4 + 11)$$

Associative
Distributive
Commutative

12) Assistent #108041 "108041 - Which mathematica..."

Which **mathematical property** is used in the following equation?

$$(4 + 9) + 7 = 4 + (9 + 7)$$

Associative
Distributive
Commutative

13) Assistent #108042 "108042 - Which mathematica..."

Which **mathematical property** is used in the following equation?

$$(10 + 4) + 2 = 10 + (4 + 2)$$

Associative
Distributive
Commutative

14) Assistent #108043 "108043 - Which mathematica..."

Which **mathematical property** is used in the following equation?

$$(4 + 6) + 11 = 4 + (6 + 11)$$

Associative
Distributive
Commutative

15) Assistent #108044 "108044 - Which mathematica..."

Which **mathematical property** is used in the following equation?

$$(4 + 8x)9 = 36 + 72x$$

Distributive
Associative
Commutative

16) Assistent #108045 "108045 - Which mathematica..."

Which **mathematical property** is used in the following equation?

$$(5 + 5x)9 = 45 + 45x$$

Distributive

Associative

Commutative

17) Assistent #108046 "108046 - Which mathematica..."

Which **mathematical property** is used in the following equation?

$$(8 + 10x)7 = 56 + 70x$$

Distributive

Associative

Commutative

18) Assistent #108047 "108047 - Which mathematica..."

Which **mathematical property** is used in the following equation?

$$(2 + 7x)3 = 6 + 21x$$

Distributive

Associative

Commutative

19) Assistent #108048 "108048 - Which mathematica..."

Which **mathematical property** is used in the following equation?

$$(2 + 8x)9 = 18 + 72x$$

Distributive

Associative

Commutative

20) Assistent #108049 "108049 - Which mathematica..."

Which **mathematical property** is used in the following equation?

$$(3 + 6x)4 = 12 + 24x$$

Distributive

Associative

Commutative

21) Assistent #108050 "108050 - Which mathematica..."

Which **mathematical property** is used in the following equation?

$$(7 + 5x)9 = 63 + 45x$$

Distributive
Associative
Commutative

22) Assistent #108051 "108051 - Which mathematica..."

Which **mathematical property** is used in the following equation?

$$(2 + 3x)5 = 10 + 15x$$

Distributive
Associative
Commutative

23) Assistent #108052 "108052 - Which mathematica..."

Which **mathematical property** is used in the following equation?

$$(2 + 4x)11 = 22 + 44x$$

Distributive
Associative
Commutative

24) Assistent #108053 "108053 - Which mathematica..."

Which **mathematical property** is used in the following equation?

$$(4 + 7x)2 = 8 + 14x$$

Distributive
Associative
Commutative

25) Assistent #108054 "108054 - Which mathematica..."

Which **mathematical property** is used in the following equation?

$$(5 + 2x)11 = 55 + 22x$$

Distributive
Associative
Commutative

26) Assistent #108055 "108055 - Which mathematica..."

Which **mathematical property** is used in the following equation?

$$(11 + 4x)10 = 110 + 40x$$

Distributive
Associative
Commutative

27) Assistent #108056 "108056 - Which mathematica..."

Which **mathematical property** is used in the following equation?

$$(11 + 2x)5 = 55 + 10x$$

Distributive

Associative

Commutative

28) Assistent #108057 "108057 - Which mathematica..."

Which **mathematical property** is used in the following equation?

$$(8 + 7x)11 = 88 + 77x$$

Distributive

Associative

Commutative

29) Assistent #108058 "108058 - Which mathematica..."

Which **mathematical property** is used in the following equation?

$$(4 + 4x)4 = 16 + 16x$$

Distributive

Associative

Commutative

30) Assistent #108060 "108060 - Which mathematica..."

Which **mathematical property** is used in the following equation?

$$8(4*9) = (8*4)9$$

Associative

Distributive

Commutative

31) Assistent #108061 "108061 - Which mathematica..."

Which **mathematical property** is used in the following equation?

$$4(8*10) = (4*8)10$$

Associative

Distributive

Commutative

32) Assistent #108063 "108063 - Which mathematica..."

Which **mathematical property** is used in the following equation?

$$2(10 \cdot 9) = (2 \cdot 10)9$$

Associative

Distributive

Commutative

33) Assistent #108064 "108064 - Which mathematica..."

Which **mathematical property** is used in the following equation?

$$2(5 \cdot 4) = (2 \cdot 5)4$$

Associative

Distributive

Commutative

34) Assistent #108065 "108065 - Which mathematica..."

Which **mathematical property** is used in the following equation?

$$3(7 \cdot 6) = (3 \cdot 7)6$$

Associative

Distributive

Commutative

35) Assistent #108066 "108066 - Which mathematica..."

Which **mathematical property** is used in the following equation?

$$7(8 \cdot 10) = (7 \cdot 8)10$$

Associative

Distributive

Commutative

36) Assistent #108067 "108067 - Which mathematica..."

Which **mathematical property** is used in the following equation?

$$5(4 \cdot 11) = (5 \cdot 4)11$$

Associative

Distributive

Commutative

37) Assistent #108068 "108068 - Which mathematica..."

Which **mathematical property** is used in the following equation?

$$6(10 \cdot 7) = (6 \cdot 10)7$$

Associative

Distributive
Commutative

38) Assistent #108069 "108069 - Which mathematica..."

Which **mathematical property** is used in the following equation?

$$5(7*8) = (5*7)8$$

Associative
Distributive
Commutative

39) Assistent #108070 "108070 - Which mathematica..."

Which **mathematical property** is used in the following equation?

$$7(11*4) = (7*11)4$$

Associative
Distributive
Commutative

40) Assistent #108071 "108071 - Which mathematica..."

Which **mathematical property** is used in the following equation?

$$7(6*3) = (7*6)3$$

Associative
Distributive
Commutative

41) Assistent #108072 "108072 - Which mathematica..."

Which **mathematical property** is used in the following equation?

$$9(4*8) = (9*4)8$$

Associative
Distributive
Commutative

42) Assistent #108073 "108073 - Which mathematica..."

Which **mathematical property** is used in the following equation?

$$6(5*4) = (6*5)4$$

Associative
Distributive
Commutative

43) Assistent #108074 "108074 - Which mathematica..."

Which **mathematical property** is used in the following equation?

$$10 \cdot 11 \cdot 3 = 11 \cdot 10 \cdot 3$$

Commutative

Distributive

Associative

44) Assistent #108075 "108075 - Which mathematica..."

Which **mathematical property** is used in the following equation?

$$10 \cdot 3 \cdot 11 = 3 \cdot 10 \cdot 11$$

Commutative

Distributive

Associative

45) Assistent #108076 "108076 - Which mathematica..."

Which **mathematical property** is used in the following equation?

$$3 \cdot 10 \cdot 3 = 10 \cdot 3 \cdot 3$$

Commutative

Distributive

Associative

46) Assistent #108077 "108077 - Which mathematica..."

Which **mathematical property** is used in the following equation?

$$6 \cdot 8 \cdot 3 = 8 \cdot 6 \cdot 3$$

Commutative

Distributive

Associative

47) Assistent #108078 "108078 - Which mathematica..."

Which **mathematical property** is used in the following equation?

$$7 \cdot 3 \cdot 2 = 3 \cdot 7 \cdot 2$$

Commutative

Distributive

Associative

48) Assistent #108079 "108079 - Which mathematica..."

Which **mathematical property** is used in the following equation?

$$6 \cdot 2 \cdot 11 = 2 \cdot 6 \cdot 11$$

Commutative
Distributive
Associative

49) Assistent #108081 "108081 - Which mathematica..."

Which **mathematical property** is used in the following equation?

$$8*7*11 = 7*8*11$$

Commutative
Distributive
Associative

50) Assistent #108083 "108083 - Which mathematica..."

Which **mathematical property** is used in the following equation?

$$3*5*9 = 5*3*9$$

Commutative
Distributive
Associative

51) Assistent #108084 "108084 - Which mathematica..."

Which **mathematical property** is used in the following equation?

$$3*5*4 = 5*3*4$$

Commutative
Distributive
Associative

52) Assistent #108085 "108085 - Which mathematica..."

Which **mathematical property** is used in the following equation?

$$11*10*3 = 10*11*3$$

Commutative
Distributive
Associative

53) Assistent #108086 "108086 - Which mathematica..."

Which **mathematical property** is used in the following equation?

$$2*9*7 = 9*2*7$$

Commutative
Distributive
Associative

54) Assistent #108087 "108087 - Which mathematica..."

Which **mathematical property** is used in the following equation?

$$11 \cdot 8 \cdot 4 = 8 \cdot 11 \cdot 4$$

Commutative

Distributive

Associative

55) Assistent #108089 "108089 - Which of the foll..."

Which of the following answers correctly uses the **associative property**?

$$8 + (7 + 2) = (8 + 7) + 2$$

$$3 + (5 + 5) = 8 + 8$$

$$9 \cdot 4 = 4 - 9$$

$$11 \cdot 6 \cdot 2 = 6 \cdot 2 \cdot 11$$

$$5(3x + 7) = 15x + 35$$

$$9(11x + 2) = (9 \cdot 11x) + 2$$

56) Assistent #108090 "108090 - Which of the foll..."

Which of the following answers correctly uses the **associative property**?

$$8 + (5 + 7) = (8 + 5) + 7$$

$$9 + (9 + 6) = 18 + 15$$

$$9 \cdot 6 = 6 - 9$$

$$5 \cdot 3 \cdot 7 = 3 \cdot 7 \cdot 5$$

$$5(9x + 11) = 45x + 55$$

$$11(9x + 3) = (11 \cdot 9x) + 3$$

57) Assistent #108091 "108091 - Which of the foll..."

Which of the following answers correctly uses the **associative property**?

$$6 + (10 + 5) = (6 + 10) + 5$$

$$4 + (5 + 7) = 9 + 11$$

$$2 \cdot 9 = 9 - 2$$

$$2 \cdot 4 \cdot 10 = 4 \cdot 10 \cdot 2$$

$$7(2x + 11) = 14x + 77$$

$$7(10x + 7) = (7 \cdot 10x) + 7$$

58) Assistent #108092 "108092 - Which of the foll..."

Which of the following answers correctly uses the **associative property**?

$$9 + (5 + 10) = (9 + 5) + 10$$

$$3 + (4 + 7) = 7 + 10$$

$$4*6 = 6 - 4$$

$$2*3*2 = 3*2*2$$

$$6(5x + 2) = 30x + 12$$

$$11(2x + 6) = (11*2x) + 6$$

59) Assistent #108093 "108093 - Which of the foll..."

Which of the following answers correctly uses the [associative property](#)?

$$9 + (8 + 3) = (9 + 8) + 3$$

$$6 + (5 + 11) = 11 + 17$$

$$10*2 = 2 - 10$$

$$10*2*9 = 2*9*10$$

$$4(10x + 11) = 40x + 44$$

$$5(10x + 4) = (5*10x) + 4$$

60) Assistent #108094 "108094 - Which of the foll..."

Which of the following answers correctly uses the [associative property](#)?

$$3 + (2 + 6) = (3 + 2) + 6$$

$$11 + (9 + 8) = 20 + 19$$

$$11*8 = 8 - 11$$

$$9*2*5 = 2*5*9$$

$$5(11x + 2) = 55x + 10$$

$$5(3x + 4) = (5*3x) + 4$$

61) Assistent #108095 "108095 - Which of the foll..."

Which of the following answers correctly uses the [associative property](#)?

$$11 + (11 + 8) = (11 + 11) + 8$$

$$10 + (5 + 4) = 15 + 14$$

$$8*11 = 11 - 8$$

$$5*2*8 = 2*8*5$$

$$6(4x + 3) = 24x + 18$$

$$10(6x + 7) = (10*6x) + 7$$

62) Assistent #108096 "108096 - Which of the foll..."

Which of the following answers correctly uses the [associative property](#)?

$$6 + (9 + 3) = (6 + 9) + 3$$

$$2 + (4 + 11) = 6 + 13$$

$$9*8 = 8 - 9$$

$$4*8*2 = 8*2*4$$

$$6(5x + 10) = 30x + 60$$

$$7(5x + 10) = (7*5x) + 10$$

63) Assisment #108097 "108097 - Which of the foll..."

Which of the following answers correctly uses the [associative property](#)?

$$9 + (9 + 8) = (9 + 9) + 8$$

$$9 + (9 + 8) = 18 + 17$$

$$9*3 = 3 - 9$$

$$4*10*3 = 10*3*4$$

$$7(2x + 9) = 14x + 63$$

$$10(10x + 2) = (10*10x) + 2$$

64) Assisment #108098 "108098 - Which of the foll..."

Which of the following answers correctly uses the [associative property](#)?

$$2 + (4 + 11) = (2 + 4) + 11$$

$$5 + (3 + 4) = 8 + 9$$

$$9*10 = 10 - 9$$

$$9*3*10 = 3*10*9$$

$$4(8x + 2) = 32x + 8$$

$$5(6x + 4) = (5*6x) + 4$$

65) Assisment #108099 "108099 - Which of the foll..."

Which of the following answers correctly uses the [associative property](#)?

$$7 + (5 + 11) = (7 + 5) + 11$$

$$4 + (8 + 7) = 12 + 11$$

$$3*11 = 11 - 3$$

$$4*7*8 = 7*8*4$$

$$7(3x + 3) = 21x + 21$$

$$4(5x + 2) = (4*5x) + 2$$

66) Assisment #108100 "108100 - Which of the foll..."

Which of the following answers correctly uses the [associative property](#)?

$$10 + (9 + 9) = (10 + 9) + 9$$

$$7 + (3 + 2) = 10 + 9$$

$$10*6 = 6 - 10$$

$$8*10*11 = 10*11*8$$

$$9(2x + 3) = 18x + 27$$

$$10(8x + 6) = (10*8x) + 6$$

67) Assisment #108101 "108101 - Which of the foll..."

Which of the following answers correctly uses the [associative property](#)?

$$5 + (7 + 8) = (5 + 7) + 8$$

$$2 + (6 + 4) = 8 + 6$$

$$5 \cdot 3 = 3 - 5$$

$$10 \cdot 8 \cdot 7 = 8 \cdot 7 \cdot 10$$

$$6(7x + 10) = 42x + 60$$

$$11(4x + 2) = (11 \cdot 4x) + 2$$

68) Assistent #108102 "108102 - Which of the foll..."

Which of the following answers correctly uses the [associative property](#)?

$$5 + (10 + 10) = (5 + 10) + 10$$

$$6 + (8 + 8) = 14 + 14$$

$$8 \cdot 4 = 4 - 8$$

$$5 \cdot 9 \cdot 11 = 9 \cdot 11 \cdot 5$$

$$2(2x + 8) = 4x + 16$$

$$9(4x + 11) = (9 \cdot 4x) + 11$$

69) Assistent #108103 "108103 - Which of the foll..."

Which of the following answers correctly uses the [associative property](#)?

$$3 + (3 + 2) = (3 + 3) + 2$$

$$5 + (4 + 2) = 9 + 7$$

$$7 \cdot 4 = 4 - 7$$

$$11 \cdot 11 \cdot 10 = 11 \cdot 10 \cdot 11$$

$$4(7x + 7) = 28x + 28$$

$$9(9x + 2) = (9 \cdot 9x) + 2$$

70) Assistent #108106 "108106 - Which mathematica..."

Which [mathematical property](#) is used in the following equation?

$$8 + 7 = 7 + 8$$

Commutative

Associative

Distributive

71) Assistent #108107 "108107 - Which mathematica..."

Which [mathematical property](#) is used in the following equation?

$$4 + 8 = 8 + 4$$

Commutative

Associative

Distributive

72) Assistent #108108 "108108 - Which mathematica..."

Which **mathematical property** is used in the following equation?

$$11 + 6 = 6 + 11$$

Commutative

Associative

Distributive

73) Assistent #108109 "108109 - Which mathematica..."

Which **mathematical property** is used in the following equation?

$$3 + 2 = 2 + 3$$

Commutative

Associative

Distributive

74) Assistent #108110 "108110 - Which mathematica..."

Which **mathematical property** is used in the following equation?

$$5 + 8 = 8 + 5$$

Commutative

Associative

Distributive

75) Assistent #108111 "108111 - Which mathematica..."

Which **mathematical property** is used in the following equation?

$$7 + 3 = 3 + 7$$

Commutative

Associative

Distributive

76) Assistent #108112 "108112 - Which mathematica..."

Which **mathematical property** is used in the following equation?

$$5 + 3 = 3 + 5$$

Commutative

Associative

Distributive

77) Assistent #108113 "108113 - Which mathematica..."

Which **mathematical property** is used in the following equation?

$$7 + 11 = 11 + 7$$

Commutative

Associative

Distributive

78) Assistent #108115 "108115 - Which mathematica..."

Which **mathematical property** is used in the following equation?

$$7 + 6 = 6 + 7$$

Commutative

Associative

Distributive

79) Assistent #108116 "108116 - Which mathematica..."

Which **mathematical property** is used in the following equation?

$$10 + 9 = 9 + 10$$

Commutative

Associative

Distributive

80) Assistent #108117 "108117 - Which mathematica..."

Which **mathematical property** is used in the following equation?

$$7 + 8 = 8 + 7$$

Commutative

Associative

Distributive

81) Assistent #108118 "108118 - Which mathematica..."

Which **mathematical property** is used in the following equation?

$$7 + 5 = 5 + 7$$

Commutative

Associative

Distributive

82) Assistent #108119 "108119 - Which mathematica..."

Which **mathematical property** is used in the following equation?

$$8(3x + 8y) = 24x + 64y$$

Distributive

Associative
Commutative

83) Assistent #108120 "108120 - Which mathematica..."

Which **mathematical property** is used in the following equation?

$$11(8x + 4y) = 88x + 44y$$

Distributive
Associative
Commutative

84) Assistent #108121 "108121 - Which mathematica..."

Which **mathematical property** is used in the following equation?

$$5(2x + 7y) = 10x + 35y$$

Distributive
Associative
Commutative

85) Assistent #108122 "108122 - Which mathematica..."

Which **mathematical property** is used in the following equation?

$$3(3x + 2y) = 9x + 6y$$

Distributive
Associative
Commutative

86) Assistent #108123 "108123 - Which mathematica..."

Which **mathematical property** is used in the following equation?

$$11(10x + 4y) = 110x + 44y$$

Distributive
Associative
Commutative

87) Assistent #108124 "108124 - Which mathematica..."

Which **mathematical property** is used in the following equation?

$$11(10x + 11y) = 110x + 121y$$

Distributive
Associative
Commutative

88) Assistent #108125 "108125 - Which mathematica..."

Which **mathematical property** is used in the following equation?

$$11(11x + 11y) = 121x + 121y$$

Distributive

Associative

Commutative

89) Assistent #108126 "108126 - Which mathematica..."

Which **mathematical property** is used in the following equation?

$$6(5x + 5y) = 30x + 30y$$

Distributive

Associative

Commutative

90) Assistent #108127 "108127 - Which mathematica..."

Which **mathematical property** is used in the following equation?

$$6(6x + 5y) = 36x + 30y$$

Distributive

Associative

Commutative

91) Assistent #108128 "108128 - Which mathematica..."

Which **mathematical property** is used in the following equation?

$$3(8x + 9y) = 24x + 27y$$

Distributive

Associative

Commutative

92) Assistent #108129 "108129 - Which mathematica..."

Which **mathematical property** is used in the following equation?

$$11(5x + 2y) = 55x + 22y$$

Distributive

Associative

Commutative

93) Assistent #108130 "108130 - Which mathematica..."

Which **mathematical property** is used in the following equation?

$$7(2x + 7y) = 14x + 49y$$

Distributive
Associative
Commutative

94) Assistent #108131 "108131 - Which mathematica..."

Which **mathematical property** is used in the following equation?

$$8(11x + 6y) = 88x + 48y$$

Distributive
Associative
Commutative

95) Assistent #108132 "108132 - Which mathematica..."

Which **mathematical property** is used in the following equation?

$$10(2x + 2y) = 20x + 20y$$

Distributive
Associative
Commutative

96) Assistent #108133 "108133 - Which mathematica..."

Which **mathematical property** is used in the following equation?

$$11(3x + 2y) = 33x + 22y$$

Distributive
Associative
Commutative

97) Assistent #108134 "108134 - Which of the foll..."

Which of the following answers correctly uses the the **distributive property**?

$$2(6x + 3) = 12x + 6$$

$$2*3 = 3*2$$

$$5 + (11 + 6) = (5 + 11) + 6$$

$$9(5x + 2) = 14x + 11$$

$$6 + (8 + 11) = 14 + 17$$

$$5*10 = 10 - 5$$

98) Assistent #108135 "108135 - Which of the foll..."

Which of the following answers correctly uses the the **distributive property**?

$$6(3x + 10) = 18x + 60$$

$$11*7 = 7*11$$

$$5 + (11 + 5) = (5 + 11) + 5$$

$$11(8x + 3) = 19x + 14$$

$$11 + (9 + 6) = 20 + 17$$

$$4*11 = 11 - 4$$

99) Assistent #108136 "108136 - Which of the foll..."

Which of the following answers correctly uses the the [distributive property](#)?

$$3(5x + 10) = 15x + 30$$

$$5*2 = 2*5$$

$$5 + (2 + 9) = (5 + 2) + 9$$

$$7(6x + 11) = 13x + 18$$

$$7 + (3 + 9) = 10 + 16$$

$$2*8 = 8 - 2$$

100) Assistent #108137 "108137 - Which of the foll..."

Which of the following answers correctly uses the the [distributive property](#)?

$$2(9x + 8) = 18x + 16$$

$$8*11 = 11*8$$

$$5 + (3 + 10) = (5 + 3) + 10$$

$$11(9x + 6) = 20x + 17$$

$$7 + (10 + 5) = 17 + 12$$

$$3*8 = 8 - 3$$

101) Assistent #108138 "108138 - Which of the foll..."

Which of the following answers correctly uses the the [distributive property](#)?

$$5(3x + 2) = 15x + 10$$

$$8*8 = 8*8$$

$$9 + (5 + 6) = (9 + 5) + 6$$

$$3(2x + 9) = 5x + 12$$

$$8 + (6 + 11) = 14 + 19$$

$$11*2 = 2 - 11$$

102) Assistent #108139 "108139 - Which of the foll..."

Which of the following answers correctly uses the the [distributive property](#)?

$$5(2x + 9) = 10x + 45$$

$$4*10 = 10*4$$

$$7 + (3 + 5) = (7 + 3) + 5$$

$$3(4x + 3) = 7x + 6$$

$$5 + (4 + 4) = 9 + 9$$

$$8*10 = 10 - 8$$

103) Assistent #108140 "108140 - Which of the foll..."

Which of the following answers correctly uses the the [distributive property](#)?

$$7(3x + 10) = 21x + 70$$

$$4*2 = 2*4$$

$$7 + (6 + 6) = (7 + 6) + 6$$

$$3(4x + 2) = 7x + 5$$

$$9 + (11 + 5) = 20 + 14$$

$$5*7 = 7 - 5$$

104) Assistent #108141 "108141 - Which of the foll..."

Which of the following answers correctly uses the the [distributive property](#)?

$$8(10x + 7) = 80x + 56$$

$$11*7 = 7*11$$

$$6 + (7 + 9) = (6 + 7) + 9$$

$$3(2x + 7) = 5x + 10$$

$$11 + (8 + 3) = 19 + 14$$

$$5*9 = 9 - 5$$

105) Assistent #108142 "108142 - Which of the foll..."

Which of the following answers correctly uses the the [distributive property](#)?

$$10(7x + 7) = 70x + 70$$

$$3*5 = 5*3$$

$$11 + (2 + 3) = (11 + 2) + 3$$

$$8(3x + 10) = 11x + 18$$

$$2 + (3 + 5) = 5 + 7$$

$$3*8 = 8 - 3$$

106) Assistent #108143 "108143 - Which of the foll..."

Which of the following answers correctly uses the the [distributive property](#)?

$$7(11x + 4) = 77x + 28$$

$$2*5 = 5*2$$

$$7 + (2 + 3) = (7 + 2) + 3$$

$$4(11x + 3) = 15x + 7$$

$$7 + (5 + 11) = 12 + 18$$

$$3*10 = 10 - 3$$

107) Assistent #108144 "108144 - Which of the foll..."

Which of the following answers correctly uses the the [distributive property](#)?

$$11(4x + 6) = 44x + 66$$

$$7 \cdot 9 = 9 \cdot 7$$

$$3 + (6 + 6) = (3 + 6) + 6$$

$$2(9x + 3) = 11x + 5$$

$$9 + (3 + 8) = 12 + 17$$

$$9 \cdot 5 = 5 - 9$$

108) Assistent #108145 "108145 - Which of the foll..."

Which of the following answers correctly uses the the [distributive property](#)?

$$11(4x + 5) = 44x + 55$$

$$10 \cdot 4 = 4 \cdot 10$$

$$2 + (7 + 3) = (2 + 7) + 3$$

$$4(4x + 9) = 8x + 13$$

$$7 + (9 + 11) = 16 + 18$$

$$11 \cdot 7 = 7 - 11$$

109) Assistent #108146 "108146 - Which of the foll..."

Which of the following answers correctly uses the the [distributive property](#)?

$$6(3x + 6) = 18x + 36$$

$$4 \cdot 6 = 6 \cdot 4$$

$$2 + (3 + 3) = (2 + 3) + 3$$

$$5(7x + 5) = 12x + 10$$

$$11 + (9 + 11) = 20 + 22$$

$$11 \cdot 6 = 6 - 11$$

110) Assistent #108147 "108147 - Which of the foll..."

Which of the following answers correctly uses the the [distributive property](#)?

$$3(8x + 4) = 24x + 12$$

$$7 \cdot 6 = 6 \cdot 7$$

$$10 + (8 + 11) = (10 + 8) + 11$$

$$4(7x + 7) = 11x + 11$$

$$6 + (3 + 5) = 9 + 11$$

$$10 \cdot 9 = 9 - 10$$

111) Assistent #108148 "108148 - Which of the foll..."

Which of the following answers correctly uses the the [distributive property](#)?

$$2(5x + 10) = 10x + 20$$

$$8 \cdot 10 = 10 \cdot 8$$

$$5 + (9 + 8) = (5 + 9) + 8$$

$$6(5x + 7) = 11x + 13$$

$$7 + (2 + 2) = 9 + 9$$

$$4*9 = 9 - 4$$

112) Assistent #108149 "108149 - Which of the foll..."

Which of the following answers correctly uses the [commutative property](#)?

$$6*2*11 = 11*6*2$$

$$6*2*6 = (6 + 6) + 2$$

$$6 + (7 + 5) = 5 + (6 + 7)$$

$$10 + (9 + 3) = 19 + 13$$

$$8(3x + 7) = 24x + 56$$

$$2(11x + 4) = 4(2 + 11x)$$

113) Assistent #108150 "108150 - Which of the foll..."

Which of the following answers correctly uses the [commutative property](#)?

$$5*6*4 = 4*5*6$$

$$2*5*4 = (4 + 2) + 5$$

$$11 + (5 + 4) = 4 + (11 + 5)$$

$$9 + (7 + 7) = 16 + 16$$

$$8(8x + 7) = 64x + 56$$

$$10(8x + 4) = 4(10 + 8x)$$

114) Assistent #108151 "108151 - Which of the foll..."

Which of the following answers correctly uses the [commutative property](#)?

$$4*10*6 = 6*4*10$$

$$9*8*2 = (2 + 9) + 8$$

$$4 + (5 + 8) = 8 + (4 + 5)$$

$$9 + (7 + 6) = 16 + 15$$

$$10(10x + 2) = 100x + 20$$

$$6(9x + 10) = 10(6 + 9x)$$

115) Assistent #108152 "108152 - Which of the foll..."

Which of the following answers correctly uses the [commutative property](#)?

$$2*9*10 = 10*2*9$$

$$6*2*3 = (3 + 6) + 2$$

$$8 + (10 + 7) = 7 + (8 + 10)$$

$$4 + (3 + 8) = 7 + 12$$

$$9(11x + 6) = 99x + 54$$

$$10(9x + 4) = 4(10 + 9x)$$

116) Assistent #108153 "108153 - Which of the foll..."

Which of the following answers correctly uses the [commutative property](#)?

$$8*6*7 = 7*8*6$$

$$11*11*10 = (10 + 11) + 11$$

$$7 + (4 + 5) = 5 + (7 + 4)$$

$$3 + (10 + 2) = 13 + 5$$

$$7(10x + 9) = 70x + 63$$

$$4(5x + 6) = 6(4 + 5x)$$

117) Assistent #108154 "108154 - Which of the foll..."

Which of the following answers correctly uses the [commutative property](#)?

$$6*3*6 = 6*6*3$$

$$6*9*7 = (7 + 6) + 9$$

$$8 + (9 + 5) = 5 + (8 + 9)$$

$$11 + (7 + 8) = 18 + 19$$

$$3(4x + 10) = 12x + 30$$

$$11(9x + 11) = 11(11 + 9x)$$

118) Assistent #108155 "108155 - Which of the foll..."

Which of the following answers correctly uses the [commutative property](#)?

$$6*8*5 = 5*6*8$$

$$8*4*11 = (11 + 8) + 4$$

$$5 + (8 + 6) = 6 + (5 + 8)$$

$$2 + (4 + 5) = 6 + 7$$

$$6(4x + 7) = 24x + 42$$

$$9(7x + 4) = 4(9 + 7x)$$

119) Assistent #108156 "108156 - Which of the foll..."

Which of the following answers correctly uses the [commutative property](#)?

$$11*7*8 = 8*11*7$$

$$6*8*3 = (3 + 6) + 8$$

$$11 + (4 + 11) = 11 + (11 + 4)$$

$$11 + (2 + 9) = 13 + 20$$

$$3(11x + 10) = 33x + 30$$

$$10(8x + 5) = 5(10 + 8x)$$

120) Assistent #108157 "108157 - Which of the foll..."

Which of the following answers correctly uses the [commutative property](#)?

$$4 \cdot 2 \cdot 6 = 6 \cdot 4 \cdot 2$$

$$3 \cdot 10 \cdot 3 = (3 + 3) + 10$$

$$3 + (5 + 9) = 9 + (3 + 5)$$

$$3 + (7 + 11) = 10 + 14$$

$$10(4x + 4) = 40x + 40$$

$$6(4x + 5) = 5(6 + 4x)$$

121) Assistent #108158 "108158 - Which of the foll..."

Which of the following answers correctly uses the [commutative property](#)?

$$8 \cdot 11 \cdot 2 = 2 \cdot 8 \cdot 11$$

$$11 \cdot 7 \cdot 10 = (10 + 11) + 7$$

$$11 + (6 + 10) = 10 + (11 + 6)$$

$$10 + (11 + 6) = 21 + 16$$

$$2(11x + 10) = 22x + 20$$

$$4(11x + 8) = 8(4 + 11x)$$

122) Assistent #108159 "108159 - Which of the foll..."

Which of the following answers correctly uses the [commutative property](#)?

$$10 \cdot 8 \cdot 9 = 9 \cdot 10 \cdot 8$$

$$10 \cdot 4 \cdot 6 = (6 + 10) + 4$$

$$2 + (9 + 9) = 9 + (2 + 9)$$

$$3 + (2 + 6) = 5 + 9$$

$$2(9x + 10) = 18x + 20$$

$$9(11x + 8) = 8(9 + 11x)$$

123) Assistent #108160 "108160 - Which of the foll..."

Which of the following answers correctly uses the [commutative property](#)?

$$3 \cdot 9 \cdot 7 = 7 \cdot 3 \cdot 9$$

$$10 \cdot 10 \cdot 9 = (9 + 10) + 10$$

$$11 + (10 + 7) = 7 + (11 + 10)$$

$$4 + (5 + 7) = 9 + 11$$

$$7(2x + 4) = 14x + 28$$

$$8(3x + 8) = 8(8 + 3x)$$

124) Assistent #108161 "108161 - Which of the foll..."

Which of the following answers correctly uses the [commutative property](#)?

$$8 \cdot 8 \cdot 7 = 7 \cdot 8 \cdot 8$$

$$4 \cdot 4 \cdot 6 = (6 + 4) + 4$$

$$9 + (2 + 9) = 9 + (9 + 2)$$

$$7 + (9 + 7) = 16 + 14$$

$$2(10x + 8) = 20x + 16$$

$$8(5x + 9) = 9(8 + 5x)$$

125) Assistent #108162 "108162 - Which of the foll..."

Which of the following answers correctly uses the [commutative property](#)?

$$10*5*10 = 10*10*5$$

$$6*2*8 = (8 + 6) + 2$$

$$11 + (10 + 5) = 5 + (11 + 10)$$

$$3 + (11 + 11) = 14 + 14$$

$$10(5x + 3) = 50x + 30$$

$$4(2x + 10) = 10(4 + 2x)$$

126) Assistent #108163 "108163 - Which of the foll..."

Which of the following answers correctly uses the [commutative property](#)?

$$4*10*10 = 10*4*10$$

$$9*11*9 = (9 + 9) + 11$$

$$2 + (7 + 11) = 11 + (2 + 7)$$

$$5 + (8 + 3) = 13 + 8$$

$$9(4x + 5) = 36x + 45$$

$$5(7x + 8) = 8(5 + 7x)$$

127) Assistent #111276 "111276 - addition"

Here is one way you might prove that $8(7s+6) + 8s$ is equivalent to $64s + 48$

$$\begin{aligned} (1) \quad 8(7s+6) + 8s &= 56s + 48 + 8s \\ (2) &= 56s + 8s + 48 \\ (3) &= (56 + 8) s + 48 \\ (4) &= 64s + 48 \end{aligned}$$

What properties of numbers and operations justify from the [green](#) to [orange](#) line (from step 3 to step 4)?

Distributive Property

Addition

Associative Property

Commutative Property

128) Assistent #111277 "111277 - addition"

Here is one way you might prove that $6(6s+6) + 8s$ is equivalent to $44s + 36$

$$\begin{aligned} (1) \quad 6(6s+6) + 8s &= 36s + 36 + 8s \\ (2) &= 36s + 8s + 36 \\ (3) &= (36 + 8) s + 36 \\ (4) &= 44s + 36 \end{aligned}$$

What properties of numbers and operations justify from the [green](#) to [orange](#) line (from step 3 to step 4)?

Distributive Property
Addition
Associative Property
Commutative Property

129) Assistent #111278 "111278 - addition"

Here is one way you might prove that $5(7s+9) + 8s$ is equivalent to $43s + 45$

$$\begin{aligned}(1) \quad 5(7s+9) + 8s &= 35s + 45 + 8s \\(2) \quad &= 35s + 8s + 45 \\(3) \quad &= (35 + 8) s + 45 \\(4) \quad &= 43s + 45\end{aligned}$$

What properties of numbers and operations justify from the green to orange line (from step 3 to step 4)?

Distributive Property
Addition
Associative Property
Commutative Property

130) Assistent #111279 "111279 - addition"

Here is one way you might prove that $7(6s+5) + 6s$ is equivalent to $48s + 35$

$$\begin{aligned}(1) \quad 7(6s+5) + 6s &= 42s + 35 + 6s \\(2) \quad &= 42s + 6s + 35 \\(3) \quad &= (42 + 6) s + 35 \\(4) \quad &= 48s + 35\end{aligned}$$

What properties of numbers and operations justify from the green to orange line (from step 3 to step 4)?

Distributive Property
Addition
Associative Property
Commutative Property

131) Assistent #111280 "111280 - addition"

Here is one way you might prove that $6(5s+7) + 8s$ is equivalent to $38s + 42$

$$\begin{aligned}(1) \quad 6(5s+7) + 8s &= 30s + 42 + 8s \\(2) \quad &= 30s + 8s + 42 \\(3) \quad &= (30 + 8) s + 42 \\(4) \quad &= 38s + 42\end{aligned}$$

What properties of numbers and operations justify from the green to orange line (from step 3 to step 4)?

Distributive Property
Addition
Associative Property
Commutative Property

132) Assistent #111281 "111281 - addition"

Here is one way you might prove that $5(6s+7) + 5s$ is equivalent to $35s + 35$

$$\begin{aligned}(1) \quad 5(6s+7) + 5s &= 30s + 35 + 5s \\(2) \quad &= 30s + 5s + 35 \\(3) \quad &= (30 + 5) s + 35 \\(4) \quad &= 35s + 35\end{aligned}$$

What properties of numbers and operations justify from the green to orange line (from step 3 to step 4)?

Distributive Property

Addition

Associative Property

Commutative Property

133) Assistent #111282 "111282 - addition"

Here is one way you might prove that $9(8s+9) + 5s$ is equivalent to $77s + 81$

$$\begin{aligned}(1) \quad 9(8s+9) + 5s &= 72s + 81 + 5s \\(2) \quad &= 72s + 5s + 81 \\(3) \quad &= (72 + 5) s + 81 \\(4) \quad &= 77s + 81\end{aligned}$$

What properties of numbers and operations justify from the green to orange line (from step 3 to step 4)?

Distributive Property

Addition

Associative Property

Commutative Property

134) Assistent #111283 "111283 - addition"

Here is one way you might prove that $8(6s+7) + 5s$ is equivalent to $53s + 56$

$$\begin{aligned}(1) \quad 8(6s+7) + 5s &= 48s + 56 + 5s \\(2) \quad &= 48s + 5s + 56 \\(3) \quad &= (48 + 5) s + 56 \\(4) \quad &= 53s + 56\end{aligned}$$

What properties of numbers and operations justify from the green to orange line (from step 3 to step 4)?

Distributive Property

Addition

Associative Property

Commutative Property

135) Assistent #111284 "111284 - addition"

Here is one way you might prove that $5(8s+7) + 7s$ is equivalent to $47s + 35$

$$\begin{aligned}(1) \quad 5(8s+7) + 7s &= 40s + 35 + 7s \\(2) \quad &= 40s + 7s + 35 \\(3) \quad &= (40 + 7) s + 35\end{aligned}$$

$$(4) \quad = 47s + 35$$

What properties of numbers and operations justify from the green to orange line (from step 3 to step 4)?

Distributive Property

Addition

Associative Property

Commutative Property

136) Assistent #111285 "111285 - addition"

Here is one way you might prove that $6(8s+5) + 7s$ is equivalent to $55s + 30$

$$(1) \quad 6(8s+5) + 7s = 48s + 30 + 7s$$

$$(2) \quad = 48s + 7s + 30$$

$$(3) \quad = (48 + 7) s + 30$$

$$(4) \quad = 55s + 30$$

What properties of numbers and operations justify from the green to orange line (from step 3 to step 4)?

Distributive Property

Addition

Associative Property

Commutative Property

137) Assistent #111286 "111286 - addition"

Here is one way you might prove that $8(9s+5) + 5s$ is equivalent to $77s + 40$

$$(1) \quad 8(9s+5) + 5s = 72s + 40 + 5s$$

$$(2) \quad = 72s + 5s + 40$$

$$(3) \quad = (72 + 5) s + 40$$

$$(4) \quad = 77s + 40$$

What properties of numbers and operations justify from the green to orange line (from step 3 to step 4)?

Distributive Property

Addition

Associative Property

Commutative Property

138) Assistent #111287 "111287 - addition"

Here is one way you might prove that $9(7s+6) + 5s$ is equivalent to $68s + 54$

$$(1) \quad 9(7s+6) + 5s = 63s + 54 + 5s$$

$$(2) \quad = 63s + 5s + 54$$

$$(3) \quad = (63 + 5) s + 54$$

$$(4) \quad = 68s + 54$$

What properties of numbers and operations justify from the green to orange line (from step 3 to step 4)?

Distributive Property

Addition

Associative Property
Commutative Property

139) Assistent #111288 "111288 - addition"

Here is one way you might prove that $6(6s+7) + 8s$ is equivalent to $44s + 42$

$$\begin{aligned}(1) \quad 6(6s+7) + 8s &= 36s + 42 + 8s \\(2) \quad &= 36s + 8s + 42 \\(3) \quad &= (36 + 8) s + 42 \\(4) \quad &= 44s + 42\end{aligned}$$

What properties of numbers and operations justify from the green to orange line (from step 3 to step 4)?

Distributive Property
Addition
Associative Property
Commutative Property

140) Assistent #111289 "111289 - addition"

Here is one way you might prove that $6(6s+8) + 8s$ is equivalent to $44s + 48$

$$\begin{aligned}(1) \quad 6(6s+8) + 8s &= 36s + 48 + 8s \\(2) \quad &= 36s + 8s + 48 \\(3) \quad &= (36 + 8) s + 48 \\(4) \quad &= 44s + 48\end{aligned}$$

What properties of numbers and operations justify from the green to orange line (from step 3 to step 4)?

Distributive Property
Addition
Associative Property
Commutative Property

141) Assistent #111290 "111290 - addition"

Here is one way you might prove that $9(9s+9) + 9s$ is equivalent to $90s + 81$

$$\begin{aligned}(1) \quad 9(9s+9) + 9s &= 81s + 81 + 9s \\(2) \quad &= 81s + 9s + 81 \\(3) \quad &= (81 + 9) s + 81 \\(4) \quad &= 90s + 81\end{aligned}$$

What properties of numbers and operations justify from the green to orange line (from step 3 to step 4)?

Distributive Property
Addition
Associative Property
Commutative Property

142) Assistent #111291 "111291 - Commutative"

Here is one way you might prove that $40s + 64 + 6s$ is equivalent to $64 + 46s$

$$\begin{aligned}
 (1) & \quad 40s + 64 + 6s \\
 (2) & \quad = 64 + 40s + 6s \\
 (3) & \quad = 64 + (40 + 6) s \\
 (4) & \quad = 64 + 46s
 \end{aligned}$$

What properties of numbers and operations justify from green to orange step(from step 1 to step 2)?

Distributive Property

Addition

Associative Property

Commutative Property

143) Assistent #111292 "111292 - Commutative"

Here is one way you might prove that $30s + 45 + 9s$ is equivalent to $45 + 39s$

$$\begin{aligned}
 (1) & \quad 30s + 45 + 9s \\
 (2) & \quad = 45 + 30s + 9s \\
 (3) & \quad = 45 + (30 + 9) s \\
 (4) & \quad = 45 + 39s
 \end{aligned}$$

What properties of numbers and operations justify from green to orange step(from step 1 to step 2)?

Distributive Property

Addition

Associative Property

Commutative Property

144) Assistent #111293 "111293 - Commutative"

Here is one way you might prove that $35s + 35 + 5s$ is equivalent to $35 + 40s$

$$\begin{aligned}
 (1) & \quad 35s + 35 + 5s \\
 (2) & \quad = 35 + 35s + 5s \\
 (3) & \quad = 35 + (35 + 5) s \\
 (4) & \quad = 35 + 40s
 \end{aligned}$$

What properties of numbers and operations justify from green to orange step(from step 1 to step 2)?

Distributive Property

Addition

Associative Property

Commutative Property

145) Assistent #111294 "111294 - Commutative"

Here is one way you might prove that $45s + 40 + 5s$ is equivalent to $40 + 50s$

$$\begin{aligned}
 (1) & \quad 45s + 40 + 5s \\
 (2) & \quad = 40 + 45s + 5s \\
 (3) & \quad = 40 + (45 + 5) s \\
 (4) & \quad = 40 + 50s
 \end{aligned}$$

What properties of numbers and operations justify from green to orange step(from step 1 to step 2)?

Distributive Property

Addition

Associative Property

Commutative Property

146) Assistent #111295 "111295 - Commutative"

Here is one way you might prove that $30s + 36 + 9s$ is equivalent to $36 + 39s$

(1) $30s + 36 + 9s$

(2) $= 36 + 30s + 9s$

(3) $= 36 + (30 + 9) s$

(4) $= 36 + 39s$

What properties of numbers and operations justify from green to orange step(from step 1 to step 2)?

Distributive Property

Addition

Associative Property

Commutative Property

147) Assistent #111296 "111296 - Commutative"

Here is one way you might prove that $54s + 63 + 7s$ is equivalent to $63 + 61s$

(1) $54s + 63 + 7s$

(2) $= 63 + 54s + 7s$

(3) $= 63 + (54 + 7) s$

(4) $= 63 + 61s$

What properties of numbers and operations justify from green to orange step(from step 1 to step 2)?

Distributive Property

Addition

Associative Property

Commutative Property

148) Assistent #111297 "111297 - Commutative"

Here is one way you might prove that $72s + 45 + 5s$ is equivalent to $45 + 77s$

(1) $72s + 45 + 5s$

(2) $= 45 + 72s + 5s$

(3) $= 45 + (72 + 5) s$

(4) $= 45 + 77s$

What properties of numbers and operations justify from green to orange step(from step 1 to step 2)?

Distributive Property
Addition
Associative Property
Commutative Property

149) Assistent #111298 "111298 - Commutative"

Here is one way you might prove that $30s + 54 + 7s$ is equivalent to $54 + 37s$

$$\begin{aligned}(1) & 30s + 54 + 7s \\(2) & = 54 + 30s + 7s \\(3) & = 54 + (30 + 7) s \\(4) & = 54 + 37s\end{aligned}$$

What properties of numbers and operations justify from green to orange step(from step 1 to step 2)?

Distributive Property
Addition
Associative Property
Commutative Property

150) Assistent #111299 "111299 - Commutative"

Here is one way you might prove that $45s + 35 + 7s$ is equivalent to $35 + 52s$

$$\begin{aligned}(1) & 45s + 35 + 7s \\(2) & = 35 + 45s + 7s \\(3) & = 35 + (45 + 7) s \\(4) & = 35 + 52s\end{aligned}$$

What properties of numbers and operations justify from green to orange step(from step 1 to step 2)?

Distributive Property
Addition
Associative Property
Commutative Property

151) Assistent #111300 "111300 - Commutative"

Here is one way you might prove that $56s + 40 + 8s$ is equivalent to $40 + 64s$

$$\begin{aligned}(1) & 56s + 40 + 8s \\(2) & = 40 + 56s + 8s \\(3) & = 40 + (56 + 8) s \\(4) & = 40 + 64s\end{aligned}$$

What properties of numbers and operations justify from green to orange step(from step 1 to step 2)?

Distributive Property
Addition
Associative Property

Commutative Property

152) Assistent #111301 "111301 - Commutative"

Here is one way you might prove that $40s + 45 + 9s$ is equivalent to $45 + 49s$

$$\begin{aligned}(1) & 40s + 45 + 9s \\(2) & = 45 + 40s + 9s \\(3) & = 45 + (40 + 9) s \\(4) & = 45 + 49s\end{aligned}$$

What properties of numbers and operations justify from green to orange step(from step 1 to step 2)?

Distributive Property

Addition

Associative Property

Commutative Property

153) Assistent #111302 "111302 - Commutative"

Here is one way you might prove that $40s + 40 + 9s$ is equivalent to $40 + 49s$

$$\begin{aligned}(1) & 40s + 40 + 9s \\(2) & = 40 + 40s + 9s \\(3) & = 40 + (40 + 9) s \\(4) & = 40 + 49s\end{aligned}$$

What properties of numbers and operations justify from green to orange step(from step 1 to step 2)?

Distributive Property

Addition

Associative Property

Commutative Property

154) Assistent #111303 "111303 - Commutative"

Here is one way you might prove that $63s + 45 + 5s$ is equivalent to $45 + 68s$

$$\begin{aligned}(1) & 63s + 45 + 5s \\(2) & = 45 + 63s + 5s \\(3) & = 45 + (63 + 5) s \\(4) & = 45 + 68s\end{aligned}$$

What properties of numbers and operations justify from green to orange step(from step 1 to step 2)?

Distributive Property

Addition

Associative Property

Commutative Property

155) Assisment #111304 "111304 - Commutative"

Here is one way you might prove that $48s + 48 + 5s$ is equivalent to $48 + 53s$

$$\begin{aligned} (1) & 48s + 48 + 5s \\ (2) & = 48 + 48s + 5s \\ (3) & = 48 + (48 + 5) s \\ (4) & = 48 + 53s \end{aligned}$$

What properties of numbers and operations justify from green to orange step(from step 1 to step 2)?

Distributive Property

Addition

Associative Property

Commutative Property

156) Assisment #111305 "111305 - Commutative"

Here is one way you might prove that $64s + 72 + 7s$ is equivalent to $72 + 71s$

$$\begin{aligned} (1) & 64s + 72 + 7s \\ (2) & = 72 + 64s + 7s \\ (3) & = 72 + (64 + 7) s \\ (4) & = 72 + 71s \end{aligned}$$

What properties of numbers and operations justify from green to orange step(from step 1 to step 2)?

Distributive Property

Addition

Associative Property

Commutative Property

157) Assisment #111306 "111306 - Step 2-3 Dist"

Here is one way you might prove that $7(6s+8) + 6s$ is equivalent to $56 + 48s$

$$\begin{aligned} (1) & 7(6s+8) + 6s = 42s + 56 + 6s \\ (2) & = 56 + 42s + 6s \\ (3) & = 56 + (42 + 6) s \\ (4) & = 56 + 48s \end{aligned}$$

What properties of numbers and operations justify the step from the green line to the orange line (from step 2 to step 3)?

Distributive Property

Addition

Associative Property

Commutative Property

158) Assisment #111307 "111307 - Step 2-3 Dist"

Here is one way you might prove that $7(8s+7) + 6s$ is equivalent to $49 + 62s$

$$\begin{aligned} (1) & 7(8s+7) + 6s = 56s + 49 + 6s \\ (2) & = 49 + 56s + 6s \end{aligned}$$

$$(3) \quad = 49 + (56 + 6) s$$

$$(4) \quad = 49 + 62s$$

What properties of numbers and operations justify the step from the green line to the orange line (from step 2 to step 3)?

Distributive Property

Addition

Associative Property

Commutative Property

159) Assistent #111308 "111308 - Step 2-3 Dist"

Here is one way you might prove that $6(6s+5) + 7s$ is equivalent to $30 + 43s$

$$(1) \quad 6(6s+5) + 7s = 36s + 30 + 7s$$

$$(2) \quad = 30 + 36s + 7s$$

$$(3) \quad = 30 + (36 + 7) s$$

$$(4) \quad = 30 + 43s$$

What properties of numbers and operations justify the step from the green line to the orange line (from step 2 to step 3)?

Distributive Property

Addition

Associative Property

Commutative Property

160) Assistent #111309 "111309 - Step 2-3 Dist"

Here is one way you might prove that $5(9s+5) + 8s$ is equivalent to $25 + 53s$

$$(1) \quad 5(9s+5) + 8s = 45s + 25 + 8s$$

$$(2) \quad = 25 + 45s + 8s$$

$$(3) \quad = 25 + (45 + 8) s$$

$$(4) \quad = 25 + 53s$$

What properties of numbers and operations justify the step from the green line to the orange line (from step 2 to step 3)?

Distributive Property

Addition

Associative Property

Commutative Property

161) Assistent #111310 "111310 - Step 2-3 Dist"

Here is one way you might prove that $6(8s+9) + 6s$ is equivalent to $54 + 54s$

$$(1) \quad 6(8s+9) + 6s = 48s + 54 + 6s$$

$$(2) \quad = 54 + 48s + 6s$$

$$(3) \quad = 54 + (48 + 6) s$$

$$(4) \quad = 54 + 54s$$

What properties of numbers and operations justify the step from the green line to the orange line (from step 2 to step 3)?

Distributive Property
Addition
Associative Property
Commutative Property

162) Assistent #111311 "111311 - Step 2-3 Dist"

Here is one way you might prove that $9(8s+9) + 6s$ is equivalent to $81 + 78s$

$$\begin{aligned}(1) \quad & 9(8s+9) + 6s = 72s + 81 + 6s \\(2) \quad & = 81 + 72s + 6s \\(3) \quad & = 81 + (72 + 6) s \\(4) \quad & = 81 + 78s\end{aligned}$$

What properties of numbers and operations justify the step from the green line to the orange line (from step 2 to step 3)?

Distributive Property
Addition
Associative Property
Commutative Property

163) Assistent #111312 "111312 - Step 2-3 Dist"

Here is one way you might prove that $5(5s+6) + 7s$ is equivalent to $30 + 32s$

$$\begin{aligned}(1) \quad & 5(5s+6) + 7s = 25s + 30 + 7s \\(2) \quad & = 30 + 25s + 7s \\(3) \quad & = 30 + (25 + 7) s \\(4) \quad & = 30 + 32s\end{aligned}$$

What properties of numbers and operations justify the step from the green line to the orange line (from step 2 to step 3)?

Distributive Property
Addition
Associative Property
Commutative Property

164) Assistent #111313 "111313 - Step 2-3 Dist"

Here is one way you might prove that $7(9s+9) + 9s$ is equivalent to $63 + 72s$

$$\begin{aligned}(1) \quad & 7(9s+9) + 9s = 63s + 63 + 9s \\(2) \quad & = 63 + 63s + 9s \\(3) \quad & = 63 + (63 + 9) s \\(4) \quad & = 63 + 72s\end{aligned}$$

What properties of numbers and operations justify the step from the green line to the orange line (from step 2 to step 3)?

Distributive Property

Addition

Associative Property

Commutative Property

165) Assistent #111314 "111314 - Step 2-3 Dist"

Here is one way you might prove that $5(9s+8) + 9s$ is equivalent to $40 + 54s$

$$(1) 5(9s+8) + 9s = 45s + 40 + 9s$$

$$(2) \quad \quad \quad = 40 + 45s + 9s$$

$$(3) \quad \quad \quad = 40 + (45 + 9) s$$

$$(4) \quad \quad \quad = 40 + 54s$$

What properties of numbers and operations justify the step from the green line to the orange line (from step 2 to step 3)?

Distributive Property

Addition

Associative Property

Commutative Property

166) Assistent #111315 "111315 - Step 2-3 Dist"

Here is one way you might prove that $8(5s+8) + 8s$ is equivalent to $64 + 48s$

$$(1) 8(5s+8) + 8s = 40s + 64 + 8s$$

$$(2) \quad \quad \quad = 64 + 40s + 8s$$

$$(3) \quad \quad \quad = 64 + (40 + 8) s$$

$$(4) \quad \quad \quad = 64 + 48s$$

What properties of numbers and operations justify the step from the green line to the orange line (from step 2 to step 3)?

Distributive Property

Addition

Associative Property

Commutative Property

167) Assistent #111316 "111316 - Step 2-3 Dist"

Here is one way you might prove that $8(9s+9) + 6s$ is equivalent to $72 + 78s$

$$(1) 8(9s+9) + 6s = 72s + 72 + 6s$$

$$(2) \quad \quad \quad = 72 + 72s + 6s$$

$$(3) \quad \quad \quad = 72 + (72 + 6) s$$

$$(4) \quad \quad \quad = 72 + 78s$$

What properties of numbers and operations justify the step from the green line to the orange line (from step 2 to step 3)?

Distributive Property

Addition

Associative Property

Commutative Property

168) Assistent #111317 "111317 - Step 2-3 Dist"

Here is one way you might prove that $9(5s+6) + 6s$ is equivalent to $54 + 51s$

$$\begin{aligned}(1) \quad & 9(5s+6) + 6s = 45s + 54 + 6s \\(2) \quad & \quad \quad = 54 + 45s + 6s \\(3) \quad & \quad \quad = 54 + (45 + 6) s \\(4) \quad & \quad \quad = 54 + 51s\end{aligned}$$

What properties of numbers and operations justify the step from the green line to the orange line (from step 2 to step 3)?

- Distributive Property
- Addition
- Associative Property
- Commutative Property

169) Assistent #111318 "111318 - Step 2-3 Dist"

Here is one way you might prove that $6(5s+6) + 8s$ is equivalent to $36 + 38s$

$$\begin{aligned}(1) \quad & 6(5s+6) + 8s = 30s + 36 + 8s \\(2) \quad & \quad \quad = 36 + 30s + 8s \\(3) \quad & \quad \quad = 36 + (30 + 8) s \\(4) \quad & \quad \quad = 36 + 38s\end{aligned}$$

What properties of numbers and operations justify the step from the green line to the orange line (from step 2 to step 3)?

- Distributive Property
- Addition
- Associative Property
- Commutative Property

170) Assistent #111319 "111319 - Step 2-3 Dist"

Here is one way you might prove that $6(6s+7) + 6s$ is equivalent to $42 + 42s$

$$\begin{aligned}(1) \quad & 6(6s+7) + 6s = 36s + 42 + 6s \\(2) \quad & \quad \quad = 42 + 36s + 6s \\(3) \quad & \quad \quad = 42 + (36 + 6) s \\(4) \quad & \quad \quad = 42 + 42s\end{aligned}$$

What properties of numbers and operations justify the step from the green line to the orange line (from step 2 to step 3)?

- Distributive Property
- Addition
- Associative Property
- Commutative Property

171) Assistent #111320 "111320 - Step 2-3 Dist"

Here is one way you might prove that $9(8s+7) + 7s$ is equivalent to $63 + 79s$

$$\begin{aligned}
 (1) \quad & 9(8s+7) + 7s = 72s + 63 + 7s \\
 (2) \quad & = 63 + 72s + 7s \\
 (3) \quad & = 63 + (72 + 7) s \\
 (4) \quad & = 63 + 79s
 \end{aligned}$$

What properties of numbers and operations justify the step from the green line to the orange line (from step 2 to step 3)?

- Distributive Property
- Addition
- Associative Property
- Commutative Property

172) Assistent #111321 "111321 - commutative, step 1-5"

Here is one way you might prove that $20 + 8(8x + 8) + 18x$ is equivalent to $82x + 84$

$$\begin{aligned}
 1. \quad & 8(8x + 8) + 20 + 18x \\
 2. \quad & = 64x + 64 + 20 + 18x \\
 3. \quad & = 64x + 18x + 64 + 20 \\
 4. \quad & = (64 + 18)x + 64 + 20 \\
 5. \quad & = 82x + 84
 \end{aligned}$$

What properties of numbers and operations justify the step from the green line to the orange line (from step 2 to step 3)?

- Distributive Property
- Addition
- Associative Property
- Commutative Property

173) Assistent #111322 "111322 - commutative, step 1-5"

Here is one way you might prove that $24 + 9(6x + 5) + 17x$ is equivalent to $71x + 69$

$$\begin{aligned}
 1. \quad & 9(6x + 5) + 24 + 17x \\
 2. \quad & = 54x + 45 + 24 + 17x \\
 3. \quad & = 54x + 17x + 45 + 24 \\
 4. \quad & = (54 + 17)x + 45 + 24 \\
 5. \quad & = 71x + 69
 \end{aligned}$$

What properties of numbers and operations justify the step from the green line to the orange line (from step 2 to step 3)?

- Distributive Property
- Addition
- Associative Property
- Commutative Property

174) Assistent #111323 "111323 - commutative, step 1-5"

Here is one way you might prove that $22 + 6(7x + 6) + 16x$ is equivalent to $58x + 58$

$$\begin{aligned}
 1. \quad & 6(7x + 6) + 22 + 16x \\
 2. \quad & = 42x + 36 + 22 + 16x
 \end{aligned}$$

$$\begin{aligned}
3. & \quad = 42x + 16x + 36 + 22 \\
4. & \quad = (42 + 16)x + 36 + 22 \\
5. & \quad = 58x + 58
\end{aligned}$$

What properties of numbers and operations justify the step from the green line to the orange line (from step 2 to step 3)?

- Distributive Property
- Addition
- Associative Property
- Commutative Property

175) Assistent #111324 "111324 - commutative, step 1-5"

Here is one way you might prove that $21 + 8(6x + 5) + 16x$ is equivalent to $64x + 61$

$$\begin{aligned}
1. & \quad 8(6x + 5) + 21 + 16x \\
2. & \quad = 48x + 40 + 21 + 16x \\
3. & \quad = 48x + 16x + 40 + 21 \\
4. & \quad = (48 + 16)x + 40 + 21 \\
5. & \quad = 64x + 61
\end{aligned}$$

What properties of numbers and operations justify the step from the green line to the orange line (from step 2 to step 3)?

- Distributive Property
- Addition
- Associative Property
- Commutative Property

176) Assistent #111325 "111325 - commutative, step 1-5"

Here is one way you might prove that $20 + 6(6x + 5) + 15x$ is equivalent to $51x + 50$

$$\begin{aligned}
1. & \quad 6(6x + 5) + 20 + 15x \\
2. & \quad = 36x + 30 + 20 + 15x \\
3. & \quad = 36x + 15x + 30 + 20 \\
4. & \quad = (36 + 15)x + 30 + 20 \\
5. & \quad = 51x + 50
\end{aligned}$$

What properties of numbers and operations justify the step from the green line to the orange line (from step 2 to step 3)?

- Distributive Property
- Addition
- Associative Property
- Commutative Property

177) Assistent #111326 "111326 - commutative, step 1-5"

Here is one way you might prove that $21 + 8(6x + 9) + 15x$ is equivalent to $63x + 93$

$$\begin{aligned}
1. & \quad 8(6x + 9) + 21 + 15x \\
2. & \quad = 48x + 72 + 21 + 15x \\
3. & \quad = 48x + 15x + 72 + 21
\end{aligned}$$

$$4. \quad = (48 + 15)x + 72 + 21$$

$$5. \quad = 63x + 93$$

What properties of numbers and operations justify the step from the green line to the orange line (from step 2 to step 3)?

Distributive Property

Addition

Associative Property

Commutative Property

178) Assistent #111327 "111327 - commutative, step 1-5"

Here is one way you might prove that $24 + 8(8x + 9) + 18x$ is equivalent to $82x + 96$

$$1. \quad 8(8x + 9) + 24 + 18x$$

$$2. \quad = 64x + 72 + 24 + 18x$$

$$3. \quad = 64x + 18x + 72 + 24$$

$$4. \quad = (64 + 18)x + 72 + 24$$

$$5. \quad = 82x + 96$$

What properties of numbers and operations justify the step from the green line to the orange line (from step 2 to step 3)?

Distributive Property

Addition

Associative Property

Commutative Property

179) Assistent #111328 "111328 - commutative, step 1-5"

Here is one way you might prove that $20 + 6(8x + 8) + 19x$ is equivalent to $67x + 68$

$$1. \quad 6(8x + 8) + 20 + 19x$$

$$2. \quad = 48x + 48 + 20 + 19x$$

$$3. \quad = 48x + 19x + 48 + 20$$

$$4. \quad = (48 + 19)x + 48 + 20$$

$$5. \quad = 67x + 68$$

What properties of numbers and operations justify the step from the green line to the orange line (from step 2 to step 3)?

Distributive Property

Addition

Associative Property

Commutative Property

180) Assistent #111329 "111329 - commutative, step 1-5"

Here is one way you might prove that $22 + 8(8x + 8) + 15x$ is equivalent to $79x + 86$

$$1. \quad 8(8x + 8) + 22 + 15x$$

$$2. \quad = 64x + 64 + 22 + 15x$$

$$3. \quad = 64x + 15x + 64 + 22$$

$$4. \quad = (64 + 15)x + 64 + 22$$

5. $= 79x + 86$

What properties of numbers and operations justify the step from the green line to the orange line (from step 2 to step 3)?

Distributive Property

Addition

Associative Property

Commutative Property

181) Assistent #111330 "111330 - commutative, step 1-5"

Here is one way you might prove that $24 + 8(9x + 9) + 17x$ is equivalent to $89x + 96$

1. $8(9x + 9) + 24 + 17x$

2. $= 72x + 72 + 24 + 17x$

3. $= 72x + 17x + 72 + 24$

4. $= (72 + 17)x + 72 + 24$

5. $= 89x + 96$

What properties of numbers and operations justify the step from the green line to the orange line (from step 2 to step 3)?

Distributive Property

Addition

Associative Property

Commutative Property

182) Assistent #111331 "111331 - commutative, step 1-5"

Here is one way you might prove that $23 + 7(5x + 5) + 18x$ is equivalent to $53x + 58$

1. $7(5x + 5) + 23 + 18x$

2. $= 35x + 35 + 23 + 18x$

3. $= 35x + 18x + 35 + 23$

4. $= (35 + 18)x + 35 + 23$

5. $= 53x + 58$

What properties of numbers and operations justify the step from the green line to the orange line (from step 2 to step 3)?

Distributive Property

Addition

Associative Property

Commutative Property

183) Assistent #111332 "111332 - commutative, step 1-5"

Here is one way you might prove that $24 + 6(9x + 7) + 16x$ is equivalent to $70x + 66$

1. $6(9x + 7) + 24 + 16x$

2. $= 54x + 42 + 24 + 16x$

3. $= 54x + 16x + 42 + 24$

4. $= (54 + 16)x + 42 + 24$

5. $= 70x + 66$

What properties of numbers and operations justify the step from the green line to the orange line (from step 2 to step 3)?

- Distributive Property
- Addition
- Associative Property
- Commutative Property

184) Assistent #111333 "111333 - commutative, step 1-5"

Here is one way you might prove that $20 + 5(7x + 9) + 16x$ is equivalent to $51x + 65$

1. $5(7x + 9) + 20 + 16x$
2. $= 35x + 45 + 20 + 16x$
3. $= 35x + 16x + 45 + 20$
4. $= (35 + 16)x + 45 + 20$
5. $= 51x + 65$

What properties of numbers and operations justify the step from the green line to the orange line (from step 2 to step 3)?

- Distributive Property
- Addition
- Associative Property
- Commutative Property

185) Assistent #111334 "111334 - commutative, step 1-5"

Here is one way you might prove that $22 + 5(6x + 9) + 19x$ is equivalent to $49x + 67$

1. $5(6x + 9) + 22 + 19x$
2. $= 30x + 45 + 22 + 19x$
3. $= 30x + 19x + 45 + 22$
4. $= (30 + 19)x + 45 + 22$
5. $= 49x + 67$

What properties of numbers and operations justify the step from the green line to the orange line (from step 2 to step 3)?

- Distributive Property
- Addition
- Associative Property
- Commutative Property

186) Assistent #111335 "111335 - commutative, step 1-5"

Here is one way you might prove that $22 + 6(9x + 9) + 19x$ is equivalent to $73x + 76$

1. $6(9x + 9) + 22 + 19x$
2. $= 54x + 54 + 22 + 19x$
3. $= 54x + 19x + 54 + 22$
4. $= (54 + 19)x + 54 + 22$
5. $= 73x + 76$

What properties of numbers and operations justify the step from the green line to the

orange line (from step 2 to step 3)?

Distributive Property
Addition
Associative Property
Commutative Property

187) Assistent #111336 "111336 - dist, step 1-5"

Here is one way you might prove that $22 + 19x + 6(6x + 8)$ is equivalent to $70 + 55x$

1. $22 + 19x + 6(6x + 8)$
2. $= 22 + 19x + 36x + 48$
3. $= 48 + 22 + 36x + 19x$
4. $= 48 + 22 + (36 + 19)x$
5. $= 70 + 55x$

What properties of numbers and operations justify the step from the green line to the orange line (from step 3 to step 4)?

Distributive Property
Addition
Associative Property
Commutative Property

188) Assistent #111337 "111337 - dist, step 1-5"

Here is one way you might prove that $23 + 16x + 8(8x + 5)$ is equivalent to $63 + 80x$

1. $23 + 16x + 8(8x + 5)$
2. $= 23 + 16x + 64x + 40$
3. $= 40 + 23 + 64x + 16x$
4. $= 40 + 23 + (64 + 16)x$
5. $= 63 + 80x$

What properties of numbers and operations justify the step from the green line to the orange line (from step 3 to step 4)?

Distributive Property
Addition
Associative Property
Commutative Property

189) Assistent #111338 "111338 - dist, step 1-5"

Here is one way you might prove that $24 + 19x + 8(8x + 7)$ is equivalent to $80 + 83x$

1. $24 + 19x + 8(8x + 7)$
2. $= 24 + 19x + 64x + 56$
3. $= 56 + 24 + 64x + 19x$
4. $= 56 + 24 + (64 + 19)x$
5. $= 80 + 83x$

What properties of numbers and operations justify the step from the green line to the orange line (from step 3 to step 4)?

Distributive Property
Addition
Associative Property
Commutative Property

190) Assistent #111339 "111339 - dist, step 1-5"

Here is one way you might prove that $21 + 15x + 5(9x + 5)$ is equivalent to $46 + 60x$

1. $21 + 15x + 5(9x + 5)$
2. $= 21 + 15x + 45x + 25$
3. $= 25 + 21 + 45x + 15x$
4. $= 25 + 21 + (45 + 15)x$
5. $= 46 + 60x$

What properties of numbers and operations justify the step from the green line to the orange line (from step 3 to step 4)?

Distributive Property
Addition
Associative Property
Commutative Property

191) Assistent #111340 "111340 - dist, step 1-5"

Here is one way you might prove that $20 + 18x + 7(9x + 5)$ is equivalent to $55 + 81x$

1. $20 + 18x + 7(9x + 5)$
2. $= 20 + 18x + 63x + 35$
3. $= 35 + 20 + 63x + 18x$
4. $= 35 + 20 + (63 + 18)x$
5. $= 55 + 81x$

What properties of numbers and operations justify the step from the green line to the orange line (from step 3 to step 4)?

Distributive Property
Addition
Associative Property
Commutative Property

192) Assistent #111341 "111341 - dist, step 1-5"

Here is one way you might prove that $23 + 16x + 5(7x + 9)$ is equivalent to $68 + 51x$

1. $23 + 16x + 5(7x + 9)$
2. $= 23 + 16x + 35x + 45$
3. $= 45 + 23 + 35x + 16x$
4. $= 45 + 23 + (35 + 16)x$
5. $= 68 + 51x$

What properties of numbers and operations justify the step from the green line to the orange line (from step 3 to step 4)?

Distributive Property
Addition
Associative Property
Commutative Property

193) Assistent #111342 "111342 - dist, step 1-5"

Here is one way you might prove that $21 + 16x + 5(9x + 6)$ is equivalent to $51 + 61x$

1. $21 + 16x + 5(9x + 6)$
2. $= 21 + 16x + 45x + 30$
3. $= 30 + 21 + 45x + 16x$
4. $= 30 + 21 + (45 + 16)x$
5. $= 51 + 61x$

What properties of numbers and operations justify the step from the green line to the orange line (from step 3 to step 4)?

Distributive Property
Addition
Associative Property
Commutative Property

194) Assistent #111343 "111343 - dist, step 1-5"

Here is one way you might prove that $21 + 16x + 5(9x + 9)$ is equivalent to $66 + 61x$

1. $21 + 16x + 5(9x + 9)$
2. $= 21 + 16x + 45x + 45$
3. $= 45 + 21 + 45x + 16x$
4. $= 45 + 21 + (45 + 16)x$
5. $= 66 + 61x$

What properties of numbers and operations justify the step from the green line to the orange line (from step 3 to step 4)?

Distributive Property
Addition
Associative Property
Commutative Property

195) Assistent #111344 "111344 - dist, step 1-5"

Here is one way you might prove that $20 + 15x + 7(7x + 9)$ is equivalent to $83 + 64x$

1. $20 + 15x + 7(7x + 9)$
2. $= 20 + 15x + 49x + 63$
3. $= 63 + 20 + 49x + 15x$
4. $= 63 + 20 + (49 + 15)x$
5. $= 83 + 64x$

What properties of numbers and operations justify the step from the green line to the orange line (from step 3 to step 4)?

Distributive Property
Addition
Associative Property
Commutative Property

196) Assistent #111345 "111345 - dist, step 1-5"

Here is one way you might prove that $22 + 16x + 5(9x + 8)$ is equivalent to $62 + 61x$

1. $22 + 16x + 5(9x + 8)$
2. $= 22 + 16x + 45x + 40$
3. $= 40 + 22 + 45x + 16x$
4. $= 40 + 22 + (45 + 16)x$
5. $= 62 + 61x$

What properties of numbers and operations justify the step from the green line to the orange line (from step 3 to step 4)?

Distributive Property
Addition
Associative Property
Commutative Property

197) Assistent #111346 "111346 - dist, step 1-5"

Here is one way you might prove that $20 + 17x + 9(7x + 5)$ is equivalent to $65 + 80x$

1. $20 + 17x + 9(7x + 5)$
2. $= 20 + 17x + 63x + 45$
3. $= 45 + 20 + 63x + 17x$
4. $= 45 + 20 + (63 + 17)x$
5. $= 65 + 80x$

What properties of numbers and operations justify the step from the green line to the orange line (from step 3 to step 4)?

Distributive Property
Addition
Associative Property
Commutative Property

198) Assistent #111347 "111347 - dist, step 1-5"

Here is one way you might prove that $23 + 17x + 7(7x + 7)$ is equivalent to $72 + 66x$

1. $23 + 17x + 7(7x + 7)$
2. $= 23 + 17x + 49x + 49$
3. $= 49 + 23 + 49x + 17x$
4. $= 49 + 23 + (49 + 17)x$
5. $= 72 + 66x$

What properties of numbers and operations justify the step from the green line to the orange line (from step 3 to step 4)?

Distributive Property

Addition

Associative Property

Commutative Property

199) Assistent #111348 "111348 - dist, step 1-5"

Here is one way you might prove that $20 + 16x + 7(6x + 9)$ is equivalent to $83 + 58x$

1. $20 + 16x + 7(6x + 9)$
2. $= 20 + 16x + 42x + 63$
3. $= 63 + 20 + 42x + 16x$
4. $= 63 + 20 + (42 + 16)x$
5. $= 83 + 58x$

What properties of numbers and operations justify the step from the green line to the orange line (from step 3 to step 4)?

Distributive Property

Addition

Associative Property

Commutative Property

200) Assistent #111349 "111349 - dist, step 1-5"

Here is one way you might prove that $20 + 15x + 8(6x + 9)$ is equivalent to $92 + 63x$

1. $20 + 15x + 8(6x + 9)$
2. $= 20 + 15x + 48x + 72$
3. $= 72 + 20 + 48x + 15x$
4. $= 72 + 20 + (48 + 15)x$
5. $= 92 + 63x$

What properties of numbers and operations justify the step from the green line to the orange line (from step 3 to step 4)?

Distributive Property

Addition

Associative Property

Commutative Property

201) Assistent #111350 "111350 - dist, step 1-5"

Here is one way you might prove that $21 + 18x + 7(6x + 5)$ is equivalent to $56 + 60x$

1. $21 + 18x + 7(6x + 5)$
2. $= 21 + 18x + 42x + 35$
3. $= 35 + 21 + 42x + 18x$
4. $= 35 + 21 + (42 + 18)x$
5. $= 56 + 60x$

What properties of numbers and operations justify the step from the green line to the orange line (from step 3 to step 4)?

Distributive Property

Addition

Associative Property
Commutative Property

202) Assistent #111351 "111351 - addition 4 elements"

Here is one way you might prove that $63 + 20 + 81x + 18x$ is equivalent to $83 + 99x$

1. $63 + 20 + 81x + 18x$
2. $ = 63 + 20 + (81 + 18)x$
3. $ = 83 + 99x$

What properties of numbers and operations justify the step from the green line to the orange line (from step 2 to step 3)?

Distributive Property
Addition
Associative Property
Commutative Property

203) Assistent #111352 "111352 - addition 4 elements"

Here is one way you might prove that $35 + 21 + 35x + 15x$ is equivalent to $56 + 50x$

1. $35 + 21 + 35x + 15x$
2. $ = 35 + 21 + (35 + 15)x$
3. $ = 56 + 50x$

What properties of numbers and operations justify the step from the green line to the orange line (from step 2 to step 3)?

Distributive Property
Addition
Associative Property
Commutative Property

204) Assistent #111353 "111353 - addition 4 elements"

Here is one way you might prove that $35 + 21 + 40x + 15x$ is equivalent to $56 + 55x$

1. $35 + 21 + 40x + 15x$
2. $ = 35 + 21 + (40 + 15)x$
3. $ = 56 + 55x$

What properties of numbers and operations justify the step from the green line to the orange line (from step 2 to step 3)?

Distributive Property
Addition
Associative Property
Commutative Property

205) Assistent #111354 "111354 - addition 4 elements"

Here is one way you might prove that $54 + 24 + 30x + 19x$ is equivalent to $78 + 49x$

$$\begin{aligned}
 1. & 54 + 24 + 30x + 19x \\
 2. & \qquad \qquad \qquad = 54 + 24 + (30 + 19)x \\
 3. & \qquad \qquad \qquad = 78 + 49x
 \end{aligned}$$

What properties of numbers and operations justify the step from the green line to the orange line (from step 2 to step 3)?

- Distributive Property
- Addition
- Associative Property
- Commutative Property

206) Assistent #111355 "111355 - addition 4 elements"

Here is one way you might prove that $30 + 20 + 30x + 18x$ is equivalent to $50 + 48x$

$$\begin{aligned}
 1. & 30 + 20 + 30x + 18x \\
 2. & \qquad \qquad \qquad = 30 + 20 + (30 + 18)x \\
 3. & \qquad \qquad \qquad = 50 + 48x
 \end{aligned}$$

What properties of numbers and operations justify the step from the green line to the orange line (from step 2 to step 3)?

- Distributive Property
- Addition
- Associative Property
- Commutative Property

207) Assistent #111356 "111356 - addition 4 elements"

Here is one way you might prove that $64 + 22 + 48x + 18x$ is equivalent to $86 + 66x$

$$\begin{aligned}
 1. & 64 + 22 + 48x + 18x \\
 2. & \qquad \qquad \qquad = 64 + 22 + (48 + 18)x \\
 3. & \qquad \qquad \qquad = 86 + 66x
 \end{aligned}$$

What properties of numbers and operations justify the step from the green line to the orange line (from step 2 to step 3)?

- Distributive Property
- Addition
- Associative Property
- Commutative Property

208) Assistent #111357 "111357 - addition 4 elements"

Here is one way you might prove that $40 + 22 + 35x + 19x$ is equivalent to $62 + 54x$

$$\begin{aligned}
 1. & 40 + 22 + 35x + 19x \\
 2. & \qquad \qquad \qquad = 40 + 22 + (35 + 19)x \\
 3. & \qquad \qquad \qquad = 62 + 54x
 \end{aligned}$$

What properties of numbers and operations justify the step from the green line to the orange line (from step 2 to step 3)?

Distributive Property
Addition
Associative Property
Commutative Property

209) Assistent #111358 "111358 - addition 4 elements"

Here is one way you might prove that $63 + 21 + 56x + 15x$ is equivalent to $84 + 71x$

1. $63 + 21 + 56x + 15x$
2. $= 63 + 21 + (56 + 15)x$
3. $= 84 + 71x$

What properties of numbers and operations justify the step from the green line to the orange line (from step 2 to step 3)?

Distributive Property
Addition
Associative Property
Commutative Property

210) Assistent #111359 "111359 - addition 4 elements"

Here is one way you might prove that $48 + 24 + 48x + 17x$ is equivalent to $72 + 65x$

1. $48 + 24 + 48x + 17x$
2. $= 48 + 24 + (48 + 17)x$
3. $= 72 + 65x$

What properties of numbers and operations justify the step from the green line to the orange line (from step 2 to step 3)?

Distributive Property
Addition
Associative Property
Commutative Property

211) Assistent #111360 "111360 - addition 4 elements"

Here is one way you might prove that $72 + 21 + 64x + 19x$ is equivalent to $93 + 83x$

1. $72 + 21 + 64x + 19x$
2. $= 72 + 21 + (64 + 19)x$
3. $= 93 + 83x$

What properties of numbers and operations justify the step from the green line to the orange line (from step 2 to step 3)?

Distributive Property
Addition
Associative Property
Commutative Property

212) Assistent #111361 "111361 - addition 4 elements"

Here is one way you might prove that $72 + 24 + 56x + 18x$ is equivalent to $96 + 74x$

1. $72 + 24 + 56x + 18x$

2. $= 72 + 24 + (56 + 18)x$

3. $= 96 + 74x$

What properties of numbers and operations justify the step from the green line to the orange line (from step 2 to step 3)?

Distributive Property

Addition

Associative Property

Commutative Property

213) Assistent #111362 "111362 - addition 4 elements"

Here is one way you might prove that $54 + 21 + 54x + 16x$ is equivalent to $75 + 70x$

1. $54 + 21 + 54x + 16x$

2. $= 54 + 21 + (54 + 16)x$

3. $= 75 + 70x$

What properties of numbers and operations justify the step from the green line to the orange line (from step 2 to step 3)?

Distributive Property

Addition

Associative Property

Commutative Property

214) Assistent #111363 "111363 - addition 4 elements"

Here is one way you might prove that $49 + 20 + 63x + 18x$ is equivalent to $69 + 81x$

1. $49 + 20 + 63x + 18x$

2. $= 49 + 20 + (63 + 18)x$

3. $= 69 + 81x$

What properties of numbers and operations justify the step from the green line to the orange line (from step 2 to step 3)?

Distributive Property

Addition

Associative Property

Commutative Property

215) Assistent #111364 "111364 - addition 4 elements"

Here is one way you might prove that $42 + 20 + 63x + 17x$ is equivalent to $62 + 80x$

1. $42 + 20 + 63x + 17x$

2. $= 42 + 20 + (63 + 17)x$

3. $= 62 + 80x$

What properties of numbers and operations justify the step from the green line to the

orange line (from step 2 to step 3)?

- Distributive Property
 - Addition
 - Associative Property
 - Commutative Property
-

216) Assistent #111365 "111365 - addition 4 elements"

Here is one way you might prove that $25 + 24 + 35x + 15x$ is equivalent to $49 + 50x$

1. $25 + 24 + 35x + 15x$

2. $= 25 + 24 + (35 + 15)x$

3. $= 49 + 50x$

What properties of numbers and operations justify the step from the green line to the orange line (from step 2 to step 3)?

- Distributive Property
 - Addition
 - Associative Property
 - Commutative Property
-

Problem Set 6876 "Converting Decimals to Fractions - LEVEL 1 SKILL BUILDING" id:[6876]

1) Assistent #47275 "47275 - Converting Decimals to Fractions"

Convert 0.12 into a **fraction**.

2) Assistent #47276 "47276 - Converting Decimals to Fractions"

Convert 0.15 into a **fraction**.

3) Assistent #47277 "47277 - Converting Decimals to Fractions"

Convert 0.73 into a **fraction**.

4) Assistent #47278 "47278 - Converting Decimals to Fractions"

Convert 0.72 into a **fraction**.

5) Assistent #47279 "47279 - Converting Decimals to Fractions"

Convert 0.8 into a **fraction**.

6) Assistent #47280 "47280 - Converting Decimals to Fractions"

Convert 0.62 into a **fraction**.

7) Assistent #47281 "47281 - Converting Decimals to Fractions"

Convert 0.75 into a **fraction**.

8) Assistent #47282 "47282 - Converting Decimals to Fractions"

Convert 0.89 into a **fraction**.

9) Assistent #47283 "47283 - Converting Decimals to Fractions"

Convert 0.35 into a **fraction**.

10) Assistent #47284 "47284 - Converting Decimals to Fractions"

Convert 0.84 into a **fraction**.

11) Assistent #47285 "47285 - Converting Decimals to Fractions"

Convert 0.77 into a **fraction**.

12) Assistent #47286 "47286 - Converting Decimals to Fractions"

Convert 0.27 into a **fraction**.

13) Assistent #47287 "47287 - Converting Decimals to Fractions"

Convert 0.2 into a **fraction**.

14) Assistent #47288 "47288 - Converting Decimals to Fractions"

Convert 0.49 into a **fraction**.

15) Assistent #47289 "47289 - Converting Decimals to Fractions"

Convert 0.04 into a **fraction**.

16) Assistent #47290 "47290 - Converting Decimals to Fractions"

Convert 0.89 into a **fraction**.

17) Assistent #47291 "47291 - Converting Decimals to Fractions"

Convert 0.73 into a **fraction**.

18) Assistent #47292 "47292 - Converting Decimals to Fractions"

Convert 0.22 into a **fraction**.

19) Assistent #47293 "47293 - Converting Decimals to Fractions"

Convert 0.58 into a **fraction**.

20) Assistent #47294 "47294 - Converting Decimals to Fractions"

21) Assistent #47295 "47295 - Converting Decimals to Fractions"

Convert 0.94 into a **fraction**.

22) Assistent #47296 "47296 - Converting Decimals to Fractions"

Convert 0.43 into a **fraction**.

23) Assistent #47297 "47297 - Converting Decimals to Fractions"

Convert 0.35 into a **fraction**.

24) Assistent #47298 "47298 - Converting Decimals to Fractions"

Convert 0.26 into a **fraction**.

25) Assistent #47299 "47299 - Converting Decimals to Fractions"

Convert 0.41 into a **fraction**.

26) Assistent #47300 "47300 - Converting Decimals to Fractions"

Convert 0.34 into a **fraction**.

28) Assistent #47302 "47302 - Converting Decimals to Fractions"

Convert 0.57 into a **fraction**.

29) Assistent #47303 "47303 - Converting Decimals to Fractions"

Convert 0.39 into a **fraction**.

30) Assistent #47304 "47304 - Converting Decimals to Fractions"

Convert 0.35 into a **fraction**.

31) Assistent #47305 "47305 - Converting Decimals to Fractions"

Convert 0.52 into a **fraction**.

32) Assistent #47306 "47306 - Converting Decimals to Fractions"

Convert 0.44 into a **fraction**.

33) Assistent #47307 "47307 - Converting Decimals to Fractions"

Convert 0.23 into a **fraction**.

35) Assistent #47309 "47309 - Converting Decimals to Fractions"

Convert 0.49 into a **fraction**.

36) Assistent #47310 "47310 - Converting Decimals to Fractions"

Convert 0.08 into a **fraction**.

37) Assistent #47311 "47311 - Converting Decimals to Fractions"

Convert 0.74 into a **fraction**.

38) Assistent #47312 "47312 - Converting Decimals to Fractions"

Convert 0.75 into a **fraction**.

39) Assistent #47313 "47313 - Converting Decimals to Fractions"

Convert 0.09 into a **fraction**.

40) Assistent #47314 "47314 - Converting Decimals to Fractions"

Convert 0.13 into a **fraction**.

42) Assistent #47316 "47316 - Converting Decimals to Fractions"

Convert 0.33 into a **fraction**.

43) Assistent #47317 "47317 - Converting Decimals to Fractions"

Convert 0.76 into a **fraction**.

44) Assistent #47318 "47318 - Converting Decimals to Fractions"

Convert 0.19 into a **fraction**.

45) Assistent #47319 "47319 - Converting Decimals to Fractions"

Convert 0.56 into a **fraction**.

46) Assistent #47320 "47320 - Converting Decimals to Fractions"

Convert 0.88 into a **fraction**.

47) Assistent #47321 "47321 - Converting Decimals to Fractions"

Convert 0.21 into a **fraction**.

48) Assistent #47322 "47322 - Converting Decimals to Fractions"

Convert 0.26 into a **fraction**.

49) Assistent #47323 "47323 - Converting Decimals to Fractions"

Convert 0.21 into a **fraction**.

50) Assistent #47324 "47324 - Converting Decimals to Fractions"

Convert 0.39 into a **fraction**.

51) Assistent #47325 "47325 - Converting Decimals to Fractions - 7th Grade"

Convert 0.25 into a **fraction**. You must simplify your answer to lowest terms.

52) Assistent #47326 "47326 - Converting Decimals to Fractions - 7th Grade"

Convert 0.75 into a **fraction**. You must simplify your answer to lowest terms.

53) Assistent #47327 "47327 - Converting Decimals to Fractions - 7th Grade"

Convert 0.1 into a **fraction**. You must simplify your answer to lowest terms.

54) Assistent #47328 "47328 - Converting Decimals to Fractions - 7th Grade"

Convert 0.2 into a **fraction**. You must simplify your answer to lowest terms.

55) Assistent #47329 "47329 - Converting Decimals to Fractions - 7th Grade"

Convert 0.3 into a **fraction**. You must simplify your answer to lowest terms.

56) Assistent #47330 "47330 - Converting Decimals to Fractions - 7th Grade"

Convert 0.4 into a **fraction**. You must simplify your answer to lowest terms.

57) Assistent #47331 "47331 - Converting Decimals to Fractions - 7th Grade"

Convert 0.5 into a **fraction**. You must simplify your answer to lowest terms.

58) Assistent #47332 "47332 - Converting Decimals to Fractions - 7th Grade"

Convert 0.6 into a **fraction**. You must simplify your answer to lowest terms.

59) Assistent #47333 "47333 - Converting Decimals to Fractions - 7th Grade"

Convert 0.7 into a **fraction**. You must simplify your answer to lowest terms.

60) Assistent #47334 "47334 - Converting Decimals to Fractions - 7th Grade"

Convert 0.8 into a **fraction**. You must simplify your answer to lowest terms.

61) Assistent #47335 "47335 - Converting Decimals to Fractions - 7th Grade"

Convert 0.25 into a **fraction**. You must simplify your answer to lowest terms.

62) Assistent #47336 "47336 - Converting Decimals to Fractions - 7th Grade"

Convert 0.75 into a **fraction**. You must simplify your answer to lowest terms.

63) Assistent #47337 "47337 - Converting Decimals to Fractions - 7th Grade"

Convert 0.1 into a **fraction**. You must simplify your answer to lowest terms.

64) Assistent #47338 "47338 - Converting Decimals to Fractions - 7th Grade"
Convert 0.2 into a **fraction**. You must simplify your answer to lowest terms.

65) Assistent #47339 "47339 - Converting Decimals to Fractions - 7th Grade"
Convert 0.3 into a **fraction**. You must simplify your answer to lowest terms.

66) Assistent #47340 "47340 - Converting Decimals to Fractions - 7th Grade"
Convert 0.4 into a **fraction**. You must simplify your answer to lowest terms.

67) Assistent #47341 "47341 - Converting Decimals to Fractions - 7th Grade"
Convert 0.5 into a **fraction**. You must simplify your answer to lowest terms.

68) Assistent #47342 "47342 - Converting Decimals to Fractions - 7th Grade"
Convert 0.6 into a **fraction**. You must simplify your answer to lowest terms.

69) Assistent #47343 "47343 - Converting Decimals to Fractions - 7th Grade"
Convert 0.7 into a **fraction**. You must simplify your answer to lowest terms.

70) Assistent #47344 "47344 - Converting Decimals to Fractions - 7th Grade"
Convert 0.8 into a **fraction**. You must simplify your answer to lowest terms.

71) Assistent #47345 "47345 - Converting Decimals to Fractions - 7th Grade"
Convert 0.25 into a **fraction**. You must simplify your answer to lowest terms.

72) Assistent #47346 "47346 - Converting Decimals to Fractions - 7th Grade"

Convert 0.75 into a **fraction**. You must simplify your answer to lowest terms.

73) Assistent #47347 "47347 - Converting Decimals to Fractions - 7th Grade"

Convert 0.1 into a **fraction**. You must simplify your answer to lowest terms.

74) Assistent #47348 "47348 - Converting Decimals to Fractions - 7th Grade"

Convert 0.2 into a **fraction**. You must simplify your answer to lowest terms.

75) Assistent #47349 "47349 - Converting Decimals to Fractions - 7th Grade"

Convert 0.3 into a **fraction**. You must simplify your answer to lowest terms.

76) Assistent #47350 "47350 - Converting Decimals to Fractions - 7th Grade"

Convert 0.4 into a **fraction**. You must simplify your answer to lowest terms.

77) Assistent #47351 "47351 - Converting Decimals to Fractions - 7th Grade"

Convert 0.5 into a **fraction**. You must simplify your answer to lowest terms.

78) Assistent #47352 "47352 - Converting Decimals to Fractions - 7th Grade"

Convert 0.6 into a **fraction**. You must simplify your answer to lowest terms.

79) Assistent #47353 "47353 - Converting Decimals to Fractions - 7th Grade"

Convert 0.7 into a **fraction**. You must simplify your answer to lowest terms.

80) Assistent #47354 "47354 - Converting Decimals to Fractions - 7th Grade"

Convert 0.8 into a **fraction**. You must simplify your answer to lowest terms.

81) Assistent #47355 "47355 - Converting Decimals to Fractions - 7th Grade"

Convert 0.25 into a **fraction**. You must simplify your answer to lowest terms.

82) Assistent #47356 "47356 - Converting Decimals to Fractions - 7th Grade"

Convert 0.75 into a **fraction**. You must simplify your answer to lowest terms.

83) Assistent #47357 "47357 - Converting Decimals to Fractions - 7th Grade"

Convert 0.1 into a **fraction**. You must simplify your answer to lowest terms.

84) Assistent #47358 "47358 - Converting Decimals to Fractions - 7th Grade"

Convert 0.2 into a **fraction**. You must simplify your answer to lowest terms.

85) Assistent #47359 "47359 - Converting Decimals to Fractions - 7th Grade"

Convert 0.3 into a **fraction**. You must simplify your answer to lowest terms.

86) Assistent #47360 "47360 - Converting Decimals to Fractions - 7th Grade"

Convert 0.4 into a **fraction**. You must simplify your answer to lowest terms.

88) Assistent #47362 "47362 - Converting Decimals to Fractions - 7th Grade"

Convert 0.6 into a **fraction**. You must simplify your answer to lowest terms.

89) Assistent #47363 "47363 - Converting Decimals to Fractions - 7th Grade"

Convert 0.7 into a **fraction**. You must simplify your answer to lowest terms.

90) Assistent #47364 "47364 - Converting Decimals to Fractions - 7th Grade"

Convert 0.8 into a **fraction**. You must simplify your answer to lowest terms.

91) Assistent #47365 "47365 - Converting Decimals to Fractions - 7th Grade"

Convert 0.25 into a **fraction**. You must simplify your answer to lowest terms.

92) Assistent #47366 "47366 - Converting Decimals to Fractions - 7th Grade"

Convert 0.75 into a **fraction**. You must simplify your answer to lowest terms.

93) Assistent #47367 "47367 - Converting Decimals to Fractions - 7th Grade"

Convert 0.1 into a **fraction**. You must simplify your answer to lowest terms.

94) Assistent #47368 "47368 - Converting Decimals to Fractions - 7th Grade"

Convert 0.2 into a **fraction**. You must simplify your answer to lowest terms.

96) Assistent #47370 "47370 - Converting Decimals to Fractions - 7th Grade"

Convert 0.4 into a **fraction**. You must simplify your answer to lowest terms.

97) Assistent #47371 "47371 - Converting Decimals to Fractions - 7th Grade"

Convert 0.5 into a **fraction**. You must simplify your answer to lowest terms.

98) Assistent #47372 "47372 - Converting Decimals to Fractions - 7th Grade"

Convert 0.6 into a **fraction**. You must simplify your answer to lowest terms.

99) Assistent #47373 "47373 - Converting Decimals to Fractions - 7th Grade"

Convert 0.7 into a **fraction**. You must simplify your answer to lowest terms.

100) Assistent #47374 "47374 - Converting Decimals to Fractions - 7th Grade"

Convert 0.8 into a **fraction**. You must simplify your answer to lowest terms.

1) Assistent #115331 "115331 - 107574 - Lvl. 3 Composition of Functions - Adding "

Suppose you have two expressions:

$$b = 5x^3 + 6x^2 + 8x^4$$

$$p = 3x^4 + 2x^3 + 8x^2 + 6$$

Fill in the blank for $b + p =$ _____

2) Assistent #115332 "115332 - 107574 - Lvl. 3 Composition of Functions - Adding "

Suppose you have two expressions:

$$c = 1x^3 + 10x^2 + 6x^4$$

$$s = 8x^4 + 2x^3 + 3x^2 + 7$$

Fill in the blank for $c + s =$ _____

3) Assistent #115333 "115333 - 107574 - Lvl. 3 Composition of Functions - Adding "

Suppose you have two expressions:

$$g = 2x^3 + 10x^2 + 3x^4$$

$$z = 6x^4 + 2x^3 + 4x^2 + 8$$

Fill in the blank for $g + z =$ _____

4) Assistent #115334 "115334 - 107574 - Lvl. 3 Composition of Functions - Adding "

Suppose you have two expressions:

$$h = 5x^3 + 8x^2 + 4x^4$$

$$w = 2x^4 + 8x^3 + 3x^2 + 5$$

Fill in the blank for $h + w =$ _____

5) Assistent #115335 "115335 - 107574 - Lvl. 3 Composition of Functions - Adding "

Suppose you have two expressions:

$$k = 4x^3 + 2x^2 + 10x^4$$

$$u = 2x^4 + 6x^3 + 10x^2 + 10$$

Fill in the blank for $k + u =$ _____

6) Assistent #115336 "115336 - 107574 - Lvl. 3 Composition of Functions - Adding "

Suppose you have two expressions:

$$i = 1x^3 + 2x^2 + 2x^4$$

$$z = 6x^4 + 4x^3 + 3x^2 + 2$$

Fill in the blank for $i + z =$ _____

7) Assistent #115337 "115337 - 107574 - Lvl. 3 Composition of Functions - Adding "

Suppose you have two expressions:

$$a = 10x^3 + 4x^2 + 4x^4$$

$$z = 5x^4 + 5x^3 + 5x^2 + 5$$

Fill in the blank for $a + z =$ _____

8) Assistent #115338 "115338 - 107574 - Lvl. 3 Composition of Functions - Adding "

Suppose you have two expressions:

$$l = 9x^3 + 3x^2 + 3x^4$$

$$y = 8x^4 + 3x^3 + 2x^2 + 3$$

Fill in the blank for $l + y =$ _____

9) Assistent #115339 "115339 - 107574 - Lvl. 3 Composition of Functions - Adding "

Suppose you have two expressions:

$$d = 7x^3 + 9x^2 + 6x^4$$

$$o = 3x^4 + 8x^3 + 7x^2 + 6$$

Fill in the blank for $d + o =$ _____

10) Assistent #115340 "115340 - 107574 - Lvl. 3 Composition of Functions - Adding "

Suppose you have two expressions:

$$i = 5x^3 + 4x^2 + 10x^4$$

$$w = 10x^4 + 7x^3 + 3x^2 + 8$$

Fill in the blank for $i + w =$ _____

11) Assistent #115341 "115341 - 107574 - Lvl. 3 Composition of Functions - Adding "

Suppose you have two expressions:

$$d = 10x^3 + 7x^2 + 2x^4$$

$$v = 1x^4 + 1x^3 + 1x^2 + 2$$

Fill in the blank for $d + v =$ _____

12) Assistent #115342 "115342 - 107574 - Lvl. 3 Composition of Functions - Adding "

Suppose you have two expressions:

$$j = 10x^3 + 7x^2 + 8x^4$$

$$x = 7x^4 + 5x^3 + 7x^2 + 4$$

Fill in the blank for $j + x =$ _____

13) Assistent #115343 "115343 - 107574 - Lvl. 3 Composition of Functions - Adding "

Suppose you have two expressions:

$$e = 5x^3 + 2x^2 + 5x^4$$

$$o = 2x^4 + 3x^3 + 7x^2 + 3$$

Fill in the blank for $e + o =$ _____

14) Assistent #115344 "115344 - 107574 - Lvl. 3 Composition of Functions - Adding "

Suppose you have two expressions:

$$a = 10x^3 + 4x^2 + 4x^4$$

$$w = 5x^4 + 4x^3 + 4x^2 + 9$$

Fill in the blank for $a + w =$ _____

15) Assistent #115345 "115345 - 107574 - Lvl. 3 Composition of Functions - Adding "

Suppose you have two expressions:

$$l = 8x^3 + 6x^2 + 8x^4$$

$$s = 9x^4 + 8x^3 + 1x^2 + 2$$

Fill in the blank for $l + s =$ _____

16) Assistent #115346 "115346 - 107574 - Lvl. 3 Composition of Functions - Adding "

Suppose you have two expressions:

$$k = 9x^3 + 8x^2 + 2x^4$$

$$s = 5x^4 + 1x^3 + 1x^2 + 1$$

Fill in the blank for $k + s =$ _____

17) Assistent #115347 "115347 - 107574 - Lvl. 3 Composition of Functions - Adding "

Suppose you have two expressions:

$$j = 9x^3 + 3x^2 + 10x^4$$

$$x = 10x^4 + 4x^3 + 4x^2 + 2$$

Fill in the blank for $j + x =$ _____

18) Assistent #115348 "115348 - 107574 - Lvl. 3 Composition of Functions - Adding "

Suppose you have two expressions:

$$g = 4x^3 + 3x^2 + 8x^4$$

$$z = 6x^4 + 5x^3 + 9x^2 + 9$$

Fill in the blank for $g + z =$ _____

19) Assistent #115349 "115349 - 107574 - Lvl. 3 Composition of Functions - Adding "

Suppose you have two expressions:

$$h = 5x^3 + 4x^2 + 8x^4$$

$$p = 1x^4 + 8x^3 + 2x^2 + 7$$

Fill in the blank for $h + p =$ _____

20) Assistent #115350 "115350 - 107574 - Lvl. 3 Composition of Functions - Adding "

Suppose you have two expressions:

$$k = 5x^3 + 8x^2 + 3x^4$$

$$w = 3x^4 + 1x^3 + 6x^2 + 10$$

Fill in the blank for $k + w =$ _____

21) Assistent #115351 "115351 - 114867 Lvl. 1 Composition of Functions - Subtracting"

Suppose you have two expressions:

$$l = 6x^2 + 9x + 8$$

$$z = 7x + 3$$

Fill in the blank for $l - z =$ _____

22) Assistent #115352 "115352 - 114867 Lvl. 1 Composition of Functions - Subtracting"

Suppose you have two expressions:

$$d = 2x^2 + 6x + 4$$

$$q = 6x + 1$$

Fill in the blank for $d - q =$ _____

23) Assistent #115353 "115353 - 114867 Lvl. 1 Composition of Functions - Subtracting"

Suppose you have two expressions:

$$e = 7x^2 + 9x + 6$$

$$w = 7x + 7$$

Fill in the blank for $e - w =$ _____

24) Assistent #115354 "115354 - 114867 Lvl. 1 Composition of Functions - Subtracting"

Suppose you have two expressions:

$$h = 9x^2 + 6x + 1$$

$$p = 8x + 4$$

Fill in the blank for $h - p =$ _____

25) Assistent #115355 "115355 - 114867 Lvl. 1 Composition of Functions - Subtracting"

Suppose you have two expressions:

$$d = 1x^2 + 3x + 2$$

$$w = 4x + 10$$

Fill in the blank for $d - w =$ _____

26) Assistent #115356 "115356 - 114867 Lvl. 1 Composition of Functions - Subtracting"

Suppose you have two expressions:

$$a = 6x^2 + 7x + 10$$

$$x = 7x + 10$$

Fill in the blank for $a - x =$ _____

27) Assistent #115357 "115357 - 114867 Lvl. 1 Composition of Functions - Subtracting"

Suppose you have two expressions:

$$g = 5x^2 + 6x + 1$$

$$u = 4x + 9$$

Fill in the blank for $g - u =$ _____

28) Assistent #115358 "115358 - 114867 Lvl. 1 Composition of Functions - Subtracting"

Suppose you have two expressions:

$$f = 4x^2 + 3x + 5$$

$$w = 1x + 7$$

Fill in the blank for $f - w =$ _____

29) Assistent #115359 "115359 - 114867 Lvl. 1 Composition of Functions - Subtracting"

Suppose you have two expressions:

$$e = 8x^2 + 9x + 8$$

$$z = 10x + 1$$

Fill in the blank for $e - z =$ _____

30) Assistent #115360 "115360 - 114867 Lvl. 1 Composition of Functions - Subtracting"

Suppose you have two expressions:

$$b = 7x^2 + 3x + 7$$

$$w = 2x + 6$$

Fill in the blank for $b - w =$ _____

31) Assistent #115361 "115361 - 114867 Lvl. 1 Composition of Functions - Subtracting"

Suppose you have two expressions:

$$j = 7x^2 + 4x + 5$$

$$y = 6x + 4$$

Fill in the blank for $j - y =$ _____

32) Assistent #115362 "115362 - 114867 Lvl. 1 Composition of Functions - Subtracting"

Suppose you have two expressions:

$$g = 8x^2 + 6x + 6$$

$$x = 1x + 7$$

Fill in the blank for $g - x =$ _____

33) Assistent #115363 "115363 - 114867 Lvl. 1 Composition of Functions - Subtracting"

Suppose you have two expressions:

$$e = 4x^2 + 7x + 8$$

$$x = 10x + 10$$

Fill in the blank for $e - x =$ _____

34) Assistent #115364 "115364 - 114867 Lvl. 1 Composition of Functions - Subtracting"

Suppose you have two expressions:

$$j = 6x^2 + 1x + 2$$

$$z = 3x + 3$$

Fill in the blank for $j - z =$ _____

35) Assistent #115365 "115365 - 114867 Lvl. 1 Composition of Functions - Subtracting"

Suppose you have two expressions:

$$h = 3x^2 + 9x + 7$$

$$y = 5x + 5$$

Fill in the blank for $h - y =$ _____

36) Assistent #115366 "115366 - 114867 Lvl. 1 Composition of Functions - Subtracting"

Suppose you have two expressions:

$$e = 3x^2 + 9x + 9$$

$$s = 2x + 6$$

Fill in the blank for $e - s =$ _____

37) Assistent #115367 "115367 - 114867 Lvl. 1 Composition of Functions - Subtracting"

Suppose you have two expressions:

$$a = 7x^2 + 9x + 3$$

$$p = 2x + 8$$

Fill in the blank for $a - p =$ _____

38) Assistent #115368 "115368 - 114867 Lvl. 1 Composition of Functions - Subtracting"

Suppose you have two expressions:

$$h = 3x^2 + 2x + 5$$

$$r = 5x + 2$$

Fill in the blank for $h - r =$ _____

39) Assistent #115369 "115369 - 114867 Lvl. 1 Composition of Functions - Subtracting"

Suppose you have two expressions:

$$i = 1x^2 + 1x + 8$$

$$u = 4x + 1$$

Fill in the blank for $i - u =$ _____

40) Assistent #115370 "115370 - 114867 Lvl. 1 Composition of Functions - Subtracting"

Suppose you have two expressions:

$$g = 1x^2 + 6x + 7$$

$$n = 2x + 7$$

Fill in the blank for $g - n =$ _____

41) Assistent #115371 "115371 - Lvl. 2 Composition of Functions - Subtracting"

Suppose you have two expressions:

$$d = 5x^2 + 2 + 4x$$

$$u = 5x + 7x^2 + 6$$

Fill in the blank for $d - u =$ _____

42) Assistent #115372 "115372 - Lvl. 2 Composition of Functions - Subtracting"

Suppose you have two expressions:

$$j = 3x^2 + 5 + 7x$$

$$s = 2x + 4x^2 + 3$$

Fill in the blank for $j - s =$ _____

43) Assistent #115373 "115373 - Lvl. 2 Composition of Functions - Subtracting"

Suppose you have two expressions:

$$h = 4x^2 + 10 + 7x$$

$$o = 5x + 1x^2 + 3$$

Fill in the blank for $h - o =$ _____

44) Assistent #115374 "115374 - Lvl. 2 Composition of Functions - Subtracting"

Suppose you have two expressions:

$$i = 6x^2 + 7 + 7x$$

$$q = 5x + 7x^2 + 7$$

Fill in the blank for $i - q =$ _____

45) Assistent #115375 "115375 - Lvl. 2 Composition of Functions - Subtracting"

Suppose you have two expressions:

$$j = 10x^2 + 1 + 2x$$

$$u = 5x + 8x^2 + 9$$

Fill in the blank for $j - u =$ _____

46) Assistent #115376 "115376 - Lvl. 2 Composition of Functions - Subtracting"

Suppose you have two expressions:

$$i = 9x^2 + 3 + 9x$$

$$s = 8x + 10x^2 + 2$$

Fill in the blank for $i - s =$ _____

47) Assistent #115377 "115377 - Lvl. 2 Composition of Functions - Subtracting"

Suppose you have two expressions:

$$c = 3x^2 + 1 + 6x$$

$$y = 9x + 6x^2 + 1$$

Fill in the blank for $c - y =$ _____

48) Assistent #115378 "115378 - Lvl. 2 Composition of Functions - Subtracting"

Suppose you have two expressions:

$$h = 10x^2 + 8 + 3x$$

$$y = 9x + 8x^2 + 7$$

Fill in the blank for $h - y =$ _____

49) Assisment #115379 "115379 - Lvl. 2 Composition of Functions - Subtracting"

Suppose you have two expressions:

$$i = 1x^2 + 1 + 3x$$

$$z = 8x + 2x^2 + 1$$

Fill in the blank for $i - z =$ _____

50) Assisment #115380 "115380 - Lvl. 2 Composition of Functions - Subtracting"

Suppose you have two expressions:

$$k = 7x^2 + 9 + 9x$$

$$m = 4x + 5x^2 + 9$$

Fill in the blank for $k - m =$ _____

51) Assisment #115381 "115381 - Lvl. 2 Composition of Functions - Subtracting"

Suppose you have two expressions:

$$h = 1x^2 + 2 + 9x$$

$$m = 5x + 8x^2 + 1$$

Fill in the blank for $h - m =$ _____

52) Assisment #115382 "115382 - Lvl. 2 Composition of Functions - Subtracting"

Suppose you have two expressions:

$$c = 6x^2 + 8 + 8x$$

$$u = 9x + 3x^2 + 8$$

Fill in the blank for $c - u =$ _____

53) Assisment #115383 "115383 - Lvl. 2 Composition of Functions - Subtracting"

Suppose you have two expressions:

$$j = 5x^2 + 1 + 10x$$

$$t = 10x + 3x^2 + 6$$

Fill in the blank for $j - t =$ _____

54) Assisment #115384 "115384 - Lvl. 2 Composition of Functions - Subtracting"

Suppose you have two expressions:

$$k = 9x^2 + 2 + 8x$$

$$s = 3x + 10x^2 + 9$$

Fill in the blank for $k - s =$ _____

55) Assistent #115385 "115385 - Lvl. 2 Composition of Functions - Subtracting"

Suppose you have two expressions:

$$k = 6x^2 + 1 + 2x$$

$$x = 8x + 2x^2 + 1$$

Fill in the blank for $k - x =$ _____

56) Assistent #115386 "115386 - Lvl. 2 Composition of Functions - Subtracting"

Suppose you have two expressions:

$$f = 5x^2 + 5 + 3x$$

$$w = 8x + 3x^2 + 6$$

Fill in the blank for $f - w =$ _____

57) Assistent #115387 "115387 - Lvl. 2 Composition of Functions - Subtracting"

Suppose you have two expressions:

$$h = 2x^2 + 1 + 7x$$

$$o = 10x + 3x^2 + 2$$

Fill in the blank for $h - o =$ _____

58) Assistent #115388 "115388 - Lvl. 2 Composition of Functions - Subtracting"

Suppose you have two expressions:

$$k = 1x^2 + 5 + 9x$$

$$s = 7x + 4x^2 + 1$$

Fill in the blank for $k - s =$ _____

59) Assistent #115389 "115389 - Lvl. 2 Composition of Functions - Subtracting"

Suppose you have two expressions:

$$f = 10x^2 + 7 + 8x$$

$$x = 5x + 1x^2 + 2$$

Fill in the blank for $f - x =$ _____

60) Assistent #115390 "115390 - Lvl. 2 Composition of Functions - Subtracting"

Suppose you have two expressions:

$$i = 10x^2 + 7 + 1x$$

$$x = 10x + 2x^2 + 9$$

Fill in the blank for $i - x =$ _____

61) Assistent #115391 "115391 - 107575 - Lvl. 2 Composition of Functions - Adding "

Suppose you have two expressions:

$$i = 1x^2 + 8 + 9x$$

$$o = 8x + 10x^2 + 5$$

Fill in the blank for $i + o =$ _____

62) Assistent #115392 "115392 - 107575 - Lvl. 2 Composition of Functions - Adding "

Suppose you have two expressions:

$$b = 5x^2 + 6 + 4x$$

$$n = 3x + 2x^2 + 9$$

Fill in the blank for $b + n =$ _____

63) Assistent #115393 "115393 - 107575 - Lvl. 2 Composition of Functions - Adding "

Suppose you have two expressions:

$$l = 3x^2 + 4 + 10x$$

$$y = 10x + 8x^2 + 3$$

Fill in the blank for $l + y =$ _____

64) Assistent #115394 "115394 - 107575 - Lvl. 2 Composition of Functions - Adding "

Suppose you have two expressions:

$$f = 7x^2 + 3 + 9x$$

$$w = 3x + 2x^2 + 4$$

Fill in the blank for $f + w =$ _____

65) Assistent #115395 "115395 - 107575 - Lvl. 2 Composition of Functions - Adding "

Suppose you have two expressions:

$$d = 10x^2 + 1 + 7x$$

$$t = 2x + 10x^2 + 5$$

Fill in the blank for $d + t =$ _____

66) Assistent #115396 "115396 - 107575 - Lvl. 2 Composition of Functions - Adding "

Suppose you have two expressions:

$$d = 2x^2 + 5 + 6x$$

$$y = 4x + 3x^2 + 9$$

Fill in the blank for $d + y =$ _____

67) Assistent #115397 "115397 - 107575 - Lvl. 2 Composition of Functions - Adding "

Suppose you have two expressions:

$$c = 7x^2 + 8 + 2x$$

$$o = 8x + 10x^2 + 5$$

Fill in the blank for $c + o =$ _____

68) Assistent #115398 "115398 - 107575 - Lvl. 2 Composition of Functions - Adding "

Suppose you have two expressions:

$$d = 9x^2 + 9 + 8x$$

$$n = 9x + 9x^2 + 3$$

Fill in the blank for $d + n =$ _____

69) Assistent #115399 "115399 - 107575 - Lvl. 2 Composition of Functions - Adding "

Suppose you have two expressions:

$$f = 3x^2 + 9 + 2x$$

$$v = 3x + 8x^2 + 5$$

Fill in the blank for $f + v =$ _____

70) Assistent #115400 "115400 - 107575 - Lvl. 2 Composition of Functions - Adding "

Suppose you have two expressions:

$$a = 7x^2 + 8 + 2x$$

$$s = 6x + 10x^2 + 5$$

Fill in the blank for $a + s =$ _____

71) Assistent #115401 "115401 - 107575 - Lvl. 2 Composition of Functions - Adding "

Suppose you have two expressions:

$$j = 1x^2 + 10 + 8x$$

$$z = 3x + 1x^2 + 10$$

Fill in the blank for $j + z =$ _____

72) Assistent #115402 "115402 - 107575 - Lvl. 2 Composition of Functions - Adding "

Suppose you have two expressions:

$$h = 8x^2 + 4 + 7x$$

$$o = 5x + 1x^2 + 7$$

Fill in the blank for $h + o =$ _____

73) Assistent #115403 "115403 - 107575 - Lvl. 2 Composition of Functions - Adding "

Suppose you have two expressions:

$$b = 10x^2 + 6 + 5x$$

$$q = 9x + 3x^2 + 8$$

Fill in the blank for $b + q =$ _____

74) Assistent #115404 "115404 - 107575 - Lvl. 2 Composition of Functions - Adding "

Suppose you have two expressions:

$$e = 9x^2 + 4 + 10x$$

$$q = 6x + 3x^2 + 5$$

Fill in the blank for $e + q =$ _____

75) Assistent #115405 "115405 - 107575 - Lvl. 2 Composition of Functions - Adding "

Suppose you have two expressions:

$$d = 9x^2 + 1 + 9x$$

$$t = 7x + 10x^2 + 9$$

Fill in the blank for $d + t =$ _____

76) Assistent #115406 "115406 - 107575 - Lvl. 2 Composition of Functions - Adding "

Suppose you have two expressions:

$$j = 10x^2 + 9 + 6x$$

$$y = 2x + 4x^2 + 8$$

Fill in the blank for $j + y =$ _____

77) Assistent #115407 "115407 - 107575 - Lvl. 2 Composition of Functions - Adding "

Suppose you have two expressions:

$$f = 1x^2 + 9 + 6x$$

$$z = 7x + 6x^2 + 4$$

Fill in the blank for $f + z =$ _____

78) Assistent #115408 "115408 - 107575 - Lvl. 2 Composition of Functions - Adding "

Suppose you have two expressions:

$$e = 8x^2 + 4 + 7x$$

$$r = 10x + 2x^2 + 7$$

Fill in the blank for $e + r =$ _____

79) Assistent #115409 "115409 - 107575 - Lvl. 2 Composition of Functions - Adding "

Suppose you have two expressions:

$$d = 8x^2 + 3 + 10x$$

$$y = 6x + 6x^2 + 2$$

Fill in the blank for $d + y =$ _____

80) Assistent #115410 "115410 - 107575 - Lvl. 2 Composition of Functions - Adding "

Suppose you have two expressions:

$$c = 2x^2 + 6 + 10x$$

$$m = 6x + 1x^2 + 8$$

Fill in the blank for $c + m =$ _____

81) Assistent #115411 "115411 - 106932 - Lvl. 1 Composition of Functions - Adding "

Suppose you have two expressions:

$$a = 4x^2 + 8x + 2$$

$$r = 4x + 6$$

Fill in the blank for $a + r =$ _____

82) Assisment #115412 "115412 - 106932 - Lvl. 1 Composition of Functions - Adding "

Suppose you have two expressions:

$$a = 1x^2 + 1x + 9$$

$$t = 4x + 6$$

Fill in the blank for $a + t =$ _____

83) Assisment #115413 "115413 - 106932 - Lvl. 1 Composition of Functions - Adding "

Suppose you have two expressions:

$$f = 3x^2 + 5x + 5$$

$$u = 2x + 1$$

Fill in the blank for $f + u =$ _____

84) Assisment #115414 "115414 - 106932 - Lvl. 1 Composition of Functions - Adding "

Suppose you have two expressions:

$$g = 6x^2 + 5x + 3$$

$$r = 6x + 1$$

Fill in the blank for $g + r =$ _____

85) Assisment #115415 "115415 - 106932 - Lvl. 1 Composition of Functions - Adding "

Suppose you have two expressions:

$$f = 8x^2 + 4x + 4$$

$$z = 9x + 8$$

Fill in the blank for $f + z =$ _____

86) Assisment #115416 "115416 - 106932 - Lvl. 1 Composition of Functions - Adding "

Suppose you have two expressions:

$$l = 9x^2 + 2x + 2$$

$$r = 10x + 9$$

Fill in the blank for $l + r =$ _____

87) Assistent #115417 "115417 - 106932 - Lvl. 1 Composition of Functions - Adding "

Suppose you have two expressions:

$$b = 6x^2 + 3x + 8$$

$$q = 3x + 8$$

Fill in the blank for $b + q =$ _____

88) Assistent #115418 "115418 - 106932 - Lvl. 1 Composition of Functions - Adding "

Suppose you have two expressions:

$$k = 3x^2 + 7x + 6$$

$$x = 5x + 4$$

Fill in the blank for $k + x =$ _____

89) Assistent #115419 "115419 - 106932 - Lvl. 1 Composition of Functions - Adding "

Suppose you have two expressions:

$$a = 3x^2 + 7x + 5$$

$$y = 6x + 7$$

Fill in the blank for $a + y =$ _____

90) Assistent #115420 "115420 - 106932 - Lvl. 1 Composition of Functions - Adding "

Suppose you have two expressions:

$$g = 4x^2 + 6x + 6$$

$$o = 6x + 4$$

Fill in the blank for $g + o =$ _____

91) Assistent #115421 "115421 - 106932 - Lvl. 1 Composition of Functions - Adding "

Suppose you have two expressions:

$$h = 4x^2 + 5x + 10$$

$$x = 1x + 3$$

Fill in the blank for $h + x =$ _____

92) Assistent #115422 "115422 - 106932 - Lvl. 1 Composition of Functions - Adding "

Suppose you have two expressions:

$$j = 8x^2 + 2x + 2$$

$$x = 10x + 10$$

Fill in the blank for $j + x =$ _____

93) Assisment #115423 "115423 - 106932 - Lvl. 1 Composition of Functions - Adding "

Suppose you have two expressions:

$$d = 3x^2 + 8x + 5$$

$$r = 8x + 9$$

Fill in the blank for $d + r =$ _____

94) Assisment #115424 "115424 - 106932 - Lvl. 1 Composition of Functions - Adding "

Suppose you have two expressions:

$$m = 5x^2 + 5x + 2$$

$$s = 7x + 6$$

Fill in the blank for $m + s =$ _____

95) Assisment #115425 "115425 - 106932 - Lvl. 1 Composition of Functions - Adding "

Suppose you have two expressions:

$$g = 7x^2 + 8x + 9$$

$$q = 1x + 10$$

Fill in the blank for $g + q =$ _____

96) Assisment #115426 "115426 - 106932 - Lvl. 1 Composition of Functions - Adding "

Suppose you have two expressions:

$$h = 10x^2 + 4x + 2$$

$$p = 1x + 5$$

Fill in the blank for $h + p =$ _____

97) Assisment #115427 "115427 - 106932 - Lvl. 1 Composition of Functions - Adding "

Suppose you have two expressions:

$$b = 3x^2 + 9x + 2$$

$$z = 8x + 7$$

Fill in the blank for $b + z =$ _____

98) Assistent #115428 "115428 - 106932 - Lvl. 1 Composition of Functions - Adding "

Suppose you have two expressions:

$$h = 1x^2 + 9x + 9$$

$$q = 4x + 8$$

Fill in the blank for $h + q =$ _____

99) Assistent #115429 "115429 - 106932 - Lvl. 1 Composition of Functions - Adding "

Suppose you have two expressions:

$$f = 2x^2 + 5x + 8$$

$$r = 6x + 5$$

Fill in the blank for $f + r =$ _____

100) Assistent #115430 "115430 - 106932 - Lvl. 1 Composition of Functions - Adding "

Suppose you have two expressions:

$$h = 8x^2 + 8x + 6$$

$$r = 3x + 5$$

Fill in the blank for $h + r =$ _____

101) Assistent #115431 "115431 - 107017 - Composition of Funtions - Adding Word Problem"

Betty has a rule for calculating how many crunches she does on weekdays (WD) and how many crunches she does on weekends (WE). Her rules depend on the number of slices of pizza (x) she eats.

$$WD = 10x^2 + 8x + 4$$

$$WE = 6x + 5$$

Write an equation for the number of crunches she does in a week.

Fill in the blank ONE WEEK = _____

102) Assistent #115432 "115432 - 107017 - Composition of Funtions - Adding Word Problem"

Carl has a rule for calculating how many jumping jacks he must do from Monday morning to Friday night (WD - Weekdays) and how many jumping jacks he must do From Saturday morning to Sunday night (WE - Weekend). His rules depend on the number of slices of pizza (x) he eats.

$$\begin{aligned} \text{WD} &= 8x^2 + 8x + 8 \\ \text{WE} &= 1x + 5 \end{aligned}$$

Write an equation for the number of crunches he does in a week.
Fill in the blank ONE WEEK = _____

103) Assistent #115433 "115433 - 107017 - Composition of Funtions - Adding Word Problem"

Bill has a rule for calculating how many push ups he does on weekdays (WD) and how many push ups he does on weekends (WE). His rules depend on the number of slices of cake (x) he eats.

$$\begin{aligned} \text{WD} &= 2x^2 + 6x + 7 \\ \text{WE} &= 8x + 5 \end{aligned}$$

Write an equation for the number of push ups he does in a week.
Fill in the blank ONE WEEK = _____

104) Assistent #115434 "115434 - 107017 - Composition of Funtions - Adding Word Problem"

Ashley has a rule for calculating how many push ups she does on weekdays (WD) and how many push ups she does on weekends (WE). Her rules depend on the number of cupcakes (x) she eats.

$$\begin{aligned} \text{WD} &= 8x^2 + 6x + 4 \\ \text{WE} &= 10x + 7 \end{aligned}$$

Write an equation for the number of push ups she does in a week.
Fill in the blank ONE WEEK = _____

105) Assistent #115435 "115435 - 107017 - Composition of Funtions - Adding Word Problem"

Ashley has a rule for calculating how many push ups she does on weekdays (WD) and how many push ups she does on weekends (WE). Her rules depend on the number of bowls of ice cream (x) she eats.

$$\begin{aligned} \text{WD} &= 8x^2 + 2x + 9 \\ \text{WE} &= 10x + 2 \end{aligned}$$

Write an equation for the number of push ups she does in a week.
Fill in the blank ONE WEEK = _____

106) Assistent #115436 "115436 - 107017 - Composition of Funtions - Adding Word Problem"

Candace has a rule for calculating how many jumping jacks she does on weekdays (WD)

and how many jumping jacks she does on weekends (WE). Her rules depend on the number of jellybeans (x) she eats.

$$\begin{aligned}WD &= 4x^2 + 7x + 4 \\WE &= 4x + 5\end{aligned}$$

Write an equation for the number of jumping jacks she does in a week.

Fill in the blank ONE WEEK = _____

107) Assistent #115437 "115437 - 107017 - Composition of Funtions - Adding Word Problem"

Candace has a rule for calculating how many jumping jacks she does on weekdays (WD) and how many jumping jacks she does on weekends (WE). Her rules depend on the number of bowls of ice cream (x) she eats.

$$\begin{aligned}WD &= 10x^2 + 9x + 4 \\WE &= 9x + 7\end{aligned}$$

Write an equation for the number of jumping jacks she does in a week.

Fill in the blank ONE WEEK = _____

108) Assistent #115438 "115438 - 107017 - Composition of Funtions - Adding Word Problem"

Brian has a rule for calculating how many jumping jacks he does on weekdays (WD) and how many jumping jacks he does on weekends (WE). His rules depend on the number of jellybeans (x) he eats.

$$\begin{aligned}WD &= 4x^2 + 8x + 1 \\WE &= 9x + 5\end{aligned}$$

Write an equation for the number of jumping jacks he does in a week.

Fill in the blank ONE WEEK = _____

109) Assistent #115439 "115439 - 107017 - Composition of Funtions - Adding Word Problem"

Bill has a rule for calculating how many jumping jacks he does on weekdays (WD) and how many jumping jacks he does on weekends (WE). His rules depend on the number of bags of potato chips (x) he eats.

$$\begin{aligned}WD &= 5x^2 + 1x + 9 \\WE &= 1x + 8\end{aligned}$$

Write an equation for the number of jumping jacks he does in a week.

Fill in the blank ONE WEEK = _____

110) Assistent #115440 "115440 - 107017 - Composition of Funtions - Adding Word Problem"

Betty has a rule for calculating how many push ups she does on weekdays (WD) and how many push ups she does on weekends (WE). Her rules depend on the number of bags of potato chips (x) she eats.

$$WD = 7x^2 + 3x + 7$$

$$WE = 1x + 8$$

Write an equation for the number of push ups she does in a week.

Fill in the blank ONE WEEK = _____

111) Assistent #115441 "115441 - 107573 - Composition of Functions Adding (Word Problem Lvl. 2)"

The State Fair was open from May to August last year. In May and June, tickets were \$37 per adult and \$23 per child. In July and August, tickets were \$77 per adult and \$35 per child. The park made \$345 for food sales in May and June and \$449 for food sales in July and August.

$$\text{May and June} = 37A + 23C + 345$$

$$\text{July and August} = 77A + 35C + 449$$

Write an expression for the amount of money Get Soaked Water Park made from food and ticket sales last year.

112) Assistent #115442 "115442 - 107573 - Composition of Functions Adding (Word Problem Lvl. 2)"

44 Flags was open from May to August last year. In May and June, tickets were \$71 per adult and \$29 per child. In July and August, tickets were \$43 per adult and \$39 per child. The park made \$166 for food sales in May and June and \$292 for food sales in July and August.

$$\text{May and June} = 71A + 29C + 166$$

$$\text{July and August} = 43A + 39C + 292$$

Write an expression for the amount of money Get Soaked Water Park made from food and ticket sales last year.

113) Assistent #115443 "115443 - 107573 - Composition of Functions Adding (Word Problem Lvl. 2)"

Get Soaked Water Park was open from May to August last year. In May and June, tickets were \$47 per adult and \$24 per child. In July and August, tickets were \$78 per adult and \$38 per child. The park made \$206 for food sales in May and June and \$268 for food sales in July and August.

$$\text{May and June} = 47A + 24C + 206$$

$$\text{July and August} = 78A + 38C + 268$$

Write an expression for the amount of money Get Soaked Water Park made

from food and ticket sales last year.

114) Assistent #115444 "115444 - 107573 - Composition of Functions Adding (Word Problem Lvl. 2)"

Get Soaked Water Park was open from May to August last year. In May and June, tickets were \$53 per adult and \$34 per child. In July and August, tickets were \$83 per adult and \$31 per child. The park made \$271 for food sales in May and June and \$632 for food sales in July and August.

May and June = $53A+34C+271$

July and August = $83A+31C+632$

Write an expression for the amount of money Get Soaked Water Park made from food and ticket sales last year.

115) Assistent #115445 "115445 - 107573 - Composition of Functions Adding (Word Problem Lvl. 2)"

44 Flags was open from May to August last year. In May and June, tickets were \$58 per adult and \$21 per child. In July and August, tickets were \$55 per adult and \$43 per child. The park made \$151 for food sales in May and June and \$623 for food sales in July and August.

May and June = $58A+21C+151$

July and August = $55A+43C+623$

Write an expression for the amount of money Get Soaked Water Park made from food and ticket sales last year.

116) Assistent #115446 "115446 - 107573 - Composition of Functions Adding (Word Problem Lvl. 2)"

The State Fair was open from May to August last year. In May and June, tickets were \$36 per adult and \$25 per child. In July and August, tickets were \$58 per adult and \$32 per child. The park made \$216 for food sales in May and June and \$286 for food sales in July and August.

May and June = $36A+25C+216$

July and August = $58A+32C+286$

Write an expression for the amount of money Get Soaked Water Park made from food and ticket sales last year.

117) Assistent #115447 "115447 - 107573 - Composition of Functions Adding (Word Problem Lvl. 2)"

Rollercoaster Rodeo was open from May to August last year. In May and June, tickets were \$58 per adult and \$39 per child. In July and August, tickets were \$77 per adult and \$43 per child. The park made \$200 for food sales in May and June and \$547 for food sales

in July and August.

May and June = $58A+39C+200$

July and August = $77A+43C+547$

Write an expression for the amount of money Get Soaked Water Park made from food and ticket sales last year.

118) Assistent #115448 "115448 - 107573 - Composition of Functions Adding (Word Problem Lvl. 2)"

Get Soaked Water Park was open from May to August last year. In May and June, tickets were \$49 per adult and \$36 per child. In July and August, tickets were \$54 per adult and \$45 per child. The park made \$289 for food sales in May and June and \$411 for food sales in July and August.

May and June = $49A+36C+289$

July and August = $54A+45C+411$

Write an expression for the amount of money Get Soaked Water Park made from food and ticket sales last year.

119) Assistent #115449 "115449 - 107573 - Composition of Functions Adding (Word Problem Lvl. 2)"

44 Flags was open from May to August last year. In May and June, tickets were \$56 per adult and \$21 per child. In July and August, tickets were \$64 per adult and \$49 per child. The park made \$302 for food sales in May and June and \$408 for food sales in July and August.

May and June = $56A+21C+302$

July and August = $64A+49C+408$

Write an expression for the amount of money Get Soaked Water Park made from food and ticket sales last year.

120) Assistent #115450 "115450 - 107573 - Composition of Functions Adding (Word Problem Lvl. 2)"

The State Fair was open from May to August last year. In May and June, tickets were \$55 per adult and \$22 per child. In July and August, tickets were \$66 per adult and \$45 per child. The park made \$232 for food sales in May and June and \$568 for food sales in July and August.

May and June = $55A+22C+232$

July and August = $66A+45C+568$

Write an expression for the amount of money Get Soaked Water Park made from food and ticket sales last year.

121) Assistent #115451 "115451 - Composition of Functions Adding (Word Problem Lvl. 1)"

Dina's Boat Wash will wash boats for 19 dollars on the weekend and 33 dollars on the week day. Every day Dina spends 20 dollars for boat brushes and buckets.

Weekend = $19D - 40$

Weekday = $33D - 100$

Write an expression for the amount of money Dina will make each week.

122) Assistent #115452 "115452 - Composition of Functions Adding (Word Problem Lvl. 1)"

Betty's Dog Wash will wash dogs for 23 dollars on the weekend and 53 dollars on the week day. Every day Betty spends 29 dollars for shampoo and dog treats.

Weekend = $23D - 58$

Weekday = $53D - 145$

Write an expression for the amount of money Betty will make each week.

123) Assistent #115453 "115453 - Composition of Functions Adding (Word Problem Lvl. 1)"

Brian's Car Wash will wash cars for 32 dollars on the weekend and 37 dollars on the week day. Every day Brian spends 28 dollars for turtle wax and sponges.

Weekend = $32D - 56$

Weekday = $37D - 140$

Write an expression for the amount of money Brian will make each week.

124) Assistent #115454 "115454 - Composition of Functions Adding (Word Problem Lvl. 1)"

Candace's Bike Wash will wash bikes for 35 dollars on the weekend and 38 dollars on the week day. Every day Candace spends 29 dollars for bike shine and brushes.

Weekend = $35D - 58$

Weekday = $38D - 145$

Write an expression for the amount of money Candace will make each week.

125) Assistent #115455 "115455 - Composition of Functions Adding (Word Problem Lvl. 1)"

Carl's Dog Wash will wash dogs for 28 dollars on the weekend and 54 dollars on the week day. Every day Carl spends 21 dollars for shampoo and dog treats.

Weekend = $28D - 42$

Weekday = $54D - 105$

Write an expression for the amount of money Carl will make each week.

126) Assistent #115456 "115456 - Composition of Functions Adding (Word Problem Lvl. 1)"

Carl's Dog Wash will wash dogs for 28 dollars on the weekend and 46 dollars on the week day. Every day Carl spends 21 dollars for shampoo and dog treats.

Weekend = $28D - 42$

Weekday = $46D - 105$

Write an expression for the amount of money Carl will make each week.

127) Assistent #115457 "115457 - Composition of Functions Adding (Word Problem Lvl. 1)"

Brian's Car Wash will wash cars for 24 dollars on the weekend and 54 dollars on the week day. Every day Brian spends 20 dollars for turtle wax and sponges.

Weekend = $24D - 40$

Weekday = $54D - 100$

Write an expression for the amount of money Brian will make each week.

128) Assistent #115458 "115458 - Composition of Functions Adding (Word Problem Lvl. 1)"

Ashley's Boat Wash will wash boats for 25 dollars on the weekend and 56 dollars on the week day. Every day Ashley spends 21 dollars for boat brushes and buckets.

Weekend = $25D - 42$

Weekday = $56D - 105$

Write an expression for the amount of money Ashley will make each week.

129) Assistent #115459 "115459 - Composition of Functions Adding (Word Problem Lvl. 1)"

Ashley's Boat Wash will wash boats for 25 dollars on the weekend and 31 dollars on the week day. Every day Ashley spends 23 dollars for boat brushes and buckets.

Weekend = $25D - 46$

Weekday = $31D - 115$

Write an expression for the amount of money Ashley will make each week.

130) Assistent #115460 "115460 - Composition of Functions Adding (Word Problem Lvl. 1)"

Kevin's Car Wash will wash cars for 16 dollars on the weekend and 48 dollars on the week day. Every day Kevin spends 29 dollars for turtle wax and sponges.

Weekend = $16D - 58$

Weekday = $48D - 145$

Write an expression for the amount of money Kevin will make each week.

1) Assistent #97576 "97576 - Adding Fractions with Mixed Numbers"

What is the sum of $1 \frac{1}{5} + 1 \frac{1}{8}$?

Be sure to put a space between the whole number and the fraction in your answer. For example the answer should look like this: 6 2/3. Not like this: 62/3

2) Assistent #97577 "97577 - Adding Fractions with Mixed Numbers"

What is the sum of $1 \frac{2}{6} + 2 \frac{2}{7}$?

Be sure to put a space between the whole number and the fraction in your answer. For example the answer should look like this: 6 2/3. Not like this: 62/3

3) Assistent #97578 "97578 - Adding Fractions with Mixed Numbers"

What is the sum of $4 \frac{1}{5} + 3 \frac{1}{6}$?

Be sure to put a space between the whole number and the fraction in your answer. For example the answer should look like this: 6 2/3. Not like this: 62/3

4) Assistent #97579 "97579 - Adding Fractions with Mixed Numbers"

What is the sum of $1 \frac{2}{6} + 1 \frac{2}{8}$?

Be sure to put a space between the whole number and the fraction in your answer. For example the answer should look like this: 6 2/3. Not like this: 62/3

5) Assistent #97580 "97580 - Adding Fractions with Mixed Numbers"

What is the sum of $2 \frac{1}{2} + 1 \frac{2}{2}$?

Be sure to put a space between the whole number and the fraction in your answer. For example the answer should look like this: 6 2/3. Not like this: 62/3

6) Assistent #97581 "97581 - Adding Fractions with Mixed Numbers"

What is the sum of $3 \frac{1}{4} + 1 \frac{1}{8}$?

Be sure to put a space between the whole number and the fraction in your answer. For example the answer should look like this: 6 2/3. Not like this: 62/3

7) Assistent #97582 "97582 - Adding Fractions with Mixed Numbers"

What is the sum of $4 \frac{2}{7} + 4 \frac{1}{8}$?

Be sure to put a space between the whole number and the fraction in your answer. For example the answer should look like this: 6 2/3. Not like this: 62/3

8) Assistent #97583 "97583 - Adding Fractions with Mixed Numbers"

What is the sum of $4 \frac{1}{7} + 3 \frac{2}{9}$?

Be sure to put a space between the whole number and the fraction in your answer. For example the answer should look like this: 6 2/3. Not like this: 62/3

9) Assistent #97584 "97584 - Adding Fractions with Mixed Numbers"

What is the sum of $2 \frac{2}{5} + 3 \frac{2}{7}$?

Be sure to put a space between the whole number and the fraction in your answer. For example the answer should look like this: 6 2/3. Not like this: 62/3

10) Assistent #97585 "97585 - Adding Fractions with Mixed Numbers"

What is the sum of $2 \frac{1}{4} + 4 \frac{1}{8}$?

Be sure to put a space between the whole number and the fraction in your answer. For example the answer should look like this: 6 2/3. Not like this: 62/3

11) Assistent #97586 "97586 - Adding Fractions with Mixed Numbers"

What is the sum of $1 \frac{1}{7} + 2 \frac{2}{9}$?

Be sure to put a space between the whole number and the fraction in your answer. For example the answer should look like this: 6 2/3. Not like this: 62/3

12) Assistent #97587 "97587 - Adding Fractions with Mixed Numbers"

What is the sum of $2 \frac{1}{7} + 4 \frac{1}{8}$?

Be sure to put a space between the whole number and the fraction in your answer. For example the answer should look like this: 6 2/3. Not like this: 62/3

13) Assistent #97588 "97588 - Adding Fractions with Mixed Numbers"

What is the sum of $3 \frac{1}{5} + 3 \frac{1}{8}$?

Be sure to put a space between the whole number and the fraction in your answer. For example the answer should look like this: 6 2/3. Not like this: 62/3

14) Assistent #97589 "97589 - Adding Fractions with Mixed Numbers"

What is the sum of $3 \frac{1}{4} + 2 \frac{2}{8}$?

Be sure to put a space between the whole number and the fraction in your answer. For example the answer should look like this: 6 2/3. Not like this: 62/3

15) Assistent #97590 "97590 - Adding Fractions with Mixed Numbers"

What is the sum of $4 \frac{1}{5} + 3 \frac{2}{8}$?

Be sure to put a space between the whole number and the fraction in your answer. For example the answer should look like this: 6 2/3. Not like this: 62/3

16) Assistent #97591 "97591 - Adding Fractions with Mixed Numbers"

What is the sum of $4 \frac{1}{8} + 4 \frac{2}{9}$?

Be sure to put a space between the whole number and the fraction in your answer. For example the answer should look like this: 6 2/3. Not like this: 62/3

17) Assistent #97592 "97592 - Adding Fractions with Mixed Numbers"

What is the sum of $1 \frac{1}{4} + 1 \frac{1}{7}$?

Be sure to put a space between the whole number and the fraction in your answer. For example the answer should look like this: 6 2/3. Not like this: 62/3

18) Assistent #97593 "97593 - Adding Fractions with Mixed Numbers"

What is the sum of $4 \frac{2}{6} + 2 \frac{2}{7}$?

Be sure to put a space between the whole number and the fraction in your answer. For example the answer should look like this: 6 2/3. Not like this: 62/3

19) Assistent #97594 "97594 - Adding Fractions with Mixed Numbers"

What is the sum of $1 \frac{1}{6} + 2 \frac{1}{9}$?

Be sure to put a space between the whole number and the fraction in your answer. For example the answer should look like this: 6 2/3. Not like this: 62/3

20) Assistent #97595 "97595 - Adding Fractions with Mixed Numbers"

What is the sum of $2 \frac{2}{4} + 3 \frac{2}{8}$?

Be sure to put a space between the whole number and the fraction in your answer. For example the answer should look like this: 6 2/3. Not like this: 62/3

21) Assistent #97596 "97596 - Adding Fractions with Mixed Numbers"

What is the sum of $3 \frac{2}{4} + 2 \frac{1}{9}$?

Be sure to put a space between the whole number and the fraction in your answer. For example the answer should look like this: 6 2/3. Not like this: 62/3

22) Assistent #97597 "97597 - Adding Fractions with Mixed Numbers"

What is the sum of $4 \frac{2}{2} + 1 \frac{2}{2}$?

Be sure to put a space between the whole number and the fraction in your answer. For example the answer should look like this: 6 2/3. Not like this: 62/3

23) Assistent #97598 "97598 - Adding Fractions with Mixed Numbers"

What is the sum of $1 \frac{2}{6} + 2 \frac{2}{9}$?

Be sure to put a space between the whole number and the fraction in your answer. For example the answer should look like this: 6 2/3. Not like this: 62/3

24) Assistent #97599 "97599 - Adding Fractions with Mixed Numbers"

What is the sum of $1 \frac{2}{4} + 1 \frac{2}{7}$?

Be sure to put a space between the whole number and the fraction in your answer. For example the answer should look like this: 6 2/3. Not like this: 62/3

25) Assistent #97600 "97600 - Adding Fractions with Mixed Numbers"

What is the sum of $2 \frac{1}{4} + 1 \frac{2}{5}$?

Be sure to put a space between the whole number and the fraction in your answer. For example the answer should look like this: 6 2/3. Not like this: 62/3

26) Assistent #97601 "97601 - Adding Fractions with Mixed Numbers"

What is the sum of $1 \frac{2}{4} + 2 \frac{2}{9}$?

Be sure to put a space between the whole number and the fraction in your answer. For example the answer should look like this: 6 2/3. Not like this: 62/3

27) Assistent #97602 "97602 - Adding Fractions with Mixed Numbers"

What is the sum of $2 \frac{1}{5} + 4 \frac{1}{6}$?

Be sure to put a space between the whole number and the fraction in your answer. For example the answer should look like this: 6 2/3. Not like this: 62/3

28) Assistent #97603 "97603 - Adding Fractions with Mixed Numbers"

What is the sum of $4 \frac{1}{5} + 3 \frac{1}{9}$?

Be sure to put a space between the whole number and the fraction in your answer. For example the answer should look like this: 6 2/3. Not like this: 62/3

29) Assistent #97604 "97604 - Adding Fractions with Mixed Numbers"

What is the sum of $4 \frac{1}{6} + 2 \frac{1}{9}$?

Be sure to put a space between the whole number and the fraction in your answer. For example the answer should look like this: 6 2/3. Not like this: 62/3

30) Assistent #97605 "97605 - Adding Fractions with Mixed Numbers"

What is the sum of $2 \frac{1}{8} + 4 \frac{2}{9}$?

Be sure to put a space between the whole number and the fraction in your answer. For example the answer should look like this: 6 2/3. Not like this: 62/3

31) Assistent #97606 "97606 - Subtracting Fractions"

What is the difference of $\frac{3}{6} - \frac{2}{8}$?

32) Assistent #97607 "97607 - Subtracting Fractions"

What is the difference of $\frac{2}{5} - \frac{1}{8}$?

33) Assistent #97608 "97608 - Subtracting Fractions"

What is the difference of $\frac{2}{6} - \frac{2}{8}$?

34) Assistent #97609 "97609 - Subtracting Fractions"

What is the difference of $\frac{2}{7} - \frac{1}{9}$?

35) Assistent #97610 "97610 - Subtracting Fractions"

What is the difference of $\frac{2}{8} - \frac{2}{9}$?

36) Assistent #97611 "97611 - Subtracting Fractions"

What is the difference of $\frac{3}{5} - \frac{2}{6}$?

37) Assistent #97612 "97612 - Subtracting Fractions"

What is the difference of $\frac{2}{5} - \frac{1}{6}$?

38) Assistent #97613 "97613 - Subtracting Fractions"

What is the difference of $\frac{2}{7} - \frac{1}{8}$?

39) Assistent #97614 "97614 - Subtracting Fractions"

What is the difference of $\frac{3}{7} - \frac{1}{9}$?

40) Assistent #97615 "97615 - Subtracting Fractions"

What is the difference of $\frac{2}{6} - \frac{1}{7}$?

41) Assistent #97616 "97616 - Subtracting Fractions"

What is the difference of $\frac{2}{7} - \frac{1}{9}$?

42) Assistent #97617 "97617 - Subtracting Fractions"

What is the difference of $\frac{2}{\quad} - \frac{2}{\quad}$?

43) Assistent #97618 "97618 - Subtracting Fractions"

What is the difference of $\frac{3}{6} - \frac{2}{9}$?

44) Assistent #97619 "97619 - Subtracting Fractions"

What is the difference of $\frac{2}{5} - \frac{2}{8}$?

45) Assistent #97620 "97620 - Subtracting Fractions"

What is the difference of $\frac{2}{6} - \frac{2}{9}$?

46) Assistent #97621 "97621 - Subtracting Fractions"

What is the difference of $\frac{3}{5} - \frac{2}{8}$?

47) Assistent #97622 "97622 - Subtracting Fractions"

What is the difference of $\frac{2}{6} - \frac{1}{7}$?

48) Assistent #97623 "97623 - Subtracting Fractions"

What is the difference of $\frac{2}{6} - \frac{2}{8}$?

49) Assistent #97624 "97624 - Subtracting Fractions"

What is the difference of $\frac{3}{8} - \frac{1}{9}$?

50) Assistent #97625 "97625 - Subtracting Fractions"

What is the difference of $\frac{\quad}{7} - \frac{\quad}{9}$?

51) Assistent #97626 "97626 - Subtracting Fractions"

What is the difference of $\frac{2}{6} - \frac{2}{9}$?

52) Assistent #97627 "97627 - Subtracting Fractions"

What is the difference of $\frac{3}{8} - \frac{2}{9}$?

53) Assistent #97628 "97628 - Subtracting Fractions"

What is the difference of $\frac{3}{6} - \frac{2}{9}$?

54) Assistent #97629 "97629 - Subtracting Fractions"

What is the difference of $\frac{3}{5} - \frac{2}{7}$?

55) Assistent #97630 "97630 - Subtracting Fractions"

What is the difference of $\frac{3}{5} - \frac{1}{9}$?

56) Assistent #97631 "97631 - Subtracting Fractions"

What is the difference of $\frac{2}{7} - \frac{1}{8}$?

57) Assistent #97632 "97632 - Subtracting Fractions"

What is the difference of $\frac{2}{6} - \frac{1}{7}$?

58) Assistent #97633 "97633 - Subtracting Fractions"

What is the difference of $\frac{2}{6} - \frac{2}{8}$?

59) Assistent #97634 "97634 - Subtracting Fractions"

What is the difference of $\frac{3}{5} - \frac{1}{9}$?

60) Assistent #97635 "97635 - Subtracting Fractions"

What is the difference of $\frac{3}{5} - \frac{1}{9}$?

61) Assistent #97636 "97636 - Subtracting Fractions with Mixed Numbers"

What is the difference of $10\frac{2}{4} - 3\frac{2}{9}$?

Be sure to put a space between the whole number and the fraction in your answer. For example the answer should look like this: $6\frac{2}{3}$. Not like this: $62/3$

62) Assistent #97637 "97637 - Subtracting Fractions with Mixed Numbers"

What is the difference of $7\frac{3}{7} - 3\frac{1}{7}$?

Be sure to put a space between the whole number and the fraction in your answer. For example the answer should look like this: $6\frac{2}{3}$. Not like this: $62/3$

63) Assistent #97638 "97638 - Subtracting Fractions with Mixed Numbers"

What is the difference of $9\frac{2}{6} - 3\frac{1}{9}$?

Be sure to put a space between the whole number and the fraction in your answer. For example the answer should look like this: $6\frac{2}{3}$. Not like this: $62/3$

64) Assistent #97639 "97639 - Subtracting Fractions with Mixed Numbers"

What is the difference of $11\frac{3}{4} - 3\frac{2}{8}$?

Be sure to put a space between the whole number and the fraction in your answer. For

example the answer should look like this: $6 \frac{2}{3}$. Not like this: $62/3$

65) Assistent #97640 "97640 - Subtracting Fractions with Mixed Numbers"

What is the difference of $11 \frac{2}{4} - 3 \frac{1}{9}$?

Be sure to put a space between the whole number and the fraction in your answer. For example the answer should look like this: $6 \frac{2}{3}$. Not like this: $62/3$

66) Assistent #97641 "97641 - Subtracting Fractions with Mixed Numbers"

What is the difference of $10 \frac{3}{8} - 2 \frac{1}{9}$?

Be sure to put a space between the whole number and the fraction in your answer. For example the answer should look like this: $6 \frac{2}{3}$. Not like this: $62/3$

67) Assistent #97642 "97642 - Subtracting Fractions with Mixed Numbers"

What is the difference of $11 \frac{3}{7} - 1 \frac{1}{9}$?

Be sure to put a space between the whole number and the fraction in your answer. For example the answer should look like this: $6 \frac{2}{3}$. Not like this: $62/3$

68) Assistent #97643 "97643 - Subtracting Fractions with Mixed Numbers"

What is the difference of $7 \frac{2}{5} - 1 \frac{2}{6}$?

Be sure to put a space between the whole number and the fraction in your answer. For example the answer should look like this: $6 \frac{2}{3}$. Not like this: $62/3$

69) Assistent #97644 "97644 - Subtracting Fractions with Mixed Numbers"

What is the difference of $12 \frac{2}{4} - 2 \frac{2}{5}$?

Be sure to put a space between the whole number and the fraction in your answer. For example the answer should look like this: $6 \frac{2}{3}$. Not like this: $62/3$

70) Assistent #97645 "97645 - Subtracting Fractions with Mixed Numbers"

$\frac{3}{\quad} - \frac{2}{\quad}$

What is the difference of $9 \frac{\quad}{8} - 1 \frac{\quad}{6}$?

Be sure to put a space between the whole number and the fraction in your answer. For example the answer should look like this: $6 \frac{2}{3}$. Not like this: $62/3$

71) Assistent #97646 "97646 - Subtracting Fractions with Mixed Numbers"

What is the difference of $11 \frac{3}{4} - 2 \frac{2}{8}$?

Be sure to put a space between the whole number and the fraction in your answer. For example the answer should look like this: $6 \frac{2}{3}$. Not like this: $62/3$

72) Assistent #97647 "97647 - Subtracting Fractions with Mixed Numbers"

What is the difference of $10 \frac{2}{5} - 1 \frac{2}{8}$?

Be sure to put a space between the whole number and the fraction in your answer. For example the answer should look like this: $6 \frac{2}{3}$. Not like this: $62/3$

73) Assistent #97648 "97648 - Subtracting Fractions with Mixed Numbers"

What is the difference of $6 \frac{2}{7} - 1 \frac{2}{7}$?

Be sure to put a space between the whole number and the fraction in your answer. For example the answer should look like this: $6 \frac{2}{3}$. Not like this: $62/3$

74) Assistent #97649 "97649 - Subtracting Fractions with Mixed Numbers"

What is the difference of $6 \frac{2}{4} - 2 \frac{1}{8}$?

Be sure to put a space between the whole number and the fraction in your answer. For example the answer should look like this: $6 \frac{2}{3}$. Not like this: $62/3$

75) Assistent #97650 "97650 - Subtracting Fractions with Mixed Numbers"

What is the difference of $10 \frac{3}{8} - 1 \frac{1}{9}$?

Be sure to put a space between the whole number and the fraction in your answer. For example the answer should look like this: $6 \frac{2}{3}$. Not like this: $62/3$

76) Assistent #97651 "97651 - Subtracting Fractions with Mixed Numbers"

What is the difference of $9 \frac{2}{7} - 1 \frac{2}{8}$?

Be sure to put a space between the whole number and the fraction in your answer. For example the answer should look like this: $6 \frac{2}{3}$. Not like this: $62/3$

77) Assistent #97652 "97652 - Subtracting Fractions with Mixed Numbers"

What is the difference of $11 \frac{3}{7} - 3 \frac{1}{6}$?

Be sure to put a space between the whole number and the fraction in your answer. For example the answer should look like this: $6 \frac{2}{3}$. Not like this: $62/3$

78) Assistent #97653 "97653 - Subtracting Fractions with Mixed Numbers"

What is the difference of $10 \frac{3}{4} - 2 \frac{2}{8}$?

Be sure to put a space between the whole number and the fraction in your answer. For example the answer should look like this: $6 \frac{2}{3}$. Not like this: $62/3$

79) Assistent #97654 "97654 - Subtracting Fractions with Mixed Numbers"

What is the difference of $12 \frac{3}{7} - 2 \frac{2}{9}$?

Be sure to put a space between the whole number and the fraction in your answer. For example the answer should look like this: $6 \frac{2}{3}$. Not like this: $62/3$

80) Assistent #97655 "97655 - Subtracting Fractions with Mixed Numbers"

What is the difference of $11 \frac{2}{5} - 2 \frac{2}{9}$?

Be sure to put a space between the whole number and the fraction in your answer. For example the answer should look like this: $6 \frac{2}{3}$. Not like this: $62/3$

81) Assistent #97656 "97656 - Subtracting Fractions with Mixed Numbers"

What is the difference of $5 \frac{2}{4} - 2 \frac{1}{8}$?

Be sure to put a space between the whole number and the fraction in your answer. For example the answer should look like this: $6 \frac{2}{3}$. Not like this: $62/3$

82) Assistent #97657 "97657 - Subtracting Fractions with Mixed Numbers"

What is the difference of $7 \frac{3}{5} - 1 \frac{1}{6}$?

Be sure to put a space between the whole number and the fraction in your answer. For example the answer should look like this: $6 \frac{2}{3}$. Not like this: $62/3$

83) Assistent #97658 "97658 - Subtracting Fractions with Mixed Numbers"

What is the difference of $5 \frac{3}{6} - 2 \frac{1}{6}$?

Be sure to put a space between the whole number and the fraction in your answer. For example the answer should look like this: $6 \frac{2}{3}$. Not like this: $62/3$

84) Assistent #97659 "97659 - Subtracting Fractions with Mixed Numbers"

What is the difference of $5 \frac{3}{6} - 1 \frac{2}{6}$?

Be sure to put a space between the whole number and the fraction in your answer. For example the answer should look like this: $6 \frac{2}{3}$. Not like this: $62/3$

85) Assistent #97660 "97660 - Subtracting Fractions with Mixed Numbers"

What is the difference of $11 \frac{2}{5} - 2 \frac{1}{5}$?

Be sure to put a space between the whole number and the fraction in your answer. For example the answer should look like this: $6 \frac{2}{3}$. Not like this: $62/3$

86) Assistent #97661 "97661 - Subtracting Fractions with Mixed Numbers"

What is the difference of $12 \frac{2}{4} - 1 \frac{1}{7}$?

Be sure to put a space between the whole number and the fraction in your answer. For example the answer should look like this: $6 \frac{2}{3}$. Not like this: $62/3$

87) Assistent #97662 "97662 - Subtracting Fractions with Mixed Numbers"

What is the difference of $8 \frac{3}{6} - 1 \frac{1}{8}$?

Be sure to put a space between the whole number and the fraction in your answer. For example the answer should look like this: $6 \frac{2}{3}$. Not like this: $62/3$

88) Assistent #97663 "97663 - Subtracting Fractions with Mixed Numbers"

What is the difference of $7 \frac{3}{4} - 2 \frac{2}{9}$?

Be sure to put a space between the whole number and the fraction in your answer. For example the answer should look like this: $6 \frac{2}{3}$. Not like this: $62/3$

89) Assistent #97664 "97664 - Subtracting Fractions with Mixed Numbers"

What is the difference of $8 \frac{3}{6} - 1 \frac{1}{8}$?

Be sure to put a space between the whole number and the fraction in your answer. For example the answer should look like this: $6 \frac{2}{3}$. Not like this: $62/3$

90) Assistent #97665 "97665 - Subtracting Fractions with Mixed Numbers"

What is the difference of $6 \frac{2}{6} - 1 \frac{2}{8}$?

Be sure to put a space between the whole number and the fraction in your answer. For example the answer should look like this: $6 \frac{2}{3}$. Not like this: $62/3$

91) Assistent #97666 "97666 - Adding Fractions"

What is the sum of $\frac{2}{8} + \frac{1}{9}$?

92) Assistent #97667 "97667 - Adding Fractions"

What is the sum of $\frac{3}{7} + \frac{2}{8}$?

93) Assistent #97668 "97668 - Adding Fractions"

94) Assistent #97669 "97669 - Adding Fractions"

What is the sum of $\frac{2}{5} + \frac{1}{6}$?

95) Assistent #97670 "97670 - Adding Fractions"

What is the sum of $\frac{1}{7} + \frac{3}{8}$?

96) Assistent #97671 "97671 - Adding Fractions"

What is the sum of $\frac{3}{7} + \frac{2}{8}$?

97) Assistent #97672 "97672 - Adding Fractions"

What is the sum of $\frac{2}{6} + \frac{3}{7}$?

98) Assistent #97673 "97673 - Adding Fractions"

What is the sum of $\frac{2}{5} + \frac{1}{8}$?

99) Assistent #97674 "97674 - Adding Fractions"

What is the sum of $\frac{2}{5} + \frac{2}{7}$?

101) Assistent #97676 "97676 - Adding Fractions"

What is the sum of $\frac{1}{8} + \frac{2}{9}$?

102) Assistent #97677 "97677 - Adding Fractions"

What is the sum of $\frac{2}{6} + \frac{1}{8}$?

103) Assistent #97678 "97678 - Adding Fractions"

What is the sum of $\frac{1}{7} + \frac{1}{8}$?

104) Assistent #97679 "97679 - Adding Fractions"

What is the sum of $\frac{2}{5} + \frac{3}{8}$?

105) Assistent #97680 "97680 - Adding Fractions"

What is the sum of $\frac{3}{5} + \frac{2}{6}$?

106) Assistent #97681 "97681 - Adding Fractions"

What is the sum of $\frac{3}{6} + \frac{2}{9}$?

108) Assistent #97683 "97683 - Adding Fractions"

What is the sum of $\frac{3}{6} + \frac{2}{8}$?

109) Assistent #97684 "97684 - Adding Fractions"

What is the sum of $\frac{1}{6} + \frac{3}{7}$?

110) Assistent #97685 "97685 - Adding Fractions"

What is the sum of $\frac{2}{5} + \frac{1}{7}$?

111) Assistent #97686 "97686 - Adding Fractions"

What is the sum of $\frac{2}{5} + \frac{2}{6}$?

112) Assistent #97687 "97687 - Adding Fractions"

What is the sum of $\frac{2}{5} + \frac{3}{6}$?

113) Assistent #97688 "97688 - Adding Fractions"

What is the sum of $\frac{3}{6} + \frac{2}{9}$?

114) Assistent #97689 "97689 - Adding Fractions"

115) Assistentment #97690 "97690 - Adding Fractions"

What is the sum of $\frac{1}{6} + \frac{3}{8}$?

116) Assistentment #97691 "97691 - Adding Fractions"

What is the sum of $\frac{2}{7} + \frac{2}{9}$?

117) Assistentment #97692 "97692 - Adding Fractions"

What is the sum of $\frac{3}{5} + \frac{3}{7}$?

118) Assistentment #97693 "97693 - Adding Fractions"

What is the sum of $\frac{3}{6} + \frac{3}{8}$?

119) Assistentment #97694 "97694 - Adding Fractions"

What is the sum of $\frac{3}{8} + \frac{2}{9}$?

120) Assistentment #97695 "97695 - Adding Fractions"

What is the sum of $\frac{1}{5} + \frac{3}{7}$?

Problem Set 11829 "Multiplication Fractions - THE SKILL BUILDING SET" id:[11829]

1) Assistent #48168 "48168 - Multiplying Fractions"

What is the product of $\frac{1}{8} \times \frac{7}{5}$?

2) Assistent #48169 "48169 - Multiplying Fractions"

What is the product of $\frac{3}{9} \times \frac{1}{2}$?

3) Assistent #48170 "48170 - Multiplying Fractions"

What is the product of $\frac{5}{4} \times \frac{8}{2}$?

4) Assistent #48171 "48171 - Multiplying Fractions"

What is the product of $\frac{6}{2} \times \frac{3}{4}$?

5) Assistent #48172 "48172 - Multiplying Fractions"

What is the product of $\frac{6}{4} \times \frac{4}{6}$?

6) Assistent #48173 "48173 - Multiplying Fractions"

What is the product of $\frac{4}{5} \times \frac{5}{5}$?

7) Assistent #48174 "48174 - Multiplying Fractions"

What is the product of $\frac{8}{2} \times \frac{7}{6}$?

8) Assistent #48175 "48175 - Multiplying Fractions"

What is the product of $\frac{3}{2} \times \frac{5}{2}$?

9) Assistent #48176 "48176 - Multiplying Fractions"

What is the product of $\frac{5}{7} \times \frac{5}{4}$?

10) Assistent #48177 "48177 - Multiplying Fractions"

What is the product of $\frac{6}{4} \times \frac{9}{7}$?

11) Assistent #48178 "48178 - Multiplying Fractions"

What is the product of $\frac{7}{1} \times \frac{9}{1}$?

12) Assistent #48179 "48179 - Multiplying Fractions"

What is the product of $\frac{7}{5} \times \frac{3}{4}$?

13) Assistent #48180 "48180 - Multiplying Fractions"

$\frac{5}{4}$

What is the product of $\frac{\quad}{6} \times \frac{\quad}{2}$?

14) Assistent #48181 "48181 - Multiplying Fractions"

What is the product of $\frac{8}{5} \times \frac{3}{4}$?

15) Assistent #48182 "48182 - Multiplying Fractions"

What is the product of $\frac{5}{9} \times \frac{7}{5}$?

16) Assistent #48183 "48183 - Multiplying Fractions"

What is the product of $\frac{4}{8} \times \frac{4}{8}$?

17) Assistent #48184 "48184 - Multiplying Fractions"

What is the product of $\frac{7}{2} \times \frac{8}{3}$?

18) Assistent #48185 "48185 - Multiplying Fractions"

What is the product of $\frac{3}{6} \times \frac{7}{3}$?

19) Assistent #48186 "48186 - Multiplying Fractions"

What is the product of $\frac{9}{9} \times \frac{7}{6}$?

20) Assistent #48187 "48187 - Multiplying Fractions"

21) Assistent #48188 "48188 - Multiplying Fractions"

What is the product of $\frac{4}{4} \times \frac{6}{1}$?

22) Assistent #48189 "48189 - Multiplying Fractions"

What is the product of $\frac{8}{4} \times \frac{6}{3}$?

23) Assistent #48190 "48190 - Multiplying Fractions"

What is the product of $\frac{8}{1} \times \frac{2}{7}$?

24) Assistent #48191 "48191 - Multiplying Fractions"

What is the product of $\frac{5}{9} \times \frac{4}{6}$?

25) Assistent #48192 "48192 - Multiplying Fractions"

What is the product of $\frac{8}{5} \times \frac{4}{8}$?

26) Assistent #48193 "48193 - Multiplying Fractions"

What is the product of $\frac{6}{3} \times \frac{1}{6}$?

27) Assistent #48194 "48194 - Multiplying Fractions"

What is the product of $\frac{1}{7} \times \frac{7}{7}$?

28) Assistent #48195 "48195 - Multiplying Fractions"

What is the product of $\frac{8}{7} \times \frac{9}{6}$?

29) Assistent #48196 "48196 - Multiplying Fractions"

What is the product of $\frac{2}{4} \times \frac{5}{5}$?

30) Assistent #48197 "48197 - Multiplying Fractions"

What is the product of $\frac{1}{2} \times \frac{5}{9}$?

31) Assistent #48269 "48269 - Multiplying Fractions with Mixed Numbers"

What is the product of $1 \frac{1}{2} \times \frac{1}{2}$?

You MUST reduce your answer to lowest terms.

If your answer is a mixed number, be sure to put a space between the whole number and the fraction in your answer. The answer should look like this: $6 \frac{2}{3}$. Not like this: $62/3$

32) Assistent #48270 "48270 - Multiplying Fractions with Mixed Numbers"

What is the product of $1 \frac{1}{3} \times \frac{1}{3}$?

You MUST reduce your answer to lowest terms.

If your answer is a mixed number, be sure to put a space between the whole number and the fraction in your answer. The answer should look like this: $6 \frac{2}{3}$. Not like this: $62/3$

33) Assistent #48271 "48271 - Multiplying Fractions with Mixed Numbers"

What is the product of $1 \frac{1}{4} \times \frac{1}{4}$?

You MUST reduce your answer to lowest terms.

If your answer is a mixed number, be sure to put a space between the whole number and the fraction in your answer. The answer should look like this: $6 \frac{2}{3}$. Not like this: $62/3$

34) Assistent #48272 "48272 - Multiplying Fractions with Mixed Numbers"

What is the product of $1 \frac{1}{5} \times \frac{1}{5}$?

You MUST reduce your answer to lowest terms.

If your answer is a mixed number, be sure to put a space between the whole number and the fraction in your answer. The answer should look like this: $6 \frac{2}{3}$. Not like this: $62/3$

35) Assistent #48273 "48273 - Multiplying Fractions with Mixed Numbers"

What is the product of $1 \frac{2}{3} \times \frac{1}{6}$?

You MUST reduce your answer to lowest terms.

If your answer is a mixed number, be sure to put a space between the whole number and the fraction in your answer. The answer should look like this: $6 \frac{2}{3}$. Not like this: $62/3$

36) Assistent #48274 "48274 - Multiplying Fractions with Mixed Numbers"

What is the product of $1 \frac{2}{5} \times \frac{1}{7}$?

You MUST reduce your answer to lowest terms.

If your answer is a mixed number, be sure to put a space between the whole number and the fraction in your answer. The answer should look like this: $6 \frac{2}{3}$. Not like this: $62/3$

37) Assistent #48275 "48275 - Multiplying Fractions with Mixed Numbers"

What is the product of $1 \frac{3}{4} \times \frac{1}{8}$?

You MUST reduce your answer to lowest terms.

If your answer is a mixed number, be sure to put a space between the whole number and the fraction in your answer. The answer should look like this: $6 \frac{2}{3}$. Not like this: $62/3$

38) Assistent #48276 "48276 - Multiplying Fractions with Mixed Numbers"

What is the product of $1 \frac{3}{5} \times \frac{1}{9}$?

You MUST reduce your answer to lowest terms.

If your answer is a mixed number, be sure to put a space between the whole number and the fraction in your answer. The answer should look like this: $6 \frac{2}{3}$. Not like this: $62/3$

39) Assistent #48277 "48277 - Multiplying Fractions with Mixed Numbers"

What is the product of $1 \frac{4}{5} \times \frac{1}{10}$?

You MUST reduce your answer to lowest terms.

If your answer is a mixed number, be sure to put a space between the whole number and the fraction in your answer. The answer should look like this: $6 \frac{2}{3}$. Not like this: $62/3$

40) Assistent #48278 "48278 - Multiplying Fractions with Mixed Numbers"

What is the product of $2 \frac{1}{2} \times \frac{1}{11}$?

You MUST reduce your answer to lowest terms.

If your answer is a mixed number, be sure to put a space between the whole number and the fraction in your answer. The answer should look like this: $6 \frac{2}{3}$. Not like this: $62/3$

41) Assistent #48279 "48279 - Multiplying Fractions with Mixed Numbers"

What is the product of $1 \frac{1}{2} \times \frac{1}{2}$?

You MUST reduce your answer to lowest terms.

If your answer is a mixed number, be sure to put a space between the whole number and the fraction in your answer. The answer should look like this: $6 \frac{2}{3}$. Not like this: $62/3$

42) Assistent #48280 "48280 - Multiplying Fractions with Mixed Numbers"

What is the product of $1 \frac{1}{3} \times \frac{1}{3}$?

You MUST reduce your answer to lowest terms.

If your answer is a mixed number, be sure to put a space between the whole number and the fraction in your answer. The answer should look like this: $6 \frac{2}{3}$. Not like this: $62/3$

43) Assistent #48281 "48281 - Multiplying Fractions with Mixed Numbers"

What is the product of $1 \frac{1}{4} \times \frac{1}{4}$?

You MUST reduce your answer to lowest terms.

If your answer is a mixed number, be sure to put a space between the whole number and the fraction in your answer. The answer should look like this: $6 \frac{2}{3}$. Not like this: $62/3$

44) Assistent #48282 "48282 - Multiplying Fractions with Mixed Numbers"

What is the product of $1 \frac{1}{5} \times \frac{1}{5}$?

You MUST reduce your answer to lowest terms.

If your answer is a mixed number, be sure to put a space between the whole number and the fraction in your answer. The answer should look like this: $6 \frac{2}{3}$. Not like this: $62/3$

45) Assistent #48283 "48283 - Multiplying Fractions with Mixed Numbers"

What is the product of $1 \frac{2}{3} \times \frac{1}{6}$?

You MUST reduce your answer to lowest terms.

If your answer is a mixed number, be sure to put a space between the whole number and the fraction in your answer. The answer should look like this: $6 \frac{2}{3}$. Not like this: $62/3$

46) Assistent #48284 "48284 - Multiplying Fractions with Mixed Numbers"

$2 \frac{1}{2}$

What is the product of $1 \frac{\quad}{5} \times \frac{\quad}{7}$?

You MUST reduce your answer to lowest terms.

If your answer is a mixed number, be sure to put a space between the whole number and the fraction in your answer. The answer should look like this: $6 \frac{2}{3}$. Not like this: $62/3$

47) Assistent #48285 "48285 - Multiplying Fractions with Mixed Numbers"

What is the product of $1 \frac{3}{4} \times \frac{1}{8}$?

You MUST reduce your answer to lowest terms.

If your answer is a mixed number, be sure to put a space between the whole number and the fraction in your answer. The answer should look like this: $6 \frac{2}{3}$. Not like this: $62/3$

48) Assistent #48286 "48286 - Multiplying Fractions with Mixed Numbers"

What is the product of $1 \frac{3}{5} \times \frac{1}{9}$?

You MUST reduce your answer to lowest terms.

If your answer is a mixed number, be sure to put a space between the whole number and the fraction in your answer. The answer should look like this: $6 \frac{2}{3}$. Not like this: $62/3$

49) Assistent #48287 "48287 - Multiplying Fractions with Mixed Numbers"

What is the product of $1 \frac{4}{5} \times \frac{1}{10}$?

You MUST reduce your answer to lowest terms.

If your answer is a mixed number, be sure to put a space between the whole number and the fraction in your answer. The answer should look like this: $6 \frac{2}{3}$. Not like this: $62/3$

50) Assistent #48288 "48288 - Multiplying Fractions with Mixed Numbers"

What is the product of $2 \frac{1}{2} \times \frac{1}{11}$?

You MUST reduce your answer to lowest terms.

If your answer is a mixed number, be sure to put a space between the whole number and the fraction in your answer. The answer should look like this: 6 2/3. Not like this: 62/3

51) Assistent #48290 "48290 - Multiplying Fractions with Mixed Numbers"

What is the product of $1 \frac{1}{2} \times \frac{1}{2}$?

You MUST reduce your answer to lowest terms.

If your answer is a mixed number, be sure to put a space between the whole number and the fraction in your answer. The answer should look like this: 6 2/3. Not like this: 62/3

52) Assistent #48291 "48291 - Multiplying Fractions with Mixed Numbers"

What is the product of $1 \frac{1}{3} \times \frac{1}{3}$?

You MUST reduce your answer to lowest terms.

If your answer is a mixed number, be sure to put a space between the whole number and the fraction in your answer. The answer should look like this: 6 2/3. Not like this: 62/3

53) Assistent #48292 "48292 - Multiplying Fractions with Mixed Numbers"

What is the product of $1 \frac{1}{4} \times \frac{1}{4}$?

You MUST reduce your answer to lowest terms.

If your answer is a mixed number, be sure to put a space between the whole number and the fraction in your answer. The answer should look like this: 6 2/3. Not like this: 62/3

54) Assistent #48293 "48293 - Multiplying Fractions with Mixed Numbers"

What is the product of $1 \frac{1}{5} \times \frac{1}{5}$?

You MUST reduce your answer to lowest terms.

If your answer is a mixed number, be sure to put a space between the whole number and the fraction in your answer. The answer should look like this: 6 2/3. Not like this: 62/3

55) Assistent #48294 "48294 - Multiplying Fractions with Mixed Numbers"

What is the product of $1 \frac{2}{3} \times \frac{1}{6}$?

You MUST reduce your answer to lowest terms.

If your answer is a mixed number, be sure to put a space between the whole number and the fraction in your answer. The answer should look like this: $6 \frac{2}{3}$. Not like this: $62/3$

56) Assistent #48295 "48295 - Multiplying Fractions with Mixed Numbers"

What is the product of $1 \frac{2}{5} \times \frac{1}{7}$?

You MUST reduce your answer to lowest terms.

If your answer is a mixed number, be sure to put a space between the whole number and the fraction in your answer. The answer should look like this: $6 \frac{2}{3}$. Not like this: $62/3$

57) Assistent #48296 "48296 - Multiplying Fractions with Mixed Numbers"

What is the product of $1 \frac{3}{4} \times \frac{1}{8}$?

You MUST reduce your answer to lowest terms.

If your answer is a mixed number, be sure to put a space between the whole number and the fraction in your answer. The answer should look like this: $6 \frac{2}{3}$. Not like this: $62/3$

58) Assistent #48297 "48297 - Multiplying Fractions with Mixed Numbers"

What is the product of $1 \frac{3}{5} \times \frac{1}{9}$?

You MUST reduce your answer to lowest terms.

If your answer is a mixed number, be sure to put a space between the whole number and the fraction in your answer. The answer should look like this: $6 \frac{2}{3}$. Not like this: $62/3$

59) Assistent #48298 "48298 - Multiplying Fractions with Mixed Numbers"

What is the product of $1 \frac{4}{5} \times \frac{1}{10}$?

You MUST reduce your answer to lowest terms.

If your answer is a mixed number, be sure to put a space between the whole number and the fraction in your answer. The answer should look like this: 6 $\frac{2}{3}$. Not like this: $\frac{62}{3}$

60) Assisment #48299 "48299 - Multiplying Fractions with Mixed Numbers"

What is the product of $2\frac{1}{2}$ x $\frac{1}{11}$?

You MUST reduce your answer to lowest terms.

If your answer is a mixed number, be sure to put a space between the whole number and the fraction in your answer. The answer should look like this: 6 $\frac{2}{3}$. Not like this: $\frac{62}{3}$

Problem Set 6917 "Dividing Fractions" id:[6917]

1) Assistent #48411 "48411 - Dividing Fracitons"

What is the quotient of $\frac{1}{7} \div \frac{9}{6}$?

2) Assistent #48412 "48412 - Dividing Fracitons"

What is the quotient of $\frac{6}{3} \div \frac{9}{1}$?

3) Assistent #48413 "48413 - Dividing Fracitons"

What is the quotient of $\frac{3}{2} \div \frac{1}{5}$?

4) Assistent #48414 "48414 - Dividing Fracitons"

What is the quotient of $\frac{1}{5} \div \frac{5}{6}$?

5) Assistent #48415 "48415 - Dividing Fracitons"

What is the quotient of $\frac{1}{3} \div \frac{6}{3}$?

6) Assistent #48416 "48416 - Dividing Fracitons"

What is the quotient of $\frac{6}{2} \div \frac{4}{7}$?

7) Assistent #48417 "48417 - Dividing Fracitons"

What is the quotient of $\frac{5}{1} \div \frac{7}{2}$?

8) Assistent #48418 "48418 - Dividing Fracitons"

What is the quotient of $\frac{1}{7} \div \frac{6}{8}$?

9) Assistent #48419 "48419 - Dividing Fracitons"

What is the quotient of $\frac{8}{1} \div \frac{5}{8}$?

10) Assistent #48420 "48420 - Dividing Fracitons"

What is the quotient of $\frac{9}{1} \div \frac{5}{3}$?

11) Assistent #48421 "48421 - Dividing Fracitons"

What is the quotient of $\frac{4}{2} \div \frac{7}{5}$?

12) Assistent #48422 "48422 - Dividing Fracitons"

What is the quotient of $\frac{9}{6} \div \frac{8}{6}$?

13) Assistent #48423 "48423 - Dividing Fracitons"

What is the quotient of $\frac{6}{4} \div \frac{2}{3}$?

14) Assistent #48424 "48424 - Dividing Fracitons"

What is the quotient of $\frac{2}{9} \div \frac{3}{4}$?

15) Assistent #48425 "48425 - Dividing Fracitons"

What is the quotient of $\frac{3}{9} \div \frac{6}{2}$?

16) Assistent #48426 "48426 - Dividing Fracitons"

What is the quotient of $\frac{7}{3} \div \frac{1}{1}$?

17) Assistent #48427 "48427 - Dividing Fracitons"

What is the quotient of $\frac{1}{3} \div \frac{9}{9}$?

18) Assistent #48428 "48428 - Dividing Fracitons"

$\frac{4}{\quad} \div \frac{3}{\quad}$

What is the quotient of $\frac{\quad}{5} \div \frac{\quad}{8}$?

19) Assistent #48429 "48429 - Dividing Fracitons"

What is the quotient of $\frac{7}{2} \div \frac{2}{4}$?

20) Assistent #48430 "48430 - Dividing Fracitons"

What is the quotient of $\frac{5}{6} \div \frac{3}{4}$?

21) Assistent #48431 "48431 - Dividing Fracitons"

What is the quotient of $\frac{7}{4} \div \frac{2}{3}$?

22) Assistent #48432 "48432 - Dividing Fracitons"

What is the quotient of $\frac{8}{5} \div \frac{4}{2}$?

23) Assistent #48433 "48433 - Dividing Fracitons"

What is the quotient of $\frac{4}{5} \div \frac{1}{8}$?

24) Assistent #48434 "48434 - Dividing Fracitons"

What is the quotient of $\frac{4}{7} \div \frac{7}{6}$?

25) Assistent #48435 "48435 - Dividing Fracitons"

What is the quotient of $\frac{6}{2} \div \frac{7}{8}$?

26) Assistent #48436 "48436 - Dividing Fracitons"

What is the quotient of $\frac{3}{5} \div \frac{3}{8}$?

27) Assistent #48437 "48437 - Dividing Fracitons"

What is the quotient of $\frac{9}{3} \div \frac{8}{2}$?

28) Assistent #48438 "48438 - Dividing Fracitons"

What is the quotient of $\frac{6}{1} \div \frac{4}{4}$?

29) Assistent #48439 "48439 - Dividing Fracitons"

What is the quotient of $\frac{6}{5} \div \frac{6}{4}$?

30) Assistent #48440 "48440 - Dividing Fracitons"

What is the quotient of $\frac{5}{3} \div \frac{7}{5}$?

31) Assistent #48441 "48441 - Dividing Fracitons"

What is the quotient of $\frac{4}{4} \div \frac{7}{7}$?

32) Assistent #48442 "48442 - Dividing Fracitons"

What is the quotient of $\frac{4}{8} \div \frac{5}{4}$?

33) Assistent #48443 "48443 - Dividing Fracitons"

What is the quotient of $\frac{9}{4} \div \frac{2}{7}$?

34) Assistent #48444 "48444 - Dividing Fracitons"

What is the quotient of $\frac{9}{3} \div \frac{9}{1}$?

35) Assistent #48445 "48445 - Dividing Fracitons"

What is the quotient of $\frac{1}{1} \div \frac{2}{5}$?

36) Assistent #48446 "48446 - Dividing Fracitons"

What is the quotient of $\frac{4}{5} \div \frac{6}{5}$?

37) Assistent #48447 "48447 - Dividing Fracitons"

What is the quotient of $\frac{4}{9} \div \frac{3}{9}$?

38) Assistent #48448 "48448 - Dividing Fracitons"

What is the quotient of $\frac{1}{1} \div \frac{9}{7}$?

39) Assistent #48449 "48449 - Dividing Fracitons"

What is the quotient of $\frac{2}{9} \div \frac{9}{9}$?

40) Assistent #48450 "48450 - Dividing Fracitons"

What is the quotient of $\frac{3}{7} \div \frac{9}{4}$?

41) Assistent #48451 "48451 - Dividing Fracitons"

What is the quotient of $\frac{2}{1} \div \frac{2}{2}$?

42) Assistent #48452 "48452 - Dividing Fracitons"

What is the quotient of $\frac{1}{2} \div \frac{9}{1}$?

43) Assistent #48453 "48453 - Dividing Fracitons"

What is the quotient of $\frac{\quad}{8} \div \frac{\quad}{8}$?

44) Assistent #48454 "48454 - Dividing Fracitons"

What is the quotient of $\frac{8}{9} \div \frac{3}{7}$?

45) Assistent #48455 "48455 - Dividing Fracitons"

What is the quotient of $\frac{7}{3} \div \frac{3}{1}$?

46) Assistent #48456 "48456 - Dividing Fracitons"

What is the quotient of $\frac{3}{3} \div \frac{6}{8}$?

47) Assistent #48457 "48457 - Dividing Fracitons"

What is the quotient of $\frac{5}{7} \div \frac{7}{2}$?

48) Assistent #48458 "48458 - Dividing Fracitons"

What is the quotient of $\frac{5}{4} \div \frac{7}{1}$?

49) Assistent #48459 "48459 - Dividing Fracitons"

What is the quotient of $\frac{7}{\quad} \div \frac{2}{\quad}$?

50) Assisment #48460 "48460 - Dividing Fracitons"

What is the quotient of $\frac{6}{5} \div \frac{5}{7}$?

51) Assisment #48461 "48461 - Dividing Fractions with Mixed Numbers"

What is the quotient of $1 \frac{1}{2} \div \frac{1}{2}$?

You MUST reduce your answer to lowest terms.

If your answer is a mixed number, be sure to put a space between the whole number and the fraction in your answer. The answer should look like this: $6 \frac{2}{3}$. Not like this: $62/3$

52) Assisment #8462 "8462 - 2004 Retest 6 10G Nov"

What is the quotient of $2 \frac{1}{6} \div \frac{1}{6}$?

You MUST reduce your answer to lowest terms.

If your answer is a mixed number, be sure to put a space between the whole number and the fraction in your answer. The answer should look like this: $6 \frac{2}{3}$. Not like this: $62/3$

53) Assisment #8463 "8463 - 2004 Retest 7 10G Nov"

What is the quotient of $1 \frac{1}{4} \div \frac{1}{4}$?

You MUST reduce your answer to lowest terms.

If your answer is a mixed number, be sure to put a space between the whole number and the fraction in your answer. The answer should look like this: $6 \frac{2}{3}$. Not like this: $62/3$

54) Assisment #48464 "48464 - Dividing Fractions with Mixed Numbers"

What is the quotient of $1 \frac{1}{5} \div \frac{1}{5}$?

You MUST reduce your answer to lowest terms.

If your answer is a mixed number, be sure to put a space between the whole number and the fraction in your answer. The answer should look like this: $6 \frac{2}{3}$. Not like this: $62/3$

55) Assistent #48465 "48465 - Dividing Fractions with Mixed Numbers"

What is the quotient of $1 \frac{2}{3} \div \frac{1}{6}$?

You MUST reduce your answer to lowest terms.

If your answer is a mixed number, be sure to put a space between the whole number and the fraction in your answer. The answer should look like this: $6 \frac{2}{3}$. Not like this: $62/3$

56) Assistent #48466 "48466 - Dividing Fractions with Mixed Numbers"

What is the quotient of $1 \frac{2}{5} \div \frac{1}{7}$?

You MUST reduce your answer to lowest terms.

If your answer is a mixed number, be sure to put a space between the whole number and the fraction in your answer. The answer should look like this: $6 \frac{2}{3}$. Not like this: $62/3$

57) Assistent #48467 "48467 - Dividing Fractions with Mixed Numbers"

What is the quotient of $1 \frac{3}{4} \div \frac{1}{8}$?

You MUST reduce your answer to lowest terms.

If your answer is a mixed number, be sure to put a space between the whole number and the fraction in your answer. The answer should look like this: $6 \frac{2}{3}$. Not like this: $62/3$

58) Assistent #48468 "48468 - Dividing Fractions with Mixed Numbers"

What is the quotient of $1 \frac{3}{5} \div \frac{1}{9}$?

You MUST reduce your answer to lowest terms.

If your answer is a mixed number, be sure to put a space between the whole number and the fraction in your answer. The answer should look like this: $6 \frac{2}{3}$. Not like this: $62/3$

59) Assistent #48469 "48469 - Dividing Fractions with Mixed Numbers"

What is the quotient of $1 \frac{4}{5} \div \frac{1}{10}$?

You MUST reduce your answer to lowest terms.

If your answer is a mixed number, be sure to put a space between the whole number and the fraction in your answer. The answer should look like this: $6 \frac{2}{3}$. Not like this: $62/3$

60) Assistent #48470 "48470 - Dividing Fractions with Mixed Numbers"

What is the quotient of $2 \frac{1}{2} \div \frac{1}{11}$?

You MUST reduce your answer to lowest terms.

If your answer is a mixed number, be sure to put a space between the whole number and the fraction in your answer. The answer should look like this: $6 \frac{2}{3}$. Not like this: $62/3$

61) Assistent #48471 "48471 - Dividing Fractions with Mixed Numbers"

What is the quotient of $1 \frac{1}{2} \div \frac{1}{2}$?

You MUST reduce your answer to lowest terms.

If your answer is a mixed number, be sure to put a space between the whole number and the fraction in your answer. The answer should look like this: $6 \frac{2}{3}$. Not like this: $62/3$

62) Assistent #48472 "48472 - Dividing Fractions with Mixed Numbers"

What is the quotient of $1 \frac{1}{3} \div \frac{1}{3}$?

You MUST reduce your answer to lowest terms.

If your answer is a mixed number, be sure to put a space between the whole number and the fraction in your answer. The answer should look like this: $6 \frac{2}{3}$. Not like this: $62/3$

63) Assistent #48473 "48473 - Dividing Fractions with Mixed Numbers"

What is the quotient of $1 \frac{1}{4} \div \frac{1}{4}$?

You MUST reduce your answer to lowest terms.

If your answer is a mixed number, be sure to put a space between the whole number and the fraction in your answer. The answer should look like this: $6 \frac{2}{3}$. Not like this: $62/3$

64) Assistent #48474 "48474 - Dividing Fractions with Mixed Numbers"

What is the quotient of $1 \frac{1}{5} \div \frac{1}{5}$?

You MUST reduce your answer to lowest terms.

If your answer is a mixed number, be sure to put a space between the whole number and the fraction in your answer. The answer should look like this: $6 \frac{2}{3}$. Not like this: $62/3$

65) Assistent #48475 "48475 - Dividing Fractions with Mixed Numbers"

What is the quotient of $1 \frac{2}{3} \div \frac{1}{6}$?

You MUST reduce your answer to lowest terms.

If your answer is a mixed number, be sure to put a space between the whole number and the fraction in your answer. The answer should look like this: $6 \frac{2}{3}$. Not like this: $62/3$

66) Assistent #48476 "48476 - Dividing Fractions with Mixed Numbers"

What is the quotient of $1 \frac{2}{5} \div \frac{1}{7}$?

You MUST reduce your answer to lowest terms.

If your answer is a mixed number, be sure to put a space between the whole number and the fraction in your answer. The answer should look like this: $6 \frac{2}{3}$. Not like this: $62/3$

67) Assistent #48477 "48477 - Dividing Fractions with Mixed Numbers"

What is the quotient of $1 \frac{3}{4} \div \frac{1}{8}$?

You MUST reduce your answer to lowest terms.

If your answer is a mixed number, be sure to put a space between the whole number and the fraction in your answer. The answer should look like this: $6 \frac{2}{3}$. Not like this: $62/3$

68) Assistent #48478 "48478 - Dividing Fractions with Mixed Numbers"

What is the quotient of $1 \frac{3}{5} \div \frac{1}{9}$?

You MUST reduce your answer to lowest terms.

If your answer is a mixed number, be sure to put a space between the whole number and the fraction in your answer. The answer should look like this: 6 2/3. Not like this: 62/3

69) Assistent #48479 "48479 - Dividing Fractions with Mixed Numbers"

What is the quotient of $1 \frac{4}{5} \div \frac{1}{10}$?

You MUST reduce your answer to lowest terms.

If your answer is a mixed number, be sure to put a space between the whole number and the fraction in your answer. The answer should look like this: 6 2/3. Not like this: 62/3

70) Assistent #48480 "48480 - Dividing Fractions with Mixed Numbers"

What is the quotient of $2 \frac{1}{2} \div \frac{1}{11}$?

You MUST reduce your answer to lowest terms.

If your answer is a mixed number, be sure to put a space between the whole number and the fraction in your answer. The answer should look like this: 6 2/3. Not like this: 62/3

71) Assistent #48491 "48491 - 46275 - Dividing Fractions with Mixed Numbers"

What is the quotient of $1 \frac{1}{2} \div \frac{1}{2}$?

You MUST reduce your answer to lowest terms.

If your answer is a mixed number, be sure to put a space between the whole number and the fraction in your answer. The answer should look like this: 6 2/3. Not like this: 62/3

72) Assistent #48492 "48492 - 46275 - Dividing Fractions with Mixed Numbers"

What is the quotient of $1 \frac{1}{3} \div \frac{1}{3}$?

You MUST reduce your answer to lowest terms.

If your answer is a mixed number, be sure to put a space between the whole number and the fraction in your answer. The answer should look like this: 6 2/3. Not like this: 62/3

73) Assistent #48493 "48493 - 46275 - Dividing Fractions with Mixed Numbers"

What is the quotient of $1 \frac{1}{4} \div \frac{1}{4}$?

You MUST reduce your answer to lowest terms.

If your answer is a mixed number, be sure to put a space between the whole number and the fraction in your answer. The answer should look like this: $6 \frac{2}{3}$. Not like this: $62/3$

74) Assistent #48494 "48494 - 46275 - Dividing Fractions with Mixed Numbers"

What is the quotient of $1 \frac{1}{5} \div \frac{1}{5}$?

You MUST reduce your answer to lowest terms.

If your answer is a mixed number, be sure to put a space between the whole number and the fraction in your answer. The answer should look like this: $6 \frac{2}{3}$. Not like this: $62/3$

75) Assistent #48495 "48495 - 46275 - Dividing Fractions with Mixed Numbers"

What is the quotient of $1 \frac{2}{3} \div \frac{1}{6}$?

You MUST reduce your answer to lowest terms.

If your answer is a mixed number, be sure to put a space between the whole number and the fraction in your answer. The answer should look like this: $6 \frac{2}{3}$. Not like this: $62/3$

76) Assistent #48496 "48496 - 46275 - Dividing Fractions with Mixed Numbers"

What is the quotient of $1 \frac{2}{5} \div \frac{1}{7}$?

You MUST reduce your answer to lowest terms.

If your answer is a mixed number, be sure to put a space between the whole number and the fraction in your answer. The answer should look like this: $6 \frac{2}{3}$. Not like this: $62/3$

77) Assistent #48497 "48497 - 46275 - Dividing Fractions with Mixed Numbers"

What is the quotient of $1 \frac{3}{4} \div \frac{1}{8}$?

You MUST reduce your answer to lowest terms.

If your answer is a mixed number, be sure to put a space between the whole number and the fraction in your answer. The answer should look like this: $6 \frac{2}{3}$. Not like this: $62/3$

78) Assistent #48498 "48498 - 46275 - Dividing Fractions with Mixed Numbers"

What is the quotient of $1 \frac{3}{5} \div \frac{1}{9}$?

You MUST reduce your answer to lowest terms.

If your answer is a mixed number, be sure to put a space between the whole number and the fraction in your answer. The answer should look like this: $6 \frac{2}{3}$. Not like this: $62/3$

79) Assistent #48499 "48499 - 46275 - Dividing Fractions with Mixed Numbers"

What is the quotient of $1 \frac{4}{5} \div \frac{1}{10}$?

You MUST reduce your answer to lowest terms.

If your answer is a mixed number, be sure to put a space between the whole number and the fraction in your answer. The answer should look like this: $6 \frac{2}{3}$. Not like this: $62/3$

80) Assistent #48500 "48500 - 46275 - Dividing Fractions with Mixed Numbers"

What is the quotient of $2 \frac{1}{2} \div \frac{1}{11}$?

You MUST reduce your answer to lowest terms.

If your answer is a mixed number, be sure to put a space between the whole number and the fraction in your answer. The answer should look like this: $6 \frac{2}{3}$. Not like this: $62/3$

81) Assistent #48501 "48501 - 46275 - Dividing Fractions with Mixed Numbers"

What is the quotient of $1 \frac{1}{2} \div \frac{1}{2}$?

You MUST reduce your answer to lowest terms.

If your answer is a mixed number, be sure to put a space between the whole number and the fraction in your answer. The answer should look like this: $6 \frac{2}{3}$. Not like this: $62/3$

82) Assistent #48502 "48502 - 46275 - Dividing Fractions with Mixed Numbers"

What is the quotient of $1 \frac{1}{3} \div \frac{1}{3}$?

You MUST reduce your answer to lowest terms.

If your answer is a mixed number, be sure to put a space between the whole number and the fraction in your answer. The answer should look like this: $6 \frac{2}{3}$. Not like this: $62/3$

83) Assistent #48503 "48503 - 46275 - Dividing Fractions with Mixed Numbers"

What is the quotient of $1 \frac{1}{4} \div \frac{1}{4}$?

You MUST reduce your answer to lowest terms.

If your answer is a mixed number, be sure to put a space between the whole number and the fraction in your answer. The answer should look like this: $6 \frac{2}{3}$. Not like this: $62/3$

84) Assistent #48504 "48504 - 46275 - Dividing Fractions with Mixed Numbers"

What is the quotient of $1 \frac{1}{5} \div \frac{1}{5}$?

You MUST reduce your answer to lowest terms.

If your answer is a mixed number, be sure to put a space between the whole number and the fraction in your answer. The answer should look like this: $6 \frac{2}{3}$. Not like this: $62/3$

85) Assistent #48505 "48505 - 46275 - Dividing Fractions with Mixed Numbers"

What is the quotient of $1 \frac{2}{3} \div \frac{1}{6}$?

You MUST reduce your answer to lowest terms.

If your answer is a mixed number, be sure to put a space between the whole number and the fraction in your answer. The answer should look like this: $6 \frac{2}{3}$. Not like this: $62/3$

86) Assistent #48506 "48506 - 46275 - Dividing Fractions with Mixed Numbers"

What is the quotient of $1 \frac{2}{5} \div \frac{1}{7}$?

You MUST reduce your answer to lowest terms.

If your answer is a mixed number, be sure to put a space between the whole number and the fraction in your answer. The answer should look like this: $6 \frac{2}{3}$. Not like this: $62/3$

87) Assistent #48507 "48507 - 46275 - Dividing Fractions with Mixed Numbers"

What is the quotient of $1 \frac{3}{4} \div \frac{1}{8}$?

You MUST reduce your answer to lowest terms.

If your answer is a mixed number, be sure to put a space between the whole number and the fraction in your answer. The answer should look like this: 6 2/3. Not like this: 62/3

88) Assistent #48508 "48508 - 46275 - Dividing Fractions with Mixed Numbers"

What is the quotient of $1 \frac{3}{5} \div \frac{1}{9}$?

You MUST reduce your answer to lowest terms.

If your answer is a mixed number, be sure to put a space between the whole number and the fraction in your answer. The answer should look like this: 6 2/3. Not like this: 62/3

89) Assistent #48509 "48509 - 46275 - Dividing Fractions with Mixed Numbers"

What is the quotient of $1 \frac{4}{5} \div \frac{1}{10}$?

You MUST reduce your answer to lowest terms.

If your answer is a mixed number, be sure to put a space between the whole number and the fraction in your answer. The answer should look like this: 6 2/3. Not like this: 62/3

90) Assistent #48510 "48510 - 46275 - Dividing Fractions with Mixed Numbers"

What is the quotient of $2 \frac{1}{2} \div \frac{1}{11}$?

You MUST reduce your answer to lowest terms.

If your answer is a mixed number, be sure to put a space between the whole number and the fraction in your answer. The answer should look like this: 6 2/3. Not like this: 62/3

91) Assistent #48511 "48511 - 46275 - Dividing Fractions with Mixed Numbers"

What is the quotient of $1 \frac{1}{2} \div \frac{1}{2}$?

You MUST reduce your answer to lowest terms.

If your answer is a mixed number, be sure to put a space between the whole number and the fraction in your answer. The answer should look like this: 6 2/3. Not like this: 62/3

92) Assistent #48512 "48512 - 46275 - Dividing Fractions with Mixed Numbers"

What is the quotient of $1 \frac{1}{3} \div \frac{1}{3}$?

You MUST reduce your answer to lowest terms.

If your answer is a mixed number, be sure to put a space between the whole number and the fraction in your answer. The answer should look like this: $6 \frac{2}{3}$. Not like this: $62/3$

93) Assistent #48513 "48513 - 46275 - Dividing Fractions with Mixed Numbers"

What is the quotient of $1 \frac{1}{4} \div \frac{1}{4}$?

You MUST reduce your answer to lowest terms.

If your answer is a mixed number, be sure to put a space between the whole number and the fraction in your answer. The answer should look like this: $6 \frac{2}{3}$. Not like this: $62/3$

94) Assistent #48514 "48514 - 46275 - Dividing Fractions with Mixed Numbers"

What is the quotient of $1 \frac{1}{5} \div \frac{1}{5}$?

You MUST reduce your answer to lowest terms.

If your answer is a mixed number, be sure to put a space between the whole number and the fraction in your answer. The answer should look like this: $6 \frac{2}{3}$. Not like this: $62/3$

95) Assistent #48515 "48515 - 46275 - Dividing Fractions with Mixed Numbers"

What is the quotient of $1 \frac{2}{3} \div \frac{1}{6}$?

You MUST reduce your answer to lowest terms.

If your answer is a mixed number, be sure to put a space between the whole number and the fraction in your answer. The answer should look like this: $6 \frac{2}{3}$. Not like this: $62/3$

96) Assistent #48516 "48516 - 46275 - Dividing Fractions with Mixed Numbers"

What is the quotient of $1 \frac{2}{5} \div \frac{1}{7}$?

You MUST reduce your answer to lowest terms.

If your answer is a mixed number, be sure to put a space between the whole number and the fraction in your answer. The answer should look like this: $6 \frac{2}{3}$. Not like this: $62/3$

97) Assistent #48517 "48517 - 46275 - Dividing Fractions with Mixed Numbers"

What is the quotient of $1 \frac{3}{4} \div \frac{1}{8}$?

You MUST reduce your answer to lowest terms.

If your answer is a mixed number, be sure to put a space between the whole number and the fraction in your answer. The answer should look like this: $6 \frac{2}{3}$. Not like this: $62/3$

98) Assistent #48518 "48518 - 46275 - Dividing Fractions with Mixed Numbers"

What is the quotient of $1 \frac{3}{5} \div \frac{1}{9}$?

You MUST reduce your answer to lowest terms.

If your answer is a mixed number, be sure to put a space between the whole number and the fraction in your answer. The answer should look like this: $6 \frac{2}{3}$. Not like this: $62/3$

99) Assistent #48519 "48519 - 46275 - Dividing Fractions with Mixed Numbers"

What is the quotient of $1 \frac{4}{5} \div \frac{1}{10}$?

You MUST reduce your answer to lowest terms.

If your answer is a mixed number, be sure to put a space between the whole number and the fraction in your answer. The answer should look like this: $6 \frac{2}{3}$. Not like this: $62/3$

100) Assistent #48520 "48520 - 46275 - Dividing Fractions with Mixed Numbers"

What is the quotient of $2 \frac{1}{2} \div \frac{1}{11}$?

You MUST reduce your answer to lowest terms.

If your answer is a mixed number, be sure to put a space between the whole number and the fraction in your answer. The answer should look like this: $6 \frac{2}{3}$. Not like this: $62/3$

Problem Set 6921 "Greatest Common Factor - THE SKILL BUILDING SET" id:[6921]

1) Assistent #48742 "48742 - Greatest Common Factor"

Find the greatest common factor for 45 and 30.

2) Assistent #48743 "48743 - Greatest Common Factor"

Find the greatest common factor for 24 and 16.

3) Assistent #48744 "48744 - Greatest Common Factor"

Find the greatest common factor for 30 and 20.

4) Assistent #48745 "48745 - Greatest Common Factor"

Find the greatest common factor for 60 and 40.

5) Assistent #48746 "48746 - Greatest Common Factor"

Find the greatest common factor for 45 and 30.

6) Assistent #48747 "48747 - Greatest Common Factor"

Find the greatest common factor for 24 and 16.

7) Assistent #48748 "48748 - Greatest Common Factor"

Find the greatest common factor for 48 and 32.

8) Assistent #48749 "48749 - Greatest Common Factor"

Find the greatest common factor for 36 and 24.

9) Assistent #48750 "48750 - Greatest Common Factor"

Find the greatest common factor for 42 and 28.

10) Assisment #48751 "48751 - Greatest Common Factor"

Find the greatest common factor for 72 and 48.

11) Assisment #48752 "48752 - Greatest Common Factor"

Find the greatest common factor for 72 and 48.

12) Assisment #48753 "48753 - Greatest Common Factor"

Find the greatest common factor for 24 and 16.

13) Assisment #48754 "48754 - Greatest Common Factor"

Find the greatest common factor for 36 and 24.

14) Assisment #48755 "48755 - Greatest Common Factor"

Find the greatest common factor for 24 and 16.

15) Assisment #48756 "48756 - Greatest Common Factor"

Find the greatest common factor for 63 and 42.

16) Assisment #48757 "48757 - Greatest Common Factor"

Find the greatest common factor for 30 and 20.

17) Assisment #48758 "48758 - Greatest Common Factor"

Find the greatest common factor for 30 and 20.

18) Assisment #48759 "48759 - Greatest Common Factor"

Find the greatest common factor for 36 and 24.

19) Assisment #48760 "48760 - Greatest Common Factor"

Find the greatest common factor for 36 and 24.

20) Assisment #48761 "48761 - Greatest Common Factor"

Find the greatest common factor for 63 and 42.

21) Assisment #48762 "48762 - Greatest Common Factor"

Find the greatest common factor for 84 and 56.

22) Assisment #48763 "48763 - Greatest Common Factor"

Find the greatest common factor for 48 and 32.

23) Assisment #48764 "48764 - Greatest Common Factor"

Find the greatest common factor for 84 and 56.

24) Assisment #48765 "48765 - Greatest Common Factor"

Find the greatest common factor for 45 and 30.

25) Assisment #48766 "48766 - Greatest Common Factor"

Find the greatest common factor for 96 and 64.

26) Assisment #48767 "48767 - Greatest Common Factor"

Find the greatest common factor for 72 and 48.

27) Assisment #48768 "48768 - Greatest Common Factor"

Find the greatest common factor for 30 and 20.

28) Assisment #48769 "48769 - Greatest Common Factor"

Find the greatest common factor for 63 and 42.

29) Assisment #48770 "48770 - Greatest Common Factor"

Find the greatest common factor for 54 and 36.

30) Assisment #48771 "48771 - Greatest Common Factor"

Find the greatest common factor for 72 and 48.

31) Assisment #48772 "48772 - Greatest Common Factor"

Find the greatest common factor for 84 and 56.

32) Assisment #48773 "48773 - Greatest Common Factor"

Find the greatest common factor for 63 and 42.

33) Assisment #48775 "48775 - Greatest Common Factor"

Find the greatest common factor for 63 and 42.

34) Assisment #48776 "48776 - Greatest Common Factor"

Find the greatest common factor for 24 and 16.

35) Assisment #48778 "48778 - Greatest Common Factor"

Find the greatest common factor for 84 and 56.

36) Assisment #48779 "48779 - Greatest Common Factor"

Find the greatest common factor for 72 and 48.

37) Assisment #48780 "48780 - Greatest Common Factor"

Find the greatest common factor for 45 and 30.

38) Assisment #48781 "48781 - Greatest Common Factor"

Find the greatest common factor for 48 and 32.

39) Assisment #48782 "48782 - Greatest Common Factor"

Find the greatest common factor for 36 and 24.

40) Assisment #48783 "48783 - Greatest Common Factor"

Find the greatest common factor for 24 and 16.

41) Assisment #48784 "48784 - Greatest Common Factor"

Find the greatest common factor for 48 and 32.

42) Assisment #48785 "48785 - Greatest Common Factor"

Find the greatest common factor for 48 and 32.

43) Assisment #48786 "48786 - Greatest Common Factor"

Find the greatest common factor for 45 and 30.

44) Assisment #48787 "48787 - Greatest Common Factor"

Find the greatest common factor for 36 and 24.

45) Assisment #48788 "48788 - Greatest Common Factor"

Find the greatest common factor for 42 and 28.

46) Assisment #48789 "48789 - Greatest Common Factor"

Find the greatest common factor for 84 and 56.

47) Assisment #48790 "48790 - Greatest Common Factor"

Find the greatest common factor for 72 and 48.

48) Assisment #48791 "48791 - Greatest Common Factor"

Find the greatest common factor for 60 and 40.

49) Assisment #48832 "48832 - Greatest Common Factor"

Find the greatest common factor for 63 and 42.

50) Assisment #48833 "48833 - Greatest Common Factor"

Find the greatest common factor for 72 and 48.

51) Assisment #48834 "48834 - Greatest Common Factor"

Find the greatest common factor for 48 and 32.

52) Assisment #48835 "48835 - Greatest Common Factor"

Find the greatest common factor for 30 and 20.

53) Assisment #48836 "48836 - Greatest Common Factor"

Find the greatest common factor for 63 and 42.

54) Assisment #48837 "48837 - Greatest Common Factor"

Find the greatest common factor for 84 and 56.

55) Assisment #48838 "48838 - Greatest Common Factor"

Find the greatest common factor for 42 and 28.

56) Assisment #48839 "48839 - Greatest Common Factor"

Find the greatest common factor for 54 and 36.

57) Assisment #48840 "48840 - Greatest Common Factor"

Find the greatest common factor for 54 and 36.

58) Assisment #48841 "48841 - Greatest Common Factor"

Find the greatest common factor for 60 and 40.

59) Assisment #48852 "48852 - Greatest Common Factor"

Find the greatest common factor for 60 and 40.

60) Assisment #48853 "48853 - Greatest Common Factor"

Find the greatest common factor for 96 and 64.

61) Assisment #48854 "48854 - Greatest Common Factor"

Find the greatest common factor for 72 and 48.

62) Assisment #48855 "48855 - Greatest Common Factor"

Find the greatest common factor for 72 and 48.

63) Assisment #48856 "48856 - Greatest Common Factor"

Find the greatest common factor for 36 and 24.

64) Assisment #48857 "48857 - Greatest Common Factor"

Find the greatest common factor for 54 and 36.

65) Assisment #48858 "48858 - Greatest Common Factor"

Find the greatest common factor for 30 and 20.

66) Assisment #48859 "48859 - Greatest Common Factor"

Find the greatest common factor for 48 and 32.

67) Assisment #48860 "48860 - Greatest Common Factor"

Find the greatest common factor for 42 and 28.

68) Assisment #48861 "48861 - Greatest Common Factor"

Find the greatest common factor for 72 and 48.

69) Assisment #48864 "48864 - Greatest Common Factor"

Find the greatest common factor for 54 and 36.

70) Assisment #48866 "48866 - Greatest Common Factor"

Find the greatest common factor for 84 and 56.

71) Assisment #48868 "48868 - Greatest Common Factor"

Find the greatest common factor for 63 and 42.

72) Assisment #48870 "48870 - Greatest Common Factor"

Find the greatest common factor for 54 and 36.

73) Assisment #48872 "48872 - Greatest Common Factor"

Find the greatest common factor for 36 and 24.

74) Assisment #48874 "48874 - Greatest Common Factor"

Find the greatest common factor for 84 and 56.

75) Assisment #48877 "48877 - Greatest Common Factor"

Find the greatest common factor for 96 and 64.

76) Assisment #48879 "48879 - Greatest Common Factor"

Find the greatest common factor for 36 and 24.

77) Assisment #48880 "48880 - Greatest Common Factor"

Find the greatest common factor for 36 and 24.

78) Assisment #48881 "48881 - Greatest Common Factor"

Find the greatest common factor for 60 and 40.

79) Assisment #48882 "48882 - Greatest Common Factor"

Find the greatest common factor for 45 and 30.

80) Assisment #48883 "48883 - Greatest Common Factor"

Find the greatest common factor for 30 and 20.

81) Assisment #48884 "48884 - Greatest Common Factor"

Find the greatest common factor for 63 and 42.

82) Assisment #48885 "48885 - Greatest Common Factor"

Find the greatest common factor for 36 and 24.

83) Assisment #48886 "48886 - Greatest Common Factor"

Find the greatest common factor for 24 and 16.

84) Assistent #48887 "48887 - Greatest Common Factor"

Find the greatest common factor for 36 and 24.

85) Assistent #48888 "48888 - Greatest Common Factor"

Find the greatest common factor for 42 and 28.

86) Assistent #48889 "48889 - Greatest Common Factor"

Find the greatest common factor for 72 and 48.

87) Assistent #48890 "48890 - Greatest Common Factor"

Find the greatest common factor for 24 and 16.

88) Assistent #48891 "48891 - Greatest Common Factor"

Find the greatest common factor for 36 and 24.

89) Assistent #48902 "48902 - Greatest Common Factor"

Find the greatest common factor for 48 and 32.

90) Assistent #48903 "48903 - Greatest Common Factor"

Find the greatest common factor for 54 and 36.

91) Assistent #48904 "48904 - Greatest Common Factor"

Find the greatest common factor for 60 and 40.

92) Assistent #48905 "48905 - Greatest Common Factor"

Find the greatest common factor for 63 and 42.

93) Assistent #48906 "48906 - Greatest Common Factor"

Find the greatest common factor for 54 and 36.

94) Assisment #48907 "48907 - Greatest Common Factor"

Find the greatest common factor for 45 and 30.

95) Assisment #48908 "48908 - Greatest Common Factor"

Find the greatest common factor for 36 and 24.

96) Assisment #48909 "48909 - Greatest Common Factor"

Find the greatest common factor for 63 and 42.

97) Assisment #48910 "48910 - Greatest Common Factor"

Find the greatest common factor for 45 and 30.

98) Assisment #48911 "48911 - Greatest Common Factor"

Find the greatest common factor for 72 and 48.

99) Assisment #48912 "48912 - Greatest Common Factor"

Find the greatest common factor for 36 and 24.

100) Assisment #48913 "48913 - Greatest Common Factor"

Find the greatest common factor for 60 and 40.

101) Assisment #48914 "48914 - Greatest Common Factor"

Find the greatest common factor for 60 and 40.

102) Assisment #48915 "48915 - Greatest Common Factor"

Find the greatest common factor for 72 and 48.

103) Assisment #48916 "48916 - Greatest Common Factor"

Find the greatest common factor for 72 and 48.

104) Assisment #48917 "48917 - Greatest Common Factor"

Find the greatest common factor for 63 and 42.

105) Assistent #48918 "48918 - Greatest Common Factor"

Find the greatest common factor for 72 and 48.

106) Assistent #48919 "48919 - Greatest Common Factor"

Find the greatest common factor for 72 and 48.

107) Assistent #48920 "48920 - Greatest Common Factor"

Find the greatest common factor for 60 and 40.

108) Assistent #48921 "48921 - Greatest Common Factor"

Find the greatest common factor for 45 and 30.

Problem Set 6854 "Absolute Value" id:[6854]

1) Assistent #46521 "46521 - 27415 - Absolute Value - Easy Simplifications"

Simplify the following:

$$|-29|$$

2) Assistent #46522 "46522 - 27415 - Absolute Value - Easy Simplifications"

Simplify the following:

$$|-2|$$

3) Assistent #46523 "46523 - 27415 - Absolute Value - Easy Simplifications"

Simplify the following:

$$|-18|$$

4) Assistent #46524 "46524 - 27415 - Absolute Value - Easy Simplifications"

Simplify the following:

$$| -19 |$$

5) Assistent #46525 "46525 - 27415 - Absolute Value - Easy Simplifications"

Simplify the following:

$$| -15 |$$

6) Assistent #46526 "46526 - 27415 - Absolute Value - Easy Simplifications"

Simplify the following:

$$| -15 |$$

7) Assistent #46527 "46527 - 27415 - Absolute Value - Easy Simplifications"

Simplify the following:

$$| -30 |$$

8) Assistent #46528 "46528 - 27415 - Absolute Value - Easy Simplifications"

Simplify the following:

$$| -21 |$$

9) Assistent #46529 "46529 - 27415 - Absolute Value - Easy Simplifications"

Simplify the following:

$$|-30|$$

10) Assistent #46530 "46530 - 27415 - Absolute Value - Easy Simplifications"

Simplify the following:

$$|-2|$$

11) Assistent #46936 "46936 - 27415 - Absolute Value - Easy Simplifications"

Simplify the following:

$$|-12|$$

12) Assistent #46937 "46937 - 27415 - Absolute Value - Easy Simplifications"

Simplify the following:

$$|-23|$$

13) Assistent #46938 "46938 - 27415 - Absolute Value - Easy Simplifications"

Simplify the following:

$$|-24|$$

14) Assistent #46939 "46939 - 27415 - Absolute Value - Easy Simplifications"

Simplify the following:

$$|-28|$$

15) Assistent #46940 "46940 - 27415 - Absolute Value - Easy Simplifications"

Simplify the following:

$$|-26|$$

16) Assistent #46941 "46941 - 27415 - Absolute Value - Easy Simplifications"

Simplify the following:

$$|-6|$$

17) Assisment #46942 "46942 - 27415 - Absolute Value - Easy Simplifications"

Simplify the following:

$$|-27|$$

18) Assisment #46943 "46943 - 27415 - Absolute Value - Easy Simplifications"

Simplify the following:

$$|-5|$$

19) Assisment #46944 "46944 - 27415 - Absolute Value - Easy Simplifications"

Simplify the following:

$$|-2|$$

20) Assisment #46945 "46945 - 27415 - Absolute Value - Easy Simplifications"

Simplify the following:

$$|-29|$$

21) Assistent #46966 "46966 - 27415 - Absolute Value - Easy Simplifications"

Simplify the following:

$$| -3 |$$

22) Assistent #46967 "46967 - 27415 - Absolute Value - Easy Simplifications"

Simplify the following:

$$| -27 |$$

23) Assistent #46968 "46968 - 27415 - Absolute Value - Easy Simplifications"

Simplify the following:

$$| -25 |$$

24) Assistent #46969 "46969 - 27415 - Absolute Value - Easy Simplifications"

Simplify the following:

$$| -9 |$$

25) Assistent #46970 "46970 - 27415 - Absolute Value - Easy Simplifications"

Simplify the following:

$$|-15|$$

26) Assistent #46971 "46971 - 27415 - Absolute Value - Easy Simplifications"

Simplify the following:

$$|-22|$$

27) Assistent #46972 "46972 - 27415 - Absolute Value - Easy Simplifications"

Simplify the following:

$$|-7|$$

28) Assistent #46973 "46973 - 27415 - Absolute Value - Easy Simplifications"

Simplify the following:

$$|-8|$$

29) Assistent #46974 "46974 - 27415 - Absolute Value - Easy Simplifications"

Simplify the following:

$$|-2|$$

30) Assistent #46975 "46975 - 27415 - Absolute Value - Easy Simplifications"

Simplify the following:

$$| -29 |$$

31) Assistent #46539 "46539 - 27418 - Absolute Value - Hard Simplification"

Simplify the following:

$$| 28 - 30 |$$

32) Assistent #46542 "46542 - 27418 - Absolute Value - Hard Simplification"

Simplify the following:

$$| 1 - 35 |$$

33) Assistent #46543 "46543 - 27418 - Absolute Value - Hard Simplification"

Simplify the following:

$$| 28 - 33 |$$

34) Assistent #46544 "46544 - 27418 - Absolute Value - Hard Simplification"

Simplify the following:

$$| 8 - 30 |$$

35) Assistent #46545 "46545 - 27418 - Absolute Value - Hard Simplification"

Simplify the following:

$$| 11 - 34 |$$

36) Assistent #46546 "46546 - 27418 - Absolute Value - Hard Simplification"

Simplify the following:

$$| 3 - 38 |$$

37) Assistent #46547 "46547 - 27418 - Absolute Value - Hard Simplification"

Simplify the following:

$$| 2 - 37 |$$

38) Assistent #46548 "46548 - 27418 - Absolute Value - Hard Simplification"

Simplify the following:

$$| 4 - 31 |$$

39) Assistent #46549 "46549 - 27418 - Absolute Value - Hard Simplification"

Simplify the following:

$$| 22 - 35 |$$

40) Assistent #46550 "46550 - 27418 - Absolute Value - Hard Simplification"

Simplify the following:

$$| 14 - 34 |$$

41) Assistent #46946 "46946 - 27418 - Absolute Value - Hard Simplification"

Simplify the following:

$$| 19 - 30 |$$

42) Assistent #46947 "46947 - 27418 - Absolute Value - Hard Simplification"

Simplify the following:

$$| 26 - 33 |$$

43) Assistent #46948 "46948 - 27418 - Absolute Value - Hard Simplification"

Simplify the following:

$$| 29 - 38 |$$

44) Assistent #46949 "46949 - 27418 - Absolute Value - Hard Simplification"

Simplify the following:

$$| 5 - 31 |$$

45) Assistent #46950 "46950 - 27418 - Absolute Value - Hard Simplification"

Simplify the following:

$$| 16 - 32 |$$

46) Assistent #46951 "46951 - 27418 - Absolute Value - Hard Simplification"

Simplify the following:

$$| 6 - 38 |$$

47) Assistent #46952 "46952 - 27418 - Absolute Value - Hard Simplification"

Simplify the following:

$$| 20 - 37 |$$

48) Assistent #46953 "46953 - 27418 - Absolute Value - Hard Simplification"

Simplify the following:

$$| 3 - 30 |$$

49) Assistent #46954 "46954 - 27418 - Absolute Value - Hard Simplification"

Simplify the following:

$$| 3 - 36 |$$

50) Assistent #46955 "46955 - 27418 - Absolute Value - Hard Simplification"

Simplify the following:

$$| 24 - 32 |$$

51) Assistent #46956 "46956 - 27418 - Absolute Value - Hard Simplification"

Simplify the following:

$$| 17 - 32 |$$

52) Assistent #46957 "46957 - 27418 - Absolute Value - Hard Simplification"

Simplify the following:

$$| 14 - 38 |$$

53) Assistent #46958 "46958 - 27418 - Absolute Value - Hard Simplification"

Simplify the following:

$$| 7 - 36 |$$

54) Assistent #46959 "46959 - 27418 - Absolute Value - Hard Simplification"

Simplify the following:

$$| 2 - 30 |$$

55) Assistent #46960 "46960 - 27418 - Absolute Value - Hard Simplification"

Simplify the following:

$$|12 - 31|$$

56) Assistent #46961 "46961 - 27418 - Absolute Value - Hard Simplification"

Simplify the following:

$$|4 - 35|$$

57) Assistent #46962 "46962 - 27418 - Absolute Value - Hard Simplification"

Simplify the following:

$$|7 - 33|$$

58) Assistent #46963 "46963 - 27418 - Absolute Value - Hard Simplification"

Simplify the following:

$$|24 - 32|$$

59) Assistent #46964 "46964 - 27418 - Absolute Value - Hard Simplification"

Simplify the following:

$$|2 - 31|$$

60) Assistent #46965 "46965 - 27418 - Absolute Value - Hard Simplification"

Simplify the following:

$$|1 - 35|$$

61) Assistent #46561 "46561 - Absolute Value - Addition"

What is the value of the expression below?

$$|3| + |-6|$$

62) Assistent #46562 "46562 - Absolute Value - Addition"

What is the value of the expression below?

$$|4| + |-13|$$

63) Assistent #46563 "46563 - Absolute Value - Addition"

What is the value of the expression below?

$$|17| + |-6|$$

64) Assistent #46564 "46564 - Absolute Value - Addition"

What is the value of the expression below?

$$|7| + |-12|$$

65) Assistent #46565 "46565 - Absolute Value - Addition"

What is the value of the expression below?

$$|15| + |-6|$$

66) Assistent #46566 "46566 - Absolute Value - Addition"

What is the value of the expression below?

$$|20| + |-9|$$

67) Assistent #46567 "46567 - Absolute Value - Addition"

What is the value of the expression below?

$$|15| + |-1|$$

69) Assistent #46569 "46569 - Absolute Value - Addition"

What is the value of the expression below?

$$|16| + |-2|$$

70) Assistent #46570 "46570 - Absolute Value - Addition"

What is the value of the expression below?

$$|1| + |-12|$$

71) Assistent #46986 "46986 - Absolute Value - Addition"

What is the value of the expression below?

$$|14| + |-9|$$

72) Assistent #46987 "46987 - Absolute Value - Addition"

What is the value of the expression below?

$$|8| + |-7|$$

73) Assistent #46988 "46988 - Absolute Value - Addition"

What is the value of the expression below?

$$|14| + |-4|$$

74) Assistent #46989 "46989 - Absolute Value - Addition"

What is the value of the expression below?

$$|7| + |-20|$$

76) Assistent #46991 "46991 - Absolute Value - Addition"

What is the value of the expression below?

$$|7| + |-1|$$

77) Assistent #46992 "46992 - Absolute Value - Addition"

What is the value of the expression below?

$$|6| + |-2|$$

78) Assistent #46993 "46993 - Absolute Value - Addition"

What is the value of the expression below?

$$|16| + |-3|$$

79) Assistent #46994 "46994 - Absolute Value - Addition"

What is the value of the expression below?

$$|5| + |-20|$$

80) Assistent #46995 "46995 - Absolute Value - Addition"

What is the value of the expression below?

$$|19| + |-3|$$

81) Assistent #46997 "46997 - Absolute Value - Addition"

What is the value of the expression below?

$$|2| + |-10|$$

83) Assistent #46999 "46999 - Absolute Value - Addition"

What is the value of the expression below?

$$|20| + |-5|$$

84) Assistent #47000 "47000 - Absolute Value - Addition"

What is the value of the expression below?

$$|16| + |-1|$$

85) Assistent #47001 "47001 - Absolute Value - Addition"

What is the value of the expression below?

$$|11| + |-14|$$

86) Assistent #47002 "47002 - Absolute Value - Addition"

What is the value of the expression below?

$$|9| + |-17|$$

87) Assistent #47003 "47003 - Absolute Value - Addition"

What is the value of the expression below?

$$|19| + |-10|$$

88) Assistent #47004 "47004 - Absolute Value - Addition"

What is the value of the expression below?

$$|3| + |-19|$$

89) Assistent #47005 "47005 - Absolute Value - Addition"

What is the value of the expression below?

$$|19| + |-17|$$

90) Assisment #47006 "47006 - Absolute Value - Addition"

What is the value of the expression below?

$$|6| + |-4|$$

91) Assisment #47008 "47008 - 27970 - 7th Grade: Accentuate the Negative - Morph 2006 grade 7 #12"

What is the value of the expression below?

$$|-4| - |-12|$$

92) Assisment #47009 "47009 - 27970 - 7th Grade: Accentuate the Negative - Morph 2006 grade 7 #12"

What is the value of the expression below?

$$|-19| - |-16|$$

93) Assisment #47010 "47010 - 27970 - 7th Grade: Accentuate the Negative - Morph 2006 grade 7 #12"

What is the value of the expression below?

$$|-17| - |-12|$$

94) Assisment #47011 "47011 - 27970 - 7th Grade: Accentuate the Negative - Morph 2006 grade 7 #12"

What is the value of the expression below?

$$|-11| - |-7|$$

95) Assisment #47012 "47012 - 27970 - 7th Grade: Accentuate the Negative - Morph 2006 grade 7 #12"

What is the value of the expression below?

$$|-15| - |-11|$$

96) Assisment #47013 "47013 - 27970 - 7th Grade: Accentuate the Negative - Morph 2006 grade 7 #12"

What is the value of the expression below?

$$|-7| - |-13|$$

97) Assisment #47014 "47014 - 27970 - 7th Grade: Accentuate the Negative - Morph 2006 grade 7 #12"

What is the value of the expression below?

$$|-17| - |-2|$$

98) Assisment #47015 "47015 - 27970 - 7th Grade: Accentuate the Negative - Morph 2006 grade 7 #12"

What is the value of the expression below?

$$|-6| - |-3|$$

99) Assisment #47016 "47016 - 27970 - 7th Grade: Accentuate the Negative - Morph 2006 grade 7 #12"

What is the value of the expression below?

$$|-5| - |-15|$$

100) Assisment #47017 "47017 - 27970 - 7th Grade: Accentuate the Negative - Morph 2006 grade 7 #12"

What is the value of the expression below?

$$|-19| - |-1|$$

101) Assisment #47018 "47018 - 27970 - 7th Grade: Accentuate the Negative - Morph 2006 grade 7 #12"

What is the value of the expression below?

$$|-11| - |-14|$$

102) Assisment #47019 "47019 - 27970 - 7th Grade: Accentuate the Negative - Morph 2006 grade 7 #12"

What is the value of the expression below?

$$|-17| - |-3|$$

103) Assistent #47020 "47020 - 27970 - 7th Grade: Accentuate the Negative - Morph 2006 grade 7 #12"

What is the value of the expression below?

$$|-14| - |-17|$$

104) Assistent #47021 "47021 - 27970 - 7th Grade: Accentuate the Negative - Morph 2006 grade 7 #12"

What is the value of the expression below?

$$|-11| - |-15|$$

105) Assistent #47022 "47022 - 27970 - 7th Grade: Accentuate the Negative - Morph 2006 grade 7 #12"

What is the value of the expression below?

$$|-10| - |-15|$$

106) Assistent #47023 "47023 - 27970 - 7th Grade: Accentuate the Negative - Morph 2006 grade 7 #12"

What is the value of the expression below?

$$|-7| - |-16|$$

107) Assistent #47024 "47024 - 27970 - 7th Grade: Accentuate the Negative - Morph 2006 grade 7 #12"

What is the value of the expression below?

$$|-15| - |-2|$$

108) Assistent #47025 "47025 - 27970 - 7th Grade: Accentuate the Negative - Morph 2006 grade 7 #12"

What is the value of the expression below?

$$|-12| - |-3|$$

109) Assistentment #47026 "47026 - 27970 - 7th Grade: Accentuate the Negative - Morph 2006 grade 7 #12"

What is the value of the expression below?

$$|-4| - |-16|$$

110) Assistentment #47027 "47027 - 27970 - 7th Grade: Accentuate the Negative - Morph 2006 grade 7 #12"

What is the value of the expression below?

$$|-4| - |-14|$$

Problem Set 5959 "Absolute Value, Addition, Subtraction" id:[5959]

1) Assistent #34288 "34288 - Morph 2006 #12"

What is the value of the expression below?

$$|7| + |-18|$$

2) Assistent #34289 "34289 - Morph 2006 #12"

What is the value of the expression below?

$$|19| + |-2|$$

3) Assistent #34290 "34290 - Morph 2006 #12"

What is the value of the expression below?

$$|16| + |-6|$$

4) Assistent #34291 "34291 - Morph 2006 #12"

What is the value of the expression below?

$$|5| + |-2|$$

5) Assistent #34292 "34292 - Morph 2006 #12"

What is the value of the expression below?

$$|8| + |-19|$$

6) Assistent #34293 "34293 - Morph 2006 #12"

What is the value of the expression below?

$$|14| + |-2|$$

7) Assistent #34294 "34294 - Morph 2006 #12"

What is the value of the expression below?

$$|18| + |-19|$$

8) Assistent #34295 "34295 - Morph 2006 #12"

What is the value of the expression below?

$$|9| + |-6|$$

9) Assistent #34296 "34296 - Morph 2006 #12"

What is the value of the expression below?

$$|20| + |-1|$$

10) Assistent #34297 "34297 - Morph 2006 #12"

What is the value of the expression below?

$$|7| + |-8|$$

11) Assistent #34298 "34298 - Morph 2006 #12"

What is the value of the expression below?

$$|10| + |-19|$$

12) Assistent #34299 "34299 - Morph 2006 #12"

What is the value of the expression below?

$$|4| + |-8|$$

13) Assistent #34300 "34300 - Morph 2006 #12"

What is the value of the expression below?

$$|8| + |-17|$$

14) Assistent #34301 "34301 - Morph 2006 #12"

What is the value of the expression below?

$$|8| + |-20|$$

15) Assistent #34302 "34302 - Morph 2006 #12"

What is the value of the expression below?

$$|13| + |-13|$$

16) Assistent #34303 "34303 - Morph 2006 #12"

What is the value of the expression below?

$$|14| + |-20|$$

17) Assistent #34304 "34304 - Morph 2006 #12"

What is the value of the expression below?

$$|18| + |-17|$$

18) Assistent #34305 "34305 - Morph 2006 #12"

What is the value of the expression below?

$$|18| + |-19|$$

19) Assistent #34306 "34306 - Morph 2006 #12"

What is the value of the expression below?

$$|18| + |-2|$$

20) Assistent #34307 "34307 - Morph 2006 #12"

21) Assistent #34308 "34308 - Morph 2006 #12"

What is the value of the expression below?

$$|7| + |-9|$$

22) Assistent #34309 "34309 - Morph 2006 #12"

What is the value of the expression below?

$$|16| + |-12|$$

23) Assistent #34310 "34310 - Morph 2006 #12"

What is the value of the expression below?

$$|7| + |-16|$$

24) Assistent #34311 "34311 - Morph 2006 #12"

What is the value of the expression below?

$$|2| + |-2|$$

25) Assistent #34312 "34312 - Morph 2006 #12"

What is the value of the expression below?

$$|6| + |-8|$$

26) Assistent #34313 "34313 - Morph 2006 #12"

What is the value of the expression below?

$$|9| + |-11|$$

28) Assistent #34315 "34315 - Morph 2006 #12"

What is the value of the expression below?

$$|10| + |-1|$$

29) Assistent #34316 "34316 - Morph 2006 #12"

What is the value of the expression below?

$$|13| + |-8|$$

30) Assistent #34317 "34317 - Morph 2006 #12"

What is the value of the expression below?

$$|18| + |-14|$$

31) Assistent #34318 "34318 - Morph 2006 #12"

What is the value of the expression below?

$$|-7| - |-17|$$

32) Assistent #34319 "34319 - Morph 2006 #12"

What is the value of the expression below?

$$|-8| - |-7|$$

33) Assistent #34320 "34320 - Morph 2006 #12"

What is the value of the expression below?

$$|-15| - |-17|$$

35) Assistent #34322 "34322 - Morph 2006 #12"

What is the value of the expression below?

$$|-7| - |-18|$$

36) Assistent #34323 "34323 - Morph 2006 #12"

What is the value of the expression below?

$$|-12| - |-7|$$

37) Assistent #34324 "34324 - Morph 2006 #12"

What is the value of the expression below?

$$|-7| - |-1|$$

38) Assistent #34325 "34325 - Morph 2006 #12"

What is the value of the expression below?

$$|-1| - |-3|$$

39) Assistent #34326 "34326 - Morph 2006 #12"

What is the value of the expression below?

$$|-15| - |-13|$$

40) Assistent #34327 "34327 - Morph 2006 #12"

What is the value of the expression below?

$$|-20| - |-9|$$

42) Assistent #34329 "34329 - Morph 2006 #12"

What is the value of the expression below?

$$|-14| - |-14|$$

43) Assistent #34330 "34330 - Morph 2006 #12"

What is the value of the expression below?

$$|-7| - |-18|$$

44) Assistent #34331 "34331 - Morph 2006 #12"

What is the value of the expression below?

$$|-4| - |-19|$$

45) Assistent #34332 "34332 - Morph 2006 #12"

What is the value of the expression below?

$$|-16| - |-16|$$

46) Assistent #34333 "34333 - Morph 2006 #12"

What is the value of the expression below?

$$|-19| - |-13|$$

47) Assistent #34334 "34334 - Morph 2006 #12"

What is the value of the expression below?

$$|-2| - |-11|$$

49) Assistent #34336 "34336 - Morph 2006 #12"

What is the value of the expression below?

$$|-16| - |-7|$$

50) Assistent #34337 "34337 - Morph 2006 #12"

What is the value of the expression below?

$$|-6| - |-11|$$

51) Assistent #34338 "34338 - Morph 2006 #12"

What is the value of the expression below?

$$|-18| - |-6|$$

52) Assistent #34339 "34339 - Morph 2006 #12"

What is the value of the expression below?

$$|-10| - |-5|$$

53) Assistent #34340 "34340 - Morph 2006 #12"

What is the value of the expression below?

$$|-2| - |-7|$$

54) Assistent #34341 "34341 - Morph 2006 #12"

What is the value of the expression below?

$$|-18| - |-8|$$

55) Assistent #34342 "34342 - Morph 2006 #12"

56) Assistent #34343 "34343 - Morph 2006 #12"

What is the value of the expression below?

$$|-11| - |-8|$$

57) Assistent #34344 "34344 - Morph 2006 #12"

What is the value of the expression below?

$$|-7| - |-9|$$

58) Assistent #34345 "34345 - Morph 2006 #12"

What is the value of the expression below?

$$|-16| - |-9|$$

59) Assistent #34346 "34346 - Morph 2006 #12"

What is the value of the expression below?

$$|-8| - |-17|$$

60) Assistent #34347 "34347 - Morph 2006 #12"

What is the value of the expression below?

$$|-4| - |-7|$$

Problem Set 6057 "Percent of" id:[6057]

1) Assisment #40699 "40699 - Percent of"

What is 140% of 90?

2) Assisment #40700 "40700 - Percent of"

What is 110% of 80?

3) Assisment #40701 "40701 - Percent of"

What is 140% of 50?

4) Assisment #40702 "40702 - Percent of"

What is 160% of 90?

5) Assisment #40703 "40703 - Percent of"

What is 180% of 90?

6) Assisment #40704 "40704 - Percent of"

What is 120% of 60?

7) Assisment #40705 "40705 - Percent of"

What is 110% of 90?

8) Assisment #40706 "40706 - Percent of"

What is 170% of 50?

9) Assisment #40707 "40707 - Percent of"

What is 140% of 90?

10) Assisment #40708 "40708 - Percent of"
What is 170% of 90?

11) Assisment #40709 "40709 - Percent of"
What is 110% of 70?

12) Assisment #40710 "40710 - Percent of"
What is 160% of 90?

13) Assisment #40711 "40711 - Percent of"
What is 180% of 90?

14) Assisment #40712 "40712 - Percent of"
What is 170% of 80?

15) Assisment #40713 "40713 - Percent of"
What is 160% of 80?

16) Assisment #40714 "40714 - Percent of"
What is 120% of 90?

17) Assisment #40716 "40716 - Percent of"
What is 160% of 90?

18) Assisment #40715 "40715 - Percent of"
What is 140% of 60?

19) Assisment #40717 "40717 - Percent of"
What is 140% of 80?

20) Assisment #40718 "40718 - Percent of"
What is 140% of 80?

21) Assisment #40719 "40719 - Percent of"
What is 160% of 50?

22) Assisment #40720 "40720 - Percent of"
What is 110% of 60?

23) Assisment #40721 "40721 - Percent of"
What is 120% of 90?

24) Assisment #40722 "40722 - Percent of"
What is 120% of 90?

25) Assisment #40723 "40723 - Percent of"
What is 150% of 70?

26) Assisment #40724 "40724 - Percent of"
What is 140% of 70?

27) Assisment #40725 "40725 - Percent of"
What is 180% of 60?

28) Assisment #40726 "40726 - Percent of"
What is 160% of 70?

29) Assisment #40727 "40727 - Percent of"
What is 150% of 70?

Problem Set 7196 "Least Common Multiple - THE SKILL BUILDING SET" id:[7196]

1) Assistent #47536 "47536 - Least Common Multiple"

What is the **least common multiple** of 4 and 8?

2) Assistent #47537 "47537 - Least Common Multiple"

What is the **least common multiple** of 3 and 9?

3) Assistent #47538 "47538 - Least Common Multiple"

What is the **least common multiple** of 6 and 3?

4) Assistent #47539 "47539 - Least Common Multiple"

What is the **least common multiple** of 6 and 4?

5) Assistent #47540 "47540 - Least Common Multiple"

What is the **least common multiple** of 8 and 5?

6) Assistent #47541 "47541 - Least Common Multiple"

What is the **least common multiple** of 9 and 6?

7) Assistent #47542 "47542 - Least Common Multiple"

What is the **least common multiple** of 10 and 2?

9) Assistent #47544 "47544 - Least Common Multiple"

What is the **least common multiple** of 2 and 12?

10) Assistent #47545 "47545 - Least Common Multiple"

What is the **least common multiple** of 4 and 8?

11) Assistent #47546 "47546 - Least Common Multiple"

What is the **least common multiple** of 4 and 8?

12) Assistent #47547 "47547 - Least Common Multiple"

What is the **least common multiple** of 3 and 9?

13) Assistent #47548 "47548 - Least Common Multiple"

What is the **least common multiple** of 6 and 3?

14) Assistent #47549 "47549 - Least Common Multiple"

What is the **least common multiple** of 6 and 4?

15) Assistent #47550 "47550 - Least Common Multiple"

What is the **least common multiple** of 8 and 5?

16) Assistent #47551 "47551 - Least Common Multiple"

What is the **least common multiple** of 9 and 6?

18) Assistent #47553 "47553 - Least Common Multiple"

What is the **least common multiple** of 6 and 5?

19) Assistent #47554 "47554 - Least Common Multiple"

What is the **least common multiple** of 2 and 12?

20) Assistent #47555 "47555 - Least Common Multiple"

What is the **least common multiple** of 4 and 8?

21) Assistent #47556 "47556 - Least Common Multiple"

What is the **least common multiple** of 4 and 8?

22) Assistent #47557 "47557 - Least Common Multiple"

What is the **least common multiple** of 3 and 9?

23) Assistent #47558 "47558 - Least Common Multiple"

What is the **least common multiple** of 6 and 3?

24) Assistent #47559 "47559 - Least Common Multiple"

What is the **least common multiple** of 6 and 4?

25) Assistent #47560 "47560 - Least Common Multiple"

What is the **least common multiple** of 8 and 5?

27) Assistent #47562 "47562 - Least Common Multiple"

What is the **least common multiple** of 10 and 2?

28) Assistent #47563 "47563 - Least Common Multiple"

What is the **least common multiple** of 6 and 5?

29) Assistent #47564 "47564 - Least Common Multiple"

What is the **least common multiple** of 2 and 12?

30) Assistent #47565 "47565 - Least Common Multiple"

What is the **least common multiple** of 4 and 8?

31) Assistent #47566 "47566 - Least Common Multiple"

What is the **least common multiple** of 4 and 8?

32) Assistent #47567 "47567 - Least Common Multiple"

What is the **least common multiple** of 3 and 9?

33) Assistent #47568 "47568 - Least Common Multiple"

What is the **least common multiple** of 6 and 3?

34) Assistent #47569 "47569 - Least Common Multiple"

What is the **least common multiple** of 6 and 4?

36) Assistent #47571 "47571 - Least Common Multiple"

What is the **least common multiple** of 9 and 6?

37) Assistent #47572 "47572 - Least Common Multiple"

What is the **least common multiple** of 10 and 2?

Problem Set 15296 "Composition of Functions Substitution THE SKILL BUILDING SET "

id:[15296]

1) Assistent #117934 "117934 - 107585 - Composition of Functions - Substitution (x squared)"

Suppose you have:

$$g = 6 + 3v$$

$$v = 3x + 4x^2$$

What is g in terms of x?

2) Assistent #117935 "117935 - 107585 - Composition of Functions - Substitution (x squared)"

Suppose you have:

$$c = 6 + 4r$$

$$r = 2x + 2x^2$$

What is c in terms of x?

3) Assistent #117936 "117936 - 107585 - Composition of Functions - Substitution (x squared)"

Suppose you have:

$$y = 2 + 4z$$

$$z = 3x + 3x^2$$

What is y in terms of x?

4) Assistent #117937 "117937 - 107585 - Composition of Functions - Substitution (x squared)"

Suppose you have:

$$g = 14 + 4v$$

$$v = 4x + 3x^2$$

What is g in terms of x?

5) Assistent #117938 "117938 - 107585 - Composition of Functions - Substitution (x squared)"

Suppose you have:

$$m = 5 + 3h$$

$$h = 3x + 2x^2$$

What is m in terms of x?

6) Assistent #117939 "117939 - 107585 - Composition of Functions - Substitution (x squared)"

Suppose you have:

$$i = 11 + 3j$$

$$j = 2x + 3x^2$$

What is i in terms of x?

7) Assistent #117940 "117940 - 107585 - Composition of Functions - Substitution (x squared)"

Suppose you have:

$$c = 14 + 2h$$

$$h = 2x + 3x^2$$

What is c in terms of x?

8) Assistent #117941 "117941 - 107585 - Composition of Functions - Substitution (x squared)"

Suppose you have:

$$u = 10 + 2v$$

$$v = 3x + 4x^2$$

What is u in terms of x?

9) Assistent #117942 "117942 - 107585 - Composition of Functions - Substitution (x squared)"

Suppose you have:

$$e = 4 + 4z$$

$$z = 2x + 3x^2$$

What is e in terms of x?

10) Assistent #117943 "117943 - 107585 - Composition of Functions - Substitution (x squared)"

Suppose you have:

$$i = 6 + 2x$$

$$x = 3x + 2x^2$$

What is i in terms of x?

11) Assistent #117944 "117944 - 107585 - Composition of Functions - Substitution (x squared)"

Suppose you have:

$$e = 14 + 4b$$

$$b = 2x + 3x^2$$

What is e in terms of x?

12) Assistent #117945 "117945 - 107585 - Composition of Functions - Substitution (x squared)"

Suppose you have:

$$o = 12 + 2j$$

$$j = 4x + 2x^2$$

What is o in terms of x?

13) Assistent #117946 "117946 - 107585 - Composition of Functions - Substitution (x squared)"

Suppose you have:

$$y = 9 + 3r$$

$$r = 4x + 3x^2$$

What is y in terms of x?

14) Assistent #117947 "117947 - 107585 - Composition of Functions - Substitution (x squared)"

Suppose you have:

$$u = 12 + 2b$$

$$b = 4x + 4x^2$$

What is u in terms of x?

15) Assistent #117948 "117948 - 107585 - Composition of Functions - Substitution (x squared)"

Suppose you have:

$$w = 6 + 3n$$

$$n = 2x + 4x^2$$

What is w in terms of x?

16) Assistent #117949 "117949 - 107585 - Composition of Functions - Substitution (x squared)"

Suppose you have:

$$q = 2 + 2r$$

$$r = 3x + 4x^2$$

What is q in terms of x?

17) Assistent #117950 "117950 - 107585 - Composition of Functions - Substitution (x squared)"

Suppose you have:

$$y = 5 + 3t$$

$$t = 4x + 3x^2$$

What is y in terms of x?

18) Assistent #117951 "117951 - 107585 - Composition of Functions - Substitution (x squared)"

Suppose you have:

$$o = 7 + 4r$$

$$r = 3x + 4x^2$$

What is o in terms of x?

19) Assistent #117952 "117952 - 107585 - Composition of Functions - Substitution (x squared)"

Suppose you have:

$$u = 8 + 3h$$

$$h = 2x + 2x^2$$

What is u in terms of x?

20) Assistent #117953 "117953 - 107585 - Composition of Functions - Substitution (x squared)"

Suppose you have:

$$y = 14 + 2d$$

$$d = 4x + 3x^2$$

What is y in terms of x?

21) Assistent #117954 "117954 - 107585 - Composition of Functions - Substitution (x squared)"

Suppose you have:

$$s = 12 + 3n$$

$$n = 3x + 4x^2$$

What is s in terms of x?

22) Assistent #117955 "117955 - 107585 - Composition of Functions - Substitution (x squared)"

Suppose you have:

$$i = 13 + 2h$$

$$h = 3x + 4x^2$$

What is i in terms of x?

23) Assistent #117956 "117956 - 107585 - Composition of Functions - Substitution (x squared)"

Suppose you have:

$$i = 1 + 2v$$

$$v = 3x + 4x^2$$

What is i in terms of x?

24) Assistent #117957 "117957 - 107585 - Composition of Functions - Substitution (x squared)"

Suppose you have:

$$g = 8 + 3f$$

$$f = 2x + 3x^2$$

What is g in terms of x ?

25) Assistent #117958 "117958 - Composition of Functions - Substitution (Solve an Equation)"

Brian bought a lamp with a \$58 gift card. The lamp was \$ x off and the sales tax added \$3 to the cost (C). The original price of the lamp was \$32.

$$C = (32 - x) + 3$$

$$\text{Remaining money on gift card} = 58 - C$$

Determine how much money Brian has left on the gift card in terms of x .

26) Assistent #117959 "117959 - Composition of Functions - Substitution (Solve an Equation)"

Ashley bought a wallet with a \$95 gift card. The wallet was \$ x off and the sales tax added \$4 to the cost (C). The original price of the wallet was \$57.

$$C = (57 - x) + 4$$

$$\text{Remaining money on gift card} = 95 - C$$

Determine how much money Ashley has left on the gift card in terms of x .

27) Assistent #117960 "117960 - Composition of Functions - Substitution (Solve an Equation)"

Candace bought a stereo with a \$63 gift card. The stereo was \$ x off and the sales tax added \$3 to the cost (C). The original price of the stereo was \$34.

$$C = (34 - x) + 3$$

$$\text{Remaining money on gift card} = 63 - C$$

Determine how much money Candace has left on the gift card in terms of x .

28) Assistent #117961 "117961 - Composition of Functions - Substitution (Solve an Equation)"

Casey bought a backpack with a \$96 gift card. The backpack was \$ x off and the sales tax added \$2 to the cost (C). The original price of the backpack was \$51.

$$C = (51 - x) + 2$$

Remaining money on gift card = $96 - C$

Determine how much money Casey has left on the gift card in terms of x .

29) Assistent #117962 "117962 - Composition of Functions - Substitution (Solve an Equation)"

Brian bought a lamp with a \$52 gift card. The lamp was $\$x$ off and the sales tax added \$4 to the cost (C). The original price of the lamp was \$24.

$$C = (24 - x) + 4$$

Remaining money on gift card = $52 - C$

Determine how much money Brian has left on the gift card in terms of x .

30) Assistent #117963 "117963 - Composition of Functions - Substitution (Solve an Equation)"

Ashley bought a wallet with a \$83 gift card. The wallet was $\$x$ off and the sales tax added \$3 to the cost (C). The original price of the wallet was \$40.

$$C = (40 - x) + 3$$

Remaining money on gift card = $83 - C$

Determine how much money Ashley has left on the gift card in terms of x .

31) Assistent #117964 "117964 - Composition of Functions - Substitution (Solve an Equation)"

Kevin bought a watch with a \$82 gift card. The watch was $\$x$ off and the sales tax added \$2 to the cost (C). The original price of the watch was \$20.

$$C = (20 - x) + 2$$

Remaining money on gift card = $82 - C$

Determine how much money Kevin has left on the gift card in terms of x .

32) Assistent #117965 "117965 - Composition of Functions - Substitution (Solve an Equation)"

Brian bought a lamp with a \$79 gift card. The lamp was $\$x$ off and the sales tax added \$3 to the cost (C). The original price of the lamp was \$27.

$$C = (27 - x) + 3$$

Remaining money on gift card = $79 - C$

Determine how much money Brian has left on the gift card in terms of x .

33) Assisment #117966 "117966 - Composition of Functions - Substitution (Solve an Equation)"

Candace bought a stereo with a \$94 gift card. The stereo was \$x off and the sales tax added \$2 to the cost (C). The original price of the stereo was \$24.

$$C = (24 - x) + 2$$

$$\text{Remaining money on gift card} = 94 - C$$

Determine how much money Candace has left on the gift card in terms of x.

34) Assisment #117967 "117967 - Composition of Functions - Substitution (Solve an Equation)"

Casey bought a backpack with a \$68 gift card. The backpack was \$x off and the sales tax added \$2 to the cost (C). The original price of the backpack was \$47.

$$C = (47 - x) + 2$$

$$\text{Remaining money on gift card} = 68 - C$$

Determine how much money Casey has left on the gift card in terms of x.

35) Assisment #117968 "117968 - Composition of Functions - Substitution (Solve an Equation)"

Ashley bought a wallet with a \$73 gift card. The wallet was \$x off and the sales tax added \$4 to the cost (C). The original price of the wallet was \$51.

$$C = (51 - x) + 4$$

$$\text{Remaining money on gift card} = 73 - C$$

Determine how much money Ashley has left on the gift card in terms of x.

36) Assisment #117969 "117969 - Composition of Functions - Substitution (Solve an Equation)"

Dina bought a DVD with a \$97 gift card. The DVD was \$x off and the sales tax added \$3 to the cost (C). The original price of the DVD was \$25.

$$C = (25 - x) + 3$$

$$\text{Remaining money on gift card} = 97 - C$$

Determine how much money Dina has left on the gift card in terms of x.

37) Assisment #117970 "117970 - Composition of Functions - Substitution (Solve an Equation)"

Brian bought a lamp with a \$50 gift card. The lamp was \$x off and the sales tax added \$4

to the cost (C). The original price of the lamp was \$57.

$$C = (57 - x) + 4$$

$$\text{Remaining money on gift card} = 50 - C$$

Determine how much money Brian has left on the gift card in terms of x.

38) Assistent #117971 "117971 - Composition of Functions - Substitution (Solve an Equation)"

Brian bought a lamp with a \$89 gift card. The lamp was \$x off and the sales tax added \$4 to the cost (C). The original price of the lamp was \$52.

$$C = (52 - x) + 4$$

$$\text{Remaining money on gift card} = 89 - C$$

Determine how much money Brian has left on the gift card in terms of x.

39) Assistent #117972 "117972 - Composition of Functions - Substitution (Solve an Equation)"

Carl bought a backpack with a \$82 gift card. The backpack was \$x off and the sales tax added \$4 to the cost (C). The original price of the backpack was \$20.

$$C = (20 - x) + 4$$

$$\text{Remaining money on gift card} = 82 - C$$

Determine how much money Carl has left on the gift card in terms of x.

40) Assistent #117973 "117973 - Composition of Functions - Substitution (Solve an Equation)"

Bill bought a sweater with a \$69 gift card. The sweater was \$x off and the sales tax added \$3 to the cost (C). The original price of the sweater was \$34.

$$C = (34 - x) + 3$$

$$\text{Remaining money on gift card} = 69 - C$$

Determine how much money Bill has left on the gift card in terms of x.

41) Assistent #117974 "117974 - Composition of Functions - Substitution (Solve an Equation)"

Bill bought a sweater with a \$76 gift card. The sweater was \$x off and the sales tax added \$4 to the cost (C). The original price of the sweater was \$58.

$$C = (58 - x) + 4$$

$$\text{Remaining money on gift card} = 76 - C$$

Determine how much money Bill has left on the gift card in terms of x.

42) Assistent #117975 "117975 - Composition of Functions - Substitution (Solve an Equation)"

Brian bought a lamp with a \$88 gift card. The lamp was \$x off and the sales tax added \$2 to the cost (C). The original price of the lamp was \$48.

$$C = (48 - x) + 2$$

$$\text{Remaining money on gift card} = 88 - C$$

Determine how much money Brian has left on the gift card in terms of x.

43) Assistent #117976 "117976 - Composition of Functions - Substitution (Solve an Equation)"

Candace bought a stereo with a \$58 gift card. The stereo was \$x off and the sales tax added \$4 to the cost (C). The original price of the stereo was \$55.

$$C = (55 - x) + 4$$

$$\text{Remaining money on gift card} = 58 - C$$

Determine how much money Candace has left on the gift card in terms of x.

44) Assistent #117977 "117977 - Composition of Functions - Substitution (Solve an Equation)"

Brian bought a lamp with a \$86 gift card. The lamp was \$x off and the sales tax added \$2 to the cost (C). The original price of the lamp was \$42.

$$C = (42 - x) + 2$$

$$\text{Remaining money on gift card} = 86 - C$$

Determine how much money Brian has left on the gift card in terms of x.

45) Assistent #117978 "117978 - Composition of Functions - Substitution (Solve an Equation)"

Betty bought a computer game with a \$74 gift card. The computer game was \$x off and the sales tax added \$4 to the cost (C). The original price of the computer game was \$27.

$$C = (27 - x) + 4$$

$$\text{Remaining money on gift card} = 74 - C$$

Determine how much money Betty has left on the gift card in terms of x.

46) Assistent #117979 "117979 - Composition of Functions - Substitution (Solve an

Equation)"

Brian bought a lamp with a \$91 gift card. The lamp was \$x off and the sales tax added \$4 to the cost (C). The original price of the lamp was \$29.

$$C = (29 - x) + 4$$

$$\text{Remaining money on gift card} = 91 - C$$

Determine how much money Brian has left on the gift card in terms of x.

47) Assistent #117980 "117980 - Composition of Functions - Substitution (Solve an Equation)"

Kevin bought a watch with a \$89 gift card. The watch was \$x off and the sales tax added \$3 to the cost (C). The original price of the watch was \$51.

$$C = (51 - x) + 3$$

$$\text{Remaining money on gift card} = 89 - C$$

Determine how much money Kevin has left on the gift card in terms of x.

48) Assistent #117981 "117981 - Composition of Functions - Substitution (Solve an Equation)"

Candace bought a stereo with a \$92 gift card. The stereo was \$x off and the sales tax added \$3 to the cost (C). The original price of the stereo was \$28.

$$C = (28 - x) + 3$$

$$\text{Remaining money on gift card} = 92 - C$$

Determine how much money Candace has left on the gift card in terms of x.

49) Assistent #117982 "117982 - Composition of Functions - Substitution (nothing squared)"

Suppose you have:

$$s = 5 + 2j$$

$$j = 3x$$

What is s in terms of x?

50) Assistent #117984 "117984 - Composition of Functions - Substitution (nothing squared)"

Suppose you have:

$$o = 4 + 2t$$

$$t = 2x$$

What is o in terms of x?

51) Assistent #117985 "117985 - Composition of Functions - Substitution (nothing squared)"

Suppose you have:

$$c = 14 + 2d$$

$$d = 2x$$

What is c in terms of x ?

52) Assistent #117986 "117986 - Composition of Functions - Substitution (nothing squared)"

Suppose you have:

$$i = 8 + 3x$$

$$x = 3x$$

What is i in terms of x ?

53) Assistent #117987 "117987 - Composition of Functions - Substitution (nothing squared)"

Suppose you have:

$$o = 5 + 2z$$

$$z = 2x$$

What is o in terms of x ?

54) Assistent #117988 "117988 - Composition of Functions - Substitution (nothing squared)"

Suppose you have:

$$m = 2 + 2l$$

$$l = 3x$$

What is m in terms of x ?

55) Assistent #117989 "117989 - Composition of Functions - Substitution (nothing squared)"

Suppose you have:

$$g = 5 + 3t$$

$$t = 3x$$

What is g in terms of x ?

56) Assistent #117990 "117990 - Composition of Functions - Substitution (nothing squared)"

Suppose you have:

$$g = 1 + 4n$$

$$n = 3x$$

What is g in terms of x ?

57) Assistent #117991 "117991 - Composition of Functions - Substitution (nothing squared)"

Suppose you have:

$$o = 12 + 4f$$

$$f = 4x$$

What is o in terms of x ?

58) Assistent #117992 "117992 - Composition of Functions - Substitution (nothing squared)"

Suppose you have:

$$g = 5 + 2j$$

$$j = 4x$$

What is g in terms of x ?

59) Assistent #117993 "117993 - Composition of Functions - Substitution (nothing squared)"

Suppose you have:

$$o = 2 + 4t$$

$$t = 2x$$

What is o in terms of x ?

60) Assistent #117994 "117994 - Composition of Functions - Substitution (nothing squared)"

Suppose you have:

$$w = 14 + 2b$$

$$b = 2x$$

What is w in terms of x ?

61) Assistent #117995 "117995 - Composition of Functions - Substitution (nothing squared)"

Suppose you have:

$$s = 10 + 2r$$

$$r = 3x$$

What is s in terms of x ?

62) Assistent #117996 "117996 - Composition of Functions - Substitution (nothing squared)"

Suppose you have:

$$s = 5 + 3r$$

$$r = 4x$$

What is s in terms of x ?

63) Assistent #117997 "117997 - Composition of Functions - Substitution (nothing squared)"

Suppose you have:

$$e = 9 + 2t$$

$$t = 2x$$

What is e in terms of x ?

64) Assistent #117998 "117998 - Composition of Functions - Substitution (nothing squared)"

Suppose you have:

$$i = 2 + 2f$$

$$f = 4x$$

What is i in terms of x ?

65) Assistent #117999 "117999 - Composition of Functions - Substitution (nothing squared)"

Suppose you have:

$$k = 8 + 4t$$

$$t = 2x$$

What is k in terms of x ?

66) Assisment #118000 "118000 - Composition of Functions - Substitution (nothing squared)"

Suppose you have:

$$i = 4 + 2b$$

$$b = 3x$$

What is i in terms of x ?

67) Assisment #118001 "118001 - Composition of Functions - Substitution (nothing squared)"

Suppose you have:

$$a = 4 + 4d$$

$$d = 4x$$

What is a in terms of x ?

68) Assisment #118002 "118002 - Composition of Functions - Substitution (nothing squared)"

Suppose you have:

$$o = 4 + 4b$$

$$b = 2x$$

What is o in terms of x ?

69) Assisment #118003 "118003 - Composition of Functions - Substitution (nothing squared)"

Suppose you have:

$$q = 7 + 4f$$

$$f = 4x$$

What is q in terms of x ?

70) Assisment #118004 "118004 - Composition of Functions - Substitution (nothing squared)"

Suppose you have:

$$k = 1 + 2t$$

$$t = 2x$$

What is k in terms of x ?

71) Assisment #118005 "118005 - Composition of Functions - Substitution (nothing squared)"

Suppose you have:

$$w = 11 + 2j$$

$$j = 4x$$

What is w in terms of x ?

72) Assisment #118006 "118006 - Composition of Functions - Substitution (nothing squared)"

$$d = 4x$$

What is e in terms of x ?

73) Assistent #118007 "118007 - 114865 - Composition of Functions - Substitution (nothing squared subtraction)"

Suppose you have:

$$w = 14 - 2v$$

$$v = 2x$$

What is w in terms of x ?

74) Assistent #118008 "118008 - 114865 - Composition of Functions - Substitution (nothing squared subtraction)"

Suppose you have:

$$u = 2 - 4n$$

$$n = 2x$$

What is u in terms of x ?

75) Assistent #118009 "118009 - 114865 - Composition of Functions - Substitution (nothing squared subtraction)"

Suppose you have:

$$o = 4 - 3p$$

$$p = 2x$$

What is o in terms of p ?

76) Assistent #118010 "118010 - 114865 - Composition of Functions - Substitution (nothing squared subtraction)"

Suppose you have:

$$k = 3 - 2z$$

$$z = 2x$$

What is k in terms of x ?

77) Assistent #118011 "118011 - 114865 - Composition of Functions - Substitution (nothing squared subtraction)"

Suppose you have:

$$u = 12 - 2b$$

$$b = 4x$$

What is u in terms of x ?

78) Assistent #118012 "118012 - 114865 - Composition of Functions - Substitution (nothing squared subtraction)"

Suppose you have:

$$y = 14 - 3n$$

$$n = 4x$$

What is y in terms of x ?

79) Assistent #118013 "118013 - 114865 - Composition of Functions - Substitution (nothing squared subtraction)"

Suppose you have:

$$o = 13 - 2n$$

$$n = 3x$$

What is o in terms of x ?

80) Assistent #118014 "118014 - 114865 - Composition of Functions - Substitution (nothing squared subtraction)"

Suppose you have:

$$m = 1 - 2l$$

$$l = 4x$$

What is m in terms of x ?

81) Assistent #118015 "118015 - 114865 - Composition of Functions - Substitution (nothing squared subtraction)"

Suppose you have:

$$g = 6 - 2n$$

$$n = 2x$$

What is g in terms of x ?

82) Assistent #118016 "118016 - 114865 - Composition of Functions - Substitution (nothing squared subtraction)"

Suppose you have:

$$w = 9 - 2d$$

$$d = 4x$$

What is w in terms of x ?

83) Assistent #118017 "118017 - 114865 - Composition of Functions - Substitution (nothing squared subtraction)"

Suppose you have:

$$a = 8 - 3b$$

$$b = 3x$$

What is a in terms of x ?

84) Assistent #118018 "118018 - 114865 - Composition of Functions - Substitution (nothing squared subtraction)"

Suppose you have:

$$m = 8 - 3d$$

$$d = 2x$$

What is m in terms of x ?

85) Assistent #118019 "118019 - 114865 - Composition of Functions - Substitution (nothing squared subtraction)"

Suppose you have:

$$w = 2 - 2j$$

$$j = 4x$$

What is w in terms of x ?

86) Assistent #118020 "118020 - 114865 - Composition of Functions - Substitution (nothing squared subtraction)"

Suppose you have:

$$w = 9 - 4y$$

$$y = 4x$$

What is w in terms of x ?

87) Assistent #118021 "118021 - 114865 - Composition of Functions - Substitution (nothing squared subtraction)"

Suppose you have:

$$i = 1 - 3l$$

$$l = 2x$$

What is i in terms of x ?

88) Assistent #118022 "118022 - 114865 - Composition of Functions - Substitution (nothing squared subtraction)"

Suppose you have:

$$a = 7 - 4h$$

$$h = 2x$$

What is a in terms of x ?

89) Assistent #118024 "118024 - 114865 - Composition of Functions - Substitution (nothing squared subtraction)"

Suppose you have:

$$y = 11 - 4t$$

$$t = 4x$$

What is y in terms of x ?

90) Assistent #118025 "118025 - 114865 - Composition of Functions - Substitution (nothing squared subtraction)"

Suppose you have:

$$m = 9 - 2f$$

$$f = 4x$$

What is m in terms of x ?

91) Assisment #118026 "118026 - 114865 - Composition of Functions - Substitution (nothing squared subtraction)"

Suppose you have:

$$u = 1 - 2r$$

$$r = 4x$$

What is u in terms of x ?

92) Assisment #118027 "118027 - 114865 - Composition of Functions - Substitution (nothing squared subtraction)"

Suppose you have:

$$w = 12 - 4j$$

$$j = 4x$$

What is w in terms of x ?

93) Assisment #118028 "118028 - 114865 - Composition of Functions - Substitution (nothing squared subtraction)"

Suppose you have:

$$s = 1 - 2n$$

$$n = 4x$$

What is s in terms of x ?

94) Assisment #118029 "118029 - 114865 - Composition of Functions - Substitution (nothing squared subtraction)"

Suppose you have:

$$y = 3 - 4b$$

$$b = 4x$$

What is y in terms of x ?

95) Assisment #118030 "118030 - 114865 - Composition of Functions - Substitution (nothing squared subtraction)"

Suppose you have:

$$u = 13 - 4l$$

$$l = 3x$$

What is u in terms of x ?

96) Assisment #118031 "118031 - 114865 - Composition of Functions - Substitution (nothing squared subtraction)"

Suppose you have:

$$c = 6 - 2z$$

$$z = 4x$$

What is c in terms of x ?

97) Assisment #118032 "118032 - 114866 - Composition of Functions - Substitution (x

squared subtraction)"

Suppose you have:

$$g = 3t + 11$$

$$t = 2x - 2x^2$$

What is g in terms of x ?

98) Assistent #118033 "118033 - 114866 - Composition of Functions - Substitution (x squared subtraction)"

Suppose you have:

$$c = 4x + 3$$

$$x = 2x - 3x^2$$

What is c in terms of x ?

99) Assistent #118034 "118034 - 114866 - Composition of Functions - Substitution (x squared subtraction)"

Suppose you have:

$$s = 4t + 4$$

$$t = 4x - 4x^2$$

What is s in terms of x ?

100) Assistent #118035 "118035 - 114866 - Composition of Functions - Substitution (x squared subtraction)"

Suppose you have:

$$m = 3t + 12$$

$$t = 2x - 2x^2$$

What is m in terms of x ?

101) Assistent #118036 "118036 - 114866 - Composition of Functions - Substitution (x squared subtraction)"

Suppose you have:

$$q = 3p + 8$$

$$p = 3x - 3x^2$$

What is q in terms of x ?

102) Assistent #118037 "118037 - 114866 - Composition of Functions - Substitution (x squared subtraction)"

Suppose you have:

$$a = 4x + 2$$

$$x = 3x - 3x^2$$

What is a in terms of x ?

103) Assistent #118038 "118038 - 114866 - Composition of Functions - Substitution (x squared subtraction)"

Suppose you have:

$$s = 4x + 6$$

$$x = 3x - 2x^2$$

What is s in terms of x ?

104) Assistent #118039 "118039 - 114866 - Composition of Functions - Substitution (x squared subtraction)"

Suppose you have:

$$w = 2v + 9$$

$$v = 3x - 4x^2$$

What is w in terms of x ?

105) Assistent #118040 "118040 - 114866 - Composition of Functions - Substitution (x squared subtraction)"

Suppose you have:

$$a = 4h + 5$$

$$h = 2x - 4x^2$$

What is a in terms of x ?

106) Assistent #118041 "118041 - 114866 - Composition of Functions - Substitution (x squared subtraction)"

Suppose you have:

$$w = 2p + 4$$

$$p = 2x - 4x^2$$

What is w in terms of x ?

107) Assistent #118042 "118042 - 114866 - Composition of Functions - Substitution (x squared subtraction)"

Suppose you have:

$$e = 3r + 2$$

$$r = 4x - 4x^2$$

What is e in terms of x ?

108) Assistent #118043 "118043 - 114866 - Composition of Functions - Substitution (x squared subtraction)"

Suppose you have:

$$c = 3r + 7$$

$$r = 4x - 2x^2$$

What is c in terms of x ?

109) Assistent #118044 "118044 - 114866 - Composition of Functions - Substitution (x squared subtraction)"

Suppose you have:

$$u = 2f + 14$$

$$f = 4x - 4x^2$$

What is u in terms of x ?

110) Assistent #118045 "118045 - 114866 - Composition of Functions - Substitution (x squared subtraction)"

Suppose you have:

$$e = 2z + 4$$

$$z = 2x - 2x^2$$

What is e in terms of x ?

111) Assistent #118046 "118046 - 114866 - Composition of Functions - Substitution (x squared subtraction)"

Suppose you have:

$$m = 4t + 7$$

$$t = 3x - 3x^2$$

What is m in terms of x ?

112) Assistent #118047 "118047 - 114866 - Composition of Functions - Substitution (x squared subtraction)"

Suppose you have:

$$a = 4l + 2$$

$$l = 2x - 4x^2$$

What is a in terms of x ?

113) Assistent #118048 "118048 - 114866 - Composition of Functions - Substitution (x squared subtraction)"

Suppose you have:

$$q = 4n + 5$$

$$n = 4x - 4x^2$$

What is q in terms of x ?

114) Assistent #118049 "118049 - 114866 - Composition of Functions - Substitution (x squared subtraction)"

Suppose you have:

$$u = 3n + 10$$

$$n = 4x - 2x^2$$

What is u in terms of x ?

115) Assistent #118050 "118050 - 114866 - Composition of Functions - Substitution (x squared subtraction)"

Suppose you have:

$$s = 4d + 3$$

$$d = 4x - 3x^2$$

What is s in terms of x?

116) Assistent #118051 "118051 - 114866 - Composition of Functions - Substitution (x squared subtraction)"

Suppose you have:

$$y = 4r + 14$$

$$r = 3x - 3x^2$$

What is y in terms of x?

117) Assistent #118052 "118052 - 114866 - Composition of Functions - Substitution (x squared subtraction)"

Suppose you have:

$$w = 3d + 13$$

$$d = 2x - 2x^2$$

What is w in terms of x?

118) Assistent #118053 "118053 - 114866 - Composition of Functions - Substitution (x squared subtraction)"

Suppose you have:

$$g = 4z + 14$$

$$z = 4x - 4x^2$$

What is g in terms of x?

119) Assistent #118054 "118054 - 114866 - Composition of Functions - Substitution (x squared subtraction)"

Suppose you have:

$$g = 3d + 13$$

$$d = 4x - 3x^2$$

What is g in terms of x?

120) Assistent #118055 "118055 - 114866 - Composition of Functions - Substitution (x squared subtraction)"

Suppose you have:

$$i = 4l + 5$$

$$l = 3x - 3x^2$$

What is i in terms of x?

Problem Set 15490 "Equations from a Diagram" id:[15490]

1) Assistent #119415 "119415 - Diagram-Area -Can"

If the diameter of the can is $1x$, find the expression for the surface area of the can.

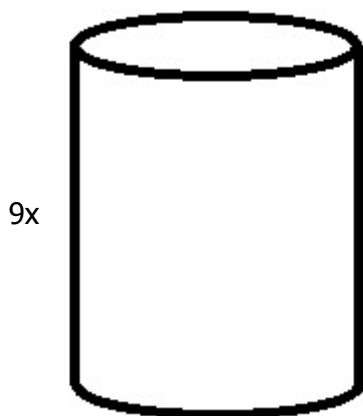

Type π in as "pi" and put any fractions in parantheses.
Ex. $4x^2+(9/5)x^2\pi+6x$

2) Assistent #119416 "119416 - Diagram-Area -Can"

If the diameter of the can is $3x$, find the expression for the surface area of the can.

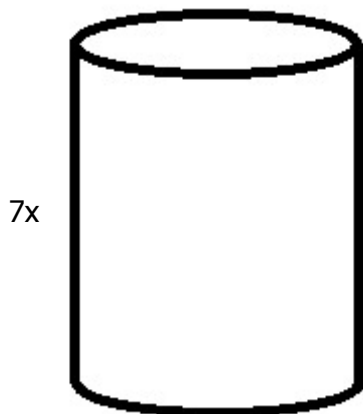

Type π in as "pi" and put any fractions in parantheses.

Ex. $4x^2 + (9/5)x^2\pi + 6x$

3) Assistent #119417 "119417 - Diagram-Area -Can"

If the diameter of the can is $1x$, find the expression for the surface area of the can.

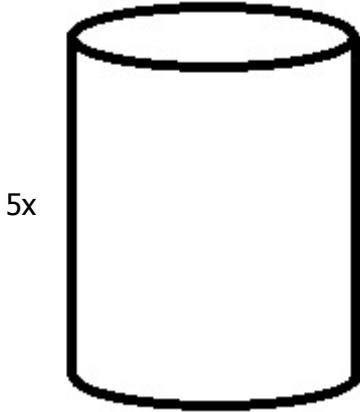

Type π in as "pi" and put any fractions in parantheses.

Ex. $4x^2 + (9/5)x^2\pi + 6x$

4) Assistent #119418 "119418 - Diagram-Area -Can"

If the diameter of the can is $1x$, find the expression for the surface area of the can.

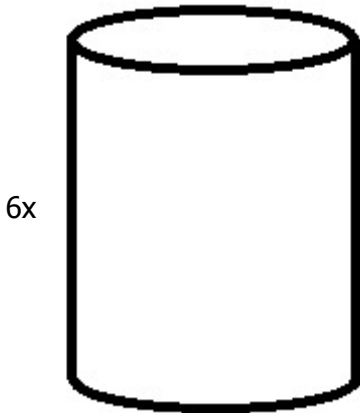

Type π in as "pi" and put any fractions in parantheses.

Ex. $4x^2 + (9/5)x^2\pi + 6x$

5) Assistent #119419 "119419 - Diagram-Area -Can"

If the diameter of the can is $3x$, find the expression for the surface area of the can.

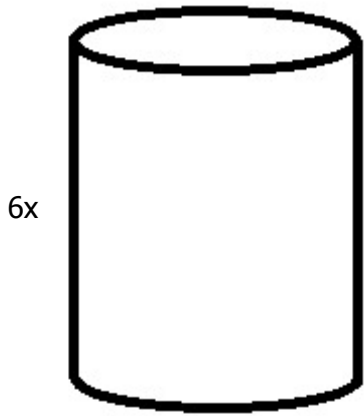

Type π in as "pi" and put any fractions in parentheses.
Ex. $4x^2+(9/5)x^2\pi+6x$

6) Assistent #119420 "119420 - Diagram-Area -Can"

If the diameter of the can is $4x$, find the expression for the surface area of the can.

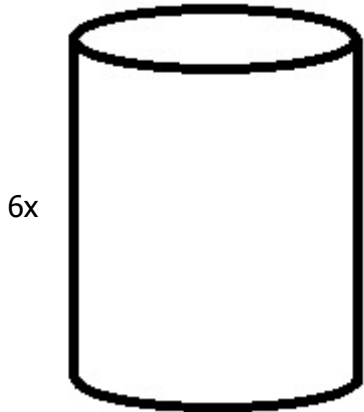

Type π in as "pi" and put any fractions in parentheses.
Ex. $4x^2+(9/5)x^2\pi+6x$

7) Assistent #119421 "119421 - Diagram-Area -Can"

If the diameter of the can is $1x$, find the expression for the surface area of the can.

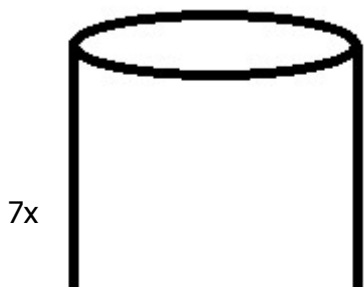



Type π in as "pi" and put any fractions in parentheses.
Ex. $4x^2+(9/5)x^2\pi+6x$

8) Assistent #119422 "119422 - Diagram-Area -Can"

If the diameter of the can is $3x$, find the expression for the surface area of the can.

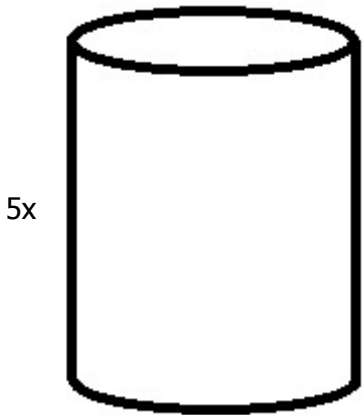

Type π in as "pi" and put any fractions in parentheses.
Ex. $4x^2+(9/5)x^2\pi+6x$

9) Assistent #119423 "119423 - Diagram-Area -Can"

If the diameter of the can is $4x$, find the expression for the surface area of the can.

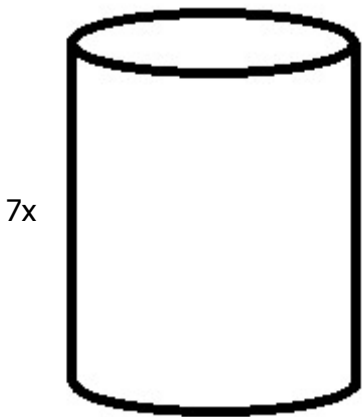

Type π in as "pi" and put any fractions in parentheses.
Ex. $4x^2+(9/5)x^2\pi+6x$

10) Assistent #119424 "119424 - Diagram-Area -Can"

If the diameter of the can is $1x$, find the expression for the surface area of the can.

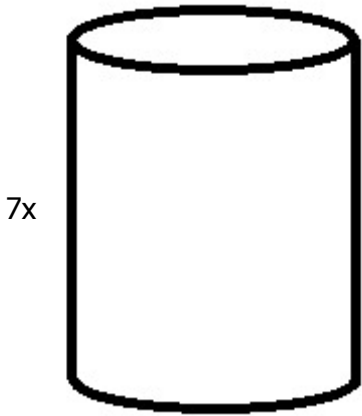

Type π in as "pi" and put any fractions in parantheses.
Ex. $4x^2+(9/5)x^2\pi+6x$

11) Assistent #119425 "119425 - Diagram-Area -Can"

If the diameter of the can is $1x$, find the expression for the surface area of the can.

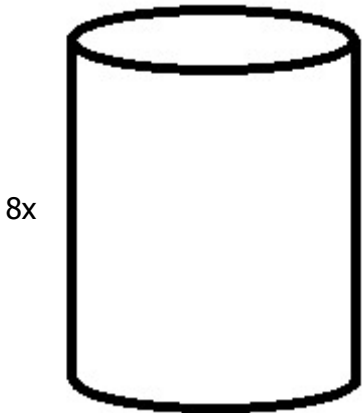

Type π in as "pi" and put any fractions in parantheses.
Ex. $4x^2+(9/5)x^2\pi+6x$

12) Assistent #119426 "119426 - Diagram-Area -Can"

If the diameter of the can is $2x$, find the expression for the surface area of the can.



8x

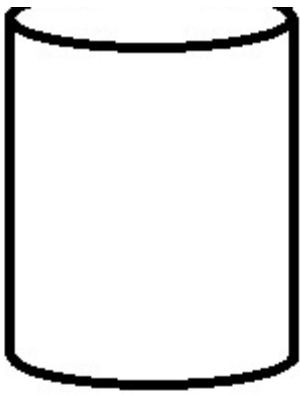

Type π in as "pi" and put any fractions in parentheses.
Ex. $4x^2+(9/5)x^2\pi+6x$

13) Assistent #119427 "119427 - Diagram-Area -Can"

If the diameter of the can is $2x$, find the expression for the surface area of the can.

6x

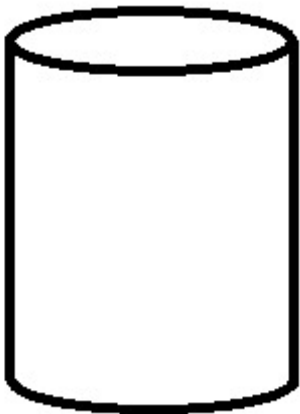

Type π in as "pi" and put any fractions in parentheses.
Ex. $4x^2+(9/5)x^2\pi+6x$

14) Assistent #119428 "119428 - Diagram-Area -Can"

If the diameter of the can is $2x$, find the expression for the surface area of the can.

9x

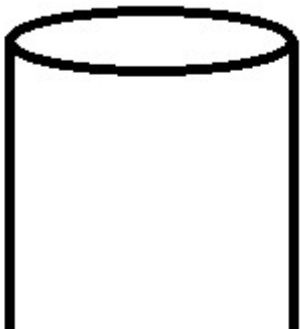



Type π in as "pi" and put any fractions in parentheses.
Ex. $4x^2+(9/5)x^2\pi+6x$

15) Assistent #119429 "119429 - Diagram-Area -Can"

If the diameter of the can is $1x$, find the expression for the surface area of the can.

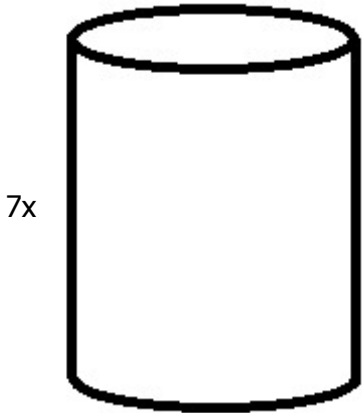

Type π in as "pi" and put any fractions in parentheses.
Ex. $4x^2+(9/5)x^2\pi+6x$

16) Assistent #119430 "119430 - Diagram-Area -Can"

If the diameter of the can is $1x$, find the expression for the surface area of the can.

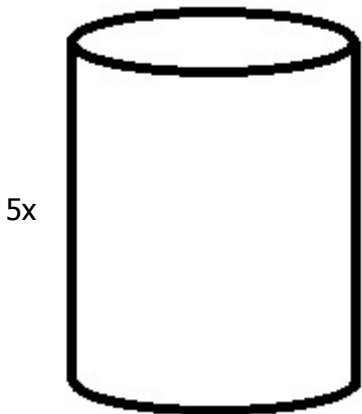

Type π in as "pi" and put any fractions in parentheses.
Ex. $4x^2+(9/5)x^2\pi+6x$

17) Assistent #119431 "119431 - Diagram-Area -Can"

If the diameter of the can is $3x$, find the expression for the surface area of the can.

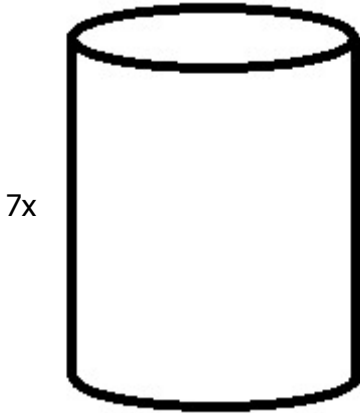

Type π in as "pi" and put any fractions in parantheses.

Ex. $4x^2+(9/5)x^2\pi+6x$

18) Assistent #119432 "119432 - Diagram-Area -Can"

If the diameter of the can is $4x$, find the expression for the total surface area of the can. This includes the top an bottom of the can, as well as the label area.

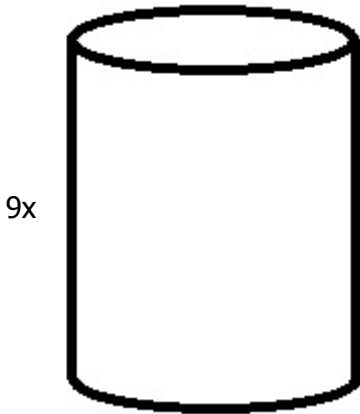

Type π in as "pi" and put any fractions in parantheses.

Ex. $4x^2+(9/5)x^2\pi+6x$

19) Assistent #119433 "119433 - Diagram-Area -Can"

If the diameter of the can is $3x$, find the expression for the surface area of the can.



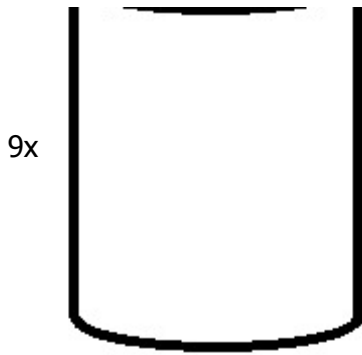

Type π in as "pi" and put any fractions in parentheses.
 Ex. $4x^2 + (9/5)x^2\pi + 6x$

20) Assistent #119434 "119434 - Diagram-Area -Can"

If the diameter of the can is $3x$, find the expression for the surface area of the can.

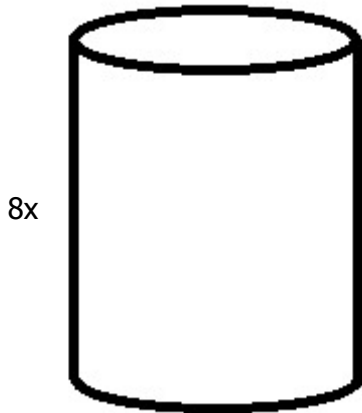

Type π in as "pi" and put any fractions in parentheses.
 Ex. $4x^2 + (9/5)x^2\pi + 6x$

21) Assistent #119435 "119435 - 107739 - Diagram-Area -Track"

Below is the diagram of the school's track. The shape is a rectangle with two half circles at each end.

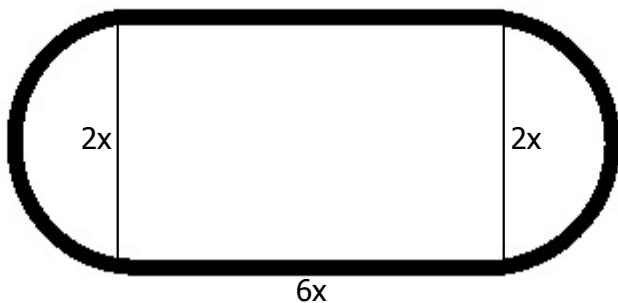

Write an expression for the interior area.

Type π in as "pi" and put any fractions in parentheses.

Ex. $4x^2 + (9/5)x^2\pi + 6x$

22) Assisment #119436 "119436 - 107739 - Diagram-Area -Track"

Below is the diagram of the school's track. The shape is a rectangle with two half circles at each end.

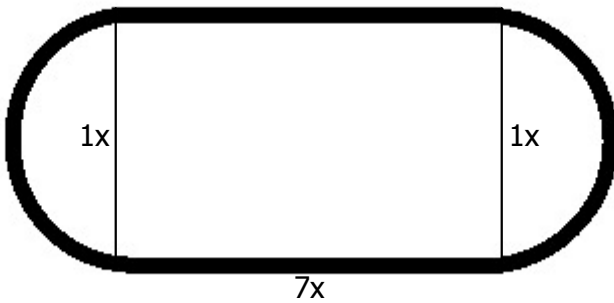

Write an expression for the interior area.

Type π in as "pi" and put any fractions in parentheses.

Ex. $4x^2 + (9/5)x^2\pi + 6x$

23) Assisment #119437 "119437 - 107739 - Diagram-Area -Track"

Below is the diagram of the school's track. The shape is a rectangle with two half circles at each end.

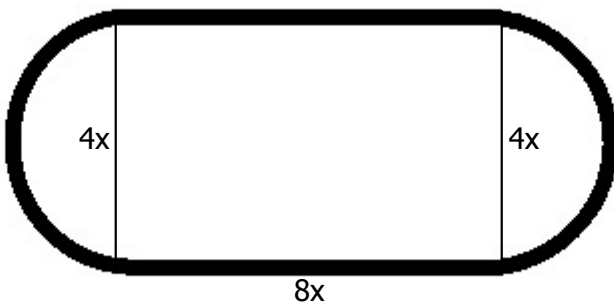

Write an expression for the interior area.

Type π in as "pi" and put any fractions in parentheses.

Ex. $4x^2 + (9/5)x^2\pi + 6x$

24) Assistent #119438 "119438 - 107739 - Diagram-Area -Track"

Below is the diagram of the school's track. The shape is a rectangle with two half circles at each end.

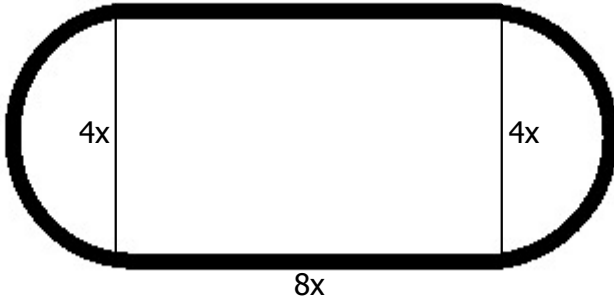

Write an expression for the interior area.

Type π in as "pi" and put any fractions in parantheses.

Ex. $4x^2+(9/5)x^2\pi+6x$

25) Assistent #119439 "119439 - 107739 - Diagram-Area -Track"

Below is the diagram of the school's track. The shape is a rectangle with two half circles at each end.

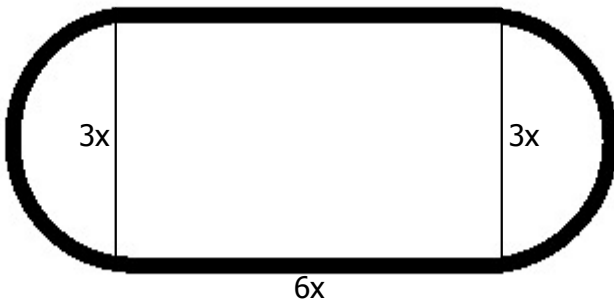

Write an expression for the interior area.

Type π in as "pi" and put any fractions in parantheses.

Ex. $4x^2+(9/5)x^2\pi+6x$

26) Assistent #119440 "119440 - 107739 - Diagram-Area -Track"

Below is the diagram of the school's track. The shape is a rectangle with two half circles at each end.

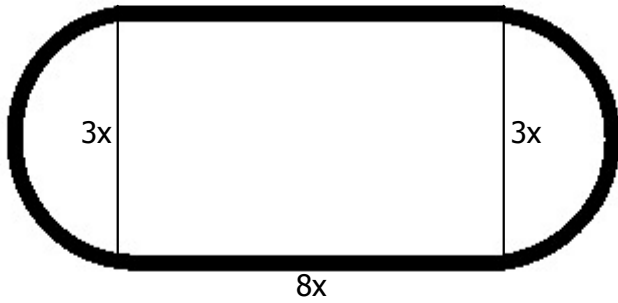

Write an expression for the interior area.

Type π in as "pi" and put any fractions in parentheses.

Ex. $4x^2 + (9/5)x^2\pi + 6x$

27) Assisment #119441 "119441 - 107739 - Diagram-Area -Track"

Below is the diagram of the school's track. The shape is a rectangle with two half circles at each end.

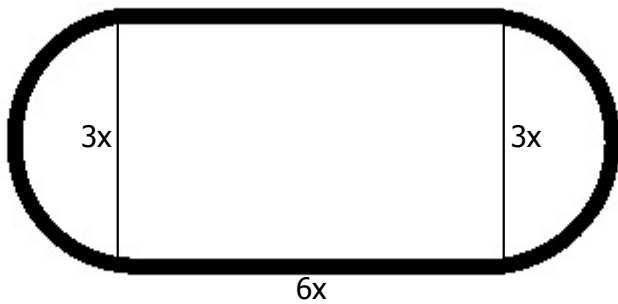

Write an expression for the interior area.

Type π in as "pi" and put any fractions in parentheses.

Ex. $4x^2 + (9/5)x^2\pi + 6x$

28) Assisment #119442 "119442 - 107739 - Diagram-Area -Track"

Below is the diagram of the school's track. The shape is a rectangle with two half circles at each end.



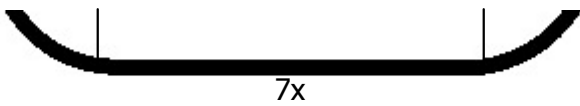

Write an expression for the interior area.

Type π in as "pi" and put any fractions in parentheses.

Ex. $4x^2+(9/5)x^2\pi+6x$

29) Assistent #119443 "119443 - 107739 - Diagram-Area -Track"

Below is the diagram of the school's track. The shape is a rectangle with two half circles at each end.

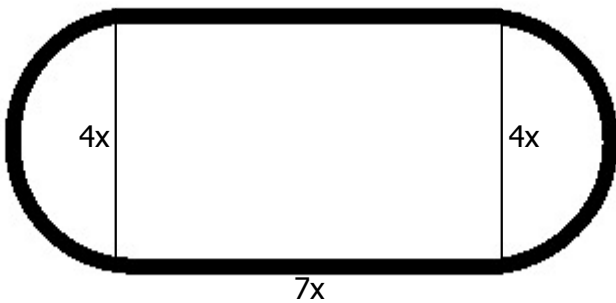

Write an expression for the interior area.

Type π in as "pi" and put any fractions in parentheses.

Ex. $4x^2+(9/5)x^2\pi+6x$

30) Assistent #119444 "119444 - 107739 - Diagram-Area -Track"

Below is the diagram of the school's track. The shape is a rectangle with two half circles at each end.

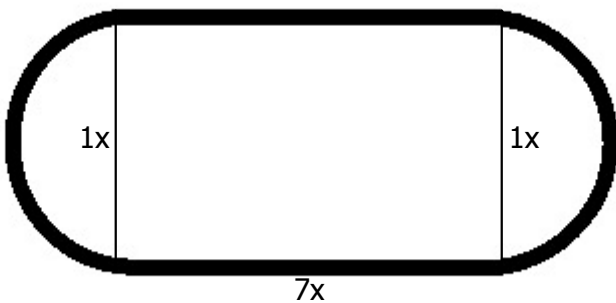

Write an expression for the interior area.

Type π in as "pi" and put any fractions in parentheses.

Ex. $4x^2 + (9/5)x^2\pi + 6x$

31) Assistent #119445 "119445 - 107739 - Diagram-Area -Track"

Below is the diagram of the school's track. The shape is a rectangle with two half circles at each end.

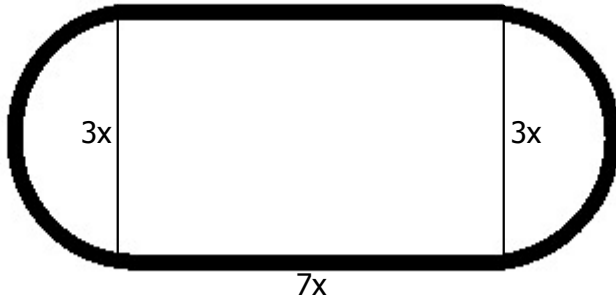

Write an expression for the interior area.

Type π in as "pi" and put any fractions in parantheses.

Ex. $4x^2 + (9/5)x^2\pi + 6x$

32) Assistent #119446 "119446 - 107739 - Diagram-Area -Track"

Below is the diagram of the school's track. The shape is a rectangle with two half circles at each end.

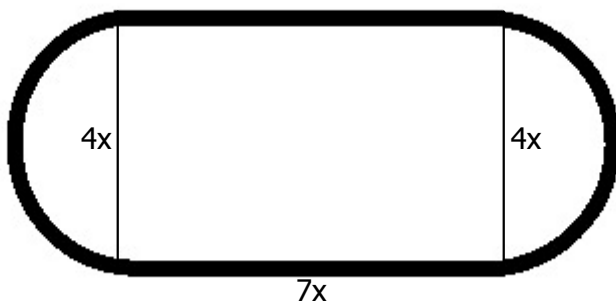

Write an expression for the interior area.

Type π in as "pi" and put any fractions in parantheses.

Ex. $4x^2 + (9/5)x^2\pi + 6x$

33) Assistent #119447 "119447 - 107739 - Diagram-Area -Track"

Below is the diagram of the school's track. The shape is a rectangle with two half circles at each end.

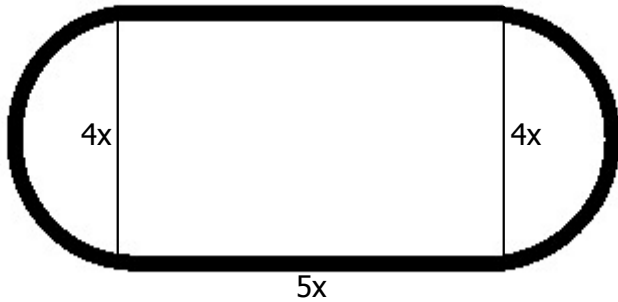

Write an expression for the interior area.

Type π in as "pi" and put any fractions in parentheses.

Ex. $4x^2 + (9/5)x^2\pi + 6x$

34) Assisment #119448 "119448 - 107739 - Diagram-Area -Track"

Below is the diagram of the school's track. The shape is a rectangle with two half circles at each end.

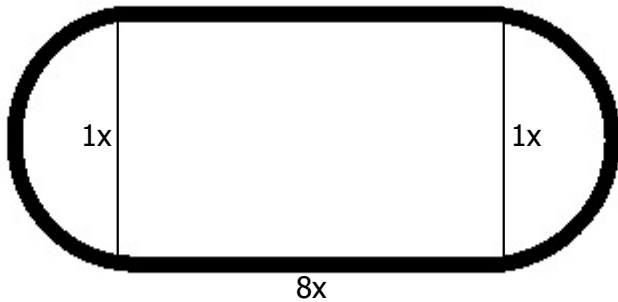

Write an expression for the interior area.

Type π in as "pi" and put any fractions in parentheses.

Ex. $4x^2 + (9/5)x^2\pi + 6x$

35) Assisment #119449 "119449 - 107739 - Diagram-Area -Track"

Below is the diagram of the school's track. The shape is a rectangle with two half circles at each end.



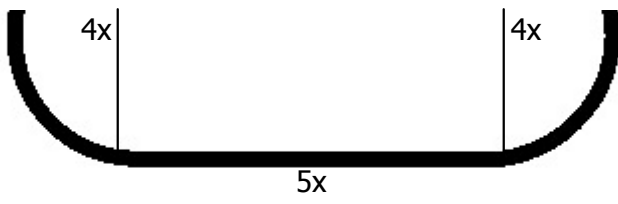

Write an expression for the interior area.

Type π in as "pi" and put any fractions in parentheses.

Ex. $4x^2 + (9/5)x^2\pi + 6x$

36) Assistent #119450 "119450 - 107739 - Diagram-Area -Track"

Below is the diagram of the school's track. The shape is a rectangle with two half circles at each end.

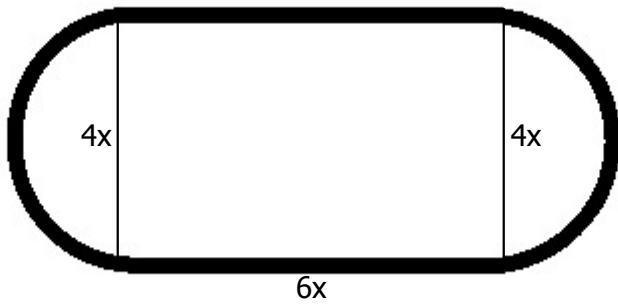

Write an expression for the interior area.

Type π in as "pi" and put any fractions in parentheses.

Ex. $4x^2 + (9/5)x^2\pi + 6x$

37) Assistent #119451 "119451 - 107739 - Diagram-Area -Track"

Below is the diagram of the school's track. The shape is a rectangle with two half circles at each end.

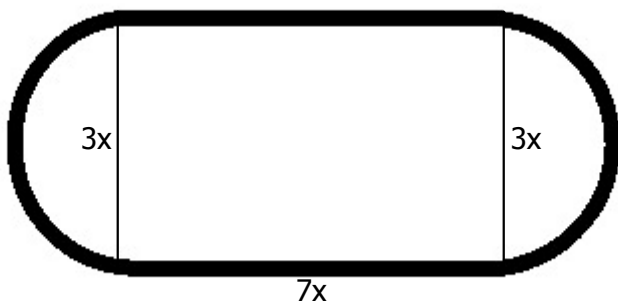

Write an expression for the interior area.

Type π in as "pi" and put any fractions in parentheses.

Ex. $4x^2 + (9/5)x^2\pi + 6x$

38) Assistent #119452 "119452 - 107739 - Diagram-Area -Track"

Below is the diagram of the school's track. The shape is a rectangle with two half circles at each end.

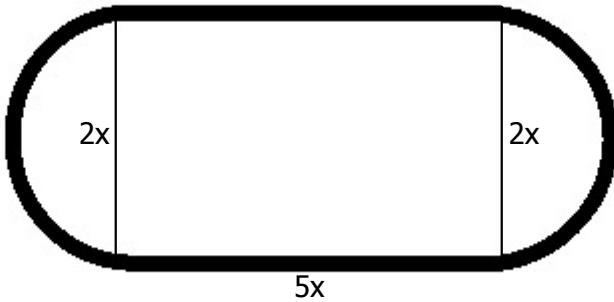

Write an expression for the interior area.

Type π in as "pi" and put any fractions in parentheses.

Ex. $4x^2 + (9/5)x^2\pi + 6x$

39) Assistent #119453 "119453 - 107739 - Diagram-Area -Track"

Below is the diagram of the school's track. The shape is a rectangle with two half circles at each end.

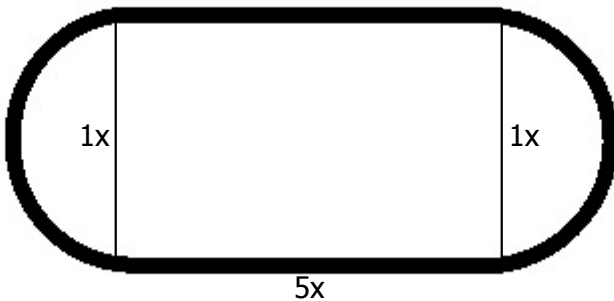

Write an expression for the interior area.

Type π in as "pi" and put any fractions in parentheses.

Ex. $4x^2 + (9/5)x^2\pi + 6x$

40) Assistent #119454 "119454 - 107739 - Diagram-Area-Track"

Below is the diagram of the school's track. The shape is a rectangle with two half circles at each end.

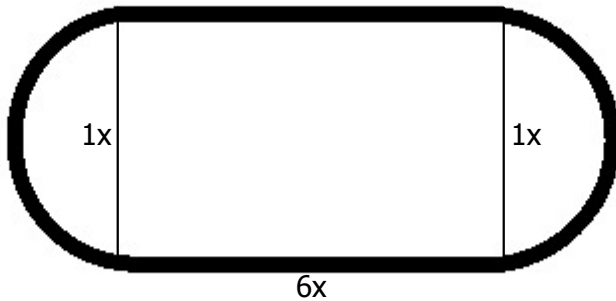

Write an expression for the interior area.

Type π in as "pi" and put any fractions in parantheses.

Ex. $4x^2+(9/5)x^2\pi+6x$

41) Assistent #119455 "119455 - 107740 - Diagram-Perimeter-Track"

Below is the diagram of the school's track. The shape is a rectangle with two half circles at each end.

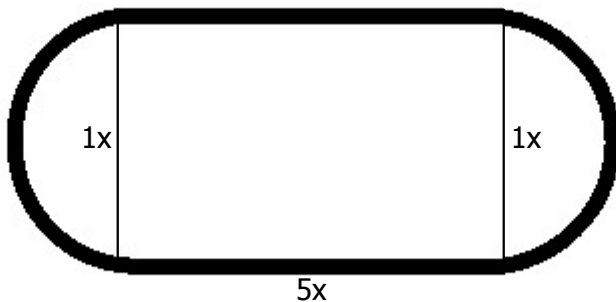

Write an expression for the perimeter of this figure.

Type π in as "pi" and put any fractions in parantheses.

Ex. $4x^2+(9/5)x^2\pi+6x$

42) Assistent #119456 "119456 - 107740 - Diagram-Perimeter-Track"

Below is the diagram of the school's track. The shape is a rectangle with two half circles at each end.

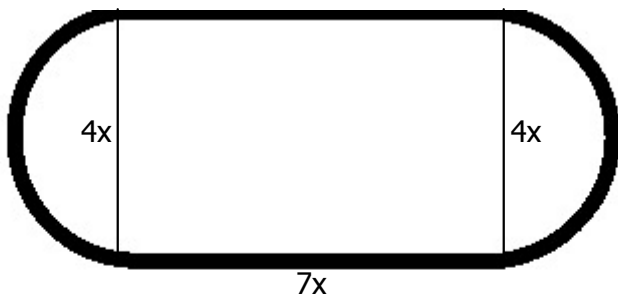

Write an expression for the perimeter of this figure.

Type π in as "pi" and put any fractions in parentheses.
Ex. $4x^2 + (9/5)x^2\pi + 6x$

43) Assistent #119457 "119457 - 107740 - Diagram-Perimeter-Track"

Below is the diagram of the school's track. The shape is a rectangle with two half circles at each end.

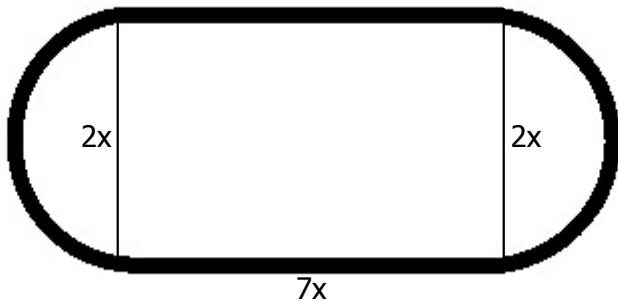

Write an expression for the perimeter of this figure.

Type π in as "pi" and put any fractions in parentheses.
Ex. $4x^2 + (9/5)x^2\pi + 6x$

44) Assistent #119458 "119458 - 107740 - Diagram-Perimeter-Track"

Below is the diagram of the school's track. The shape is a rectangle with two half circles at each end.



$$8x$$

Write an expression for the perimeter of this figure.

Type π in as "pi" and put any fractions in parentheses.
Ex. $4x^2+(9/5)x^2\pi+6x$

45) Assistent #119459 "119459 - 107740 - Diagram-Perimeter-Track"

Below is the diagram of the school's track. The shape is a rectangle with two half circles at each end.

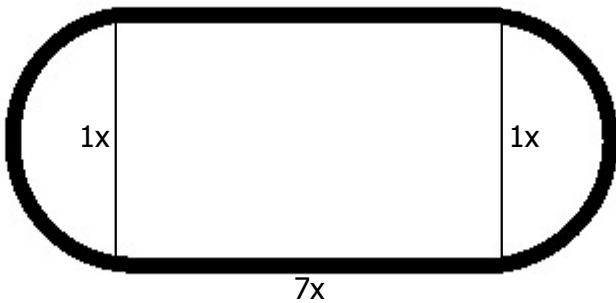

Write an expression for the perimeter of this figure.

Type π in as "pi" and put any fractions in parentheses.
Ex. $4x^2+(9/5)x^2\pi+6x$

46) Assistent #119460 "119460 - 107740 - Diagram-Perimeter-Track"

Below is the diagram of the school's track. The shape is a rectangle with two half circles at each end.

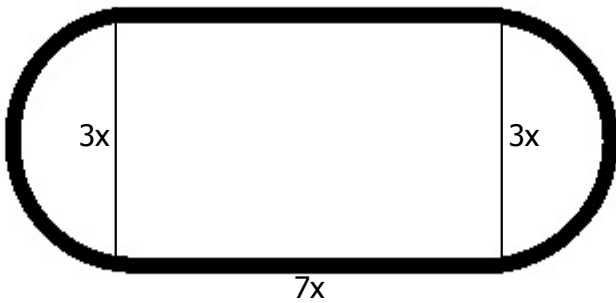

Write an expression for the perimeter of this figure.

Type π in as "pi" and put any fractions in parentheses.
Ex. $4x^2+(9/5)x^2\pi+6x$

47) Assistent #119461 "119461 - 107740 - Diagram-Perimeter-Track"

Below is the diagram of the school's track. The shape is a rectangle with two half circles at each end.

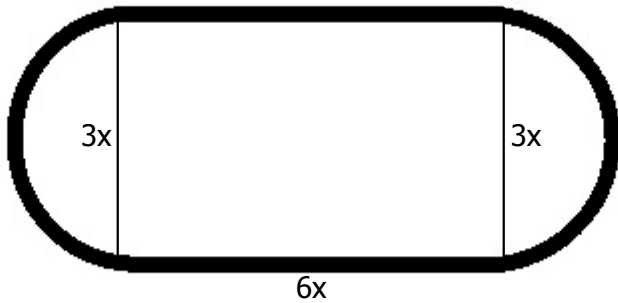

Write an expression for the perimeter of this figure.

Type π in as "pi" and put any fractions in parantheses.

Ex. $4x^2+(9/5)x^2\pi+6x$

48) Assistent #119462 "119462 - 107740 - Diagram-Perimeter-Track"

Below is the diagram of the school's track. The shape is a rectangle with two half circles at each end.

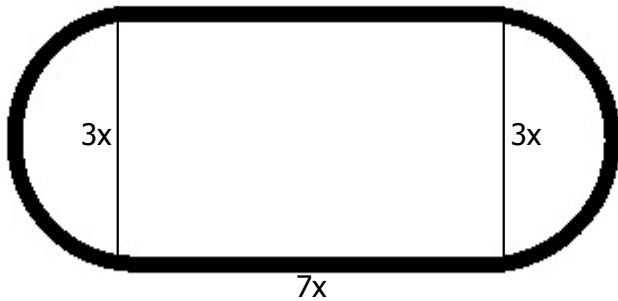

Write an expression for the perimeter of this figure.

Type π in as "pi" and put any fractions in parantheses.

Ex. $4x^2+(9/5)x^2\pi+6x$

49) Assistent #119463 "119463 - 107740 - Diagram-Perimeter-Track"

Below is the diagram of the school's track. The shape is a rectangle with two half circles at each end.

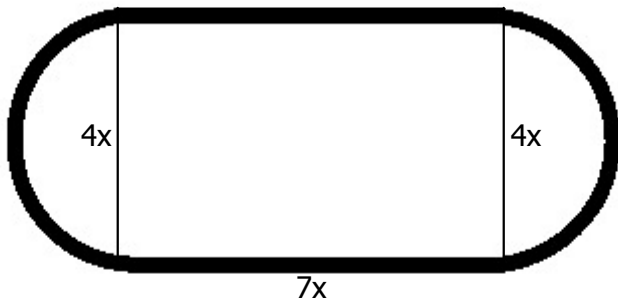

Write an expression for the perimeter of this figure.

Type π in as "pi" and put any fractions in parentheses.
 Ex. $4x^2 + (9/5)x^2\pi + 6x$

50) Assisment #119464 "119464 - 107740 - Diagram-Perimeter-Track"

Below is the diagram of the school's track. The shape is a rectangle with two half circles at each end.

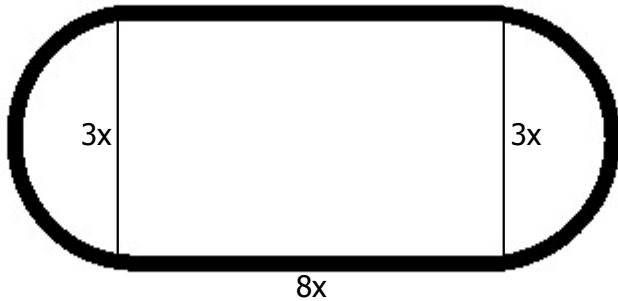

Write an expression for the perimeter of this figure.

Type π in as "pi" and put any fractions in parentheses.
 Ex. $4x^2 + (9/5)x^2\pi + 6x$

51) Assisment #119465 "119465 - 107740 - Diagram-Perimeter-Track"

Below is the diagram of the school's track. The shape is a rectangle with two half circles at each end.



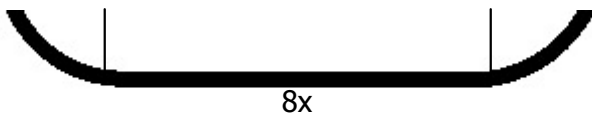

Write an expression for the perimeter of this figure.

Type π in as "pi" and put any fractions in parentheses.
 Ex. $4x^2 + (9/5)x^2\pi + 6x$

52) Assisment #119466 "119466 - 107740 - Diagram-Perimeter-Track"

Below is the diagram of the school's track. The shape is a rectangle with two half circles at each end.

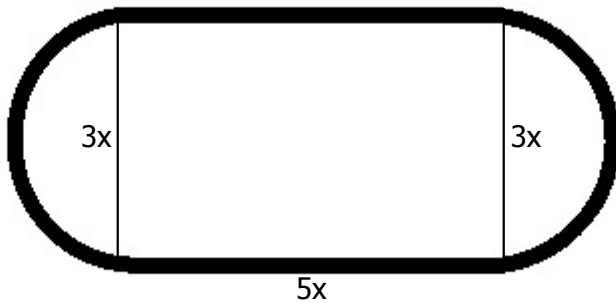

Write an expression for the perimeter of this figure.

Type π in as "pi" and put any fractions in parentheses.
 Ex. $4x^2 + (9/5)x^2\pi + 6x$

53) Assisment #119467 "119467 - 107740 - Diagram-Perimeter-Track"

Below is the diagram of the school's track. The shape is a rectangle with two half circles at each end.

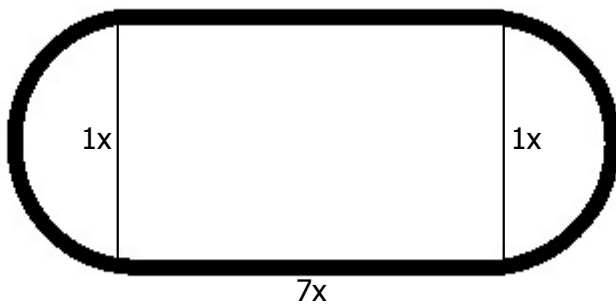

Write an expression for the perimeter of this figure.

Type π in as "pi" and put any fractions in parentheses.

Ex. $4x^2 + (9/5)x^2\pi + 6x$

54) Assistent #119468 "119468 - 107740 - Diagram-Perimeter-Track"

Below is the diagram of the school's track. The shape is a rectangle with two half circles at each end.

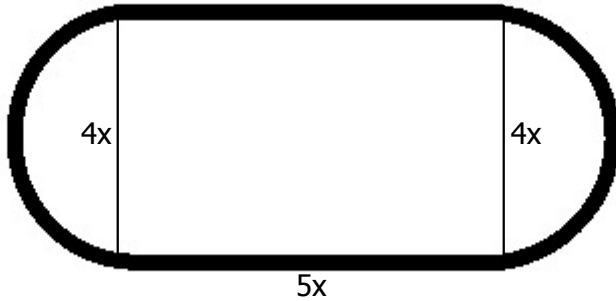

Write an expression for the perimeter of this figure.

Type π in as "pi" and put any fractions in parantheses.

Ex. $4x^2 + (9/5)x^2\pi + 6x$

55) Assistent #119469 "119469 - 107740 - Diagram-Perimeter-Track"

Below is the diagram of the school's track. The shape is a rectangle with two half circles at each end.

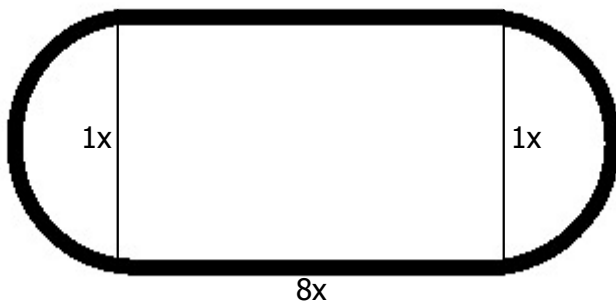

Write an expression for the perimeter of this figure.

Type π in as "pi" and put any fractions in parantheses.

Ex. $4x^2 + (9/5)x^2\pi + 6x$

56) Assistent #119470 "119470 - 107740 - Diagram-Perimeter-Track"

Below is the diagram of the school's track. The shape is a rectangle with two half circles at each end.

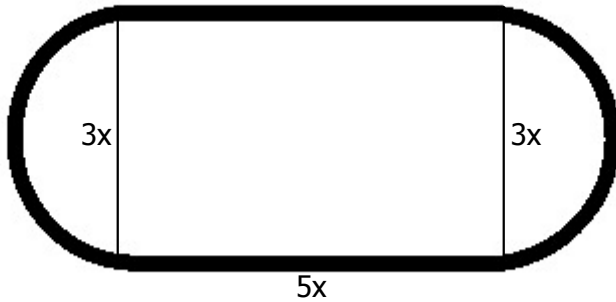

Write an expression for the perimeter of this figure.

Type π in as "pi" and put any fractions in parentheses.
Ex. $4x^2 + (9/5)x^2\pi + 6x$

57) Assistent #119471 "119471 - 107740 - Diagram-Perimeter-Track"

Below is the diagram of the school's track. The shape is a rectangle with two half circles at each end.

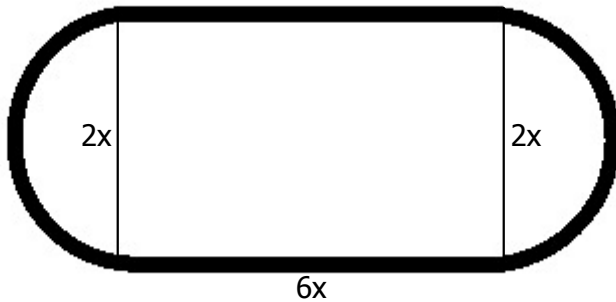

Write an expression for the perimeter of this figure.

Type π in as "pi" and put any fractions in parentheses.
Ex. $4x^2 + (9/5)x^2\pi + 6x$

58) Assistent #119472 "119472 - 107740 - Diagram-Perimeter-Track"

Below is the diagram of the school's track. The shape is a rectangle with two half circles at each end.



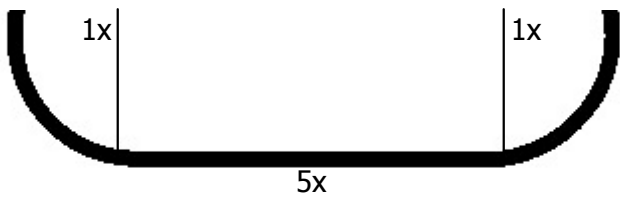

Write an expression for the perimeter of this figure.

Type π in as "pi" and put any fractions in parentheses.
 Ex. $4x^2 + (9/5)x^2\pi + 6x$

59) Assistent #119473 "119473 - 107740 - Diagram-Perimeter-Track"

Below is the diagram of the school's track. The shape is a rectangle with two half circles at each end.

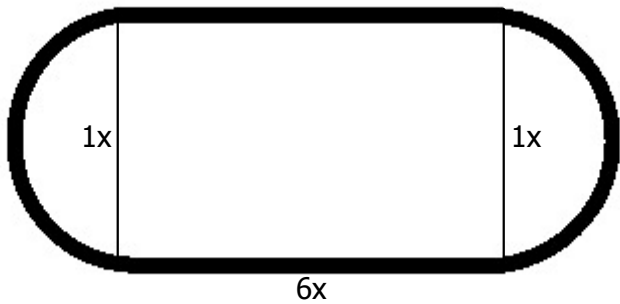

Write an expression for the perimeter of this figure.

Type π in as "pi" and put any fractions in parentheses.
 Ex. $4x^2 + (9/5)x^2\pi + 6x$

60) Assistent #119474 "119474 - 107740 - Diagram-Perimeter-Track"

Below is the diagram of the school's track. The shape is a rectangle with two half circles at each end.

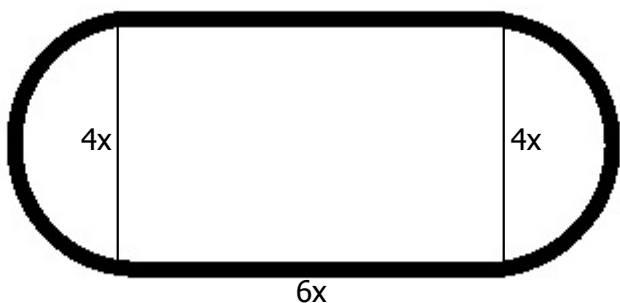

Write an expression for the perimeter of this figure.

Type π in as "pi" and put any fractions in parentheses.

Ex. $4x^2 + (9/5)x^2\pi + 6x$

61) Assistent #119475 "119475 - 116398 - Diagram-Area -Garden"

Below is an overhead view of a garden. What is the expression for the area of the garden?

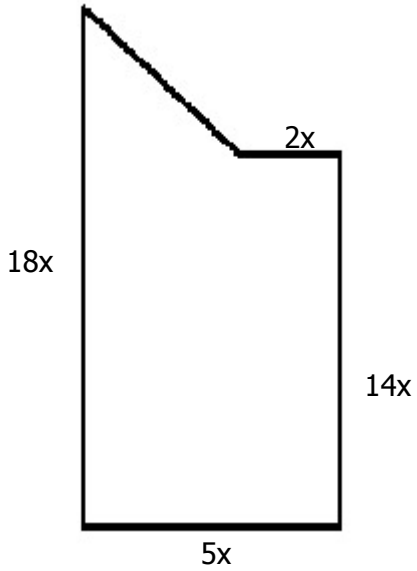

62) Assistent #119476 "119476 - 116398 - Diagram-Area -Garden"

Below is an overhead view of a garden. What is the expression for the area of the garden?

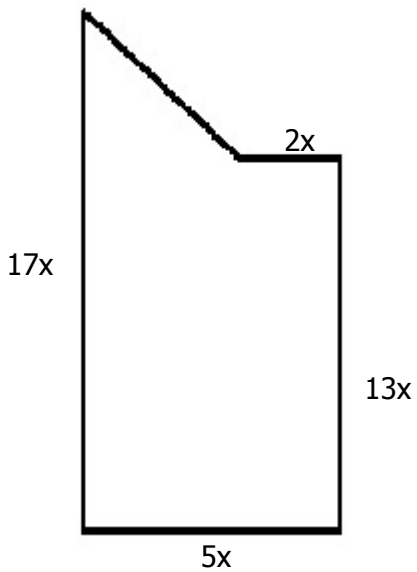

63) Assistentment #119477 "119477 - 116398 - Diagram-Area -Garden"

Below is an overhead view of a garden. What is the expression for the area of the garden?

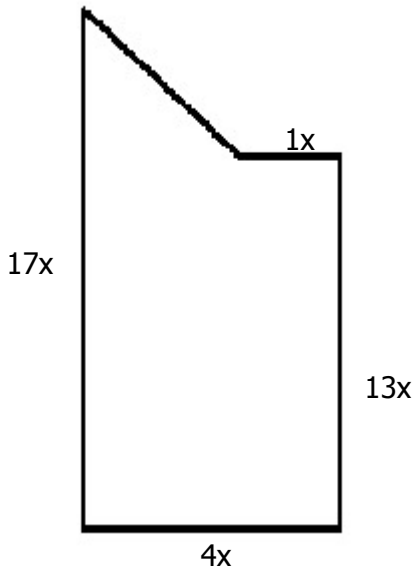

64) Assistentment #119478 "119478 - 116398 - Diagram-Area -Garden"

Below is an overhead view of a garden. What is the expression for the area of the garden?

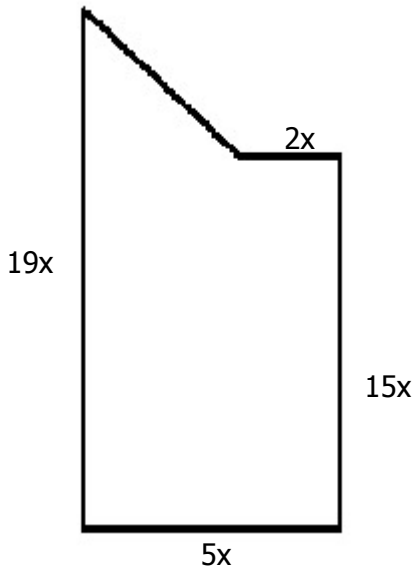

65) Assistentment #119479 "119479 - 116398 - Diagram-Area -Garden"

Below is an overhead view of a garden. What is the expression for the area of the garden?

area of the garden?

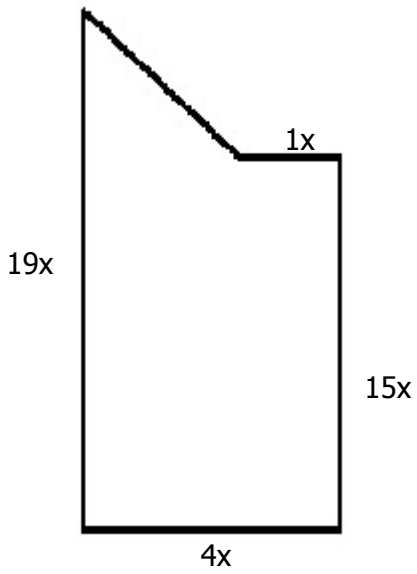

66) Assistent #119480 "119480 - 116398 - Diagram-Area -Garden"

Below is an overhead view of a garden. What is the expression for the area of the garden?

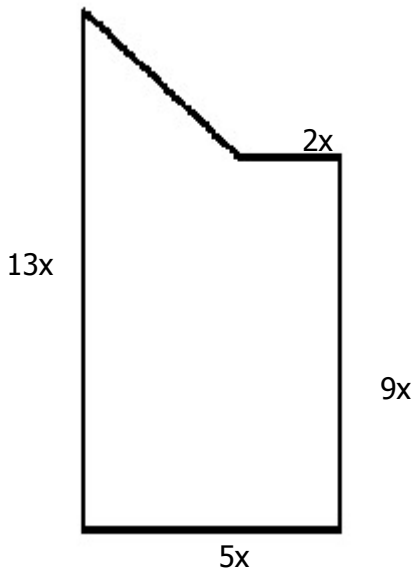

67) Assistent #119481 "119481 - 116398 - Diagram-Area -Garden"

Below is an overhead view of a garden. What is the expression for the area of the garden?



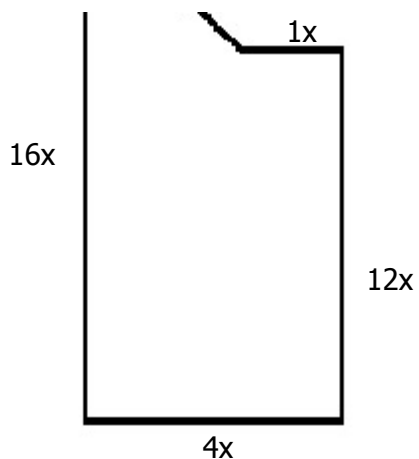

68) Assistent #119482 "119482 - 116398 - Diagram-Area -Garden"

Below is an overhead view of a garden. What is the expression for the area of the garden?

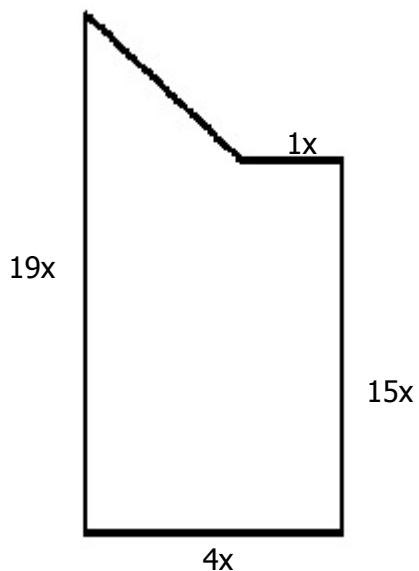

69) Assistent #119483 "119483 - 116398 - Diagram-Area -Garden"

Below is an overhead view of a garden. What is the expression for the area of the garden?

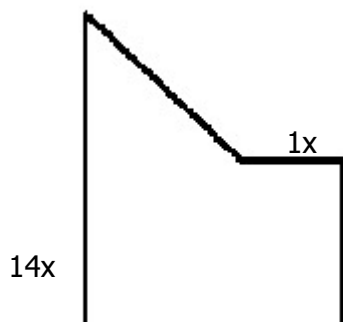

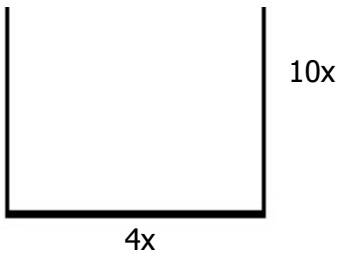

70) Assisment #119484 "119484 - 116398 - Diagram-Area -Garden"

Below is an overhead view of a garden. What is the expression for the area of the garden?

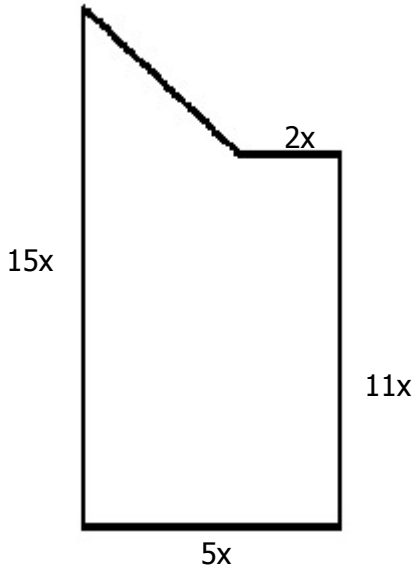

71) Assisment #119485 "119485 - 116398 - Diagram-Area -Garden"

Below is an overhead view of a garden. What is the expression for the area of the garden?

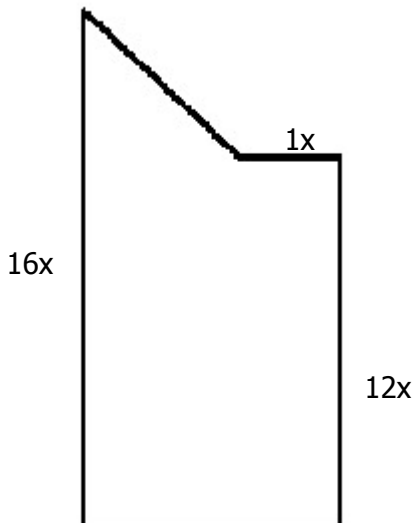

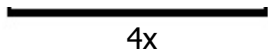

72) Assistent #119486 "119486 - 116398 - Diagram-Area -Garden"

Below is an overhead view of a garden. What is the expression for the area of the garden?

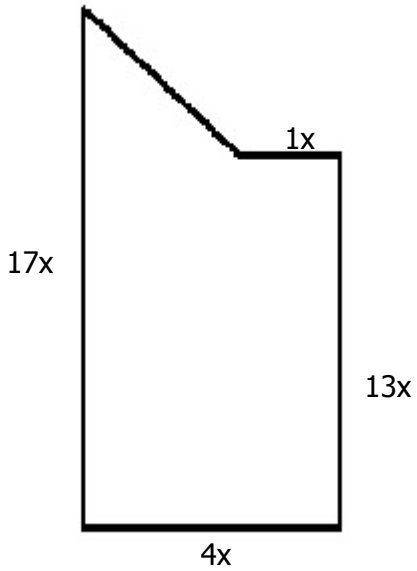

73) Assistent #119487 "119487 - 116398 - Diagram-Area -Garden"

Below is an overhead view of a garden. What is the expression for the area of the garden?

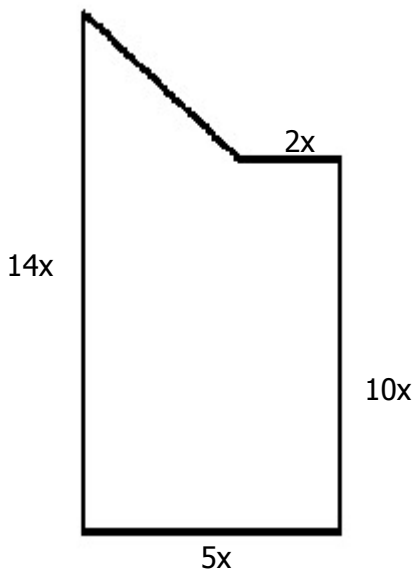

74) Assistent #119488 "119488 - 116398 - Diagram-Area -Garden"

Below is an overhead view of a garden. What is the expression for the area of the garden?

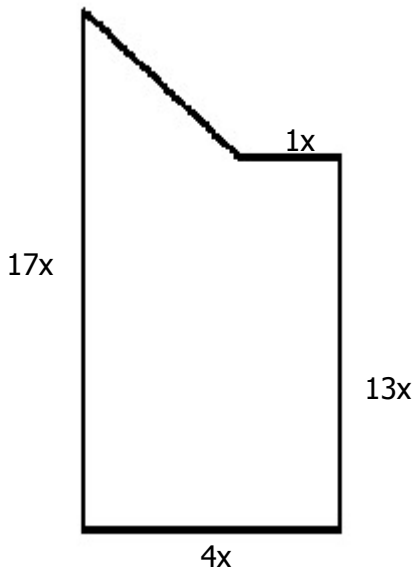

75) Assistent #119489 "119489 - 116398 - Diagram-Area -Garden"

Below is an overhead view of a garden. What is the expression for the area of the garden?

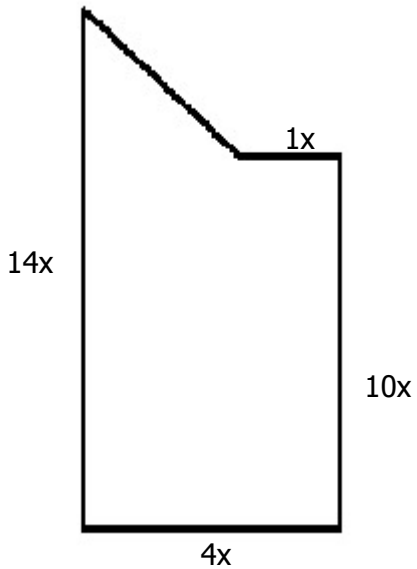

76) Assistent #119490 "119490 - 116398 - Diagram-Area -Garden"

Below is an overhead view of a garden. What is the expression for the area of the garden?



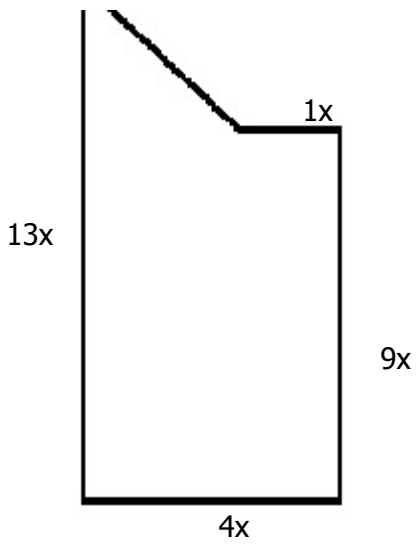

77) Assistent #119491 "119491 - 116398 - Diagram-Area -Garden"

Below is an overhead view of a garden. What is the expression for the area of the garden?

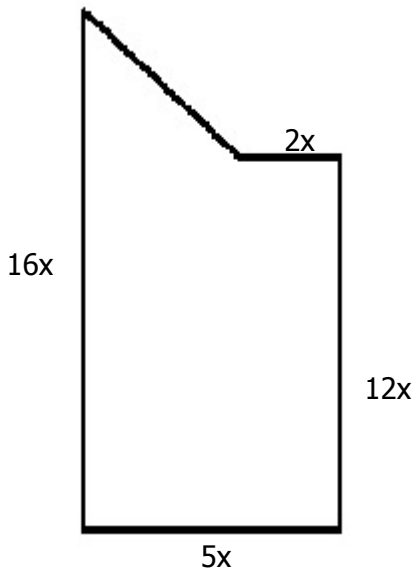

78) Assistent #119492 "119492 - 116398 - Diagram-Area -Garden"

Below is an overhead view of a garden. What is the expression for the area of the garden?

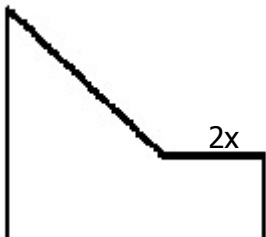

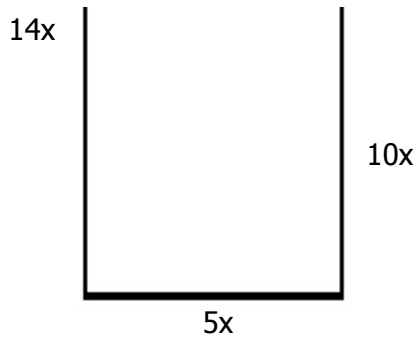

79) Assisment #119493 "119493 - 116398 - Diagram-Area -Garden"

Below is an overhead view of a garden. What is the expression for the area of the garden?

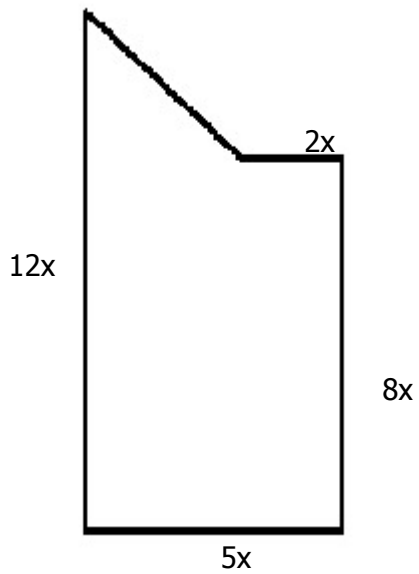

80) Assisment #119494 "119494 - 116398 - Diagram-Area -Garden"

Below is an overhead view of a garden. What is the expression for the area of the garden?

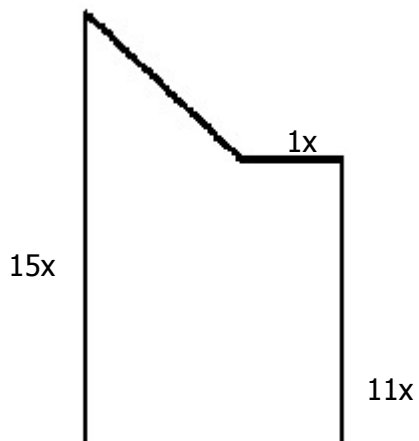

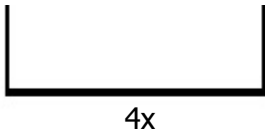

81) Assisment #119515 "119515 - Diagram-Perimeter-Garden"

Below is an overhead view of a garden. If you wanted to put a fence around it, what is the expression for the length of the fence?

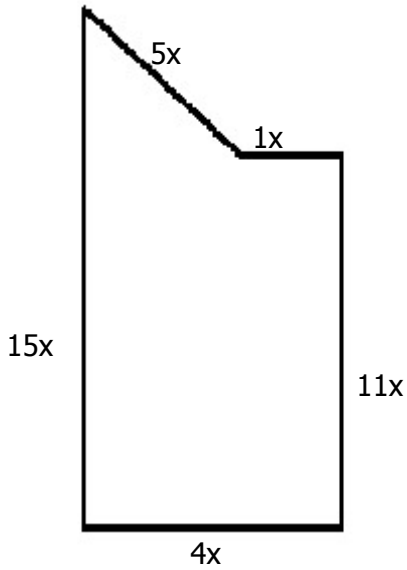

82) Assisment #119516 "119516 - Diagram-Perimeter-Garden"

Below is an overhead view of a garden. If you wanted to put a fence around it, what is the expression for the length of the fence?

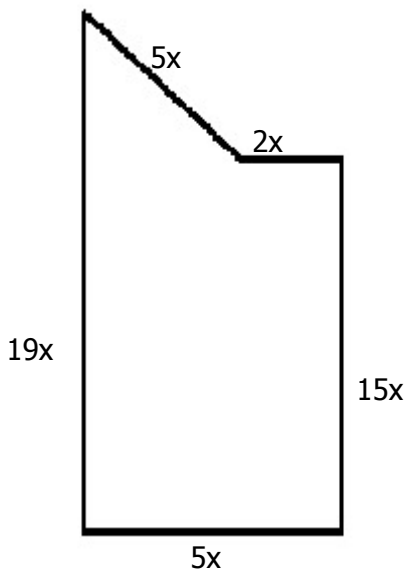

83) Assistent #119517 "119517 - Diagram-Perimeter-Garden"

Below is an overhead view of a garden. If you wanted to put a fence around it, what is the expression for the length of the fence?

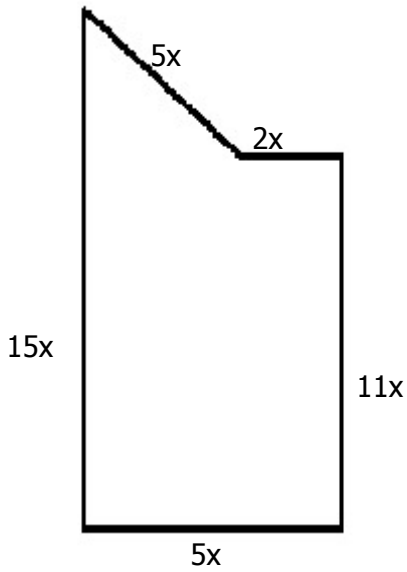

84) Assistent #119518 "119518 - Diagram-Perimeter-Garden"

Below is an overhead view of a garden. If you wanted to put a fence around it, what is the expression for the length of the fence?

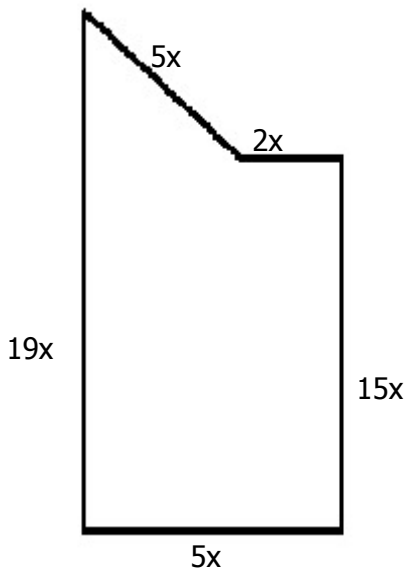

85) Assistent #119519 "119519 - Diagram-Perimeter-Garden"

Below is an overhead view of a garden. If you wanted to put

a fence around it, what is the expression for the length of the fence?

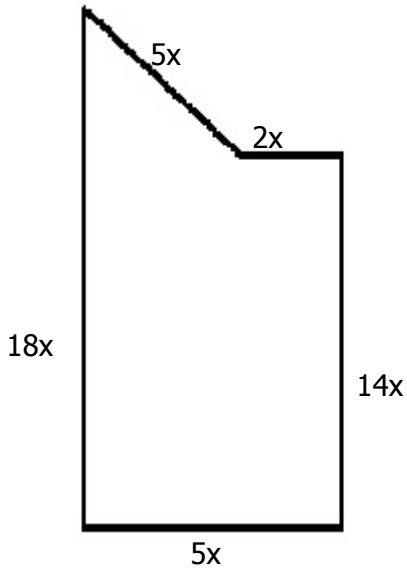

86) Assistent #119520 "119520 - Diagram-Perimeter-Garden"

Below is an overhead view of a garden. If you wanted to put a fence around it, what is the expression for the length of the fence?

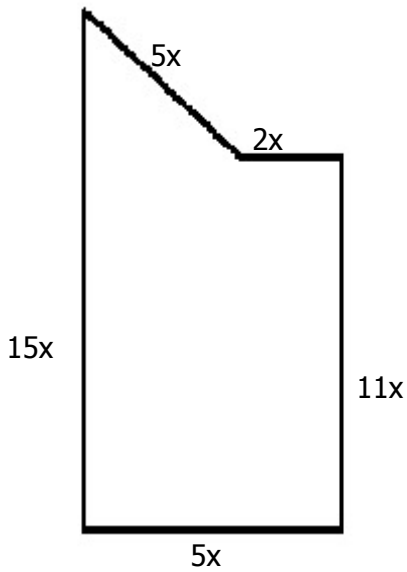

87) Assistent #119521 "119521 - Diagram-Perimeter-Garden"

Below is an overhead view of a garden. If you wanted to put a fence around it, what is the expression for the length of the fence?



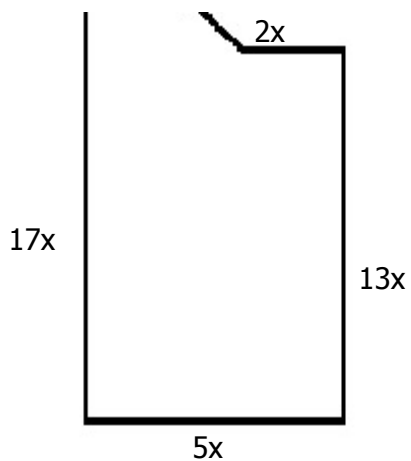

88) Assistent #119522 "119522 - Diagram-Perimeter-Garden"

Below is an overhead view of a garden. If you wanted to put a fence around it, what is the expression for the length of the fence?

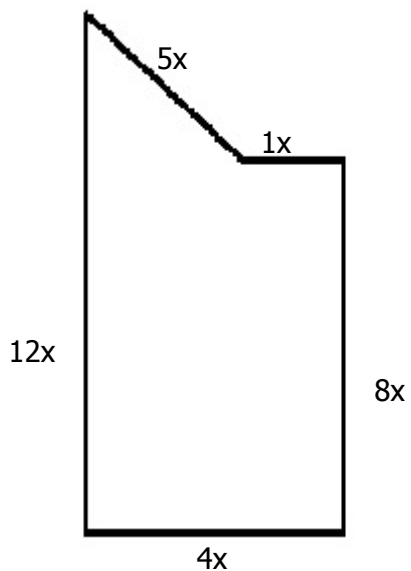

89) Assistent #119523 "119523 - Diagram-Perimeter-Garden"

Below is an overhead view of a garden. If you wanted to put a fence around it, what is the expression for the length of the fence?

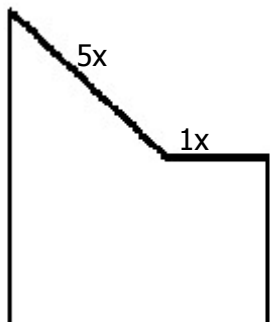

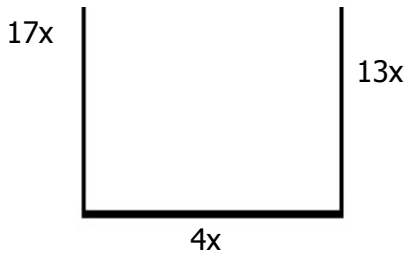

90) Assisment #119524 "119524 - Diagram-Perimeter-Garden"

Below is an overhead view of a garden. If you wanted to put a fence around it, what is the expression for the length of the fence?

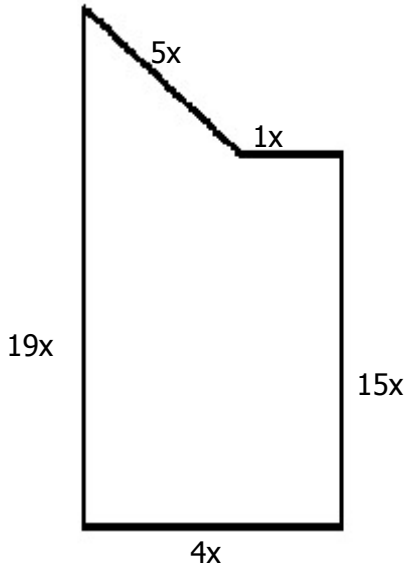

91) Assisment #119525 "119525 - Diagram-Perimeter-Garden"

Below is an overhead view of a garden. If you wanted to put a fence around it, what is the expression for the length of the fence?

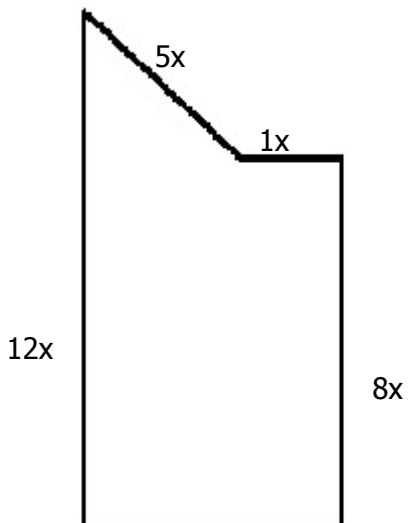

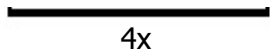

92) Assistent #119526 "119526 - Diagram-Perimeter-Garden"

Below is an overhead view of a garden. If you wanted to put a fence around it, what is the expression for the length of the fence?

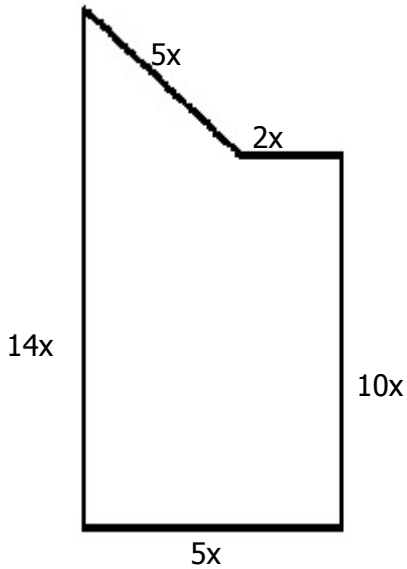

93) Assistent #119527 "119527 - Diagram-Perimeter-Garden"

Below is an overhead view of a garden. If you wanted to put a fence around it, what is the expression for the length of the fence?

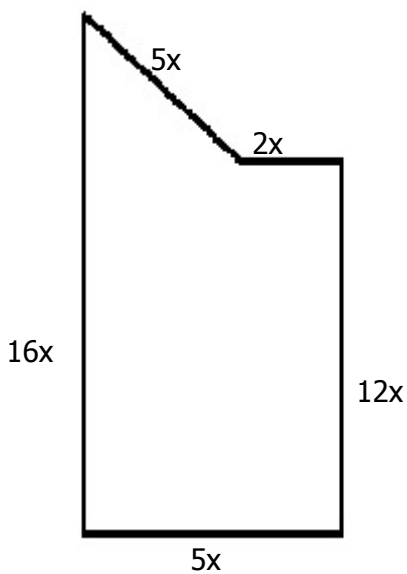

94) Assistent #119528 "119528 - Diagram-Perimeter-Garden"

Below is an overhead view of a garden. If you wanted to put a fence around it, what is the expression for the length of the fence?

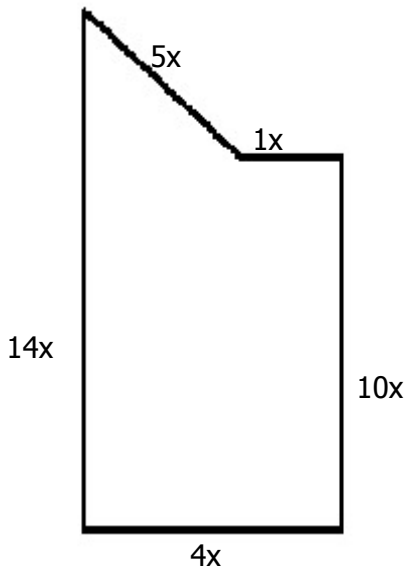

95) Assistent #119529 "119529 - Diagram-Perimeter-Garden"

Below is an overhead view of a garden. If you wanted to put a fence around it, what is the expression for the length of the fence?

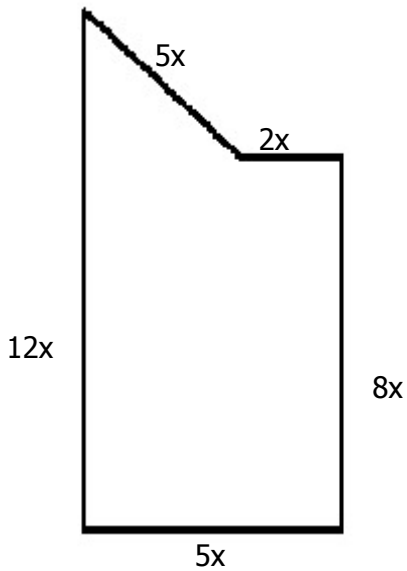

96) Assistent #119530 "119530 - Diagram-Perimeter-Garden"

Below is an overhead view of a garden. If you wanted to put a fence around it, what is the expression for the length of the fence?



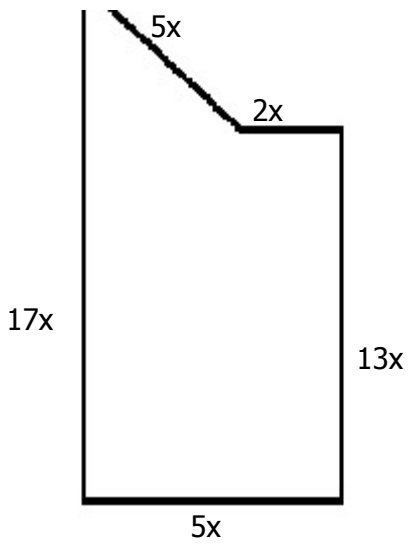

97) Assistent #119531 "119531 - Diagram-Perimeter-Garden"

Below is an overhead view of a garden. If you wanted to put a fence around it, what is the expression for the length of the fence?

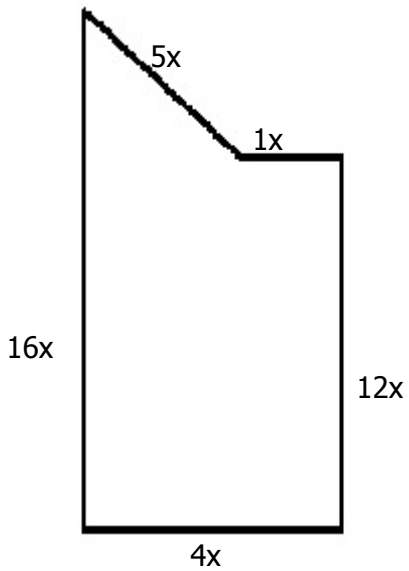

98) Assistent #119532 "119532 - Diagram-Perimeter-Garden"

Below is an overhead view of a garden. If you wanted to put a fence around it, what is the expression for the length of the fence?

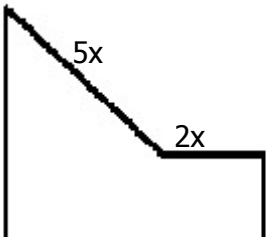

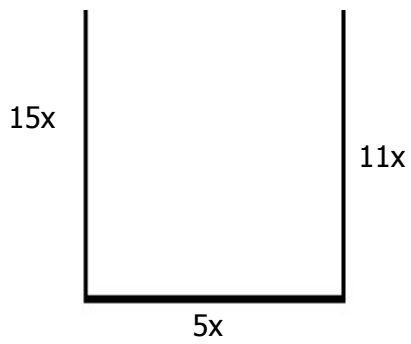

99) Assistentment #119533 "119533 - Diagram-Perimeter-Garden"

Below is an overhead view of a garden. If you wanted to put a fence around it, what is the expression for the length of the fence?

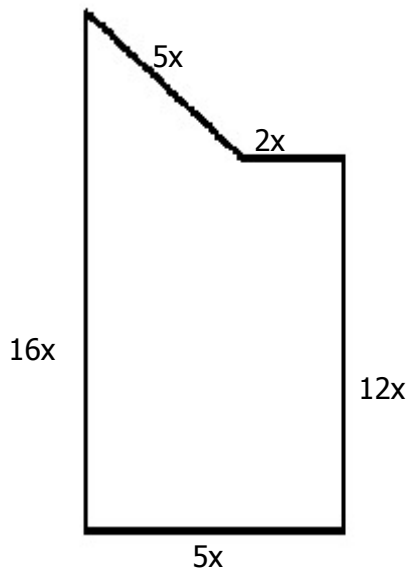

100) Assistentment #119534 "119534 - Diagram-Perimeter-Garden"

Below is an overhead view of a garden. If you wanted to put a fence around it, what is the expression for the length of the fence?

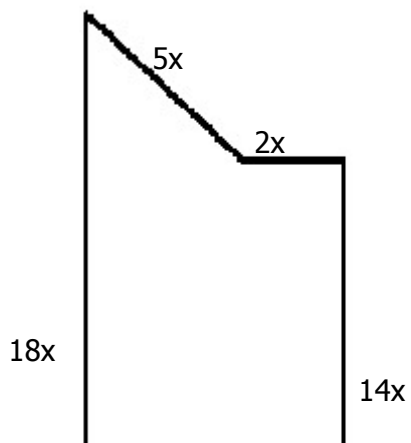

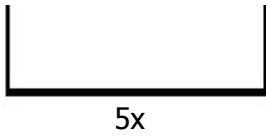

101) Assistent #120522 "120522 - 114045 - Diagram-Area -Can Label"

If the diameter of the can is $2x$, find the expression for the surface area of the label around the can.

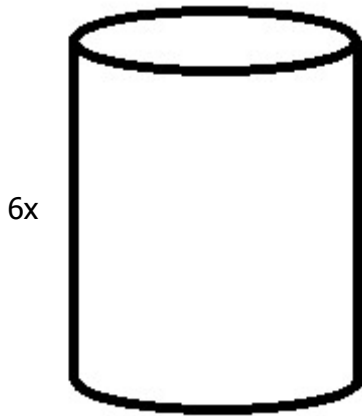

Type π in as "pi" and put any fractions in parantheses.
Ex. $4x^2+(9/5)x^2\pi+6x$

102) Assistent #120523 "120523 - 114045 - Diagram-Area -Can Label"

If the diameter of the can is $1x$, find the expression for the surface area of the label around the can.

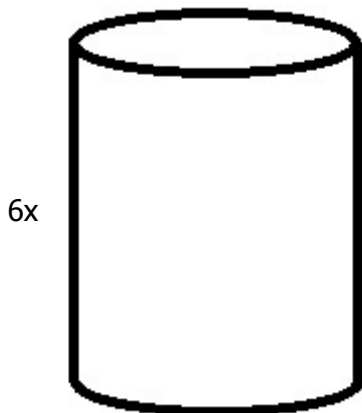

Type π in as "pi" and put any fractions in parantheses.
Ex. $4x^2+(9/5)x^2\pi+6x$

103) Assistent #120524 "120524 - 114045 - Diagram-Area -Can Label"

If the diameter of the can is $4x$, find the expression for the surface area of the label around the can.

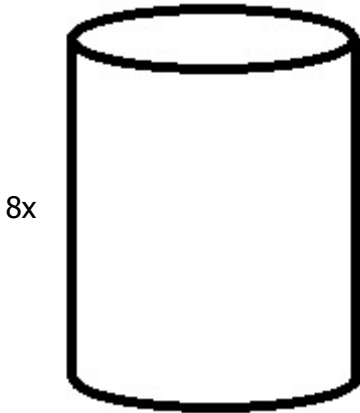

Type π in as "pi" and put any fractions in parantheses.
Ex. $4x^2+(9/5)x^2\pi+6x$

104) Assistent #120525 "120525 - 114045 - Diagram-Area -Can Label"

If the diameter of the can is $1x$, find the expression for the surface area of the label around the can.

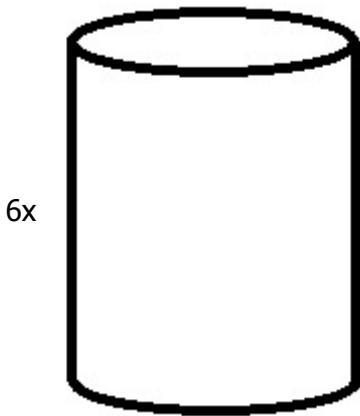

Type π in as "pi" and put any fractions in parantheses.
Ex. $4x^2+(9/5)x^2\pi+6x$

105) Assistent #120526 "120526 - 114045 - Diagram-Area -Can Label"

If the diameter of the can is $4x$, find the expression for the surface area of the label around the can.



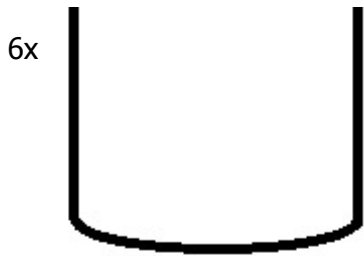

Type π in as "pi" and put any fractions in parentheses.
Ex. $4x^2+(9/5)x^2\pi+6x$

106) Assistent #120527 "120527 - 114045 - Diagram-Area -Can Label"

If the diameter of the can is $3x$, find the expression for the surface area of the label around the can.

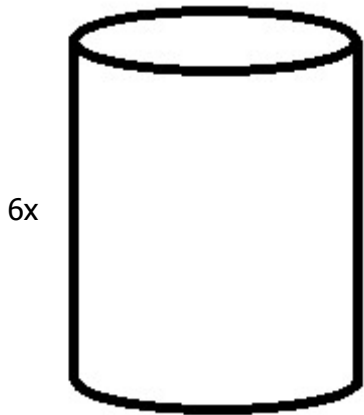

Type π in as "pi" and put any fractions in parentheses.
Ex. $4x^2+(9/5)x^2\pi+6x$

107) Assistent #120528 "120528 - 114045 - Diagram-Area -Can Label"

If the diameter of the can is $2x$, find the expression for the surface area of the label around the can.

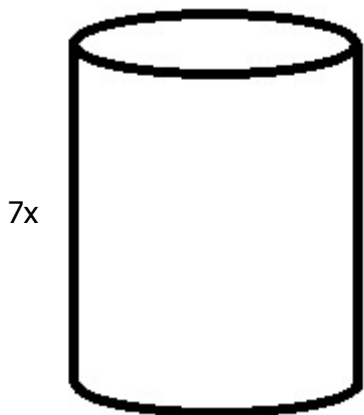

Type π in as "pi" and put any fractions in parentheses.
Ex. $4x^2+(9/5)x^2\pi+6x$

108) Assistent #120529 "120529 - 114045 - Diagram-Area -Can Label"

If the diameter of the can is $4x$, find the expression for the surface area of the label around the can.

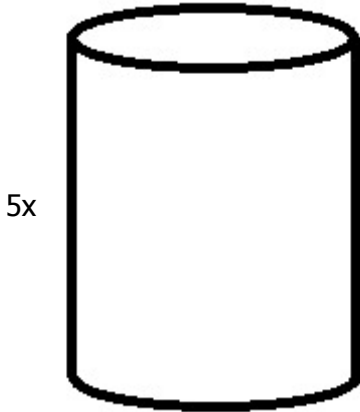

Type π in as "pi" and put any fractions in parentheses.
Ex. $4x^2+(9/5)x^2\pi+6x$

109) Assistent #120530 "120530 - 114045 - Diagram-Area -Can Label"

If the diameter of the can is $2x$, find the expression for the surface area of the label around the can.

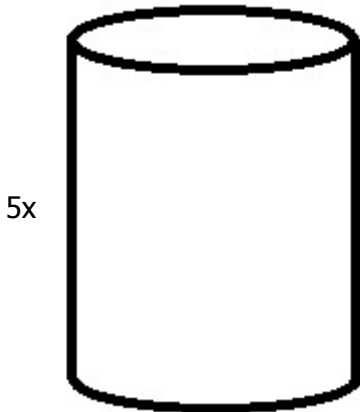

Type π in as "pi" and put any fractions in parentheses.
Ex. $4x^2+(9/5)x^2\pi+6x$

110) Assistent #120531 "120531 - 114045 - Diagram-Area -Can Label"

If the diameter of the can is $4x$, find the expression for the surface area of the label around the can.

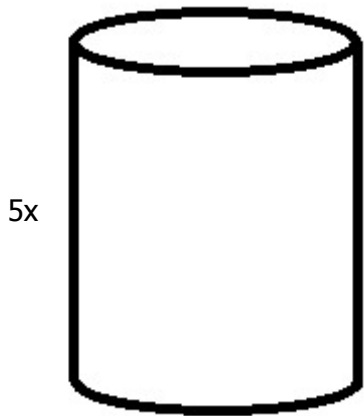

Type π in as "pi" and put any fractions in parentheses.
Ex. $4x^2 + (9/5)x^2\pi + 6x$

111) Assistent #120532 "120532 - 114045 - Diagram-Area -Can Label"

If the diameter of the can is $3x$, find the expression for the surface area of the label around the can.

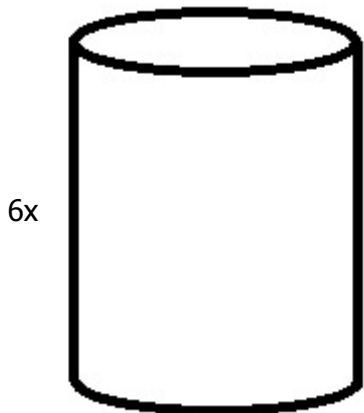

Type π in as "pi" and put any fractions in parentheses.
Ex. $4x^2 + (9/5)x^2\pi + 6x$

112) Assistent #120533 "120533 - 114045 - Diagram-Area -Can Label"

If the diameter of the can is $4x$, find the expression for the surface area of the label around the can.





Type π in as "pi" and put any fractions in parentheses.
Ex. $4x^2 + (9/5)x^2\pi + 6x$

113) Assistent #120534 "120534 - 114045 - Diagram-Area -Can Label"

If the diameter of the can is $4x$, find the expression for the surface area of the label around the can.

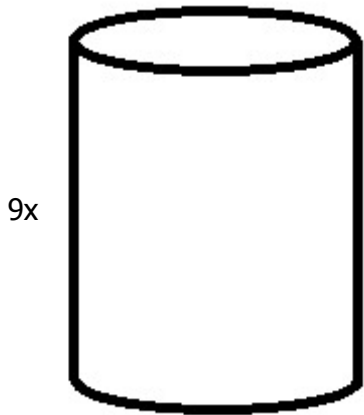

Type π in as "pi" and put any fractions in parentheses.
Ex. $4x^2 + (9/5)x^2\pi + 6x$

114) Assistent #120535 "120535 - 114045 - Diagram-Area -Can Label"

If the diameter of the can is $3x$, find the expression for the surface area of the label around the can.

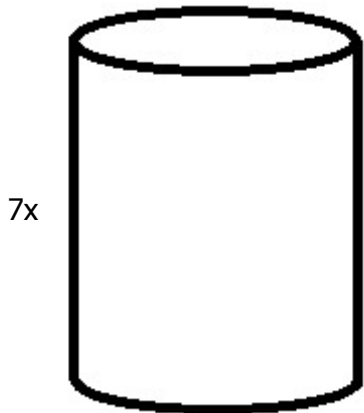

Type π in as "pi" and put any fractions in parentheses.
Ex. $4x^2+(9/5)x^2\pi+6x$

115) Assistent #120536 "120536 - 114045 - Diagram-Area -Can Label"

If the diameter of the can is $4x$, find the expression for the surface area of the label around the can.

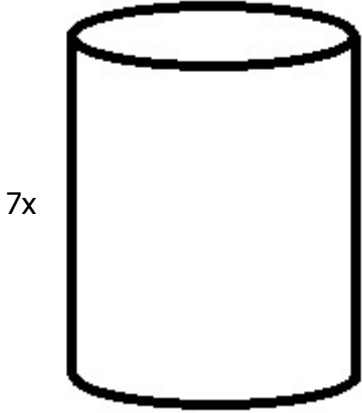

Type π in as "pi" and put any fractions in parentheses.
Ex. $4x^2+(9/5)x^2\pi+6x$

116) Assistent #120537 "120537 - 114045 - Diagram-Area -Can Label"

If the diameter of the can is $3x$, find the expression for the surface area of the label around the can.

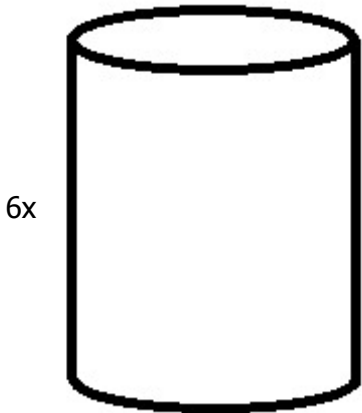

Type π in as "pi" and put any fractions in parentheses.
Ex. $4x^2+(9/5)x^2\pi+6x$

117) Assistent #120538 "120538 - 114045 - Diagram-Area -Can Label"

If the diameter of the can is $2x$, find the expression for the

surface area of the label around the can.

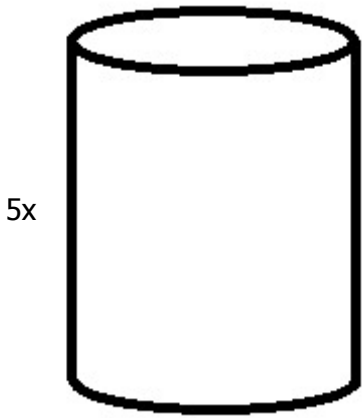

Type π in as "pi" and put any fractions in parentheses.
Ex. $4x^2+(9/5)x^2\pi+6x$

118) Assistent #120539 "120539 - 114045 - Diagram-Area -Can Label"

If the diameter of the can is $4x$, find the expression for the surface area of the label around the can.

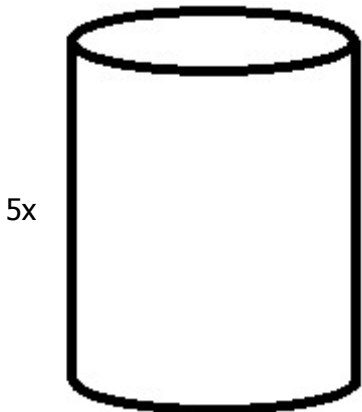

Type π in as "pi" and put any fractions in parentheses.
Ex. $4x^2+(9/5)x^2\pi+6x$

119) Assistent #120540 "120540 - 114045 - Diagram-Area -Can Label"

If the diameter of the can is $2x$, find the expression for the surface area of the label around the can.

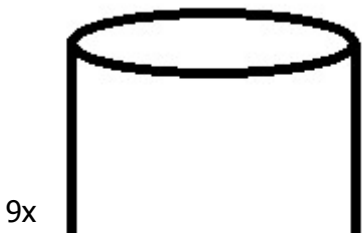



Type π in as "pi" and put any fractions in parentheses.
Ex. $4x^2 + (9/5)x^2\pi + 6x$

120) Assistentment #120541 "120541 - 114045 - Diagram-Area -Can Label"

If the diameter of the can is $4x$, find the expression for the surface area of the label around the can.

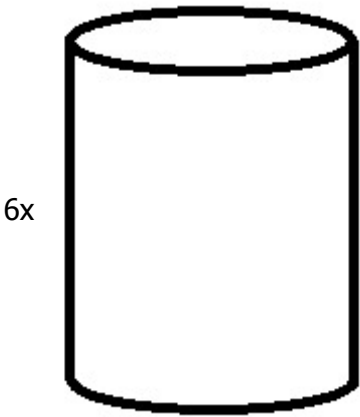

Type π in as "pi" and put any fractions in parentheses.
Ex. $4x^2 + (9/5)x^2\pi + 6x$

1) Assistentment #121191 "121191 - 109059 - %v{q} starts a job..."

Randy starts a job at McDonald's. Randy gets dropped off by his parents at the start of his shift but he takes a taxi home that costs him 5 dollars. Randy gets paid **d dollars** for one night of work. After taking into account his taxi ride, write an expression for how much he makes in one night.

2) Assistentment #121193 "121193 - 109059 - %v{q} starts a job..."

Randy starts a job at McDonald's. Randy gets dropped off by his parents at the start of his shift but he takes a taxi home that costs him 8 dollars. Randy gets paid **d dollars** for one night of work. After taking into account his taxi ride, write an expression for how much he makes in one night.

3) Assistentment #121194 "121194 - 109059 - %v{q} starts a job..."

Samantha starts a job at McDonald's. Samantha gets dropped off by her parents at the start of her shift but she takes a taxi home that costs her 14 dollars. Samantha gets paid **d dollars** for one night of work. After taking into account her taxi ride, write an expression for how much she makes in one night.

4) Assistentment #121195 "121195 - 109059 - %v{q} starts a job..."

Randy starts a job at McDonald's. Randy gets dropped off by his parents at the start of his shift but he takes a taxi home that costs him 10 dollars. Randy gets paid **d dollars** for one night of work. After taking into account his taxi ride, write an expression for how much he makes in one night.

5) Assistentment #121196 "121196 - 109059 - %v{q} starts a job..."

Samantha starts a job at McDonald's. Samantha gets dropped off by her parents at the start of her shift but she takes a taxi home that costs her 12 dollars. Samantha gets paid **d dollars** for one night of work. After taking into account her taxi ride, write an expression for how much she makes in one night.

6) Assistentment #121197 "121197 - 109059 - %v{q} starts a job..."

Randy starts a job at McDonald's. Randy gets dropped off by his parents at the start of his shift but he takes a taxi home that costs him 7 dollars. Randy gets paid **d dollars** for one

night of work. After taking into account his taxi ride, write an expression for how much he makes in one night.

7) Assistent #121199 "121199 - 109059 - %v{q} starts a job..."

Michelle starts a job at McDonald's. Michelle gets dropped off by her parents at the start of her shift but she takes a taxi home that costs her 13 dollars. Michelle gets paid **d dollars** for one night of work. After taking into account her taxi ride, write an expression for how much she makes in one night.

8) Assistent #121200 "121200 - 109059 - %v{q} starts a job..."

Michelle starts a job at McDonald's. Michelle gets dropped off by her parents at the start of her shift but she takes a taxi home that costs her 15 dollars. Michelle gets paid **d dollars** for one night of work. After taking into account her taxi ride, write an expression for how much she makes in one night.

9) Assistent #121201 "121201 - 109059 - %v{q} starts a job..."

Todd starts a job at McDonald's. Todd gets dropped off by his parents at the start of his shift but he takes a taxi home that costs him 6 dollars. Todd gets paid **d dollars** for one night of work. After taking into account his taxi ride, write an expression for how much he makes in one night.

10) Assistent #121206 "121206 - Kylie starts a jo..."

Kylie starts a job at McDonald's that will pay her 13 dollars an hour. Kylie gets dropped off by her parents at the start of the shift but she takes a taxi home that costs her 12 dollars. Kylie works an h hour shift. After taking into account her taxi ride, write an expression for how much she makes in one night.

11) Assistent #121207 "121207 - Mike starts a job..."

Mike starts a job at McDonald's that will pay him 14 dollars an hour. Mike gets dropped off by his parents at the start of the shift but he takes a taxi home that costs him 13 dollars. Mike works an h hour shift. After taking into account his taxi ride, write an expression for how much he makes in one night.

12) Assistent #121208 "121208 - Randy starts a jo..."

Randy starts a job at McDonald's that will pay him 8 dollars an hour. Randy gets dropped off by his parents at the start of the shift but he takes a taxi home that costs him 5 dollars. Randy works an h hour shift. After taking into account his taxi ride, write an expression for how much he makes in one night.

13) Assistent #121209 "121209 - Mike starts a job..."

Mike starts a job at McDonald's that will pay him 6 dollars an hour. Mike gets dropped off by

his parents at the start of the shift but he takes a taxi home that costs him 6 dollars. Mike works an h hour shift. After taking into account his taxi ride, write an expression for how much he makes in one night.

14) Assisment #121210 "121210 - Samantha starts a..."

Samantha starts a job at McDonald's that will pay her 9 dollars an hour. Samantha gets dropped off by her parents at the start of the shift but she takes a taxi home that costs her 6 dollars. Samantha works an h hour shift. After taking into account her taxi ride, write an expression for how much she makes in one night.

15) Assisment #121211 "121211 - Randy starts a jo..."

Randy starts a job at McDonald's that will pay him 10 dollars an hour. Randy gets dropped off by his parents at the start of the shift but he takes a taxi home that costs him 15 dollars. Randy works an h hour shift. After taking into account his taxi ride, write an expression for how much he makes in one night.

16) Assisment #121213 "121213 - Kylie starts a jo..."

Kylie starts a job at McDonald's that will pay her 12 dollars an hour. Kylie gets dropped off by her parents at the start of the shift but she takes a taxi home that costs her 8 dollars. Kylie works an h hour shift. After taking into account her taxi ride, write an expression for how much she makes in one night.

17) Assisment #121214 "121214 - Michelle starts a..."

Michelle starts a job at McDonald's that will pay her 7 dollars an hour. Michelle gets dropped off by her parents at the start of the shift but she takes a taxi home that costs her 11 dollars. Michelle works an h hour shift. After taking into account her taxi ride, write an expression for how much she makes in one night.

18) Assisment #121215 "121215 - Samantha starts a..."

Samantha starts a job at McDonald's that will pay her 15 dollars an hour. Samantha gets dropped off by her parents at the start of the shift but she takes a taxi home that costs her 10 dollars. Samantha works an h hour shift. After taking into account her taxi ride, write an expression for how much she makes in one night.

19) Assisment #121216 "121216 - Michelle starts a..."

Michelle starts a job at McDonald's that will pay her 11 dollars an hour. Michelle gets dropped off by her parents at the start of the shift but she takes a taxi home that costs her 7 dollars. Michelle works an h hour shift. After taking into account her taxi ride, write an expression for how much she makes in one night.

20) Assisment #121217 "121217 - Randy starts a jo..."

Randy starts a job at McDonald's that will pay him 11 dollars an hour. Randy gets dropped off by his parents at the start of the shift but he takes a taxi home that costs him 13 dollars. Randy works an h hour shift. After taking into account his taxi ride, write an expression for how much he makes in one night.

21) Assistent #121218 "121218 - Mike starts a job..."

Mike starts a job at McDonald's that will pay him 8 dollars an hour. Mike gets dropped off by his parents at the start of the shift but he takes a taxi home that costs him 9 dollars. Mike works an h hour shift. After taking into account his taxi ride, write an expression for how much he makes in one night.

22) Assistent #121219 "121219 - Todd starts a job..."

Todd starts a job at McDonald's that will pay him 14 dollars an hour. Todd gets dropped off by his parents at the start of the shift but he takes a taxi home that costs him 14 dollars. Todd works an h hour shift. After taking into account his taxi ride, write an expression for how much he makes in one night.

23) Assistent #121220 "121220 - Samantha starts a..."

Samantha starts a job at McDonald's that will pay her 7 dollars an hour. Samantha gets dropped off by her parents at the start of the shift but she takes a taxi home that costs her 7 dollars. Samantha works an h hour shift. After taking into account her taxi ride, write an expression for how much she makes in one night.

24) Assistent #121221 "121221 - 109308 - %v{p} is in a row b..."

Hatfield is in a row boat on a lake. He is 859 yards from the dock. He then rows for m minutes back toward the dock. Hatfield rows at a speed of 52 yards per minute. Write an expression for Hatfield's distance from the dock dependent on the number of minutes he has rowed.

25) Assistent #121222 "121222 - 109308 - %v{p} is in a row b..."

Ann is in a row boat on a lake. She is 795 yards from the dock. She then rows for m minutes back toward the dock. Ann rows at a speed of 39 yards per minute. Write an expression for Ann's distance from the dock dependent on the number of minutes she has rowed.

26) Assistent #121223 "121223 - 109308 - %v{p} is in a row b..."

Anthony is in a row boat on a lake. He is 753 yards from the dock. He then rows for m minutes back toward the dock. Anthony rows at a speed of 58 yards per minute. Write an expression for Anthony's distance from the dock dependent on the number of minutes he has rowed.

27) Assistent #121224 "121224 - 109308 - %v{p} is in a row b..."

Liz is in a row boat on a lake. She is 796 yards from the dock. She then rows for m minutes back toward the dock. Liz rows at a speed of 34 yards per minute. Write an expression for Liz's distance from the dock dependent on the number of minutes she has rowed.

28) Assistent #121225 "121225 - 109308 - $\%v\{p\}$ is in a row b..."

Eric is in a row boat on a lake. He is 882 yards from the dock. He then rows for m minutes back toward the dock. Eric rows at a speed of 34 yards per minute. Write an expression for Eric's distance from the dock dependent on the number of minutes he has rowed.

29) Assistent #121226 "121226 - 109308 - $\%v\{p\}$ is in a row b..."

Hatfield is in a row boat on a lake. He is 629 yards from the dock. He then rows for m minutes back toward the dock. Hatfield rows at a speed of 39 yards per minute. Write an expression for Hatfield's distance from the dock dependent on the number of minutes he has rowed.

30) Assistent #121227 "121227 - 109308 - $\%v\{p\}$ is in a row b..."

Ann is in a row boat on a lake. She is 832 yards from the dock. She then rows for m minutes back toward the dock. Ann rows at a speed of 32 yards per minute. Write an expression for Ann's distance from the dock dependent on the number of minutes she has rowed.

31) Assistent #121228 "121228 - 109308 - $\%v\{p\}$ is in a row b..."

Hatfield is in a row boat on a lake. He is 648 yards from the dock. He then rows for m minutes back toward the dock. Hatfield rows at a speed of 33 yards per minute. Write an expression for Hatfield's distance from the dock dependent on the number of minutes he has rowed.

32) Assistent #121229 "121229 - 109308 - $\%v\{p\}$ is in a row b..."

Eric is in a row boat on a lake. He is 886 yards from the dock. He then rows for m minutes back toward the dock. Eric rows at a speed of 32 yards per minute. Write an expression for Eric's distance from the dock dependent on the number of minutes he has rowed.

33) Assistent #121230 "121230 - 109308 - $\%v\{p\}$ is in a row b..."

Eric is in a row boat on a lake. He is 682 yards from the dock. He then rows for m minutes back toward the dock. Eric rows at a speed of 57 yards per minute. Write an expression for Eric's distance from the dock dependent on the number of minutes he has rowed.

34) Assistent #121231 "121231 - 109308 - $\%v\{p\}$ is in a row b..."

Ann is in a row boat on a lake. She is 734 yards from the dock. She then rows for m minutes back toward the dock. Ann rows at a speed of 53 yards per minute. Write an expression for Ann's distance from the dock dependent on the number of minutes she has

rowed.

35) Assisment #121232 "121232 - 109308 - %v{p} is in a row b..."

Eric is in a row boat on a lake. He is 677 yards from the dock. He then rows for m minutes back toward the dock. Eric rows at a speed of 52 yards per minute. Write an expression for Eric's distance from the dock dependent on the number of minutes he has rowed.

36) Assisment #121233 "121233 - 109308 - %v{p} is in a row b..."

Pauline is in a row boat on a lake. She is 895 yards from the dock. She then rows for m minutes back toward the dock. Pauline rows at a speed of 51 yards per minute. Write an expression for Pauline's distance from the dock dependent on the number of minutes she has rowed.

37) Assisment #121234 "121234 - 109308 - %v{p} is in a row b..."

Hatfield is in a row boat on a lake. He is 814 yards from the dock. He then rows for m minutes back toward the dock. Hatfield rows at a speed of 58 yards per minute. Write an expression for Hatfield's distance from the dock dependent on the number of minutes he has rowed.

38) Assisment #121235 "121235 - 109308 - %v{p} is in a row b..."

Eric is in a row boat on a lake. He is 823 yards from the dock. He then rows for m minutes back toward the dock. Eric rows at a speed of 30 yards per minute. Write an expression for Eric's distance from the dock dependent on the number of minutes he has rowed.

39) Assisment #121251 "121251 - John and his..."

John and his wife Beth have been saving to give their 5 children presents for the holidays. John has saved 995 dollars for presents and Beth has saved **b dollars**. Write an expression for how much they have saved together.

40) Assisment #121252 "121252 - John and his..."

John and his wife Beth have been saving to give their 5 children presents for the holidays. John has saved 1144 dollars for presents and Beth has saved **b dollars**. Write an expression for how much they have saved together.

41) Assisment #121253 "121253 - Larry and h..."

Larry and his wife Ann have been saving to give their 5 children presents for the holidays. Larry has saved 717 dollars for presents and Ann has saved **b dollars**. Write an expression for how much they have saved together.

43) Assisment #121255 "121255 - Steve and h..."

Steve and his wife Caroll have been saving to give their 5 children presents for the holidays. Steve has saved 876 dollars for presents and Caroll has saved **b dollars**. Write an expression for how much they have saved together.

44) Assisment #121256 "121256 - Larry and h..."

Larry and his wife Ann have been saving to give their 5 children presents for the holidays. Larry has saved 801 dollars for presents and Ann has saved **b dollars**. Write an expression for how much they have saved together.

45) Assisment #121257 "121257 - Steve and h..."

Steve and his wife Caroll have been saving to give their 5 children presents for the holidays. Steve has saved 771 dollars for presents and Caroll has saved **b dollars**. Write an expression for how much they have saved together.

46) Assisment #121258 "121258 - Steve and h..."

Steve and his wife Caroll have been saving to give their 5 children presents for the holidays. Steve has saved 701 dollars for presents and Caroll has saved **b dollars**. Write an expression for how much they have saved together.

47) Assisment #121259 "121259 - Larry and h..."

Larry and his wife Ann have been saving to give their 5 children presents for the holidays. Larry has saved 772 dollars for presents and Ann has saved **b dollars**. Write an expression for how much they have saved together.

48) Assisment #121260 "121260 - Steve and h..."

Steve and his wife Caroll have been saving to give their 5 children presents for the holidays. Steve has saved 1043 dollars for presents and Caroll has saved **b dollars**. Write an expression for how much they have saved together.

49) Assisment #121261 "121261 - Steve and h..."

Steve and his wife Caroll have been saving to give their 5 children presents for the holidays. Steve has saved 1062 dollars for presents and Caroll has saved **b dollars**. Write an expression for how much they have saved together.

51) Assistent #121263 "121263 - John and his..."

John and his wife Beth have been saving to give their 5 children presents for the holidays. John has saved 854 dollars for presents and Beth has saved **b dollars**. Write an expression for how much they have saved together.

52) Assistent #121264 "121264 - Larry and h..."

Larry and his wife Ann have been saving to give their 5 children presents for the holidays. Larry has saved 1176 dollars for presents and Ann has saved **b dollars**. Write an expression for how much they have saved together.

53) Assistent #121265 "121265 - John and his..."

John and his wife Beth have been saving to give their 5 children presents for the holidays. John has saved 953 dollars for presents and Beth has saved **b dollars**. Write an expression for how much they have saved together.

54) Assistent #121266 "121266 - Jerome made&..."

Jerome made 76 dollars by washing cars to buy holiday presents. He decided to spend m dollars on a present for his mom and then use the remainder to buy presents for each of his 4 sisters. He will spend the same amount on each sister. Write an expression for how much he can spend on each sister.

55) Assistent #121267 "121267 - Jerome made&..."

Jerome made 82 dollars by washing cars to buy holiday presents. He decided to spend m dollars on a present for his mom and then use the remainder to buy presents for each of his 4 sisters. He will spend the same amount on each sister. Write an expression for how much he can spend on each sister.

56) Assistent #121268 "121268 - Claire made&..."

Claire made 136 dollars by washing cars to buy holiday presents. She decided to spend m dollars on a present for her mom and then use the remainder to buy presents for each of her 4 sisters. She will spend the same amount on each sister. Write an expression for how much she can spend on each sister.

57) Assistent #121269 "121269 - Douglas made..."

Douglas made 117 dollars by washing cars to buy holiday presents. He decided to spend m dollars on a present for his mom and then use the remainder to buy presents for each

much he can spend on each sister.

58) Assistent #121270 "121270 - Jason made&n..."

Jason made 145 dollars by washing cars to buy holiday presents. He decided to spend m dollars on a present for his mom and then use the remainder to buy presents for each of his 6 sisters. He will spend the same amount on each sister. Write an expression for how much he can spend on each sister.

59) Assistent #121271 "121271 - Gretchen mad..."

Gretchen made 104 dollars by washing cars to buy holiday presents. She decided to spend m dollars on a present for her mom and then use the remainder to buy presents for each of her 6 sisters. She will spend the same amount on each sister. Write an expression for how much she can spend on each sister.

60) Assistent #121272 "121272 - Sandy made&n..."

Sandy made 91 dollars by washing cars to buy holiday presents. She decided to spend m dollars on a present for her mom and then use the remainder to buy presents for each of her 5 sisters. She will spend the same amount on each sister. Write an expression for how much she can spend on each sister.

61) Assistent #121273 "121273 - Sandy made&n..."

Sandy made 114 dollars by washing cars to buy holiday presents. She decided to spend m dollars on a present for her mom and then use the remainder to buy presents for each of her 5 sisters. She will spend the same amount on each sister. Write an expression for how much she can spend on each sister.

62) Assistent #121274 "121274 - Douglas made..."

Douglas made 123 dollars by washing cars to buy holiday presents. He decided to spend m dollars on a present for his mom and then use the remainder to buy presents for each of his 5 sisters. He will spend the same amount on each sister. Write an expression for how much he can spend on each sister.

63) Assistent #121275 "121275 - Jerome made&n..."

Jerome made 128 dollars by washing cars to buy holiday presents. He decided to spend m dollars on a present for his mom and then use the remainder to buy presents for each of his 4 sisters. He will spend the same amount on each sister. Write an expression for how much he can spend on each sister.

64) Assistent #121276 "121276 - Claire made&n..."

Claire made 95 dollars by washing cars to buy holiday presents. She decided to spend m

dollars on a present for her mom and then use the remainder to buy presents for each of her 4 sisters. She will spend the same amount on each sister. Write an expression for how much she can spend on each sister.

65) Assistent #121277 "121277 - Jason made&n..."

Jason made 81 dollars by washing cars to buy holiday presents. He decided to spend m dollars on a present for his mom and then use the remainder to buy presents for each of his 6 sisters. He will spend the same amount on each sister. Write an expression for how much he can spend on each sister.

66) Assistent #121278 "121278 - Claire made&..."

Claire made 120 dollars by washing cars to buy holiday presents. She decided to spend m dollars on a present for her mom and then use the remainder to buy presents for each of her 4 sisters. She will spend the same amount on each sister. Write an expression for how much she can spend on each sister.

67) Assistent #121279 "121279 - Claire made&..."

Claire made 75 dollars by washing cars to buy holiday presents. She decided to spend m dollars on a present for her mom and then use the remainder to buy presents for each of her 4 sisters. She will spend the same amount on each sister. Write an expression for how much she can spend on each sister.

68) Assistent #121280 "121280 - Jerome made&..."

Jerome made 117 dollars by washing cars to buy holiday presents. He decided to spend m dollars on a present for his mom and then use the remainder to buy presents for each of his 4 sisters. He will spend the same amount on each sister. Write an expression for how much he can spend on each sister.

69) Assistent #121281 "121281 - Matt drove ..."

Matt drove 559 miles from Boston to Pittsburgh to visit his grandmother. The trip took him t hours. What was his average driving speed (in miles per hour)?

70) Assistent #121282 "121282 - Linnea drove..."

Linnea drove 525 miles from Boston to Pittsburgh to visit her grandmother. The trip took her t hours. What was her average driving speed (in miles per hour)?

71) Assistent #121283 "121283 - Kelsey drove..."

Kelsey drove 513 miles from Boston to Pittsburgh to visit her grandmother. The trip took her t hours. What was her average driving speed (in miles per hour)?

72) Assisment #121284 "121284 - Matt drove ..."

Matt drove 503 miles from Boston to Pittsburgh to visit his grandmother. The trip took him t hours. What was his average driving speed (in miles per hour)?

73) Assisment #121285 "121285 - Jimmy drove..."

Jimmy drove 556 miles from Boston to Pittsburgh to visit his grandmother. The trip took him t hours. What was his average driving speed (in miles per hour)?

74) Assisment #121286 "121286 - Linnea drove..."

Linnea drove 578 miles from Boston to Pittsburgh to visit her grandmother. The trip took her t hours. What was her average driving speed (in miles per hour)?

75) Assisment #121287 "121287 - Linnea drove..."

Linnea drove 507 miles from Boston to Pittsburgh to visit her grandmother. The trip took her t hours. What was her average driving speed (in miles per hour)?

76) Assisment #121288 "121288 - Petra drove ..."

Petra drove 511 miles from Boston to Pittsburgh to visit her grandmother. The trip took her t hours. What was her average driving speed (in miles per hour)?

77) Assisment #121289 "121289 - Linnea drove..."

Linnea drove 566 miles from Boston to Pittsburgh to visit her grandmother. The trip took her t hours. What was her average driving speed (in miles per hour)?

78) Assisment #121290 "121290 - Petra drove ..."

Petra drove 532 miles from Boston to Pittsburgh to visit her grandmother. The trip took her t hours. What was her average driving speed (in miles per hour)?

79) Assisment #121293 "121293 - Matt drove ..."

Matt drove 562 miles from Boston to Pittsburgh to visit his grandmother. The trip took him t hours. What was his average driving speed (in miles per hour)?

80) Assisment #121294 "121294 - Kelsey drove..."

Kelsey drove 533 miles from Boston to Pittsburgh to visit her grandmother. The trip took her t hours. What was her average driving speed (in miles per hour)?

81) Assisment #121295 "121295 - Petra drove ..."

Petra drove 528 miles from Boston to Pittsburgh to visit her grandmother. The trip took her t hours. What was her average driving speed (in miles per hour)?

82) Assisment #121296 "121296 - Mary opened ..."

Mary opened a new music store. She got CDs delivered on her first day. She got 2 truck loads of CDs delivered. Each truck that arrived dropped off 8 boxes. Each box she received had c CD's. Write an expression for how many CDs were delivered that first day.

83) Assisment #121297 "121297 - Ivan opened ..."

Ivan opened a new music store. He got CDs delivered on his first day. He got 5 truck loads of CDs delivered. Each truck that arrived dropped off 14 boxes. Each box he received had c CD's. Write an expression for how many CDs were delivered that first day.

84) Assisment #121298 "121298 - Michael open..."

Michael opened a new music store. He got CDs delivered on his first day. He got 9 truck loads of CDs delivered. Each truck that arrived dropped off 7 boxes. Each box he received had c CD's. Write an expression for how many CDs were delivered that first day.

85) Assisment #121299 "121299 - Mary opened ..."

Mary opened a new music store. She got CDs delivered on her first day. She got 8 truck loads of CDs delivered. Each truck that arrived dropped off 10 boxes. Each box she received had c CD's. Write an expression for how many CDs were delivered that first day.

86) Assisment #121300 "121300 - Michael open..."

Michael opened a new music store. He got CDs delivered on his first day. He got 9 truck loads of CDs delivered. Each truck that arrived dropped off 4 boxes. Each box he received had c CD's. Write an expression for how many CDs were delivered that first day.

87) Assisment #121301 "121301 - Mary opened ..."

Mary opened a new music store. She got CDs delivered on her first day. She got 10 truck loads of CDs delivered. Each truck that arrived dropped off 14 boxes. Each box she received had c CD's. Write an expression for how many CDs were delivered that first day.

88) Assisment #121302 "121302 - Yizhou opene..."

Yizhou opened a new music store. He got CDs delivered on his first day.
He got 8 truck loads of CDs delivered. Each truck that arrived dropped off 5 boxes.
Each box he received had c CD's.
Write an expression for how many CDs were delivered that first day.

89) Assistent #121303 "121303 - Irena opened..."

Irena opened a new music store. She got CDs delivered on her first day.
She got 10 truck loads of CDs delivered. Each truck that arrived dropped off 15 boxes.
Each box she received had c CD's.
Write an expression for how many CDs were delivered that first day.

90) Assistent #121304 "121304 - Irena opened..."

Irena opened a new music store. She got CDs delivered on her first day.
She got 6 truck loads of CDs delivered. Each truck that arrived dropped off 11 boxes.
Each box she received had c CD's.
Write an expression for how many CDs were delivered that first day.

91) Assistent #121305 "121305 - Irena opened..."

Irena opened a new music store. She got CDs delivered on her first day.
She got 2 truck loads of CDs delivered. Each truck that arrived dropped off 14 boxes.
Each box she received had c CD's.
Write an expression for how many CDs were delivered that first day.

92) Assistent #121306 "121306 - Ivan opened ..."

Ivan opened a new music store. He got CDs delivered on his first day.
He got 4 truck loads of CDs delivered. Each truck that arrived dropped off 13 boxes.
Each box he received had c CD's.
Write an expression for how many CDs were delivered that first day.

93) Assistent #121307 "121307 - Mary opened ..."

Mary opened a new music store. She got CDs delivered on her first day.
She got 6 truck loads of CDs delivered. Each truck that arrived dropped off 2 boxes.
Each box she received had c CD's.
Write an expression for how many CDs were delivered that first day.

94) Assistent #121309 "121309 - Michael open..."

Michael opened a new music store. He got CDs delivered on his first day.
He got 3 truck loads of CDs delivered. Each truck that arrived dropped off 7 boxes.
Each box he received had c CD's.
Write an expression for how many CDs were delivered that first day.

95) Assistent #121310 "121310 - Yizhou opene..."

Yizhou opened a new music store. He got COs delivered on his first day.
He got 4 truck loads of COs delivered. Each truck that arrived dropped off 15 boxes.
Each box he received had c CO's.
Write an expression for how many COs were delivered that first day.

Problem Set 15456 "Solving Variable Equation testing" id:[15456]

1) Assistent #119109 "119109 - solving variable equation 1a"

Give the value of 'a' in terms of 'b' and 'c' from the following expression:
 $2a+16b = 20c$

So fill in the blank for

a = _____

2) Assistent #119110 "119110 - solving variable equation 1a"

Give the value of 'a' in terms of 'b' and 'c' from the following expression:
 $-2a+16b = 18c$

So fill in the blank for

a = _____

3) Assistent #119111 "119111 - solving variable equation 1a"

Give the value of 'a' in terms of 'b' and 'c' from the following expression:
 $-2a+10b = 22c$

So fill in the blank for

a = _____

4) Assistent #119112 "119112 - solving variable equation 1a"

Give the value of 'a' in terms of 'b' and 'c' from the following expression:
 $-2a+18b = 22c$

So fill in the blank for

a = _____

5) Assistent #119113 "119113 - solving variable equation 1a"

Give the value of 'a' in terms of 'b' and 'c' from the following expression:
 $-2a+16b = 20c$

So fill in the blank for

a = _____

6) Assistent #119114 "119114 - solving variable equation 1a"

Give the value of 'a' in terms of 'b' and 'c' from the following expression:
 $-2a+12b = 8c$

So fill in the blank for

a = _____

7) Assistent #119115 "119115 - solving variable equation 1a"

Give the value of 'a' in terms of 'b' and 'c' from the following expression:
 $2a+18b = 18c$

So fill in the blank for

a = _____

8) Assistent #119116 "119116 - solving variable equation 1a"

Give the value of 'a' in terms of 'b' and 'c' from the following expression:
 $2a+6b = 10c$

So fill in the blank for

a = _____

9) Assistent #119117 "119117 - solving variable equation 1a"

Give the value of 'a' in terms of 'b' and 'c' from the following expression:
 $2a+8b = 6c$

So fill in the blank for

$$a = \underline{\hspace{2cm}}$$

10) Assistentment #119118 "119118 - solving variable equation 1a"

Give the value of 'a' in terms of 'b' and 'c' from the following expression:

$$2a+18b = 4c$$

So fill in the blank for

$$a = \underline{\hspace{2cm}}$$

11) Assistentment #119119 "119119 - 111681 - solving variable equation 2a"

Give the value of 'b' in terms of 'a' and 'c' from the following expression:

$$2(8a+2b) = -30c$$

So fill in the blank for

$$b = \underline{\hspace{2cm}}$$

12) Assistentment #119120 "119120 - 111681 - solving variable equation 2a"

Give the value of 'b' in terms of 'a' and 'c' from the following expression:

$$2(2a+6b) = 10c$$

So fill in the blank for

$$b = \underline{\hspace{2cm}}$$

13) Assistentment #119121 "119121 - 111681 - solving variable equation 2a"

Give the value of 'b' in terms of 'a' and 'c' from the following expression:

$$-2(2a+2b) = 16c$$

So fill in the blank for

$$b = \underline{\hspace{4cm}}$$

14) Assistentment #119122 "119122 - 111681 - solving variable equation 2a"

Give the value of 'b' in terms of 'a' and 'c' from the following expression:

$$-2(4a+4b) = -28c$$

So fill in the blank for

$$b = \underline{\hspace{4cm}}$$

15) Assistentment #119123 "119123 - 111681 - solving variable equation 2a"

Give the value of 'b' in terms of 'a' and 'c' from the following expression:

$$-2(4a+8b) = -22c$$

So fill in the blank for

$$b = \underline{\hspace{4cm}}$$

16) Assistentment #119124 "119124 - 111681 - solving variable equation 2a"

Give the value of 'b' in terms of 'a' and 'c' from the following expression:

$$2(4a+4b) = -30c$$

So fill in the blank for

$$b = \underline{\hspace{4cm}}$$

17) Assistentment #119125 "119125 - 111681 - solving variable equation 2a"

Give the value of 'b' in terms of 'a' and 'c' from the following expression:

$$2(6a+6b) = 2c$$

So fill in the blank for

$$b = \underline{\hspace{2cm}}$$

18) Assistent #119126 "119126 - 111681 - solving variable equation 2a"

Give the value of 'b' in terms of 'a' and 'c' from the following expression:

$$-2(2a+2b) = -2c$$

So fill in the blank for

$$b = \underline{\hspace{2cm}}$$

19) Assistent #119127 "119127 - 111681 - solving variable equation 2a"

Give the value of 'b' in terms of 'a' and 'c' from the following expression:

$$-2(4a+4b) = 32c$$

So fill in the blank for

$$b = \underline{\hspace{2cm}}$$

20) Assistent #119128 "119128 - 111681 - solving variable equation 2a"

Give the value of 'b' in terms of 'a' and 'c' from the following expression:

$$-2(6a+12b) = -10c$$

So fill in the blank for

$$b = \underline{\hspace{2cm}}$$

21) Assistent #119129 "119129 - solving variable equation 2b"

Give the value of 'b' in terms of 'a' and 'c' from the following expression:

$$2(8a-4b) = -14c$$

So fill in the blank for

$$b = \underline{\hspace{2cm}}$$

22) Assistentment #119130 "119130 - solving variable equation 2b"

Give the value of 'b' in terms of 'a' and 'c' from the following expression:

$$2(6a-10b) = 30c$$

So fill in the blank for

$$b = \underline{\hspace{2cm}}$$

23) Assistentment #119131 "119131 - solving variable equation 2b"

Give the value of 'b' in terms of 'a' and 'c' from the following expression:

$$-2(2a-2b) = 20c$$

So fill in the blank for

$$b = \underline{\hspace{2cm}}$$

24) Assistentment #119132 "119132 - solving variable equation 2b"

Give the value of 'b' in terms of 'a' and 'c' from the following expression:

$$-2(6a-8b) = -2c$$

So fill in the blank for

$$b = \underline{\hspace{2cm}}$$

25) Assistentment #119133 "119133 - solving variable equation 2b"

Give the value of 'b' in terms of 'a' and 'c' from the following expression:

$$2(4a-6b) = -6c$$

So fill in the blank for

$$b = \underline{\hspace{2cm}}$$

26) Assistent #119134 "119134 - solving variable equation 2b"

Give the value of 'b' in terms of 'a' and 'c' from the following expression:

$$-2(8a-12b) = 14c$$

So fill in the blank for

$$b = \underline{\hspace{2cm}}$$

27) Assistent #119135 "119135 - solving variable equation 2b"

Give the value of 'b' in terms of 'a' and 'c' from the following expression:

$$2(8a-2b) = -32c$$

So fill in the blank for

$$b = \underline{\hspace{2cm}}$$

28) Assistent #119136 "119136 - solving variable equation 2b"

Give the value of 'b' in terms of 'a' and 'c' from the following expression:

$$2(2a-6b) = -18c$$

So fill in the blank for

$$b = \underline{\hspace{2cm}}$$

29) Assistent #119137 "119137 - solving variable equation 2b"

Give the value of 'b' in terms of 'a' and 'c' from the following expression:

$$2(6a-8b) = -16c$$

So fill in the blank for

30) Assistent #119138 "119138 - solving variable equation 2b"

Give the value of 'b' in terms of 'a' and 'c' from the following expression:

$$-2(4a-8b) = 24c$$

So fill in the blank for

$$b = \underline{\hspace{2cm}}$$

31) Assistent #119139 "119139 - solving variable equation 1b"

Give the value of 'a' in terms of 'b' and 'c' from the following expression:

$$2a-16b = 8c$$

So fill in the blank for

$$a = \underline{\hspace{2cm}}$$

32) Assistent #119140 "119140 - solving variable equation 1b"

Give the value of 'a' in terms of 'b' and 'c' from the following expression:

$$2a-16b = 8c$$

So fill in the blank for

$$a = \underline{\hspace{2cm}}$$

33) Assistent #119141 "119141 - solving variable equation 1b"

Give the value of 'a' in terms of 'b' and 'c' from the following expression:

$$-2a-22b = 20c$$

So fill in the blank for

34) Assistentment #119142 "119142 - solving variable equation 1b"

Give the value of 'a' in terms of 'b' and 'c' from the following expression:

$$2a - 2b = 8c$$

So fill in the blank for

$$a = \underline{\hspace{2cm}}$$

35) Assistentment #119143 "119143 - solving variable equation 1b"

Give the value of 'a' in terms of 'b' and 'c' from the following expression:

$$2a - 20b = 22c$$

So fill in the blank for

$$a = \underline{\hspace{2cm}}$$

36) Assistentment #119144 "119144 - solving variable equation 1b"

Give the value of 'a' in terms of 'b' and 'c' from the following expression:

$$2a - 16b = 14c$$

So fill in the blank for

$$a = \underline{\hspace{2cm}}$$

37) Assistentment #119145 "119145 - solving variable equation 1b"

Give the value of 'a' in terms of 'b' and 'c' from the following expression:

$$2a - 6b = 2c$$

So fill in the blank for

$$a = \underline{\hspace{2cm}}$$

38) Assistentment #119146 "119146 - solving variable equation 1b"

Give the value of 'a' in terms of 'b' and 'c' from the following expression:

$$2a - 6b = 18c$$

So fill in the blank for

$$a = \underline{\hspace{2cm}}$$

39) Assistentment #119147 "119147 - solving variable equation 1b"

Give the value of 'a' in terms of 'b' and 'c' from the following expression:

$$-2a - 20b = 4c$$

So fill in the blank for

$$a = \underline{\hspace{2cm}}$$

40) Assistentment #119148 "119148 - solving variable equation 1b"

Give the value of 'a' in terms of 'b' and 'c' from the following expression:

$$2a - 16b = 14c$$

So fill in the blank for

$$a = \underline{\hspace{2cm}}$$

41) Assistentment #119149 "119149 - 113484 - solving variable equation 4a"

Give the value of 'a' in terms of 'b' from the following expression:

$$2(15a + 5b) = -10$$

So fill in the blank for

$$a = \underline{\hspace{2cm}}$$

42) Assistent #119150 "119150 - 113484 - solving variable equation 4a"

Give the value of 'a' in terms of 'b' from the following expression:

$$-2(10a + 9b) = 10$$

So fill in the blank for

$$a = \underline{\hspace{2cm}}$$

43) Assistent #119151 "119151 - 113484 - solving variable equation 4a"

Give the value of 'a' in terms of 'b' from the following expression:

$$-2(10a + 8b) = 4$$

So fill in the blank for

$$a = \underline{\hspace{2cm}}$$

44) Assistent #119152 "119152 - 113484 - solving variable equation 4a"

Give the value of 'a' in terms of 'b' from the following expression:

$$2(13a + 1b) = -18$$

So fill in the blank for

$$a = \underline{\hspace{2cm}}$$

45) Assistent #119153 "119153 - 113484 - solving variable equation 4a"

Give the value of 'a' in terms of 'b' from the following expression:

$$2(8a + 5b) = -12$$

So fill in the blank for

$$a = \underline{\hspace{2cm}}$$

46) Assistent #119154 "119154 - 113484 - solving variable equation 4a"

Give the value of 'a' in terms of 'b' from the following expression:

$$-2(16a + 12b) = -18$$

So fill in the blank for

$$a = \underline{\hspace{2cm}}$$

47) Assistent #119155 "119155 - 113484 - solving variable equation 4a"

Give the value of 'a' in terms of 'b' from the following expression:

$$-2(15a + 5b) = -20$$

So fill in the blank for

$$a = \underline{\hspace{2cm}}$$

48) Assistent #119156 "119156 - 113484 - solving variable equation 4a"

Give the value of 'a' in terms of 'b' from the following expression:

$$-2(10a + 3b) = 8$$

So fill in the blank for

$$a = \underline{\hspace{2cm}}$$

49) Assistent #119157 "119157 - 113484 - solving variable equation 4a"

Give the value of 'a' in terms of 'b' from the following expression:

$$-2(3a + 12b) = -4$$

So fill in the blank for

$$a = \underline{\hspace{2cm}}$$

50) Assistent #119158 "119158 - 113484 - solving variable equation 4a"

Give the value of 'a' in terms of 'b' from the following expression:

$$2(4a + 12b) = -14$$

So fill in the blank for

a = _____

51) Assistent #119159 "119159 - solving variable equation 4b"

Give the value of 'a' in terms of 'b' from the following expression:

$$2(7a - 15b) = -8$$

So fill in the blank for

a = _____

52) Assistent #119160 "119160 - solving variable equation 4b"

Give the value of 'a' in terms of 'b' from the following expression:

$$2(11a - 7b) = 16$$

So fill in the blank for

a = _____

53) Assistent #119161 "119161 - solving variable equation 4b"

Give the value of 'a' in terms of 'b' from the following expression:

$$-2(11a - 8b) = -10$$

So fill in the blank for

a = _____

54) Assistent #119162 "119162 - solving variable equation 4b"

Give the value of 'a' in terms of 'b' from the following expression:

$$-2(6a - 3b) = 20$$

So fill in the blank for

a = _____

55) Assistent #119163 "119163 - solving variable equation 4b"

Give the value of 'a' in terms of 'b' from the following expression:

$$-2(15a - 12b) = 8$$

So fill in the blank for

a = _____

56) Assistent #119164 "119164 - solving variable equation 4b"

Give the value of 'a' in terms of 'b' from the following expression:

$$-2(3a - 9b) = -4$$

So fill in the blank for

a = _____

57) Assistent #119165 "119165 - solving variable equation 4b"

Give the value of 'a' in terms of 'b' from the following expression:

$$2(5a - 13b) = -14$$

So fill in the blank for

a = _____

58) Assistent #119166 "119166 - solving variable equation 4b"

Give the value of 'a' in terms of 'b' from the following expression:

$$2(6a - 13b) = -2$$

So fill in the blank for

a = _____

59) Assistent #119167 "119167 - solving variable equation 4b"

Give the value of 'a' in terms of 'b' from the following expression:

$$2(6a - 5b) = -12$$

So fill in the blank for

a = _____

60) Assistent #119168 "119168 - solving variable equation 4b"

Give the value of 'a' in terms of 'b' from the following expression:

$$2(8a - 13b) = -2$$

So fill in the blank for

a = _____

61) Assistent #119169 "119169 - solving variable equation 5a"

Give the value of 'a' from the following expression:

$$(8a + 11) + (11a + 11) = -3$$

So fill in the blank for

a = _____

62) Assistent #119170 "119170 - solving variable equation 5a"

Give the value of 'a' from the following expression:

$$(16a + 11) + (8a + 3) = 8$$

So fill in the blank for

a = _____

63) Assistent #119171 "119171 - solving variable equation 5a"

Give the value of 'a' from the following expression:

$$(12a + 5) + (11a + 10) = -4$$

So fill in the blank for

a = _____

64) Assistent #119172 "119172 - solving variable equation 5a"

Give the value of 'a' from the following expression:

$$(11a + 8) + (3a + 1) = -9$$

So fill in the blank for

a = _____

65) Assistent #119173 "119173 - solving variable equation 5a"

Give the value of 'a' from the following expression:

$$(16a + 6) + (1a + 1) = -10$$

So fill in the blank for

$$a = \underline{\hspace{2cm}}$$

66) Assisment #119174 "119174 - solving variable equation 5a"

Give the value of 'a' from the following expression:

$$(3a + 8) + (12a + 6) = 2$$

So fill in the blank for

$$a = \underline{\hspace{2cm}}$$

67) Assisment #119175 "119175 - solving variable equation 5a"

Give the value of 'a' from the following expression:

$$(5a + 3) + (7a + 6) = -3$$

So fill in the blank for

$$a = \underline{\hspace{2cm}}$$

68) Assisment #119176 "119176 - solving variable equation 5a"

Give the value of 'a' from the following expression:

$$(9a + 7) + (2a + 7) = 4$$

So fill in the blank for

$$a = \underline{\hspace{2cm}}$$

69) Assisment #119177 "119177 - solving variable equation 5a"

Give the value of 'a' from the following expression:

$$(5a + 11) + (3a + 9) = 6$$

So fill in the blank for

a = _____

70) Assistent #119178 "119178 - solving variable equation 5a"

Give the value of 'a' from the following expression:

$$(11a + 3) + (5a + 7) = 2$$

So fill in the blank for

a = _____

71) Assistent #119179 "119179 - solving variable equation 5b"

Give the value of 'a' from the following expression:

$$(14a + 3) - (3a + 14) = -3$$

So fill in the blank for

a = _____

72) Assistent #119180 "119180 - solving variable equation 5b"

Give the value of 'a' from the following expression:

$$(17a + 4) - (4a + 9) = -10$$

So fill in the blank for

a = _____

73) Assistent #119181 "119181 - solving variable equation 5b"

Give the value of 'a' from the following expression:

$$(10a + 5) - (4a + 6) = 10$$

So fill in the blank for

$$a = \underline{\hspace{2cm}}$$

74) Assistent #119182 "119182 - solving variable equation 5b"

Give the value of 'a' from the following expression:

$$(17a + 2) - (1a + 6) = -6$$

So fill in the blank for

$$a = \underline{\hspace{2cm}}$$

75) Assistent #119183 "119183 - solving variable equation 5b"

Give the value of 'a' from the following expression:

$$(12a + 3) - (4a + 8) = 8$$

So fill in the blank for

$$a = \underline{\hspace{2cm}}$$

76) Assistent #119184 "119184 - solving variable equation 5b"

Give the value of 'a' from the following expression:

$$(15a + 3) - (3a + 7) = -7$$

So fill in the blank for

$$a = \underline{\hspace{2cm}}$$

77) Assistent #119185 "119185 - solving variable equation 5b"

Give the value of 'a' from the following expression:

$$(10a + 2) - (4a + 16) = 6$$

So fill in the blank for

$$a = \underline{\hspace{2cm}}$$

78) Assistentment #119186 "119186 - solving variable equation 5b"

Give the value of 'a' from the following expression:

$$(15a + 3) - (4a + 12) = 10$$

So fill in the blank for

a = _____

79) Assistentment #119187 "119187 - solving variable equation 5b"

Give the value of 'a' from the following expression:

$$(21a + 5) - (5a + 14) = -2$$

So fill in the blank for

a = _____

80) Assistentment #119188 "119188 - solving variable equation 5b"

Give the value of 'a' from the following expression:

$$(11a + 1) - (3a + 12) = -5$$

So fill in the blank for

a = _____

Problem Set 6915 "Solving for an unknown using scale factor" id:[6915]

1) Assistent #48300 "48300 - Solving for an Unknown in a Proportion"

Find the value of **a** that makes the fraction equivalent.

$$\frac{\mathbf{a}}{25} = \frac{15}{5}$$

2) Assistent #48301 "48301 - Solving for an Unknown in a Proportion"

Find the value of **y** that makes the fraction equivalent.

$$\frac{\mathbf{y}}{18} = \frac{17}{3}$$

3) Assistent #48302 "48302 - Solving for an Unknown in a Proportion"

Find the value of **a** that makes the fraction equivalent.

$$\frac{\mathbf{a}}{36} = \frac{14}{9}$$

4) Assistent #48303 "48303 - Solving for an Unknown in a Proportion"

Find the value of **d** that makes the fraction equivalent.

$$\frac{d}{54} = \frac{11}{9}$$

-
- 5) Assistent #48304 "48304 - Solving for an Unknown in a Proportion"
Find the value of **c** that makes the fraction equivalent.

$$\frac{c}{35} = \frac{14}{7}$$

-
- 6) Assistent #48305 "48305 - Solving for an Unknown in a Proportion"
Find the value of **b** that makes the fraction equivalent.

$$\frac{b}{20} = \frac{12}{4}$$

-
- 7) Assistent #48306 "48306 - Solving for an Unknown in a Proportion"
Find the value of **b** that makes the fraction equivalent.

$$\frac{b}{15} = \frac{15}{3}$$

-
- 8) Assistent #48307 "48307 - Solving for an Unknown in a Proportion"
Find the value of **d** that makes the fraction equivalent.

$$\frac{d}{12} = \frac{14}{4}$$

9) Assistent #48308 "48308 - Solving for an Unknown in a Proportion"

Find the value of **c** that makes the fraction equivalent.

$$\frac{c}{54} = \frac{12}{9}$$

10) Assistent #48309 "48309 - Solving for an Unknown in a Proportion"

Find the value of **y** that makes the fraction equivalent.

$$\frac{y}{36} = \frac{13}{9}$$

11) Assistent #48310 "48310 - Solving for an Unknown in a Proportion"

Find the value of **y** that makes the fraction equivalent.

$$\frac{y}{32} = \frac{18}{8}$$

12) Assistent #48312 "48312 - Solving for an Unknown in a Proportion"

Find the value of **c** that makes the fraction equivalent.

$$\frac{c}{20} = \frac{15}{4}$$

13) Assistent #48313 "48313 - Solving for an Unknown in a Proportion"

Find the value of **a** that makes the fraction equivalent.

$$\frac{a}{36} = \frac{15}{6}$$

14) Assistent #48314 "48314 - Solving for an Unknown in a Proportion"

Find the value of **c** that makes the fraction equivalent.

$$\frac{c}{9} = \frac{18}{3}$$

15) Assistent #48315 "48315 - Solving for an Unknown in a Proportion"

Find the value of **a** that makes the fraction equivalent.

$$\frac{a}{9} = \frac{15}{3}$$

16) Assistent #48316 "48316 - Solving for an Unknown in a Proportion"

Find the value of **b** that makes the fraction equivalent.

$$\frac{b}{\quad} = \frac{10}{\quad}$$

17) Assistent #48317 "48317 - Solving for an Unknown in a Proportion"

Find the value of **b** that makes the fraction equivalent.

$$\frac{\mathbf{b}}{\mathbf{36}} = \frac{\mathbf{16}}{\mathbf{9}}$$

18) Assistent #48318 "48318 - Solving for an Unknown in a Proportion"

Find the value of **c** that makes the fraction equivalent.

$$\frac{\mathbf{c}}{\mathbf{28}} = \frac{\mathbf{11}}{\mathbf{7}}$$

19) Assistent #48319 "48319 - Solving for an Unknown in a Proportion"

Find the value of **c** that makes the fraction equivalent.

$$\frac{\mathbf{c}}{\mathbf{12}} = \frac{\mathbf{12}}{\mathbf{4}}$$

20) Assistent #48320 "48320 - Solving for an Unknown in a Proportion"

Find the value of **b** that makes the fraction equivalent.

$$\frac{\mathbf{b}}{\mathbf{25}} = \frac{\mathbf{16}}{\mathbf{5}}$$

21) Assistent #48321 "48321 - Solving for an Unknown in a Proportion"

Find the value of **y** that makes the fraction equivalent.

$$\frac{y}{36} = \frac{16}{6}$$

22) Assistent #48322 "48322 - Solving for an Unknown in a Proportion"

Find the value of **b** that makes the fraction equivalent.

$$\frac{b}{12} = \frac{17}{4}$$

23) Assistent #48323 "48323 - Solving for an Unknown in a Proportion"

Find the value of **a** that makes the fraction equivalent.

$$\frac{a}{24} = \frac{12}{8}$$

24) Assistent #48324 "48324 - Solving for an Unknown in a Proportion"

Find the value of **a** that makes the fraction equivalent.

$$\frac{a}{16} = \frac{13}{4}$$

25) Assistent #48325 "48325 - Solving for an Unknown in a Proportion"

Find the value of **d** that makes the fraction equivalent.

$$\frac{d}{54} = \frac{12}{9}$$

26) Assistent #48326 "48326 - Solving for an Unknown in a Proportion"

Find the value of **a** that makes the fraction equivalent.

$$\frac{a}{15} = \frac{11}{3}$$

27) Assistent #48327 "48327 - Solving for an Unknown in a Proportion"

Find the value of **a** that makes the fraction equivalent.

$$\frac{a}{9} = \frac{15}{3}$$

28) Assistent #48328 "48328 - Solving for an Unknown in a Proportion"

Find the value of **d** that makes the fraction equivalent.

$$\frac{d}{20} = \frac{11}{4}$$

29) Assistent #48329 "48329 - Solving for an Unknown in a Proportion"

Find the value of **y** that makes the fraction equivalent.

$$\frac{y}{21} = \frac{15}{7}$$

30) Assistent #48330 "48330 - Solving for an Unknown in a Proportion"

Find the value of **y** that makes the fraction equivalent.

$$\frac{y}{32} = \frac{12}{8}$$

31) Assistent #48331 "48331 - Solving for an Unknown in a Proportion"

Find the value of **c** that makes the fraction equivalent.

$$\frac{c}{24} = \frac{12}{6}$$

32) Assistent #48332 "48332 - Solving for an Unknown in a Proportion"

Find the value of **d** that makes the fraction equivalent.

$$\frac{d}{25} = \frac{12}{5}$$

33) Assistent #48333 "48333 - Solving for an Unknown in a Proportion"

Find the value of **d** that makes the fraction equivalent.

$$\frac{d}{32} = \frac{18}{8}$$

34) Assistent #48334 "48334 - Solving for an Unknown in a Proportion"

Find the value of **c** that makes the fraction equivalent.

$$\frac{c}{15} = \frac{10}{3}$$

35) Assistent #48335 "48335 - Solving for an Unknown in a Proportion"

Find the value of **b** that makes the fraction equivalent.

$$\frac{b}{9} = \frac{15}{3}$$

36) Assistent #48336 "48336 - Solving for an Unknown in a Proportion"

Find the value of **d** that makes the fraction equivalent.

$$\frac{d}{35} = \frac{14}{7}$$

37) Assistent #48337 "48337 - Solving for an Unknown in a Proportion"

Find the value of **d** that makes the fraction equivalent.

$$\frac{d}{35} = \frac{18}{7}$$

38) Assistent #48338 "48338 - Solving for an Unknown in a Proportion"
Find the value of **c** that makes the fraction equivalent.

$$\frac{c}{54} = \frac{14}{9}$$

39) Assistent #48339 "48339 - Solving for an Unknown in a Proportion"
Find the value of **c** that makes the fraction equivalent.

$$\frac{c}{12} = \frac{12}{4}$$

40) Assistent #48340 "48340 - Solving for an Unknown in a Proportion"
Find the value of **b** that makes the fraction equivalent.

$$\frac{b}{12} = \frac{18}{4}$$

41) Assistent #48341 "48341 - Solving for an Unknown in a Proportion"
Find the value of **d** that makes the fraction equivalent.

$$\frac{d}{32} = \frac{10}{8}$$

42) Assistent #48342 "48342 - Solving for an Unknown in a Proportion"

Find the value of **c** that makes the fraction equivalent.

$$\frac{c}{27} = \frac{11}{9}$$

43) Assistent #48343 "48343 - Solving for an Unknown in a Proportion"

Find the value of **c** that makes the fraction equivalent.

$$\frac{c}{24} = \frac{15}{6}$$

44) Assistent #48344 "48344 - Solving for an Unknown in a Proportion"

Find the value of **y** that makes the fraction equivalent.

$$\frac{y}{18} = \frac{15}{3}$$

45) Assistent #48345 "48345 - Solving for an Unknown in a Proportion"

Find the value of **c** that makes the fraction equivalent.

$$\frac{c}{27} = \frac{14}{9}$$

46) Assistent #48346 "48346 - Solving for an Unknown in a Proportion"

Find the value of **a** that makes the fraction equivalent.

$$\frac{a}{12} = \frac{18}{3}$$

47) Assistent #48347 "48347 - Solving for an Unknown in a Proportion"

Find the value of **c** that makes the fraction equivalent.

$$\frac{c}{25} = \frac{17}{5}$$

48) Assistent #48348 "48348 - Solving for an Unknown in a Proportion"

Find the value of **c** that makes the fraction equivalent.

$$\frac{c}{36} = \frac{12}{9}$$

49) Assistent #48349 "48349 - Solving for an Unknown in a Proportion"

Find the value of **y** that makes the fraction equivalent.

$$\frac{y}{\quad} = \frac{14}{\quad}$$

50) Assistent #48350 "48350 - Solving for an Unknown in a Proportion"

Find the value of **b** that makes the fraction equivalent.

$$\frac{\mathbf{b}}{20} = \frac{10}{4}$$

51) Assistent #48351 "48351 - Solving for an Unknown in a Proportion"

Find the value of **d** that makes the fraction equivalent.

$$\frac{\mathbf{d}}{30} = \frac{15}{5}$$

52) Assistent #48352 "48352 - Solving for an Unknown in a Proportion"

Find the value of **c** that makes the fraction equivalent.

$$\frac{\mathbf{c}}{12} = \frac{12}{3}$$

53) Assistent #48353 "48353 - Solving for an Unknown in a Proportion"

Find the value of **a** that makes the fraction equivalent.

$$\frac{\mathbf{a}}{30} = \frac{11}{5}$$

54) Assistent #48354 "48354 - Solving for an Unknown in a Proportion"

Find the value of **d** that makes the fraction equivalent.

$$\frac{d}{18} = \frac{16}{3}$$

55) Assistent #48355 "48355 - Solving for an Unknown in a Proportion"

Find the value of **y** that makes the fraction equivalent.

$$\frac{y}{42} = \frac{13}{7}$$

56) Assistent #48356 "48356 - Solving for an Unknown in a Proportion"

Find the value of **b** that makes the fraction equivalent.

$$\frac{b}{54} = \frac{11}{9}$$

57) Assistent #48357 "48357 - Solving for an Unknown in a Proportion"

Find the value of **d** that makes the fraction equivalent.

$$\frac{d}{36} = \frac{14}{9}$$

58) Assistent #48358 "48358 - Solving for an Unknown in a Proportion"

Find the value of **d** that makes the fraction equivalent.

$$\frac{d}{12} = \frac{11}{4}$$

59) Assistent #48359 "48359 - Solving for an Unknown in a Proportion"

Find the value of **y** that makes the fraction equivalent.

$$\frac{y}{42} = \frac{17}{7}$$

60) Assistent #48360 "48360 - Solving for an Unknown in a Proportion"

Find the value of **b** that makes the fraction equivalent.

$$\frac{b}{27} = \frac{16}{9}$$

61) Assistent #48361 "48361 - Solving for an Unknown in a Proportion"

Find the value of **b** that makes the fraction equivalent.

$$\frac{b}{15} = \frac{13}{5}$$

62) Assistent #48362 "48362 - Solving for an Unknown in a Proportion"

Find the value of **y** that makes the fraction equivalent.

$$\frac{y}{35} = \frac{12}{7}$$

63) Assistent #48363 "48363 - Solving for an Unknown in a Proportion"

Find the value of **d** that makes the fraction equivalent.

$$\frac{d}{48} = \frac{10}{8}$$

64) Assistent #48364 "48364 - Solving for an Unknown in a Proportion"

Find the value of **y** that makes the fraction equivalent.

$$\frac{y}{30} = \frac{13}{5}$$

65) Assistent #48365 "48365 - Solving for an Unknown in a Proportion"

Find the value of **y** that makes the fraction equivalent.

$$\frac{y}{21} = \frac{13}{7}$$

66) Assistent #48366 "48366 - Solving for an Unknown in a Proportion"

Find the value of **d** that makes the fraction equivalent.

$$\frac{d}{18} = \frac{14}{3}$$

67) Assistent #48367 "48367 - Solving for an Unknown in a Proportion"

Find the value of **c** that makes the fraction equivalent.

$$\frac{c}{20} = \frac{11}{4}$$

68) Assistent #48368 "48368 - Solving for an Unknown in a Proportion"

Find the value of **y** that makes the fraction equivalent.

$$\frac{y}{25} = \frac{15}{5}$$

69) Assistent #48369 "48369 - Solving for an Unknown in a Proportion"

Find the value of **y** that makes the fraction equivalent.

$$\frac{y}{54} = \frac{17}{9}$$

70) Assistent #48370 "48370 - Solving for an Unknown in a Proportion"

Find the value of **y** that makes the fraction equivalent.

$$\frac{y}{45} = \frac{17}{9}$$

71) Assistent #48371 "48371 - Solving for an Unknown in a Proportion"

Find the value of **y** that makes the fraction equivalent.

$$\frac{y}{36} = \frac{18}{6}$$

72) Assistent #48372 "48372 - Solving for an Unknown in a Proportion"

Find the value of **a** that makes the fraction equivalent.

$$\frac{a}{54} = \frac{11}{9}$$

73) Assistent #48373 "48373 - Solving for an Unknown in a Proportion"

Find the value of **d** that makes the fraction equivalent.

$$\frac{d}{27} = \frac{10}{9}$$

74) Assistent #48374 "48374 - Solving for an Unknown in a Proportion"

Find the value of **c** that makes the fraction equivalent.

$$\frac{c}{40} = \frac{11}{8}$$

75) Assistent #48375 "48375 - Solving for an Unknown in a Proportion"

Find the value of **d** that makes the fraction equivalent.

$$\frac{d}{32} = \frac{14}{8}$$

76) Assistent #48376 "48376 - Solving for an Unknown in a Proportion"

Find the value of **c** that makes the fraction equivalent.

$$\frac{c}{24} = \frac{18}{4}$$

77) Assistent #48377 "48377 - Solving for an Unknown in a Proportion"

Find the value of **c** that makes the fraction equivalent.

$$\frac{c}{12} = \frac{12}{4}$$

78) Assistent #48378 "48378 - Solving for an Unknown in a Proportion"

Find the value of **a** that makes the fraction equivalent.

$$\frac{a}{32} = \frac{10}{8}$$

79) Assistent #48379 "48379 - Solving for an Unknown in a Proportion"

Find the value of **a** that makes the fraction equivalent.

$$\frac{a}{20} = \frac{15}{5}$$

80) Assistent #48380 "48380 - Solving for an Unknown in a Proportion"

Find the value of **b** that makes the fraction equivalent.

$$\frac{b}{21} = \frac{17}{7}$$

81) Assistent #48381 "48381 - Solving for an Unknown in a Proportion"

Find the value of **a** that makes the fraction equivalent.

$$\frac{a}{40} = \frac{13}{8}$$

82) Assistent #48382 "48382 - Solving for an Unknown in a Proportion"

Find the value of **c** that makes the fraction equivalent.

$$\frac{c}{\quad} = \frac{11}{\quad}$$

83) Assistent #48383 "48383 - Solving for an Unknown in a Proportion"

Find the value of **d** that makes the fraction equivalent.

$$\frac{d}{18} = \frac{10}{6}$$

84) Assistent #48384 "48384 - Solving for an Unknown in a Proportion"

Find the value of **a** that makes the fraction equivalent.

$$\frac{a}{15} = \frac{15}{3}$$

85) Assistent #48385 "48385 - Solving for an Unknown in a Proportion"

Find the value of **a** that makes the fraction equivalent.

$$\frac{a}{30} = \frac{16}{5}$$

86) Assistent #48386 "48386 - Solving for an Unknown in a Proportion"

Find the value of **a** that makes the fraction equivalent.

$$\frac{a}{18} = \frac{12}{6}$$

87) Assistent #48387 "48387 - Solving for an Unknown in a Proportion"

Find the value of **d** that makes the fraction equivalent.

$$\frac{d}{36} = \frac{16}{6}$$

88) Assistent #48388 "48388 - Solving for an Unknown in a Proportion"

Find the value of **y** that makes the fraction equivalent.

$$\frac{y}{36} = \frac{13}{6}$$

89) Assistent #48389 "48389 - Solving for an Unknown in a Proportion"

Find the value of **b** that makes the fraction equivalent.

$$\frac{b}{36} = \frac{13}{9}$$

90) Assistent #48390 "48390 - Solving for an Unknown in a Proportion"

Find the value of **a** that makes the fraction equivalent.

$$\frac{a}{24} = \frac{18}{6}$$

91) Assistent #48391 "48391 - Solving for an Unknown in a Proportion"

Find the value of **b** that makes the fraction equivalent.

$$\frac{\mathbf{b}}{\mathbf{28}} = \frac{\mathbf{11}}{\mathbf{7}}$$

92) Assistent #48392 "48392 - Solving for an Unknown in a Proportion"

Find the value of **b** that makes the fraction equivalent.

$$\frac{\mathbf{b}}{\mathbf{30}} = \frac{\mathbf{18}}{\mathbf{5}}$$

93) Assistent #48393 "48393 - Solving for an Unknown in a Proportion"

Find the value of **a** that makes the fraction equivalent.

$$\frac{\mathbf{a}}{\mathbf{36}} = \frac{\mathbf{11}}{\mathbf{6}}$$

94) Assistent #48394 "48394 - Solving for an Unknown in a Proportion"

Find the value of **a** that makes the fraction equivalent.

$$\frac{\mathbf{a}}{\mathbf{20}} = \frac{\mathbf{11}}{\mathbf{4}}$$

95) Assistent #48395 "48395 - Solving for an Unknown in a Proportion"

Find the value of **y** that makes the fraction equivalent.

$$\frac{y}{12} = \frac{12}{3}$$

96) Assistent #48396 "48396 - Solving for an Unknown in a Proportion"

Find the value of **d** that makes the fraction equivalent.

$$\frac{d}{54} = \frac{10}{9}$$

97) Assistent #48397 "48397 - Solving for an Unknown in a Proportion"

Find the value of **c** that makes the fraction equivalent.

$$\frac{c}{20} = \frac{12}{4}$$

98) Assistent #48398 "48398 - Solving for an Unknown in a Proportion"

Find the value of **c** that makes the fraction equivalent.

$$\frac{c}{36} = \frac{15}{6}$$

99) Assistent #48399 "48399 - Solving for an Unknown in a Proportion"

Find the value of **d** that makes the fraction equivalent.

$$\frac{d}{12} = \frac{15}{4}$$

100) Assistent #48400 "48400 - Solving for an Unknown in a Proportion"

Find the value of **d** that makes the fraction equivalent.

$$\frac{d}{36} = \frac{10}{6}$$

101) Assistent #48401 "48401 - Solving for an Unknown in a Proportion"

Find the value of **c** that makes the fraction equivalent.

$$\frac{c}{54} = \frac{10}{9}$$

102) Assistent #48402 "48402 - Solving for an Unknown in a Proportion"

Find the value of **b** that makes the fraction equivalent.

$$\frac{b}{27} = \frac{17}{9}$$

103) Assistent #48403 "48403 - Solving for an Unknown in a Proportion"

Find the value of **b** that makes the fraction equivalent.

$$\frac{b}{9} = \frac{17}{3}$$

104) Assistentment #48404 "48404 - Solving for an Unknown in a Proportion"
Find the value of **y** that makes the fraction equivalent.

$$\frac{y}{18} = \frac{14}{6}$$

105) Assistentment #48405 "48405 - Solving for an Unknown in a Proportion"
Find the value of **a** that makes the fraction equivalent.

$$\frac{a}{36} = \frac{11}{9}$$

106) Assistentment #48406 "48406 - Solving for an Unknown in a Proportion"
Find the value of **a** that makes the fraction equivalent.

$$\frac{a}{18} = \frac{11}{6}$$

107) Assistentment #48407 "48407 - Solving for an Unknown in a Proportion"
Find the value of **a** that makes the fraction equivalent.

$$\frac{a}{12} = \frac{14}{3}$$

108) Assistentment #48408 "48408 - Solving for an Unknown in a Proportion"

Find the value of **c** that makes the fraction equivalent.

$$\frac{c}{25} = \frac{12}{5}$$

109) Assistentment #48409 "48409 - Solving for an Unknown in a Proportion"

Find the value of **c** that makes the fraction equivalent.

$$\frac{c}{35} = \frac{18}{7}$$

110) Assistentment #48410 "48410 - Solving for an Unknown in a Proportion"

Find the value of **b** that makes the fraction equivalent.

$$\frac{b}{15} = \frac{14}{5}$$

Problem Set 6851 "Discount and Sales tax" id:[6851]

1) Assistent #46761 "46761 - Discount"

If a new lacrosse stick is labeled \$23, what would the **new price** be if the sign above it says "19% off"?

Round your answer to the nearest Cent.

2) Assistent #46762 "46762 - 46377 "

If a new tennis raquet is labeled \$29, what would the **new price** be if the sign above it says "76% off"?

Round your answer to the nearest Cent.

3) Assistent #46763 "46763 - 46377 "

If a new baseball bat is labeled \$28, what would the **new price** be if the sign above it says "47% off"?

Round your answer to the nearest Cent.

4) Assistent #46764 "46764 - 46377 "

If a new baseball bat is labeled \$52, what would the **new price** be if the sign above it says "28% off"?

Round your answer to the nearest Cent.

5) Assistent #46765 "46765 - 46377 "

If a new tennis raquet is labeled \$30, what would the **new price** be if the sign above it says "17% off"?

Round your answer to the nearest Cent.

6) Assistent #46766 "46766 - 46377 "

If a new tennis raquet is labeled \$37, what would the **new price** be if the sign above it says "26% off"?

Round your answer to the nearest Cent.

7) Assistent #46767 "46767 - 46377 "

If a new lacrosse stick is labeled \$47, what would the **new price** be if the sign above it says "72% off"?

Round your answer to the nearest Cent.

8) Assistent #46768 "46768 - 46377 "

If a new soccer ball is labeled \$28, what would the **new price** be if the sign above it says "45% off"?

Round your answer to the nearest Cent.

9) Assistent #46769 "46769 - 46377 "

If a new basketball is labeled \$20, what would the **new price** be if the sign above it says "16% off"?

Round your answer to the nearest Cent.

10) Assistent #46770 "46770 - 46377 "

If a new baseball bat is labeled \$25, what would the **new price** be if the sign above it says "50% off"?

Round your answer to the nearest Cent.

11) Assistent #46771 "46771 - Finding Price After Sales Tax"

If a new shirt sells for \$46, find the **total cost** if you were charged 2% sales tax.

Round your answer to the nearest Cent.

12) Assistent #46772 "46772 - Finding Price After Sales Tax"

If a new shirt sells for \$38, find the **total cost** if you were charged 4% sales tax.

Round your answer to the nearest Cent.

13) Assistent #46773 "46773 - Finding Price After Sales Tax"

If a new shirt sells for \$54, find the **total cost** if you were charged 2% sales tax.

Round your answer to the nearest Cent.

14) Assistent #46774 "46774 - Finding Price After Sales Tax"

If a new shirt sells for \$50, find the **total cost** if you were charged 3% sales tax.

Round your answer to the nearest Cent.

15) Assistent #46775 "46775 - Finding Price After Sales Tax"

If a new jacket sells for \$21, find the **total cost** if you were charged 5% sales tax.

Round your answer to the nearest Cent.

16) Assistent #46776 "46776 - Finding Price After Sales Tax"

If a new sweater sells for \$41, find the **total cost** if you were charged 6% sales tax.

Round your answer to the nearest Cent.

17) Assistent #46777 "46777 - Finding Price After Sales Tax"

If a new jacket sells for \$31, find the **total cost** if you were charged 3% sales tax.

Round your answer to the nearest Cent.

18) Assistent #46778 "46778 - Finding Price After Sales Tax"

If a new shirt sells for \$58, find the **total cost** if you were charged 4% sales tax.

Round your answer to the nearest Cent.

19) Assistent #46779 "46779 - Finding Price After Sales Tax"

If a new jacket sells for \$36, find the **total cost** if you were charged 6% sales tax.

Round your answer to the nearest Cent.

20) Assistent #46780 "46780 - Finding Price After Sales Tax"

If a new jacket sells for \$36, find the **total cost** if you were charged 6% sales tax.

Round your answer to the nearest Cent.

21) Assistent #46431 "46431 - Finding the Discounted Price"

If a new lacrosse stick is labeled \$51, what would the **new price** be if the sign above it says "29% off"?

Round your answer to the nearest Cent.

22) Assistent #46432 "46432 - Finding the Discounted Price"

If a new baseball bat is labeled \$21, what would the **new price** be if the sign above it says "78% off"?

Round your answer to the nearest Cent.

23) Assistent #46433 "46433 - Finding the Discounted Price"

If a new tennis raquet is labeled \$50, what would the **new price** be if the sign above it says "56% off"?

Round your answer to the nearest Cent.

24) Assistent #46434 "46434 - Finding the Discounted Price"

If a new basketball is labeled \$52, what would the **new price** be if the sign above it says "61% off"?

Round your answer to the nearest Cent.

25) Assistent #46435 "46435 - Finding the Discounted Price"

If a new tennis raquet is labeled \$46, what would the **new price** be if the sign above it says "75% off"?

Round your answer to the nearest Cent.

26) Assistent #46436 "46436 - Finding the Discounted Price"

If a new tennis raquet is labeled \$40, what would the **new price** be if the sign above it says "18% off"?

Round your answer to the nearest Cent.

27) Assistent #46437 "46437 - Finding the Discounted Price"

If a new lacrosse stick is labeled \$36, what would the **new price** be if the sign above it says "57% off"?

Round your answer to the nearest Cent.

28) Assistent #46438 "46438 - Finding the Discounted Price"

If a new baseball bat is labeled \$57, what would the **new price** be if the sign above it says

"45% off"?

Round your answer to the nearest Cent.

29) Assistent #46439 "46439 - Finding the Discounted Price"

If a new baseball bat is labeled \$49, what would the **new price** be if the sign above it says "70% off"?

Round your answer to the nearest Cent.

30) Assistent #46440 "46440 - Finding the Discounted Price"

If a new basketball is labeled \$26, what would the **new price** be if the sign above it says "55% off"?

Round your answer to the nearest Cent.

31) Assistent #46491 "46491 - Finding Price After Sales Tax"

If a new shirt sells for \$54, find the **total cost** if you were charged 4% sales tax.

Round your answer to the nearest Cent.

32) Assistent #46492 "46492 - Finding Price After Sales Tax"

If a new jacket sells for \$34, find the **total cost** if you were charged 5% sales tax.

Round your answer to the nearest Cent.

33) Assistent #46493 "46493 - Finding Price After Sales Tax"

If a new sweater sells for \$32, find the **total cost** if you were charged 3% sales tax.

Round your answer to the nearest Cent.

34) Assistent #46494 "46494 - Finding Price After Sales Tax"

If a new shirt sells for \$36, find the **total cost** if you were charged 6% sales tax.

Round your answer to the nearest Cent.

35) Assistent #46495 "46495 - Finding Price After Sales Tax"

If a new sweater sells for \$37, find the **total cost** if you were charged 2% sales tax.

Round your answer to the nearest Cent.

36) Assisment #46496 "46496 - Finding Price After Sales Tax"

If a new shirt sells for \$49, find the **total cost** if you were charged 3% sales tax.

Round your answer to the nearest Cent.

37) Assisment #46497 "46497 - Finding Price After Sales Tax"

If a new shirt sells for \$55, find the **total cost** if you were charged 5% sales tax.

Round your answer to the nearest Cent.

38) Assisment #46498 "46498 - Finding Price After Sales Tax"

If a new jacket sells for \$25, find the **total cost** if you were charged 6% sales tax.

Round your answer to the nearest Cent.

39) Assisment #46500 "46500 - Finding Price After Sales Tax"

If a new shirt sells for \$28, find the **total cost** if you were charged 6% sales tax.

Round your answer to the nearest Cent.

40) Assisment #47132 "47132 - 46377 "

If a new tennis raquet is labeled \$33, what would the **new price** be if the sign above it says "41% off"?

Round your answer to the nearest Cent.

41) Assisment #47133 "47133 - 46377 "

If a new lacrosse stick is labeled \$22, what would the **new price** be if the sign above it says "14% off"?

Round your answer to the nearest Cent.

42) Assisment #47134 "47134 - 46377 "

If a new lacrosse stick is labeled \$41, what would the **new price** be if the sign above it says "74% off"?

Round your answer to the nearest Cent.

43) Assisment #47135 "47135 - 46377 "

If a new soccer ball is labeled \$34, what would the **new price** be if the sign above it says "54% off"?

Round your answer to the nearest Cent.

44) Assisment #47136 "47136 - 46377 "

If a new soccer ball is labeled \$20, what would the **new price** be if the sign above it says "30% off"?

Round your answer to the nearest Cent.

45) Assisment #47137 "47137 - 46377 "

If a new soccer ball is labeled \$37, what would the **new price** be if the sign above it says "53% off"?

Round your answer to the nearest Cent.

46) Assisment #47138 "47138 - 46377 "

If a new basketball is labeled \$48, what would the **new price** be if the sign above it says "28% off"?

Round your answer to the nearest Cent.

47) Assisment #47139 "47139 - 46377 "

If a new baseball bat is labeled \$38, what would the **new price** be if the sign above it says "13% off"?

Round your answer to the nearest Cent.

48) Assisment #47140 "47140 - 46377 "

If a new soccer ball is labeled \$28, what would the **new price** be if the sign above it says "67% off"?

Round your answer to the nearest Cent.

49) Assisment #47141 "47141 - 46377 "

If a new basketball is labeled \$40, what would the **new price** be if the sign above it says "52% off"?

Round your answer to the nearest Cent.

50) Assisment #47152 "47152 - Finding Price After Sales Tax"

If a new shirt sells for \$36, find the **total cost** if you were charged 2% sales tax.

Round your answer to the nearest Cent.

51) Assisment #47153 "47153 - Finding Price After Sales Tax"

If a new shirt sells for \$58, find the **total cost** if you were charged 2% sales tax.

Round your answer to the nearest Cent.

52) Assisment #47154 "47154 - Finding Price After Sales Tax"

If a new sweater sells for \$22, find the **total cost** if you were charged 2% sales tax.

Round your answer to the nearest Cent.

53) Assisment #47155 "47155 - Finding Price After Sales Tax"

If a new shirt sells for \$35, find the **total cost** if you were charged 5% sales tax.

Round your answer to the nearest Cent.

54) Assisment #47156 "47156 - Finding Price After Sales Tax"

If a new jacket sells for \$45, find the **total cost** if you were charged 5% sales tax.

Round your answer to the nearest Cent.

55) Assisment #47157 "47157 - Finding Price After Sales Tax"

If a new jacket sells for \$52, find the **total cost** if you were charged 3% sales tax.

Round your answer to the nearest Cent.

56) Assisment #47158 "47158 - Finding Price After Sales Tax"

If a new jacket sells for \$37, find the **total cost** if you were charged 3% sales tax.

Round your answer to the nearest Cent.

57) Assisment #47159 "47159 - Finding Price After Sales Tax"

If a new jacket sells for \$32, find the **total cost** if you were charged 5% sales tax.

Round your answer to the nearest Cent.

58) Assisment #47160 "47160 - Finding Price After Sales Tax"

If a new shirt sells for \$26, find the **total cost** if you were charged 6% sales tax.

Round your answer to the nearest Cent.

59) Assisment #47161 "47161 - Finding Price After Sales Tax"

If a new jacket sells for \$59, find the **total cost** if you were charged 3% sales tax.

Round your answer to the nearest Cent.

60) Assisment #47142 "47142 - 46377 "

If a new tennis raquet is labeled \$26, what would the **new price** be if the sign above it says "16% off"?

Round your answer to the nearest Cent.

61) Assisment #47143 "47143 - 46377 "

If a new basketball is labeled \$54, what would the **new price** be if the sign above it says "72% off"?

Round your answer to the nearest Cent.

62) Assisment #47144 "47144 - 46377 "

If a new soccer ball is labeled \$22, what would the **new price** be if the sign above it says "38% off"?

Round your answer to the nearest Cent.

63) Assisment #47145 "47145 - 46377 "

If a new lacrosse stick is labeled \$20, what would the **new price** be if the sign above it says "44% off"?

Round your answer to the nearest Cent.

64) Assisment #47146 "47146 - 46377 "

If a new baseball bat is labeled \$44, what would the **new price** be if the sign above it says "52% off"?

Round your answer to the nearest Cent.

65) Assisment #47147 "47147 - 46377 "

If a new soccer ball is labeled \$38, what would the **new price** be if the sign above it says "31% off"?

Round your answer to the nearest Cent.

66) Assistment #47148 "47148 - 46377 "

If a new lacrosse stick is labeled \$45, what would the **new price** be if the sign above it says "53% off"?

Round your answer to the nearest Cent.

67) Assistment #47149 "47149 - 46377 "

If a new soccer ball is labeled \$42, what would the **new price** be if the sign above it says "40% off"?

Round your answer to the nearest Cent.

68) Assistment #47150 "47150 - 46377 "

If a new tennis raquet is labeled \$55, what would the **new price** be if the sign above it says "70% off"?

Round your answer to the nearest Cent.

69) Assistment #47151 "47151 - 46377 "

If a new basketball is labeled \$37, what would the **new price** be if the sign above it says "23% off"?

Round your answer to the nearest Cent.

70) Assistment #47162 "47162 - Finding Price After Sales Tax"

If a new sweater sells for \$36, find the **total cost** if you were charged 2% sales tax.

Round your answer to the nearest Cent.

71) Assistment #47163 "47163 - Finding Price After Sales Tax"

If a new shirt sells for \$47, find the **total cost** if you were charged 2% sales tax.

Round your answer to the nearest Cent.

72) Assistment #47164 "47164 - Finding Price After Sales Tax"

If a new sweater sells for \$27, find the **total cost** if you were charged 3% sales tax.

Round your answer to the nearest Cent.

73) Assistment #47165 "47165 - Finding Price After Sales Tax"

If a new jacket sells for \$43, find the **total cost** if you were charged 2% sales tax.

Round your answer to the nearest Cent.

74) Assistment #47166 "47166 - Finding Price After Sales Tax"

If a new shirt sells for \$58, find the **total cost** if you were charged 4% sales tax.

Round your answer to the nearest Cent.

75) Assistment #47167 "47167 - Finding Price After Sales Tax"

If a new jacket sells for \$38, find the **total cost** if you were charged 2% sales tax.

Round your answer to the nearest Cent.

76) Assistment #47168 "47168 - Finding Price After Sales Tax"

If a new jacket sells for \$33, find the **total cost** if you were charged 2% sales tax.

Round your answer to the nearest Cent.

77) Assistment #47169 "47169 - Finding Price After Sales Tax"

If a new shirt sells for \$27, find the **total cost** if you were charged 4% sales tax.

Round your answer to the nearest Cent.

78) Assistment #47170 "47170 - Finding Price After Sales Tax"

If a new jacket sells for \$42, find the **total cost** if you were charged 5% sales tax.

Round your answer to the nearest Cent.

79) Assistment #47171 "47171 - Finding Price After Sales Tax"

If a new jacket sells for \$22, find the **total cost** if you were charged 5% sales tax.

Round your answer to the nearest Cent.

80) Assistment #47495 "47495 - 46377 "

If a new soccer ball is labeled \$28, what would the **new price** be if the sign above it says "10% off"?

Round your answer to the nearest Cent.

81) Assistment #47496 "47496 - 46377 "

If a new soccer ball is labeled \$34, what would the **new price** be if the sign above it says "33% off"?

Round your answer to the nearest Cent.

82) Assistment #47497 "47497 - 46377 "

If a new lacrosse stick is labeled \$53, what would the **new price** be if the sign above it says "55% off"?

Round your answer to the nearest Cent.

83) Assistment #47498 "47498 - 46377 "

If a new basketball is labeled \$47, what would the **new price** be if the sign above it says "59% off"?

Round your answer to the nearest Cent.

84) Assistment #47499 "47499 - 46377 "

If a new lacrosse stick is labeled \$32, what would the **new price** be if the sign above it says "18% off"?

Round your answer to the nearest Cent.

85) Assistment #47500 "47500 - 46377 "

If a new soccer ball is labeled \$33, what would the **new price** be if the sign above it says "70% off"?

Round your answer to the nearest Cent.

86) Assistment #47501 "47501 - 46377 "

If a new tennis raquet is labeled \$55, what would the **new price** be if the sign above it says "12% off"?

Round your answer to the nearest Cent.

87) Assistment #47502 "47502 - 46377 "

If a new basketball is labeled \$43, what would the **new price** be if the sign above it says "41% off"?

Round your answer to the nearest Cent.

88) Assistment #47503 "47503 - 46377 "

If a new lacrosse stick is labeled \$48, what would the **new price** be if the sign above it says "61% off"?

Round your answer to the nearest Cent.

89) Assistment #47504 "47504 - 46377 "

If a new soccer ball is labeled \$33, what would the **new price** be if the sign above it says "15% off"?

Round your answer to the nearest Cent.

90) Assistment #47515 "47515 - Finding Price After Sales Tax"

If a new shirt sells for \$45, find the **total cost** if you were charged 5% sales tax.

Round your answer to the nearest Cent.

91) Assistment #47516 "47516 - Finding Price After Sales Tax"

If a new jacket sells for \$32, find the **total cost** if you were charged 3% sales tax.

Round your answer to the nearest Cent.

92) Assistment #47517 "47517 - Finding Price After Sales Tax"

If a new sweater sells for \$39, find the **total cost** if you were charged 2% sales tax.

Round your answer to the nearest Cent.

93) Assistment #47518 "47518 - Finding Price After Sales Tax"

If a new sweater sells for \$24, find the **total cost** if you were charged 2% sales tax.

Round your answer to the nearest Cent.

94) Assistment #47519 "47519 - Finding Price After Sales Tax"

If a new sweater sells for \$50, find the **total cost** if you were charged 4% sales tax.

Round your answer to the nearest Cent.

95) Assistment #47520 "47520 - Finding Price After Sales Tax"

If a new jacket sells for \$38, find the **total cost** if you were charged 6% sales tax.

Round your answer to the nearest Cent.

96) Assistment #47521 "47521 - Finding Price After Sales Tax"

If a new jacket sells for \$47, find the **total cost** if you were charged 3% sales tax.

Round your answer to the nearest Cent.

97) Assistment #47522 "47522 - Finding Price After Sales Tax"

If a new jacket sells for \$38, find the **total cost** if you were charged 3% sales tax.

Round your answer to the nearest Cent.

98) Assistment #47523 "47523 - Finding Price After Sales Tax"

If a new jacket sells for \$20, find the **total cost** if you were charged 4% sales tax.

Round your answer to the nearest Cent.

99) Assistment #47524 "47524 - Finding Price After Sales Tax"

If a new jacket sells for \$57, find the **total cost** if you were charged 6% sales tax.

Round your answer to the nearest Cent.

Problem Set 6895 "Scale Drawings" id:[6895]**1) Assistment #47638 "47638 - Scale"**

A map has a scale of 5 in. = 18 mi. If you measured the distance between two cities to be 20 in. on the map, how many miles would it actually be?

If necessary, round your answer to the nearest tenth.

2) Assistment #47639 "47639 - Scale"

A map has a scale of 3 in. = 8 mi. If you measured the distance between two cities to be 16 in. on the map, how many miles would it actually be?

If necessary, round your answer to the nearest tenth.

3) Assistment #47640 "47640 - Scale"

A map has a scale of 4 in. = 18 mi. If you measured the distance between two cities to be 26 in. on the map, how many miles would it actually be?

If necessary, round your answer to the nearest tenth.

4) Assistment #47641 "47641 - Scale"

A map has a scale of 2 in. = 11 mi. If you measured the distance between two cities to be 22 in. on the map, how many miles would it actually be?

If necessary, round your answer to the nearest tenth.

5) Assistment #47642 "47642 - Scale"

A map has a scale of 4 in. = 15 mi. If you measured the distance between two cities to be 18 in. on the map, how many miles would it actually be?

If necessary, round your answer to the nearest tenth.

6) Assistment #47643 "47643 - Scale"

A map has a scale of 5 in. = 18 mi. If you measured the distance between two cities to be 20 in. on the map, how many miles would it actually be?

If necessary, round your answer to the nearest tenth.

7) Assistment #47644 "47644 - Scale"

A map has a scale of 6 in. = 10 mi. If you measured the distance between two cities to be 15 in. on the map, how many miles would it actually be?

If necessary, round your answer to the nearest tenth.

8) Assistment #47645 "47645 - Scale"

A map has a scale of 2 in. = 15 mi. If you measured the distance between two cities to be 15 in. on the map, how many miles would it actually be?

If necessary, round your answer to the nearest tenth.

9) Assistment #47646 "47646 - Scale"

A map has a scale of 5 in. = 11 mi. If you measured the distance between two cities to be 29 in. on the map, how many miles would it actually be?

If necessary, round your answer to the nearest tenth.

10) Assistment #47647 "47647 - Scale"

A map has a scale of 6 in. = 11 mi. If you measured the distance between two cities to be 26 in. on the map, how many miles would it actually be?

If necessary, round your answer to the nearest tenth.

11) Assistment #47648 "47648 - Scale"

A map has a scale of 4 in. = 16 mi. If you measured the distance between two cities to be 23 in. on the map, how many miles would it actually be?

If necessary, round your answer to the nearest tenth.

12) Assistment #47649 "47649 - Scale"

A map has a scale of 5 in. = 11 mi. If you measured the distance between two cities to be 16 in. on the map, how many miles would it actually be?

If necessary, round your answer to the nearest tenth.

13) Assistment #47650 "47650 - Scale"

A map has a scale of 5 in. = 11 mi. If you measured the distance between two cities to

be 25 in. on the map, how many miles would it actually be?

If necessary, round your answer to the nearest tenth.

14) Assistment #47651 "47651 - Scale"

A map has a scale of 2 in. = 9 mi. If you measured the distance between two cities to be 29 in. on the map, how many miles would it actually be?

If necessary, round your answer to the nearest tenth.

15) Assistment #47652 "47652 - Scale"

A map has a scale of 6 in. = 8 mi. If you measured the distance between two cities to be 24 in. on the map, how many miles would it actually be?

If necessary, round your answer to the nearest tenth.

16) Assistment #47653 "47653 - Scale"

A map has a scale of 3 in. = 19 mi. If you measured the distance between two cities to be 16 in. on the map, how many miles would it actually be?

If necessary, round your answer to the nearest tenth.

17) Assistment #47654 "47654 - Scale"

A map has a scale of 6 in. = 9 mi. If you measured the distance between two cities to be 25 in. on the map, how many miles would it actually be?

If necessary, round your answer to the nearest tenth.

18) Assistment #47655 "47655 - Scale"

A map has a scale of 4 in. = 15 mi. If you measured the distance between two cities to be 19 in. on the map, how many miles would it actually be?

If necessary, round your answer to the nearest tenth.

19) Assistment #47656 "47656 - Scale"

A map has a scale of 5 in. = 16 mi. If you measured the distance between two cities to be 16 in. on the map, how many miles would it actually be?

If necessary, round your answer to the nearest tenth.

20) Assistment #47657 "47657 - Scale"

A map has a scale of 3 in. = 18 mi. If you measured the distance between two cities to be 23 in. on the map, how many miles would it actually be?

If necessary, round your answer to the nearest tenth.

21) Assistment #47658 "47658 - Scale"

A map has a scale of 2 in. = 14 mi. If you measured the distance between two cities to be 20 in. on the map, how many miles would it actually be?

If necessary, round your answer to the nearest tenth.

22) Assistment #47659 "47659 - Scale"

A map has a scale of 6 in. = 8 mi. If you measured the distance between two cities to be 25 in. on the map, how many miles would it actually be?

If necessary, round your answer to the nearest tenth.

23) Assistment #47660 "47660 - Scale"

A map has a scale of 5 in. = 12 mi. If you measured the distance between two cities to be 18 in. on the map, how many miles would it actually be?

If necessary, round your answer to the nearest tenth.

24) Assistment #47661 "47661 - Scale"

A map has a scale of 4 in. = 18 mi. If you measured the distance between two cities to be 20 in. on the map, how many miles would it actually be?

If necessary, round your answer to the nearest tenth.

25) Assistment #47662 "47662 - Scale"

A map has a scale of 2 in. = 14 mi. If you measured the distance between two cities to be 27 in. on the map, how many miles would it actually be?

If necessary, round your answer to the nearest tenth.

26) Assistment #47663 "47663 - Scale"

A map has a scale of 4 in. = 17 mi. If you measured the distance between two cities to be 24 in. on the map, how many miles would it actually be?

If necessary, round your answer to the nearest tenth.

27) Assistment #47664 "47664 - Scale"

A map has a scale of 3 in. = 14 mi. If you measured the distance between two cities to be 15 in. on the map, how many miles would it actually be?

If necessary, round your answer to the nearest tenth.

28) Assistment #47665 "47665 - Scale"

A map has a scale of 4 in. = 8 mi. If you measured the distance between two cities to be 17 in. on the map, how many miles would it actually be?

If necessary, round your answer to the nearest tenth.

29) Assistment #47666 "47666 - Scale"

A map has a scale of 3 in. = 16 mi. If you measured the distance between two cities to be 23 in. on the map, how many miles would it actually be?

If necessary, round your answer to the nearest tenth.

30) Assistment #47667 "47667 - Scale"

A map has a scale of 5 in. = 12 mi. If you measured the distance between two cities to be 18 in. on the map, how many miles would it actually be?

If necessary, round your answer to the nearest tenth.

31) Assistment #47668 "47668 - Scale"

A map has a scale of 5 in. = 8 mi. If you measured the distance between two cities to be 27 in. on the map, how many miles would it actually be?

If necessary, round your answer to the nearest tenth.

32) Assistment #47669 "47669 - Scale"

A map has a scale of 2 in. = 11 mi. If you measured the distance between two cities to be 18 in. on the map, how many miles would it actually be?

If necessary, round your answer to the nearest tenth.

33) Assistment #47670 "47670 - Scale"

A map has a scale of 5 in. = 11 mi. If you measured the distance between two cities to be 25 in. on the map, how many miles would it actually be?

If necessary, round your answer to the nearest tenth.

34) Assistment #47671 "47671 - Scale"

A map has a scale of 3 in. = 16 mi. If you measured the distance between two cities to be 16 in. on the map, how many miles would it actually be?

If necessary, round your answer to the nearest tenth.

35) Assistment #47672 "47672 - Scale"

A map has a scale of 5 in. = 16 mi. If you measured the distance between two cities to be 29 in. on the map, how many miles would it actually be?

If necessary, round your answer to the nearest tenth.

36) Assistment #47673 "47673 - Scale"

A map has a scale of 5 in. = 18 mi. If you measured the distance between two cities to be 25 in. on the map, how many miles would it actually be?

If necessary, round your answer to the nearest tenth.

37) Assistment #47674 "47674 - Scale"

A map has a scale of 6 in. = 12 mi. If you measured the distance between two cities to be 22 in. on the map, how many miles would it actually be?

If necessary, round your answer to the nearest tenth.

38) Assistment #47675 "47675 - Scale"

A map has a scale of 4 in. = 9 mi. If you measured the distance between two cities to be 20 in. on the map, how many miles would it actually be?

If necessary, round your answer to the nearest tenth.

39) Assistment #47676 "47676 - Scale"

A map has a scale of 2 in. = 17 mi. If you measured the distance between two cities to be 19 in. on the map, how many miles would it actually be?

If necessary, round your answer to the nearest tenth.

40) Assistment #47677 "47677 - Scale"

A map has a scale of 6 in. = 9 mi. If you measured the distance between two cities to be 17 in. on the map, how many miles would it actually be?

If necessary, round your answer to the nearest tenth.

41) Assistment #47678 "47678 - Scale"

A map has a scale of 4 in. = 15 mi. If you measured the distance between two cities to be 28 in. on the map, how many miles would it actually be?

If necessary, round your answer to the nearest tenth.

42) Assistment #47679 "47679 - Scale"

A map has a scale of 2 in. = 9 mi. If you measured the distance between two cities to be 23 in. on the map, how many miles would it actually be?

If necessary, round your answer to the nearest tenth.

43) Assistment #47680 "47680 - Scale"

A map has a scale of 2 in. = 9 mi. If you measured the distance between two cities to be 27 in. on the map, how many miles would it actually be?

If necessary, round your answer to the nearest tenth.

44) Assistment #47681 "47681 - Scale"

A map has a scale of 5 in. = 11 mi. If you measured the distance between two cities to be 19 in. on the map, how many miles would it actually be?

If necessary, round your answer to the nearest tenth.

45) Assistment #47682 "47682 - Scale"

A map has a scale of 5 in. = 10 mi. If you measured the distance between two cities to be 27 in. on the map, how many miles would it actually be?

If necessary, round your answer to the nearest tenth.

46) Assistment #47683 "47683 - Scale"

A map has a scale of 5 in. = 11 mi. If you measured the distance between two cities to be 26 in. on the map, how many miles would it actually be?

If necessary, round your answer to the nearest tenth.

47) Assistment #47684 "47684 - Scale"

A map has a scale of 6 in. = 10 mi. If you measured the distance between two cities to be 23 in. on the map, how many miles would it actually be?

If necessary, round your answer to the nearest tenth.

48) Assistment #47685 "47685 - Scale"

A map has a scale of 6 in. = 18 mi. If you measured the distance between two cities to be 26 in. on the map, how many miles would it actually be?

If necessary, round your answer to the nearest tenth.

49) Assistment #47686 "47686 - Scale"

A map has a scale of 3 in. = 11 mi. If you measured the distance between two cities to be 20 in. on the map, how many miles would it actually be?

If necessary, round your answer to the nearest tenth.

50) Assistment #47687 "47687 - Scale"

A map has a scale of 3 in. = 13 mi. If you measured the distance between two cities to be 15 in. on the map, how many miles would it actually be?

If necessary, round your answer to the nearest tenth.

51) Assistment #47688 "47688 - Scale"

A map has a scale of 6 in. = 16 mi. If you measured the distance between two cities to be 19 in. on the map, how many miles would it actually be?

If necessary, round your answer to the nearest tenth.

52) Assistment #47689 "47689 - Scale"

A map has a scale of 5 in. = 19 mi. If you measured the distance between two cities to be 28 in. on the map, how many miles would it actually be?

If necessary, round your answer to the nearest tenth.

53) Assistment #47690 "47690 - Scale"

A map has a scale of 2 in. = 8 mi. If you measured the distance between two cities to be 23 in. on the map, how many miles would it actually be?

If necessary, round your answer to the nearest tenth.

54) Assistment #47691 "47691 - Scale"

A map has a scale of 6 in. = 15 mi. If you measured the distance between two cities to be 20 in. on the map, how many miles would it actually be?

If necessary, round your answer to the nearest tenth.

55) Assistment #47692 "47692 - Scale"

A map has a scale of 4 in. = 13 mi. If you measured the distance between two cities to be 29 in. on the map, how many miles would it actually be?

If necessary, round your answer to the nearest tenth.

56) Assistment #47693 "47693 - Scale"

A map has a scale of 5 in. = 10 mi. If you measured the distance between two cities to be 16 in. on the map, how many miles would it actually be?

If necessary, round your answer to the nearest tenth.

57) Assistment #47694 "47694 - Scale"

A map has a scale of 5 in. = 10 mi. If you measured the distance between two cities to be 25 in. on the map, how many miles would it actually be?

If necessary, round your answer to the nearest tenth.

58) Assistment #47695 "47695 - Scale"

A map has a scale of 6 in. = 12 mi. If you measured the distance between two cities to be 20 in. on the map, how many miles would it actually be?

If necessary, round your answer to the nearest tenth.

59) Assistment #47696 "47696 - Scale"

A map has a scale of 4 in. = 13 mi. If you measured the distance between two cities to be 15 in. on the map, how many miles would it actually be?

If necessary, round your answer to the nearest tenth.

60) Assistment #47697 "47697 - Scale"

A map has a scale of 5 in. = 11 mi. If you measured the distance between two cities to be 15 in. on the map, how many miles would it actually be?

If necessary, round your answer to the nearest tenth.

61) Assistment #47698 "47698 - Scale"

A map has a scale of 2 in. = 18 mi. If you measured the distance between two cities to be 16 in. on the map, how many miles would it actually be?

If necessary, round your answer to the nearest tenth.

62) Assistment #47699 "47699 - Scale"

A map has a scale of 6 in. = 8 mi. If you measured the distance between two cities to be 27 in. on the map, how many miles would it actually be?

If necessary, round your answer to the nearest tenth.

63) Assistment #47700 "47700 - Scale"

A map has a scale of 4 in. = 15 mi. If you measured the distance between two cities to be 27 in. on the map, how many miles would it actually be?

If necessary, round your answer to the nearest tenth.

64) Assistment #47701 "47701 - Scale"

A map has a scale of 4 in. = 19 mi. If you measured the distance between two cities to be 26 in. on the map, how many miles would it actually be?

If necessary, round your answer to the nearest tenth.

65) Assistment #47702 "47702 - Scale"

A map has a scale of 5 in. = 10 mi. If you measured the distance between two cities to be 17 in. on the map, how many miles would it actually be?

If necessary, round your answer to the nearest tenth.

66) Assistment #47703 "47703 - Scale"

A map has a scale of 2 in. = 10 mi. If you measured the distance between two cities to be 25 in. on the map, how many miles would it actually be?

If necessary, round your answer to the nearest tenth.

67) Assistment #47704 "47704 - Scale"

A map has a scale of 5 in. = 15 mi. If you measured the distance between two cities to be 26 in. on the map, how many miles would it actually be?

If necessary, round your answer to the nearest tenth.

68) Assistment #47705 "47705 - Scale"

A map has a scale of 2 in. = 18 mi. If you measured the distance between two cities to be 26 in. on the map, how many miles would it actually be?

If necessary, round your answer to the nearest tenth.

69) Assistment #47706 "47706 - Scale"

A map has a scale of 5 in. = 17 mi. If you measured the distance between two cities to be 23 in. on the map, how many miles would it actually be?

If necessary, round your answer to the nearest tenth.

70) Assistment #47707 "47707 - Scale"

A map has a scale of 2 in. = 15 mi. If you measured the distance between two cities to be 24 in. on the map, how many miles would it actually be?

If necessary, round your answer to the nearest tenth.

71) Assistment #47765 "47765 - Scale"

A map has a scale of 5 in. = 18 mi. If you measured the distance between two cities to be 19 in. on the map, how many miles would it actually be?

If necessary, round your answer to the nearest tenth.

72) Assistment #47766 "47766 - Scale"

A map has a scale of 6 in. = 10 mi. If you measured the distance between two cities to be 27 in. on the map, how many miles would it actually be?

If necessary, round your answer to the nearest tenth.

73) Assistment #47767 "47767 - Scale"

A map has a scale of 5 in. = 12 mi. If you measured the distance between two cities to be 16 in. on the map, how many miles would it actually be?

If necessary, round your answer to the nearest tenth.

74) Assistment #47768 "47768 - Scale"

A map has a scale of 6 in. = 8 mi. If you measured the distance between two cities to be 19 in. on the map, how many miles would it actually be?

If necessary, round your answer to the nearest tenth.

75) Assistment #47769 "47769 - Scale"

A map has a scale of 5 in. = 18 mi. If you measured the distance between two cities to be 20 in. on the map, how many miles would it actually be?

If necessary, round your answer to the nearest tenth.

76) Assistment #47770 "47770 - Scale"

A map has a scale of 5 in. = 9 mi. If you measured the distance between two cities to be 15 in. on the map, how many miles would it actually be?

If necessary, round your answer to the nearest tenth.

77) Assistment #47771 "47771 - Scale"

A map has a scale of 6 in. = 10 mi. If you measured the distance between two cities to be 21 in. on the map, how many miles would it actually be?

If necessary, round your answer to the nearest tenth.

78) Assistment #47772 "47772 - Scale"

A map has a scale of 5 in. = 16 mi. If you measured the distance between two cities to be 24 in. on the map, how many miles would it actually be?

If necessary, round your answer to the nearest tenth.

79) Assistment #47773 "47773 - Scale"

A map has a scale of 5 in. = 8 mi. If you measured the distance between two cities to be 15 in. on the map, how many miles would it actually be?

If necessary, round your answer to the nearest tenth.

80) Assistment #47774 "47774 - Scale"

A map has a scale of 5 in. = 18 mi. If you measured the distance between two cities to be 17 in. on the map, how many miles would it actually be?

If necessary, round your answer to the nearest tenth.

81) Assistment #47775 "47775 - Scale"

A map has a scale of 6 in. = 8 mi. If you measured the distance between two cities to be 20 in. on the map, how many miles would it actually be?

If necessary, round your answer to the nearest tenth.

82) Assistment #47776 "47776 - Scale"

A map has a scale of 6 in. = 16 mi. If you measured the distance between two cities to be 29 in. on the map, how many miles would it actually be?

If necessary, round your answer to the nearest tenth.

83) Assistment #47777 "47777 - Scale"

A map has a scale of 6 in. = 19 mi. If you measured the distance between two cities to be 15 in. on the map, how many miles would it actually be?

If necessary, round your answer to the nearest tenth.

84) Assistment #47778 "47778 - Scale"

A map has a scale of 5 in. = 19 mi. If you measured the distance between two cities to be 18 in. on the map, how many miles would it actually be?

If necessary, round your answer to the nearest tenth.

85) Assistment #47779 "47779 - Scale"

A map has a scale of 3 in. = 11 mi. If you measured the distance between two cities to be 25 in. on the map, how many miles would it actually be?

If necessary, round your answer to the nearest tenth.

86) Assistment #47780 "47780 - Scale"

A map has a scale of 2 in. = 14 mi. If you measured the distance between two cities to be 22 in. on the map, how many miles would it actually be?

If necessary, round your answer to the nearest tenth.

87) Assistment #47781 "47781 - Scale"

A map has a scale of 6 in. = 11 mi. If you measured the distance between two cities to be 22 in. on the map, how many miles would it actually be?

If necessary, round your answer to the nearest tenth.

88) Assistment #47782 "47782 - Scale"

A map has a scale of 6 in. = 13 mi. If you measured the distance between two cities to be 23 in. on the map, how many miles would it actually be?

If necessary, round your answer to the nearest tenth.

89) Assistment #47783 "47783 - Scale"

A map has a scale of 5 in. = 11 mi. If you measured the distance between two cities to be 15 in. on the map, how many miles would it actually be?

If necessary, round your answer to the nearest tenth.

90) Assistment #47784 "47784 - Scale"

A map has a scale of 5 in. = 10 mi. If you measured the distance between two cities to be 23 in. on the map, how many miles would it actually be?

If necessary, round your answer to the nearest tenth.

91) Assistment #47785 "47785 - Scale"

A map has a scale of 3 in. = 12 mi. If you measured the distance between two cities to be 20 in. on the map, how many miles would it actually be?

If necessary, round your answer to the nearest tenth.

92) Assistment #47786 "47786 - Scale"

A map has a scale of 4 in. = 13 mi. If you measured the distance between two cities to be 24 in. on the map, how many miles would it actually be?

If necessary, round your answer to the nearest tenth.

93) Assistment #47787 "47787 - Scale"

A map has a scale of 5 in. = 8 mi. If you measured the distance between two cities to be 18 in. on the map, how many miles would it actually be?

If necessary, round your answer to the nearest tenth.

94) Assistment #47788 "47788 - Scale"

A map has a scale of 6 in. = 11 mi. If you measured the distance between two cities to be 25 in. on the map, how many miles would it actually be?

If necessary, round your answer to the nearest tenth.

95) Assistment #47789 "47789 - Scale"

A map has a scale of 3 in. = 13 mi. If you measured the distance between two cities to be 17 in. on the map, how many miles would it actually be?

If necessary, round your answer to the nearest tenth.

96) Assistment #47790 "47790 - Scale"

A map has a scale of 6 in. = 17 mi. If you measured the distance between two cities to be 20 in. on the map, how many miles would it actually be?

If necessary, round your answer to the nearest tenth.

97) Assistment #47791 "47791 - Scale"

A map has a scale of 5 in. = 19 mi. If you measured the distance between two cities to be 20 in. on the map, how many miles would it actually be?

If necessary, round your answer to the nearest tenth.

98) Assistment #47792 "47792 - Scale"

A map has a scale of 5 in. = 18 mi. If you measured the distance between two cities to be 15 in. on the map, how many miles would it actually be?

If necessary, round your answer to the nearest tenth.

99) Assistment #47793 "47793 - Scale"

A map has a scale of 6 in. = 11 mi. If you measured the distance between two cities to be 22 in. on the map, how many miles would it actually be?

If necessary, round your answer to the nearest tenth.

100) Assistment #47794 "47794 - Scale"

A map has a scale of 2 in. = 16 mi. If you measured the distance between two cities to be 19 in. on the map, how many miles would it actually be?

If necessary, round your answer to the nearest tenth.

Problem Set 7179 "Least Common Multiple - In a Word Problem" id:[7179]

1) Assistent #47586 "47586 - 46083 - Least Common Multiple"

Anthony plays baseball every 2 days and soccer every 4 days. The last day he played both sports on the same day was on May 5th. What is the next day in May that he will play both baseball and soccer on the same day?

2) Assistent #47587 "47587 - 46083 - Least Common Multiple"

Adam plays basketball every 2 days and lacrosse every 5 days. The last day he played both sports on the same day was on August 9th. What is the next day in August that he will play both basketball and lacrosse on the same day?

3) Assistent #47588 "47588 - 46083 - Least Common Multiple"

Chris plays soccer every 2 days and golf every 6 days. The last day he played both sports on the same day was on September 13th. What is the next day in September that he will play both golf and soccer on the same day?

4) Assistent #47589 "47589 - 46083 - Least Common Multiple"

Adam plays basketball every 3 days and football every 4 days. The last day he played both sports on the same day was on April 10th. What is the next day in April that he will play both basketball and football on the same day?

5) Assistent #47590 "47590 - 46083 - Least Common Multiple"

John plays baseball every 3 days and lacrosse every 5 days. The last day he played both sports on the same day was on May 12th. What is the next day in May that he will play both baseball and lacrosse on the same day?

6) Assistent #47591 "47591 - 46083 - Least Common Multiple"

Steve plays soccer every 3 days and lacrosse every 6 days. The last day he played both sports on the same day was on April 12th. What is the next day in April that he will play both lacrosse and soccer on the same day?

7) Assistment #47592 "47592 - 46083 - Least Common Multiple"

Anthony plays basketball every 2 days and lacrosse every 4 days. The last day he played both sports on the same day was on September 15th. What is the next day in September that he will play both basketball and lacrosse on the same day?

8) Assistment #47593 "47593 - 46083 - Least Common Multiple"

Bob plays basketball every 2 days and football every 5 days. The last day he played both sports on the same day was on September 6th. What is the next day in September that he will play both basketball and football on the same day?

9) Assistment #47594 "47594 - 46083 - Least Common Multiple"

Adam plays basketball every 2 days and golf every 6 days. The last day he played both sports on the same day was on October 13th. What is the next day in October that he will play both basketball and golf on the same day?

10) Assistment #47595 "47595 - 46083 - Least Common Multiple"

Bob plays baseball every 3 days and golf every 4 days. The last day he played both sports on the same day was on August 11th. What is the next day in August that he will play both baseball and golf on the same day?

11) Assistment #47596 "47596 - 46083 - Least Common Multiple"

Steve plays soccer every 2 days and football every 4 days. The last day he played both sports on the same day was on October 10th. What is the next day in October that he will play both football and soccer on the same day?

12) Assistment #47597 "47597 - 46083 - Least Common Multiple"

Adam plays baseball every 2 days and golf every 5 days. The last day he played both sports on the same day was on May 9th. What is the next day in May that he will play both baseball and golf on the same day?

13) Assistment #47598 "47598 - 46083 - Least Common Multiple"

Chris plays basketball every 2 days and lacrosse every 6 days. The last day he played both sports on the same day was on October 11th. What is the next day in October that he will play both basketball and lacrosse on the same day?

14) Assistment #47599 "47599 - 46083 - Least Common Multiple"

Bob plays soccer every 3 days and football every 4 days. The last day he played both sports on the same day was on July 8th. What is the next day in July that he will play both football and soccer on the same day?

15) Assistment #47600 "47600 - 46083 - Least Common Multiple"

Adam plays soccer every 3 days and lacrosse every 5 days. The last day he played both sports on the same day was on July 12th. What is the next day in July that he will play both lacrosse and soccer on the same day?

16) Assistment #47601 "47601 - 46083 - Least Common Multiple"

Adam plays baseball every 3 days and football every 6 days. The last day he played both sports on the same day was on July 15th. What is the next day in July that he will play both baseball and football on the same day?

17) Assistment #47602 "47602 - 46083 - Least Common Multiple"

Adam plays soccer every 2 days and football every 4 days. The last day he played both sports on the same day was on June 8th. What is the next day in June that he will play both football and soccer on the same day?

18) Assistment #47603 "47603 - 46083 - Least Common Multiple"

Chris plays basketball every 2 days and football every 5 days. The last day he played both sports on the same day was on June 13th. What is the next day in June that he will play both basketball and football on the same day?

19) Assistment #47604 "47604 - 46083 - Least Common Multiple"

John plays basketball every 2 days and football every 6 days. The last day he played both sports on the same day was on July 10th. What is the next day in July that he will play both basketball and football on the same day?

20) Assistment #47605 "47605 - 46083 - Least Common Multiple"

Anthony plays soccer every 3 days and lacrosse every 4 days. The last day he played both sports on the same day was on August 12th. What is the next day in August that he will play both lacrosse and soccer on the same day?

21) Assistment #47606 "47606 - 46083 - Least Common Multiple"

John plays soccer every 2 days and football every 4 days. The last day he played both sports on the same day was on June 5th. What is the next day in June that he will play both football and soccer on the same day?

22) Assistment #47607 "47607 - 46083 - Least Common Multiple"

Bob plays soccer every 2 days and golf every 5 days. The last day he played both sports on the same day was on September 9th. What is the next day in September that he will play both golf and soccer on the same day?

23) Assistment #47608 "47608 - 46083 - Least Common Multiple"

Anthony plays baseball every 2 days and golf every 6 days. The last day he played both sports on the same day was on September 14th. What is the next day in September that he will play both baseball and golf on the same day?

24) Assistment #47609 "47609 - 46083 - Least Common Multiple"

Anthony plays soccer every 3 days and lacrosse every 4 days. The last day he played both sports on the same day was on April 12th. What is the next day in April that he will play both lacrosse and soccer on the same day?

25) Assistment #47610 "47610 - 46083 - Least Common Multiple"

Steve plays soccer every 3 days and football every 5 days. The last day he played both sports on the same day was on June 12th. What is the next day in June that he will play both football and soccer on the same day?

26) Assistment #47611 "47611 - 46083 - Least Common Multiple"

Chris plays soccer every 3 days and golf every 6 days. The last day he played both sports on the same day was on July 12th. What is the next day in July that he will play both golf and soccer on the same day?

27) Assistment #47612 "47612 - 46083 - Least Common Multiple"

John plays soccer every 2 days and lacrosse every 4 days. The last day he played both sports on the same day was on September 15th. What is the next day in September that he will play both lacrosse and soccer on the same day?

28) Assistment #47613 "47613 - 46083 - Least Common Multiple"

Adam plays basketball every 2 days and golf every 5 days. The last day he played both sports on the same day was on June 6th. What is the next day in June that he will play both basketball and golf on the same day?

29) Assistment #47614 "47614 - 46083 - Least Common Multiple"

Chris plays baseball every 2 days and lacrosse every 6 days. The last day he played both sports on the same day was on April 14th. What is the next day in April that he will play both baseball and lacrosse on the same day?

30) Assistment #47615 "47615 - 46083 - Least Common Multiple"

Adam plays basketball every 3 days and golf every 4 days. The last day he played both sports on the same day was on August 5th. What is the next day in August that he will play both basketball and golf on the same day?

31) Assistment #47616 "47616 - 46083 - Least Common Multiple"

Adam plays basketball every 2 days and lacrosse every 4 days. The last day he played both sports on the same day was on August 15th. What is the next day in August that he will play both basketball and lacrosse on the same day?

32) Assistment #47617 "47617 - 46083 - Least Common Multiple"

Anthony plays soccer every 2 days and football every 5 days. The last day he played both sports on the same day was on October 9th. What is the next day in October that he will play both football and soccer on the same day?

33) Assistment #47618 "47618 - 46083 - Least Common Multiple"

Chris plays baseball every 2 days and golf every 6 days. The last day he played both sports on the same day was on June 15th. What is the next day in June that he will play both baseball and golf on the same day?

34) Assistment #47619 "47619 - 46083 - Least Common Multiple"

John plays baseball every 3 days and football every 4 days. The last day he played both sports on the same day was on June 6th. What is the next day in June that he will play both baseball and football on the same day?

35) Assistment #47620 "47620 - 46083 - Least Common Multiple"

Steve plays soccer every 3 days and golf every 5 days. The last day he played both sports on the same day was on October 6th. What is the next day in October that he will play both golf and soccer on the same day?

36) Assistment #47621 "47621 - 46083 - Least Common Multiple"

Adam plays basketball every 3 days and golf every 6 days. The last day he played both sports on the same day was on May 8th. What is the next day in May that he will play both basketball and golf on the same day?

37) Assistment #47622 "47622 - 46083 - Least Common Multiple"

Adam plays basketball every 2 days and football every 4 days. The last day he played both sports on the same day was on August 8th. What is the next day in August that he will play both basketball and football on the same day?

38) Assistment #47623 "47623 - 46083 - Least Common Multiple"

Chris plays soccer every 2 days and lacrosse every 5 days. The last day he played both sports on the same day was on September 5th. What is the next day in September that he

will play both lacrosse and soccer on the same day?

39) Assistment #47624 "47624 - 46083 - Least Common Multiple"

Chris plays soccer every 2 days and lacrosse every 6 days. The last day he played both sports on the same day was on May 13th. What is the next day in May that he will play both lacrosse and soccer on the same day?

40) Assistment #47625 "47625 - 46083 - Least Common Multiple"

Chris plays soccer every 3 days and golf every 4 days. The last day he played both sports on the same day was on May 7th. What is the next day in May that he will play both golf and soccer on the same day?

41) Assistment #47626 "47626 - 46083 - Least Common Multiple"

Bob plays basketball every 2 days and golf every 4 days. The last day he played both sports on the same day was on October 9th. What is the next day in October that he will play both basketball and golf on the same day?

42) Assistment #47627 "47627 - 46083 - Least Common Multiple"

Steve plays soccer every 2 days and football every 5 days. The last day he played both sports on the same day was on October 11th. What is the next day in October that he will play both football and soccer on the same day?

43) Assistment #47628 "47628 - 46083 - Least Common Multiple"

Adam plays basketball every 2 days and golf every 6 days. The last day he played both sports on the same day was on June 5th. What is the next day in June that he will play both basketball and golf on the same day?

44) Assistment #47629 "47629 - 46083 - Least Common Multiple"

Steve plays baseball every 3 days and football every 4 days. The last day he played both sports on the same day was on October 9th. What is the next day in October that he will play both baseball and football on the same day?

45) Assistment #47630 "47630 - 46083 - Least Common Multiple"

Anthony plays basketball every 3 days and lacrosse every 5 days. The last day he played both sports on the same day was on July 15th. What is the next day in July that he will play both basketball and lacrosse on the same day?

46) Assistment #47631 "47631 - 46083 - Least Common Multiple"

Bob plays baseball every 3 days and lacrosse every 6 days. The last day he played both

sports on the same day was on April 13th. What is the next day in April that he will play both baseball and lacrosse on the same day?

47) Assistment #47632 "47632 - 46083 - Least Common Multiple"

Adam plays soccer every 2 days and football every 4 days. The last day he played both sports on the same day was on June 15th. What is the next day in June that he will play both football and soccer on the same day?

48) Assistment #47633 "47633 - 46083 - Least Common Multiple"

Chris plays baseball every 2 days and football every 5 days. The last day he played both sports on the same day was on April 8th. What is the next day in April that he will play both baseball and football on the same day?

49) Assistment #47634 "47634 - 46083 - Least Common Multiple"

Steve plays baseball every 2 days and football every 6 days. The last day he played both sports on the same day was on October 14th. What is the next day in October that he will play both baseball and football on the same day?

50) Assistment #47635 "47635 - 46083 - Least Common Multiple"

Bob plays baseball every 3 days and football every 4 days. The last day he played both sports on the same day was on August 10th. What is the next day in August that he will play both baseball and football on the same day?

Problem Set 6928 "Prime Factorization" id:[6928]

1) Assisment #49294 "49294 - Prime Factorization"

What is the prime factorization of 8?

Your answer should look like $11 \times 11 \times 5$. Use the "x" for the multiplication sign.

2) Assisment #49295 "49295 - Prime Factorization"

What is the prime factorization of 12?

Your answer should look like $11 \times 11 \times 5$. Use the "x" for the multiplication sign.

3) Assisment #49296 "49296 - Prime Factorization"

What is the prime factorization of 20?

Your answer should look like $11 \times 11 \times 5$. Use the "x" for the multiplication sign.

4) Assisment #49297 "49297 - Prime Factorization"

What is the prime factorization of 28?

Your answer should look like $11 \times 11 \times 5$. Use the "x" for the multiplication sign.

5) Assisment #49298 "49298 - Prime Factorization"

What is the prime factorization of 12?

Your answer should look like $11 \times 11 \times 5$. Use the "x" for the multiplication sign.

6) Assisment #49299 "49299 - Prime Factorization"

What is the prime factorization of 18?

Your answer should look like $11 \times 11 \times 5$. Use the "x" for the multiplication sign.

7) Assistent #49300 "49300 - Prime Factorization"

What is the prime factorization of 30?

Your answer should look like $11 \times 11 \times 5$. Use the "x" for the multiplication sign.

8) Assistent #49301 "49301 - Prime Factorization"

What is the prime factorization of 42?

Your answer should look like $11 \times 11 \times 5$. Use the "x" for the multiplication sign.

9) Assistent #49302 "49302 - Prime Factorization"

What is the prime factorization of 20?

Your answer should look like $11 \times 11 \times 5$. Use the "x" for the multiplication sign.

10) Assistent #49303 "49303 - Prime Factorization"

What is the prime factorization of 30?

Your answer should look like $11 \times 11 \times 5$. Use the "x" for the multiplication sign.

11) Assistent #49314 "49314 - Prime Factorization"

What is the prime factorization of 8?

Your answer should look like $11 \times 11 \times 5$. Use the "x" for the multiplication sign.

12) Assistent #49315 "49315 - Prime Factorization"

What is the prime factorization of 12?

Your answer should look like $11 \times 11 \times 5$. Use the "x" for the multiplication sign.

13) Assistent #49316 "49316 - Prime Factorization"

What is the prime factorization of 20?

Your answer should look like $11 \times 11 \times 5$. Use the "x" for the multiplication sign.

14) Assisment #49317 "49317 - Prime Factorization"

What is the prime factorization of 28?

Your answer should look like $11 \times 11 \times 5$. Use the "x" for the multiplication sign.

15) Assisment #49318 "49318 - Prime Factorization"

What is the prime factorization of 12?

Your answer should look like $11 \times 11 \times 5$. Use the "x" for the multiplication sign.

16) Assisment #49319 "49319 - Prime Factorization"

What is the prime factorization of 18?

Your answer should look like $11 \times 11 \times 5$. Use the "x" for the multiplication sign.

17) Assisment #49320 "49320 - Prime Factorization"

What is the prime factorization of 30?

Your answer should look like $11 \times 11 \times 5$. Use the "x" for the multiplication sign.

18) Assisment #49321 "49321 - Prime Factorization"

What is the prime factorization of 42?

Your answer should look like $11 \times 11 \times 5$. Use the "x" for the multiplication sign.

19) Assisment #49322 "49322 - Prime Factorization"

What is the prime factorization of 20?

Your answer should look like $11 \times 11 \times 5$. Use the "x" for the multiplication sign.

20) Assisment #49323 "49323 - Prime Factorization"

What is the prime factorization of 30?

Your answer should look like $11 \times 11 \times 5$. Use the "x" for the multiplication sign.

21) Assistment #49334 "49334 - Prime Factorization"

What is the prime factorization of 8?

Your answer should look like $11 \times 11 \times 5$. Use the "x" for the multiplication sign.

22) Assistment #49335 "49335 - Prime Factorization"

What is the prime factorization of 12?

Your answer should look like $11 \times 11 \times 5$. Use the "x" for the multiplication sign.

23) Assistment #49336 "49336 - Prime Factorization"

What is the prime factorization of 20?

Your answer should look like $11 \times 11 \times 5$. Use the "x" for the multiplication sign.

24) Assistment #49337 "49337 - Prime Factorization"

What is the prime factorization of 28?

Your answer should look like $11 \times 11 \times 5$. Use the "x" for the multiplication sign.

25) Assistment #49338 "49338 - Prime Factorization"

What is the prime factorization of 12?

Your answer should look like $11 \times 11 \times 5$. Use the "x" for the multiplication sign.

26) Assistment #49339 "49339 - Prime Factorization"

What is the prime factorization of 18?

Your answer should look like $11 \times 11 \times 5$. Use the "x" for the multiplication sign.

27) Assistment #49340 "49340 - Prime Factorization"

What is the prime factorization of 30?

Your answer should look like $11 \times 11 \times 5$. Use the "x" for the multiplication sign.

28) Assistment #49341 "49341 - Prime Factorization"

What is the prime factorization of 42?

Your answer should look like $11 \times 11 \times 5$. Use the "x" for the multiplication sign.

29) Assistment #49342 "49342 - Prime Factorization"

What is the prime factorization of 20?

Your answer should look like $11 \times 11 \times 5$. Use the "x" for the multiplication sign.

30) Assistment #49343 "49343 - Prime Factorization"

What is the prime factorization of 30?

Your answer should look like $11 \times 11 \times 5$. Use the "x" for the multiplication sign.

31) Assistment #49348 "49348 - Prime Factorization"

What is the prime factorization of 8?

Your answer should look like $11 \times 11 \times 5$. Use the "x" for the multiplication sign.

32) Assistment #49351 "49351 - Prime Factorization"

What is the prime factorization of 12?

Your answer should look like $11 \times 11 \times 5$. Use the "x" for the multiplication sign.

33) Assistment #49354 "49354 - Prime Factorization"

What is the prime factorization of 20?

Your answer should look like $11 \times 11 \times 5$. Use the "x" for the multiplication sign.

34) Assistment #49357 "49357 - Prime Factorization"

What is the prime factorization of 28?

Your answer should look like $11 \times 11 \times 5$. Use the "x" for the multiplication sign.

35) Assistment #49358 "49358 - Prime Factorization"

What is the prime factorization of 12?

Your answer should look like $11 \times 11 \times 5$. Use the "x" for the multiplication sign.

36) Assistment #49359 "49359 - Prime Factorization"

What is the prime factorization of 18?

Your answer should look like $11 \times 11 \times 5$. Use the "x" for the multiplication sign.

37) Assistment #49360 "49360 - Prime Factorization"

What is the prime factorization of 30?

Your answer should look like $11 \times 11 \times 5$. Use the "x" for the multiplication sign.

38) Assistment #49361 "49361 - Prime Factorization"

What is the prime factorization of 42?

Your answer should look like $11 \times 11 \times 5$. Use the "x" for the multiplication sign.

39) Assistment #49362 "49362 - Prime Factorization"

What is the prime factorization of 20?

Your answer should look like $11 \times 11 \times 5$. Use the "x" for the multiplication sign.

40) Assistment #49363 "49363 - Prime Factorization"

What is the prime factorization of 30?

Your answer should look like $11 \times 11 \times 5$. Use the "x" for the multiplication sign.

41) Assistment #49364 "49364 - Prime Factorization"

What is the prime factorization of 8?

Your answer should look like $11 \times 11 \times 5$. Use the "x" for the multiplication sign.

42) Assistment #49365 "49365 - Prime Factorization"

What is the prime factorization of 12?

Your answer should look like $11 \times 11 \times 5$. Use the "x" for the multiplication sign.

43) Assistment #49366 "49366 - Prime Factorization"

What is the prime factorization of 20?

Your answer should look like $11 \times 11 \times 5$. Use the "x" for the multiplication sign.

44) Assistment #49367 "49367 - Prime Factorization"

What is the prime factorization of 28?

Your answer should look like $11 \times 11 \times 5$. Use the "x" for the multiplication sign.

45) Assistment #49368 "49368 - Prime Factorization"

What is the prime factorization of 12?

Your answer should look like $11 \times 11 \times 5$. Use the "x" for the multiplication sign.

46) Assistment #49369 "49369 - Prime Factorization"

What is the prime factorization of 18?

Your answer should look like $11 \times 11 \times 5$. Use the "x" for the multiplication sign.

47) Assistment #49370 "49370 - Prime Factorization"

What is the prime factorization of 30?

Your answer should look like $11 \times 11 \times 5$. Use the "x" for the multiplication sign.

48) Assistment #49371 "49371 - Prime Factorization"

What is the prime factorization of 42?

Your answer should look like $11 \times 11 \times 5$. Use the "x" for the multiplication sign.

49) Assistment #49372 "49372 - Prime Factorization"

What is the prime factorization of 20?

Your answer should look like $11 \times 11 \times 5$. Use the "x" for the multiplication sign.

50) Assistment #49373 "49373 - Prime Factorization"

What is the prime factorization of 30?

Your answer should look like $11 \times 11 \times 5$. Use the "x" for the multiplication sign.

51) Assistment #49374 "49374 - Prime Factorization"

What is the prime factorization of 8?

Your answer should look like $11 \times 11 \times 5$. Use the "x" for the multiplication sign.

52) Assistment #49375 "49375 - Prime Factorization"

What is the prime factorization of 12?

Your answer should look like $11 \times 11 \times 5$. Use the "x" for the multiplication sign.

53) Assistment #49376 "49376 - Prime Factorization"

What is the prime factorization of 20?

Your answer should look like $11 \times 11 \times 5$. Use the "x" for the multiplication sign.

54) Assistment #49377 "49377 - Prime Factorization"

What is the prime factorization of 28?

Your answer should look like $11 \times 11 \times 5$. Use the "x" for the multiplication sign.

55) Assistment #49378 "49378 - Prime Factorization"

What is the prime factorization of 12?

Your answer should look like $11 \times 11 \times 5$. Use the "x" for the multiplication sign.

56) Assistment #49379 "49379 - Prime Factorization"

What is the prime factorization of 18?

Your answer should look like $11 \times 11 \times 5$. Use the "x" for the multiplication sign.

57) Assistment #49380 "49380 - Prime Factorization"

What is the prime factorization of 30?

Your answer should look like $11 \times 11 \times 5$. Use the "x" for the multiplication sign.

58) Assistment #49381 "49381 - Prime Factorization"

What is the prime factorization of 42?

Your answer should look like $11 \times 11 \times 5$. Use the "x" for the multiplication sign.

59) Assistment #49382 "49382 - Prime Factorization"

What is the prime factorization of 20?

Your answer should look like $11 \times 11 \times 5$. Use the "x" for the multiplication sign.

60) Assistment #49383 "49383 - Prime Factorization"

What is the prime factorization of 30?

Your answer should look like $11 \times 11 \times 5$. Use the "x" for the multiplication sign.

61) Assistment #49384 "49384 - Prime Factorization"

What is the prime factorization of 8?

Your answer should look like $11 \times 11 \times 5$. Use the "x" for the multiplication sign.

62) Assistment #49385 "49385 - Prime Factorization"

What is the prime factorization of 12?

Your answer should look like $11 \times 11 \times 5$. Use the "x" for the multiplication sign.

63) Assistment #49386 "49386 - Prime Factorization"

What is the prime factorization of 20?

Your answer should look like $11 \times 11 \times 5$. Use the "x" for the multiplication sign.

64) Assistment #49387 "49387 - Prime Factorization"

What is the prime factorization of 28?

Your answer should look like $11 \times 11 \times 5$. Use the "x" for the multiplication sign.

65) Assistment #49388 "49388 - Prime Factorization"

What is the prime factorization of 12?

Your answer should look like $11 \times 11 \times 5$. Use the "x" for the multiplication sign.

66) Assistment #49389 "49389 - Prime Factorization"

What is the prime factorization of 18?

Your answer should look like $11 \times 11 \times 5$. Use the "x" for the multiplication sign.

67) Assistment #49390 "49390 - Prime Factorization"

What is the prime factorization of 30?

Your answer should look like $11 \times 11 \times 5$. Use the "x" for the multiplication sign.

68) Assistment #49391 "49391 - Prime Factorization"

What is the prime factorization of 42?

Your answer should look like $11 \times 11 \times 5$. Use the "x" for the multiplication sign.

69) Assistment #49392 "49392 - Prime Factorization"

What is the prime factorization of 20?

Your answer should look like $11 \times 11 \times 5$. Use the "x" for the multiplication sign.

70) Assistment #49393 "49393 - Prime Factorization"

What is the prime factorization of 30?

Your answer should look like $11 \times 11 \times 5$. Use the "x" for the multiplication sign.

71) Assistment #49268 "49268 - Prime Factorization"

What is the prime factorization of 8?

Your answer should look like $11 \times 11 \times 5$. Use the "x" for the multiplication sign.

72) Assistment #49271 "49271 - Prime Factorization"

What is the prime factorization of 12?

Your answer should look like $11 \times 11 \times 5$. Use the "x" for the multiplication sign.

73) Assistment #49274 "49274 - Prime Factorization"

What is the prime factorization of 20?

Your answer should look like $11 \times 11 \times 5$. Use the "x" for the multiplication sign.

74) Assistment #49277 "49277 - Prime Factorization"

What is the prime factorization of 28?

Your answer should look like $11 \times 11 \times 5$. Use the "x" for the multiplication sign.

75) Assistment #49278 "49278 - Prime Factorization"

What is the prime factorization of 12?

Your answer should look like $11 \times 11 \times 5$. Use the "x" for the multiplication sign.

76) Assistment #49279 "49279 - Prime Factorization"

What is the prime factorization of 18?

Your answer should look like $11 \times 11 \times 5$. Use the "x" for the multiplication sign.

77) Assistment #49280 "49280 - Prime Factorization"

What is the prime factorization of 30?

Your answer should look like $11 \times 11 \times 5$. Use the "x" for the multiplication sign.

78) Assistment #49281 "49281 - Prime Factorization"

What is the prime factorization of 42?

Your answer should look like $11 \times 11 \times 5$. Use the "x" for the multiplication sign.

79) Assistment #49282 "49282 - Prime Factorization"

What is the prime factorization of 20?

Your answer should look like $11 \times 11 \times 5$. Use the "x" for the multiplication sign.

80) Assistment #49283 "49283 - Prime Factorization"

What is the prime factorization of 30?

Your answer should look like $11 \times 11 \times 5$. Use the "x" for the multiplication sign.

81) Assistment #49394 "49394 - Prime Factorization"

What is the prime factorization of 8?

Your answer should look like $11 \times 11 \times 5$. Use the "x" for the multiplication sign.

82) Assistment #49395 "49395 - Prime Factorization"

What is the prime factorization of 12?

Your answer should look like $11 \times 11 \times 5$. Use the "x" for the multiplication sign.

83) Assistment #49396 "49396 - Prime Factorization"

What is the prime factorization of 20?

Your answer should look like $11 \times 11 \times 5$. Use the "x" for the multiplication sign.

84) Assistment #49397 "49397 - Prime Factorization"

What is the prime factorization of 28?

Your answer should look like $11 \times 11 \times 5$. Use the "x" for the multiplication sign.

85) Assistment #49398 "49398 - Prime Factorization"

What is the prime factorization of 12?

Your answer should look like $11 \times 11 \times 5$. Use the "x" for the multiplication sign.

86) Assistment #49399 "49399 - Prime Factorization"

What is the prime factorization of 18?

Your answer should look like $11 \times 11 \times 5$. Use the "x" for the multiplication sign.

87) Assistment #49400 "49400 - Prime Factorization"

What is the prime factorization of 30?

Your answer should look like $11 \times 11 \times 5$. Use the "x" for the multiplication sign.

88) Assistment #49401 "49401 - Prime Factorization"

What is the prime factorization of 42?

Your answer should look like $11 \times 11 \times 5$. Use the "x" for the multiplication sign.

89) Assistment #49402 "49402 - Prime Factorization"

What is the prime factorization of 20?

Your answer should look like $11 \times 11 \times 5$. Use the "x" for the multiplication sign.

90) Assistment #49403 "49403 - Prime Factorization"

What is the prime factorization of 30?

Your answer should look like $11 \times 11 \times 5$. Use the "x" for the multiplication sign.

91) Assistment #52142 "52142 - Prime Factorization"

What is the prime factorization of 8?

Your answer should look like $11 \times 11 \times 5$. Use the "x" for the multiplication sign.

92) Assistment #52143 "52143 - Prime Factorization"

What is the prime factorization of 12?

Your answer should look like $11 \times 11 \times 5$. Use the "x" for the multiplication sign.

93) Assistment #52144 "52144 - Prime Factorization"

What is the prime factorization of 20?

Your answer should look like $11 \times 11 \times 5$. Use the "x" for the multiplication sign.

94) Assistment #52145 "52145 - Prime Factorization"

What is the prime factorization of 28?

Your answer should look like $11 \times 11 \times 5$. Use the "x" for the multiplication sign.

95) Assistment #52146 "52146 - Prime Factorization"

What is the prime factorization of 12?

Your answer should look like $11 \times 11 \times 5$. Use the "x" for the multiplication sign.

96) Assistment #52147 "52147 - Prime Factorization"

What is the prime factorization of 18?

Your answer should look like $11 \times 11 \times 5$. Use the "x" for the multiplication sign.

97) Assistment #52148 "52148 - Prime Factorization"

What is the prime factorization of 30?

Your answer should look like $11 \times 11 \times 5$. Use the "x" for the multiplication sign.

98) Assistment #52149 "52149 - Prime Factorization"

What is the prime factorization of 42?

Your answer should look like $11 \times 11 \times 5$. Use the "x" for the multiplication sign.

99) Assistment #52150 "52150 - Prime Factorization"

What is the prime factorization of 20?

Your answer should look like $11 \times 11 \times 5$. Use the "x" for the multiplication sign.

100) Assistment #52151 "52151 - Prime Factorization"

What is the prime factorization of 30?

Your answer should look like $11 \times 11 \times 5$. Use the "x" for the multiplication sign.

Problem Set 11893 "Scientific Notation - THE SKILL BUILDING SET" id:[11893]

1) Assistent #98944 "98944 - Converting from Standard Form to Scientific Notation"

The number 2,400,000 is written in standard form.
What is the number written in scientific notation?

Fill in the **blank**: $2.4 \times 10^{\underline{\quad?}}$

2) Assistent #98945 "98945 - Converting from Standard Form to Scientific Notation"

The number 130,000 is written in standard form.
What is the number written in scientific notation?

Fill in the **blank**: $1.3 \times 10^{\underline{\quad?}}$

3) Assistent #98946 "98946 - Converting from Standard Form to Scientific Notation"

The number 360,000 is written in standard form.
What is the number written in scientific notation?

Fill in the **blank**: $3.6 \times 10^{\underline{\quad?}}$

4) Assistent #98947 "98947 - Converting from Standard Form to Scientific Notation"

The number 130,000 is written in standard form.
What is the number written in scientific notation?

Fill in the **blank**: $1.3 \times 10^{\underline{\quad?}}$

5) Assistent #98948 "98948 - Converting from Standard Form to Scientific Notation"

The number 340,000,000 is written in standard form.
What is the number written in scientific notation?

Fill in the **blank**: $3.4 \times 10^{\underline{\quad?}}$

6) Assistent #98949 "98949 - Converting from Standard Form to Scientific Notation"

The number 360,000 is written in standard form.

What is the number written in scientific notation?

Fill in the **blank**: $3.6 \times 10^{\underline{\quad?}}$

7) Assistent #98950 "98950 - Converting from Standard Form to Scientific Notation"

The number 340,000,000 is written in standard form.

What is the number written in scientific notation?

Fill in the **blank**: $3.4 \times 10^{\underline{\quad?}}$

8) Assistent #98951 "98951 - Converting from Standard Form to Scientific Notation"

The number 430,000 is written in standard form.

What is the number written in scientific notation?

Fill in the **blank**: $4.3 \times 10^{\underline{\quad?}}$

9) Assistent #98952 "98952 - Converting from Standard Form to Scientific Notation"

The number 430,000 is written in standard form.

What is the number written in scientific notation?

Fill in the **blank**: $4.3 \times 10^{\underline{\quad?}}$

10) Assistent #98953 "98953 - Converting from Standard Form to Scientific Notation"

The number 2,400,000 is written in standard form.

What is the number written in scientific notation?

Fill in the **blank**: $2.4 \times 10^{\underline{\quad?}}$

11) Assistent #98954 "98954 - Converting from Standard Form to Scientific Notation"

The number 73,000 is written in standard form.

What is the number written in scientific notation?

Fill in the **blank**: $7.3 \times 10^{\underline{\quad?}}$

12) Assistent #98955 "98955 - Converting from Standard Form to Scientific Notation"

The number 73,000 is written in standard form.

What is the number written in scientific notation?

Fill in the **blank**: $7.3 \times 10^{\underline{\quad?}}$

13) Assistent #98956 "98956 - Converting from Standard Form to Scientific Notation"

The number 9,000 is written in standard form.
What is the number written in scientific notation?

Fill in the **blank**: $9 \times 10^{\underline{\quad?}}$

14) Assistent #98957 "98957 - Converting from Standard Form to Scientific Notation"

The number 430,000 is written in standard form.
What is the number written in scientific notation?

Fill in the **blank**: $4.3 \times 10^{\underline{\quad?}}$

15) Assistent #98958 "98958 - Converting from Standard Form to Scientific Notation"

The number 430,000 is written in standard form.
What is the number written in scientific notation?

Fill in the **blank**: $4.3 \times 10^{\underline{\quad?}}$

16) Assistent #98959 "98959 - Converting from Standard Form to Scientific Notation"

The number 65,000 is written in standard form.
What is the number written in scientific notation?

Fill in the **blank**: $6.5 \times 10^{\underline{\quad?}}$

17) Assistent #98960 "98960 - Converting from Standard Form to Scientific Notation"

The number 360,000 is written in standard form.
What is the number written in scientific notation?

Fill in the **blank**: $3.6 \times 10^{\underline{\quad?}}$

18) Assistent #98961 "98961 - Converting from Standard Form to Scientific Notation"

The number 73,000 is written in standard form.
What is the number written in scientific notation?

Fill in the **blank**: $7.3 \times 10^{\underline{\quad?}}$

19) Assistent #98962 "98962 - Converting from Standard Form to Scientific Notation"

The number 360,000 is written in standard form.
What is the number written in scientific notation?

Fill in the **blank**: $3.6 \times 10^{\underline{\quad?}}$

20) Assistent #98963 "98963 - Converting from Standard Form to Scientific Notation"

The number 360,000 is written in standard form.
What is the number written in scientific notation?

Fill in the **blank**: $3.6 \times 10^{\underline{\quad?}}$

21) Assistent #98964 "98964 - Converting from Standard Form to Scientific Notation"

The number 96,000 is written in standard form.
What is the number written in scientific notation?

Fill in the **blank**: $9.6 \times 10^{\underline{\quad?}}$

22) Assistent #98965 "98965 - Converting from Standard Form to Scientific Notation"

The number 9,000 is written in standard form.
What is the number written in scientific notation?

Fill in the **blank**: $9 \times 10^{\underline{\quad?}}$

23) Assistent #98966 "98966 - Converting from Standard Form to Scientific Notation"

The number 73,000 is written in standard form.
What is the number written in scientific notation?

Fill in the **blank**: $7.3 \times 10^{\underline{\quad?}}$

24) Assistent #98967 "98967 - Converting from Standard Form to Scientific Notation"

The number 930,000 is written in standard form.
What is the number written in scientific notation?

Fill in the **blank**: $9.3 \times 10^{\underline{\quad?}}$

25) Assistent #98968 "98968 - Converting from Standard Form to Scientific Notation"

The number 930,000 is written in standard form.
What is the number written in scientific notation?

Fill in the **blank**: $9.3 \times 10^{\underline{\quad?}}$

26) Assistent #98969 "98969 - Converting from Standard Form to Scientific Notation"

The number 74,000 is written in standard form.
What is the number written in scientific notation?

$\underline{\quad?}$

Fill in the **blank**: 7.4×10

27) Assistent #98970 "98970 - Converting from Standard Form to Scientific Notation"

The number 2,400,000 is written in standard form.
What is the number written in scientific notation?

Fill in the **blank**: 2.4×10 ?

28) Assistent #98971 "98971 - Converting from Standard Form to Scientific Notation"

The number 9,000 is written in standard form.
What is the number written in scientific notation?

Fill in the **blank**: 9×10 ?

29) Assistent #98972 "98972 - Converting from Standard Form to Scientific Notation"

The number 74,000 is written in standard form.
What is the number written in scientific notation?

Fill in the **blank**: 7.4×10 ?

30) Assistent #98973 "98973 - Converting from Standard Form to Scientific Notation"

The number 340,000,000 is written in standard form.
What is the number written in scientific notation?

Fill in the **blank**: 3.4×10 ?

31) Assistent #98974 "98974 - Converting from Standard Form to Scientific Notation"

The number 360,000 is written in standard form.
What is the number written in scientific notation?

Fill in the **blank**: 3.6×10 ?

32) Assistent #98975 "98975 - Converting from Standard Form to Scientific Notation"

The number 930,000 is written in standard form.
What is the number written in scientific notation?

Fill in the **blank**: 9.3×10 ?

33) Assistent #98976 "98976 - Converting from Standard Form to Scientific Notation"

The number 96,000 is written in standard form.

What is the number written in scientific notation?

Fill in the **blank**: $9.6 \times 10^{\underline{\quad?}}$

34) Assistment #98977 "98977 - Converting from Standard Form to Scientific Notation"

The number 74,000 is written in standard form.
What is the number written in scientific notation?

Fill in the **blank**: $7.4 \times 10^{\underline{\quad?}}$

35) Assistment #98978 "98978 - Converting from Standard Form to Scientific Notation"

The number 96,000 is written in standard form.
What is the number written in scientific notation?

Fill in the **blank**: $9.6 \times 10^{\underline{\quad?}}$

36) Assistment #98979 "98979 - Converting from Standard Form to Scientific Notation"

The number 74,000 is written in standard form.
What is the number written in scientific notation?

Fill in the **blank**: $7.4 \times 10^{\underline{\quad?}}$

37) Assistment #98980 "98980 - Converting from Standard Form to Scientific Notation"

The number 65,000 is written in standard form.
What is the number written in scientific notation?

Fill in the **blank**: $6.5 \times 10^{\underline{\quad?}}$

38) Assistment #98981 "98981 - Converting from Standard Form to Scientific Notation"

The number 9,000 is written in standard form.
What is the number written in scientific notation?

Fill in the **blank**: $9 \times 10^{\underline{\quad?}}$

39) Assistment #98982 "98982 - Converting from Standard Form to Scientific Notation"

The number 430,000 is written in standard form.
What is the number written in scientific notation?

Fill in the **blank**: $4.3 \times 10^{\underline{\quad?}}$

40) Assistment #98983 "98983 - Converting from Standard Form to Scientific Notation"

The number 340,000,000 is written in standard form.
What is the number written in scientific notation?

Fill in the **blank**: $3.4 \times 10^{\underline{\quad?}}$

41) Assistment #98984 "98984 - Converting from Standard Form to Scientific Notation"

The number 930,000 is written in standard form.
What is the number written in scientific notation?

Fill in the **blank**: $9.3 \times 10^{\underline{\quad?}}$

42) Assistment #98985 "98985 - Converting from Standard Form to Scientific Notation"

The number 130,000 is written in standard form.
What is the number written in scientific notation?

Fill in the **blank**: $1.3 \times 10^{\underline{\quad?}}$

43) Assistment #98986 "98986 - Converting from Standard Form to Scientific Notation"

The number 65,000 is written in standard form.
What is the number written in scientific notation?

Fill in the **blank**: $6.5 \times 10^{\underline{\quad?}}$

44) Assistment #98987 "98987 - Converting from Standard Form to Scientific Notation"

The number 9,700,000,000 is written in standard form.
What is the number written in scientific notation?

Fill in the **blank**: $9.7 \times 10^{\underline{\quad?}}$

45) Assistment #98988 "98988 - Converting from Standard Form to Scientific Notation"

The number 65,000 is written in standard form.
What is the number written in scientific notation?

Fill in the **blank**: $6.5 \times 10^{\underline{\quad?}}$

46) Assistment #98989 "98989 - Converting from Standard Form to Scientific Notation"

The number 74,000 is written in standard form.
What is the number written in scientific notation?

Fill in the **blank**: $7.4 \times 10^{\underline{\quad?}}$

47) Assistment #98990 "98990 - Converting from Standard Form to Scientific Notation"

The number 96,000 is written in standard form.
What is the number written in scientific notation?

Fill in the **blank**: $9.6 \times 10^{\underline{\quad?}}$

48) Assistment #98991 "98991 - Converting from Standard Form to Scientific Notation"

The number 130,000 is written in standard form.
What is the number written in scientific notation?

Fill in the **blank**: $1.3 \times 10^{\underline{\quad?}}$

49) Assistment #98992 "98992 - Converting from Standard Form to Scientific Notation"

The number 73,000 is written in standard form.
What is the number written in scientific notation?

Fill in the **blank**: $7.3 \times 10^{\underline{\quad?}}$

50) Assistment #98993 "98993 - Converting from Standard Form to Scientific Notation"

The number 73,000 is written in standard form.
What is the number written in scientific notation?

Fill in the **blank**: $7.3 \times 10^{\underline{\quad?}}$

51) Assistment #113539 "113539 - 46036 - Converting from Scientific Notation to Standard Notation"

The number below is written in scientific notation.

$$4.23 \times 10^6$$

Write the number in standard notation.

52) Assistment #113540 "113540 - 46036 - Converting from Scientific Notation to Standard Notation"

The number below is written in scientific notation.

$$2.10 \times 10^6$$

Write the number in standard notation.

53) Assistment #113541 "113541 - 46036 - Converting from Scientific Notation to Standard Notation"

The number below is written in scientific notation.

$$1.65 \times 10^4$$

Write the number in standard notation.

54) Assistment #113542 "113542 - 46036 - Converting from Scientific Notation to Standard Notation"

The number below is written in scientific notation.

$$3.36 \times 10^3$$

Write the number in standard notation.

55) Assistment #113543 "113543 - 46036 - Converting from Scientific Notation to Standard Notation"

The number below is written in scientific notation.

$$2.12 \times 10^4$$

Write the number in standard notation.

56) Assistment #113544 "113544 - 46036 - Converting from Scientific Notation to Standard Notation"

The number below is written in scientific notation.

$$8.78 \times 10^4$$

Write the number in standard notation.

57) Assistment #113545 "113545 - 46036 - Converting from Scientific Notation to Standard Notation"

The number below is written in scientific notation.

$$2.60 \times 10^9$$

Write the number in standard notation.

58) Assistment #113546 "113546 - 46036 - Converting from Scientific Notation to Standard Notation"

The number below is written in scientific notation.

$$3.65 \times 10^9$$

Write the number in standard notation.

59) Assistment #113547 "113547 - 46036 - Converting from Scientific Notation to Standard Notation"

The number below is written in scientific notation.

$$2.38 \times 10^8$$

Write the number in standard notation.

60) Assistment #113548 "113548 - 46036 - Converting from Scientific Notation to Standard Notation"

The number below is written in scientific notation.

$$1.62 \times 10^4$$

Write the number in standard notation.

61) Assistment #113549 "113549 - 46036 - Converting from Scientific Notation to Standard Notation"

The number below is written in scientific notation.

$$8.64 \times 10^5$$

Write the number in standard notation.

62) Assistment #113550 "113550 - 46036 - Converting from Scientific Notation to Standard Notation"

The number below is written in scientific notation.

$$4.2 \times 10^8$$

Write the number in standard notation.

63) Assistment #113551 "113551 - 46036 - Converting from Scientific Notation to Standard Notation"

The number below is written in scientific notation.

$$1.82 \times 10^3$$

Write the number in standard notation.

64) Assistment #113552 "113552 - 46036 - Converting from Scientific Notation to Standard Notation"

The number below is written in scientific notation.

$$8.83 \times 10^5$$

Write the number in standard notation.

65) Assistment #113553 "113553 - 46036 - Converting from Scientific Notation to Standard Notation"

The number below is written in scientific notation.

$$5.13 \times 10^4$$

Write the number in standard notation.

66) Assistment #113554 "113554 - 46036 - Converting from Scientific Notation to Standard Notation"

The number below is written in scientific notation.

$$6.95 \times 10^4$$

Write the number in standard notation.

67) Assistment #113555 "113555 - 46036 - Converting from Scientific Notation to Standard Notation"

The number below is written in scientific notation.

$$8.3 \times 10^9$$

Write the number in standard notation.

68) Assistment #113556 "113556 - 46036 - Converting from Scientific Notation to Standard Notation"

The number below is written in scientific notation.

$$3.69 \times 10^6$$

Write the number in standard notation.

69) Assistment #113557 "113557 - 46036 - Converting from Scientific Notation to Standard Notation"

The number below is written in scientific notation.

$$6.52 \times 10^5$$

Write the number in standard notation.

70) Assistment #113558 "113558 - 46036 - Converting from Scientific Notation to Standard Notation"

The number below is written in scientific notation.

$$6.97 \times 10^7$$

Write the number in standard notation.

71) Assistment #113559 "113559 - 46036 - Converting from Scientific Notation to Standard Notation"

The number below is written in scientific notation.

$$7.91 \times 10^4$$

Write the number in standard notation.

72) Assistment #113560 "113560 - 46036 - Converting from Scientific Notation to Standard Notation"

The number below is written in scientific notation.

$$4.1 \times 10^9$$

Write the number in standard notation.

73) Assistment #113561 "113561 - 46036 - Converting from Scientific Notation to Standard Notation"

The number below is written in scientific notation.

$$2.90 \times 10^9$$

Write the number in standard notation.

74) Assistment #113562 "113562 - 46036 - Converting from Scientific Notation to Standard Notation"

The number below is written in scientific notation.

$$5.71 \times 10^8$$

Write the number in standard notation.

75) Assistment #113563 "113563 - 46036 - Converting from Scientific Notation to Standard Notation"

The number below is written in scientific notation.

$$8.16 \times 10^4$$

Write the number in standard notation.

76) Assistment #113564 "113564 - 46036 - Converting from Scientific Notation to Standard Notation"

The number below is written in scientific notation.

$$5.53 \times 10^8$$

Write the number in standard notation.

77) Assistment #113565 "113565 - 46036 - Converting from Scientific Notation to Standard Notation"

The number below is written in scientific notation.

$$3.94 \times 10^6$$

Write the number in standard notation.

78) Assistment #113566 "113566 - 46036 - Converting from Scientific Notation to Standard Notation"

The number below is written in scientific notation.

$$7.17 \times 10^3$$

Write the number in standard notation.

79) Assistment #113567 "113567 - 46036 - Converting from Scientific Notation to Standard Notation"

The number below is written in scientific notation.

$$6.80 \times 10^6$$

Write the number in standard notation.

80) Assistment #113568 "113568 - 46036 - Converting from Scientific Notation to Standard Notation"

The number below is written in scientific notation.

$$6.22 \times 10^7$$

Write the number in standard notation.

81) Assistment #113569 "113569 - 46036 - Converting from Scientific Notation to Standard Notation"

The number below is written in scientific notation.

$$3.71 \times 10^7$$

Write the number in standard notation.

82) Assistment #113570 "113570 - 46036 - Converting from Scientific Notation to Standard Notation"

The number below is written in scientific notation.

$$3.34 \times 10^7$$

Write the number in standard notation.

83) Assistment #113571 "113571 - 46036 - Converting from Scientific Notation to Standard Notation"

The number below is written in scientific notation.

$$2.89 \times 10^5$$

Write the number in standard notation.

84) Assistment #113572 "113572 - 46036 - Converting from Scientific Notation to Standard Notation"

The number below is written in scientific notation.

$$3.91 \times 10^7$$

Write the number in standard notation.

85) Assistment #113573 "113573 - 46036 - Converting from Scientific Notation to Standard Notation"

The number below is written in scientific notation.

$$8.38 \times 10^9$$

Write the number in standard notation.

86) Assistment #113574 "113574 - 46036 - Converting from Scientific Notation to Standard Notation"

The number below is written in scientific notation.

$$2.22 \times 10^4$$

Write the number in standard notation.

87) Assistment #113575 "113575 - 46036 - Converting from Scientific Notation to Standard Notation"

The number below is written in scientific notation.

$$4.52 \times 10^4$$

Write the number in standard notation.

88) Assistment #113576 "113576 - 46036 - Converting from Scientific Notation to Standard Notation"

The number below is written in scientific notation.

$$6.5 \times 10^5$$

Write the number in standard notation.

89) Assistment #113577 "113577 - 46036 - Converting from Scientific Notation to Standard Notation"

The number below is written in scientific notation.

$$2.97 \times 10^3$$

Write the number in standard notation.

90) Assistment #113578 "113578 - 46036 - Converting from Scientific Notation to Standard Notation"

The number below is written in scientific notation.

$$1.35 \times 10^3$$

Write the number in standard notation.

91) Assistment #113579 "113579 - 46036 - Converting from Scientific Notation to Standard Notation"

The number below is written in scientific notation.

$$7.48 \times 10^5$$

Write the number in standard notation.

92) Assistment #113580 "113580 - 46036 - Converting from Scientific Notation to Standard Notation"

The number below is written in scientific notation.

$$7.16 \times 10^8$$

Write the number in standard notation.

93) Assistment #113581 "113581 - 46036 - Converting from Scientific Notation to Standard Notation"

The number below is written in scientific notation.

$$6.80 \times 10^4$$

Write the number in standard notation.

94) Assistment #113582 "113582 - 46036 - Converting from Scientific Notation to Standard Notation"

The number below is written in scientific notation.

$$6.87 \times 10^5$$

Write the number in standard notation.

95) Assistment #113583 "113583 - 46036 - Converting from Scientific Notation to Standard Notation"

The number below is written in scientific notation.

$$6.14 \times 10^9$$

Write the number in standard notation.

96) Assistment #113584 "113584 - 46036 - Converting from Scientific Notation to Standard Notation"

The number below is written in scientific notation.

$$2.8 \times 10^3$$

Write the number in standard notation.

97) Assistment #113585 "113585 - 46036 - Converting from Scientific Notation to Standard Notation"

The number below is written in scientific notation.

$$6.27 \times 10^6$$

Write the number in standard notation.

98) Assistment #113586 "113586 - 46036 - Converting from Scientific Notation to Standard Notation"

The number below is written in scientific notation.

$$7.96 \times 10^9$$

Write the number in standard notation.

99) Assistment #113587 "113587 - 46036 - Converting from Scientific Notation to Standard Notation"

The number below is written in scientific notation.

$$4.25 \times 10^5$$

Write the number in standard notation.

100) Assistment #113588 "113588 - 46036 - Converting from Scientific Notation to Standard Notation"

The number below is written in scientific notation.

$$3.9 \times 10^4$$

Write the number in standard notation.

Problem Set "Post Test A" id:[29750]

1) Assistent #91925 "91925 - 55956 – Area of Circle"

What is the **diameter** of the circle when the area of the circle is **78.5**? (use 3.14 for π)

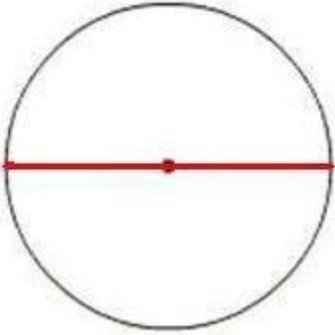

image not to scale

2) Assistent #125913 "125913 - Proportions"

A town is planning to build a $\frac{2}{5}$ scale replica of St. Peter's Basilica, a church in Rome. A blueprint of the replica represents 6 ft as 1 inch. If the height of the replica basilica on the blueprint is 30 inches, what is the height of the original basilica in Rome?

3) Assistent #47785 "47785 - Scale"

A map has a scale of 3 in. = 12 mi. If you measured the distance between two cities to be 20 in. on the map, how many miles would it actually be?

If necessary, round your answer to the nearest tenth.

4) Assistent #98411 "98411 - Division: Fractions"

Q 4/14

Page 21 #26

(You have 3 attempts. Do not press 'Break this problem into steps' button, otherwise you will lose one of your chances.)

5) Assistentment #119153 "119153 - 113484 - Solving Variable Equation"

Give the value of 'a' in terms of 'b' from the following expression:

$$2(8a + 5b) = -12$$

So fill in the blank for

$$a = \underline{\hspace{2cm}}$$

6) Assistentment #47330 "47330 - Converting Decimals to Fractions "

Convert 0.4 into a **fraction**. You must simplify your answer to lowest terms.

7) Assistentment #48279 "48279 - Multiplying Fractions with Mixed Numbers"

What is the product of $1 \frac{1}{2}$ x $\frac{1}{2}$?

You **MUST** reduce your answer to lowest terms.

If your answer is a mixed number, be sure to put a space between the whole number and the fraction in your answer. The answer should look like this: $6 \frac{2}{3}$. Not like this: $62/3$

8) Assistentment #92253 "92253 - 75986 - 75681 - 75679 - 75489 - 58264 - Perimeter of the Polygons"

What is the perimeter of the follwing object with the given information?

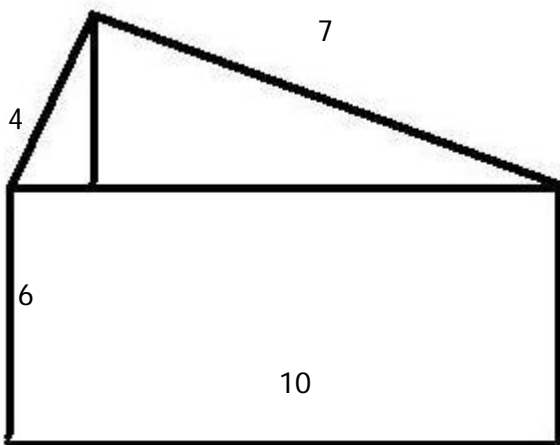

image not to scale

9) Assistent #34310 "34310 – Absolute Value"

What is the value of the expression below?

$$|7| + |-16|$$

10) Assistent #47010 "47010 - 27970 - 7th Grade: Accentuate the Negative – Absolute Value"

What is the value of the expression below?

$$|-17| - |-12|$$

11) Assistent #46785 "46785 - 45804 - Order of Operations"

$$2 \cdot 2 + 2^2$$

12) Assistent #38050 "38050 - Fraction Conversion"

Convert $\frac{12}{3}$ into a **percent**.

(round to the nearest percent)

13) Assistent #97684 "97684 - Adding Fractions"

What is the sum of $\frac{1}{6} + \frac{3}{7}$?

14) Assistent #48389 "48389 – Equivalent Fractions"

Find the value of **b** that makes the fraction equivalent.

$$\frac{\mathbf{b}}{36} = \frac{13}{9}$$

15) Assistent #91966 "91966 - 65824- Area of Irregular Figures"

What is the area of the shaded region in the figure below? (Use 3.14 for π)

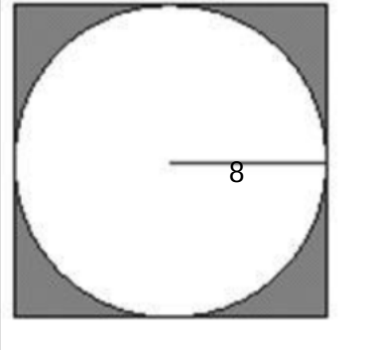

image not to scale

16) Assistent #46769 "46769 – Discount and Sales Tax"

If a new basketball is labeled \$20, what would the **new price** be if the sign above it says "16% off"?

Round your answer to the nearest Cent.

17) Assistent #69451 "69451 - Substitution"

If x is equal to 16 and y is equal to 14
then what is the value of $x + 12y$?

18) Assistent #87197 "87197 – Equation Solving for one variable"

Solve for x .
 $6(7x - 10x) = -3$

Answer as a fraction.

19) Assistent #87222 "87222 – Equation Solving for one variable (transfer)"

Solve for x .
 $11(8 + x) = 9(5 + x)$

Answer as a fraction.

1) Assistent #47551 "47551 - Least Common Multiple"

What is the **least common multiple** of 9 and 6?

2) Assistent #115432 "115432 - Composition of Funtions – Addition"

Carl has a rule for calculating how many jumping jacks he must do from Monday morning to Friday night (WD - Weekdays) and how many jumping jacks he must do From Saturday morning to Sunday night (WE - Weekend). His rules depend on the number of slices of pizza (x) he eats.

$$WD = 8x^2 + 8x + 8$$

$$WE = 1x + 5$$

Write an equation for the number of crunches he does in a week.

Fill in the blank ONE WEEK = _____

3) Assistent #118053 "118053 - Composition of Functions – Substitution"

Suppose you have:

$$g = 4z + 14$$

$$z = 4x - 4x^2$$

What is g in terms of x?

4) Assistent #109812 "109812 - Recognizing Equivalent Expressions"

If the following two expressions are equivalent or not:

1. $3(6x + 1) + 42 + (-2x)$

2. $13x + 45$

Yes, the two expressions are equivalent

No, the two expressions are not equivalent

5) Assistent #111334 "111334 - Definition: Distributive, Associative, Commutative"

Here is one way you might prove that $22 + 5(6x + 9) + 19x$ is equivalent to $49x + 67$

1. $5(6x + 9) + 22 + 19x$

2. $= 30x + 45 + 22 + 19x$
3. $= 30x + 19x + 45 + 22$
4. $= (30 + 19)x + 45 + 22$
5. $= 49x + 67$

What properties of numbers and operations justify the step from the green line to the orange line (from step 2 to step 3)?

Distributive Property

Addition

Associative Property

Commutative Property

6) Assistent #99328 "99328 - Multiplication - Integers: Negative times Negative"

What is $(-5) \cdot (-2)$?

7) Assistent #63862 "63862 - 57624 - Divisibility by 6"

Which number is divisible by 6?

150

151

68

57

166

8) Assistent #125908 "125908 – Least Common Multiple"

You are at the store buying hot dogs and buns for a barbecue. However, you find that the hot dogs only come in packages of 6, while the hot dogs come in packages of 8. If you buy an equal amount of hot dogs and buns, what is the least possible number of hot dogs you will have bought for the barbecue?

9) Assistent #49321 "49321 - Prime Factorization"

What is the prime factorization of 42?

Your answer should look like $11 \times 11 \times 5$. Use the "x" for the multiplication sign.

10) Assistent #121223 "121223 – Writing Equation from Situation"

Anthony is in a row boat on a lake. He is 753 yards from the dock. He then rows for m minutes back toward the dock. Anthony rows at a speed of 58 yards per minute. Write an expression for Anthony's distance from the dock dependent on the number of minutes he has rowed.

11) Assistent #40719 "40719 - Percent of"

What is 160% of 50?

12) Assistent #34571 "34571 - Addition - Decimals: carry over of tenths"

What is $4.4 + -3.9$?

13) Assistent #119432 "119432 – Writing Equation from Diagram"

If the diameter of the can is $4x$, find the expression for the total surface area of the can. This includes the top and bottom of the can, as well as the label area.

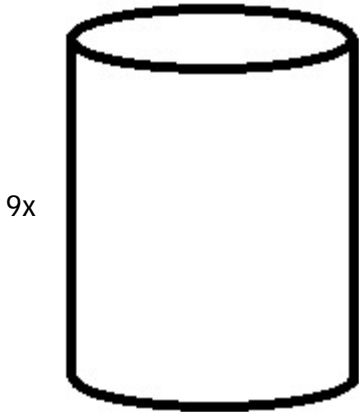

Type π in as "pi" and put any fractions in parentheses.

Ex. $4x^2 + (9/5)x^2\pi + 6x$

14) Assistent #48742 "48742 - Greatest Common Factor"

Find the greatest common factor for 45 and 30.

15) Assistent #85621 "85621 - Simplifying Expressions with Distributive, Combining Terms, and Exponents"

Use the distributive property to multiply.

$$-10(8x + 6y + 3)$$

Type your answers without any spaces and in standard form.

Standard Form: $3x - 2y + z + 5$. Make sure to write $3 + -5$ as $3 - 5$

16) Assistent #98980 "98980 - Converting from Standard Form to Scientific Notation"

The number 65,000 is written in standard form.

What is the number written in scientific notation?

Fill in the blank: $6.5 \times 10^{\underline{\quad?}}$