

# *Bose IR Reception Test Improvements*

---

Submitted to the Faculty of

WORCESTER POLYTECHNIC INSTITUTE

In partial fulfilment of the requirements for this

Major Qualifying Project

By:

---

Justin Brousseau, ME

---

Connor MacMillan, ME

---

Michael Roche, ME

Date: March 25, 2016

Approved By:

---

Professor David C. Planchard, ME Advisor

## Abstract

Bose Corporation uses infrared technology (IR) in a variety of commercially available products. With such a reliance on IR, the effective evaluation of product performance is crucial from a product development and marketing perspective. This project focused on the development of a robust, quantitative and repeatable testing procedure with which Bose Corporation could qualify their infrared technology. Specific areas of focus include the design and implementation of a standard test procedure and test fixtures that increase test precision, reduced human error in the test, and decrease test time. With a more universal and defined testing procedure, the comparison of different products becomes more effective, and measurement variation between test operators and products is reduced by 50%. Through this decrease in variation, the need for cross-functional meetings that are currently held throughout the development of a product will be eliminated and the overall testing process will be reduced to 1/4 the time of the current process.

## Executive Summary

Bose uses infrared technology in many of their products across their home entertainment division. Even though using infrared (IR) is a common practice in the market, there are no quantitative performance standards for IR currently in industry. As a result, Bose created an in-house test procedure as a way to qualify their remotes. However, since there are no set industry standards, the large test variations and significant testing time has forced teams to make subjective determinations as to what is a good product.

This project was to create a robust, quantitative, and repeatable testing procedure from which Bose can accurately qualify their IR products. To do this, the team looked at the current Bose technology, specifically the CineMate universal remote and CineMate 520 console, and analyzed the existing testing and calibration procedure. With this information, the team then created a testing process that was more repeatable and with a reduced testing time.

In their current state, Bose uses a test created by one of their employees. Due to space constraints, the test needed a method for simulating distance between the remote and console in confined spaces. This was done by reducing the current to the IR LED in the remote. Decreasing output power simulates the remote operating at a greater distance. This procedure resulted in the development of a distance factor (DF).

The next step was to have a consistent method of finding the equation that relates the simulated distance to the actual distance that can be expected to work. This is done through preliminary testing and relating the actual maximum effective distance to the simulated distance. This distance factor is then used during the test that qualifies the product system.

Utilizing this distance factor, and taking into account different areas of variation that existed in the Bose test, the final testing procedure consists of a fixed distance between the products and varying the output power. Fixing the distance between the remote and console eliminates the inherent variation that exists when moving the fixtures and re-measuring the distance between them. This also ensures that the remote is always properly oriented to point at the center of the console. The console itself is rotated to simulate different angles of use, as opposed to moving the remote in an arc. This again allows for more confidence in the relative angle between the remote and console, and it also removes the need to constantly re-measure the system.

With the test created by the project team, the data collected from the test illustrates a detailed map of how far away from the remote the console can successfully receive commands. Moving forward, this information will allow Bose to both see areas of improvement and compare market products more effectively.

In the interest of reducing measurement variability and creating a faster testing time, the team began making two fixtures to simplify the process as much as possible. The two fixtures included a Console Fixture and a Remote Fixture.

The Console Fixture utilized two degrees of freedom to rotate the console both horizontally and vertically. This was done using two DC Gear Motors that were attached to gear mechanisms. If automated properly this could give rise to a very fast and accurate process.

The Remote Fixture has a remote control on one side of it and an IR transmitter on the other. The remote is used as it normally would be and the IR blaster uses an Arduino to command it to send particular signals to qualify the console.

## Table of Contents

Abstract.....	2
Executive Summary.....	3
List of Figures .....	7
List of Tables .....	9
List of Equations.....	9
List of Symbols.....	10
Overview of Bose Corporation IR Reception Testing.....	11
Infrared Transmitter and Receiver Research .....	12
Dissecting Bose’s Infrared Remotes.....	13
Testing the Remote’s Signal Output with an Oscilloscope .....	16
Dissecting the Bose Cinemate® 520 Console.....	17
Bose’s Current Process.....	18
Simulating Distance.....	21
Specifications of the Transmitter.....	21
Theoretical Distance Factor .....	22
Experimental Distance Factor .....	23
Modifying the Remote .....	23
Running the Experiment .....	25
Comparing Results .....	28
Variability in the Test Process.....	29
Test Set-Up.....	29
Environment .....	30
Test Operator .....	31
Determining Elements of the Procedure .....	31
Changing the Relative Angle .....	32
Varying Relative Distance .....	32
Output Data .....	33
Narrowing to Two Procedures .....	33
Concept 1: Fixed Distance & Fixed Resistance.....	34
Concept 2: Fixing Distance & Varying Resistance .....	34
Sample Test Results .....	35

Final Procedures.....	36
Creating Testing Equipment.....	38
Design Specifications .....	38
Morphological Chart .....	39
Design Iteration 1.....	39
Design Iteration 2.....	40
Vertical Motion .....	40
Horizontal Motion.....	41
Prototyping .....	43
Determining Electronics.....	45
Using a Potentiometer .....	46
Design Iteration 3.....	46
Vertical Motion .....	46
Horizontal Motion.....	47
Motor Selection .....	49
Prototyping .....	50
Calculations.....	54
Prototype of Remote Fixture .....	58
Qualification of Fixture .....	60
Recommendations .....	61
Appendix .....	63
Appendix A.....	63
Appendix B.....	65
Appendix C .....	66
Appendix D.....	73
Appendix E .....	74
Appendix F .....	78
Appendix G.....	82

## List of Figures

Figure 1: IR Transmitter / Receiver Circuit.....	12
Figure 2: Standard IR Signal .....	12
Figure 3: IR Transmitter Signal .....	13
Figure 4: Bose Universal Infrared Remote .....	13
Figure 5: Bose Remote Button Pad, Top .....	14
Figure 6: Bose Remote Button Pad, Bottom .....	14
Figure 7: Circuit Break in CIRCUIT BOARD .....	14
Figure 8: Bose Remote Infrared Subassembly .....	15
Figure 9: Bose Remote Power Input .....	15
Figure 10: Bose Remote Connected to Oscilloscope and DC Power Supply.....	16
Figure 11: Bose Remote On/Off Signal Output.....	16
Figure 12: Bose Cinemate® 520 .....	17
Figure 13: Breakdown of Bose Cinemate® Circuit Board.....	17
Figure 14: Close-Up of IR Receivers .....	18
Figure 15: Internal View of the Light pipe and IR Receiver.....	18
Figure 16: Bose's Switch Board .....	19
Figure 17: Bose Current Test Setup .....	19
Figure 18: Relative Radiant Intensity vs. Forward Current .....	22
Figure 19: Radiant Diagram .....	22
Figure 20: Wires Soldered into Power Supply .....	24
Figure 21: Wires Soldered in Place of R2 .....	24
Figure 22: R2 Replaced with 1000Ω Potentiometer .....	24
Figure 23: Remote Using Consistent Power Supply and Potentiometer .....	25
Figure 24: Set Up of Distance Factor Experiment .....	25
Figure 25: Distance vs Resistance of Remote 1 R2 .....	26
Figure 26: Distance vs Resistance of R2 in Remote 1 Semi Log Plot.....	27
Figure 27: Comparing Distance Factors .....	28
Figure 28: Fishbone Diagram .....	29
Figure 29: Horizontal Angle.....	30
Figure 30: Vertical Angle .....	30
Figure 31: Design Iteration 1.....	39
Figure 32: Rack and Pinion Mechanism .....	40
Figure 33: Isometric View of Fixture .....	40
Figure 34: Sliding Carriage Subassembly .....	41
Figure 35: Horizontal Motion Bevel Gears.....	42
Figure 36: Modified Assembly for Rack and Pinion .....	43
Figure 37: Potentiometer and Pinion.....	44
Figure 38: 3D Printed Bevel Gears .....	45
Figure 39: Vertical Gear .....	46
Figure 40: Side View of Fixture Assembly.....	47

Figure 41: Horizontal Motion Gear System ..... 48  
Figure 42: Top View of Fixture Assembly ..... 49  
Figure 43: 12 Volt DC Motor with Encoder ..... 50  
Figure 44: Housing Box ..... 51  
Figure 45: Laser Cut Gears ..... 51  
Figure 46: Console Fixture Prototype 3 ..... 52  
Figure 47: Fixture Holding Console ..... 52  
Figure 48: Remote and IR Blaster Fixture ..... 58  
*Figure 49: Remote and IR Blaster Fixture Side View* ..... 59  
Figure 50: Remote and IR Blaster Prototype ..... 59



## List of Tables

Table 1: R2 Measurements .....	15
Table 2: Bose's Distance Factor Calculations .....	20
Table 3: Max Resistance at Set Distance.....	26
Table 4: Morphological Chart of Possible Testing Processes.....	32
Table 5: Weighted Decision Matrix.....	33
Table 6: Fixed Distance Fixed Resistance Results .....	35
Table 7: Fixed Distance Varying Resistance Results.....	36
Table 8: Baseline Reception Test Template .....	37
Table 9: Expected Maximum Distance Template .....	37
Table 10: Console Fixture Morphological Chart .....	39
Table 11: Table of Electronics .....	45

## List of Equations

Equation 1: Bose's Distance Factor Equation .....	20
Equation 2: Maximum Distance from Intensity and Irradiance.....	23
Equation 3: Distance Factor .....	27

$$T_{vmotor} = \text{Torque of the vertical motor} = 139oz * in,$$

$$r_p = \text{Radius of the pinion} = 0.75in,$$

$$r_g = \text{Radius of the gear} = 6in, \text{ and}$$

$$d_c = \text{Distance to the console} = 6in.$$

$$W_{cmax} = \text{Maximum weight of the console},$$

$$d_c = \text{Distance to the console} = 6 in,$$

$$T = \text{Torque of the servo} = 70oz * in,$$

$$r_g = \text{Radius of the gear} = 0.75in, \text{ and}$$

$$d_g = \text{Distance to the gear} = 9in.$$

## List of Symbols

$IR1$	=	IR LED that transmits signal
$R2$	=	Current Limiting Resistor in Transmitter Circuit ( $\Omega$ )
$Q1$	=	Transistor (functions like a switch allowing power to flow to the diode)
$U1$	=	Integrated circuit
$C1$	=	Capacitor
$VBatt$	=	Input Power to transmitter (V)
$GND$	=	Ground
$Vcc$	=	Input power to IR receiver (V)
$Vout$	=	Signal out from receiver (V)
$Alpha (\alpha)$	=	TOP- angle between transmitter and receiver (Horizontal) (degrees)
$Beta (\beta)$	=	SIDE- angle between transmitter and receiver (Vertical) (degrees)
$D$	=	Distance between remote LED diode and front panel of the console (ft)
$d_{mmax}$	=	The measured maximum effective distance (ft)
$d_{emax}$	=	The expected maximum effective distance (ft)
$h_c$	=	Height of the console from ground to center of front panel of the console (ft)
$h_r$	=	Height of the LED of the remote (ft)
$DF$	=	Distance factor-a non-dimensional factor to scale the physical distance, $d$ , to the expected maximum distance, $d_{emax}$
$I_e$	=	Radiant Intensity of Transmitter (mW/sr)
$E_{emin}$	=	Irradiance (mw/m <sup>2</sup> )
$W_{cmax}$	=	Maximum weight of the console
$d_c$	=	Distance to the console from the front of console platform(in.)
$T$	=	Torque of the Iteration 2 Vertical Servo (oz * in)
$r_g$	=	Radius of the Vertical Motion gear
$d_g$	=	Distance to the Iteration 2 gear (in.)
$T_{vmotor}$	=	Torque of the Iteration 3 vertical motor (oz * in)
$r_p$	=	Radius of the Iteration 3 pinion (in.)

### Acronyms:

DOE	=	Design of Experiment
MSA	=	Measurement System Analysis
Gage R&R	=	Repeatability & Reproducibility
IR	=	Infrared Technology

## Overview of Bose Corporation IR Reception Testing

Bose uses Infrared (IR) signals in many of their commercially available products. Since there are no industry standards for quantitative performance testing, Bose wanted to create their own method of gauging the quality of their products.

The first step of the Bose testing process was to determine the maximum distance at which the remote could successfully send signals to the console at different orientations. This maximum distance was simulated by setting the value of the current limiting resistor located in the remote, R2, to a known value. The distance between the console and remote was then increased until the console was unable to receive a signal. This test was repeated for different orientations between the remote and console. The data collected from this test gave the maximum expected distance at which the system could successfully work when the console and remote were used in different positions. They did this test with two operators, 13 angular positions, and three repetitions per location using the same room, test system, and measurement system.

This test relies heavily on the experience and expertise of the test operator.

Bose noticed that the results of their tests were not repeatable or reproducible enough to easily compare product performance. It was also found that the testing process was lengthy and required cross-functional meetings to determine the quality of the product.

The goal of this study was to develop a new testing process that will eliminate a majority of the variability that is seen both from operator to operator and remote to remote. This new test will require less man-hours to complete and will not be dependent on the experience of the test operator.

## Infrared Transmitter and Receiver Research

Figure 1 is a basic schematic for an IR Transmitter/Receiver Circuit.

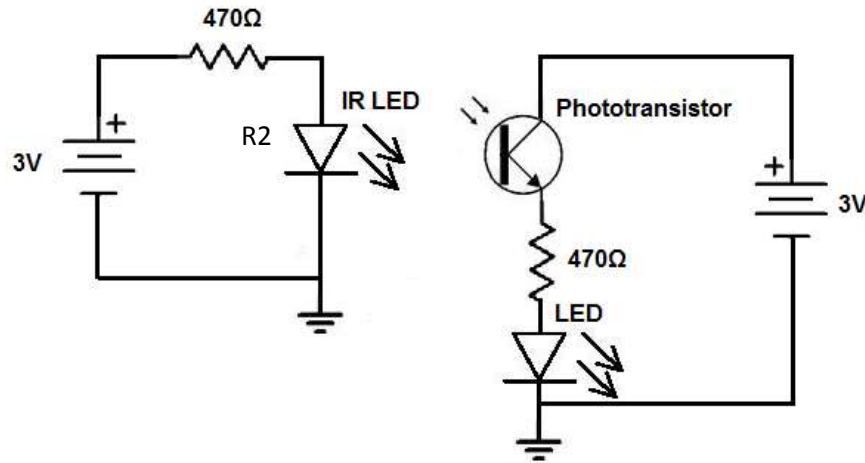

Figure 1: IR Transmitter / Receiver Circuit

The left of the schematic represents the transmitter, which in the context of this project would be the remote, while the right represents the receiver, the console. This circuitry shows that the output of the receiver should be the opposite of the output of the transmitter. Bose products follow the same general circuit and sample signals can be seen in Figure 2.

Infrared (IR) is a form of electromagnetic radiation that has a wavelength between  $0.78\mu\text{m}$  and  $1\text{mm}$ . This is longer than the visible spectrum and cannot be seen by the human eye. IR is most notably used in the remote controlling of household products, such as televisions and radios.

An IR transmitter consists of a Light Emitting Diode (LED) that emits IR radiation. In the context of the remote control, the LED sends a digital signal that can be interpreted by the targeted product. When these signals are received, the product processes the signal and performs the desired function, which is unique to that signal. Figure 2 is an example of a signal sent by an IR transmitter.

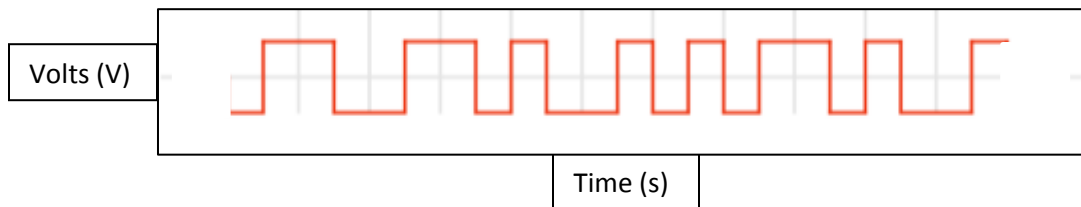

Figure 2: Standard IR Signal

The signal is a square wave because the LED is either on or off, creating a digital signal pattern.

On the other end of this signal is an IR receiver that receives the signal and detects its unique pattern. IR receivers include a photocell that is tuned to recognize infrared light. In many home entertainment products, IR receivers are programmed to only recognize signals from its corresponding remote. This

increases the efficiency of the system and reduces interference from other sources of infrared. There is also a demodulator that responds to IR signals only at a desired frequency, in the case of this project its frequency is 38 kHz. If the single sent from the remote is not at the same frequency as the console, the signal will not be received. Figure 3 shows a sample signal sent from the Bose remote.

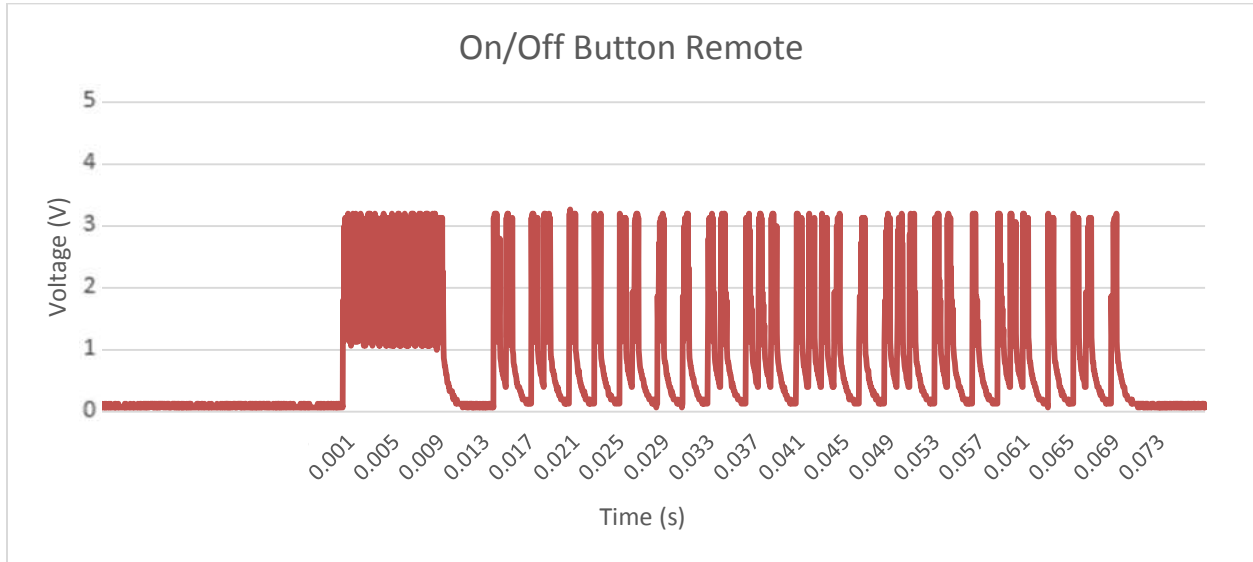

Figure 3: IR Transmitter Signal

IR LEDs can take up to 1 Amp of current for a very short amount of time. The diode pulses giving it time to cool off. The pulsing transmits a digital signal which is set to the specific frequency of the console.

### Dissecting Bose's Infrared Remotes

For this project, the Bose CineMate Universal Remote was used. It is shown in Figure 4 below.



Figure 4: Bose Universal Infrared Remote

This remote consists of a Button Pad, the Printed Circuit Board, the LED, the current limiting resistor (R2), and the Power Terminals.

Figure 5 and 6 display the front and back of the button pad that rests inside the top plastic case.



Figure 5: Bose Remote Button Pad, Top



Figure 6: Bose Remote Button Pad, Bottom

The top of the button pad is made of rubber. It has high lofted buttons that fit through the plastic case. The buttons are clearly labeled to communicate its function to the user. Beneath each button there is a conductive material that is concave into the button pad. When a button is pushed down the conductive material makes contact with the Circuit Board.

The Circuit Board has a contact connection circuit for each of the 53 buttons, as illustrated in Figure 7. When a specific connection is bridged with the conductive material on the button pad, the circuit is complete and the corresponding digital signal is sent to the LED.

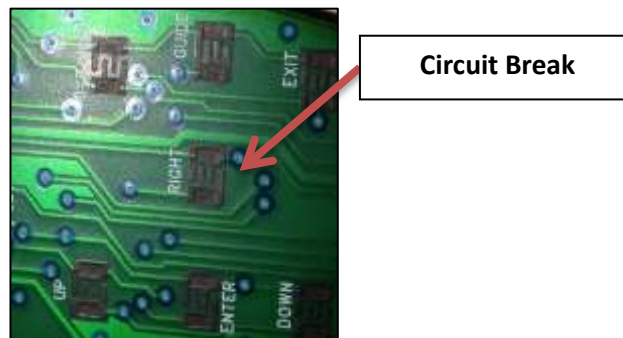

Figure 7: Circuit Break in CIRCUIT BOARD

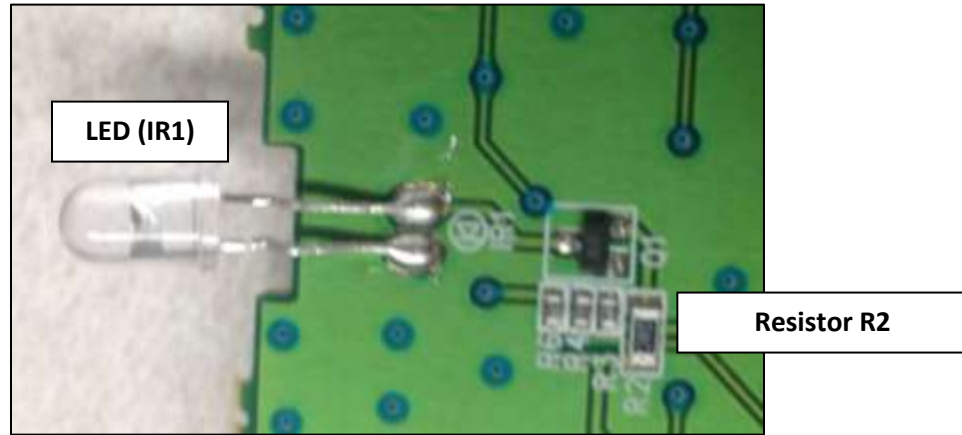

Figure 8: Bose Remote Infrared Subassembly

When the circuit is complete, the power coming into the remote must be sent to the LED. As the current flows through the circuit, it will pass through R2, a 2Ω resistor, that limits the current to the LED. From there, the signal is sent to the IR LED which will send out an Infrared Signal, as seen in Figure 2. The LED and R2 Infrared Subassembly are presented in Figure 8.

The resistor R2 was measured in four Bose remotes. The results are shown below in Table 1.

Remote	1	2	3	4	Average
Resistance (Ohms)	1.97	2.01	1.99	1.96	1.98

Table 1: R2 Measurements

The last important sub assembly of the remote is the battery connections, seen below in Figure 9. The remote is powered by two Alkaline AA batteries.

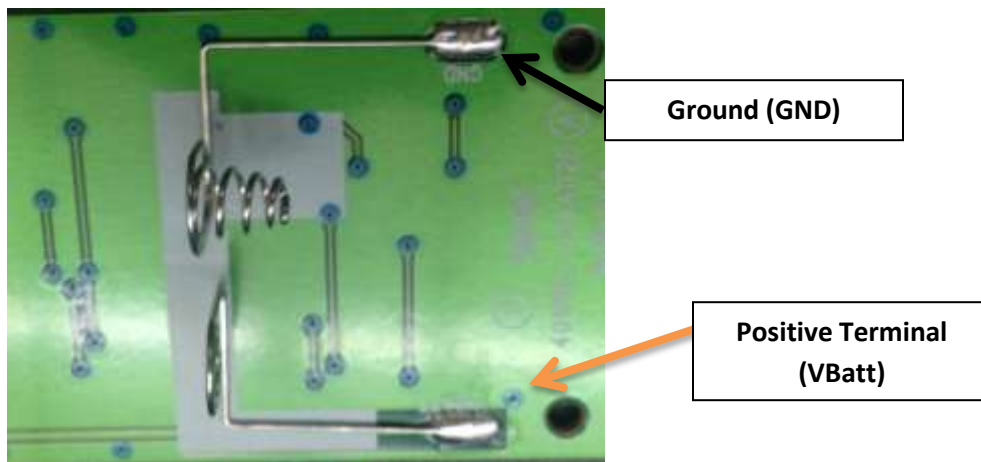

Figure 9: Bose Remote Power Input

The power supply connections connect to the positive and negative terminals of the two AA batteries. Instead of using the batteries, a constant power supply was used and set to 3.3V. The power supply is soldered into the circuit board so that the electricity from a constant power source can flow through the circuit once the circuit is bridged by pushing a button.

### Testing the Remote's Signal Output with an Oscilloscope

Before the team could begin to work on the infrared testing procedure for Bose, the output of IR1 needed to be analyzed. Figure 10 is a detailed picture that explains how the remote was connected to the Oscilloscope and the DC Power supply.

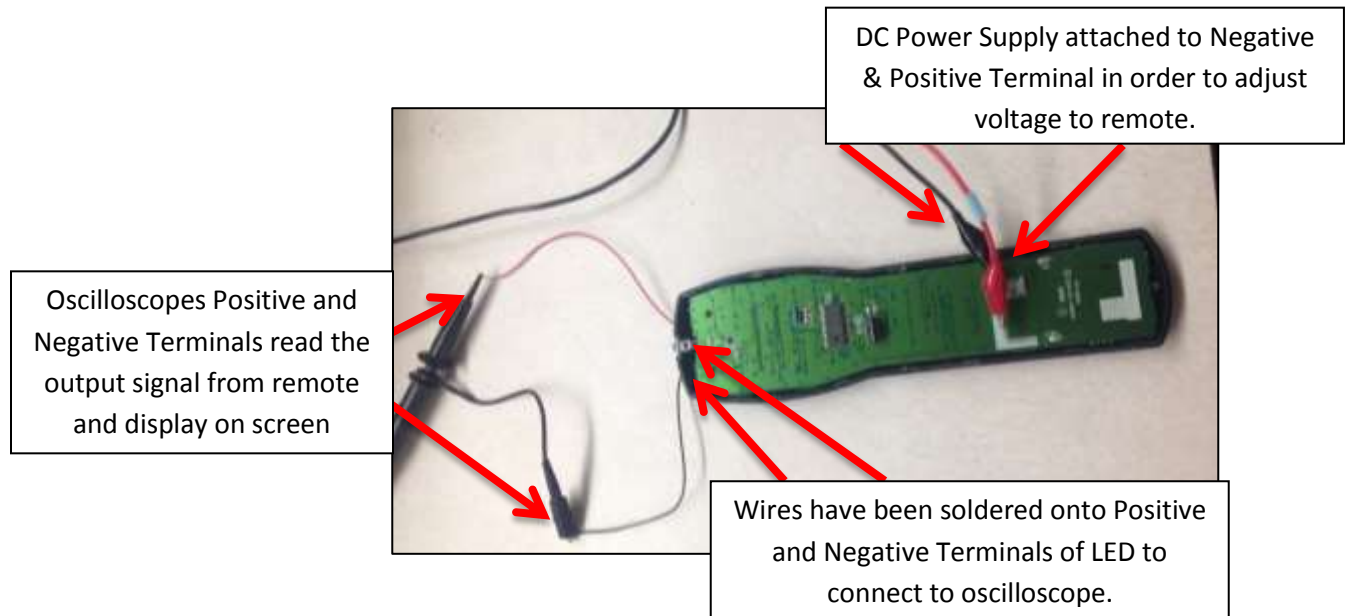

Figure 10: Bose Remote Connected to Oscilloscope and DC Power Supply

With the necessary components connected, the DC Power Supply was adjusted to 3.3V and 1A, and the “On/Off” button was pressed on the remote control. Figure 11 shows the voltage across the LED, which corresponds to the signal sent out.

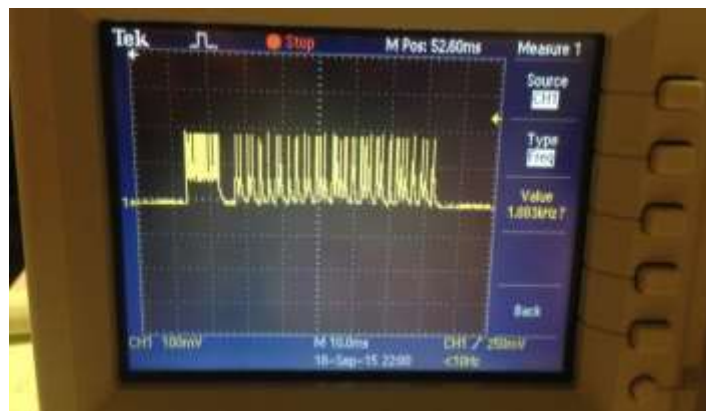

Figure 11: Bose Remote On/Off Signal Output



The first part of the signal, which consists of the segment of high frequency pulses for about the first ten milliseconds, is the remote syncing with the console. The signal following the sync is interpreted by the console as binary code, which allows the console to perform the desired task. Since the IR signal is modulated at 38 KHz, the graph above is a square wave. The data goes on to be demodulated, which the receiver does automatically.

### Dissecting the Bose Cinemate® 520 Console

The receiver of the remote’s IR signal is shown below. It is the Bose Cinemate® 520 console shown in Figure 12 below.



Figure 12: Bose Cinemate® 520

Figure 13 shows the major components of the console’s Circuit Board.

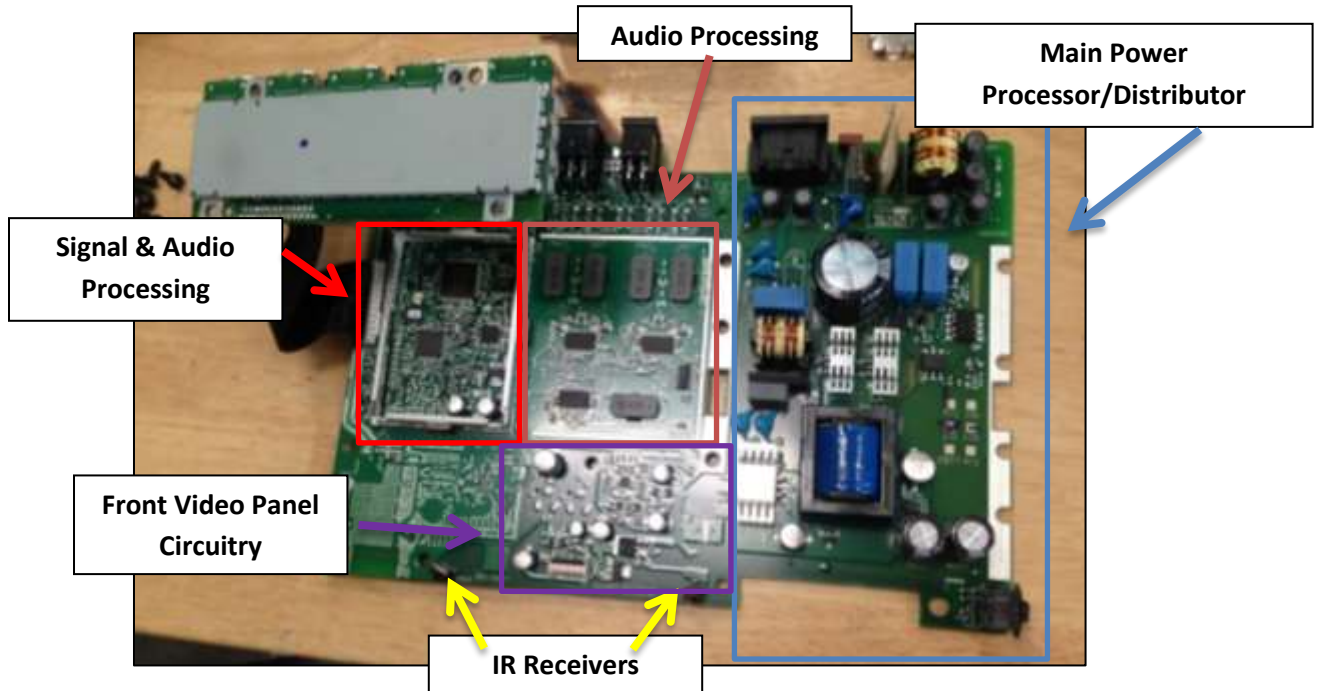

Figure 13: Breakdown of Bose Cinemate® Circuit Board

For this project, the most important components of the console are the two IR Receivers located at the front of the circuit board. A more detailed picture of these receivers can be seen in Figure 14.

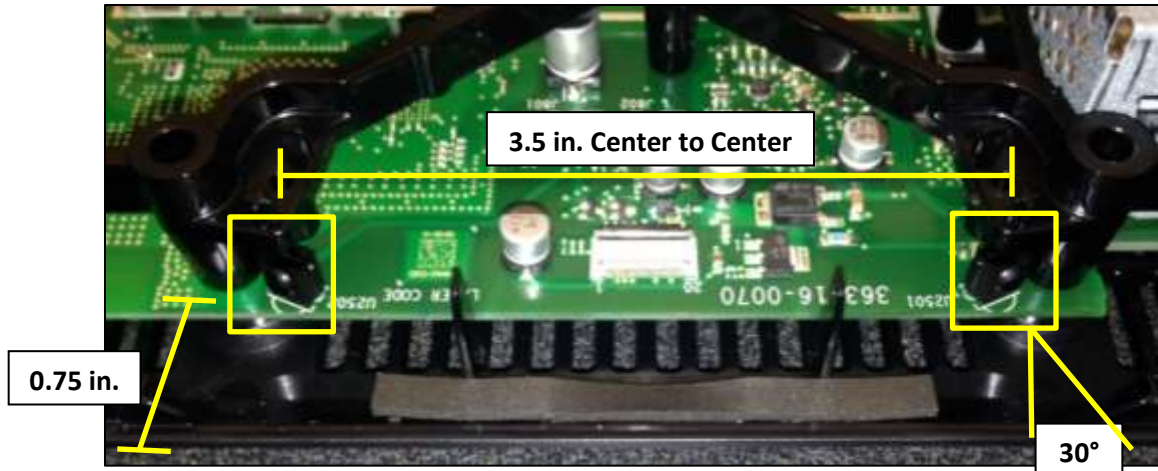

Figure 14: Close-Up of IR Receivers

The two IR receivers are attached to the front of the Circuit Board. The receivers for this product could not be placed flush with the front of the console due to cosmetic restrictions. This left an open space of approximately 0.75 inches between the front of the console and the receivers. The receivers are angled away from the center axis by 30°. This allows the console to have a greater effective area for signal reception.

In order to compensate for the 0.75 inch setback of the receivers from the front of the console two acrylic cylinders are used. The Bose team called them “light pipes.” Figure 15 shows how the light pipes funnel the IR signal to the IR receivers.



Figure 15: Internal View of the Light pipe and IR Receiver

## Bose’s Current Process

To fully understand the scope of the project, Bose’s current test process had to be assessed. Due to space constraints and the desire to decrease time Bose has determined a home-grown method of keeping the test in a standard living room sized room. Bose has modified the remote, by soldering out

R2, and replacing it with a switchbox of different resistances, ranging from 2Ω to 1024Ω, that can be turned on and off at will. This box can be seen in Figure 16.



*Figure 16: Bose's Switch Board*

The remotes are designed with R2 fixed at 2Ω. In order to adjust the value of R2, a switch board can change the resistance of R2 to 2, 8, 16, 32, 64, 128, 256, 512, and 1024 Ohms. When resistance is increased, it reduces the power output of the LED, which simulates an increase in distance between the remote and console. The relationship between the simulated distance and the physical distance is denoted as the distance factor ( $DF_{Resistance(\Omega)}$ ).

In order to calculate this distance factor, the test operator must first find the output power of the remote at each value of R2. Figure 17 shows the way that the Bose Team captured the output power of the remote. The remote is set up in front of a receiving box that contains a photodiode. A signal is sent from the remote to the photodiode, which is connected to an oscilloscope. The oscilloscope then reads in the signal that the photodiode is receiving and displays it to the test operator. By measuring the Pk-Pk value of the signal the operator can determine the Voltage (V) and Power (mW) of the signal received.



*Figure 17: Bose Current Test Setup*

The Bose team records the Power (mW) of the signal on the oscilloscope and relates it to the corresponding resistance of R2.

Knowing both the resistance (R2) and the signal Power (mW) at a range of resistances Bose then calculates the distance factor. They use Newton's inverse square law. This is the ratio between the output power of an unmodified remote, where R2 equals 2Ω, and the output power at varying resistances of R2. The square root of this ratio is the distance factor at that resistance. This can be seen in the equation below:

$$Bose's\ Distance\ Factor = \sqrt{\frac{(Output\ Power\ of\ Unmodified\ Remote)}{Output\ Power\ at\ Varied\ R2}}$$

*Equation 1: Bose's Distance Factor Equation*

The results of this calculation can be seen in the Table below. For example,  $DF_{16\Omega} = 2.1$ . This means that when the resistance of R2 is changed from 2Ω to 16Ω the signal strength is as if it were 2.1 times farther away though the remote is the same distance in both cases.

R2 (ohm)	P(mW)	Distance factor
2	418	1.0
8	154	1.6
16	93	2.1
32	50	2.9
64	24	4.2
128	11	6.2
256	4	10.2
512*	2.00*	14.5
1024*	1.00*	20.4

\* 512 and 1024 values are estimated because measuring equipment is not sensitive enough to make these readings.

*Table 2: Bose's Distance Factor Calculations*

Once the remote is discovered to be working properly, testing of the system begins. The testing fixture on which the remote is held, presented in Figure 17, is aligned with the desired console being tested. The receiver box with the photodiode is removed to clear a path for the signal to go to the console. A vertical laser mounted to the remote fixture helps to align the remote with the console. From here, the technician chooses an appropriate resistance for R2 based on the relative orientation between the two.

The test technician will then physically move the remote's fixture to find the maximum effective distance at the chosen value of R2. From here he presses the volume button 5 times. The test operator keeps moving the remote away from the console until only three of the five button pushes are received, he records the resistance value of the switch board and the distance away from the console, using a measuring tape. He then multiplies the distance he has measured by the distance factor specific to that R2 value. The distance calculated equals the expected maximum distance for an unaltered remote. This process is repeated for each desired orientation of the console-remote system.

## Simulating Distance

Before moving forward with resistance as the method of simulating larger distances, the team needed to first validate that this was a feasible addition to the test and not the source of test variation. Simulating distance is a crucial part of the test because it allows Bose to conduct the test in a smaller area.

## Specifications of the Transmitter

The team needed to fully understand the fundamental concepts and components that relate to simulating distance. There are two sides of the issue of simulating distance: There is the signal sent out of the remote and conversely the receivers that pick up that signal and turns it into a command. If one, or both, of these components are not working correctly then the test will not be successful.

Bose uses outside manufacturers for many of its components, these manufacturers provide specification sheets for the transmitter. On this specification sheet is important information about the radiant intensity of the LED. Figure 18 plots the relationship between relative radiant intensity and the forward current supplied to the LED.

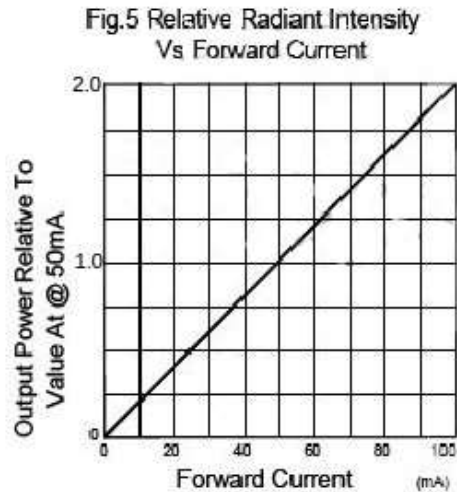

Figure 18: Relative Radiant Intensity vs. Forward Current

As the forward current increases, the radiant intensity of the LED increases linearly. The radiant intensity of the signal also changes depending on the angle of the transmitter. Figure 19 shows this below.

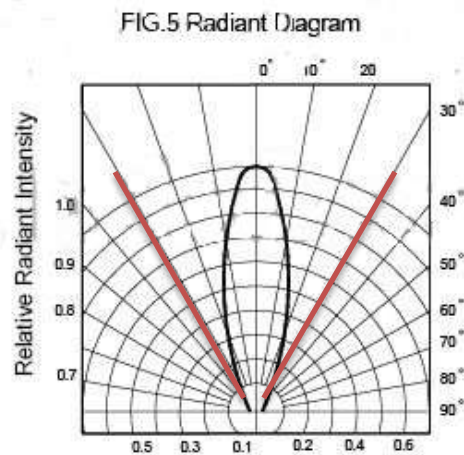

Figure 19: Radiant Diagram

At 0°, or on-axis, the radiant intensity is at a maximum relative, while at 10° and -10°; it drops to 70% relative. Any radiant intensity outside of the red lines, ±30°, is negligible.

### Theoretical Distance Factor

To determine the maximum distance that the IR signal can be detected the following equation is used.

$$d_{max} = \sqrt{\frac{I_e}{E_{min}}}$$

$d_{max}$  = Maximum Distance signal can be detected in ft.

$I_e$  = Radiant Intensity in mW/sr. Radiant Intensity is the radiant flux emitted, reflected, transmitted or received, per unit solid angle.

$E_{emin}$  =Irradiance in mW/m<sup>2</sup>. Irradiance is radiant flux (power) received by a surface per unit area.

*Equation 2: Maximum Distance from Intensity and Irradiance*

In order to solve for the Radiant Intensity ( $I_e$ ), measure the Forward Current (in mA) at a set resistance then use Figure 18 to relate it to relative output power. Then multiply the output power by the typical radiant intensity of the diode, which can be found in the LED specifications document provided by the manufacturer.

Unfortunately, it is difficult to determine minimum irradiance ( $E_{emin}$ ) for the IR receiver to successfully interpret the sent signal. Even if the minimum irradiance for the receiver used was found, each product would be different because each console design is different; some have light pipes, IR translucent cloth or other cosmetic features that interfere with the IR transmission. Knowing this theoretical calculation could not work for our purpose the team moved towards determining the distance factor experimentally.

## Experimental Distance Factor

In order to combat the variation between products and the large number of variables involved in calculating the distance factor theoretically, an experimental procedure was created to relate true distance to simulated resistance.

### Modifying the Remote

Before experimental testing of the distance factor could begin, each remote needed to be modified to utilize a DC to DC converter, which generates a regulated DC voltage, as a replacement power source to batteries and a method of changing the resistance of R2. Two wires were soldered to the VBatt and Ground components of the remote. By using these wires, the buck boost converter can replace the batteries. This DC to DC converter has the ability to take an input voltage and convert this to the desired output voltage. This is a beneficial addition to the testing fixture because it allows for power to be supplied to the remote at a consistent value, removing the possibility of batteries dying during the test. Figure 22 shows the yellow and orange wires soldered in to allow for the DC to DC converter to be attached.



*Figure 20: Wires Soldered into Power Supply*

R2 was then removed and green wires were soldered on that could be connected to an alternative way to change the resistance. This is shown in Figure 21 below.

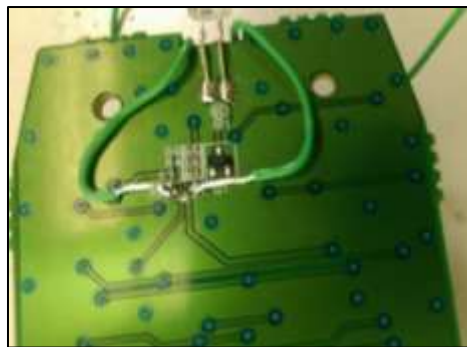

*Figure 21: Wires Soldered in Place of R2*

With wires replacing both R2 and VBatt, a breadboard was used to organize both components. The green wires were run through the breadboard to connect to a 1000Ω multi-turn potentiometer. This would allow easy and in-depth variation of R2. This is seen below in Figure 22.

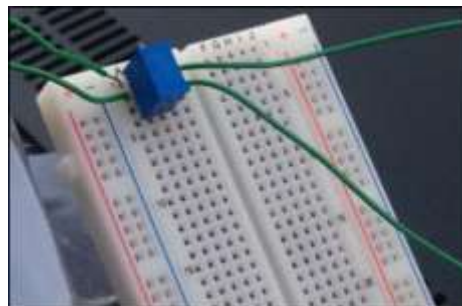

*Figure 22: R2 Replaced with 1000Ω Potentiometer*

The whole set up with the remote, potentiometer, and DC to DC converter can be seen below in Figure 23.





*Figure 23: Remote Using Consistent Power Supply and Potentiometer*

These modifications benefit the test by increasing the ease and speed at which different parameters such as resistance and power, if needed, can be changed. The use of the breadboard makes access to changing the resistance more comfortable for the operator, and since the potentiometer has the ability to change resistance continuously, more precise data can be collected.

This also allows the operator to find the appropriate resistance threshold at a given distance as opposed to finding the correct distance to a set resistance. Eliminating the need to move the remote reduces measurement variation and time by limiting how often the operator has to re-align the system properly and re-measure the distance.

### Running the Experiment

The Experimental Distance Test was conducted by measuring the resistance threshold of 3 different remotes from 5 feet to 50 feet at intervals of 5 feet. When the receiver missed 8 of the 10 commands sent, the resistance was recorded. A multi-meter was used to read the values of the resistance. The test was conducted in a dark, open space to remove any environmental effects. The setup is shown in Figure 24.



*Figure 24: Set Up of Distance Factor Experiment*

The alignment of the entire test system was verified using a vertical laser. The laser ensured that the LED of the remote was in line with the center of the console's front panel.

After conducting the test multiple times, the data was compiled into Table 3.

<b>Experimental Distance Test</b>				
Distance (ft)	Remote 1 Resistance of R2 ( $\Omega$ )	Remote 2 Resistance of R2 ( $\Omega$ )	Remote 4 Resistance of R2 ( $\Omega$ )	Average Resistance of R2 ( $\Omega$ )
5	307	335	315	319
10	138	155	145	146
15	75	82	78	78
20	48	53	48	50
25	31	30	29	30
30	23	20.5	19	20.8
35	14.9	14.9	14	14.6
40	10.1	9.9	9.3	9.8
45	7.9	6.7	6.8	7.1
50	5.4	4.5	4.8	4.9
55	5	3.1	3.5	3.9

Table 3: Max Resistance at Set Distance

This shows that at 5 feet away R2 could be adjusted to 319 $\Omega$  and still receives 8 of the 10 signals sent out by the transmitter. This data can be better represented in the form of a graph with a trend line. Figure 25 shows the Distance vs. Resistance graph for Remote 1, and Figure 26 illustrates a semi log plot of the same data.

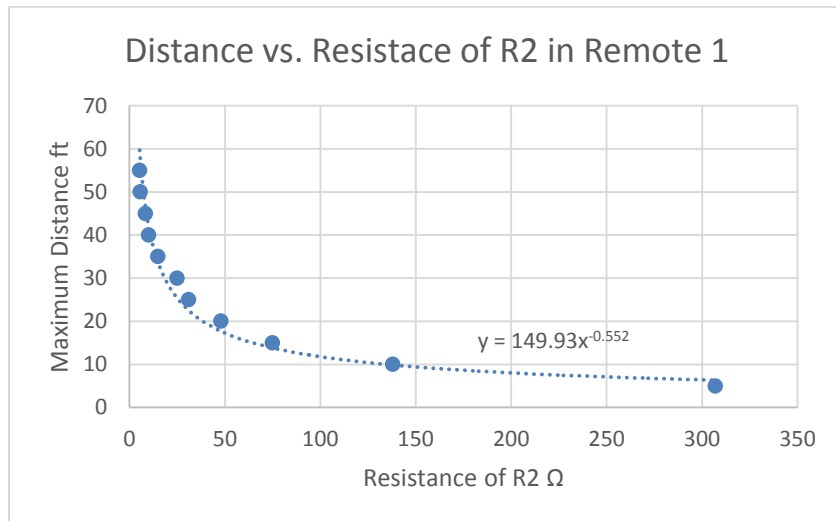

Figure 25: Distance vs Resistance of Remote 1 R2

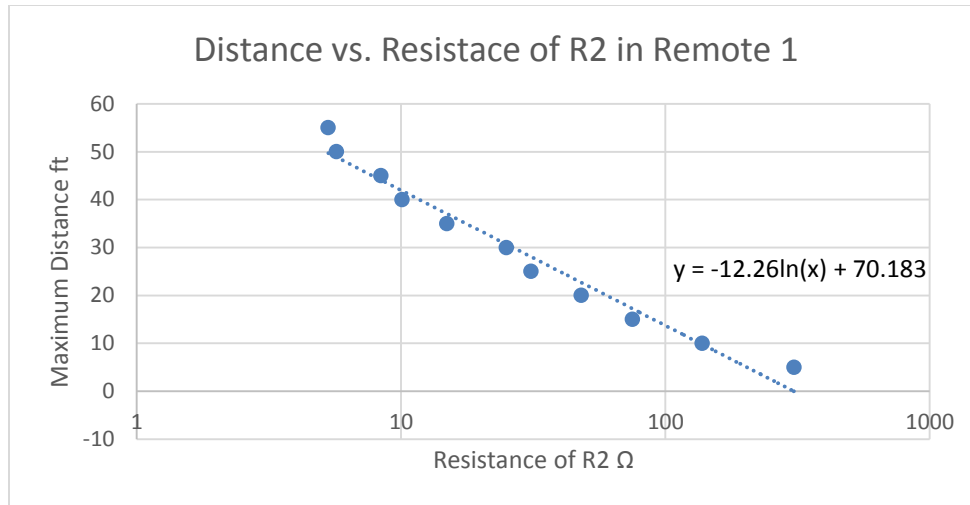

Figure 26: Distance vs Resistance of R2 in Remote 1 Semi Log Plot

Creating a semi log plot of the data is beneficial because it plots the relationship between the distance and resistance data as a straight line. A test operator can find the resistance threshold at only a few points, and based on the slope of the line, confidently extrapolate any distance for a given resistance. This will reduce the time needed to create the equation for simulating distance by a factor of 1/2. The distance simulation will change for every remote and console assembly. The procedure to find the simulated distance can be found in the SOP in Appendix C.

Now that you have the relationship between R2 and the Maximum Distance an IR signal can travel to still turn on the Cinemate, the equation to find the Distance Factor can be found. The relationship used is the ratio between the expected maximum distance of an unaltered remote, where R2 is 2Ω and the expected maximum distance at any resistance, as seen in Equation 3.

$$Distance\ Factor\ (DF_{Resistance\Omega}) = \frac{Maximum\ distance\ at\ R2 = 2\ \Omega}{Expected\ maximum\ distance\ at\ varying\ resistances\ of\ R2}$$

Equation 3: Distance Factor

By relating the maximum distance at a resistance of 2 Ω and the maximum distance at any resistance, the necessary scaling factor unique to each resistance can be calculated. Once this scaling factor is calculated, it can be multiplied by the distance between the remote and console to simulate the true distance at which the console could work unrestricted circumstances.

For example, for the Cinemate 520 Console and the Bose Universal Remote the Maximum Distance measured at 2Ω was 85 feet. At 10Ω the expected maximum distance is roughly 40 feet, as seen in the calculation below.

$$DF_{10\Omega} = \frac{85}{45} = 1.88$$

Henceforth, if the remote is 10 feet away from the console when it is set to  $10\Omega$  it is simulating a distance of  $1.88 * 10\text{ft} = 18.8\text{ft}$ .

### Comparing Results

After calibrating the distance factor equation experimentally and theoretically, it was vital to compare the results to how Bose calculates the distance factor used during their testing. This was done by using the same procedure that Bose used on Remote 2, and experimentally finding the distance factor curve. The graph below illustrates these two different methods of obtaining the distance factor.

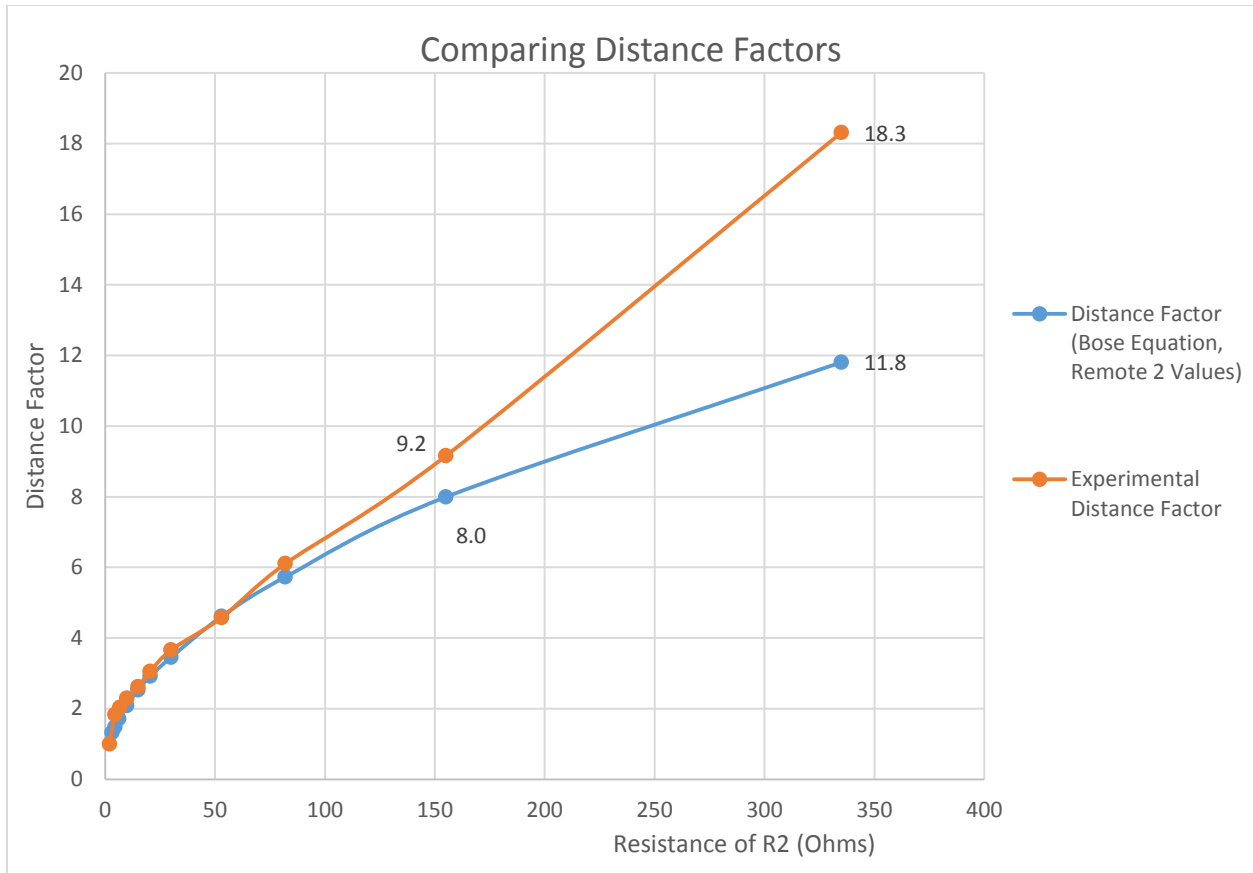

Figure 27: Comparing Distance Factors

Using this graph as a reference, the two methods of determining the distance factor diverge significantly after  $R2$  exceeds  $150\Omega$ . This means that as long as the resistance stays under this maximum, either testing method is able to reliably get the equation for the distance factor.

## Variability in the Test Process

After getting a better understanding of how Bose tests their remotes, it was important to analyze the possible factors that could be increasing the variation in the test and determine methods to mitigate these potential factors. The fishbone diagram in Figure 28 shows the main opportunities for variation.

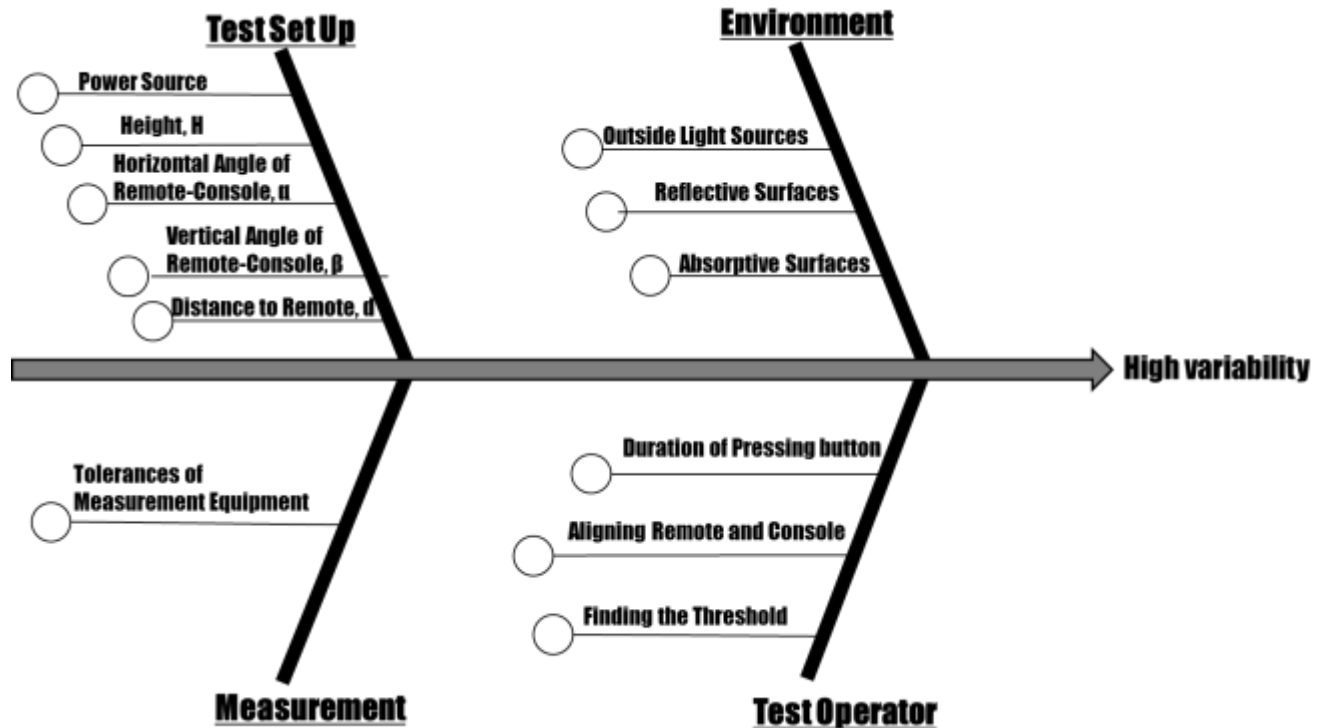

Figure 28: Fishbone Diagram

### Test Set-Up

The power source of the remote is designed to be batteries. However, as the team began their preliminary testing of the remote and console, it became apparent that signal transmission became poor as batteries lost power. Research was conducted and it was apparent that there was a correlation between battery power and signal output. Testing of signal transmission and reception at varying remote voltages was then conducted. It was discovered that there was a major relationship between signal output and battery life. A power of 2.6V makes the remote unable to send out the signal. Considering that the test takes multiple hours and includes substantial usage of the remote, continuing to use traditional batteries in the test would require the need to test the output voltage of the batteries at each step in the testing process.

Rather than testing the output voltage of the batteries throughout the test, which would increase the total testing time, a constant power source should be used. For these tests a DC to DC converter is used, this DC to DC converter allows the operators to select any desired voltage. Doing this will eliminate the need to test the power to the VBatt component of the remote more than once. This is a simple solution that reduces the variability and time of the test.

The height of the console and remote is significant in two ways. First, the LED should be the same height as the center of the console. This is because for our tests, it is assumed that the user knows that the remote needs to be pointed at the console, but does not know where the receivers are. The center of the front of the console is the point chosen to be consistent throughout the testing. Second, the testing system needs to be at least 3 feet from the ground to eliminate IR bounce from the floor reflecting into the receiver of the console.

The tolerance of the relative angle between the console and remote, signified by  $\alpha$  and  $\beta$ , is another source of variability. These Angles are shown in Figure 29 and 30 below.  $\alpha$  is the Horizontal Angle and  $\beta$  is the Vertical Angle.

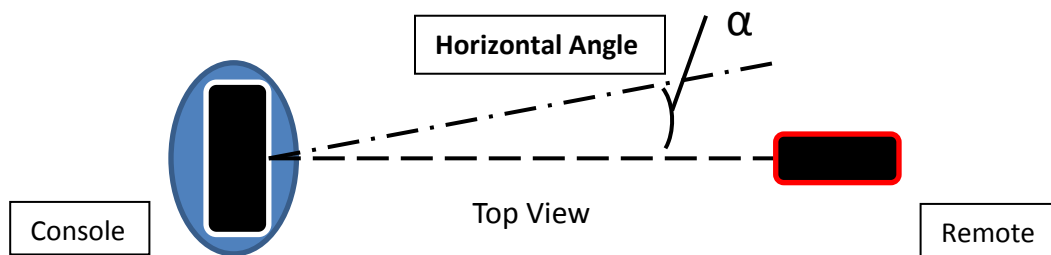

Figure 29: Horizontal Angle

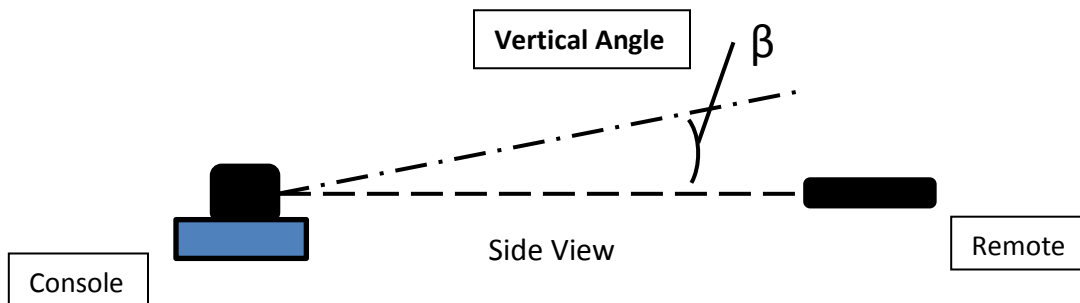

Figure 30: Vertical Angle

Currently the test uses a protractor to measure these angles, but fixtures may be made in the future to more precisely set the angles. The distance between the remote's LED and the front of the console is determined using a measuring tape.

## Environment

The testing environment can impact the test through interference from ambient light and reflective surfaces. The most efficient method to eliminate environmental factors is to conduct the test in a dark, spacious room. Since space is a limiting factor for Bose, the test system proposed needs a calculated clearance of at least four feet on each side of both the remote and console. This would reduce the effects of IR bounce to a negligible amount.

## Test Operator

Knowing that the signal sent from the remote repeats while the button is pushed, this is another opportunity for variation in the test results. Since the test operator is manually pushing the button throughout the test, there is no way to measure exactly how many signals are sent out per button push. Since signals are sent out every 85 milliseconds, small differences in button push length could result in a large discrepancy of signals sent out. This could be eliminated by either reprogramming the remote to send a set number of signals each button push, or to have a mechanism push the button for the operator. A solenoid is a reasonable option for this task. Solenoids are simple electromechanical devices that are easily programmable, and can be set to press the button for a set amount of time. Having a mechanism would also be able to change between remotes easily, whereas reprogramming each remote would be difficult and time consuming.

The remote has to be properly aligned with the console for the test to be consistent. This can be done using a vertical laser centered on the console, and projecting the laser onto the remote. The vertical laser allows the light to be seen on both the front and back of the remote, and this ensures the proper alignment of the remote and console.

The Bose test has the threshold of acceptance at receiving 3 out of 5 signals sent out; however, this could be increased to 8 out of 10 without a significant increase in time. Doing this will ensure that the test operator finds a consistent threshold to be recorded, and also the increased number of data points also raises confidence that the operator found the correct threshold.

## Determining Elements of the Procedure

In order to create an effective procedure to test the results various factors had to be evaluated. The three major aspects of this test are the angle, the distance, and the data.

The morphological chart in Table 3 was used to determine the different possible testing processes. After using the morphological chart to find the most promising possibilities, a design matrix is used to narrow those choices down.

Morphological Chart						
<b>Changing the Relative Angle</b>	Changing $\alpha$ and $\beta$ of console	Changing $\alpha$ and $\beta$ by moving the remote	Changing $\alpha$ by varying remote, change $\beta$ by varying console	Changing $\alpha$ by varying console, change $\beta$ by varying remote	Changing $\alpha$ and $\beta$ by moving remote in Y and Z axis, keeping rotation constant	
<b>Varying Relative Distance</b>	Varying distance between remote and console	Fixing distance and varying resistance of R2	Fixing R2 to a higher value and changing physical distance to remote	Fixing R2 and relative distance	Moving Console instead of remote	Changing both distance and resistance of remote
<b>Output Data</b>	Maximum distance reliably receiving signal	Percentage of received signals				

Table 4: Morphological Chart of Possible Testing Processes

### Changing the Relative Angle

In order to vary the angles between the test components, the relative angle between the console and remote needs to be altered, this can happen either by rotating the console or the remote about the origin or combinations of rotations.

Changing the Horizontal and Vertical angles of the console will be the best method of representing different remote orientations in real world situations. By changing only the receiver's orientation, the remote stays on the same axis relative to the testing fixtures. Doing this will limit both the necessary space and the effects of IR bounce that are present due to the properties of the room, including the surface of the walls, ceiling and floor. Sending the signal from a constant location will reduce the environmental effects that would otherwise be present by having the remote move throughout the room. This will yield more consistent data and increase the possible testing areas by eliminating the need for a wide, symmetrical room.

### Varying Relative Distance

The testing requires the ability to change the distance between the console and the remote. This can be done by physically changing the distance or simulating distance by changing the R2 value. The morphological chart shows the different possibilities for varying the relative distance.



Varying both the distance and resistance was eliminated because this will create multiple combinations of physical distance and resistance at each angle that creates the same maximum distance. This means that it increases test time with no gain in repeatability.

## Output Data

This section of the morphological chart refers to what type of data the test is measuring. Both the maximum distance and percentage of received signals are feasible. These are interchangeable and both could work for most testing processes.

## Narrowing to Two Procedures

Presented below, in Table 4, is the weighted decision matrix used by the team in order to decide which design concept to move forward with. The key elements of the test that were considered were Projected test time, Potential for human error, required space, ease of test set up, potential cost of fixtures, and required test operators. Since there is currently such large variation in results between different test operators, addressing the issue of human error was the top priority in the new test. Not only is the current Bose test time consuming, but the cross functional meetings that need to happen as a result of the large test variation take hold of many of Bose’s resources. As a result shortening the actual test time and mitigating the need for excessive meetings was the next most important factor to consider. Following these two major test portions, the test needed to be easily set up and also be space efficient.

<b>Weighted Decision Matrix</b>			
	Scaling Factor	1: Fixed Distance, Fixed Resistance	4: Fix Distance, Vary Resistance
<b>Projected Test Time</b>	.2	5 → 1	2 → .4
<b>Potential for Human Error</b>	.3	5 → 1.5	3 → .9
<b>Required Space</b>	.1	3 → .3	3 → .3
<b>Ease of Test Set Up</b>	.2	4 → .8	3 → .6
<b>Potential Cost of Fixture</b>	.1	4 → .4	4 → .4
<b>Required Test Operators</b>	.1	4 → .4	4 → .4
<b>Total</b>	1.0	4.4	2.4

*Table 5: Weighted Decision Matrix*

The most important elements of this test were the Potential for Human Error and projected test time as those would directly correlate to the accuracy of the results and the reduction of time necessary. The

cost and required space were not as important to completing the deliverables required so less weight was put on them.

### **Concept 1: Fixed Distance & Fixed Resistance**

This process would have the remote a fixed distance away from the console. The console itself would be able to rotate to all desired angles to test signal reception. In order to keep the testing in a confined area, R2 will be replaced with a resistance of a higher value that will remain constant. For this specific test, the recorded output will be the percentage of signals received.

The benefits of this specific testing procedure are in the reduced time and potential for operator error while executing the test. Keeping the remote and console at a fixed distance removes both the extra time required to change the distance between the two test components, and the always present variation in measuring the distance and relative angles. The scaled down testing area made possible due to the increased resistance of R2 is also beneficial to the versatility of the test. Scaling the test down to a point where it can be performed in a standard sized room, under 20 feet, allows for the test to remain consistent. Finally, eliminating the need to translate the remote and console relative to the testing room during the test minimizes environmental influences on the test, mainly reducing the impact of the asymmetrical properties of many rooms, improving the quality of recorded data.

Since this test is in a reduced area and only requires the test operator changing the console's orientation, the test could also be shrouded in an IR absorbent sheet. This would completely eliminate IR reflections and cause the testing procedure to be the worst case scenario. This would allow Bose to be confident that the product will work better for the customer than represented by this test. Also, if this product is going to be used in a specific setting that has known environmental factors, different types of lights could be added beneath the shroud as a new variant to the test.

The drawbacks to this testing procedure are that maximum distance cannot be calculated. Recording the percentage of button presses at various angles and a specified distance will not record exactly how far away a signal can be received, which does not allow the operator to see which orientation has the best results.

### **Concept 2: Fixing Distance & Varying Resistance**

The remote is fixed, and the console will rotate about the origin to test different values of  $\alpha$  and  $\beta$ . The resistance of R2 is increased until the signal is received only 8 out of 10 times.

Through the use of a potentiometer, changes in distance will be able to be accurately represented without ever needing to change the physical distance between the remote and console. By only needing to change the resistance, R2, test time will be greatly shortened, and since the orientation of the remote with respect to the console never changes, human error will be greatly reduced. By rotating the console, the remote does not need to move laterally, which keeps environmental effects to a minimum throughout the test, keeping results consistent. The results of this test would give in depth measurements of the angles from which the console receives signals from the farthest distance. This is represented through a color coded table.

## Sample Test Results

Conducting each of the preliminary concepts produced results that are shown below. Table 5 shows the results of the Fixed Distance, Fixed Resistance test in the form of percentages. Table 6 shows the results of the Fixed Distance, Varying Resistance test in the form of distances in feet.

R2 = 100  $\Omega$   
Horizontal Angle  $\alpha$  (Degrees)

	-40	-30	-20	-10	0	10	20	30	40
30	0%	0%	0%	0%	0%	0%	0%	0%	0%
20	0%	0%	50%	100%	100%	100%	0%	0%	0%
10	0%	0%	100%	100%	100%	100%	100%	0%	0%
0	0%	40%	100%	100%	100%	100%	100%	0%	0%
-10	0%	0%	100%	100%	100%	100%	0%	0%	0%
-20	0%	0%	0%	0%	0%	0%	0%	0%	0%
-30	0%	0%	0%	0%	0%	0%	0%	0%	0%

Vertical Angle,  $\beta$  (Degrees)

Table 6: Fixed Distance Fixed Resistance Results

The results from this test can be seen as a graph of the percentage of successful signals received, out of ten. Every console orientation that results in 80% reception or higher is considered a success. This test would have to have a baseline created from the distance factor unique to each remote considering that in order to compare results across products; the results need to be easily understood. The easiest way to do this would be to set an expected distance as the standard and back calculate the required resistance of R2 to simulate this distance.

The results from the second concept can be seen in the table below.

		Expected Maximum Distance (Feet)								
		Horizontal Angle, $\alpha$ (Degrees)								
		-40	-30	-20	-10	0	10	20	30	40
Vertical Angle, $\beta$ (Degrees)	-30	0	0	16	18	33	22	17	0	0
	-20	0	11	53	77	83	80	63	10	0
	-10	10	33	80	90	95	102	72	35	10
	0	14	62	91	106	98	112	82	50	11
	10	10	48	86	101	89	92	85	37	14
	20	0	29	76	89	94	92	71	25	0
	30	0	0	24	50	59	44	21	0	0

Table 7: Fixed Distance Varying Resistance Results

This test took significantly longer than the first, but gives more information about the system. The profile of best reception is very comparable to the elliptical shape seen in Table 6. This table shows that the remote is the most effective not straight on the console, but at a 10 degree offset. This is understandable since the two receivers are not in the center of the console and are facing at an angle outward.

### Final Procedures

After researching more about the environment that Bose’s home entertainment division markets to, the team determined that it would be best to set a baseline distance at each angle that the system has to pass in order to meet standards. Using the information that the average living room in a large house has the dimensions 18 feet by 13 feet by 10 feet, the maximum possible distance a remote can be from the console is about 25 feet. Since this is an average living room and Bose’s company culture always tries to exceed the minimum, the team determined that the resistance should be set to simulate 70 feet between  $-10^\circ$  and  $+10^\circ$ , 50 feet for  $-20^\circ$  and  $+20^\circ$  and 30 feet for  $-30^\circ$  and  $+30^\circ$ . Using this system, the test operator can quickly change the resistance of R2 to the necessary value and the test will ensure that the IR system is able to function well in a large room.

Another constraint is that the value of R2 should not exceed  $150\Omega$ , since the distance factor equation diverges from the actual simulated distance as the value of R2 increases. The physical distance between the console and remote can be adjusted to ensure that R2 stays under this maximum, but the physical distance should be constant throughout the entire test. For the tests conducted during this MQP, the physical distance used was a constant 10 feet. The table to record the data for this procedure is seen below in Table 8.

		Horizontal Angle (°)						
		30	20	10	0	-10	-20	-30
Vertical Angle (°)	30							
	20							
	10							
	0							
	-10							
	-20							
	-30							
		30	50	70	70	70	50	30
		Distance Simulated (ft)						

Table 8: Baseline Reception Test Template

For a detailed look at the reception of the console the Expected Maximum Distance Test would be used. This would allow the operator to distinguish any areas of total blindness, areas of excellent reception and the general profile that the IR signal is consistently received at. Table 9 is the template for recording the data for this test.

		Horizontal Angle, $\alpha$ (Degrees)								
		-40	-30	-20	-10	0	10	20	30	40
Vertical Angle, $\beta$ (Degrees)	-30	Red	Red	Orange	Orange	Yellow	Orange	Orange	Red	Red
	-20	Red	Orange	Light Green	Light Green	Light Green	Light Green	Light Green	Orange	Red
	-10	Orange	Yellow	Light Green	Light Green	Light Green	Light Green	Light Green	Yellow	Orange
	0	Orange	Light Green	Light Green	Light Green	Light Green	Light Green	Light Green	Light Green	Orange
	10	Orange	Yellow	Light Green	Light Green	Light Green	Light Green	Light Green	Yellow	Orange
	20	Red	Orange	Light Green	Light Green	Light Green	Light Green	Light Green	Orange	Red
	30	Red	Red	Orange	Yellow	Light Green	Yellow	Orange	Red	Red

Table 9: Expected Maximum Distance Template

## Creating Testing Equipment

Once the method of simulating distance had been established and the process was locked down, it was necessary for the team to work toward improving the variability in the test from a physical operation stand point. Previously in the test, operators would set the fixtures to distances and angles by hand. With no automation or set guidelines to help gage the consistency of the test setup between operators, creating fixtures that alleviated this issues were necessary. In order to refine the test even more substantially, the team worked on designs and prototypes of fixtures that could make the test more reliable and faster. Before diving into the design process the team created a list of design specifications and a morphological chart to organize ideas.

## Design Specifications

### Appearance Specifications

- The final product should not have any surfaces that easily reflect Infrared Waves to the console

### Weight Specification

- The fixture must be capable of lifting and holding the weight of a 15 pound console.

### Dimensions Specification

- The fixture must be at least 10" wide and 8" deep and 7" tall.
- The fixture must be able to hold a console that is 18" by 12"

### Function Specifications

- The Fixture must have 2 degrees of freedom around an axis of rotation in the Front Center panel of the console
- The Horizontal Motion ( $\alpha$ ) must rotate from  $-30^\circ$  to  $+30^\circ$
- The Vertical Motion ( $\beta$ ) must rotate from  $-30^\circ$  to  $+30^\circ$
- The console fixture must have a way to hold the console in the center of the platform up to the very edge of the platform
- The Fixture must be programmable

### User Specifications

- The device is intended for but not limited to people working for Bose Corporation who need to evaluate their IR systems
- The device gives the user the ability to test many different data points quickly and efficiently by reducing the time to adjust the angle and the accuracy of the adjustments.

## Morphological Chart

Morphological Chart				
Vertical Angle Fixture	Pin Holes With Spring	Notched Slide	Rack and Pinion	Gear to Gear Contact
Horizontal Angle Fixture	Pin Holes With Spring	Notched Slide	Lazy Susan	Gear to Gear Contact
Automation (If Possible)	Arduino Connected to High Torque Servo	Arduino Connected to Gear Motor with Encoder		

Table 10: Console Fixture Morphological Chart

## Design Iteration 1

Creating a reliable testing fixture that could automatically change the test angles for the test operator was necessary for the fixture of this IR test. For this reason, the team looked into the use of servo motors and the use of a rack and pinion sub assembly as a method of achieving the desired automated vertical motion.

In order to accomplish the vertical motion necessary the following design was drafted up. This design utilized support beams in the front that would allow the center of rotation to aligned with the front of the console. By lifting the console platform up this high the console would be able to rotate down 30° as well as up 30° easily. Figure 31 shows the rough design of the vertical motion.

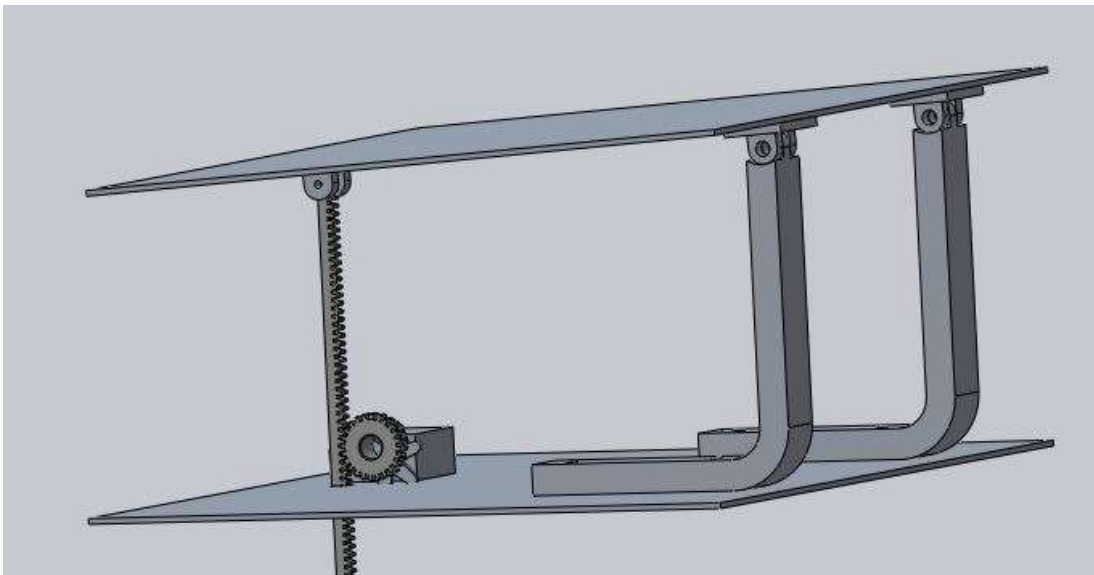
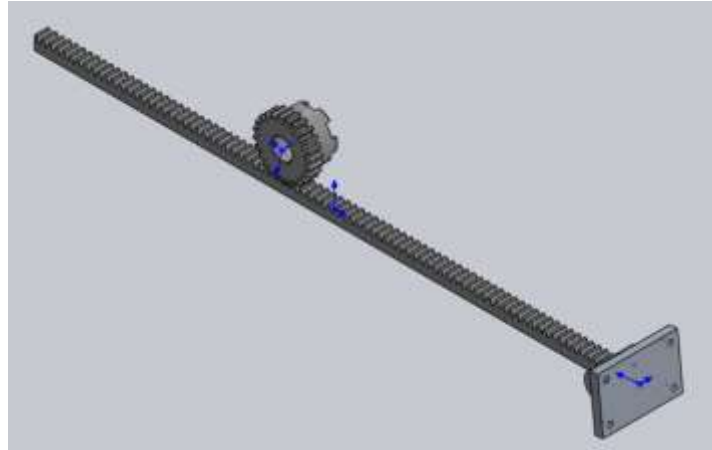

Figure 31: Design Iteration 1

This design utilized a rack and pinion mechanism to raise and lower the platform which was moved by a gear that fit snug onto a servo attachment. The servo was a high torque continuous rotation servo. Figure 31 displays the rack and pinion mechanism in more detail.



*Figure 32: Rack and Pinion Mechanism*

This mechanism was 3D printed and tested to see how it would perform with two acrylic sheets used for the top and bottom panels.

It was found that the rack would not stay perfectly perpendicular to the gear mechanism. This meant that the team would have to find a way to ensure the rack would not kick out under the weight of the console and platform.

## Design Iteration 2

The second iteration included both the vertical and horizontal movements of the fixture.

### Vertical Motion

Building off of the original design for the console fixture, the team kept the core concept of the rack and pinion as the basis of this design iteration. The main improvements that came about in this iteration are

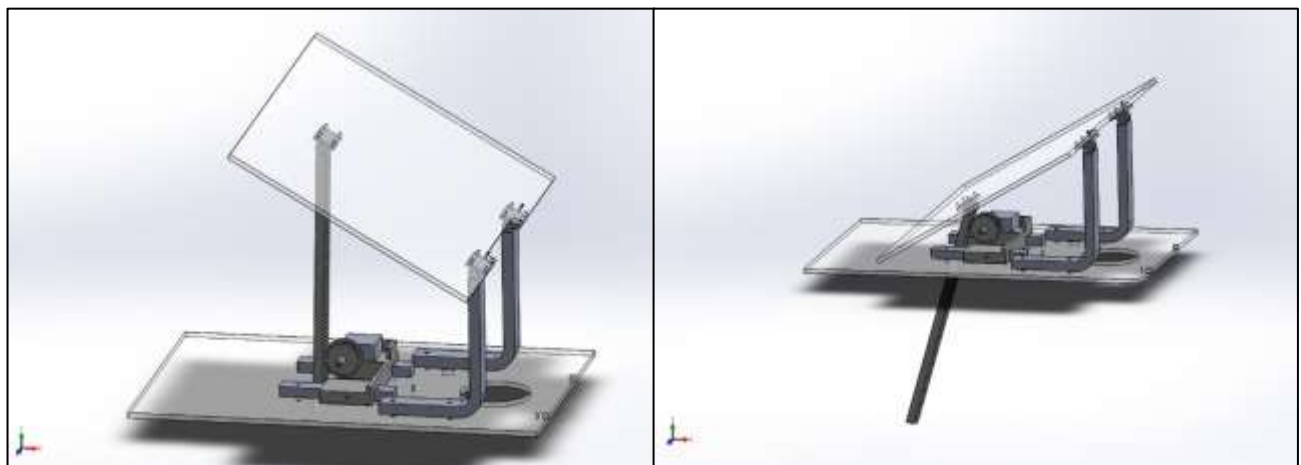
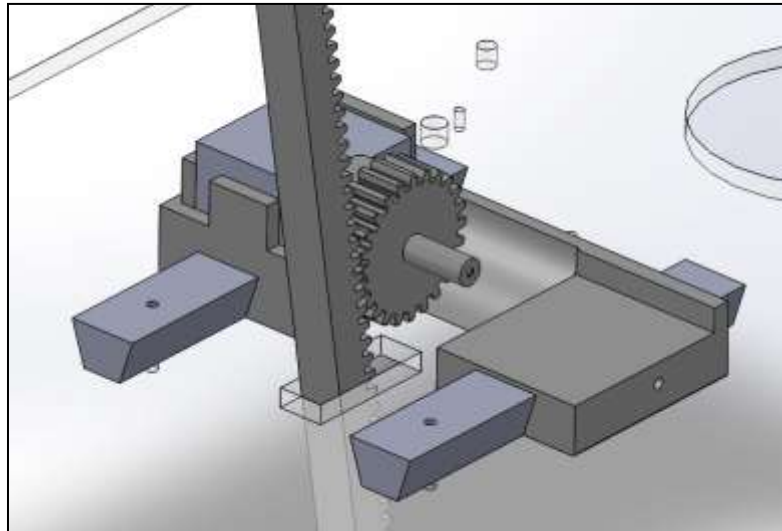

*Figure 33: Isometric View of Fixture*

in reference to the hardware from which the fixture was comprised of.



Building off of the previous design, the primary focus was on the rack and pinion, and making this sub assembly more robust. As seen in the first design iteration, the hole in which the rack would slide as the vertical angle changed did not permit any translational movement with respect to the horizontal plane. When the fixture was built this became an apparent problem. As the angle of the top platform of the fixture changed, the connection point between the top base and the rack would change with relation to the horizontal position of the racks hole. Since this connection was fixed, stresses were exerted on the rack as it flexed to compensate for the changes in orientation.



*Figure 34: Sliding Carriage Subassembly*

To accommodate this, a slot was put in place of the hole to allow for horizontal motion of the rack as the position changed. This reduced the stresses placed in the rack, keeping the integrity of the system intact.

Now that the Pinion had the ability to move, the rack and pinion needed to stay meshed throughout the vertical motion to prevent slippage. To account for this, a sliding mechanism was created to house the pinion. The sliding carriage allowed the pinion to move with the rack as it changed position. A spring was used to keep the motion of the rack and pinion unified and keep constant pressure between the rack and pinion, keeping the teeth meshed.

### Horizontal Motion

To complete the necessary horizontal angular motion required for the project, a bevel gear system was used to create the desired motion.

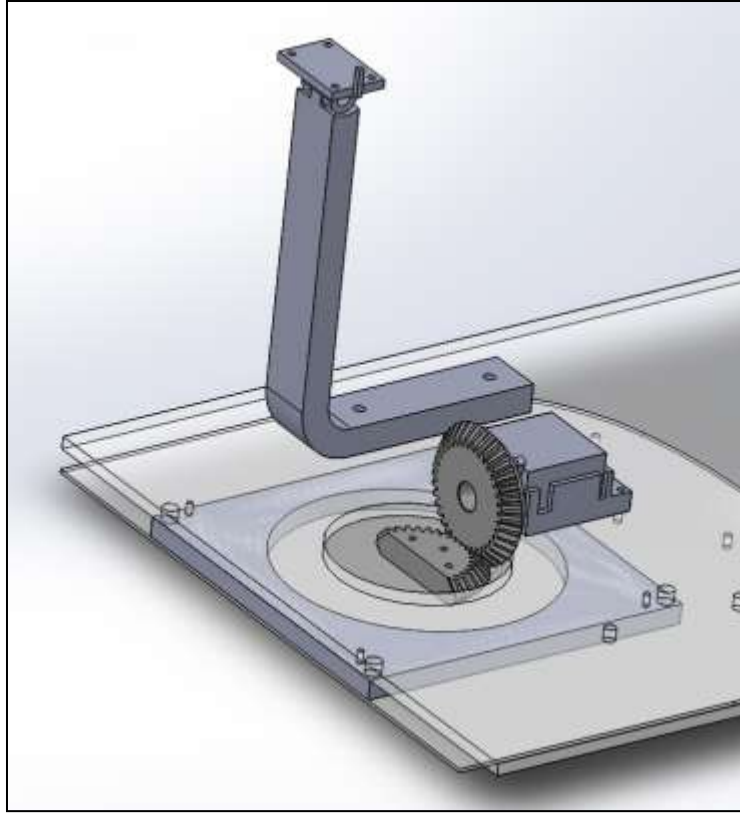

*Figure 35: Horizontal Motion Bevel Gears*

The gears were modified so they could be connected to a 180° servo. Bevel gears are highly efficient, and work well in applications that have low gear ratios and work at low speeds. Due to the ease of modification and implementation of these components, the gear system was incorporated.

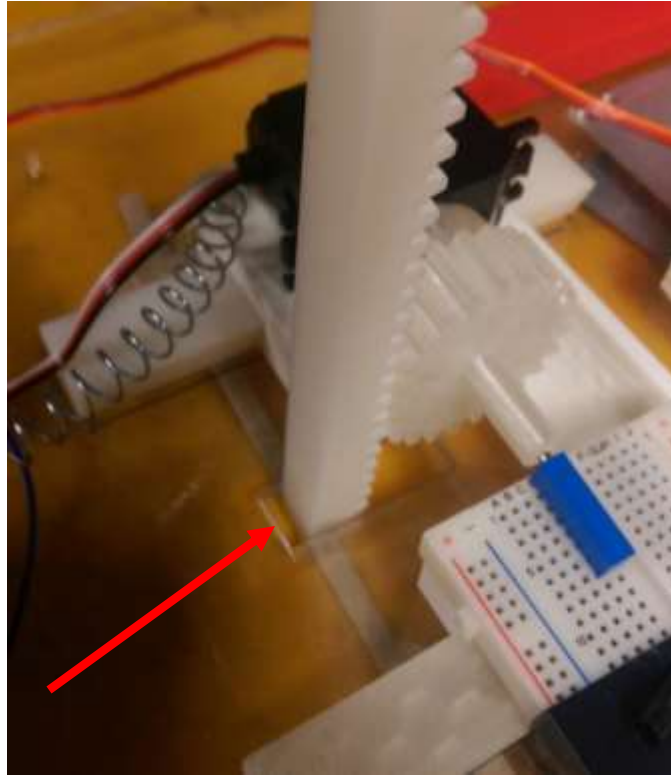

*Figure 36: Modified Assembly for Rack and Pinion*

## Prototyping

When prototyping began, issues arose that increased the difficulty in the use of this fixture. For the vertical angle components, it was apparent that problems would arise in the use of the system. For one, there were issues with the speed and distance which the rack would move up and down. Due to gravity, the rack would move much faster downward than it would upwards, and as a result, it was difficult to calibrate the system to stop at the correct angles. The servo used was not strong enough to keep the upward motion the same speed as the downward motion of the rack. To compensate, a rubber band was attached to the bottom of the rack. This resisted downward motion, and assisted upward motion, which helped mitigate this problem. However, since the weight of the system had such an influence on the angle achieved, the fixture would need to be calibrated to achieve the proper angle for each different product, which would be less practical than finding a new method of changing the angle in a way that was independent of the weight of the console being tested.

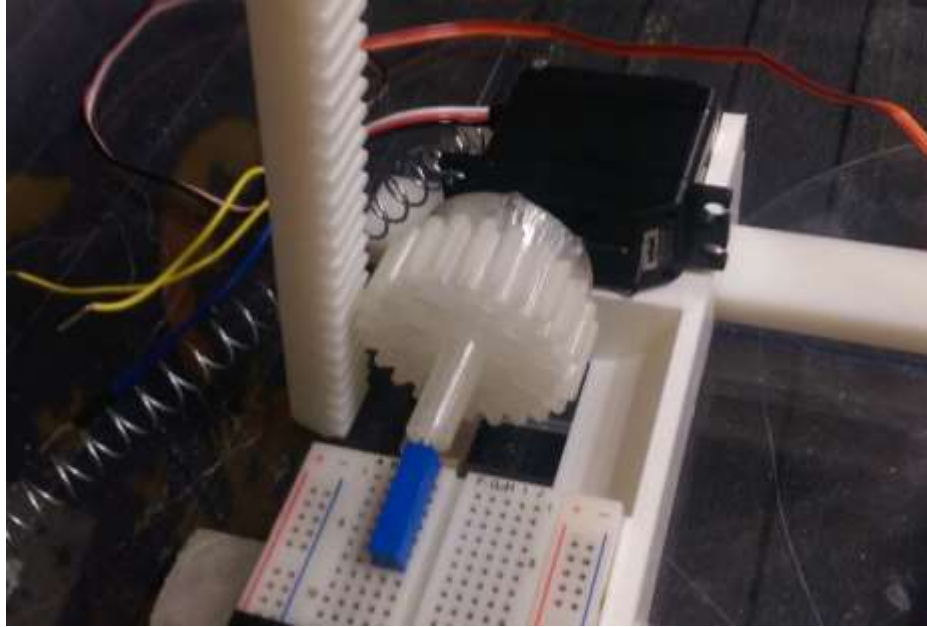

*Figure 37: Potentiometer and Pinion*

Using resistance as the method of setting the various test angles proved to be too unreliable. Due to the sensitivity of the potentiometer used, it was difficult to set an appropriate resistance range in which the desired angle could be obtained. This coupled with the speed at which the pinion spun the potentiometer made it nearly impossible to stop the system at desired positions, even when setting the range to  $\pm 100\Omega$  and setting the servo to a low speed.

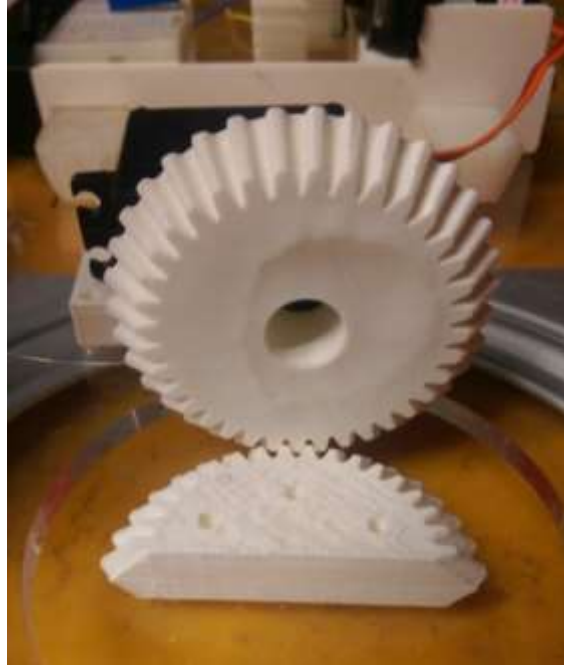

Figure 38: 3D Printed Bevel Gears

For the horizontal motion, there was trouble translating the rotation of the servo into the necessary horizontal motion of the platform. The primary reason for this is through the construction, of the assembly, rapid prototyped gears were utilized. Since these gears were made within a loose tolerance, the teeth did not mesh perfectly. This compounded with the fact that the servo only needs to rotate a small amount to set the proper angle resulted in large drops in efficiency, making the system difficult to run. It is also pivotal for bevel gears to operate at slow speeds in order to be most effective. Similar to the vertical rack and pinion assembly, the servo moved too fast for optimal results, even when slowed.

### Determining Electronics

In order to increase accuracy in aligning the angles and decrease the time it takes to run the test the team has determined these electronics that could help address these concerns.

The table below outlines the electronics, their role in the process, and why they were chosen

Electronic Component	Role in the Assembly	Why it was chosen
Arduino – IEIK UNO R3 Board ATmega328P	A computer that holds the code to tell each Servo when they need to rotate and how much they need to.	<ul style="list-style-type: none"> <li>- Ability to Operate Multiple Servos</li> <li>- Cheap</li> <li>- Easy to Program</li> </ul>
Servo - Generic High Torque Full Rotation	Rotates the Pinion to dictate the Vertical Angle of the Console Platform	<ul style="list-style-type: none"> <li>- Can lift large weights</li> <li>- Continuously Rotates</li> </ul>
Servo – Generic High Torque	Rotates the Gear to dictate the Horizontal Angle of the Console Platform	<ul style="list-style-type: none"> <li>- Can move large weights</li> <li>- 180 Degrees of Rotation</li> <li>- Easy to Program</li> </ul>

Table 11: Table of Electronics

## Using a Potentiometer

In order to operate the Generic High Torque Full Rotation Servo the Arduino must know when to start and when to stop the rotation. The start is done by the operator who clicks a button. The team has decided to use a potentiometer to determine when the servo will stop. The Arduino has been programmed to stop when the potentiometer reaches a certain resistance. The pinion, as seen in Figure 2, has a long axel that attaches to the multi-turn potentiometer. The potentiometer is wired back to the Arduino which reads resistance.

## Design Iteration 3

### Vertical Motion

After reviewing the second design both conceptually and as a prototype, the team decided to go a different way from the original rack and pinion concept. Maintaining consistent contact between the teeth of the rack and pinion gear was an issue in both previous prototypes. The reliance on a spring to keep constant pressure on both components for the vertical motion was variable, and the systems need to account for so many moving parts lead to gear slippage and large stresses on the rack at various vertical positions.

For these reasons, the team decided to design a simpler fixture- create a mechanism with as few degrees of freedom as possible. With this in mind, the team focused in on the idea of a gear system for both the vertical and horizontal motion. Vertically, a gear system with a ratio of 6:1 was used. Since maximizing torque in the system was one of the main issues in the previous designs, the large gear ratio would help increase the torque of the system and allow for more robust vertical motion.

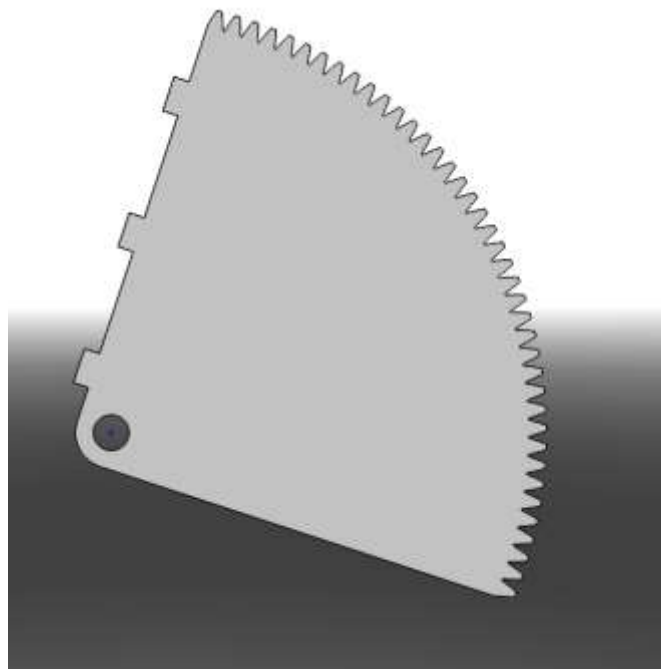

*Figure 39: Vertical Gear*

Since the fixture only needs to move a total of 60 degrees vertically, a quarter cutout of a six inch diameter gear was used as presented in the figure above. This allows for 30 additional degrees, acting as a tolerance to prevent the system from crashing at the outer limits of motion.

Ensuring the axis of rotation of this gear was perfectly aligned with the axis of rotation of the support hinges of the top platform was crucial. For this reason, 3 extrusions were incorporated into the design of the gear. These extrusions then fit into slots in the top platform which properly aligned the entire system. If the two axis of rotation were not properly aligned, as the gear system moved contact between the large and small gear would be lost, causing slippage and for the entire fixture to crash.

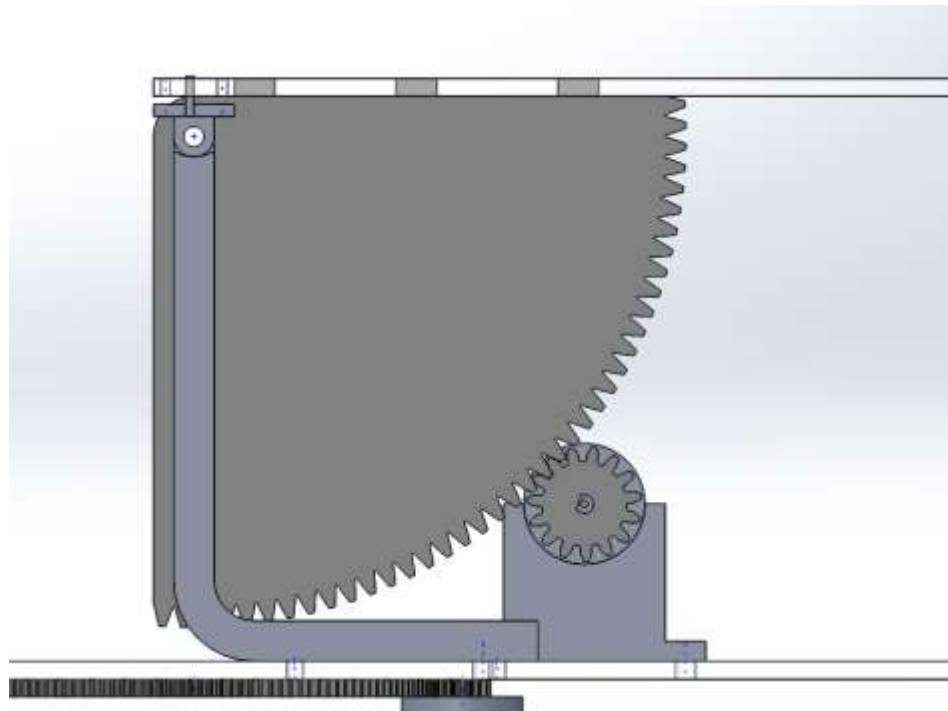
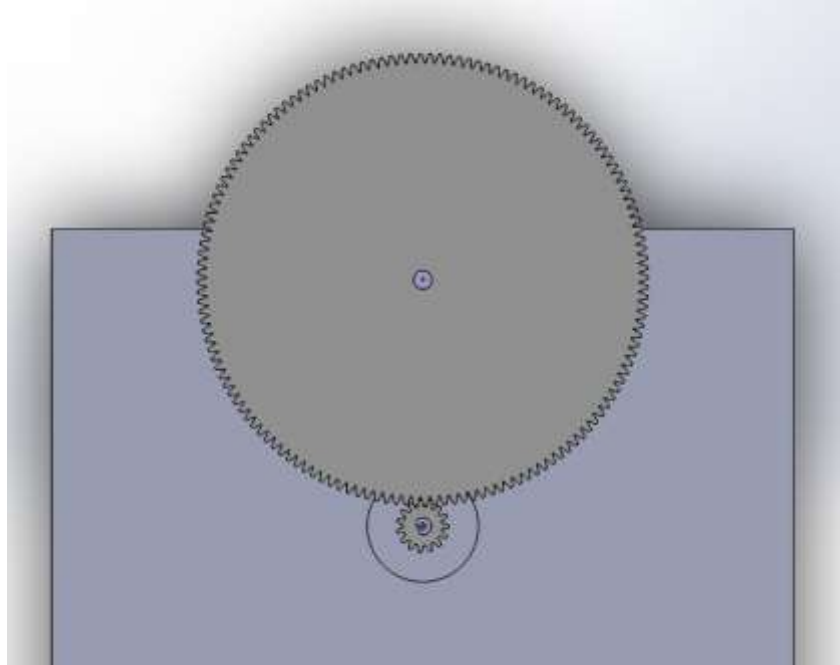

*Figure 40: Side View of Fixture Assembly*

The center of the small gear was positioned 1.95 inches above the bottom platform of the fixture. This was done to ensure that the small gear would be at a 45 degree angle relative to either edge of the large gear. The reason for this is that it would allow for a tolerance of 15 degrees in both the upward and downward vertical motion of the platform.

### Horizontal Motion

Through the prototyping done for the second design, it was clear that a new method of creating horizontal motion was needed for the new design. The Bevel gears needed much more torque than could be provided by the servos used in the previous design, and ensuring proper meshing of the teeth was difficult and lead to losses in torque as it was translated from the servo through the gears.



*Figure 41: Horizontal Motion Gear System*

Keeping the same concept used for the vertical motion, a gear system was used for the horizontal motion as well. This gear system utilized a 4 inch diameter gear along with a 0.71 inch diameter gear, again to give the system a large gear ratio to increase torque and thus the fixtures ability to complete desired motion. The large gear was fixed to the bottom face of the lower platform, and the center of rotation of this gear lined up with the center of the front edge of the top platform. Fixing the gear to this platform ensured that the entire fixture would rotate properly throughout the test, and aligning the center of the plate and gear made sure that the remote would always be facing the IR console.



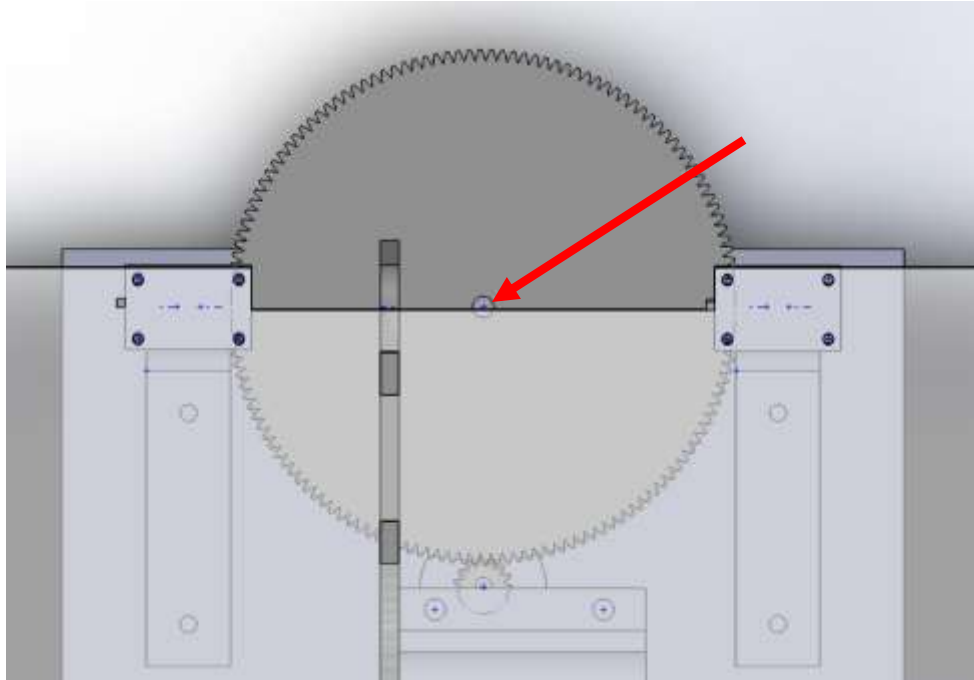

*Figure 42: Top View of Fixture Assembly*

### Motor Selection

Throughout the fixture prototyping process, looked at multiple options for different sources of motion. The team initially began with the use of continuous servo motors. These are small, inexpensive, and can produce the necessary levels of torque to move the system. The problem with these motors however is that when it comes to programming them, there is no way to simply program the servo to stop rotation based on a certain angle. For this reason, a potentiometer needed to be incorporated into the system as a way establishes reference points. The servo was programmed through the use of an Arduino, and the code written needed to look at certain values of resistance, and used these varying levels of resistance as check points for where testing angles would be located. The issue with this method was that due to the sensitivity of the potentiometer, getting the motor to stop spinning at the exact resistance was very difficult, and inconsistent.

Due to the problems faced through the use of servos, the team looked into the use of DC motors. The benefits to using these motors as opposed to using servos is that these motors are easier to code and therefore easier to incorporate into the testing system, and they also have much more torque. These motors are able to count a specified number of pulses per rotation. These with the ability to count pulses, the team can essentially relate pulses to certain angles, by telling the motor to stop running when a defined number of pulses have been reached. Once this baseline code has been written, calibration to find the specific angles was required.

Electronic Component	Role in the Assembly	Why it was chosen
Arduino Compatible Mega 2560 R3 Microcontroller Board	A larger computer that holds the code to tell each Motor when they need to rotate and how much they need to.	<ul style="list-style-type: none"> <li>- Ability to Operate Multiple Motors</li> <li>- Inexpensive</li> <li>- Easy to Program</li> </ul>
Arduino Motor Shield	An attachment to the Arduino that keeps the Arduino and motors from getting hot	<ul style="list-style-type: none"> <li>- Mitigates any overheating</li> <li>- Inexpensive</li> </ul>
12V Low Noise DC Motor 146RPM w/Encoder	Rotates the Gear to dictate the Horizontal Angle of the Console Platform	<ul style="list-style-type: none"> <li>- Large Gear Ratio &amp; High Torque</li> <li>- Continuous Rotation</li> <li>- Coded with Encoder Pulses or Timing</li> </ul>
12 V Metal Gear motor 365rpm w/Encoder	Rotates the Gear to dictate the Vertical Angle of the Console Platform	<ul style="list-style-type: none"> <li>- Large Gear Ratio &amp; High Torque</li> <li>- Continuous Rotation</li> <li>- Coded with Encoder Pulses or Timing</li> </ul>

Figure 43, shows the 12 Volt DC Motor chosen to move the horizontal motion.



Figure 43: 12 Volt DC Motor with Encoder

### Prototyping

The team was able to build a successful prototype of this design. The prototype began with the construction of a 15 inch by 15 inch by 15 inch box. This box was responsible for housing both the motor that drove horizontal rotation of the fixture and the Arduino, breadboard, and all necessary wiring components that made automation of the fixture possible. This can be seen below in Figure 44.



*Figure 44: Console Fixture Electronics Housing Box*

From there, the necessary gears and top platform were laser cut out of 0.22 inch extruded acrylic. It was important to laser cut these components because the integrity of the entire system working was based off of the two gear systems working properly, and the entire system aligning to ensure proper rotation.



*Figure 45: Laser Cut Gears*

Once the necessary components were laser cut, assembly of the prototype was able to be completed.



*Figure 46: Console Fixture Prototype 3*

The Cinemate console was placed on it and different angles were tested. While the Vertical Motor struggled to hold the weight of the console the horizontal motor worked very well. The qualification for the Horizontal Motor can be found in Appendix E. Figure 47 shows the fixture holding the console at  $-20^\circ$  horizontal and  $20^\circ$  vertical.



*Figure 47: Fixture Holding Console*

Once the physical prototype was built, coding the motors was the next step to complete. Due to time restraints and the team's level of knowledge of Arduino code, the motors were coded to run based on time, rather than counting pulses in the motor as it rotates. For the horizontal motor, this worked well, and the team was able to test the consistency of the fixtures horizontal rotation. For the vertical aspect of the fixture however, the team was unable to get the motor encoders break function to work. For this reason, it was difficult to keep the top platform at the desired angles.

## Calculations

This section addresses the calculations that were run to determine the functionality of the second and third design iteration.

### Iteration 2: Vertical Motion

It is important to calculate an estimated maximum weight that the fixture can hold and move. This can be done through a moment analysis of the design.

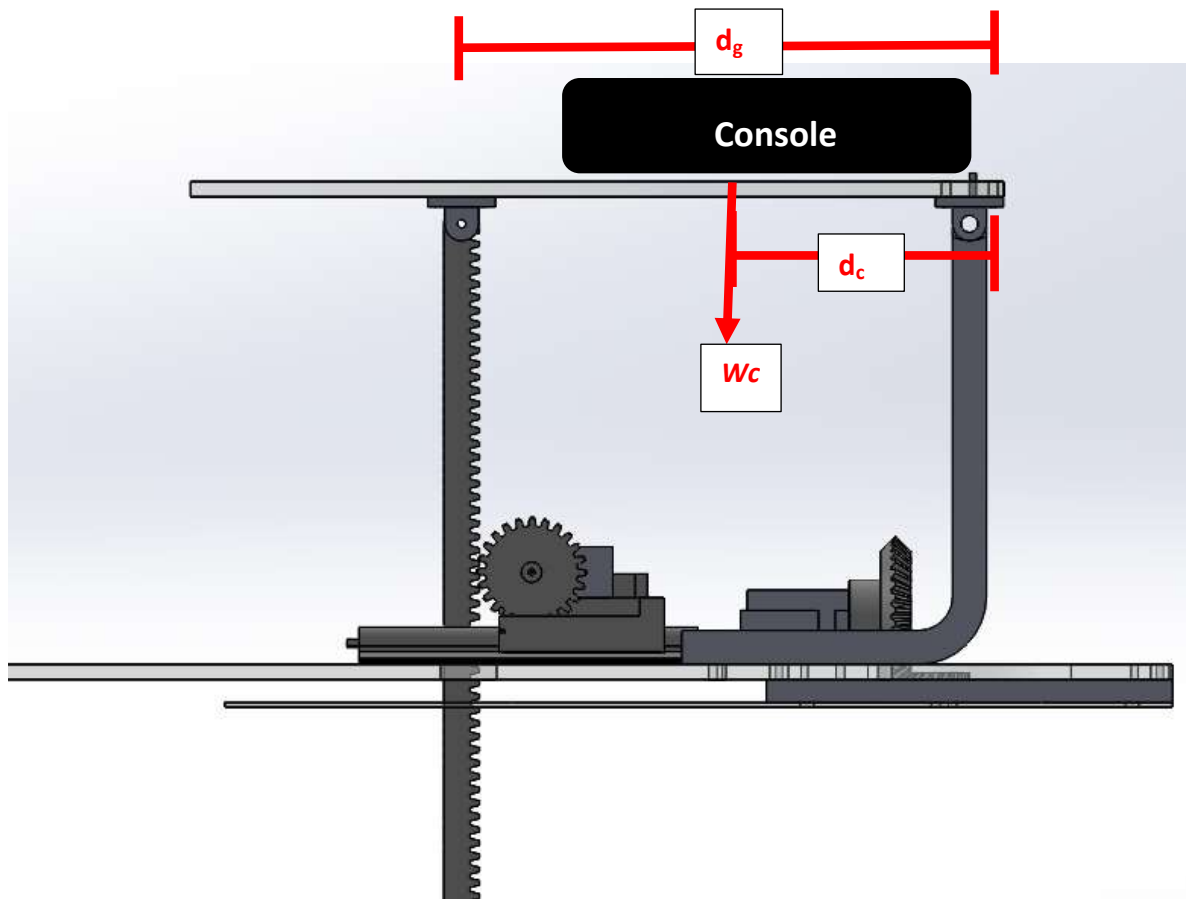

Assuming the console can be represented by a point load located at the center of console, the following equations can be used. The equation below will show the weight limitations for the vertical rack and pinion. Since the test fixture for the console will provide both vertical and horizontal motion, it will be necessary to calculate the maximum weight for horizontal rotation as well. Based on these two values, value of the smallest weight will be the maximum weight for each specific design, since the fixture will need to successfully rotate the console both vertically and horizontally.

Starting with the basic equation below, the weight of the console multiplied by the distance between the position of the weight and the vertical rack and pinion is equal to the torque of the servo motor divided by the radius of the attached gear and multiplied by the distance between the gear and weight.

$$W_{cmax}d_c = \frac{T}{r_g}d_g$$

Where

$W_{cmax}$  = Maximum weight of the console,

$d_c$  = Distance to the console = 6 in,

$T$  = Torque of the servo = 70oz \* in,

$r_g$  = Radius of the gear = 0.75in, and

$d_g$  = Distance to the gear = 9in.

Manipulating this equation, the maximum weight of the console is calculated:

$$W_{console\ max} = \frac{T_{servo}}{r_g} * \frac{d_g}{d_c} = \frac{70oz * in}{.75in} * \frac{9in}{6in} = 140oz = 8.75lb$$

This value represents the maximum load which this design can successfully rotate vertically.

### **Iteration 3: Vertical Motion**

Although the design of the prototype changed, the same core equations were used to evaluate the final design. Using the values associated with the new prototype, the calculations can be seen below.

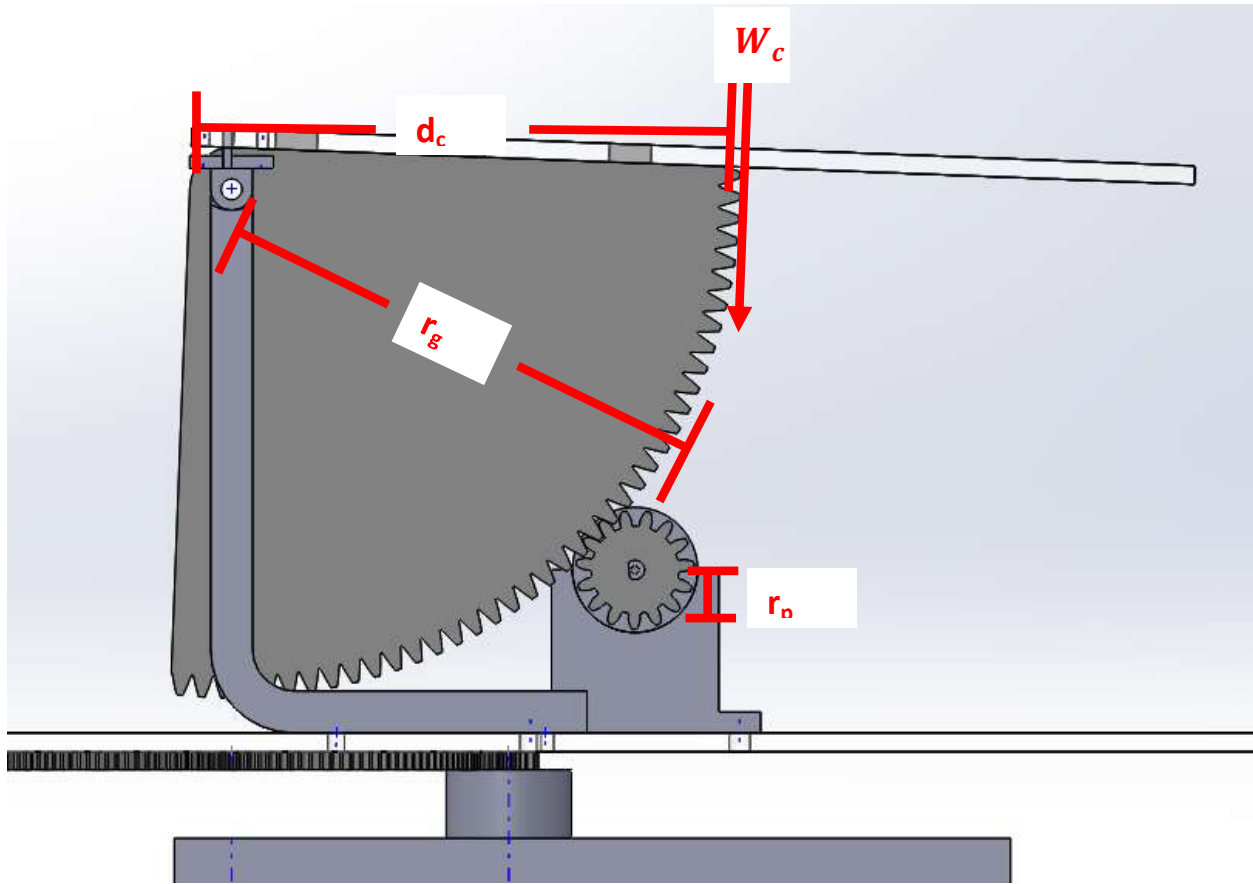

Beginning with the equation below:

$$W_{cmax} = \frac{T_{vmotor}}{r_p} * \frac{r_g}{d_c}$$

Where:

$T_{vmotor}$  = Torque of the vertical motor = 139oz \* in,

$r_p$  = Radius of the pinion = 0.75in,

$r_g$  = Radius of the gear = 6in, and

$d_c$  = Distance to the console = 6in.

Using the known values of distance and torque for the given design, the maximum weight of a console that the system can successfully move vertically is displayed below:

$$W_{console\ max} = \frac{139\ oz * in}{.75in} * \frac{6in}{6in} = 185.33oz = 11.7lbs$$



There was an increase in total weight that could be moved vertically from the second to third design iteration. This is due to both the increased strength of the motor used, as well as the large gear ratio used in the system.

## Prototype of Remote Fixture

When creating a fixture for the remote and LED segment of the test, there were a few notable variables to consider when designing this fixture. In regards to the test, it is necessary to have both a working remote as well as a bare infrared transmitter, as these qualify both the remote and console respectively. Integrating both test components into the design in an operator friendly manner with as little fixture manipulation as possible was imperative.

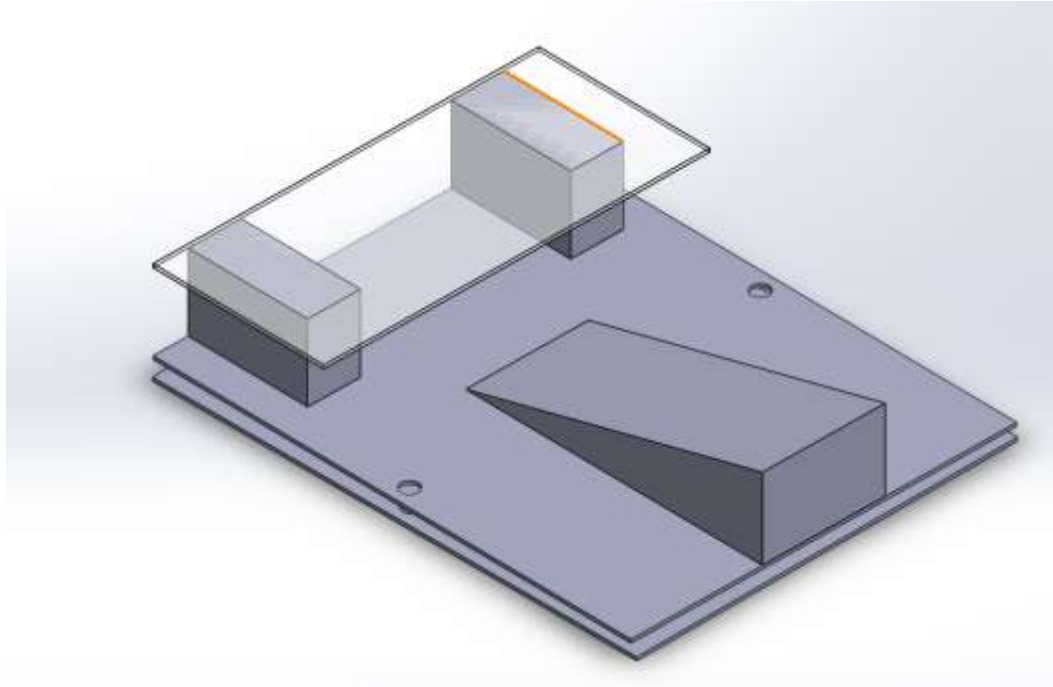

*Figure 48: Remote and IR Blaster Fixture*

As seen in Figure 48, there is a triangular platform. This platform has an angle of 15 degrees, which will account for the 15 degree offset of the LED already in the remote.

Behind the remote platform on the testing fixture is an acrylic platform. This platform will be used to hold the bare IR transmitter for the console-qualifying portion of the test. To ensure that this fixture can be used for both tests, the platform is offset to be the same height as the remote height. This eliminates the need to adjust the height of the fixture during the test, thus decreasing time and removing the need to reassure the system is properly aligned.

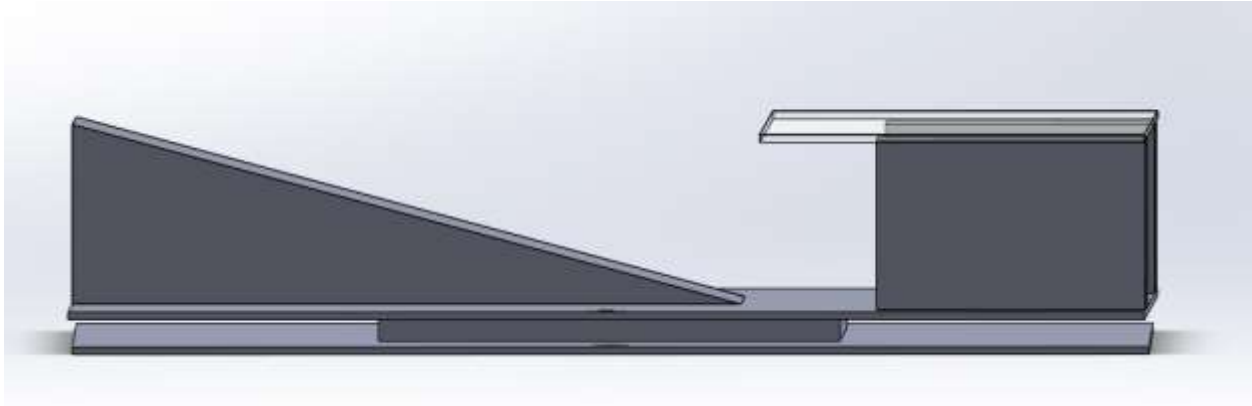

*Figure 49: Remote and IR Blaster Fixture Side View*

To promote ease of use for the operator, a Lazy Susan was incorporated to help spin the fixture between the remote and IR blaster. Displayed in Figure 49 is a side view of the fixture. Between the top and lower base is the Lazy Susan mechanism, and this is what allows for the free rotation of the fixture.

There are pin holes on both the top and lower base, seen in Figure 48, and these will help ensure alignment in the system as the operator changes between the different test components.

Overall, this fixture allows for the qualification of both the remote and console, while removing the need to adjust any other test components, and effectively holding all necessary equipment. In the future, Bose could consider creating interchangeable remote platforms that house specific remotes, to further increase confidence in the test and alignment of the different components.

Figure 50 below, displays the completed prototype for the Remote and bare IR transmitter.

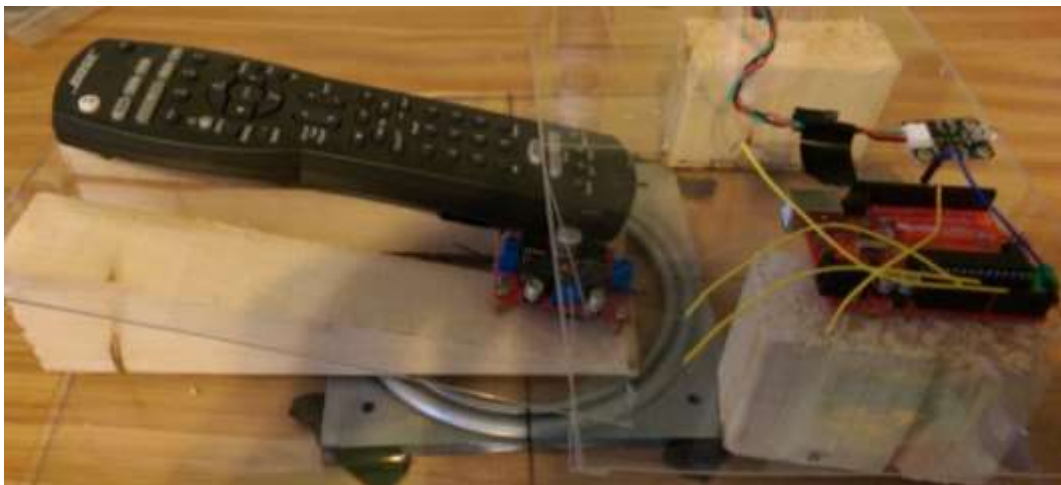

*Figure 50: Remote and IR Blaster Prototype*

## Qualification of Fixture

In order to qualify how well the testing fixture is able to repeatedly move the console to the desired orientation, multiple trials of setting the console to the appropriate angle were completed and this data was used to establish the degree of repeatability for both the older and new fixture. For this particular test, only the horizontal angle was able to be used, since the team could not code the motor encoder to utilize its brake function.

An Android App called Compass, was able to measure the horizontal angle based on the same technology as digital compasses. This app was used for both the preliminary fixture design and the final design. The team went through the procedure for changing the horizontal angle to simulate the test being conducted three times. Finding the difference between the desired angle and the angle read by the compass app, the team was able to calculate the statistics to determine how well the fixture could produce the angle. The raw data for each test can be found in Appendix E.

The preliminary testing fixture has a 95% confidence that the actual angle is within 0 and +3 degrees of the desired, which shows that the old fixture skews the angle slightly higher than wanted and has a range of 3 degrees. This shows that the previous design consistently sets the angle too high, but in order to see how repeatable the fixture can move to the set angle is the standard deviation. For the horizontal angle of the preliminary design, the standard deviation is 4 degrees. An angle deviation up to 3 degrees is too large since the testing interval is set to 10 degrees.

Using the data found from the new fixture, which can be found in Appendix E, the test operator can be 95% confident that the actual angle is within the range of -1 and 0. This range may be skewed to the negative side, but this could be compensated for in the programming, after knowing this information, the code can be easily manipulated to have the motor move the fixture slightly less. The more important statistic is that the standard deviation is only 1, a marked improvement from the 4 of the preliminary fixture. This great reduction in standard deviation now provides confidence that the test will yield consistent parameters from operator to operator, and between different products.

## Recommendations

The main element of the test that needs to be improved is the code used to run the motors. Currently the code does not utilize the encoder to its full potential. The motors have 663 pulses per revolution, and these pulses could be used to ensure the fixture is within 0.54 degrees of the desired angle. Incorporating this function as opposed to just using time would increase confidence in the motors ability to reach desired angles. The motor encoder also has a brake function. This function stops the weight of the console from reversing the motor while it is stopped at each angle interval, thus preventing any changes in position. By using time to set angular position and not using the breaking function, the motor is susceptible to changes in position throughout the test. Both of these should be very possible for someone familiar with coding Arduinos.

In the future, teams working on this project should look into finding a method of tapping into the components of the console, as a way to directly read whether the console was able to receive the signal or not. This would remove any difficulty in recognizing a success, which is currently determined by visually seeing the light turn on. This light may not be incorporated into every home entertainment design, so finding a method to electronically verify a success would be beneficial to future products. It would also make this procedure a step closer to being completely automatic.

Another component that could be valuable for future testing is the addition of an IR blaster that can replicate a signal from the remote, but instead of repeating the signal while the button is pressed, only send it once. This would ensure that the test operator is only sending the desired number of signals, which would further reduce variation.

If the IR blaster is unable to achieve the anticipated result, finding a way to press buttons on the remote automatically could provide a similar result. Solenoids are devices similar to electromagnets. These are composed of a large coil of copper wire, and a metal cylinder in the center, called an armature. When current flows through the wire, a magnetic field is produced around the wire, and this magnetic field allows the armature to retract, closing the gap between the cores. Solenoids are inexpensive, and one of their primary functions is triggering, which is exactly the application needed for this experiment. A solenoid could be programmed to extend its piston for a specified length of time, equivalent to one signal, which will increase the consistency of the test results.

For the console fixture, it could be beneficial to modify the design of the gear subassembly responsible for the changing of the vertical angle. A second gear connected to the console platform could be incorporated into the design by placing both gears on the sides of the base. This would make the fixture more stable and allow heavier products to be tested. Moving the gear would also allow the gear to be larger, which would either allow a smaller motor to be used, or increase the maximum console weight even more.

For the horizontal motion component, the gear could be cut in half. Based on the range of angles that must be met for this test, there is no need to have a full gear. This would decrease the amount of material needed to build the fixture, and make the assembly less expensive.

Another element of the test that would increase accuracy is a track that aligns the console and remote fixtures. Using this track would ensure perfect alignment of the components, and also ensure the correct separation between test components. Along with the increased accuracy and consistency of the test, test time would decrease because this would eliminate the tedious alignment using lasers and make setting up for the test simpler.

This entire process could be autonomous by adding a few components to the test. With the ability to verify whether the signal was successfully received or not and knowing that only one signal is sent out at a time are integral to this goal. After having those two components it would be a simple task to compare the number of signals sent to the number successfully received and then move to the next orientation. Ideally, this would only require the test operator to start the test and then read the outputted spreadsheet. Using this method would allow one test operator to conduct multiple tests at the same time, which would significantly decrease the required man-hours and increase the confidence that the test results accurately reflect the design.

## Appendix

### Appendix A

#### Interview Questions

##### Questions for Electrical Engineers

1. Do you see problems with adding the resistor to simulate distance to the test?
  - a. Have you ever compared results from testing with resistance to simulate distance and true distance between receiver and remote?
2. What do you believe is the most relevant data in terms of testing the quality of the remote when in use?
3. What equipment do you use to record the transmitted signal and what do you measure?
4. In terms of consistency and repeatability, what do you see as possible additions to the current test?
5. Does the process differ for different remotes for different Bose products
  - a. Do the different manufacturers get separated when testing and recording test data?
6. Is it possible to reprogram the remote so it only sends out a certain number of signals when pressed, instead of repeating while pressed?
  - a. If so, How and would it be a realistic addition to the test?
7. Why does the signal become difficult to pick up when the power supply is less than 2.6 Volts?
8. How does the console recognize the signal in order to perform the desired task?
9. Does the amplitude of the signal affect the ability of the console to recognize it?
10. Why is the IR LED angled 15 degrees down?

##### Alignment

##### Questions to Engineer with Test Experience

1. What is your current test process?
  - a. How long does the current testing take?
  - b. How many people are involved with a typical test session?
2. Can you describe in more detail the data that you record?
3. What do you do with the data you record?
4. Do you see any areas of improvement for the test in its current state?
5. Are there any environmental challenges faced through the test?
  - a. Do you take this into account when testing or recording data?
6. Are there any changes you would like to see in the future for this testing process?
7. What potential facilities do you have for testing?
8. Do you take into account the -15 degree angle of the IR LED when aligning the remote and the console?
9. There are two different manufacturers of the remote. Have you ever found a difference between the performances of these two?

### **Questions to Test Technician**

1. What is your current test process?
2. How do you ensure that the remote is directly in line with the receiver?
3. How long does the current testing take?
4. How many people are involved with a typical test session?
5. Where does this test take place, and are there any other potential sites?
6. Can you go into more detail on the data that you record?
7. What do you do with the data you record?
8. Is there any specific program that you use or recommend for us to use that helps collect and record data?
9. Do you see any areas of improvement for the test in its current state?









### **Questions for User Experience / Marketing Team**

1. What role do you play in the testing process for IR Remotes and Receivers?
2. If there are any, what are the qualifications that need to be met for Bose remotes from a user experience perspective?
3. The average sized living room of a larger home is 18' by 13' do you think that this is representative of the customers using Bose remotes?
4. What information regarding Bose remotes do you market to the customer?
  - a.) From a marketing perspective, what information is most important in helping you when it comes time to sell the product?
5. Are there any common customer complaints regarding Bose Remotes?
6. Is there any data that we could collect that would help market the product?



## Appendix B

The following procedure is the procedure the team used to experimentally simulate the distance.

Simulating the Distance Test Procedure				
Step	Procedure	Time (min)	Notes	Picture
1	Lay and secure tape measure at 10 feet in an open space.	2	Make sure tape measure is straight	
2	Place receiver tripod at one end. Ensure the face of the receiver platform is flush with the edge of the measuring tape	3		
3	Repeat Step 2 with Transmitter tripod. Ensure the face of the transmitter is flush with 10 feet marker on measuring tape.	3		
4	Place a laser and level on the receiver platform. Adjust platform until it is level and adjust laser with protractor until it is pointed at 90 degrees.	3	Making sure the laser is oriented at 90 degrees will ensure the remote and console are lined up appropriately.	
5	Line the remote up with the laser ensuring that the laser can be seen in both the front and back of the remote	3	The laser must be seen at both the front and back of the remote to ensure that it is properly aligned and will yield the most accurate test data	
6	Place the console on the tripod stand. Make sure the console is flush with the front face and symmetrically in the center.	1		
7	Connect the wires which replace the resistor, R2, and the batteries into a bread board. Attach a 1K potentiometer and buck boost converter into their respective spots on the board	5	Follow the Picture for easy setup.	
8	Connect two wires to the other side of the potentiometer, and hook these wires up to a multimeter to read the resistance as it is changed	1		

## Appendix C

### Bose Infrared Reception Testing Standard Operating Procedure

**Operator:** 1 Test Technician

**Timing:** <4 Hours

**Materials Needed:**

Remote Control
Console
Package of Jumped Wires
Solder and Solder Iron
100Ω Potentiometer
Buck Boost Converter
Breadboard
Transmitting Fixture (including built in Arduino Uno)
Console Fixture (including built in motors, Arduino Mega, and Motor Shield)
Alignment Laser
2 Flat Tables or Surfaces
Measuring Tape
Oscilloscope (with at least two channels)
Multimeter
Bose Homegrown Photodiode receiver

### Setup

1. Identify the remote control that you will be using. This will be the remote that will need to be carefully modified.
  - a. Break the remote open so you can see the PCB inside of it.
  - b. Identify the Current Limiting Resistor (R2) to the LED and remove with the Soldering Iron.
  - c. In its place solder in two wires to each side of the circuit as seen below.

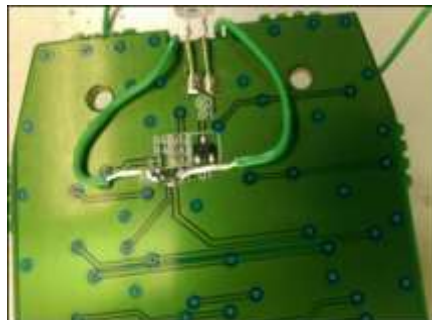

- d. At the bottom of the remote on the power terminals solder in two color coated wires in order to attach a consistent power supply other than batteries. This can be seen below:



- e. With the wires in place, put the plastic converting and button pad altogether and attach the power terminal wires to the buck boost converter and the R2 wires to the breadboard as shown below:



- f. In order to read out the value of the potentiometer attach separate wires to the other side of the potentiometer to read out to a multimeter.

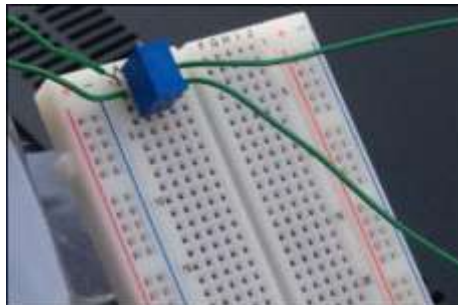

- g. This setup is now completed and can be put on the Transmitting Fixture



2. Place the console product on console test platform
  - a. Make sure product is aligned in the center of the platform.
3. Measure the height of the console off the ground. This must be greater than 2 feet and 8 inches.
4. Move the remote fixture 10 feet away from the console fixture. Ensure it is at the same height and use lasers to ensure proper alignment to the console.
5. Rotate the transmitting fixture to have the Remote Control Facing the console.
6. Before beginning the test, the console fixture must be calibrated to take into account the weight of the console.
7. An app, called Compass, was used to determine the timing on the horizontal motion of the fixture and a level app was used for the vertical angle.
8. Once this was established the procedure could move forward to the Qualifying portion.

### **Qualifying**

9. Place the remote control in Bill Bitter's Photodiode tester which is hooked up to an oscilloscope.



10. Make sure that the remote is transmitting properly at its expected resistance. The expected graph would look similar to the one below:

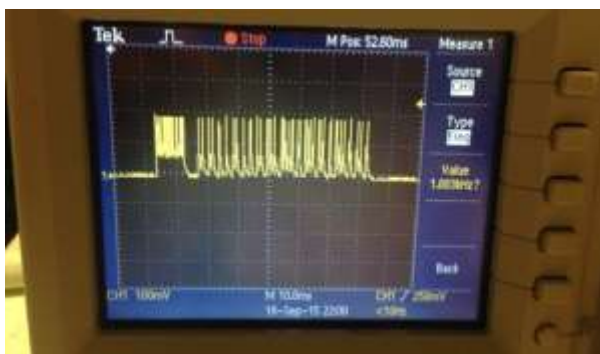

11. Using the oscilloscope, change the resistance to 2Ω, 8Ω, 16Ω, 32Ω, 64Ω, 128Ω. Record the Pk – Pk Voltage that shows up on the Oscilloscope and graph it in this table

Resistance (Ω)	Voltage (V)	Power (mW)	Distance (Ft)
2 Ω			
8 Ω			
16 Ω			
32 Ω			
64 Ω			
128 Ω			

12. Knowing 2Ω (may vary per remote) is the normal value of R2, this is the value to relate back to.

a. Use the equation:  $Distance\ Factor = \sqrt{\frac{(Output\ Power\ at\ Varied\ R2)}{Output\ Power\ of\ Unmodified\ Remote}}$

13. This Distance Factor is to be multiplied by 10 feet (the distance the remote is from the receiver) that value will give you the simulated distance that each power is giving you.
14. This will now be used to determine an equation that you can use to simulate the distance so that the remote will be able to remain fixed for the duration of the test.

### Testing

15. The operator must choose the test that they are planning to use. The Expected Maximum Test is much more in depth and time intensive, while the Baseline Test gives the general expectations of the signal in a standard room.
16. Use the potentiometer that is wired in place of R2 to adjust the resistance to the specified value for all test points.
17. For the Expected Maximum Test the template below will be used.

		Horizontal Angle, $\alpha$ (Degrees)								
		-40	-30	-20	-10	0	10	20	30	40
Vertical Angle, $\beta$ (Degrees)	-30	0	0	16	18	33	22	17	0	0
	-20	0	11	53	77	83	80	63	10	0
	-10	10	33	80	90	95	102	72	35	10
	0	14	62	91	106	98	112	82	50	11
	10	10	48	86	101	89	92	85	37	14
	20	0	29	76	89	94	92	71	25	0
	30	0	0	24	50	59	44	21	0	0

18. Send signals to the console at the angles required. Adjust the resistance of the potentiometer until the console no longer receives 8 of the 10 signals.
19. Record the maximum resistance.
20. Use the distance factor relationship to determine the distance that is being simulated and enter into the graph.
21. The procedure to measure all of these points is to adjust the vertical angle, then do each corresponding horizontal angle before adjusting the vertical angle again.
22. The other option is to do the Baseline Test. The template for this test can be seen below.

		Horizontal Angle ( $^{\circ}$ )						
		30	20	10	0	-10	-20	-30
Vertical Angle ( $^{\circ}$ )	30							
	20							
	10							
	0							
	-10							
	-20							
	-30							
		30	50	70	70	70	50	30
Distance Simulated (ft)								

23. Send 10 signals to the console to test reception for the console for  $0^{\circ}$  vertical in the vertical angle. Record how many were received.
  - a. The signals are sent by pressing the Volume Up or Down button on the remote. You can see if they are received by the blinking light on the console

24. Change the vertical angle to the specified angles of  $10^\circ$ . Repeat the previous step to send signals and record data
  - a. This is done through the use of a button. This button will allow the Arduino to change the horizontal angle and change the vertical angles before changing horizontal angle again.
25. Repeat steps 6 and 7 for the remaining vertical angles,  $20^\circ, 30^\circ, -10^\circ, -20^\circ, -30^\circ$ . Record results
26. Change the horizontal angle of the console fixture to  $10^\circ$ 
  - a. Need to explicitly know how to change the horizontal angle and write it here
27. Change the resistance of the remote to the specified resistance correlating to the given horizontal angle.
28. Send 10 signals to the console to test reception for the console for  $0^\circ$  vertical in the vertical angle. Record how many were received.
29. Change the vertical angle to the specified angles of  $10^\circ$ . Repeat the previous step to send signals and record data
30. Repeat steps 9 and 10 for the remaining vertical angles,  $20^\circ, 30^\circ, -10^\circ, -20^\circ, -30^\circ$ . Record results
31. Change the horizontal angle to  $20^\circ$
32. Change the resistance of the remote to the specified resistance correlating to the given horizontal angle
33. Send 10 signals to the console to test reception for the console for  $0^\circ$  vertical in the vertical angle. Record how many were received.
34. Change the vertical angle to the specified angles of  $10^\circ$ . Repeat the previous step to send signals and record data
35. Repeat steps 10 and 11 for the remaining vertical angles,  $20^\circ, 30^\circ, -10^\circ, -20^\circ, -30^\circ$ . Record results
36. Change the horizontal angle to  $30^\circ$
37. Change the resistance of the remote to the specified resistance correlating to the given horizontal angle
38. Send 10 signals to the console to test reception for the console for  $0^\circ$  vertical in the vertical angle. Record how many were received.
39. Change the vertical angle to the specified angles of  $10^\circ$ . Repeat the previous step to send signals and record data
40. Repeat steps 10 and 11 for the remaining vertical angles,  $20^\circ, 30^\circ, -10^\circ, -20^\circ, -30^\circ$ . Record results
41. Change the horizontal angle to  $-10^\circ$
42. Change the resistance of the remote to the specified resistance correlating to the given horizontal angle
43. Send 10 signals to the console to test reception for the console for  $0^\circ$  vertical in the vertical angle. Record how many were received.
44. Change the vertical angle to the specified angles of  $10^\circ$ . Repeat the previous step to send signals and record data
45. Repeat steps 10 and 11 for the remaining vertical angles,  $20^\circ, 30^\circ, -10^\circ, -20^\circ, -30^\circ$ . Record results
46. Change the horizontal angle to  $-20^\circ$

47. Change the resistance of the remote to the specified resistance correlating to the given horizontal angle
48. Send 10 signals to the console to test reception for the console for  $0^\circ$  vertical in the vertical angle. Record how many were received.
49. Change the vertical angle to the specified angles of  $10^\circ$ . Repeat the previous step to send signals and record data
50. Repeat steps 10 and 11 for the remaining vertical angles,  $20^\circ, 30^\circ, -10^\circ, -20^\circ, -30^\circ$ . Record results
51. Change the horizontal angle to  $-30^\circ$
52. Change the resistance of the remote to the specified resistance correlating to the given horizontal angle
53. Send 10 signals to the console to test reception for the console for  $0^\circ$  vertical in the vertical angle. Record how many were received.
54. Change the vertical angle to the specified angles of  $10^\circ$ . Repeat the previous step to send signals and record data
55. Repeat steps 10 and 11 for the remaining vertical angles,  $20^\circ, 30^\circ, -10^\circ, -20^\circ, -30^\circ$ . Record results.
56. Enter all of the data into the template and examine the results.



## Appendix D

Prototype 3 Bill of Materials		
Item	Quantity	Purpose
12 Inch 2x4	8	The top and bottom structure of the box that creates the base
8 Inch 2x4	4	Makes up the vertical components of base.
L Bracket	10	Used to hold the box together and hold the 13inch diameter quarter gear to console base
15" x 15" .5" Inch Plywood	1	Supports the whole fixture and secures the horizontal motor
.5" Diameter Gear	1	Attached to the Horizontal Motor
6" Diameter Gear	1	Attached to Acrylic Fixture Base to rotate whole fixture in the horizontal angle
12V Low Noise DC Motor 146RPM w/Encoder	1	Horizontal Motor
3" 1/4" Diameter Bolt	1	Center of Rotation for the horizontal motion of the fixture
1/4" Nut	2	Holds the bolt securely in place through the plywood for the top base
Acrylic Fixture Base	1	Base that the console is mounted onto
12 V Metal Gear motor 365rpm w/Encoder	1	Vertical Motor
Vertical Motor Fixing	1	Secures the Vertical Motor to the Acrylic Base
13 Inch Diameter Quarter Gear	1	Used to reach the vertical angles. Attached to the consoles fixture
1 Inch Diameter Gear	1	Attached to Vertical Motor
Console Base	1	Acrylic sheet that hold the console on top.
console Lift	2	Provides ample space for the console base to raise and lower to necessary angles.
Hinge	2	Allows the console base to freely rotate the vertical angle
Arduino Compatible Mega 2560 R3 Microcontroller Board	1	Used to translate code from the Arduino program to the motors
Arduino Motor Shield	1	Used to protect the motors and Arduinos from getting too hot
Jumper Cables	16	Used to connect the Arduino to the motor
Felt Pads	4	Used to allow easier sliding in the horizontal motion
Slider Boards	2	Plywood with Acrylic on top that creates an easy sliding surface for fixture.

## Appendix E

This data is the result of qualifying the fixture's Horizontal and Vertical accuracy.

Original Horizontal Angle Repeatability		
Desired Angle	Actual Angle	Difference
0°	2°	-2°
10°	11°	-1°
20°	19°	1°
30°	29°	1°
40°	37°	3°
0°	4°	-4°
-10°	-7°	-3°
-20°	-14°	-6°
-30°	-22°	-8°
-40°	-37°	-3°
0°	3°	-3°
10°	12°	-2°
20°	21°	-1°
30	19°	11°
40°	36°	4°
0°	2°	-2°
-10°	-8°	-2°
-20°	-16°	-4°
-30°	-24°	-6°
-40°	-31°	-9°
0°	1°	-1°
10°	9°	1°
20°	16°	4°
30°	26°	4°
40°	33°	7°
0°	-2°	2°
-10°	-11°	1°
-20°	-19°	-1°
-30°	-26°	-4°
-40°	-35°	-5°

Original Vertical Angle Repeatability		
Desired Angle	Actual Angle	Difference
0°	-1°	1°
10°	8°	2
20°	19°	1
30°	29°	1
0°	0	0
-10°	-12°	2
-20°	-19°	-1
-30°	-30°	0
0°	0°	-0
10°	10°	0
20°	19°	1
30°	28.0°	2
0°	0°	0
-10°	-8°	-2
-20°	-19°	-1
-30°	-28°	-2
0°	1°	-1
10°	11°	-1
20°	17°	3
30°	28°	2
0°	0°	0
-10°	-10°	0
-20°	-20°	0
-30°	-28°	-2

<b>Iteration 3: Horizontal Angle Qualification</b>			
		<b>Total Angle Rotation</b>	<b>Difference</b>
<b>Starting Position:</b>	<b>202°</b>	<b>0°</b>	<b>0</b>
Position 1 (10°):	<b>192°</b>	<b>10°</b>	<b>0</b>
Position 2 (20°):	<b>182°</b>	<b>20°</b>	<b>0</b>
Position 3 (30°):	<b>172°</b>	<b>30°</b>	<b>0</b>
<b>Return Position:</b>	<b>201°</b>	<b>-1°</b>	<b>-1°</b>
<b>Starting Position:</b>	<b>200°</b>	<b>0°</b>	<b>0</b>
Position 1 (10°):	<b>189°</b>	<b>11°</b>	<b>1°</b>
Position 2 (20°):	<b>179°</b>	<b>20°</b>	<b>0</b>
Position 3 (30°):	<b>169°</b>	<b>30°</b>	<b>0</b>
<b>Return Position:</b>	<b>200°</b>	<b>1°</b>	<b>1°</b>
<b>Starting Position:</b>	<b>198°</b>	<b>0°</b>	<b>0</b>
Position 1 (10°):	<b>187°</b>	<b>11°</b>	<b>1°</b>
Position 2 (20°):	<b>178°</b>	<b>19°</b>	<b>-1°</b>
Position 3 (30°):	<b>168°</b>	<b>30°</b>	<b>0</b>
<b>Return Position:</b>	<b>197°</b>	<b>-1°</b>	<b>-1°</b>
<b>Starting Position:</b>	<b>196°</b>	<b>0°</b>	<b>0</b>
Position 1 (10°):	<b>185°</b>	<b>11°</b>	<b>1°</b>
Position 2 (20°):	<b>175°</b>	<b>20°</b>	<b>0</b>
Position 3 (30°):	<b>165°</b>	<b>30°</b>	<b>0</b>
<b>Return Position:</b>	<b>195°</b>	<b>-1°</b>	<b>-1°</b>
<b>Starting Position:</b>	<b>202°</b>	<b>0°</b>	<b>0</b>
Position 1 (10°):	<b>192°</b>	<b>10°</b>	<b>0</b>
Position 2 (20°):	<b>182°</b>	<b>20°</b>	<b>0</b>
Position 3 (30°):	<b>172°</b>	<b>30°</b>	<b>0</b>
<b>Return Position:</b>	<b>201°</b>	<b>-1°</b>	<b>-1°</b>
<b>Starting Position:</b>	<b>200°</b>	<b>0°</b>	<b>0</b>
Position 1 (10°):	<b>189°</b>	<b>11°</b>	<b>1°</b>
Position 2 (20°):	<b>179°</b>	<b>20°</b>	<b>0</b>
Position 3 (30°):	<b>169°</b>	<b>30°</b>	<b>0</b>
<b>Return Position:</b>	<b>200°</b>	<b>1°</b>	<b>1°</b>
<b>Starting Position:</b>	<b>198°</b>	<b>0°</b>	<b>0</b>
Position 1 (10°):	<b>187°</b>	<b>11°</b>	<b>1°</b>
Position 2 (20°):	<b>178°</b>	<b>19°</b>	<b>-1°</b>

Position 3 (30°):	168°	30°	0
<b>Return Position:</b>	<b>197°</b>	<b>-1°</b>	<b>-1°</b>
<b>Starting Position:</b>	<b>196°</b>	<b>0°</b>	<b>0</b>
Position 1 (10°):	185°	11°	1°
Position 2 (20°):	175°	20°	0
Position 3 (30°):	165°	30	0
<b>Return Position:</b>	<b>195°</b>	<b>-1°</b>	<b>-1°</b>

## Appendix F

This is the code that is used to run the two Motors that dictate the Horizontal and Vertical Motion.

```
#include <MotorShield.h>

MS_DCMotor motorA(MOTOR_A);
MS_DCMotor motorB(MOTOR_B);

#include <Wire.h>
#include "MotorDriver.h"

//The sample code for driving one way motor encoder
const byte encoderApinA = 2;//A pin -> the interrupt pin 2
const byte encoderApinB = 4;//B pin -> the digital pin 4
byte encoderAPinALast;

const byte encoderBpinA = 3;//A pin -> the interrupt pin 2
const byte encoderBpinB = 5;//B pin -> the digital pin 4
byte encoderBPinALast;

volatile long duration;//the number of the pulses
boolean Direction;//the rotation direction

volatile long durationB;//the number of the pulses
boolean DirectionB;//the rotation direction

int button = 7; //pin for button
int horz = 0;
int horzpos10 = 300;
int horzpos20 = 600;
int horzpos30 = 900;
int horzneg10 = 0;
int horzneg20 = 0;
int horzneg30 = 0;

int vert = 0;
int vertpos10 = 300;
int vertpos20 = 0;
int vertpos30 = 0;
int vertneg10 = 0;
int vertneg20 = 0;
int vertneg30 = 0;

int motorSpeedA = 255;
int motorSpeedB = 100;
int sleepTime = 5;
```

```

void setup()
{

  motorA.run(BRAKE);
  motorA.setSpeed(motorSpeedA);
  motorB.run(BRAKE);
  motorB.setSpeed(motorSpeedB);

  pinMode(button, INPUT_PULLUP);

  Serial.begin(57600);//Initialize the serial port
  EncoderInit();//Initialize the module
}

void loop()
{
  watchButton();
  writeAngleB(horzpos10);
  watchButton();
  writeAngleB(horzpos10);
  watchButton();
  writeAngleB(horzpos10);
  watchButton();
  goHomeB(horzpos30);
  /*
  watchButton();
  writeAngleA(vertpos10);
  watchButton();
  goHomeA(vertpos10);
  */
}

void EncoderInit()
{
  Direction = true;//default -> Forward
  pinMode(encoderApinB,INPUT);
  attachInterrupt(0, wheelSpeedA, CHANGE);//int.0

  DirectionB = true;//default -> Forward
  pinMode(encoderBpinB,INPUT);
  attachInterrupt(0, wheelSpeedB, CHANGE);//int.0
}

void wheelSpeedA()
{
  int Lstate = digitalRead(encoderApinA);
  if((encoderAPinALast == LOW) && Lstate==HIGH)
  {

```

```

int val = digitalRead(encoderAPinB);
if(val == LOW && Direction)
{
    Direction = false; //Reverse
}
else if(val == HIGH && !Direction)
{
    Direction = true; //Forward
}
}
encoderAPinALast = Lstate;

if(!Direction) duration++;
else duration--;
}

void wheelSpeedB()
{
int Lstate = digitalRead(encoderBpinA);
if((encoderBPinALast == LOW) && Lstate==HIGH)
{
int val = digitalRead(encoderBpinB);
if(val == LOW && DirectionB)
{
    DirectionB = false; //Reverse
}
else if(val == HIGH && !DirectionB)
{
    DirectionB = true; //Forward
}
}
encoderBPinALast = Lstate;

if(!DirectionB) durationB++;
else durationB--;
}

void watchButton(){
while(1){
if(digitalRead(button) == LOW){
    break;
}
delay(sleepTime);
}
delay(500);
}
}

```



```

void writeAngleA(int targetDegree){
    duration = 0;
    motorA.run(BACKWARD|RELEASE);
    delay(targetDegree);
    motorA.run(BRAKE);
}

void goHomeA(int targetDegree){
    motorA.run(FORWARD|RELEASE);
    delay(targetDegree);
    motorA.run(BRAKE);
    //motordriver.stop();
    //motordriver.setDirection(MOTOR_CLOCKWISE, MOTORA);
    //motordriver.setDirection(MOTOR_CLOCKWISE, MOTORB);
}

void writeAngleB(int targetDegree){
    durationB = 0;
    motorB.run(BACKWARD|RELEASE);
    delay(targetDegree);
    motorB.run(BRAKE);
}

void goHomeB(int targetDegree){
    motorB.run(FORWARD|RELEASE);
    delay(targetDegree);
    motorB.run(BRAKE);

    //motordriver.stop();
    //motordriver.setDirection(MOTOR_CLOCKWISE, MOTORA);
    //motordriver.setDirection(MOTOR_CLOCKWISE, MOTORB);
}

```

## Appendix G

### Electronics Hookups for Motors A and B

Motor A (Vertical Motor)	
Red	Motor Shield Positive
Black	Motor Shield Negative
Green	Breadboard Ground
Blue	Breadboard Positive
Yellow	Motor Shield Pin 2
White	Motor Shield Pin 4
Motor B (Horizontal Motor)	
Orange	Motor Shield Pin 5
Blue	Motor Shield Pin 3
Green	Motor Shield Negative
Yellow	Motor Shield Positive
Red	Breadboard Positive
Black	Breadboard Ground
Breadboard Connections	
Breadboard Positive	Motor Shield 5V
Breadboard Ground	Motor Shield Ground
For Button: Ground	Connects with Pin 7
Motor Shield to Power Adapter	
Motor Shield Vin	Power Adapter Vin
Motor Shield Ground	Power Adapter Ground