

the MODEL 301

modular smoke detection
from

 STATITROL®

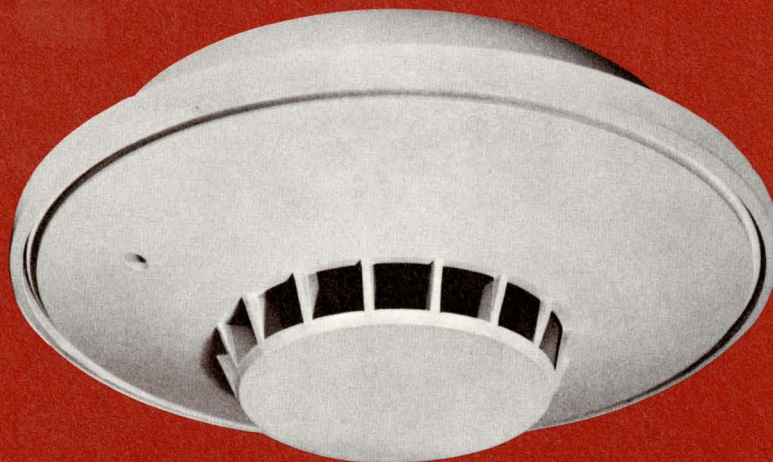

features

The modular design provides maximum flexibility.

The separate Mounting Base Assembly allows for both two-wire and four-wire installation and provides a mounting receptacle for any of the three MODEL 301 detectors known as the 301G, 301H, and 301J.

The choice of Normally-Open or Normally-Closed Alarm Contacts makes the MODEL 301 easily adaptable to any fire protection system.

The built-in LED Alarm Light provides a visual indication of the sensitivity condition of the MODEL 301H and MODEL 301J detectors.

The low profile design of the MODEL 301 provides a pleasing appearance.

The patented Duo-Centric™ Ionization Chamber provides stable operation and compensates for changes in temperature, humidity, and barometric pressure.

The customer-accessible Sensitivity Control allows for accurate sensitivity setting for special applications.

Built-in circuitry allows for a Remote Alarm Indicating Lamp (RAIL) connection.

The Mounting Base Assembly is supervised such that removal of a detector produces a trouble indication on a Central Fire Control Panel.

Self-wiping contacts, an exclusive Statitrol design, allow twist-lock insertion and removal of the detector for easy maintenance and service.

The Ceiling Removal and Test Tool allows sensitivity measurement, in addition to the LED indicator, without removing the detector from the ceiling.

The pre-wired Mounting Base Assembly permits pre-installation wiring check-out from the Fire Control Panel.

Very low operating current allows more detector installations per zone and lower standby power costs.

When used in a four-wire installation, the MODEL 301 replaces the Statitrol MODEL 040 detector.

The MODEL 301 is Underwriters' Laboratories listed.

the MODEL 301

The STATITROL MODEL 301 is the latest generation of Statitrol Ionization Chamber Smoke Detectors designed for commercial applications. More than two years of development and testing have resulted in a product of superior reliability and flexibility without sacrificing economy.

The patented Duo-Centric™ ionization chamber which compensates for changing environmental variables provides stable operation with a single radiation source.

The modular hardware design provides the fire protection system designer with the most complete array of options available today. The MODEL 301 hardware allows for either a two-wire or four-wire installation operating from 24VDC, 120VAC, or 220/240 VAC, and for each detector installation the system designer may choose from 396 different relay and circuit configurations, LED functions, and mounting alternatives.

The MODEL 301 has been tested to provide maximum reliability while demanding minimum service and is designed to meet the requirements of the Underwriters' Laboratories, Factory Mutual, Underwriters' Laboratory of Canada, Fire Office Committee of the U.K., Verband der Sachversicherer of Germany, and the U.S. Nuclear Regulatory Commission for commercial installations in the United States, Canada, and Europe.

001
for basic two-wire zone installation, has Remote Alarm Indicator Lamp connection, but no additional accessory connections

002
has Remote Alarm Indicator Lamp connection and a double-pole, double-throw alarm and accessory control relay. Additionally, the 002 mounting base assembly is designed for use in both two-wire and four-wire installations

003
designed for use in a four-wire installation with a normally-closed alarm circuit. Has Remote Alarm Indicator Lamp connections, one single-pole, double-throw accessory relay contact and a normally-closed trouble relay contact to supervise the power circuit

004
designed for use in a four-wire installation with a normally-open alarm circuit. Contains Remote Alarm Indicator Lamp connections, one SPDT accessory relay contact, and a normally closed trouble relay contact to supervise the power circuit.

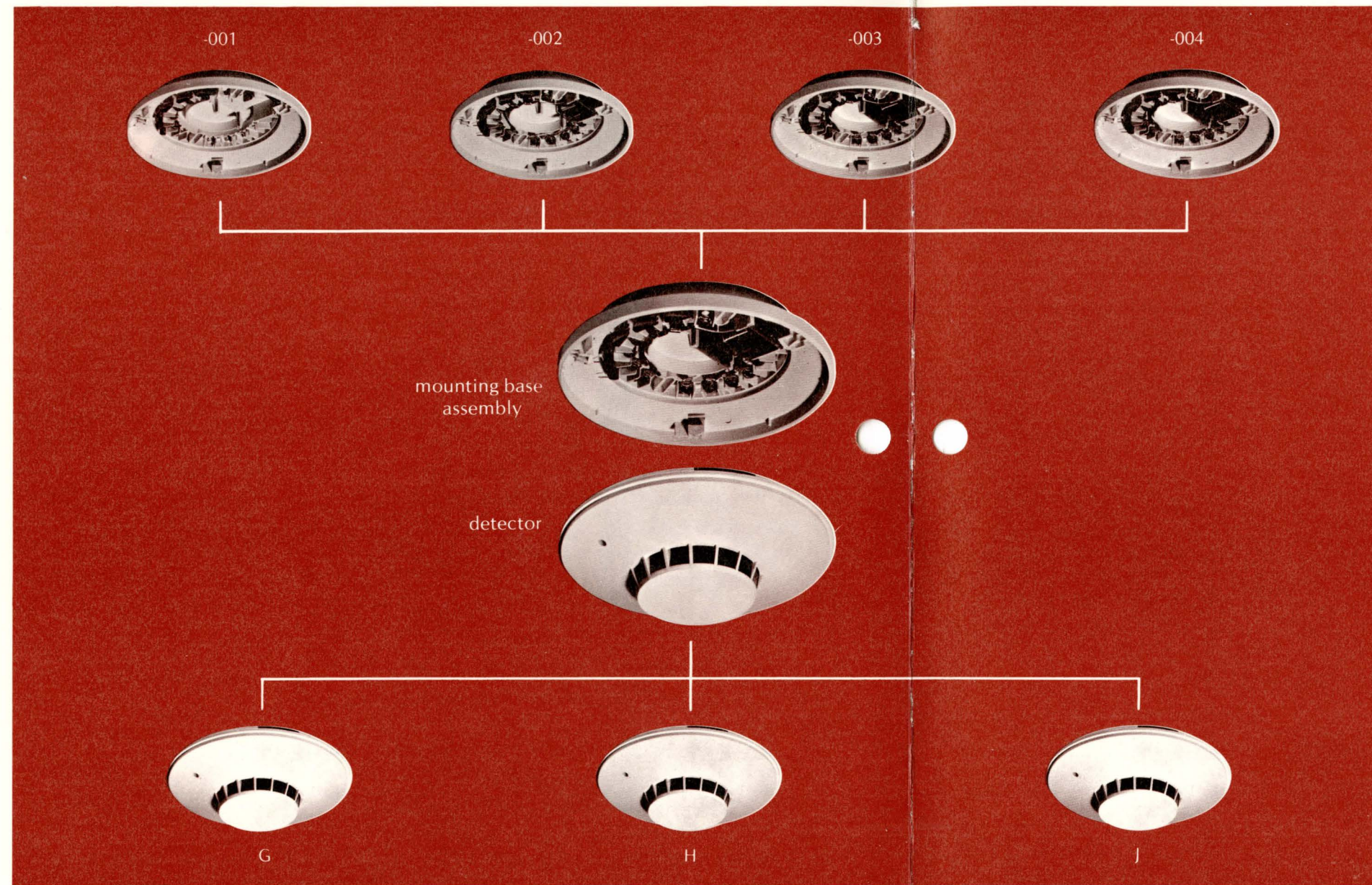

301G
designed as a basic detector containing a built-in alarm LED and Sensitivity Control. The MODEL 301G is usable in both a two-wire and four-wire installation, but because of its low current drain in standby it is specially suited for two-wire installations

301H
contains the Sensitivity Control and an alarm and sensitivity-indicating LED that allows the user to visually monitor the detector sensitivity. The sensitivity-indicating LED flashes between 60 and 90 pulses per minute in supervisory or standby condition. If the LED is flashing faster than 90 pulses per minute, the detector has become less sensitive. If it is flashing slower than 60 pulses per minute the detector has become more sensitive. The MODEL 301H detector is usable only in a four-wire installation.

301J
contains the Sensitivity Control and an alarm LED that also gives a visual indication of the detector sensitivity condition. In normal standby condition the LED does not flash. Only when the detector sensitivity is outside of the designed sensitivity range does the LED begin to flash. If the detector has become less sensitive, the LED will flash faster than 90 pulses per minute, if the detector has become more sensitive the LED will flash slower than 60 pulses per minute. Because of its low current drain in standby the MODEL 301 J is usable in either a two-wire (with special panel provisions) or four-wire installation.

modular hardware design

The modular hardware design and a complete line of accessories make the MODEL 301 fully adaptable to the needs of a specific fire detection system and most cost effective by allowing the designer to select only the special features desired for a specific detector location.

The modular hardware allows the designer the choice of four different mounting base assemblies and three different detectors. The mounting base assemblies are identified by the eleven digit part number located on the inside of the mounting base assembly. However, in the Statitrol MODEL 301 technical literature the mounting base assemblies are identified by their last three digits as follows: -001, -002, -003, -004.

The three different MODEL 301 detectors are designated as MODEL 301G, MODEL 301H, and MODEL 301J. All three detector types will fit any of the four mounting base assemblies (except the MODEL 301H which is not compatible with the -001 base). All three detectors have a Sensitivity Control and an Alarm LED which remains ON in the alarm condition. Exclusive self-wiping contacts allow snap-lock removal and insertion of the detector for easier maintenance and service.

wiring

The MODEL 301 detector mounting base assembly is designed to ease the job of both the designer and installer of the Fire Protection System. All field connections are made to numbered terminals in the mounting base assembly. The mounting base assembly is pre-wired to allow a pre-installation wiring checkout at the Fire Control Panel and input DC wiring is not polarity dependent.

The accompanying schematics illustrate combined mounting base installation wiring and system connections. Also illustrated are mounting dimensions.

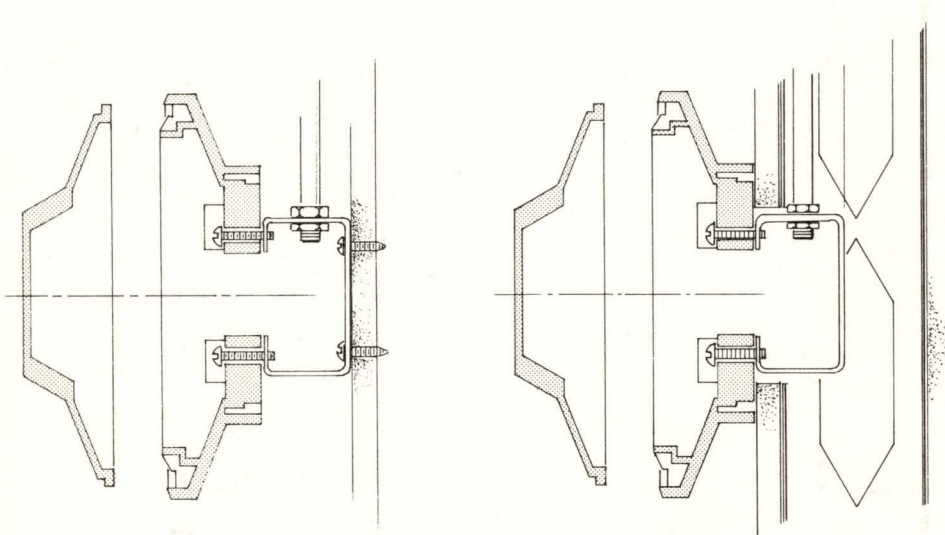
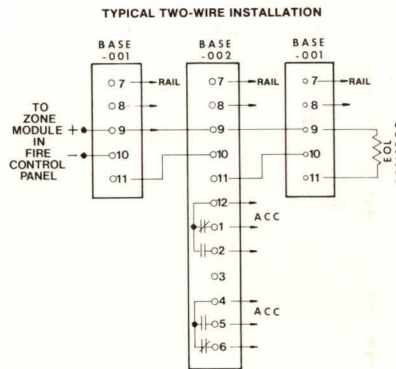
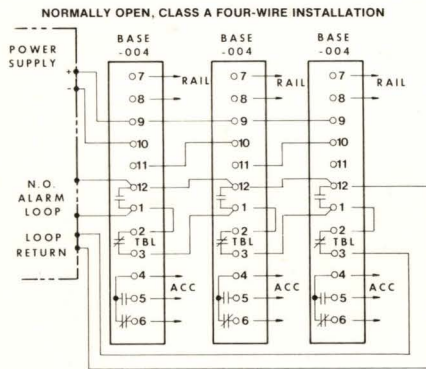
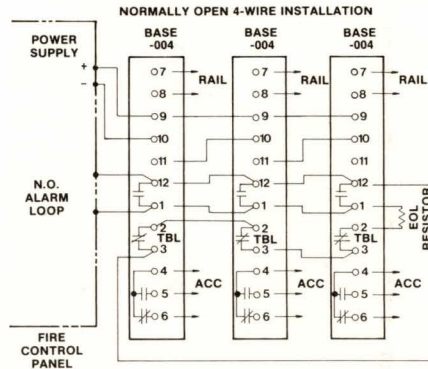
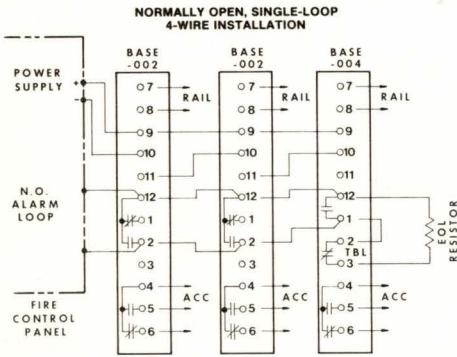

Dimensions: 7.5" diameter x 2.65" high

accessories

A full compliment of MODEL 301 accessories allows the designer to adapt both the installation and the system configuration and provide for easy maintenance and service.

A. The Ceiling Extension Hanger provides a variable length hanging mount for high ceiling installations.

B. The Surface Mounting Adaptor Box is a non-metallic electrical box for installation where surface wiring is used or for adapting to international electrical boxes.

C. The Ceiling Removal and Test Tool is used for both testing the detector sensitivity while the detector is installed and for removing and reinserting the detector into the mounting base assembly.

D. The Power Pack converts 120 VAC or 220/240 VAC to 24 VDC where DC system power is not available.

E. The normally-closed alarm contact resistor is for installation in the mounting base assembly when the MODEL 301 is used in a normally-closed alarm circuit.

technical data

Power Requirements:

24VDC (+ 10%, -15%); 100 mV max. ripple

Standby Current:

Detector: 301G & 301J: 100 micro-amps Max. @ 24 VDC
301H: 7 mA Max. @ 24 VDC

Base: -001, -002: No standby current
-003, -004: 10 mA Max. @ 24 VDC

Alarm Current: (not including RAIL current)

Detector: 301G & 301J: 50 mA Max. @ 24 VDC
301H: 55 mA Max. @ 24VDC

Base: -001: No alarm current
-002: 30 mA Max. @ 24 VDC
-003, -004: 40 mA Max. @ 24 VDC

Formula For Computing Total Zone Current Loads:

$$I_{TOTAL} = I_{BASE} + I_{DETECTORS} + I_{RAILS}$$

Remote Alarm Indicator Lamp (RAIL):

40 mA Max. @ 24 VDC supplied

Accessory Relay Contact Rating:

3 A Max. @ 24 VDC or 120 VAC, Resistive
1.5 A Max @ 24 VDC or 120 VAC, Inductive
(5 times inrush at 0.5 pf)

Trouble Contact Rating:

0.125 A at 120 VAC, resistive

LED Pulse Rate:

301G: LED does not pulse
301H: 60-90 ppm
301J: 90-120 ppm: insensitive
No flash indicates operation in the designed operating range
30-60 ppm: too sensitive

Wiring:

1. Remote Alarm Indicator lamp (RAIL) and power input wires are power-limited, (refer to NEC 760-30).
2. All other accessory relay wires and alarm relay wires can be power-limited (refer to NEC 760-30) or non-power-limited (refer to NEC 760-16 and 760-17)

Power Pack:

Input: 120 or 220/240, 50/60 hz.
VAC (+ 10%, -15%)
80 mA max.
Output: 24 VDC
150 mA Max.

Environmental Specifications :

Velocity: 15-150 fpm continuous, up to 2000 fpm gusts
Temp: 32° F. - 120° F.
Humidity: 10% - 85% R.H.
Altitude: 0 ft. - 10,000 ft.

Installations that may require adjustment of sensitivity:

- a. locations too close to fans, open window, or high velocity air ducts
- b. locations with continuously elevated temperatures
- c. locations of high fume or gas accumulation
- d. high altitudes

Mechanical Specifications :

Dimensions: 7.5" diameter x 2.65" high
Color: Off-white
Material: Heat resistant Noryl® plastic

Approvals:

Underwriter's Laboratories, Inc. Listed



accessories

A full compliment of MODEL 301 accessories allows the designer to adapt both the installation and the system configuration and provide for easy maintenance and service.

A. The Ceiling Extension Hanger provides a variable length hanging mount for high ceiling installations.

B. The Surface Mounting Adaptor Box is a non-metallic electrical box for installation where surface wiring is used or for adapting to international electrical boxes.

C. The Ceiling Removal and Test Tool is used for both testing the detector sensitivity while the detector is installed and for removing and reinserting the detector into the mounting base assembly.

D. The Power Pack converts 120 VAC or 220/240 VAC to 24 VDC where DC system power is not available.

E. The normally-closed alarm contact resistor is for installation in the mounting base assembly when the MODEL 301 is used in a normally-closed alarm circuit.

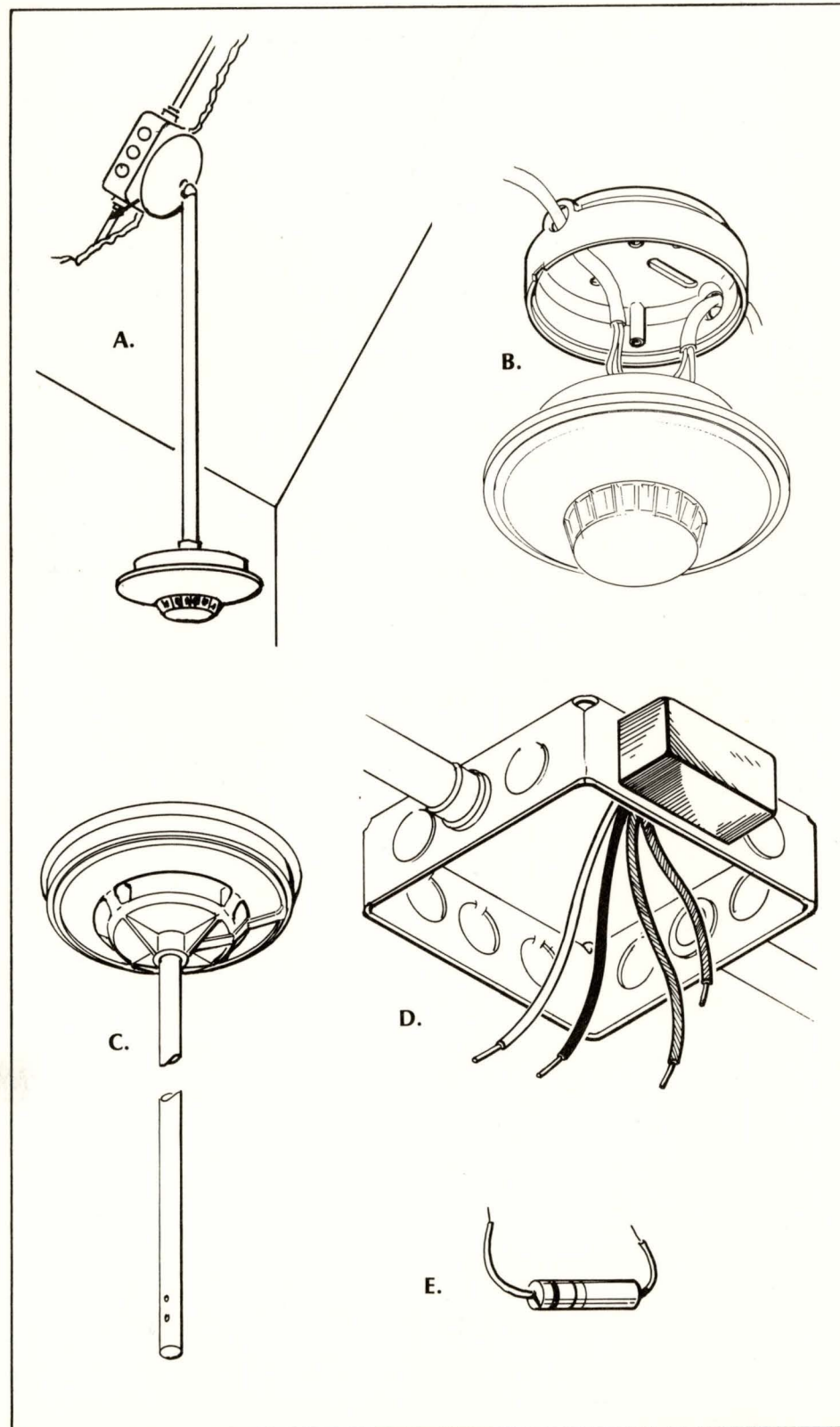

additional information

The Statitrol technical literature on the MODEL 301 includes a 24-page technical bulletin that explains the following topics:

Principles of Operation
Location of Detectors
Installation and Wiring
Operation
Maintenance
Technical Data

Copies of the technical bulletin or any additional information may be obtained from:

Application Engineering
Statitrol Division
Emerson Electric Company
140 South Union Boulevard
Lakewood, Colorado 80228

specification

1. The smoke detection device shall be a Statitrol MODEL 301. It shall operate on the ionization principle and shall be activated by the presence of combustion products. The ion chamber shall operate on the dual chamber principle (Duo-Centric™ Chamber) and be self-compensating for the effects of humidity, temperature and altitude.
2. The detection device shall be listed by Underwriters' Laboratories, Inc.
3. The detection device shall be of the plug-in type with a twist lock feature. The detector head shall contain the ionization chamber, amplifier, switching circuit, alarm indicator lamp and sensitivity monitoring circuits. The detector mounting base shall contain the necessary alarm, auxiliary and trouble relays.
4. The detection device shall lock into the alarm condition and must be manually reset from the F/A panel or locally at the detection device. Reset shall be performed by interrupting power to the detector. The detector shall have an alarm indicating lamp which is on in the alarm condition. The detector shall also have provisions for connections of a remote alarm indicator lamp.
5. The detector mounting base shall contain all provisions for electrical connections. All electrical connections shall be of the screw terminal type. The screw terminals shall be available without removal of the mounting base from the ceiling.
6. It shall be possible to electrically check the detector's sensitivity without removing the detector from its mounting base. This electrical test shall be performed with a standard voltmeter having an input impedance of at least 5 megohms.
7. The detector shall provide a visual indication of the condition of detector sensitivity where required. In four-wire applications, where required, an integral flashing light with flash rate proportional to sensitivity shall be provided. In two-wire applications, where required, an integral flashing light which flashes when the detector sensitivity is out of specified limits shall be provided.
8. In four-wire applications, a normally open or normally closed alarm relay contact, SPDT auxiliary contacts, and normally closed trouble relay contacts shall be provided, where required. In two-wire applications, SPDT alarm relay shall be provided, where required.
9. A technical bulletin for the detector shall be made available. The technical bulletin shall contain information describing the following: Principles of Operation; Guide to Location of Detectors; Installation and Wiring; Operation; Maintenance and Testing; and, Technical Data.
10. The detector shall have a customer-accessible sensitivity control. The sensitivity control shall allow for adjustment of sensitivity within approval agency limits.
11. A ceiling removal and test tool shall be provided when required. The tool shall allow for access to detectors mounted on ceilings up to 12 ft. from the floor.
12. The detector mounting base shall be supplied with a pre-installed jumper. This pin jumper shall be wired so that a system continuity test can be made prior to detector head installation.
13. An extension hanger which allows installation at a variable distance below the ceiling shall be provided, where required.

ordering

This table provides the complete part numbers for all of the MODEL 301 components and accessories. When ordering, specify the component with the complete part number. The component groups usable in the four-wire and two-wire installations have been shaded for easier reference.

Direct inquiries or orders to:

Statitrol Division
Emerson Electric Company
140 South Union Boulevard
Lakewood, Colorado 80228

two-wire installations

Mounting Base Assembly Detector	-001	-002 DPDT Alarm or Accessory	-003 N.C. Alarm SPDT Accessory N.C. Trouble	-004 N.O. Alarm SPDT Accessory N.C. Trouble
Model 301 G	ORDER Detector: 301G7101-1 Mounting Base: 0301-0003-001	ORDER Detector: 301G7101-1 Mounting Base: 0301-0003-002	ORDER Detector: 301G7101-1 Mounting Base: 0301-0003-003	ORDER Detector: 301G7101-1 Mounting Base: 0301-0003-004
Model 301 H	(The Model 301 H is not compatible with the -001 base.)	ORDER Detector: 301H7101-1 Mounting Base: 0301-0003-002	ORDER Detector: 301H7101-1 Mounting Base: 0301-0003-003	ORDER Detector: 301H7101-1 Mounting Base: 0301-0003-004
Model 301 J	ORDER Detector: 301J7101-1 Mounting Base: 0301-0003-001	ORDER Detector: 301J7101-1 Mounting Base: 0301-0003-002	ORDER Detector: 301J-7101-1 Mounting Base: 0301-0003-003	ORDER Detector: 301J7101-1 Mounting Base: 0301-0003-004

four-wire installations

Mounting Base Assembly Detector	-001	-002 DPDT Alarm or Accessory	-003 N.C. Alarm SPDT Accessory N.C. Trouble	-004 N.O. Alarm SPDT Accessory N.C. Trouble
Model 301 G	ORDER Detector: 301G7101-1 Mounting Base: 0301-0003-001	ORDER Detector: 301G7101-1 Mounting Base: 0301-0003-002	ORDER Detector: 301G7101-1 Mounting Base: 0301-0003-003	ORDER Detector: 301G7101-1 Mounting Base: 0301-0003-004
Model 301 H	(The Model 301 H is not compatible with the -001 base.)	ORDER Detector: 301H7101-1 Mounting Base: 0301-0003-002	ORDER Detector: 301J-7101-1 Mounting Base: 0301-0003-003	ORDER Detector: 301H7101-1 Mounting Base: 0301-0003-004
Model 301 J	ORDER Detector: 301J7101-1 Mounting Base: 0301-0003-001	ORDER Detector: 301J7101-1 Mounting Base: 0301-0003-002	ORDER Detector: 301J-7101-1 Mounting Base: 0301-0003-003	ORDER Detector: 301J7101-1 Mounting Base: 0301-0003-004



STATITROL DIVISION
EMERSON ELECTRIC CO.
140 SOUTH UNION BOULEVARD
LAKEWOOD, COLORADO 80228
(303) 986-1581

SURFACE MOUNTING ADAPTOR BOX
P/N 102-0221-001
120 VAC POWER PACK
P/N 0301-0013-001
220/240 VAC POWER PACK
P/N 0301-0013-002

EXTENSION HANGER ADAPTOR
P/N 0301-0056-001
CEILING REMOVAL AND TEST TOOL
P/N 0301-0055-001
N.C. ALARM CONTACT RESISTOR
P/N 0301-0053-001 (47 KΩ), OR
P/N 0301-0053-002 (200 KΩ).