

# **The Historical Evolution of Arms and Armor: The European Arming Sword and Japanese Uchigatana**

An Interactive Qualifying Project  
submitted to the Faculty of  
WORCESTER POLYTECHNIC INSTITUTE  
in partial fulfillment of the requirements for the  
degree of Bachelor of Science

By

Brendan Corcoran

Christopher Francis

Colby Jensen

Kevin Piskorowski

David Van Sickle

Date:

May 13, 2021

Report Submitted to:

Professor Diana A. Lados

This report represents the work of one or more WPI undergraduate students submitted to the faculty as evidence of completion of a degree requirement. WPI routinely publishes these reports on the web without editorial or peer review.

# **ABSTRACT**

The late medieval period of Europe (1250-1500 AD) and the Kamakura Period of Japan (1185-1333 AD) were both eras defined by perpetual conflict and warfare. As a result, a rich history of weapons and armor was developed. The sword was one such weapon that saw widespread use in combat. This project seeks to investigate two specific swords, the European arming sword and the Japanese uchigatana. The factors that led to these swords' demand and forging processes used to create them will be revealed with a thorough exploration of the historical context. Additionally, replicas of both an arming sword and uchigatana will be fabricated in a historically representative manner. An analysis of the design, forging process, and materials science aspects will be considered to compare these two swords, originating from two vastly different regions of the world in a similar time of unrest.

# ACKNOWLEDGMENTS

The team would like to first thank Professor Diana Lados for involving us with this multifaceted and in-depth learning experience. We would also like to thank Joshua Swalec for generously allowing us access to his workshop and tools for our replica construction. He also taught us much about the blacksmithing trade and the team is extremely grateful for all the helpful knowledge Joshua provided throughout our time together. We are also grateful for the help provided by Jeff Hollan and Saint-Gobain as well as Kim Hollan of WPI for donating and delivering the special abrasive belts used in the final stages of preparation of our replicas to achieve the desired dimensions and surface finish. Ian Anderson and Matt Ryder also contributed to this project, and we would like to thank them for all the guidance they gave us at the WPI Washburn Shops.

# TABLE OF CONTENTS

Abstract.....	2
Acknowledgments .....	3
Table of Contents .....	4
List of Figures.....	6
List of Tables.....	8
1. Introduction.....	9
2. European Background.....	9
2.1. History .....	9
2.1.1. Contextual Time Periods .....	9
2.1.1.A. Late Medieval Age .....	9
2.1.1.B. High Medieval Age.....	10
2.1.1.C. The Renaissance.....	10
2.1.2. Important Nations.....	11
2.1.2.A. England.....	11
2.1.2.B. France .....	13
2.1.2.C. Hungary .....	14
2.1.3. Major Events .....	15
2.1.3.A. The Avignon Papacy (1309-1377) .....	15
2.1.3.B. The Great Famine (1315-1322).....	16
2.1.3.C. The Black Death (1346-1353) .....	17
2.1.3.D. The Western Schism (1378-1417).....	18
2.1.4. Wars/Conflicts .....	18
2.2. Arms and Armor of the Late Medieval Period.....	19
2.2.1. Classification of Soldiers .....	20
2.2.1.A. Monarchs .....	20
2.2.1.B. Nobles.....	20
2.2.1.C. Knights .....	20
2.2.1.D. Mercenaries .....	21
2.2.1.E. Archers.....	21
2.2.2. Armor .....	21
2.2.2.A. Plate Armor .....	21
2.2.2.B. Chain Mail.....	22
2.2.2.C. Shields .....	22
2.2.2.D. Horse Armor.....	23
2.2.3. Melee Weapons.....	23
2.2.3.A. Swords .....	23
2.2.3.B. Spears, Pikes, Halberds.....	23
2.2.3.C. Daggers .....	24
2.2.4. Ranged Weapons.....	24
2.2.4.A. Longbow .....	24
2.2.4.B. Crossbow.....	25
2.2.5. The Arming Sword (Knightly Sword) .....	25
2.2.5.A. Design .....	26
2.2.5.B. Location .....	26
2.2.5.C. Utilization.....	27

2.2.5.D. Origin of Weapon .....	27
2.3. Materials and Forging Technology .....	28
2.3.1. Materials of Late Medieval Europe .....	28
2.3.2. Historical European Forging Techniques .....	28
2.3.3. Forging of an Arming Sword .....	29
3. Japanese Background.....	30
3.1. History .....	30
3.1.1. Time period .....	30
3.1.1.A. Heian Period .....	30
3.1.1.B. Kamakura Period .....	31
3.1.1.C. Muromachi Period .....	32
3.1.2. Important Clans.....	33
3.1.2.A. Taira and Minamoto Clans.....	33
3.1.2.B. Hojo Clan .....	33
3.1.3. Wars/Conflicts .....	33
3.1.3.A. Hogen, Heiji, and Genpei War.....	33
3.1.3.B. Mongolian Invasions.....	34
3.1.3.C. Sengoku Jidai.....	34
3.2. Arms and Armor of the Kamakura Period.....	35
3.2.1. Samurai.....	35
3.2.2. Ashigaru .....	36
3.2.3. Samurai Armor .....	36
3.2.4. Weapons .....	37
3.2.4.A. Uchigatana .....	37
3.2.4.B. Yumi.....	37
3.2.4.C. Tachi.....	38
3.2.4.D. Yari .....	38
3.2.4.E. Naginata .....	39
3.2.5. Uchigatana History .....	39
3.2.5.A. Design .....	39
3.2.5.B. Location .....	40
3.2.5.C. Applications.....	40
3.2.5.D. Origins.....	41
3.3. Forging Process .....	41
3.3.1. Materials of Kamakura Period.....	41
3.3.2. Historical Japanese Forging Techniques .....	41
3.3.3. Uchigatana .....	42
4. Materials Science Considerations .....	42
4.1. Materials Selection.....	42
4.1.1. Compositions, Mechanical Properties, and Common Uses .....	42
4.1.1.A. 1075 Carbon Steel .....	42
4.1.1.B. 1045 Carbon Steel.....	43
4.1.2. Mechanical and Physical Properties of the Selected Steels .....	43
4.1.3. Iron-Carbon (Fe-C) Phase Diagram.....	43
4.1.4. Predicted Microstructures of the Selected Steels (1075 and 1045) .....	46
4.1.5. Steel Sample Spectroscopy .....	46
4.1.6. Updated Microstructures of Both Steels (1075 and 1045).....	47
4.1.7. Replica Carbon Steel Alloys .....	47

4.2. Microstructure Analysis Process .....	48
4.3. Heat Treatment and Effects of Cooling Rates.....	51
4.3.1. Types of Heat Treatment .....	51
4.3.2. Phase Transformations .....	52
4.3.2.A. Equilibrium Cooling .....	52
4.3.2.B. Non-Equilibrium Cooling .....	53
4.3.3. Worked/Heat Treated Microstructure Analysis .....	57
5. Forging Techniques.....	60
5.1. Traditional Methods .....	60
5.1.1. Traditional European Forging .....	60
5.1.2. Traditional Japanese Forging .....	62
5.2. Modern Forging Methods.....	64
6. Replica Construction .....	68
6.1. European Arming Sword.....	68
6.1.1. Preparation .....	68
6.1.2. Forging .....	69
6.1.3. Grinding.....	73
6.1.4. Heat Treatment .....	77
6.2. Uchigatana.....	77
6.2.1. Preparation .....	77
6.2.2. Forging .....	78
6.2.3. Grinding.....	80
6.2.4. Heat Treatment .....	81
7. Conclusions.....	81
Appendix: Website Additions.....	82
A.1. European Background.....	82
A.2. Arming Sword Replica Construction.....	88
A.3. Japanese Background.....	91
A.4. Uchigatana Replica Construction.....	94
References .....	97

## LIST OF FIGURES

<b>Figure 2.1.</b> Dante’s mosaic in the Florence Baptistry 13th century (Collins, 2015). .....	10
<b>Figure 2.2.</b> School of Athens by Raphael 1509 (Sanzio, 2013). .....	11
<b>Figure 2.3.</b> King Henry VII of England (Sittow, 2019). .....	12
<b>Figure 2.4.</b> Charles VIII of France (Longueville, 2020). .....	14
<b>Figure 2.5.</b> The Siege of Constantinople (Le Tavernier, 1455). .....	15
<b>Figure 2.6.</b> Palace of the Pope in Avignon, France (Unknown, 2019). .....	16
<b>Figure 2.7.</b> Mural of “The Triumph of Death” of the plague (Forman, 2020). .....	17
<b>Figure 2.8.</b> Battle of Crécy in 1346 (Ancient History Encyclopedia, 2020).....	19
<b>Figure 2.9.</b> Tapestry depicting a 13th century German knight (Manesse, 1305).....	21
<b>Figure 2.10.</b> Plate armor circa 1450 (Missaglia, 2012). .....	22
<b>Figure 2.11.</b> Chain mail specimen circa 1361 (Sauber, 2007). .....	22
<b>Figure 2.12.</b> Replica of a medieval era sword (Niedziella, 2011).....	23
<b>Figure 2.13.</b> Medieval polearms (Universe, 2015).....	24
<b>Figure 2.14.</b> An English longbow representative of the time period (Cram, 2007).....	25

<b>Figure 2.15.</b> Medieval crossbow circa 1500 (Mohr, 2016).	25
<b>Figure 2.16.</b> Bristol medieval arming sword (Suttles, 2017).	26
<b>Figure 2.17.</b> Arming sword design diagram (Oakeshott, 2013).	26
<b>Figure 2.18.</b> Historical arming sword replica of Europe (Bachmann, 2020).	27
<b>Figure 2.19.</b> Viking sword from 9th century Scandinavia (Petersen, 2005).	28
<b>Figure 2.20.</b> Illustration of a blacksmith hammering iron to shape (Moyer, 2018).	29
<b>Figure 2.21.</b> Medieval swordsmiths (Clements, 2006).	29
<b>Figure 3.1.</b> Painting of Minamoto no Yoritomo clan leader as shogun (Takanobu, 1179).	31
<b>Figure 3.2.</b> Samurai on horseback (Kuniyoshi, 2011).	35
<b>Figure 3.3.</b> Samurai armor (Tokyo, 2020).	36
<b>Figure 3.4.</b> Uchigatana in sheath, uchigatana, and uchigatana blade (Draeger, 1973).	37
<b>Figure 3.5.</b> Example of a yumi bow (DeProspero and Deprospero, 2012).	38
<b>Figure 3.6.</b> Tachi blade and mounting (Masatsune, 2020).	38
<b>Figure 3.7.</b> Different yari heads (Anonymous, 2014).	39
<b>Figure 3.8.</b> Example of a typical naginata (Armstrong, 2008).	39
<b>Figure 3.9.</b> Various parts of a Japanese sword (Swords, 2020).	40
<b>Figure 3.10.</b> Japanese sword descriptions (SBG, 2020).	40
<b>Figure 3.11.</b> Raw tamahagane steel (Loulas, 2008).	41
<b>Figure 4.1.</b> Fe-Fe <sub>3</sub> C phase diagram with specific compositions for 1075 and 1045 steels (Evelyn, 2019).	44
<b>Figure 4.2.</b> Fe-Fe <sub>3</sub> C phase diagram showing microstructures forming for different compositions (Velling, 2020).	44
<b>Figure 4.3.</b> Hypoeutectoid steel microstructure with proeutectoid ferrite grains and pearlite (Foll, 2005).	45
<b>Figure 4.4.</b> Eutectoid steel with a fully pearlitic microstructure (Hamada et al., 2011).	45
<b>Figure 4.5.</b> Hypereutectoid steel microstructure with proeutectoid cementite and pearlite (Dhafer, 2019).	45
<b>Figure 4.6.</b> 1075 and 1045 steel marked for cuts.	48
<b>Figure 4.7.</b> Vertical bandsaw.	48
<b>Figure 4.8.</b> Mounting the steel specimens.	49
<b>Figure 4.9.</b> The six specimens mounted in the “pucks”.	49
<b>Figure 4.10.</b> Grinding the specimens using different grit sandpaper.	49
<b>Figure 4.11.</b> A mirror polished specimen, demonstrating the reflectiveness of the surface.	50
<b>Figure 4.12.</b> Microstructure (pearlite) of 1075 steel in three planes (500x magnification).	50
<b>Figure 4.13.</b> Microstructure (ferrite and pearlite) of 1045 steel in three planes (500x magnification).	50
<b>Figure 4.14.</b> Fe-C phase diagram showing the microstructure evolution for a hypoeutectoid steel (Callister, 2014).	53
<b>Figure 4.15.</b> Lath martensite in 1524 alloy steel (Vander Voort, 2014).	54
<b>Figure 4.16.</b> Plate martensite with small amounts of retained austenite in 1095 steel (Vander Voort, 2014).	54
<b>Figure 4.17.</b> Tempered martensite in a HT9 steel (Klueh and Nelson, 2007).	54
<b>Figure 4.18.</b> Direct comparison between upper and lower bainite in carbon steel (Rohit, 2020).	55
<b>Figure 4.19.</b> Eutectoid iron-carbon alloy CCT diagram (Calister, 2014).	55
<b>Figure 4.20.</b> Final microstructure transformations on CCT diagram (Calister, 2014).	56
<b>Figure 4.21.</b> CCT diagram for 4340 steel with cooling rates and corresponding microstructures (Calister, 2014).	57
<b>Figure 4.22.</b> Microstructure of forged 1075 steel in three planes (500x magnification).	58
<b>Figure 4.23.</b> Microstructure of forged 1045-1075 combined steel (500x magnification).	58
<b>Figure 4.24.</b> Heat treated 1075 steel in three planes (500x magnification).	59
<b>Figure 4.25.</b> Heat treated 1045-1075 combination in two planes (500x magnification).	59
<b>Figure 5.1.</b> Tatara forge (Tatsuo, 2004).	61
<b>Figure 5.2.</b> Tamahagane welded and folded (JNTO, 2020).	62
<b>Figure 5.3.</b> Example of an industrial power hammer (Blacksmithing, 2014).	64

<b>Figure 5.4.</b> Example of a blast furnace (Parrott-Sheffer, 2020).....	65
<b>Figure 5.5.</b> Diagram of an electric arc furnace (Parrott-Sheffer, 2020).....	65
<b>Figure 5.6.</b> Example of a propane forge. ....	66
<b>Figure 6.1.</b> 1075 steel marked for plasma cutting. ....	68
<b>Figure 6.2.</b> Angle grinding the residual slag of the 1075 steel bar. ....	68
<b>Figure 6.3.</b> Small propane forge heating up. ....	69
<b>Figure 6.4.</b> Hammering the blade point on the anvil.....	69
<b>Figure 6.5.</b> Working the bevel down the length of the blade. ....	70
<b>Figure 6.6.</b> The final beveling towards the base of the blade.....	70
<b>Figure 6.7.</b> The results of beveling and widening the blade.....	70
<b>Figure 6.8.</b> The large propane forge with raising doors. ....	71
<b>Figure 6.9.</b> The power hammer striking the hot 1075 steel.....	71
<b>Figure 6.10.</b> The tang almost stretched out to full length.....	71
<b>Figure 6.11.</b> The sword after forging was complete.....	72
<b>Figure 6.12.</b> The metal cutting saw trimming off metal from the tang. ....	72
<b>Figure 6.13.</b> The blade with slight deformities after beveling. ....	72
<b>Figure 6.14.</b> Hammering the warm blade along the length of the anvil.....	73
<b>Figure 6.15.</b> The final product after blade was straightened.....	73
<b>Figure 6.16.</b> The grinding belt setup with the flat table attachment.....	73
<b>Figure 6.17.</b> The sword after one round of grinding and leveling the edges. ....	74
<b>Figure 6.18.</b> The tang being shaped into the blade.....	74
<b>Figure 6.19.</b> The tang after it was fully cut into the blade.....	74
<b>Figure 6.20.</b> Finished sword dimensions.....	75
<b>Figure 6.21.</b> Grinding sword bevels with wheel attachment.....	75
<b>Figure 6.22.</b> The sword bevel almost finished.....	75
<b>Figure 6.23.</b> Cross guard profile being grinded down.....	76
<b>Figure 6.24.</b> The blade with cross guard attached. ....	76
<b>Figure 6.25.</b> Final arming sword replica.....	76
<b>Figure 6.26.</b> 1075 carbon steel sample bar during normalizing cycle.....	77
<b>Figure 6.27.</b> Quenching the sample after austenitizing. ....	77
<b>Figure 6.28.</b> Bar of fused metals.....	78
<b>Figure 6.29.</b> Stretching and beveling the blade. ....	78
<b>Figure 6.30.</b> Blade with the misshapen tip removed. ....	79
<b>Figure 6.31.</b> Warped blade prior to straightening.....	79
<b>Figure 6.32.</b> Blade after curve was hammered out.....	79
<b>Figure 6.33.</b> Blade after carbon scaling was partially ground off.....	80
<b>Figure 6.34.</b> Final blade product after grinding.....	80
<b>Figure 6.35.</b> Final uchigatana replica. ....	81

## LIST OF TABLES

<b>Table 4.1.</b> Mechanical and physical properties of the hot rolled steels (Material Properties Database, 2020).....	43
<b>Table 4.2.</b> Spectroscopy results for both steels (averages of 4 measurements).....	46



# 1. INTRODUCTION

This project serves as an addition to The Historical Evolution of Arms and Armor Interactive Qualifying Project series. The purpose of this project is to examine the European and Japanese regions during concurrent time periods during the Medieval Era. This is done through the analysis of the European and Japanese political and cultural structure, as well as the technology of the weapons and armor of the time used by the respective regions.

Both the European and Japanese regions have a vast political and social history, which can give us a deeper understanding of the evolution of weapons and other technologies during the time period. This report first focuses on the history, weapons, and armor of the European region during the Late Medieval Period, with an emphasis on the origins and specific history of the arming sword. This is followed by the description of Japanese history, and the evolution of their region's weapons and armor, with specific focus on the uchigatana.

The second part of the report focuses on the replica construction of a European arming sword and a Japanese uchigatana. The process of constructing these two swords is discussed, with a focus on the materials' microstructures and properties of the respective weapons before and after their forging and subsequent heat treatment.

## 2. EUROPEAN BACKGROUND

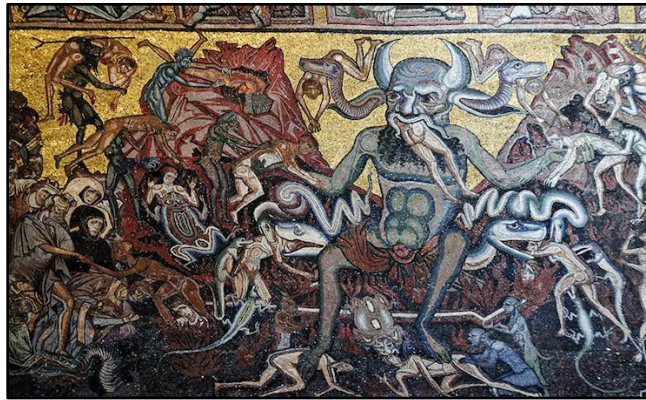
### 2.1. History

#### 2.1.1. Contextual Time Periods

##### 2.1.1.A. Late Medieval Age

Europe faced many of their most severe challenges during the 14th and 15th century, referred to as the Late Medieval Period. Plunged into a devastating bout of catastrophes, Europeans experienced religious dispute, war, plague, and famine. Some of these crises were so extreme that this period in history truly transformed human thinking and marked the decline of medieval society. The Babylonian Captivity of the Papacy, also known as the Avignon Papacy, marked the beginning of these events in 1309 AD. This refers to the roughly 70 years where all the consecutive popes chose to reside in a town in France called Avignon rather than the traditional place of Rome (Drees, 2001). While not of malicious intent, the absence of religious authority was inconceivable by the general population and became the spark for religious strife in years to come. Another major event of the late medieval period was the Hundred Years' War between the kingdoms of England and France. Rather than one large conflict, the war was a culmination of many battles and lesser conflicts that lasted from 1337 to 1453 AD. Regarded as one of the first modern wars, the Hundred Year's War lay waste to European citizens and land alike (Cartwright, 2020). Finally, and possibly the most devastating event in all of European history; the Black Death pandemic. Reaching its worst in the years 1347 to 1351, the Black Death was the one deadliest disease of human history and killed over 25 million people. Relative to the much

smaller European population at the time, it is estimated that the Black Death killed anywhere from one to two thirds of all Europeans.



**Figure 2.1.** Dante’s mosaic in the Florence Baptistry 13th century (Collins, 2015).

As seen in the mosaic in Figure 2.1, the times were defined by grotesque imagery and many other artistic pieces from this era convey the same sense of chaos and hopelessness. Due to the anarchic events of the Late Medieval Age, this period was chosen from the larger scope of European history as the historical setting for the weapon of analysis. Tensions and wars were at their pinnacle while combat technologies remained traditional with heavy reliance on melee weapons such as the arming sword. To better understand the culture, technology, conflict, and future shaping events of the Late Medieval Age, it is important to acknowledge its place on the larger timeline of European history.

### **2.1.1.B. High Medieval Age**

The Late Medieval Age was preceded by the High Medieval Age which many scholars believe represented the peak of Medieval civilization. Beginning around the 11th century and lasting until the 14th century, the High Medieval Age bore witness to countless important events. These included the Norman conquests in Britain and Sicily, the Early Crusades, and the signing of the Magna Carta. Feudalism was established across nearly all of Britain as well as other parts of Europe, creating a defined social structure and allowing trade to flourish. This would not last forever, as numerous cataclysmic events would occur in the 14th century, signaling the end of the High Medieval Age.

### **2.1.1.C. The Renaissance**

Scarred from the events of the Late Medieval Age, Europe experienced a complete rebirth of society and human thinking in what became known as the Renaissance. This period took place from the 14th century to the 17th century and served as the bridge between the medieval ages and modern society. The Renaissance was defined by a mass cultural shift in Europe towards the disciplines of art, politics, economy, and science. This was only natural seeing that the turmoil of late medieval Europe left a massive void in society waiting to be filled by new ideas and philosophies. It sparked a new awareness of the surrounding world and man’s place within it, originating as Humanism in 14th century Italy. This was a movement where humans recognized and rewarded man’s achievements in education, classical arts, literature, and science (Sullivan, 2018). Utilizing the capabilities of the Gutenberg printing press in 1450, the spreading of ideas inspired many individuals to seek accomplishments that

would better society. Another enabling factor for involvement in the arts and sciences was the Medici Family of Florence, Italy. They had both the wealth and power to support newly proclaimed artists, writers, and politicians which gave huge traction to the movement.



**Figure 2.2.** School of Athens by Raphael 1509 (Sanzio, 2013).

Even though the origin of the Renaissance was in Italy, it quickly spread through all of Europe and facilitated the birth of many distinguished individuals of the era. Leonardo da Vinci (1452-1519) was an Italian painter that is famous even today for his astounding feats in art, architecture, and science with one example being the painting “Mona Lisa”. Michelangelo (1475-1564) was an Italian sculptor and writer responsible for the statue of David and other works that have greatly inspired Western art. Rene Descartes (1596-1650) was a French philosopher who is considered the founder of modern philosophy and additionally made breakthroughs in the fields of math and science. These are just a few of the countless influential Renaissance figures that define the new ideas and cultural focus of this era (Sullivan, 2018). With a brief understanding of the advancements and civilization restructuring of the European Renaissance period, this project brings the focus back towards the Late Medieval period. The widespread conflict, unrest, and chaos of this time better serves as the framework to study the rudimentary yet essential arming sword.

### **2.1.2. Important Nations**

During the Late Medieval Ages, Europe saw several influential powers and figures that would become an essential part of understanding the social and cultural landscape of the time. Of all the powers during the time period of 1300-1500, England, France, and Hungary proved to be the most dominant in the European region.

#### **2.1.2.A. England**

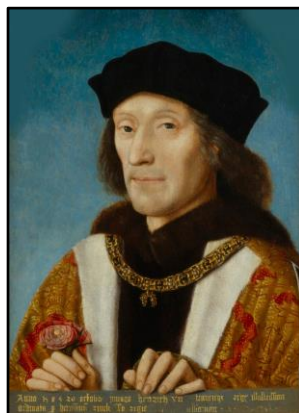
At the onset of the Late Medieval Ages, King Edward I would begin his reign after the death of Henry III. During his reign, Edward’s military experience would see him drive out the Prince of Wales and establish the nation under the rule of England. In doing so, he established one of the largest armies which England had ever assembled, fortifying the kingdom’s military strength (Treharne, 2020). Domestically, Edward would use his authority on the Church to establish more power for the Crown. Edward would also expel the Jews from England to eliminate various debts, and this decision was very

popular at the time. Conflict would arise between England and Scotland when Edward I invaded Scotland after Scotland became allied with France in 1296. Several domestic issues plagued the Anglo-Scottish wars, and Edward I would die before the war's end.

Edward I was succeeded by his son Edward II who was also faced with numerous domestic issues, notably a large famine. Edward II would lose in the Battle of Bannockburn against the Scots, now led by Robert the Bruce, which would be remembered as a humiliating defeat (Manning, 2020). Edward's relations with France were not much better. He would be taken advantage of by Queen Isabella of France and eventually abdicated his throne. Queen Isabella would assume power for 4 years, but this would end in 1330 when she was overthrown by Edward III, son of Edward II. In 1338, Edward III would sign a truce with the Scots, effectively ending the Anglo-Scottish War.

The Hundred Years' War would begin in 1337 and would see France and England involved in a brutal war that would last more than a century (Keen, 2011). The Black Death would also strike England in 1348 and would ravage the entire kingdom. The plague halted any campaign plans which Edward III had, as nearly  $\frac{1}{3}$  to  $\frac{1}{2}$  of the English population perished because of the plague. War with France would resume in 1356 when Edward Prince of Wales, son of Edward III, launched a campaign that would result in numerous successful conquests of French territory (Keen, 2011). Both Edward III and Prince Edward would die before the wars end, leading to the 10-year-old Richard II succeeding the throne. A Peasant's Revolt would occur in 1381 in response to numerous unfavorable economic policies. Richard II would be deposed in 1399 and the title of king would be assumed by Henry of Bolingbroke, or Henry IV.

Henry IV would die in 1413 and be replaced by his son Henry V. Henry V went to war with France and had several successful campaigns but would die of dysentery in 1422, with the throne passing on to Henry VI. At this time, Joan of Arc would become involved in the war, creating a turning point in the campaigns against the French (Keen, 2011). While Joan was captured and burned at the stake in 1431, the weak leadership from Henry VI would put England in a difficult position within the ongoing war. Unrest within England would lead to a civil war known as the War of the Roses in which House York fought against House Lancaster. This war would see a few power struggles, with Henry VI being replaced by Edward IV (Britannica, 2020). Henry VI would later reassume the throne but in 1470, however he would be murdered in 1471, leaving the throne open for the House of York to assume power. Edward V would be declared king, but Richard III would seize power over him in 1483. This reign would also be short lived, with Henry Tudor invading in 1485, laying waste to Richard III and seizing the throne for himself, becoming Henry VII; concluding the history of the late Medieval Ages in England.



**Figure 2.3.** King Henry VII of England (Sittow, 2019).

### 2.1.2.B. France

Prior to the Late Medieval Ages, France had begun to develop a strong relationship with the papacy. At the turn of the century, this relationship was put to the test when issues arose between Pope Boniface VIII and King Philip IV concerning clergy tax matters. Tensions arose and in 1303 the Boniface was arrested and held prisoner for 2 days. This would leave a resounding effect on the relationship between the church and the kingdom, with Philip IV becoming more powerful. For much of the 14th century, the papacy was subservient to France, with seven popes being of French origin. The headquarters of the pope would be moved to Avignon during this same time period. In the years following Philip IV's death in 1314, the two successive Kings both died within a span of 8 years. Charles IV would become the new king and during his reign, France saw a steady population growth, with the kingdom having the largest population of any rival kingdom in the area (Gascoigne, 2001). When Charles IV died without an heir, the next in line of succession was Edward who was the son of Charles IV's sister Isabella. However, Edward, also known as Edward III, was king of England. France would not allow an English king to be king of France, so the succession descended to Charles IV cousin Philip, crowned Philip VI (Gascoigne, 2001). This decision, along with territorial factors, would lead to the start of the Hundred Years' War.

Philip's reign was not only complicated by an emerging war, but by a plague of catastrophic scale. The Black Death tore through Europe and eviscerated enormous populations. Due to the outbreak of disease, no major offensives occurred until after 1355. Numerous battles would take place during the war following the Black Death, many of which the English would win. During the Battle of Poitiers in 1356, the reigning king John II would be taken prisoner by the English (Gascoigne, 2001). After four years John II would be freed after a hefty ransom was paid by the French, however he would return to London voluntarily, where he died. Charles V would succeed John II, and as a king proved to be more prone to diplomacy rather than direct conflict. Charles V would become known as "Charles the Wise". His son Charles VI would become known as "Charles the Mad". Charles VI would rule for several years until bouts of violent madness resulted in the crowning of Philip the Bold. His death in 1404 would result in a rivalry, followed by civil war because of two nobles who were vying for power (Gascoigne, 2001). One of the nobles had the other murdered, resulting in a civil war. At the same time, Henry V, the king of England began to resume tensions within the Hundred Years' War.

John the Fearless, the noble who instigated the murder that launched the civil war, attempted to negotiate peace but was murdered. Charles VII, the son of Charles VI, declared himself regent king, while Henry V was arranged in a marriage that would ensure that his son (Henry VI) would become king. When Henry V died, his son was only 10 months old and could not assume the throne while Charles VII was confined to Southern France as England invaded the Northern French territories (Gascoigne, 2001). In Orléans in 1429, a young girl arrived with a French force to raise the English siege. This girl was known as Joan of Arc and her victory in raising the Siege of Orléans provided national enthusiasm to push back against the English forces. Charles VII would be consecrated, unifying the French people under a single ruler.

Following his return to the monarchy, Charles VII improved France's revenues and strengthened its military. His military fortification would prove vital in victories towards the end of the major conflicts in the Hundred Years' War. In 1461, Louis XI would succeed Charles VII, and in 1475 he would bring the Hundred Years' War to an end through negotiations with Edward IV (Keen, 2011).

Louis XI would leave France in much better political and economic standing than it had been in several years. This would change when Louis XI handed power to his son Charles VIII. Charles VIII was a young king and had romantic ideas of claiming the throne in Naples. Campaigns in Italy followed which had no beneficial effect on the kingdom. Charles VIII would ultimately die in an accident in 1498, bringing an end to the Late Medieval Ages in France.



**Figure 2.4.** Charles VIII of France (Longueville, 2020).

### 2.1.2.C. Hungary

At the beginning of the Late Medieval Age, the Kingdom of Hungary was in a transition between regimes of power. King Andrew III had just died and numerous oligarchs who were independent within the kingdom had the opportunity to strengthen their self-governance. Charles of Anjou would be crowned king in 1301 as Charles I. Due to the number of territories removed from royal control, Charles launched expeditions against the oligarchs and defeated all of them (Lambert, 2015). In the 1320s, Charles introduced a centralized power structure as well as several economic and monetary practices. Charles I would die in 1342 and would be succeeded by his son Andrew who was assassinated in 1345. Louis I would acquire power over the throne and would attempt to launch a campaign in Naples that was cut short. The Black Death would strike in 1346, however Hungary remained less affected than its Western counterparts due to a smaller and more spread-out population (Engel, 2001). Louis I would move south after the plague to encourage other nations to accept his suzerainty. In 1360 Louis I expelled the Jews from Hungary while trying to convert any Orthodox Christians to Catholicism.

Upon his death, Louis I's daughter Mary was made queen. Charles III of Naples, a male member of the dynasty, opposed Mary and took power over the throne. He was murdered by loyalists of Mary. Ultimately Mary's husband Sigismund was made king. In the coming years, the Ottoman Empire's influence was growing and nearing the Hungarian borders. Dissent would arise within Hungary in the early 1400s leading to Pope Boniface IX supporting an opponent to Sigismund's rule. In response, Sigismund outlawed any proclamation of papal documents without royal consent (Engel, 2001). The threat of the Ottoman Empire was ever present during this time and prompted Sigismund to grant land to other rulers to put buffers between Hungary and the Ottomans. When Sigismund died in 1437, he had no sons, and a civil war followed after dissent between potential successors. Eventually, the son of Sigismund's son-in-law Ladislaus V was recognized as the successor, but regency was placed with John Hunyadi, a successful military leader. Hunyadi would resign from the regency and Ladislaus would be overseen by Ulrich II. Ladislaus would flee to Prague in 1457 where he would die that same year.

In 1458, Matthias Hunyadi, son of John Hunyadi, would be crowned king and would introduce fiscal and military reforms. Hunyadi began attacking foreign lands such as Bohemia and Poland instead of the Ottoman Empire to gain allies to eventually defeat the Ottoman Empire. This new offensive direction was unpopular and there was a rebellion in 1471 against Matthias, which he overcame with ease. Following his death in 1490, Matthias' previous reforms would not stay in place for long. An oligarchy gained control of Hungary and oversaw the succession of Vladislaus II, the king of Bohemia, who was infamously known for blindly accepting any proposal put before him (Engel, 2001). Naive economic and military policy would ultimately be the downfall of the prosperous Hungarian kingdom. Peasant revolts plagued the kingdom and when the Ottomans finally invaded, the Hungarian military force was woefully unprepared. The kingdom would ultimately fall to the Ottomans in the years to follow.



**Figure 2.5.** The Siege of Constantinople (Le Tavernier, 1455).

### **2.1.3. Major Events**

#### **2.1.3.A. The Avignon Papacy (1309-1377)**

Starting the turmoil of the late medieval period, the Avignon Papacy was the event in 1309 AD that sparked years of religious strife. This event, also known as the Babylonian Captivity of the Church, was the approximately 70-year period where all the consecutive popes chose to reside in the French city of Avignon. While seemingly innocent in nature, it was shocking to the public that the papacy took permanent residency outside of Rome. The presence of such religious authority had become expected and almost a necessity to ensure a strong faith among the masses. The first pope to make the permanent move to Avignon was Pope Clement V, who had become convinced by the French King Philip IV that the papal capital should be moved to France (Ray, 2008). It is notable that all 7 popes during this period of the Avignon Papacy, including Pope Clement V, were originally from France. The newly appointed cardinals were also overwhelmingly French outnumbering the entire cardinal body of the Sacred College

of Cardinals 112 to 22. The reason this was such a serious affliction for medieval European society was that the foundation of religious faith relied on the strong reputation of the papacy. With the robust shift of power to France and consequent stacking of the Sacred College of Cardinals, nations such as England, Italy, and Germany grew opposed. Especially after the start of the Hundred Years' War, England viewed the papacy aligned politically and financially with the enemy and made this distrust clear to the nation (Concordia, 2016). Overall, the simple move of 7 consecutive popes to France completely waived the faith of medieval society and served as the catalyst for much future conflict/crisis of the late medieval period.



**Figure 2.6.** Palace of the Pope in Avignon, France (Unknown, 2019).

### **2.1.3.B. The Great Famine (1315-1322)**

One of the first major crises of late medieval Europe, the Great Famine lasted from 1315 to 1322 and led a series of successive famines for many years to come. The Great Famine by far was the largest of the famines and influenced life in almost all of Europe including Ireland, England, France, Germany, Scandinavia, Italy and even parts of Asia. At the start of the Great Famine in the year 1315, there were large amounts of rainfall that caused widespread flooding of the crop fields. This rainfall was so drastic that it washed away communities along the shoreline due to rising water levels. As a result of the severe rain that continued in the following years, the farm animals and crops were devastated. It is estimated that the food production of wheat and all other crops were cut in half. Animals such as cattle and sheep developed diseases that left animals debilitated or dead. These diseases that killed livestock everywhere were grouped into one medieval term known as “murrains” (Merriam-Webster, 2020). With crop and animal food sources wiped out, many settlements across Europe were abandoned by the peasants who were forced to roam in search of sustenance. The Great Famine did not just take its toll on peasants but affected everyone who lived in Europe including the upper-class nobility and church. All economic and religious power that exercised over kingdoms and feudal lands was negated by the extensive lack of food and large death toll. The Great Famine also led to an influx in hostility, crime, and war. With already many ongoing conflicts, the famine enhanced tensions and anger across Europe with people forced to commit heinous acts to protect/provide for their families (Rosen, 2019). However, the worst was yet to come as the already weakened and violent population would soon have to battle with disease on a scale like never before.



### 2.1.3.C. The Black Death (1346-1353)

The next crisis was one of most devastating events in European history: The Black Death pandemic. The Black Death killed over 25 million people which makes it one of the worst diseases in all human history. During the late medieval period when Europe was already suffering from growing tensions between nations, warfare, and famine, the Black Death was truly the nail in the coffin. It started in 1346 when Mongolian warriors developed the bacterial disease from rodents in what was the first major outbreak of the Black Death. It then passed through the Black Sea to the outpost of Caffa as the Mongols attacked, who even hurled the infected bodies of their fallen soldiers over the walls. It was from here that Caffan trade ships brought the disease to main populations of Europe leaving a wake of death in their path. By the end of 1349, the majority of Europe had suffered from the Black Death including France, Spain, England, and Ireland. Later in the peak of the disease around 1352 it had reached Germany, Scandinavia, and even Russia (Seven, 2020). The reason it spread so rapidly and extensively was that this was a bacterial disease unlike anything “medical experts” of the medieval period had ever seen. There was no treatment knowledge, and the standards of public health were so terrible that it provided the perfect environment for the Black Death to wreak havoc on Europe. It also was fueled by the already exhausted population that in a panic, would flee from outbreak locations and inadvertently spread the disease further.



**Figure 2.7.** Mural of “The Triumph of Death” of the plague (Forman, 2020).

After seven years of suffering from the Black Death, in 1353, the disease faded out. However, the effects of the severe death toll and social consequences could be seen in Medieval Europe for centuries after. Roughly 30-50% of the population infected by Black Death were killed with fluctuations dependent on environment and living standards. The social consequences of such a quick drop of population were immense and the structure of society was truly left broken. The credibility of all different kinds of “authority”, including nobility and religion, were tarnished as citizens sought to place blame for the unceasing death. This chaos and breakdown of society continued for years and ongoing/future events such as the Western Schism were only amplified by the Black Death (Cartwright, 2020).

### **2.1.3.D. The Western Schism (1378-1417)**

The Western Schism, also called the Great Schism was the one of the last major events of the Late Medieval period and started in 1378. This great authority crisis directly succeeded the events of the Avignon Papacy that ended in 1377 and would be the toughest challenge the medieval church ever faced. At this time, Gregory XI was elected pope on the promise that he would bring the papacy back to its original glory in Rome. While he did briefly fulfill this promise, Gregory XI's unexpected death in 1378 started a snowball effect that would forever disrupt the high status of the papacy. The new pope to take his place was an Italian named Urban VI, who achieved support by taking a stance against the majority French religious control that had resulted from the Avignon papacy. The Sacred College of Cardinals were appalled by this notion and all but a few Italians retreated to France, as they sensed it was their best possibility to maintain power (Canning, 2011). Once arriving back in the French city of Avignon, the cardinals discredited pope Urban VI in Rome and appointed a second pope named Clement VII. This radical move of the French cardinals would entirely split the medieval church in Europe and create two pope lineages: Roman and French. However, with the ongoing Hundred Year's war already high tensions between nations, a strong rivalry of religious authority began. Pope Urban VI in Rome was backed by England, who was at war with France, and the Germanic Holy Roman Empire. Pope Clement VII in Avignon was supported by the Spanish and England's rival of Scotland. Overall, this was hugely destructive because it not only upset what little religious faith the public had left, but it also took away all authority and economic stability of the medieval church. Society was exposed to the true desires of the papacy that were the worldly glories of power and money. This lasted years as countless groups tried to remedy the innate corruption of the church by unifying the papacy to no avail. It only made matters worse as in 1409 the Council of Pisa elected a new pope, Alexander V, to depose the existing two papal lines and instead just created a third pope. It was not until 1417 that the Council of Constance finally resolved the Western Schism by accepting the Roman line's claim to papacy (Seminary, 2014).

### **2.1.4. Wars/Conflicts**

Battles and wars have always been a staple of different conflicting civilizations since the beginning of time. This notion certainly held true in the Late Medieval Era. While the size of conflicts ranged from small foot battles to large scale mobilizations, no conflict better exemplifies warfare during the Late Medieval Era than the Hundred Years' War.

The Hundred Years' War was one of the longest lasting conflicts in known human history, starting in 1337 and ending in 1453. The roots of this conflict can be traced back to the challenge of the French throne by Edward III of England following the death of Charles IV. Tensions between the two kingdoms had existed long before this incident, but it proved to be the spark in the proverbial powder keg. Edward III used his claim to the throne to gain allies within France who were discontent with their current rule. He was able to find allies in the Flemings and several French nobles (Gascoigne, 2001). With these alliances Edward was able to keep certain French territories isolated from French rule.

In 1346, Edward III would lead the English to victory over the French at the Battle of Crécy and would follow this with a successful siege at Calais (Keen, 2011). Edward's heir known as the Black Prince would lead two successful offensive attacks on the French. One of these was the Battle of Poitiers, which resulted in the capture of John II, successor to the French throne. Holding the French king for

ransom, in 1360, Edward was able to negotiate for a large portion of money in addition to French land, under the condition that he renounced his claim to the French throne.

Peace lasted for 9 years until French and English disputes resulted in the renegeing of the negotiations made years prior. While hostility remained present between the two kingdoms, both were war weary and both countries attempted to negotiate peace. In 1413, the English king Henry V seized the opportunity to attack France when civil war plagued their country. Henry launched numerous sieges to conquer territory in 1417. At this point in the war, England was poised to take over a large portion of France with very few obstacles in their way. Northern France sought to negotiate a peace treaty with England while Southern France remained in opposition.

In 1429, Joan of Arc would arrive at the French prince's court speaking of divine intervention instructing her to purge France of the English (Gascoigne, 2001). Later in the year with a relieving army, Joan marched on Orléans and successfully broke the siege. Further victories would follow when Joan defeated retreating English forces, until she was burned at the stake in 1431. Charles VII would be recognized as king in France following the victories. In 1444, a general truce was reached between the French and English but was broken when English forces sacked a commune in French territory. This resulted in Charles VII retaliating from 1449-1451 during which time he overran Normandy. On July 17, 1453, the war was ended when the English army was defeated at Castillon and their commander killed (Gascoigne, 2001). While more conflict ensued between the French and English, this date effectively marked the end of the conflict that became known as the Hundred Years' War.



**Figure 2.8.** Battle of Crécy in 1346 (Ancient History Encyclopedia, 2020).

## **2.2. Arms and Armor of the Late Medieval Period**

During the late medieval period, the variety of soldiers and their respective weapons was quite vast. As this was the peak of the medieval era conflicts, the soldiers and weaponry of the time had evolved to keep pace with the desire of nations to be victorious in combat.

## **2.2.1. Classification of Soldiers**

Just like Medieval society, when in warfare, there was a hierarchy that was followed. This hierarchy was typically determined by the social status of the individual, and then by certain skills which the individual was proficient in.

### **2.2.1.A. Monarchs**

One of the most important attributes of a monarch in the medieval era was their ability to wage war and achieve glory on the battlefield. Whether it was a king, prince, or feudal lord it was expected that the monarchs be at the forefront of battle. They would lead their soldiers and serve as the acting commander in the conflict, relying on their Nobles to enact full control over their forces composed of knights, mercenaries, and archers (Franklin). Monarchs were armed with the highest quality of arms and armor to convey their renown status among the ranks. They would also commonly wield mighty and awe-inspiring weapons such as two-handed great swords as a display of their vast power. While Monarchs were a quintessential component of a combatant's war strategy, they also became a critical weakness requiring constant protection. An example of this flaw was seen in the capture of French King John II during the Hundred Years' War. His capture meant the remaining French battle strength was greatly depleted and ultimately led to their surrender (Ryan, 2016).

### **2.2.1.B. Nobles**

The classification of Nobles in medieval combat were men such as barons, earls, and dukes who ranked directly below monarchs. Nobles would follow their monarchs' orders in combat and act as the organizing force for greater composition of soldiers. Each Noble was expected to bring their own group of knights, mercenaries, and whoever else could accompany them to battle. Like Monarchs with arms and armor, Nobles were typically armed with the highest quality gear and large two-handed weapons that displayed their great strength. They also were a key target for enemies as the capture of a noble could often mean ransoms or other negotiation incentives (Ryan, 2016).

### **2.2.1.C. Knights**

The most iconic soldier of the medieval period was the Knight. These were men ranked below Nobles and expected to carry out their orders on the frontline of battles. Responsible for being the elite members of larger companies filled with the likes of mercenaries, Knights waged combat with their signature plate armor, sword, and horse. Being a Knight meant more than just excelling in combat however and was truly an elite way of life. To become a knight a man must both come from great wealth to afford their own armament and start training as a young boy. Into the late medieval period, becoming a knight was a great honor and could grant admission into esteemed brotherhoods such as the chivalric Order of the Garter (founded 1348). Knighthood was so acclaimed that this medieval style lasted well into the Renaissance era and faded around the 17th century. It also gave rise to many famous individuals who gained reputations across Europe such as "Bertrand du Guesclin" and "Sir William Marshal" (Cartwright, 2018).



**Figure 2.9.** Tapestry depicting a 13th century German knight (Manesse, 1305).

### **2.2.1.D. Mercenaries**

Also known as routiers, the term mercenary began to develop a stigma due to the perceived notion of lack of loyalty (Williamson, 2017). These men would act independently of any government or power. Often banded together as a “company” these companies could be hired by a power to provide military assistance in return for compensation. As military compensation within regional powers became more commonplace, the mercenary became less common as the Late Medieval Ages progressed.

### **2.2.1.E. Archers**

Archers were a vital part of the military unit during the Medieval Ages, from both the offensive and defensive perspective. There were countless military scenarios that would warrant a ranged attack. Due to the high usage of melee weapons during the time period, being able to attack your opponent from a distance was a clear benefit when fighting with a bow. Archers could be separated into two categories in the Medieval Ages: a longbowman or a crossbowman. Both weapons have clear advantages and disadvantages which are addressed in section.

## **2.2.2. Armor**

Just as weapons are a vital component of warfare to attack your opponent, armor was just as essential. If you lacked bodily protection, an armed opponent would be able to make quick work of you. There is a clear trend between the evolution of weapons and the armor used in specific historical periods. During the medieval era, melee weapons would be the predominant type of weapon used. As such, the design of the armor would provide optimal protection against this type of weapon.

### **2.2.2.A. Plate Armor**

Full plate armor would develop from steel plates which were added into various armor components around the 14th century (Roberts, 2019). Full plate armor would become commonplace in the 15th century, often worn by knights. This armor was made from overlapping steel plates that

provided excellent protection against blunt strikes and stabs alike. The largest drawback of plate armor was that swords could be thrust within the gaps in the armor. Any soldier wearing full plate armor would be a formidable opponent in battle.



**Figure 2.10.** Plate armor circa 1450 (Missaglia, 2012).

### **2.2.2.B. Chain Mail**

Chain mail armor was one of the most rudimentary forms of metal armor that saw use during all periods of the Middle Ages. This armor was useful for providing protection against cuts and slashes from weapons such as swords, spears, and axes. It was also lightweight, easily repairable, and soldiers could move with ease. Chain mail armor was ineffective in providing protection from any weapon which utilized blunt force trauma. By the 14th century, the use of chain mail armor became more infrequent due to the development of plate armor (Alchin, 2015).



**Figure 2.11.** Chain mail specimen circa 1361 (Sauber, 2007).

### **2.2.2.C. Shields**

Shields were a vital source of protection for soldiers engaging in both melee and ranged combat. Shields could be made out of a vast range of materials, the most common of which were wood and animal hide. As the time period progressed, metal would become the preferred material to use in shield fabrication. The shield a soldier used depending on what their purpose in combat was. If the soldier was required to be mobile and quick on their feet, they would likely have a smaller and lighter shield to improve mobility. Likewise, if an archer were to use a shield, they would be able to afford a larger shield that would provide them with greater bodily protection. The application of shields in warfare were countless, and both design and material varied depending on said application. Shields would remain an essential part of medieval warfare and onwards until the widespread use of gunpowder.

### 2.2.2.D. Horse Armor

Horses were a large advantage in battle, but the odds of the horse surviving, they would need armor to protect themselves. Due to the size of the horses bred for battle, the armor itself would be extremely large, heavy, and expensive. It would not be until the end of the Late Middle Ages that horse armor would become a staple of heavy cavalry warfare. Mirroring developments in soldiers' armor, the horse could be outfitted with leather armor, but as time progressed, the adoption of plate armor for the horse occurred.

### 2.2.3. Melee Weapons

The late medieval period was defined by the utilization and craftsmanship of melee weapons. In the 14th and 15th century ranged weapons were still rudimentary and any minor developments of firearms were still flawed. As a result, melee weapons such as swords, polearms, and daggers were at the forefront of many wars/conflicts.

#### 2.2.3.A. Swords

Of all the melee weapons used during the Medieval Ages, the sword was one of the most used. While not used as much by the common foot soldier, the sword was associated with the knight. The types of swords used during this era ranged from smaller swords of about 76 centimeters in length to great swords of more than 175 centimeters in length. Depending on the design of the sword, it would be optimal for either stabbing or slashing. The sword was viewed as symbolic by many, taking a deeper meaning outside of warfare, and would be inscribed by a smith to have value to the sword bearer.



**Figure 2.12.** Replica of a medieval era sword (Niedziella, 2011).

#### 2.2.3.B. Spears, Pikes, Halberds

Spears were another popular melee weapon during the time, but contrary to swords, were more often wielded by the typical foot soldier or peasant. The spear was designed primarily for thrusting although it could be thrown in certain situations. The spear was also much cheaper to produce than a sword while requiring a lot less training. Variants included pikes, halberds, and other long weapons designed primarily for thrusting over a longer range than a sword.



**Figure 2.13.** Medieval polearms (Universe, 2015).

### 2.2.3.C. Daggers

Used as a sidearm for many soldiers, the dagger was a secondary weapon that could only be used in close combat due to the length of the blade. Daggers provided an added benefit of being able to stab between gaps in plate armor as the use of plate armor became more widespread. Daggers could also be employed to cut away armor straps and other equipment if needed.

### 2.2.4. Ranged Weapons

While not as prevalent and admired as melee weapons during the late medieval period, ranged weapons still played a critical role of every strong combat force. Due to the still evolving ranged weapon category, there were only a few forms they took during this era. They were also used in tandem with melee wielding soldiers as it added attack power and protection to the frontlines. Sometimes ranged weapons proved to even outclass melee weapons in some scenarios as archers. Especially displayed by the English during the Hundred Years' war, their distinguished use of the longbow was the deciding factor of their victories at Sluys, Crecy, and Agincourt (Medievalist, 2015).

#### 2.2.4.A. Longbow

As ranged weapons are concerned, the longbow was the most prevalent form during the late medieval period and saw heavy use during the Hundred Years' War. Archery was no new concept in Medieval Europe with some of the first bow and arrows being used as early as 3,000 BC in Ancient Egypt (Archery, 2018). With thousands of years of refinement and practice, archery became a status quo of society and soon gave rise to new iterations of the bow. The longbow was exactly that and was a relatively new weapon of Medieval Europe. Due to its towering height of about 6 feet and fabled power, it became a staple weapon during the late medieval. It is estimated that the typical draw strength of a medieval longbow was about 100 pounds which allowed this weapon to send the iron tipped arrows



downrange with devastating effect. Due to the longbow, armor such as chainmail was almost nullified as a well-placed arrow could pierce through the toughest mail and even kill horses. It was also so effective because Longbows were so easy to construct only requiring wood such as yew and bowstrings made of flax/hemp (Medievalist, 2015).



**Figure 2.14.** An English longbow representative of the time period (Cram, 2007).

#### **2.2.4.B. Crossbow**

The crossbow was an ideal ranged weapon because it required minimal training to use. The crossbow string could be loaded using either a lever or a cranking mechanism. The crossbow would use a bolt made from metal instead of a wooden arrow. Generally, crossbowmen were on par with a foot soldier as a lot less training was required for a crossbow than a longbow. With this being said, the crossbow was considerably less accurate than its longbow counterpart.



**Figure 2.15.** Medieval crossbow circa 1500 (Mohr, 2016).

#### **2.2.5. The Arming Sword (Knightly Sword)**

The Medieval arming sword, also known as a knightly sword, would see common use throughout the High Medieval Age into the Late Medieval Age. The arming sword was typically around 76-90 centimeters in length, could be wielded with one or two hands, and was often paired with a shield. By the Late Medieval Age, the sword was primarily used as a sidearm for knights as a larger weapon would be the primary weapon. Depending on how the blade was forged, combat styles could rely on blunt force trauma or rely on thrusting.

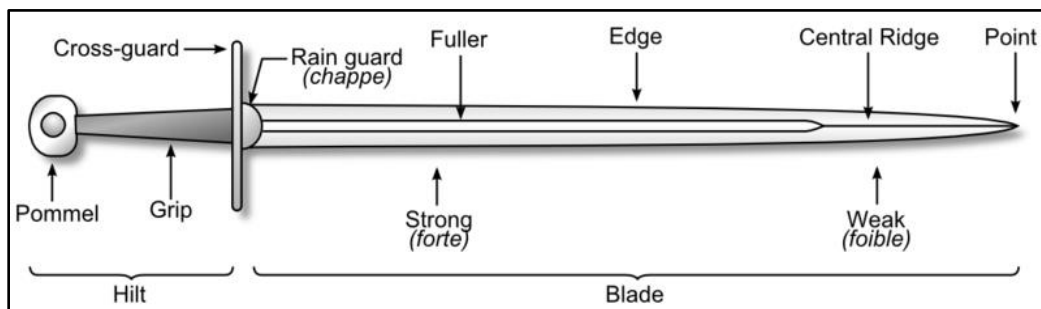
The arming sword would see use all over Europe during the Medieval period, from crusades to the Hundred Years' War. Numerous blacksmiths would create their own variants of the arming sword leading to a variety of pommel, hilt, and blade inscription designs that made each arming sword unique.



**Figure 2.16.** Bristol medieval arming sword (Suttles, 2017).

### 2.2.5.A. Design

The defining features of the arming sword are its broad, evenly tapered blade with full metal cross-guard. Scaled down in comparison to the fuller of a late medieval great sword, the arming sword has a much shorter fuller typically running only 1/3 to 2/3 of the blade length. The blade itself is double edged and commonly only tapered near the end of its length where it gradually curves to meet a sharp point. This basic yet sturdy design led to the arming sword being one of the most iconic weapons of the medieval period, especially concerning its close association with knights. The basic overall design standard of the arming sword also allowed for many blacksmiths to add unique flairs which will be further explored when concerning its widespread use across Europe (Albion, 2020).



**Figure 2.17.** Arming sword design diagram (Oakeshott, 2013).

### 2.2.5.B. Location

Due to its ease of construction and simple design, the arming sword saw development and use across all of Europe. This includes all the major medieval nations of England, France, Hungary, Germany, Italy, and many more. This created a common sword with unlimited design iterations as more blacksmiths and forges added unique elements. Especially concerning the pommel, hilt, and cross guard there are thousands of unique relics from the medieval era showcasing different sophistications. The blade of the arming sword remained relatively similar in design throughout medieval Europe besides elements such as inscriptions/etchings (Strongblade, 2020). Examples of these different designs corresponding to geographical regions can be seen in Figure 2.18.



(a) French 12th century replica



(b) Swedish 13th century replica



(c) German 15th century replica



(d) English 15th century replica

**Figure 2.18.** Historical arming sword replica of Europe (Bachmann, 2020).

### 2.2.5.C. Utilization

As previously discussed, the arming sword was a relatively small weapon (30-40") when compared with many of the other melee weapons in the late medieval period. This made the arming sword often classed as a secondary weapon, that was equipped at the side of men in combat. It saw extensive use being wielded by soldiers ranging from the average medieval foot soldier or knight all the way up to nobles and monarchs (Woosnam-Savage, 2020). Understandably, the quality and prestige associated with the weapon would scale in conjunction with the status of its wielder, with monarchs having the most expensive and luxurious arming swords. This secondary weapon was also not heavy at all, making it the perfect blade for extreme close combat. The pommel of the arming sword comprised a good portion of the overall sword weight enabling the user to have a good balance in their hand and make swift attacks. The dual blade edge allowed for slashes while the sharpened tip of the arming sword enabled targeting of an opponent's weak points. This was common as the most used armor in medieval Europe was plate armor, so the arming sword could be thrust between its gaps (Woosnam-Savage, 2020). Overall, the arming/knightly sword was a reliable and classic melee weapon that saw use in all of Europe for most of the medieval era.

### 2.2.5.D. Origin of Weapon

Due to the widespread use of the arming sword, there was not one point or place in time where the origin of the weapon can be found. Rather the arming sword was an evolution from earlier more primitive one-handed weapons. The sword developed from the ninth century Viking sword, with the

new transitional sword blade becoming narrower compared to the length of the sword. The arming sword became defined by the cross guard that was not present in its predecessor's designs. The Vikings during the ninth century inhabited the region known as Scandinavia which can be seen below. Like late medieval Europe, ninth century Scandinavia was also a time defined by conflict and the weapons used in battle such as the Viking Sword.



**Figure 2.19.** Viking sword from 9th century Scandinavia (Petersen, 2005).

## **2.3. Materials and Forging Technology**

### **2.3.1. Materials of Late Medieval Europe**

During the medieval era, iron, and eventually steel, would prove to be vital materials for the forging of weapons and tools. As nations would expand and battles would rage on, the need for iron would increase. Mining efforts across kingdoms would also expand as the demand increased. Different metal was traded across Europe as quality of metal directly correlated with the quality of goods, particularly with weapons where quality could mean the difference between life and death. While the Copper, Bronze, and Iron Ages had all long passed, the Middle Ages saw the development of different forging techniques based on these materials. These forging techniques would allow blacksmiths to craft desirable weapons and tools for numerous uses.

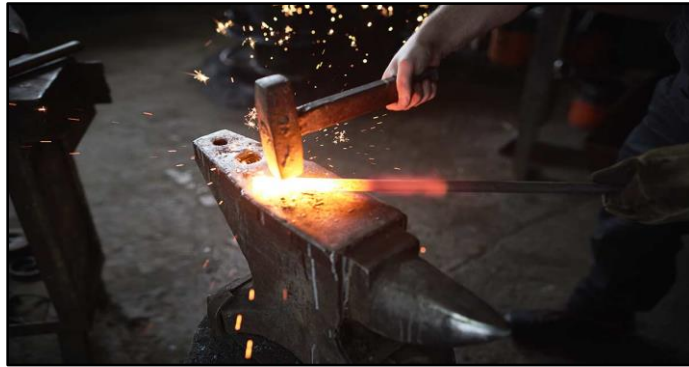
### **2.3.2. Historical European Forging Techniques**

When forging weapons, iron and steel would be the essential. While weapons developed prior to this time may have been made of copper, bronze, or iron with low carbon content, steel proved to be the quintessential material for forging both weapons and armor with desired material properties related to combat.

A blacksmith would be entrusted with working with whatever iron stock they were given and forming it into either weapons or tools. When turning the iron into steel, the blacksmith carburized the iron, or added carbon to the iron. Roughly 0.3 to 2.2 wt% carbon would be added, and anymore would make the steel too brittle to work into a weapon (cast iron). On the other hand, too little would make the steel soft and malleable, producing a rather ineffective weapon (Clements, 2006).

When carburizing the iron, it would have to be intensely heated and then hammered to imbue the properties into the stock material. While new material properties could be introduced because of the new heating methods, the logic of forging remained the same. Reaching a balance between the iron and carbon ratio would determine both flexibility and hardness of the resultant steel. Sometimes a blacksmith would use a core of softer steel and an outside layer of harder steel to make a weapon that was flexible but would not deform easily (Clements, 2006).

While every type of weapon, tool, and piece of armor that required forging would require different design requirements, they were all dependent on various material factors. A blacksmith's knowledge of the stock material used and the heats with which they treated the material would be reflected in the quality of their work. This was true for both the armors and weapons that would be forged throughout all Medieval Europe.



**Figure 2.20.** Illustration of a blacksmith hammering iron to shape (Moyer, 2018).

### 2.3.3. Forging of an Arming Sword

When it came to the creation of the arming sword in the late medieval period, it took a blacksmith with specific knowledge and years of experience forging weapons to create a quality sword. These specialized blacksmiths were known as swordsmiths. They had a much more sophisticated expertise of forging with steel and producing swords that were durable yet flexible. The main problem with forging of swords in late medieval Europe was that all knowledge had to be gained through the experience of trial and error (Clements, 2006).



**Figure 2.21.** Medieval swordsmiths (Clements, 2006).

The first step was selection of steel for the intended effect or function of the sword. For an arming sword, the steel had to have the qualities of deformation resistance yet still be flexible for hard impacts. Then the swordsmith would get to work shaping the blade using the typical medieval tools of hammer and tongs. Without modern forging tools, the working of the steel stock into a desired blade width, length, and thickness was an incredibly time-consuming process. Heating the steel into a moldable state without ruining it was also difficult, as it took much practice to learn the correct red-hot target color (no way to know exact temperatures).

After the long and grueling process of shaping the blade into its intended shape, the next step was heat treatment. In medieval Europe, this was only surface level knowledge that sword blades needed to be heat treated to become better and before seeing any combat. Swordsmiths knew nothing about the details of what heat treatment did to the metal, especially on the molecular level. They would first quench the blade by dunking it in water and then temper it by adding heat over time in the fire. Seeing there was no way to precisely measure time or temperature, heat treatment was more instinctual for swordsmiths (Clements, 2006).

The final phase of arming sword creation was grinding and sharpening. This involved putting the properly shaped and heat-treated blade on a grindstone which would file it down. This process would leave the blade with a shiny polished look and ready for the final adornments to be added. The grinding phase is also when a swordsmith would inscribe the blade with any signature touches or other recognizable features. For the sword to be complete a cross guard, hilt, and pommel were added too.

Understanding this process was widely undocumented and developed solely through individual practice, there was no common or correct way the arming sword was created. The process differed between every swordsmith who gathered their own lifelong experience and even between each individual arming sword made. Even so, swordsmiths of Medieval Europe were renowned in their craft and everything they did to create arming swords was truly artistic (Clements, 2006).

## **3. JAPANESE BACKGROUND**

### **3.1. History**

#### **3.1.1. Time period**

From 1192 to 1333 AD Japan was under the class system of Feudalism. This era was called the Kamakura period, as the Shogun Minamoto Yoritomo had a large influence on Japan. He had established the Kamakura Shogunate in the City of Kamakura. Yoritomo's actions defined the rise of the warrior class in Japanese culture, which was notably called the Samurai. This class would become an integral part of Japanese culture until the end of World War II and embodied the ideals of honor, bravery, loyalty, and military skill.

##### **3.1.1.A. Heian Period**

The Kamakura Period came directly after the period of time known as the Heian Period from 794-1185. This era was known as an era of relative peace time where culture and art flourished. However, during this time the Imperial Court began to lose power due to private estates, or clans, being exempt from taxation. Not only this, but individuals outside the Imperial family began to gain more political power by marrying their daughters off to Imperial heirs. The family that had the most control over the government through this method was the Fujiwara Clan. Another method that the Fujiwara Clan used to subvert the power of the Imperial Court came from the fact that many Imperial heirs took the throne as children. This meant that they were assigned a regent. The regent acted as both a caretaker and

advisor to the young emperor. However, they did not go away once the emperor came of age, allowing the regent to continue to influence the emperor until either the regent or emperor died or stepped down. This status quo lasted until 1087 when Emperor Shirakawa ceded his position of emperor to his son and became his son's regent rather than allowing a Fujiwara Clan member to step in.

During this time, private armies of samurai began to gain popularity among wealthy clans due to the rampant banditry in the nation. Two powerful clans with their armies of samurai slowly began to emerge: The Minamoto and the Taira. This, combined with the Fujiwara clan undergoing an internal power struggle, led to two small-scale wars in 1156 and 1160 between rival Fujiwara clan members as well as the Taira and the Minamoto. The Taira won these wars and dominated the government until 1180, when the Minamoto came back and waged war on the Taira in the Genpei War until 1185. The Minamoto won this war and the Taira leader was killed. This led to the Minamoto clan leader taking the position of Shogun and establishing the Kamakura Shogunate.

### 3.1.1.B. Kamakura Period

The Kamakura Period marked the beginning of the Shogunate becoming the dominant governing force in the nation rather than the Imperial Court. Despite the Shogun being underneath the emperor, the Shogun had control over the army while the emperor did not. This meant the Shogun had the real power in the government. The emperor was still seen as having a divine right to rule however, so many Shogun sought the endorsement of the emperor to lend legitimacy to their rule.



**Figure 3.1.** Painting of Minamoto no Yoritomo clan leader as shogun (Takanobu, 1179).

After Minamoto's death in 1199, his eldest son Yorie took the seat of Shogun. However, Minamoto's wife Hojo Masako and her father thought to take power for themselves and their family by subverting the Shogun the same way the Fujiwara did the Emperor. They established the position of Shogunate regent, giving the Hojo clan much power within the government. After the death of the Shogun Minamoto No Sanetomo, the current emperor, Emperor Go-Toba attempted a coup in 1221 to bring power back to the Imperial Court and away from the Shogunate and Hojo Clan. This coup ultimately failed, and Emperor Go-Toba was exiled from Japan to the Oki Islands where he remained for

the rest of his life. A relative peace in the nation persisted after this point. Due to this unusual lack of warfare in the nation, no clans were able to take land from other clans. Leading to a sort of stagnation for the most powerful families in the nation at the time. These families having a lot of time to themselves allowed them to gain a lot of military power due to the prominence of samurai and eventually led to the creation of daimyo, private military warlords that were not entirely under the control of the Shogunate. What ended the reign of the Kamakura shogunate and the Minamoto family at last was a mixture of internal problems with the regime and the invasions of the Mongols. After the Mongolian invasions, many samurai became disgruntled with the current Shogunate due to the lack of payment and sought to rebel. It was during this period of unrest that Emperor Go-Daigo attempted three different rebellions with the help of disgruntled warlords unhappy with the current Shogunate. While the first two were considered failures, the third one succeeded after a warlord by the name of Ashikaga Takauji betrayed the current Shogun and joined with Go-Daigo. This successful rebellion marked the end of the Kamakura Period and the beginning of the Muromachi Period, as well as an era of reconstruction known as the Kemmu Restoration.

### **3.1.1.C. Muromachi Period**

The Kemmu Restoration only lasted from 1333 to 1336, a meager three years. This was due to the emperor Go-Daigo refusing to grant Ashikaga Takauji the seat of Shogun. This angered Takauji and rebelled against the emperor, sending him into exile with Takauji and the Ashikaga clan taking the seat of Shogun. This period was notable for an uneasy peace and general lawlessness. The situation was not helped when Takauji escalated into violence with his brother and rival Tadayoshi and war broke out from 1350 to 1352. This war ended when Tadayoshi was poisoned. While there were no major wars until 1467, several daimyo, or warlords, gathered power and local influence. These daimyo had their own land and own personal army of samurai. While the Shogun was technically in charge and the daimyo supposedly being subservient to the Shogun, the daimyo had stronger control in whatever local region they resided in. Small conflicts between daimyo as well as the Shogun and daimyo perpetuated throughout this time. Especially in the case of taxes. Since the Shogun was not seen as a huge threat by the daimyo, many times they would simply refuse to pay the central government the taxes they were owed. This all came to a head in 1467 in the Onin War.

The Onin war was due to a succession crisis of the Shogun. There were two rightful heirs to the seat of Shogun, but two powerful clans at the time, the Hosokawa and the Yamana, disagreed on who it should be. These two clans gathered support from other smaller clans and full-scale war broke out. The winner was ultimately irrelevant despite a Shogun being put on the throne because they were effectively considered powerless in the face of several powerful daimyo and their armies of samurai. The capital, Kyoto, was also burned to the ground during the Onin war. With a powerless Shogun, the daimyo fought among each other for local power and influence. This period was known as the Sengoku Jidai, a 150 year long civil war between daimyo and their armies of samurai. During this time, the existing social and class structure collapsed completely. Anyone, including peasants, could rise in the class structure by securing land and power for themselves. The Muromachi Period finally ended in 1573 when Oda Nobunaga ended the Ashikaga Shogunate line, but the Sengoku Jidai still waged on, and would continue until Tokugawa Ieyasu took the position of Shogun and united the clans and daimyo.



## **3.1.2. Important Clans**

### **3.1.2.A. Taira and Minamoto Clans**

The Taira and Minamoto clans were both byproducts of what was known as “dynastic shedding”. Where emperors would have so many children that inheritance would be so split up to make it worthless. Therefore, the emperor would essentially form new families made of their children and leave them out of the royal family. These two families were the Taira and the Minamoto. These families developed a bitter rivalry as each family believed they had the rightful inheritance to the throne. Of course, due to the dynastic shedding, both clans were both right and wrong. While the two families were controlled by descendants of an Emperor, they were also completely left out of the system of inheritance. So, there was no possible way for either family to take the throne without warfare. This rivalry came to a head in the Hogen, Heiji, and Genpei Wars, where the conflict escalated into full on violence between the two clans. After Emperor Shirakawa subverted the Fujiwara clan’s control, he called on the Taira Clan to secure his power in the Imperial Court and crush the Fujiwara as well as the Minamoto who were helping the Fujiwara. At the end of all these wars, the Minamoto stood as the remaining clan and established themselves as the first Shogunate government.

### **3.1.2.B. Hojo Clan**

The Hojo Clan first rose to power by assisting the Minamoto family in the Genpei War. Hojo Tokimasa was a general that helped Minamoto Yoritomo. After the Minamoto clan won the Genpei war, Tokimasa was made warden of Kyoto and his daughter Hojo Masako married Yoritomo. When Yoritomo died, his son Yorie became Shogun and Tokimasa became regent to the Shogun, though Masako had more overall control. The reason why the regent and by extension the Hojo were so powerful was because the Shogun had their own constables and tax collectors in each province of Japan, and the one that controlled all of those was the Samurai military staff of the Shogun. And the leader of this staff was the regent of the Shogun. Therefore, the regent had control of the law and finances of basically the entire nation. And this office of regent was strategically passed down from Hojo member to Hojo member. What solidified the rule of the Hojo for years to come was the coup of Emperor Go-Toba. After the failed coup, a huge amount of land was taken and distributed among Hojo allies, friends, and family members. The Hojo would continue to rule with an iron fist until Emperor Go-Daigo staged a successful coup along with Ashikaga Takauji, overthrowing both the Kamakura Shogunate along with the Hojo Clan.

## **3.1.3. Wars/Conflicts**

### **3.1.3.A. Hogen, Heiji, and Genpei War**

The Hogen, Heiji, and Genpei wars were a series of wars fought between the Taira and Minamoto clans. The Hogen and Heiji wars were between the Fujiwara Clan and the current emperor. The conflicts started when the Emperor asked the Taira clan to defend his position of power from the Fujiwara clan. The position of Emperor was recently freed from Fujiwara clan control and the Emperor

wished to keep it that way. In response to this, the Fujiwara Clan took the Minamoto clan as allies against the Emperor and Taira clan. The Taira won these two wars, casting the Minamoto clan into hiding and ruining the Fujiwara's control over the government. The Taira dominated the government until 1180. When the Minamoto clan came back and declared war on the Taira again. This conflict was known as the Genpei War. This time however, the Minamoto clan won and the Taira was cast into obscurity. This victory secured the Minamoto clan's power and led directly to the establishment of the Kamakura Shogunate.

### **3.1.3.B Mongolian Invasions**

The Mongolian Invasions occurred during the rule of the Hojo Clan who at the time were controlling the Shogunate. After the Mongol's successful invasion and ransacking of China, the Mongols had a jumping off point to mount a sea invasion of Japan. Despite not being sea-faring people, the Mongols constructed boats and sent an emissary to the Japanese government demanding submission. The Shogun killed the emissary in response and war was declared. Despite managing to capture or destroy several garrisons off the coast of Kyushu, the invasion was quickly repelled. The Mongols were severely outnumbered by the Japanese, and the timing of invasion was poor as powerful storms were common in the area at the time of invasion. These two factors set the Mongols into a rout and the coming storm that the Mongols were afraid of killed many of the troops sent to Japan. The following year, the Mongols sent another emissary to Japan demanding submission which they responded to the same way. The Mongols then spent years preparing their second invasion of Japan. The invasion began in the year 1281. While the Mongols planned to make landfall long before typhoon season in Japan, the fleet was delayed and they finally landed in July, only a month before peak typhoon season. In this time the Japanese managed to mount a costly yet effective defense until another typhoon destroyed the Mongolian ships again and the invasion was repelled.

### **3.1.3.C. Sengoku Jidai**

The Sengoku Jidai was less of a war and more a series of conflicts between different daimyo across all of Japan. This time was also known as the Warring States Period and lasted 150 years. This era of war threw Japan into chaos, including any form of class structures. This was due to the Shogun being seen as powerless in the face of dozens of different daimyos, all of which had more local power in their respective provinces than the Shogun, as well as comparable armies. Because of this the daimyo could be thought of as kings of their own provinces, able to pass laws, tax citizens, and even conscript soldiers the way they see fit. As the class structures of Japan had all but collapsed during the Sengoku Jidai, several different factions ranging in size and power cropped up. Some individuals even thought to take this opportunity to become Samurai themselves and join in the fighting and secure wealth and power for themselves. The Samurai was still considered a high-class citizen at this point in time, and there were numerous pieces of art and literature that romanticized the Samurai and the Bushido code. Anyone could pick up a sword and join their daimyo to become a soldier, a samurai, or even the Shogun. The most famous example of this was Toyotomi Hideyoshi. Originally a peasant sandal bearer, he ended up as the successor to the daimyo Oda Nobunaga, who for a short time at least managed to unite Japan and act as Shogun.



**Figure 3.2.** Samurai on horseback (Kuniyoshi, 2011).

Larger groups emerged in the chaos as well. The most infamous being the warrior monks of the Ikko Ikki. The Ikko Ikki was a Buddhist sect of monks that appealed to the lowest caste of people for numerous reasons. The group did not require meditation, intellectual pursuits, or even celibacy. Rather they believed that they would be led into paradise by Amida the supreme Buddha when they died in battle. This group was a sort of rebellion against the feudalistic tendencies of the country at the time and wished to spread their religion across the country. This group managed to gain mass support and became a massive influence in Japanese politics at the time, even managing to successfully attack the capital of Kyoto. The Ikko Ikki was only stopped after Oda Nobunaga declared to completely eradicate the Ikko Ikki and sieged their fortress of Hongan-Ji for 11 years. The rise of a group like the Ikko Ikki showed just how non-existent the power structure of Japan was at the time of the Sengoku Jidai. A massive extremist religious movement became enough of a nuisance and influence in politics that it took the most powerful army in Japan years to take down, possibly even more so than some daimyo.

## **3.2. Arms and Armor of the Kamakura Period**

The weapons and armor used in the times of warfare in and around the Kamakura Period is incredibly varied, since the wealth of an individual affected what they could afford. There were some weapons used more than others but there was no standard arsenal for any soldier or samurai on the battlefield. Weapons also came and went depending on the times but a few managed to persist throughout.

### **3.2.1. Samurai**

The samurai emerged during the Heian Period as servants to local bureaucrats in several outer provinces. These servants were expected to be warriors and acted as private soldiers for different aristocrats. It was not until the Kamakura period where these samurai became more organized and powerful and became a new class of citizen. Samurai were a sort of aristocratic mercenaries that were loyal to a daimyo, or warlord. The samurai would swear allegiance to a lord and the lord would provide payment and protection to the samurai. With this, the samurai also had what is known as the bushido

code. The bushido code was a guideline for the samurai and stated that above all else the samurai would be loyal to their master over everything else. The typical samurai began as a heavily armored horse archer but as time went on and tactics changed, the samurai began to favor on the ground combat with swords, spears, and bows. As samurai were considered high-class citizens, they were able to afford higher quality gear than other soldiers. Samurai usually were equipped with plate armor, a yari spear, one or more swords, and a yumi bow. Tachi were used at first but gradually made way for swords like the uchigatana, katana, and the wakizashi.

### 3.2.2. Ashigaru

During the Onin War the samurai would employ the Ashigaru, which were the common foot soldiers. These men would be the serfs and peasants who worked the land owned by the samurai. The samurai would be accountable for recruiting and providing soldiers for the army. These common foot soldiers would be armed with the uchigatana and other common weapons like naginata, yari, yumi. The ashigaru were not paid but they were allowed any loot they could find after the battle was finished. This meant that after a few battles an ashigaru could become as well equipped as a samurai. Eventually the ashigaru became too tactically important to ignore, and they began to be better equipped, even being given guns when they were introduced to Japan.

### 3.2.3. Samurai Armor

There were many different types of armor during the time of the samurai that all varied in slightly different ways in terms of trading off mobility and protection, but the construction was kept relatively consistent. The armor was made of small interlocking plates tied together using rope, lace, or silk. Each individual piece of armor was put on one at a time. The cuirass protected the torso, while other pieces were put on the upper body to protect the arms and shoulders. This ended up leaving gaps in the armor, but this was intended to preserve the mobility of the samurai. At first ashigaru used whatever armor that they looted from the battlefield, ideally from dead samurai, however as ashigaru became more prevalent they were equipped with their own armor. The armor used had similar construction to a samurai's, but the armor used was lighter and less protective to reduce costs, as well as allow for greater mobility. Generally, armor got lighter the further from the Heian period as infantry combat became more prevalent over cavalry combat.



**Figure 3.3.** Samurai armor (Tokyo, 2020).

### 3.2.4. Weapons

#### 3.2.4.A. Uchigatana

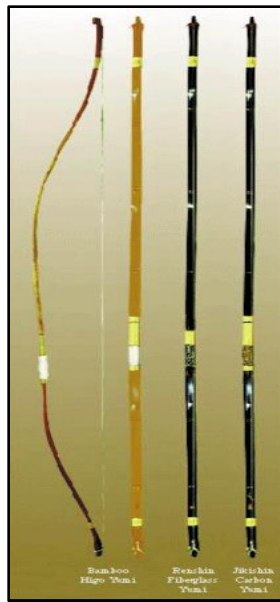
The uchigatana is the focus of the Japanese report. The modern version of the uchigatana has a construction that is close to the katana, however the uchigatana came first as a cheap, disposable weapon to be used by samurai and ashigaru. It only reached its mass popularity in the Muromachi Period. The uchigatana started its life in the samurai arsenal as a faster shorter version of the widely used Tachi. The uchigatana's size allowed it to be drawn quickly and even combine the drawing and striking motion into one. This technique was known as "Iaijutsu". The uchigatana lent itself well to this technique due to the way the blade was curved along with the scabbard. Blades were also oiled as a method of preservation while in the scabbard which also reduces any friction between the scabbard and the blade. This quickdraw capability solidified the sword's place as a close quarter, quickdraw weapon.



**Figure 3.4.** Uchigatana in sheath, uchigatana, and uchigatana blade (Draeger, 1973).

#### 3.2.4.B. Yumi

The bow, or the yumi, was typically made with bamboo and was by far the most popular weapon of the samurai. Despite blades such as the katana or the uchigatana being more famous, the yari was the most used and longest lasting of any of the weapons used by the samurai. Even when the arquebus rifle was introduced in Japan, the bow remained one of the most used and most effective weapons. This is for a few reasons. One being that a large volley of arrows in a group of enemies is devastating. Especially since samurai typically did not use shields. The bow also helped with sieges. Many Japanese castles were located on tall hills and difficult to assault. Having a samurai shoot up with incredible accuracy could turn the tide of the assault. Conversely, samurai shooting down at opponents from a high place could devastate an assaulting force. This popularity of the bow caused the creation of its own martial art called Kyudo. Combining a samurai's accuracy with the bow with the mobility that a horse allows turns a samurai into a serious threat.



**Figure 3.5.** Example of a yumi bow (DeProspero and Deprospero, 2012).

### 3.2.4.C. Tachi

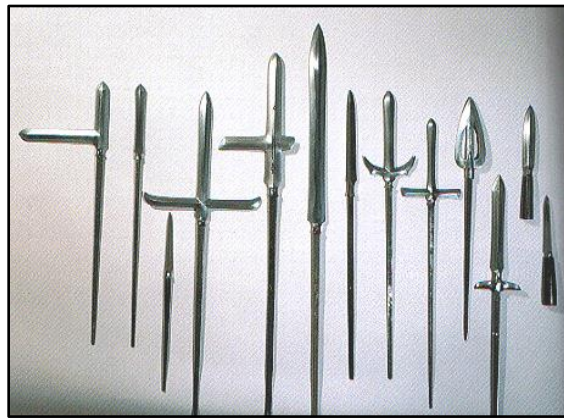
The tachi was the precursor to both the uchigatana and the katana. Like those two swords it featured a curved blade, but its length and weight were greater. This was to increase its lethality on horseback. After the invasions of the Mongols, the blade became even heavier and longer to further increase its effectiveness, as well as make it more effective against soldiers on horseback. The tachi remained the go to sword of the samurai until the rise and popularity of the uchigatana.



**Figure 3.6.** Tachi blade and mounting (Masatsune, 2020).

### 3.2.4.D. Yari

The yari was a version of the spear that emerged during the invasions of the Mongolians. Weapons like the yari were used by conscripts before the widespread presence of the samurai as a cheap way to arm peasants. However, once the samurai rose to prominence, the original spear was almost completely fizzled out of military tactics in favor of the bow and horse archery. The large pressure that the Mongols placed on Japanese infantry is what caused the readoption of the spear. Allowing units to pack together and stop cavalry in their tracks. Yari also could have many kinds of tips depending on how it was made and how it was planned to be used. Since the tips were also bladed, they could be used either by thrusting or by slashing.



**Figure 3.7.** Different yari heads (Anonymous, 2014).

### 3.2.4.E. Naginata

There was another polearm weapon used at the time known as the naginata. This was a glaive-like polearm with a curved blade rather than a point. While not as widely used as the yari for samurai, this polearm gained a lot of popularity with local warrior monks, such as the Ikko Ikki. This popularity likely stemmed from its adaptability, being longer than a sword gave it an advantage in close quarters while also helping deal with cavalry. While it has a disadvantage of being incredibly hard to use meaning it required a lot of training to use properly, this was not much of a problem for the warrior monks. As they would essentially dedicate a part of their lives to the study of martial arts.

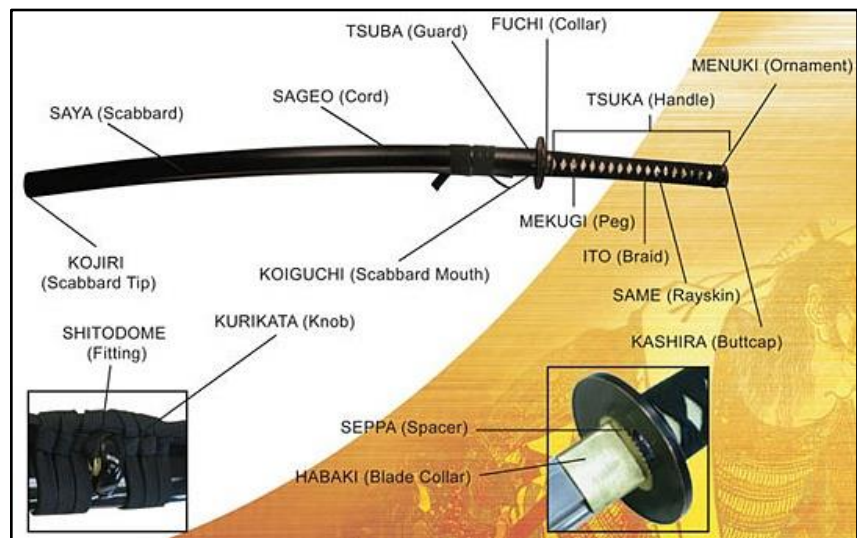


**Figure 3.8.** Example of a typical naginata (Armstrong, 2008).

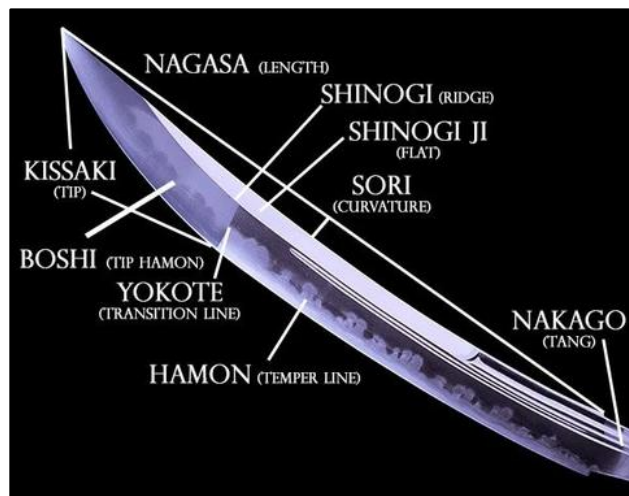
## 3.2.5. Uchigatana History

### 3.2.5.A. Design

The uchigatana is a curved blade with a long handle that could be used with one hand or two hands. The length of the blade varied but ranged from 60cm to no more than 70cm. The length of the handle was usually about 20cm long. The added length of the handle acted as a counterweight to the rest of the sword. The blade was single edged and worn in its scabbard with the blade side facing upwards. The more modern versions of the uchigatana also had what was known as a tsuba, which was a small circular handguard on the end of the sword handle. This tsuba was not really used practically but rather to tie the sword long with its scabbard to the belt of the soldier or samurai wielding it.



**Figure 3.9.** Various parts of a Japanese sword (Swords, 2020).



**Figure 3.10.** Japanese sword descriptions (SBG, 2020).

### 3.2.5.B. Location

The uchigatana was ubiquitous across all of Japan. Once created it spread to every soldier and samurai possible. The design of the uchigatana was never seen to be used outside of Japan. While China did import vast numbers of these swords, they were not seen using them to equip their armies. The current theory being that they imported the swords to keep them out of the hands of Japanese pirates.’

### 3.2.5.C. Applications

The uchigatana was originally made as a cheap and disposable sword in order to equip low ranking troops such as ashigaru. However, the curved blade of the sword as well as its comparatively shorter blade length when compared to a tachi lent itself well to a combined motion of draw and strike. Therefore, the uchigatana was a “quickdraw” weapon. Able to be switched to at a moment’s notice when the currently used weapon would not be ideal in the situation the samurai found themselves in.



### 3.2.5.D. Origins

The uchigatana was derived from an earlier blade known as the tachi. The tachi was a longer, heavier sword that was used mainly when the samurai were horseback warriors. The long heavy blade of the tachi lent itself well to cavalry charges, making it the ideal weapon when paired with the yumi bow. However, because of the need for additional soldiers beyond just samurai, the samurai hired ashigaru and equipped them with a smaller and very cheap version of the tachi. This sword was the bare minimum that an ashigaru would have. However as stated earlier, the smaller size of the uchigatana lent itself extraordinarily well to being drawn and striking in one swift motion. The construction of the tachi was very similar to the uchigatana in terms of forging techniques used and shape of the blade. Unfortunately, there are no surviving specimens of the early uchigatana so there are no images to be drawn from. However, given enough time, the uchigatana managed to become one of the most famous weapons of the samurai arsenal, comparable to the katana.

## 3.3. Forging Process

### 3.3.1. Materials of Kamakura Period

The type of metal used in crafting an uchigatana is a type of metal called tamahagane steel. It is steel that is made with a type of iron sand combined with coal in a clay pot. When heated, the iron is smelted out of the sand and combines with the carbon from the coal to produce steel alloys. However, this makes the steel only in small quantities when done by an individual smith, which is why the forging of Japanese swords is seen as so delicate. A lot of the steel could potentially be unusable due to an excessively high or excessively low carbon content. However, this is counteracted somewhat by a technique that Japanese smiths utilize to give the blades strength even with varying carbon content.



Figure 3.11. Raw tamahagane steel (Loulas, 2008).

### 3.3.2. Historical Japanese Forging Techniques

When the tamahagane steel was created, it was still not yet fit to be used in weapon making. Tamahagane has a high carbon content at 1-1.5 wt% carbon. If the steel were used in this way the blade forged would be very brittle. To prevent this, the sword smith would heat and hammer down the tamahagane into small sheets and quickly quench and cool them to make them brittle. These brittle

pieces were broken down into smaller pieces of varying carbon content. From here the smith could combine different pieces of steel to create a piece with a good ratio of carbon to iron to create a weapon or piece of armor that was not too brittle nor too soft.

### **3.3.3. Uchigatana**

The process used to create swords in particular is similar with all Japanese swords, including katana, uchigatana, and tachi. When the tamahagane was broken up into smaller pieces of varying carbon content, these pieces would be identified and “folded” on each other. The idea is that this folding would homogenize the steel to create an alloy that was neither too brittle nor too soft. The lower carbon content steel would form a sort of core of the blade. This lower carbon core was folded less times than the higher carbon steel. The higher carbon steel would form the “jacket” of the blade and be wrapped around the lower carbon core. Generally, the outer steel would be folded about ten times, but the smith would have to fold the steel as many times as needed to reach the desired homogeneity and crystal structure. Once the steel is prepared, it is hammered and elongated to the desired size and shape. As a final step to create the distinct blade shape, the back and sides of the sword are coated in a clay. This clay will keep the blade from cooling too quickly in the area it is covered. So, the uncovered edge becomes incredibly hard and brittle while the covered parts, as well as the low carbon core of the blade, give the blade flexibility. This also creates the distinct curve of the blade, as well as the hamon. The hamon being the cutoff point between the clay covered part of the blade and the hardened edge. All these techniques are what gave Japanese sword smithing a legendary status due to how delicate the procedure is to craft even a single blade. Each blade would be different due to metal carbon contents, the smith’s skill, and even time period (Roach, 2014).

## **4. MATERIALS SCIENCE CONSIDERATIONS**

### **4.1. Materials Selection**

After consulting with the blacksmith Josh, our group decided to use two types of steel when constructing our two replica swords. For the European Arming Sword, 1075 carbon steel was selected. For the uchigatana, a combination of two steels was recommended – the core of the sword would be made using 1045 steel, and the exterior would be made of 1075 carbon steel. These steels were chosen as their properties would be ideal for the design and fabrication of each respective sword.

#### **4.1.1. Compositions, Mechanical Properties, and Common Uses**

##### **4.1.1.A. 1075 Carbon Steel**

The 1075 carbon steel is defined as a high carbon steel with 0.75 wt% carbon. The 10 means that the steel is standard carbon steel and the 75 stands for the 0.75 wt% carbon content within the steel. This carbon percentage is crucial to determining the mechanical properties of the sword. Higher carbon

percentage will result in greater hardness of the steel, but also results in reduced ductility. Likewise, a lower carbon percentage results in the steel being more ductile, but softer. This balance is vital when creating weapons that need to be durable enough to sustain use without deforming, while also avoiding shattering due to the brittleness of the material.

The 1075 steel has a wide range of applications across numerous industries. Beyond blades, 1075 is used in springs, which also have multiple uses. Items such as clips, watch hands, brake discs, and lock picks are all reliant on 1075 for its specific material properties (AMS, 2020).

#### 4.1.1.B. 1045 Carbon Steel

Following a similar notation as the 1075 steel, 1045 carbon steel is a type of steel that has 0.45 wt% carbon content. This type of steel is considered medium carbon steel and has good machinability, as well as high strength and impact properties (AZoM, 2012).

The 1045 carbon steel has a wide variety of industrial applications. The material properties are desirable for applications requiring wear resistance and strength. This results in the steel being used for items such as gears, shafts, axles, studs, ratchets, and hydraulic clamps (AZoM, 2012).

### 4.1.2. Mechanical and Physical Properties of the Selected Steels

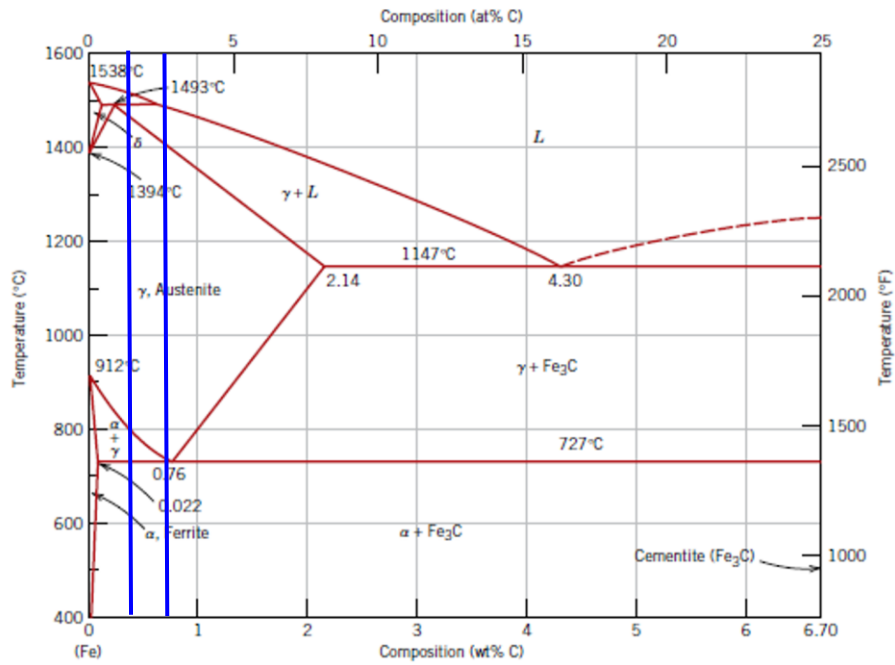
A comparison of the of the mechanical and physical properties of the two selected steels is given in Table 4.1.

**Table 4.1.** Mechanical and physical properties of the hot rolled steels (Material Properties Database, 2020)

Hot Rolled Steel	Tensile Strength (MPa)	Yield Strength (MPa)	Modulus of Elasticity (GPa)	Melting Point (°C)	Hardness (HB)
1075	650 - 880	350 - 550	190-210	1515	340 - 550
1045	570 - 700	300 - 450	180 - 210	1420	170 - 210

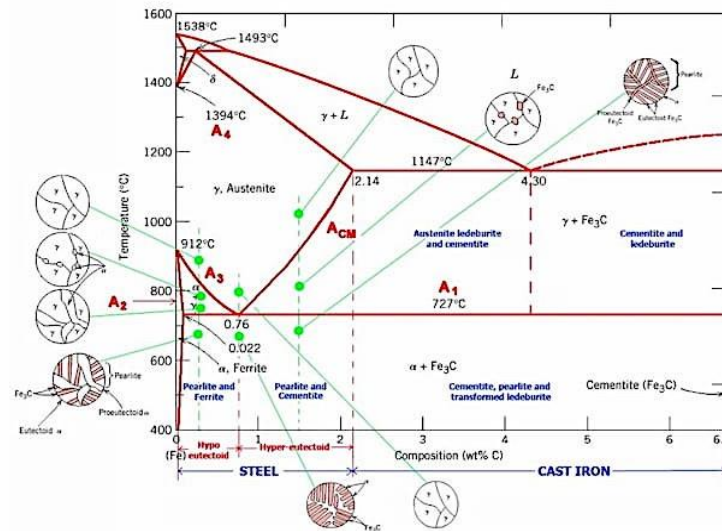
#### 4.1.3. Iron-Carbon (Fe-C) Phase Diagram

The Fe-C phase diagram is instrumental in gaining a better understanding of the vast complexity of the relationship between both temperature and the composition of the steel. Through various forging and heat-treating processes, the microstructure of each specific material will change. The way the microstructure develops is dependent on both temperature and material composition, and this relationship can be viewed through what is known as a phase diagram. In our case, the Fe-Fe<sub>3</sub>C phase diagram (up to 6.7 wt% C) was used, and the two steels of interest (1075 and 1045) have been marked on Figure 4.1 at their respective compositions. The phase diagram will provide the understanding of the microstructure formation under equilibrium (slow cooling) conditions in as-received (hot rolled) and forged conditions, after the replica sword is completed. The microstructure formation in non-equilibrium conditions will be discussed later in the context of the post-fabrication heat treatment.



**Figure 4.1.** Fe-Fe<sub>3</sub>C phase diagram with specific compositions for 1075 and 1045 steels (Evelyn, 2019).

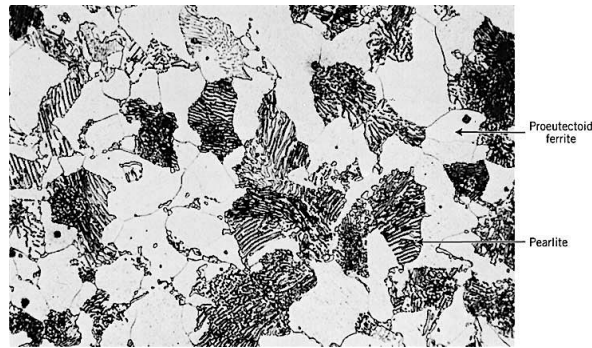
An important note to make on the phase diagram is the eutectoid composition at 0.76 wt% carbon weight percentage. A steel that has a weight percentage of less than 0.76 wt% is considered hypoeutectoid; thus, 1075 is a near-eutectoid steel, and 1045 is a hypoeutectoid alloy.



**Figure 4.2.** Fe-Fe<sub>3</sub>C phase diagram showing microstructures forming for different compositions (Velling, 2020).

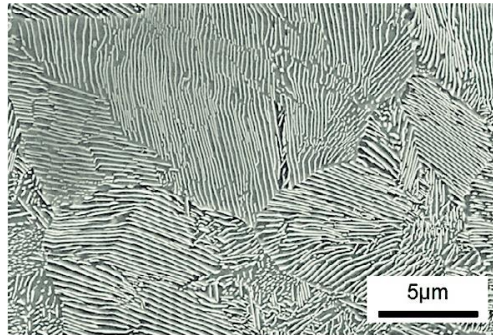
For a hypoeutectoid steel, using the 1045 steel as an example, when the material is cooled from the austenite, the solvus line will be crossed at 770°C. After this point, a solid solution called  $\alpha$ -ferrite will begin to form. Below the eutectoid temperature at 727°C, the remaining austenite that was not transformed into the proeutectoid  $\alpha$ -ferrite, will become pearlite, as shown in Figure 4.3. Pearlite is composed of eutectoid  $\alpha$ -ferrite and cementite lamellae. Ferrite is a ductile phase composed primarily of iron with a small amount of interstitial carbon atoms. Cementite ( $\text{Fe}_3\text{C}$ ) is a very hard and brittle

intermetallic compound. The strength of the steel is determined by the proportions of the two microstructural constituents, ferrite, and pearlite.



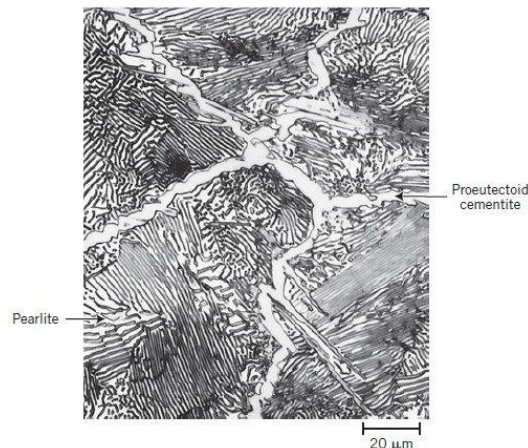
**Figure 4.3.** Hypoeutectoid steel microstructure with proeutectoid ferrite grains and pearlite (Foll, 2005).

Steels with carbon compositions at exactly / near 0.76 wt% are known as eutectoid / near-eutectoid alloys. When these steels are cooled from the austenite phase, the microstructures become pearlitic during the invariant transformation taking place at the eutectoid temperature of 727°C (no proeutectoid phase will be formed), Figure 4.4.



**Figure 4.4.** Eutectoid steel with a fully pearlitic microstructure (Hamada et al., 2011).

Hypereutectoid steel can be found when the carbon content of a steel is greater than 0.76 wt%. For example, using a steel of 1.2 wt% C, when this steel is heated to about 1300°C, the microstructure is comprised of austenite. When equilibrium cooling takes place, the proeutectoid cementite starts forming around 880°C, and the remaining austenite at the eutectic temperature will further transform into pearlite, as seen in Figure 4.5.



**Figure 4.5.** Hypereutectoid steel microstructure with proeutectoid cementite and pearlite (Dhaher, 2019).

#### 4.1.4. Predicted Microstructures of the Selected Steels (1075 and 1045)

Technically both steels are hypoeutectoid, however, the carbon content of the 1075 steel is nearly eutectoid, so the microstructure is expected to be mostly pearlite. Using the lever rule, we can calculate the expected weight fractions of ferrite and pearlite using the following calculations.

$$W\alpha(\text{total}) = (6.7 - 0.75)/(6.7 - 0.022) = .891 \times 100 = 89.1 \text{ wt\%}$$

$$WFe_3c = (0.75 - .022)/(6.7 - 0.022) = .109 \times 100 = 10.9 \text{ wt\%}$$

(a) Weight fractions of total ferrite and cementite phases for 1075 steel

$$W\alpha(\text{total}) = (6.7 - 0.45)/(6.7 - 0.022) = 0.936 \times 100 = 93.6 \text{ wt\%}$$

$$WFe_3c = (0.45 - .022)/(6.7 - 0.022) = 0.064 \times 100 = 6.4 \text{ wt\%}$$

(b) Weight fractions of total ferrite and cementite phases for 1045 steel

$$Wp = (0.75 - 0.022)/(0.76 - 0.022) = 0.986 \times 100 = 98.6 \text{ wt\%}$$

$$W\alpha(\text{proeutectoid}) = (0.76 - 0.75)/(0.76 - 0.022) = 0.013 \times 100 = 1.3 \text{ wt\%}$$

(c) Weight fractions of proeutectoid ferrite and pearlite for 1075 steel

$$Wp = (0.45 - 0.022)/(0.76 - 0.022) = 0.580 \times 100 = 58.0 \text{ wt\%}$$

$$W\alpha(\text{proeutectoid}) = (0.76 - 0.45)/(0.76 - 0.022) = 0.420 \times 100 = 42.0 \text{ wt\%}$$

(d) Weight fractions of proeutectoid ferrite and pearlite for 1045 steel

#### 4.1.5. Steel Sample Spectroscopy

After gaining access to a spectrometer, our group decided that it would be a good idea to analyze the actual composition of each steel to verify their composition. After running multiple measurements on each piece of steel, the average composition was obtained as shown in Table 4.2.

**Table 4.2.** Spectroscopy results for both steels (averages of 4 measurements)

wt%	1075 Steel	1045 Steel
<b>Carbon</b>	0.7%	0.48%
<b>Silicon</b>	0.252%	0.214%
<b>Manganese</b>	0.431%	0.75%
<b>Chromium</b>	0.279%	0.129%
<b>Nickel</b>	0.046%	0.170%
<b>Aluminum</b>	0.021%	0.040%
<b>Copper</b>	0.035%	0.304%
<b>Iron</b>	98.1%	97.7%

#### 4.1.6. Updated Microstructures of Both Steels (1075 and 1045)

$$W\alpha(\text{total}) = (6.7 - 0.7)/(6.7 - 0.022) = 0.898 \times 100 = 89.8 \text{ wt} \%$$

$$WFe_3c = (0.7 - 0.022)/(6.7 - 0.022) = 0.102 \times 100 = 10.2 \text{ wt} \%$$

(a) Weight fractions of total ferrite and cementite phases for 1075 steel

$$W\alpha(\text{total}) = (6.7 - 0.48)/(6.7 - 0.022) = 0.931 \times 100 = 93.1 \text{ wt} \%$$

$$WFe_3c = (0.48 - 0.022)/(6.7 - 0.022) = 0.069 \times 100 = 6.9 \text{ wt} \%$$

(b) Weight fractions of total ferrite and cementite phases for 1045 steel

$$Wp = (0.7 - 0.022)/(0.76 - 0.022) = 0.919 \times 100 = 91.9 \text{ wt} \%$$

$$W\alpha(\text{proeutectoid}) = (0.76 - 0.7)/(0.76 - 0.022) = 0.081 \times 100 = 8.1 \text{ wt} \%$$

(c) Weight fractions of proeutectoid ferrite and pearlite for 1075 steel

$$Wp = (0.48 - 0.022)/(0.76 - 0.022) = 0.621 \times 100 = 62.1 \text{ wt} \%$$

$$W\alpha(\text{proeutectoid}) = (0.76 - 0.48)/(0.76 - 0.022) = 0.379 \times 100 = 37.9 \text{ wt} \%$$

(d) Weight fractions of proeutectoid ferrite and pearlite for 1045 steel

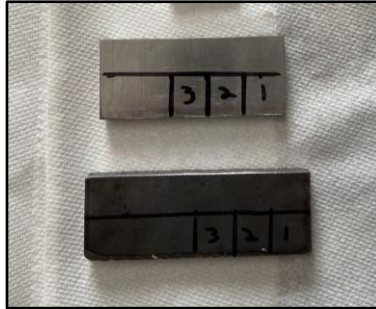
#### 4.1.7. Replica Carbon Steel Alloys

The 1075 carbon steel was ordered from New Jersey Steel Baron online. To prevent unnecessary hammering during sword fabrication, the optimal starting shape was decided to be a flat bar with a thickness of 0.6 centimeters. The length and width were 120 and 6 centimeters, respectively. According to the New Jersey Steel Baron product information, the 1075 flat bar comes cold rolled, pickled, and annealed. After the arming sword is fully forged from the 1075, a customized heat treatment will be applied. The first is normalization where the grain is refined and internal stresses on the blade are relieved. Normalizing is the process of high temperature austenitizing a metal alloy and is followed by air cooling. This is typically performed to remove any segregation in the microstructure and homogenize the overall iron-carbon alloy (Zimmerman, 2020). Since our arming sword is a blade, three normalization cycles at 871, 816, and 774°C for 5, 5, and 10 minutes, respectively, should work well. The next step would be the hardening process for the durability and toughness expected from an arming sword. For 1075, it is suggested to heat the blade to the austenitizing temperature of 816°C, quench it in an oil medium, and then hold it to soak for a short duration of time. The 1075 arming sword heat treatment process would finally be finished by tempering after it is hardened. As previously mentioned, this will temper the martensite (formed upon quenching in the previous step) to prevent the blade from becoming too brittle. For a desired hardness rating to be later determined, the blade will be tempered once at 204°C for two hours (had the specimen been thicker this process would have been done twice).

The 1045 carbon steel was ordered for the team by a heat treatment plant near Worcester, and was also received cold rolled, pickled, and annealed. It came in the form of a flat bar with the length, width, and thickness being 76, 4, and 0.6 centimeters, respectively. This bar of 1045 will serve as the core for the uchigatana, and therefore will be heat treated as 1045 would with a slight caveat. The heat treatment will follow a similar protocol as a steel with the combined carbon content of the 1045 and 1075 steels.

## 4.2. Microstructure Analysis Process

In order for the metal pieces to fit inside the machine, that would mount the specimens, we needed to cut individual pieces into cubes. After getting all of the pieces of metal, we took the pieces to the WPI Machine Shop to cut them. The 1075 was cut into small cubes using a vertical bandsaw. The 1045 was plasma cut, which made it very difficult to cut on a bandsaw. Thus, we had to use a hacksaw instead to cut the pieces of 1045. The cuts were made to expose the XY, XZ, and YZ planes to characterize the microstructure in all three orientations.



**Figure 4.6.** 1075 and 1045 steel marked for cuts.



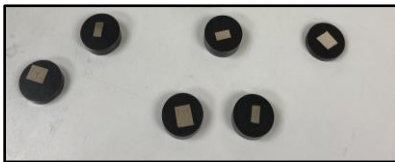
**Figure 4.7.** Vertical bandsaw.

There were six samples of metal in total, three for each alloy, which we would have to mount. Our first step in analyzing the samples was to mount it in a mounting press for metallographic preparation. This step required that we place the individual specimen with the side we wanted to analyze face down, then pour mounting powder in the machine. After this step, we closed the machine and ran it at high temperature so that the mounting powder would be melted and compressed around the specimen, creating a hockey puck with the specimen centrally located. We would repeat this step with all six specimens, then proceed to grind and polish the specimens with sandpaper.





**Figure 4.8.** Mounting the steel specimens.



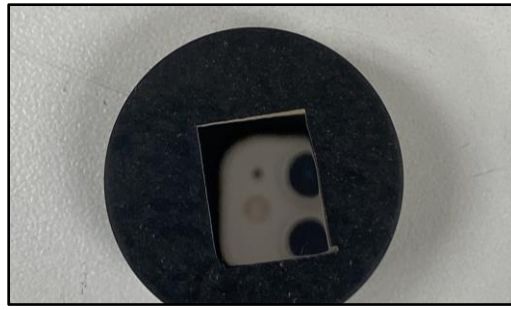
**Figure 4.9.** The six specimens mounted in the “pucks”.

The machine that we used for grinding allowed us to grind all six specimens at once. After placing the pucks in the machine, we began by grinding it with 120 grit sandpaper. We repeated this process with 320, 600, and 1000 grit sandpaper. When using the 1000 grit sandpaper, directly after removing the samples, we washed the specimen faces with acetone and used a blow dryer to dry them. At this point the surfaces were visibly smoother, and we then moved on to the polishing steps.



**Figure 4.10.** Grinding the specimens using different grit sandpaper.

For polishing, we used a 3-micron diamond solution to further create smoother surfaces of the metal specimens. Before running the machine, we applied the 3-micron diamond suspension fluid to the surface of the film. The machine was run for 5 minutes with this film, occasionally applying more suspension fluid. During the last 20 seconds of the machine running, water was applied to the film to remove any residual suspension fluid to avoid crystallization on the surface of the metal specimen. Like the grinding process, acetone was sprayed on the surface, and then dried with a blow dryer. The mirror polished surfaces when then etched in the final step.



**Figure 4.11.** A mirror polished specimen, demonstrating the reflectiveness of the surface.

During the etching process, we took one specimen at a time and submerged the face in sodium metabisulfite for a period of 5-10 seconds. After being submerged, the surface was sprayed off with acetone, then distilled water, and then it was dried. After being dried the specimen was examined under a microscope to determine whether the etching was sufficient or not. If it was not sufficient, the specimen was etched for another 5 seconds, washed, dried, and then reexamined. This process was done for all six specimens. Once etched appropriately, pictures were taken to reveal the microstructures of both materials for each of the three planes.

Using the microscope, each specimen was examined at different objective lengths ranging from 5x to 100x. This value would be multiplied by 10 to achieve the magnification that was used. Most of the images were taken at either 500x or 1000x magnifications. When each picture was taken, they were labeled appropriately with the type of metal, the specific plane, and the magnification of the image. The microstructures for both steels are shown in Figures 4.12 and 4.13.

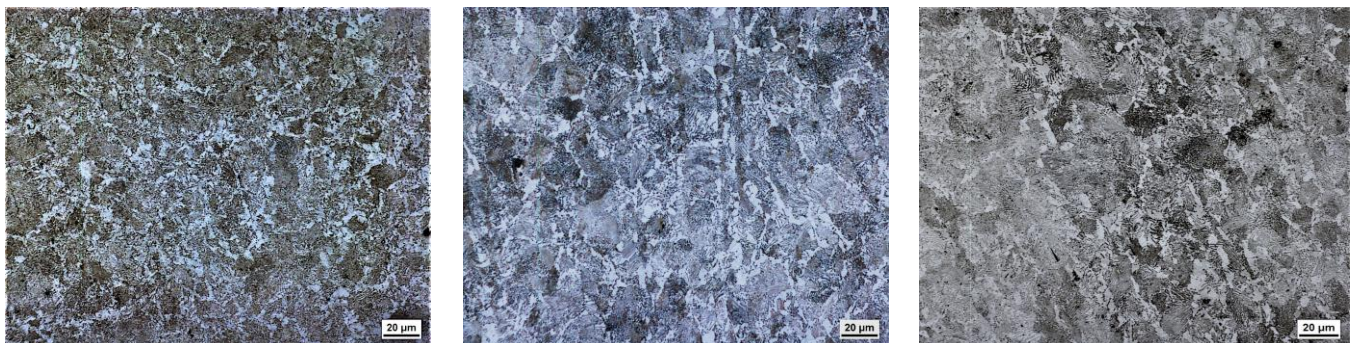


(a) XY plane

(b) XZ plane

(c) YZ plane

**Figure 4.12.** Microstructure (pearlite) of 1075 steel in three planes (500x magnification).



(a) XY plane

(b) XZ plane

(c) YZ plane

**Figure 4.13.** Microstructure (ferrite and pearlite) of 1045 steel in three planes (500x magnification).

## **4.3. Heat Treatment and Effects of Cooling Rates**

Heat treatment is the process of improving mechanical properties through the general steps of heating, holding, and cooling. The specific heat treatment type and conditions both vary between metals and their intended applications. This is a vital stage of almost all metal manufacturing processes as it is estimated that heat treatment adds around \$15 billion to the value of metal products each year. That added value comes from the improvement of metal properties such as durability, formability, strength, etc. (HTS, 2020).

### **4.3.1. Types of Heat Treatment**

There are many types of heat treatments, and it is important to understand the differences between them in order to decide the final heat treatment for the replica swords. Some of the most common methods are annealing, carburizing, hardening, and tempering.

Annealing is the staged process of heat treating a metal and making it more resistant to cracks/breaks with enhanced ductility. This involves heating the metal to a specific temperature and then cooling it at a controlled rate. Annealing increases both toughness and ductility of the metal for easier machining. The first step is to heat the metal to a temperature that relieves the stress in the crystal lattice structure. Then the heat is raised to just below the overall melting temperature of the metal. This step of annealing allows for the recrystallization of the internal structures, but without the stresses present in its initial condition. Then finally, to finish the annealing process, the metal is cooled from this maximum temperature at a controlled rate. This entire process is most seen in metal alloys that require high ductility or will be machined (Fraser, 2020).

Carburizing is the process of diffusing carbon onto the surface of a metal to increase its overall surface hardness. This results in a metal product that has a resilient surface and soft core that was maintained from its original state. The process of carburizing involves heating an iron or steel simultaneously with a carbon host material that applies a carbon content onto the surface area of the product. After it experiences this diffusion process, the iron or steel is then quenched, which causes the outer surface to become hard while leaving the original internal metal soft. This is often applied to low carbon alloy steels or low carbon steels. The product of carburizing is a metal that has a hard and resistant surface able to withstand wear and fatigue (Cullman, 2020).

Hardening is the form of heat treatment where a metal is heated higher than its transformation temperature then quickly cooled. The level of hardening is controlled by the time it is held over the temperature threshold. The cooling can either be done by quenching in water/oil or left in the open air. Overall, this process hardens the entirety of the metal improving its mechanical properties. It is also often performed to increase the durability of a product as the hardness will make it tougher and more resistant to material wear. Hardening is almost always a step of heat treating, usually followed by tempering in a larger series of methods (Parrish, 2012).

Tempering is the accompanying heat treatment process to hardening because it is used to counteract any negative effects that were not intended for the final product. As is the case with hardening, it could often leave the metal with too much hardness that it becomes brittle (lacks toughness). Tempering relieves the brittleness and stress while keeping the metal at its desired hardness. This process involves reheating the metal after it is quenched, or air cooled, to a much lower temperature. The exact temperature and time it is held there depend on the desired hardness range of the product. Some metals can also be tempered with a protective gas that prevents surface oxidation if that is a possible risk. As a result, utilizing both hardening and tempering allows for a wide range of final hardness and toughness combinations in heat treating metals. (Bodycote, 2019).

These are just a few of the most common heat treatment methods. There are numerous methods that can be tailored exactly to different metal products according to their final purpose. However, this brief overview emphasizes just how important heat treatment is to the creation of long lasting and quality metal products.

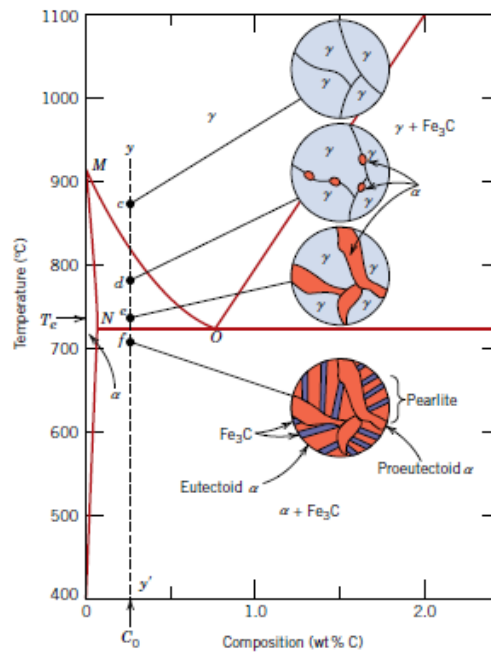
### **4.3.2. Phase Transformations**

Cooling rates have a large influence on the microstructure of the metal alloys during the heat-treatment process. This is important as the properties of such alloys can change drastically depending on their microstructure. A comparison of the equilibrium and non-equilibrium cooling will be discussed next.

#### **4.3.2.A. Equilibrium Cooling**

Equilibrium cooling is the slow-paced cooling of a metal alloy like Fe-C. This slow cooling emulates equilibrium conditions as close as possible for the alloy to have an extremely slow transformation process. As discussed earlier, Figure 4.14, shows the microstructure formation for a low carbon steel that experiences slow equilibrium cooling, resulting in proeutectoid  $\alpha$ -ferrite and pearlite.

At point c, around the temperature of 875°C, the microstructure is composed of  $\gamma$  phase grains (austenite). As the alloy cools to point d, around 775°C, both  $\alpha$  and  $\gamma$  phases exist in the microstructure at once. The  $\alpha$ -ferrite forms in small patches along the original  $\gamma$ -grain boundaries. As the alloy cools through the  $\alpha + \gamma$  phase area, the composition of the ferrite phase is altered according to the temperature and becomes higher in carbon. From point d to e, as the alloys cools even further, the fraction of  $\alpha$  phase is increased as the  $\alpha$  phase become much larger than the initial ones formed. Finally, the temperature is lowered to point f which is just below the eutectoid. This is where all of the  $\gamma$  phase present at point e (eutectoid composition) transforms into pearlite. The proeutectoid  $\alpha$ -ferrite phase is barely affected leaving it with the same amount and structure present at point e, even after crossing the eutectoid temperature (Callister, 2014).

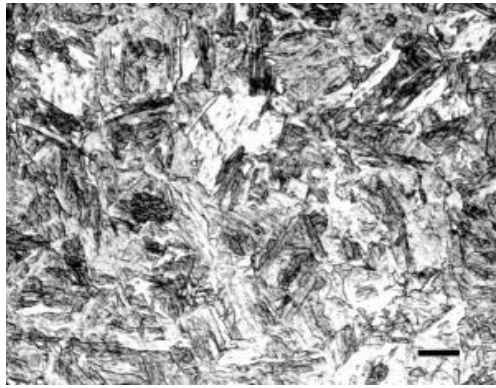


**Figure 4.14.** Fe-C phase diagram showing the microstructure evolution for a hypoeutectoid steel (Callister, 2014).

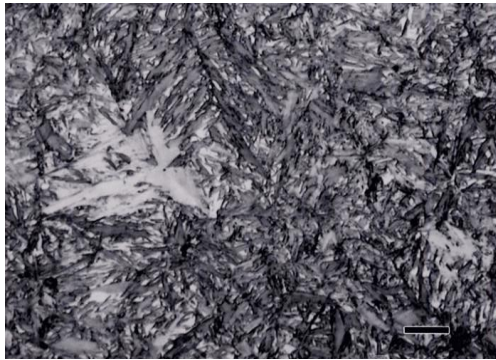
### 4.3.2.B. Non-Equilibrium Cooling

Non-equilibrium cooling is the fast cooling of a metal alloy. In contrast to equilibrium, the metal cools too quickly for the microstructure to transform according to the ideal conditions. When planning for the heat treatment and cooling of our own Fe-C alloys, it is important to understand the different phase transformations that could occur and the properties of the resulting material with its microstructure. Austenite is the solid solution of iron-carbon that exists in the  $\gamma$  phase field. This is usually where iron-carbon alloys are heated prior to cooling, which is part of the overall process called austenitization. Pearlite is a lamellar microstructure composed of ferrite and cementite. The amount of these two phases determines the properties of the resulting fine or coarse pearlite. Fine pearlite is stronger while coarse is more ductile. In fine pearlite, the larger amount of cementite allows the overall alloy to be strong and rigid as it prevents the softer ferrite from deforming. The inverse is true in coarse pearlite due to the opposite balance of ferrite and cementite (Callister, 2014).

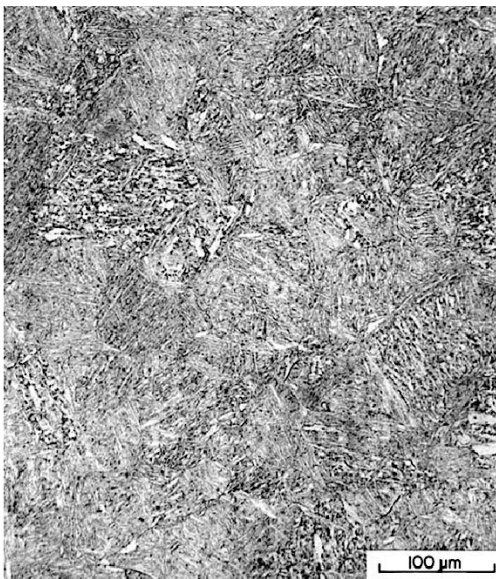
Another iron-carbon microstructure that can form is martensite. Martensite is formed when the steel is cooled from austenite at a very fast rate, generally through quenching. This constituent is very hard due to the carbon which becomes trapped in the solid solution. Martensite can exist in two forms, known as lath martensite, which develops in low carbon steels, and plate martensite which develops in high carbon steels. Lath martensite produces higher ductility and toughness, but lower strength, whereas plate martensite has much higher strength, but tends to be more brittle and lack ductility. In order to rectify this brittleness, the material can be tempered, resulting in a microstructure of tempered martensite. This allows the carbon atoms to move out of the spaces between the iron atoms in the martensite to form iron carbide particles. The strain within the martensite is relieved, which results in an improvement in the steel toughness, at the expense of reduced strength. The amount of required tempering varies across different steel applications.



**Figure 4.15.** Lath martensite in 1524 alloy steel (Vander Voort, 2014).

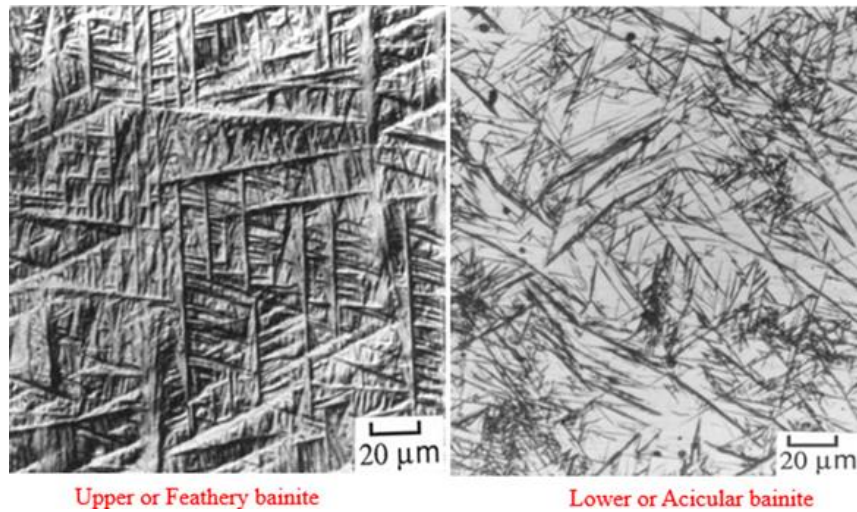


**Figure 4.16.** Plate martensite with small amounts of retained austenite in 1095 steel (Vander Voort, 2014).



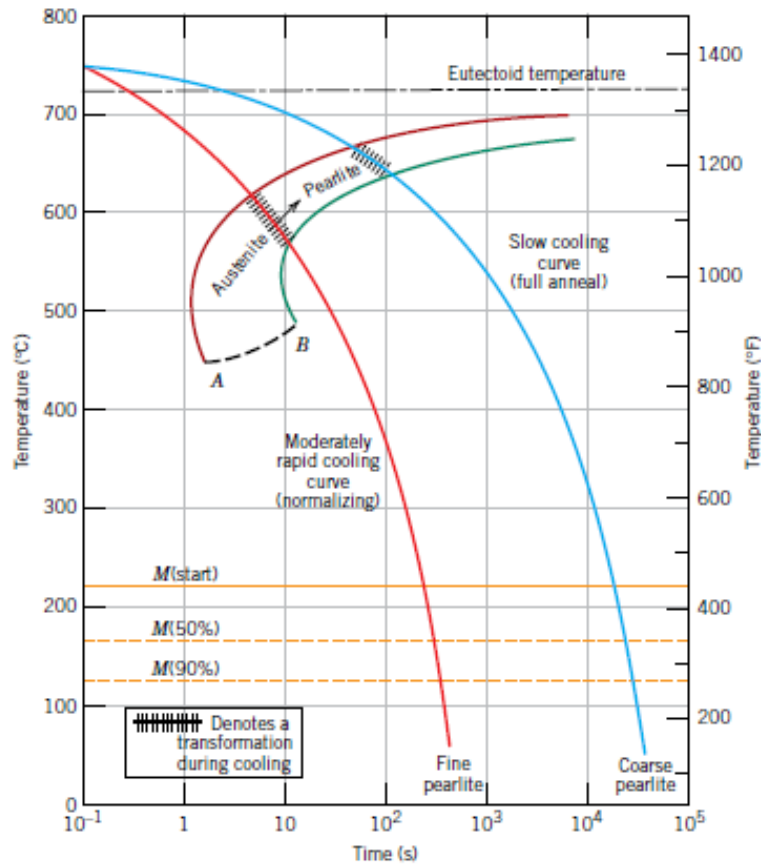
**Figure 4.17.** Tempered martensite in a HT9 steel (Klueh and Nelson, 2007).

On the other hand, when the steel is cooled quickly from austenite, but not fast enough to become martensite, it becomes bainite. This form of microstructure has a desirable combination of strength and ductility. Bainite comes in two primary forms, upper and lower bainite. Upper bainite is usually formed at higher temperatures (400-550°C), compared to lower bainite which is formed at lower temperatures, very close to the martensitic formation temperatures. Lower bainite can sometimes be compared to a lightly tempered martensite in terms of structure.



**Figure 4.18.** Direct comparison between upper and lower bainite in carbon steel (Rohit, 2020).

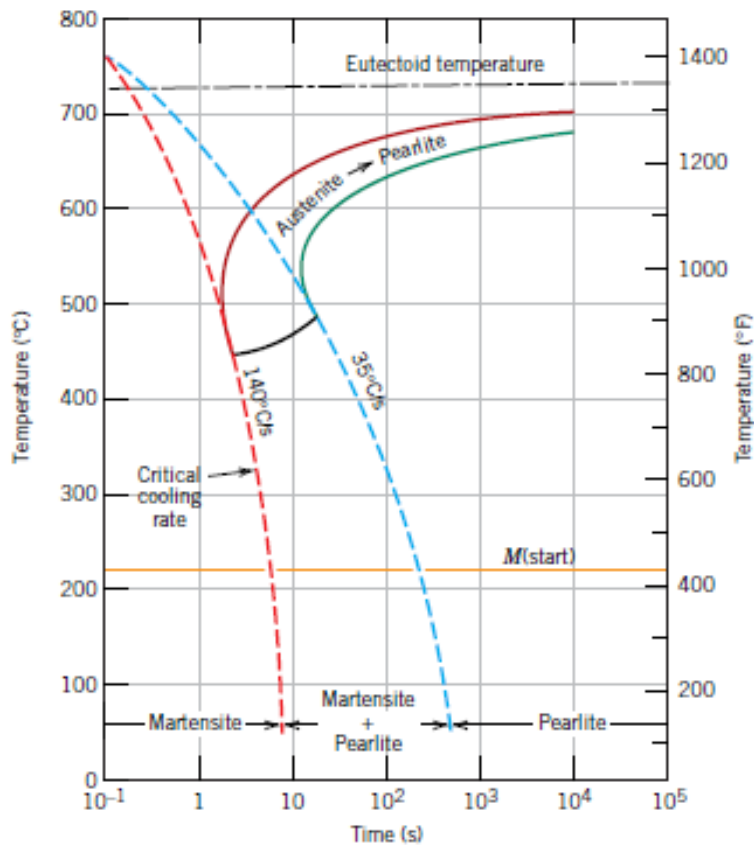
The heat treatment of most carbon steels involves continuous cooling of the metal until it reaches room temperature. The effects of these cooling rates can be visualized with the help of continuous-cooling transformation (CCT) diagrams. In Figure 4.19, two cooling curves are shown, one for relatively fast cooling and the other for slow cooling.



**Figure 4.19.** Eutectoid iron-carbon alloy CCT diagram (Calister, 2014).

As seen in Figure 4.19, the resulting microstructure is coarse pearlite for slow cooling and fine pearlite for faster cooling. This transformation begins when the curve intersects with the reaction curve

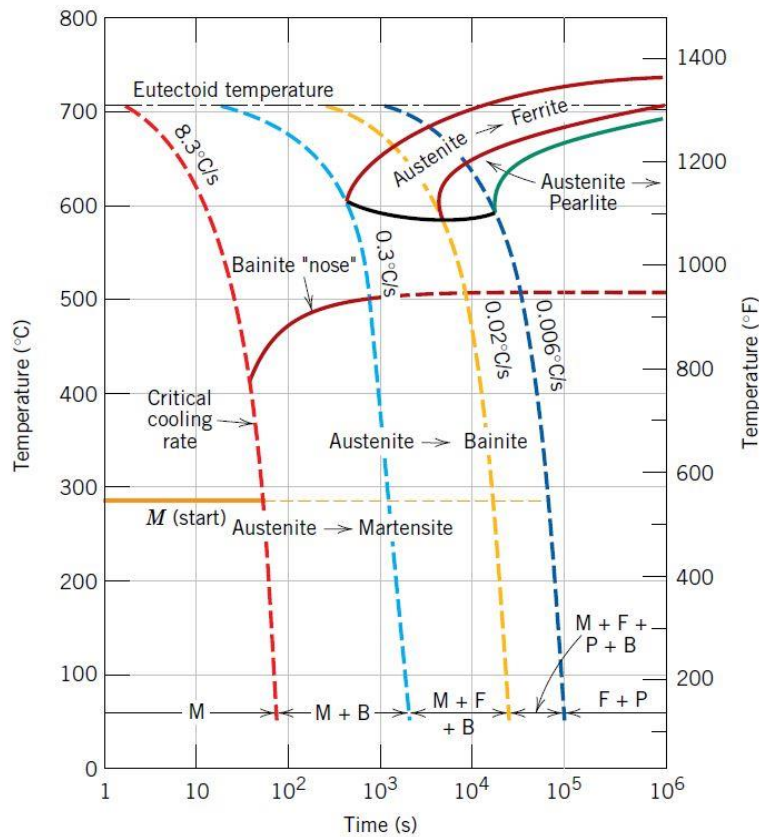
(red line) and concludes across the end (green line). At this point, after it has crossed the reaction curve, any remaining austenite starts to turn into martensite when it reaches the M (start) line. It is important to note that no bainite will form when a carbon steel is continuously cooled to room temperature as seen in the diagram. Since the austenite is turned into pearlite first on this cooling curve, by the time it reaches the bainite transformation area there is no austenite left. This is explained by the reaction curve being stopped early by the line AB. There is also a critical quenching rate for steel alloys when cooled continuously. This rate is the minimum rate the metal must be cooled for the entire microstructure to be composed of martensite. This critical cooling rate and relationship to the resulting microstructure can be seen on the CCT diagram in Figure 4.20.



**Figure 4.20.** Final microstructure transformations on CCT diagram (Calister, 2014).

The critical cooling rate that allows a quenched steel alloy to become 100% martensite is anything that is greater than 140°C/s. If the cooling rate intersects with only the middle part of the reaction curve, then the resulting microstructure will be a blend of martensite and pearlite. Lastly, any cooling rate lower than 35°C/s produces a microstructure of all pearlite, which was explained through the first CCT diagram (Figure 4.19). This is relevant for our replica construction as the intended cooling rate should be high enough to produce an entirely martensitic structure (falling in the critical cooling rate zone). Seen on the final CCT diagram in Figure 4.21 are the cooling curves and the resultant microstructures for a 4340 alloy steel.





**Figure 4.21.** CCT diagram for 4340 steel with cooling rates and corresponding microstructures (Calister, 2014).

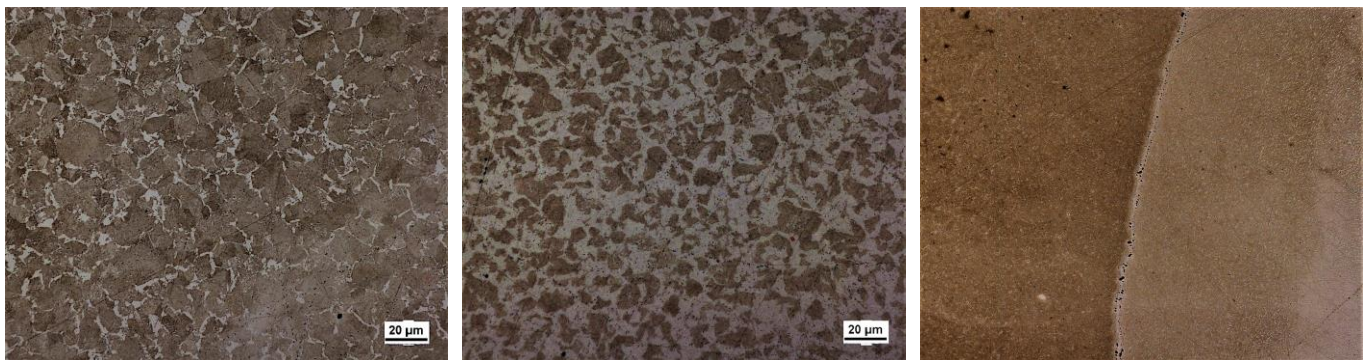
In this diagram it is important to recognize the “Bainite nose” as this explains the presence of bainite in the alloy's final microstructure. This directly relates to our heat treatment as we had the option of cooling the carbon steel alloys in either water or Park’s 50 quenching oil. The goal of our heat treatment and hardening quench was to achieve a fully martensitic microstructure that provided our sword with the desired hardness. Fortunately, both quenching media would cool the steels at a rate suitable to fall in the martensite zone and miss the “Bainite nose”. The reason to choose Park’s 50 oil over water is that it maintains a high rate of cooling, but is much less harsh on the steel and provides a greater chance of success (no cracking, low distortion, etc.).

### 4.3.3. Worked/Heat Treated Microstructure Analysis

When both swords were worked, they would undergo combinations of heating and cooling cycles. We decided to examine the microstructure both after the steel had been worked in the forge, and after the steel had been heat treated. Unfortunately, both replicas were too large to fit into the kiln where the heat treatment would be performed, so we decided to use a smaller piece of similarly worked material from each sword material and heat treat those pieces. The pieces were both heated above the eutectoid temperature so that all the steel transformed to austenite. The steel would then turn into fully martensite upon getting quenched in Park’s 50 oil. This transformation would result in mechanical properties that would be desirable for a sword. Similar to the unworked metal, we then examined the pieces using an optical microscope to determine the final microstructures of the materials.

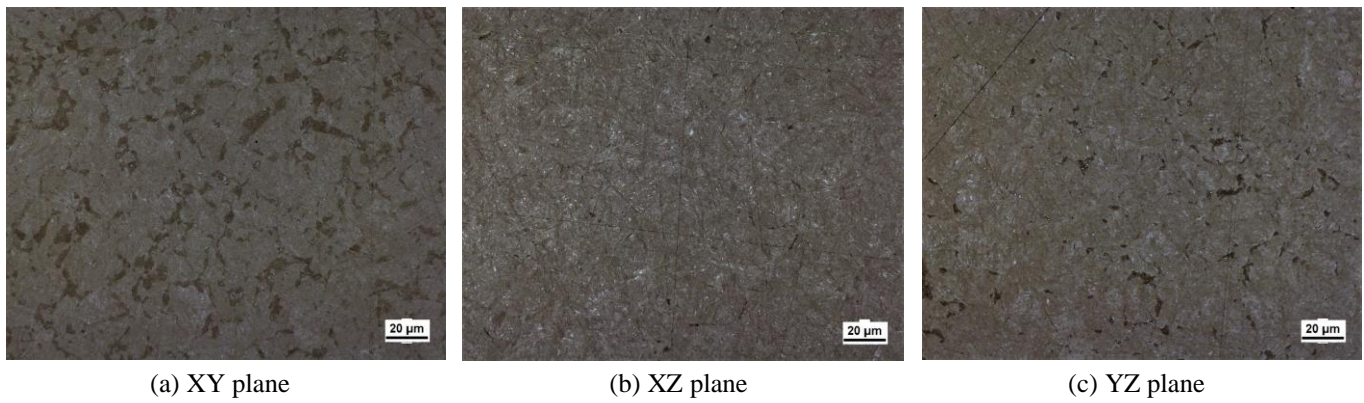


(a) XY plane (b) XZ plane (c) YZ plane  
**Figure 4.22.** Microstructure of forged 1075 steel in three planes (500x magnification).



(a) XZ plane (b) YZ plane (c) Weld Boundary (5x magnification)  
**Figure 4.23.** Microstructure of forged 1045-1075 combined steel (500x magnification).

After observing the microstructure of the fully 1075 steel samples (in all three orientations), Figure 4.22, it was clear that the material still retained a pearlitic microstructure, which makes sense based on the process followed for working the metal. Before the steel was worked, it was necessary that it was placed in a forge and heated to a high temperature. The temperature of the forge brought the metal within the austenite phase. Following the working of the material, it would be air cooled slowly. This slow cooling combined with its near-eutectoid composition provides an explanation for the presence of pearlite within the sample. In a similar manner to the 1075 steel, the combination of 1045-1075 steel had to be heated up and hammered to shape the metal. This metal was forge-welded together in order to join the two pieces of 1045 and one piece of 1075 into one continuous bar (in a “sandwich” arrangement). The boundary between the two steels can be observed in Figure 4.23(c). With a lower carbon content than the 1075 steel, the presence of ferrite (as well as pearlite) in the forge-welded 1045-1075 steel is reasonable. After forging, we would then move onto performing the final heat treatment.



**Figure 4.24.** Heat treated 1075 steel in three planes (500x magnification).



**Figure 4.25.** Heat treated 1045-1075 combination in two planes (500x magnification).

Both bars were heat treated with the exact same heat cycle and quenching medium per recommendation of the blacksmith. The first step of heat treating is to normalize the steel. This requires 3 cycles of heating to a specific temperature for a set time interval to relieve the stress before it is hardened. The cycles are as follows: 871°C for 5 minutes, 816°C for 5 minutes, and 774°C for 10 minutes. Then the samples will undergo the hardening process. This involves heating the bars to a specific austenitizing temperature and then quenching them in Park’s 50 quenching oil. The austenitizing temperature that was used is 816°C, followed by soaking the bars for 30 seconds in the quenching oil while keeping them in motion to achieve uniform cooling and avoid warping. Then, as the final step, the hardened steel was tempered at 204°C for 2 hours.

The resulting microstructures can be seen in Figures 4.24 and 4.25 and demonstrate the predicted outcomes for a hot steel being quenched in oil. The samples are composed of tempered martensite, with a presence of small carbides. The heat treatment resulted in the strengthening of the steels, also with good ductility, which was the desired outcome. We additionally did hardness testing (Rockwell hardness) on the heat treated 1075 sample to see if the heat treatment produced our desired results. Our heat treatment was similar to that recommended by New Jersey Steel Baron (NJSB), which consisted of normalizing at 898, 815, 732°C for 10 minutes each, austenitizing at 801°C followed by quenching, and double tempering at 204°C for 2 hours each. The measured hardness of our heat treated material was approximately 55 HRC, comparable to NJSB’s intended post-heat treatment hardness. This means that our process was a success, and if we had performed the same heat treatment on our swords it would have provided the desired combination of hardness and ductility for medieval combat.

# 5. FORGING TECHNIQUES

## 5.1. Traditional Methods

Many modern industrial metal fabrication practices still use medieval and ancient blacksmithing and forging techniques today. Forging metal property manipulation and the use of alloy material all come from pre-industrial forging and blacksmithing techniques. While the technological resources and capabilities of metal fabrication and manipulation have experienced great leaps forward, there are still basic elemental practices that the industry owes its prosperity to.

Metal manipulation is believed to be discovered during the bronze age. Bronze Age metal fabricators and traders were known to have mined and smelted lead and copper, alloying with tin, arsenic, and other metals to create bronze. This alloy gives the bronze increased strength and value. Lead was usually melted in campfires. It was used as mortar, a pliable metal for water containment and for piping in ancient Greece and Rome. Copper came next, and with it the kiln, because of the temperatures required to melt the metal.

### 5.1.1. Traditional European Forging

Swords were the quintessential piece of weaponry in Europe during the Medieval Period and as such, they would be produced all over the region during this time. A good sword would be produced so that it could hold an edge, retain its shape, but still be flexible enough to avoid shattering. During the Medieval period, these swords were forged almost exclusively out of steel, a combination of iron and carbon. A sword was considered no better than the steel from which it was forged, so the selection process for determining what steel would be used to forge a sword was crucial.

Some bladesmiths would rely on trained smelting professionals to reforge ingots which they could then shape into the blade of their liking, while others would smelt the raw iron ore themselves. Measuring the carbon content in the steel which they produced was virtually impossible in Medieval times so the proper carbon content of the steel would have to be determined by someone who had boundless experience with the process (Clements, 2006). Once the proper steel was selected, the bladesmith would proceed to work the metal.

To work the metal, a bladesmith would “sandwich” the harder steel around a softer piece of iron. This would allow the blade to flex without having to worry about deformation. When working the metal, the bladesmith would ideally use the softer metal for the core or sides and the harder metal for the point and the edges. The bladesmith would then move onto hammering the metal using tongs, a hammer, a charcoal furnace, and an anvil. Once heated until glowing red hot, the bladesmith would remove the blade and hammer the hot piece of steel on an anvil while moving it back and forth. When hammering the steel, he would need the steel to be hot enough so that it could be worked effectively before it became too cool. This process would be repeated multiple times by hammering then reheating the metal. Once the blade was at the desired length, width, and thickness, the sides, edges, and tang had to be worked to shape (Clements, 2006).

The dimensions of these latter shapes would be instrumental in determining the functionality of the sword. Depending on the type of armor which the blade was trying to penetrate and the manner with which it would penetrate the armor, different blade shapes and curvature was required. The process of

shaping the blade was often the most time-consuming process in forging the sword (Clements, 2006). Once this shape was achieved, the bladesmith would then heat treat the piece of metal. This process was also incredibly crucial in defining the blade's material properties. Heat treating consisted of quenching the blade, which resulted in hardening the steel, then tempering it, which resulted in the softening of the steel (this would occur when the steel was considered martensite). There was no standard for the heat treatment of swords during this time, so the heat treatment depended on the instincts of an individual bladesmith.

Quenching would occur when the glowing hot blade was submerged in a liquid which would drastically lower the temperature. This liquid medium could be either oil or water depending on the steel. This quenched blade would then be gradually reheated using low temperatures. The material properties would noticeably change following the quenching and tempering of the steel blade. Once the blade had cooled, the blade could be ground and polished. This process would be done by hand by honing the edge and point of the specific sword. The grinding would take place using various grits of different stones, often employing a grinding wheel. By turning the blade against numerous different grains of stone, the final shape of the blade could be formed (Clements, 2006). Following this step, further smaller stones could be used to further refine the edge of the blade. A bladesmith would sometimes inscribe the completed blade with some sort of rune or lettering to mark it as his own design.

Upon completion of the blade, a hilt would need to be attached to complete the sword. This hilt would be composed of the pommel, grip, and guard which formed the lower portion of the sword. The hilt was often made from wood, horn, or bone and needed to be able to be gripped firmly without slipping. The guard and pommel would often have their own unique design which was up to the discretion of the bladesmith. Once these pieces were affixed, the sword would be considered finished, simply requiring regular maintenance after it saw service.

### 5.1.2. Traditional Japanese Forging

Due to the nature of the materials of Japanese swords, the creation of blades was a long process that involved a team of people. The largest source of iron on the island were deposits of iron sand that stretched throughout the entire nation. This iron sand contained high amounts of iron-oxides such as magnetite. The high amount of iron in these iron-sand deposits made them the primary source of iron over mining. In terms of sword creation, this iron sand was melting in a furnace called a tataru.

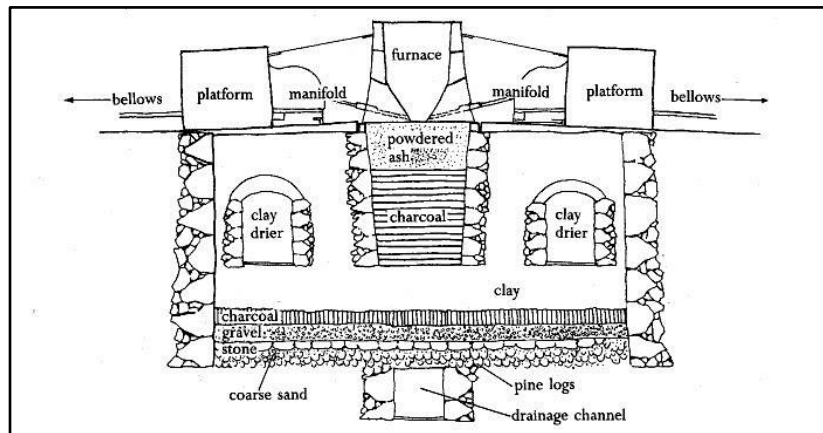


Figure 5.1. Tataru forge (Tatsuo, 2004).

The craftsmen stack alternating layers of iron sand and charcoal in the furnace and heat the furnace to a temperature of about 1200°C to 1500°C. Over a period of three days, the iron collects at the bottom of the furnace. This collection of steel at the bottom is made of several steels with different contents of carbon. The ideal type of steel obtained from this process is known as tamahagane. Tamahagane steel can have a carbon content ranging from 0.6 wt% to 1.5 wt%, however for tamahagane that is considered high quality the carbon content will be 1.0 wt% to 1.2 wt%. For steel that is not within this range, one of two things are done. For high carbon steel, it is placed on a pile of charcoal while air is blown upwards to allow the carbon to escape as carbon dioxide. For low carbon steel, it is forged again with an excess of charcoal covering it to allow the carbon to be absorbed into the metal. Once the steel was prepared, the tamahagane was reheated and broken into small plates. Pieces are then chosen based on their carbon content to form either the harder “kawagane” or the softer “shingane”. These pieces are then stacked on top of one another and covered in a clay slurry and rice paper to maintain temperature and form during a reheating process that will bring the metal up to 1300°C. The pieces are hammered together while heated to form the bars of steel that will be used during forging.



**Figure 5.2.** Tamahagane welded and folded (JNTO, 2020).

Once the bars of steel are prepared, the actual forging process begins. The process typically starts with the “kawagane”. The kawagane bar is heated and is folded in on itself with hammering. The bar is hammered until two halves of equal length are at a ninety-degree angle to each other. The metal is then hammered again until the two halves are completely fused to each other once again. The bar is then drawn until it is twice its original length. This process of folding is repeated multiple times depending on the quality of the metal and the style of the individual blacksmith. Folding the steel is a long process that requires multiple reheats of the metal as it is being hammered. Each fold can require two to three reheats and the steel can be folded up to fifteen times. The smith must also be careful, the heat of the forge means that the steel is easily able to lose carbon during heating and hammering and render the steel useless. Too little carbon in the steel means that it will be too malleable and soft, thus useless when used in a sword. The smith would typically cover the hot metal in clay slurry or rice paper to minimize the amount of carbon lost, but the loss of carbon was inevitable and had to be accounted for in the making of the sword. Once the folded bar is finished and elongated, the steel generally has a non-homogeneous distribution of the carbon which is unideal. To fix this, the smith cuts the bar into equal pieces, stacks them atop one another, and returns the pieces to the forge to fold them once again. At the end of this second forging process a 0.7 wt% carbon steel bar that is homogeneous all around remains at the desired length. One outcome of this repeated folding is the appearance of distinct grain patterns across the blade, giving the blade its distinct visual features.

The Shingane or low carbon part of the blade is prepared in a similar fashion. Folded repeatedly on itself in order to homogenize the steel. The shingane steel will start at around 0.5 wt% carbon content and through repeated hammering will end at around 0.2 to 0.3 wt% carbon. However, the shingane does have to be folded more times than the kawagane as the shingane has more impurities than the kawagane and these impurities must be removed so that the two pieces of metal fuse together.

Once the metals are prepared, they then must be fused together. This can be done in one of two ways. The first way involves hammering the kawagane into a thin plate and then into a U-shape. The heated shingane is then inserted into the U-shape and then the two pieces are heated and hammered so that the two pieces of metal fuse together. There are two important things the smith needs to keep in mind when forging the blade. One is that the kawagane must completely cover the shingane. The inserted shingane bar is shorter than the kawagane in order to achieve this. The tip and edge of the sword must be the kawagane jacket. Second is that there must not be any gaps between the kawagane and the shingane. The two metals need to be completely fused together. If either of these two conditions are not met, the blade is considered worthless, and the metal is recycled. The second way to do this is take the piece of shingane steel and surround it with two to four other pieces of kawagane steel. Either two sides or two sides and an edge and tip. These pieces are then welded to the shingane core. Whichever style the smith chooses, the main construction of the blade is finished after this step.

With the main construction of the blade finished, shaping comes next. During this point, the blade is roughly the same size and shape of the finished product but still requires more shaping for the blade to be considered usable. The smith then denotes the tang of the sword as well as the tip. The tang is the part of the sword that will have the handle fitted over it. The tip is denoted with a rounded edge for later shaping. The smith then hammers the sword so that each part has uniform thickness all around. Finally, the shaping of the blade begins. Six-inch sections of the blade are heated and hammered to flatten out the edge of the blade. The smith slowly works his way down the blade, forming the tip, the flat back of the sword, and the ridgeline of the sword.

Once the shape of the blade is mostly defined, the smith moves on to grinding and filing the blade. This part of the process mainly involves grinding off any excess on the metal in order to smooth the blade out. Then comes heat treatment and tempering. The idea behind the heat treatment of a katana is to make sure the edge, and only the edge, is composed of a type of steel called martensite. Martensite is incredibly strong but also very brittle. So while it holds a strong edge creating an entire blade out of it is unwise as enough force will cause the blade to shatter to pieces. Which is something to be avoided at all costs in the middle of battle. To combat this, the smith uses a type of clay slurry to cover the blade in unequal amounts. The layer covering the back of the blade will be thicker than the layer covering the edge. The smith will also add strips of the clay slurry perpendicular to the blade along with the slurry that is already on there. The purpose of the slurry is to encourage the formation of pearlite and ferrite. These types of steel are much more flexible than martensite, so even if the martensite edge cracks the entire blade will not be destroyed. This process also creates the “hamon” of the blade which is a catch all term for the distinct visual pattern on the blade that comes about from the heat treatment with the clay slurry applied.

Once the clay slurry fully dries, the smith moves onto heat treatment. This process involves running the blade through the forge multiple times with the edge of the blade facing up and multiple times facing down. This is done to homogenize the temperature of the blade. When the steel is a glowing red or orange, it is quickly quenched with water. It is important that the metal does not become too hot.

Otherwise, the blade will crack and the hamon can fade away. If the blade was too cold, then it could simply be redone. The blade is then run through a much lower temperature forge to relieve some of the internal stresses from the rapid quenching.

To finalize the blade, it is polished to reveal the hamon, the curvature is adjusted either by hitting the back of the blade with a hammer to lessen it or by running the back of the blade over a hot copper ingot to increase it. The final work of the smith is adding any decorations to the blade and adding the smith's signature. The blade is then handed off to several different craftsmen to finish the rest of the sword. These craftsmen polish the blade, add copper collars to protect it during storage and add the handguard to the sword, and craft the handle and scabbard of the blade.

## 5.2. Modern Forging Methods

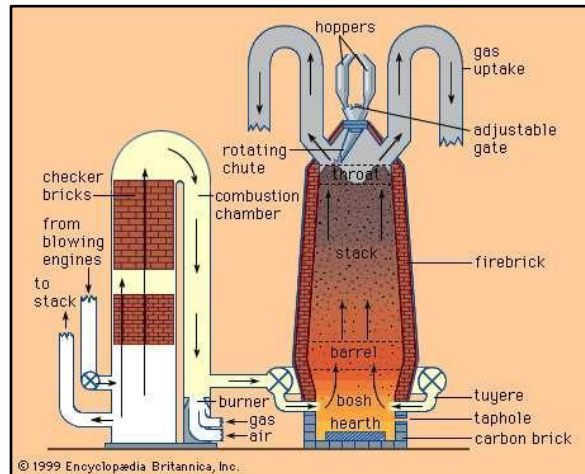
Many blacksmiths today retain much of the traditional methods of sword forging when it comes to both the arming sword and uchigatana. The process for forging the sword remains largely the same, with the largest difference being the tools used to work the metal and the access to more refined materials. The major turning point for the changes in blacksmithing technology occurred with the transition into the Industrial Era (Oldfield, 2020). The introduction of powered machine hammers allowed smiths to use more force and consistently strike points on the sword without the human error of hammering by hand. Steps in the sword making process such as grinding were also aided by the industrial era with grinding wheels being introduced that could spin at much higher speeds. While the steps in making the sword did not fundamentally change, the ease with which a smith could forge a sword changed. The process of gathering material also became more refined as global trade networks began to open. Today, it is much easier to get good steel from global suppliers compared to the Late Medieval Period. Much of the material used for making swords traditionally was inconsistent in terms of quality and heat treatment. Now, the process is much more streamlined, and the composition of the steel is known. Heat treatment is also much more controlled today with many blacksmiths having access to machines which a user can program for specific heat treats compared to using a very hot coal or wood fed furnace. Overall, the large differences in forging today versus traditional methods has to do with the access to raw materials with known properties and the availability of power tools which provide greater advantages to blacksmiths over the traditional handheld ones.



**Figure 5.3.** Example of an industrial power hammer (Blacksmithing, 2014).

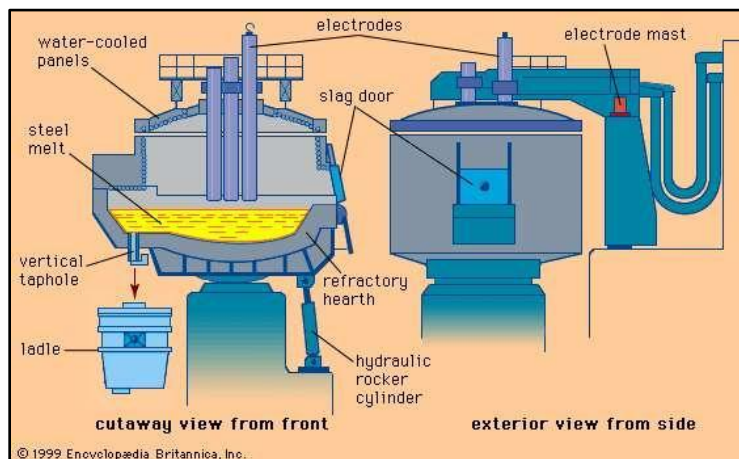


One of the advantages of modern-day forging, and metalworking in general, is the mass production of steel. There are two ways to produce steel en masse. A blast furnace, or an electric arc furnace. Blast furnaces use a special hot burning fuel based around coal called “coke” as well as limestone to melt and purify iron ore into pure iron. The furnace is filled with coke and then blasted with superheated air at 1000°C to cause the coke to react and produce extremely high temperatures, up to 1500°C. The reaction of the coke and the air produces carbon monoxide, which in turn can remove any oxygen atoms that reside within the iron ore and turn it into pure iron. Limestone is added into the furnace to remove any acidic impurities from the iron, such as silica which is a chemical of silicon and dioxide. What is left is a steel of 4-5 wt% carbon composition which is known as “pig iron”. Because of this, pig iron is usually refined to remove a lot of its excess carbon content.



**Figure 5.4.** Example of a blast furnace (Parrott-Sheffer, 2020).

Electric arc furnaces differ from blast furnaces in the way that instead of using the reaction of coke to melt the iron ore, high current electricity is used to melt what is called “scrap steel” to recycle it into other steels. Long electrodes hang from the top of the furnace which can be moved to change the arc length and current flow of the electricity to the scrap. To melt the scrap, the scrap is placed into buckets and is charged with some initial charge before it is lowered into the furnace and the electrodes are put into place. The electrodes melt the scrap down and a slag forms on the top of the molten steel. The steel that is left over has a carbon content that is usually higher than 0.05 wt%, along with other impurities such as nitrogen.



**Figure 5.5.** Diagram of an electric arc furnace (Parrott-Sheffer, 2020).

While traditional blacksmiths used coal forges and many still do, most blacksmiths today use propane forges instead. Propane burns much hotter than charcoal or coal, and it does so much cleaner. This means that heating up the metal to hammer it is much faster and more effective than a coal forge. Propane is like coal in the way that they both create heat by reacting with the oxygen in the air to create carbon dioxide and water vapor with the heat being a byproduct of that reaction. Therefore, the way propane forges work is by connecting a tank of propane to an internally heat resistant forge that also allows for large amounts of air to be sucked into the forge. This allows the propane to react and create the heat.



**Figure 5.6.** Example of a propane forge.

Once the steel is smelted, it is then “rolled” in one of two ways. This means there is some post-smelting process to shape and lengthen the steel in certain ways. Hot rolling involves shaping the steel when it is above what is called the crystallization temperature which is above 538°C. Once the steel is shaped it is cooled at room temperature to avoid the internal stresses of rapid cooling. Since the cooling is non-homogenous, this can alter the shape and size of the final material in unexpected ways. This also gives hot rolled steel a much scallier looking surface finish, though this can be alleviated through grinding or sand blasting. Cold rolled steel conversely is done at room temperature using a roller. Using strain hardening, it is also much stronger than hot rolled steel. The steel also does not deform like it does during hot rolling making it much easier to create precise shapes using cold rolling. Finally, the finish of the steel after cold rolling is smooth and shiny so there is no need from grinding after rolling is complete. One key advantage hot rolling has over cold rolling is that hot rolled steel is much cheaper to produce than cold rolled steel. Therefore, hot rolled steel is still used in many projects where precision and aesthetics are not high priority.

An alternative to forging that is commonly used for mass manufacturing is the process known as “casting”. There are several variations of casting, but the most common type is die casting. The process involves melting down metal until it is molten and injecting that molten metal into steel molds called “dies”. These dies are usually made in halves and then brought together in a machine as the molten metal is injected into it. The metal is then rapidly cooled, the die halves separated, and the “casting” is then ejected from the die. The metal is injected in one of two ways. One way has the mechanism which holds the die inserted into a pool of molten metal along with a plunger. When the plunger opens the metal enters the die where it is then cooled. Once cooled the die is ejected and more metal enters the die. This method is usually reserved for metals that have a low melting temperature. The second method

instead has the metal “labeled” into a cold chamber where it is then injected into the die, meaning the mechanism which holds the die is not submerged in molten metal. This method is generally reserved for metals with higher melting temperatures and is slower than the previous method.

There are pros and cons to using either casting or forging. Casting has the advantage of making parts faster and with a greater variation in shape. As making an adjustment to the shape of a part would simply involve changing the die used in casting. Unfortunately, due to the nature of the casting process, cast metal has much lower tensile strength than forged metal in both yield strength and ultimate tensile strength. Meaning that cast metals will both deform easier and be subject to failure easier. While forged metals are consistently stronger than cast metal, forging does have less freedom in how the metal is shaped and any modifications to the shape are difficult to make. In terms of making weapons, forging is the best option as having a sword with a high tensile strength is very important so that it does not bend or break during use. The advantages of casting are irrelevant to weapon making as high variation in shape should be avoided and the speed of which they could be produced would be counteracted by how easily the weapons would break during use.

A common practice for sword makers around the world across time is to leave a “signature” of sorts on the blade. This is done for identification purposes and could be used to either show the coat of arms whomever carried the blade, a royal insignia, or an identification for whomever created the sword. The technique used to create the signature on the sword is called “stamping”. The general process is as such: A die is placed on a piece of metal which has the image of whatever the smith wants to stamp onto the metal. The die is then struck with a heavy force which then implants the image of the die onto the metal. There were more specialized stamping machines that were made for more specific jobs such as the screw press, which was created specifically for stamping silver coins. Rather than striking repeatedly with a hammer a screw is tightened and turns a rotational force into a directional force which then stamps the metal. However, the general process remained the same throughout time; applying a single strong long-lasting force to shape the metal in a specific way.

In the modern day there are three major types of stamping/pressing that are used in mass production. The first of which is called progressive die casting. A sheet of metal is rolled through a machine with several different stamping stations each of which applies a different stamp or bend to create a finished product. The process can be slow, so this is usually reserved for parts of high complexity. The second being fourslide stamping. Material is fed into a machine and four tools simultaneously bend and press the material into the desired shape. Since there are four different tools working at once there is a lot of versatility with how each piece is manufactured as a different tool can cause a bend or press in a different way. The third major method of stamping is known as deep draw stamping. A metal sheet is pulled into a die with a press and is forced into a specific shape. This is best used for parts that have varying diameters across its shape.

For this project we will be using many of these more modern techniques and technologies when forging the replicas of the swords. The steel that will be used is cold rolled steel that will be heated in a propane forge to shape it. For hammering we will use a mix of both typical hammering for more precise hammer strikes as well as a hydraulic power hammer. These modern techniques will be used in the name of saving time as forging a single sword using only traditional techniques can take months of work. A more detailed explanation of the process used to forge the replicas as well as the outcomes will be given in the following chapters.

## 6. REPLICA CONSTRUCTION

### 6.1. European Arming Sword

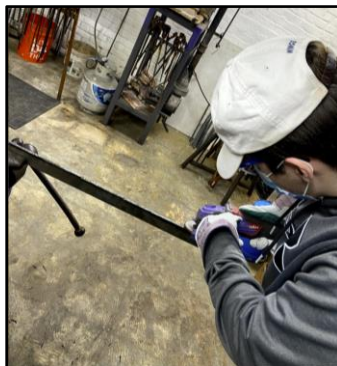
#### 6.1.1. Preparation

Prior to ordering the 1075 steel, we consulted Josh (the blacksmith) to determine the right dimensions to order for the raw stock and where we should order it. After this consultation we decided to order a rectangular bar of 1075 steel from New Jersey Steel Baron, in the dimensions of 120 cm (L) x 6.5 cm (W) x 0.65 cm (T). While Josh recommended that we order the steel 5 cm. wide, it was unavailable on the website, so we decided to order the steel as is and trim the steel down. This step required that we use a plasma cutter, which we were able to use in the WPI Washburn Shops. We marked the bar using a sharpie marker and a straightedge to cut along the proper line, as shown in Figure 6.1.



**Figure 6.1.** 1075 steel marked for plasma cutting.

Following the plasma cutting, the steel was at the proper thickness, but residual slag, or residual chunky metal left from the superheated metal, remained on the outside of the beam. On our trip to the forge, we first had to chip and trim the slag off of the 1075 steel bar that was left over. The 1075 steel bar was held in a vice clamp while we used a chip hammer and angle grinder to make the bar smooth. With the removal of the slag, the steel bar was now ready to be forged.



**Figure 6.2.** Angle grinding the residual slag of the 1075 steel bar.

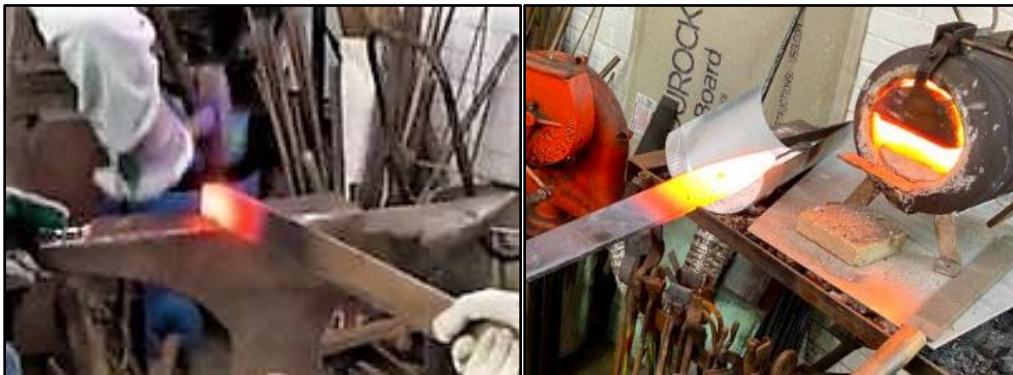
## 6.1.2. Forging

Now that the bar of 1075 was fully prepared, it was time to light the small forge. We hooked up our tank of propane, turned on the fans, opened the gas line, and ignited the flame with a blowtorch.



**Figure 6.3.** Small propane forge heating up.

The 1075 bar had to be left in the forge until it was hot enough to hammer which was indicated by a glowing yellow/orange color. Fortunately, the bar was long enough to hold with just gloves instead of calipers which gave us more control when hammering on the anvil. The first objective was to shape the end of the bar into a sword-like point. This was done by placing the bar on its side and striking top at an angle. Using the force exerted by both the hammer and the anvil, the hot metal was drawn out into a point. Heat was lost the longer the 1075 steel bar was out in the air and being hammered on the anvil which means it had to be quickly placed back in the forge.



**Figure 6.4.** Hammering the blade point on the anvil.

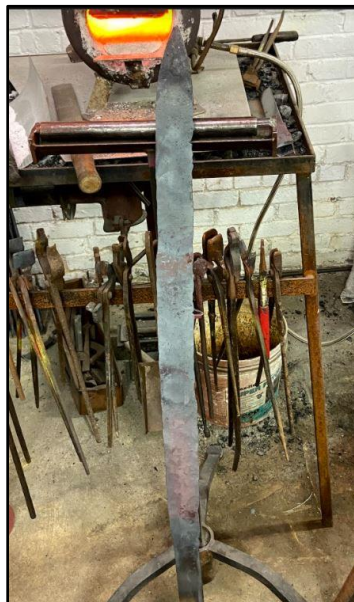
After the tip of the blade was sufficiently shaped, it was time to widen the blade and bevel down the length of the bar. We were able to progressively heat further down the bar since the forge had a hole in the back for the blade to be pushed through. We slowly hammered from the tip all the way down the blade until we stretched it out to our desired length.



**Figure 6.5.** Working the bevel down the length of the blade.



**Figure 6.6.** The final beveling towards the base of the blade.



**Figure 6.7.** The results of beveling and widening the blade.

The next step after beveling was drawing out the tang with what remained of the unforger bar at the end of the blade. The tang is the end of the blade where the cross guard, handle, and pommel are all fitted. At this point we switched from the smaller forge to the larger forge as it would be able to heat the 1075 steel much hotter making it easier to shape.

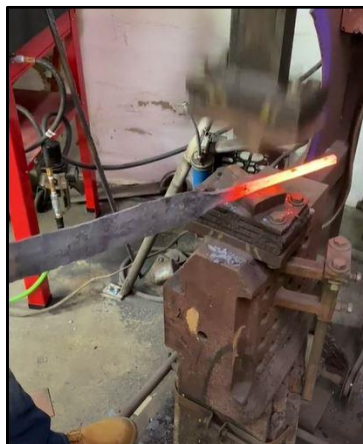


**Figure 6.8.** The large propane forge with raising doors.

As stretching a large amount of steel into a tang would have been difficult to accomplish with just a hammer and anvil, we opted to use the power hammer. The power hammer is a belt powered hammer arm that is attached to an electric motor. Pressing down on the foot pedal activates the electric motor belt which causes the large hammer arm to be forced up and down. This exerts an extreme amount of force on the hammer die (an interchangeable set of steel forms) that act as the hammer and anvil. With the large mechanical force advantage, we were quickly able to stretch the remaining 1075 steel into a symmetrical tang.

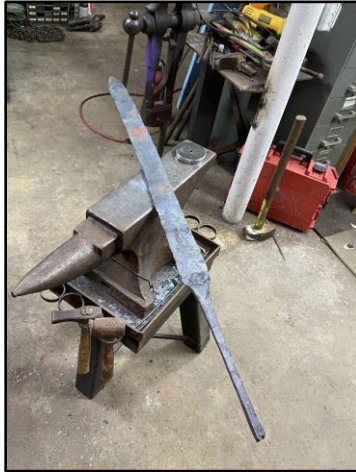


**Figure 6.9.** The power hammer striking the hot 1075 steel.



**Figure 6.10.** The tang almost stretched out to full length.

The tang ended up being too long for our swords handle so we had to trim it down. In the shop there was a metal cutting saw which was able to trim off all the access metal.

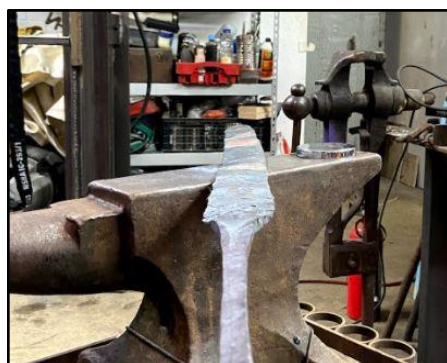


**Figure 6.11.** The sword after forging was complete.



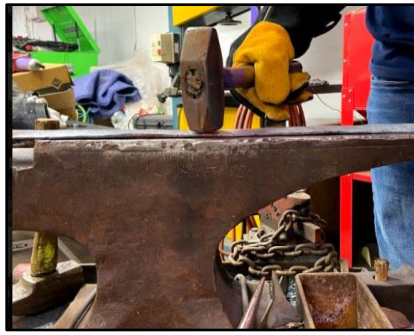
**Figure 6.12.** The metal cutting saw trimming off metal from the tang.

At this point in the forging process, we were satisfied with the overall structure of the blade and finished beveling. However, the blade did have some warping and was not as straight as we needed to move on. To correct the deformities, we used the big forge and only slightly heated up the blade to a dark red. This allowed us to make minor corrections down the length of the blade by hammering lengthwise along the anvil. Since the metal was not glowing bright yellow/orange, it gave us perfect control over the corrections we made to perfectly straighten the sword.



**Figure 6.13.** The blade with slight deformities after beveling.





**Figure 6.14.** Hammering the warm blade along the length of the anvil.



**Figure 6.15.** The final product after blade was straightened.

### 6.1.3. Grinding

Now that the blade was straight and in the general profile we wanted, it was time to move forward with grinding. Grinding is the process of removing metal with large belts of high grit sandpaper. This allows for a more precise shaping of the blade as it removes metal along. When grinding our blade, we first drew a rough outline of the sword with a marker so we knew which parts needed the most metal removed. For this entire stage we used the 40 grit sandpaper belts and set the speed to 6000 rotations per minute (RPM). Paired with a flat table attachment this allowed the steel to be easily grinded off with precision. The grinding setup and first round results can be seen below.

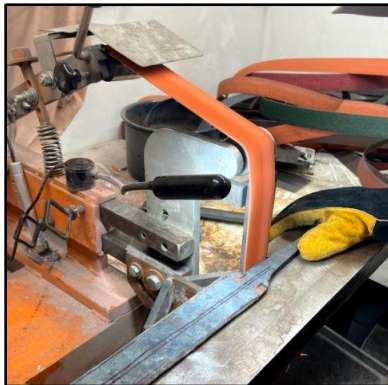


**Figure 6.16.** The grinding belt setup with the flat table attachment.



**Figure 6.17.** The sword after one round of grinding and leveling the edges.

After removing a bulk of the steel from the sides, we took to shaping the tang of the blade which will be where the cross guard, handle, and pommel are all going to be fitted. The outline we wanted here was also drawn onto the blade by a marker. Then by positioning the grinding belt where it hangs over one side of the roller, controlled cuts were made into the metal on both sides.



**Figure 6.18.** The tang being shaped into the blade.



**Figure 6.19.** The tang after it was fully cut into the blade.

Finishing the tang gave us a better outlook of the overall sword dimensions and we realized the blade was too wide in the mid-section. After redrawing a new sword outline on the other side of the steel

blade, we did a second round of grinding the sides to taper the sword more aggressively toward the top. The resulting sword can be seen in Figure 6.20.



**Figure 6.20.** Finished sword dimensions.

The next part of grinding is beveling which gives the sword its distinct diamond cross section with a line straight up the middle. We set up the wheel attachment for the grinder and removed the tabletop.



**Figure 6.21.** Grinding sword bevels with wheel attachment.

To achieve the desired shape, the sword had to be firmly pressed into the wheel at the angle which allowed the most contact. It would then be moved down the wheel in straight passes to grind its entire length.



**Figure 6.22.** The sword bevel almost finished.

After the bevel was grinded into the blade it was time to make the cross guard. This was forged and grinded down to the shape that fit the proportions of our sword. To fit it onto the tang, a few holes were drilled into the middle and the excess metal was filed down. We slid it up the tang after there was a sufficient gap.



**Figure 6.23.** Cross guard profile being grinded down.



**Figure 6.24.** The blade with cross guard attached.

Lastly the pommel was cut from a scrap metal bar in the shop and grinded down like the cross guard. It was affixed by also drill pressing a hole and trimming out the excess metal with a file. Once the hole was large enough, the pommel was wedged on the end of the tang. Both the cross guard and pommel were welded onto the blade to ensure they stayed in place. To finish the replica, the exposed tang was wrapped with a thick layer of brown waxed cord to shape the handle. The final arming sword replica is seen in Figure 6.25.



**Figure 6.25.** Final arming sword replica.

## 6.1.4. Heat Treatment

As discussed earlier, heat treatment of the finished blade was not feasible due to furnace size limitations and a high chance of distortion during quenching. After considering our options, we decided the best path forward was to only heat treat the similarly forged small bar of 1075 steel, and perform the microstructure analysis on this equivalent piece instead. This decision was also made on the basis that our arming sword replica was only being used in display, and would see no practical benefit of performing the heat treatment. The heat treatment was the same as presented previously in Section 4.3.3.



**Figure 6.26.** 1075 carbon steel sample bar during normalizing cycle.



**Figure 6.27.** Quenching the sample after austenitizing.

## 6.2. Uchigatana

### 6.2.1. Preparation

The uchigatana used the same plasma cut 1075 steel that was used for the European arming sword. This was done after the cutting and grinding off of the residual slag so there is no difference in the preparation of this metal for the two swords. The piece of 1075 used was thin so it would be surrounded by the 1045 steel. The only preparation the 1045 steel required was cutting it to a proper length for the sword. Unfortunately, we did not cut the proper length of the 1045 or 1075 for the sword as it did not reach the minimum goal of 80cm, but it did reach the proper width.

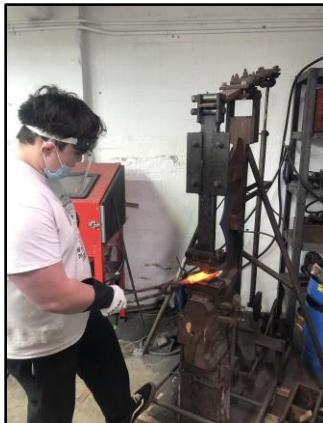
## 6.2.2. Forging

Once the forge was lit, the first step was to mold the 1045 metal into a “U” shape down its entire length. This was done by heating up a portion of the metal until glowing and then using a peen hammer to hammer it into a U-shaped mold. This was done down the entire length of the metal to give a “taco” shape. Once the 1045 had the taco shape, a thin piece of 1075 was slotted into the steel taco and was placed into the furnace. A portion of the 1075 stuck out of the steel taco on the backside as that portion would act as the tang and an easy gripping point for tongs. Once a portion was properly heated, it was hammered using the shop’s hydraulic hammer to fuse the two metals together. This again was done down the entire length of the length of the steel taco except for the piece of 1075 that was sticking out.



**Figure 6.28.** Bar of fused metals.

Once the metals were properly fused together, it was finally time to start stretching and beveling. The metal was first stretched out using the hydraulic hammer to reach a more proper length as well as thin it out to make hammering easier. Beveling was done on only one side as a one-sided blade is traditional for an uchigatana. The fused metals were hammered until the metal finally resembled a blade. The beveling also helped stretch the blade out to a more proper length.



**Figure 6.29.** Stretching and beveling the blade.

At some point, the tip of the blade became misshapen. Rather than try to hammer out a fix for it, after we returned to the shop the first thing we did before heating the blade was cut off the tip at an angle to somewhat resemble what the traditional uchigatana tip would look like. The portion that was cut off would then be used for microstructure analysis for the fused metals.



**Figure 6.30.** Blade with the misshapen tip removed.

As the beveling and stretching continued, there was some structural instability that appeared at one point. Near the tang, the 1075 and 1045 did not properly fuse, leaving a structurally unsound portion of the blade that was at risk of falling off if improperly handled. After consulting the blacksmith, he recommended avoiding that area as much as possible during the beveling process. As expected during the beveling process, the blade became warped and curvy.



**Figure 6.31.** Warped blade prior to straightening.

The straightening process involved placing a portion of the blade into the furnace, and either hammering it down flat onto the anvil, or using a vice and tightly squeezing the blade in its grip. To give a slight curve to the blade, it was first hammered on its cutting edge to straighten the blade as much as possible. Then a portion near the top of the blade was heated up until glowing. The blade was then placed on the rounded portion of the anvil and hammered on its cutting edge to give the blade a small curve.



**Figure 6.32.** Blade after curve was hammered out.

### 6.2.3. Grinding

The grinding setup for the uchigatana was identical to the setup for the arming sword. The first step in grinding was to get rid of all the flaking on the exterior of the blade and tang to make the blade look as shiny as possible.



**Figure 6.33.** Blade after carbon scaling was partially ground off.

Once all the flaking was removed, the blade was beveled further, and parts of the blade were thinned down to keep the dimensions mostly even. The beveling was done to give the blade somewhat of a triangular shape with the blade at its thickest down the center line. Removing the flakes from the blade also revealed several more structural errors such as cracks and cavities. Many of these were removed during grinding but some had to remain due to time constraints. The blade continued to be beveled and ground down to make it as shiny as possible and resembling the profile and shape of an uchigatana. The finished product is shown below.



**Figure 6.34.** Final blade product after grinding.

The sword cross guard and handle were then finished in the woodshop. The wood pieces were cut and attached to the end of the grinded blade to produce the final uchigatana replica, shown in Figure 6.35.





**Figure 6.35.** Final uchigatana replica.

#### **6.2.4. Heat Treatment**

Due to same constraints discussed for the arming sword, the uchigatana was not heat treated. However, both blades would have gone through the same heat treatment process, which was specified earlier in the arming sword section. A similarly forged-welded small bar was heat treated for microstructure analysis.

## **7. CONCLUSIONS**

Following a similar process of forging as a blacksmith in late medieval Europe gave us much insight into vast and practical knowledge they possessed that was far ahead of their time. While it must have taken years of trial and error, arming swords were forged, and heat treated in a manner that gave them the desired hardness and flexibility to be lethal on the battlefield. Using the technology we possess in the modern era, we are able to understand more about what our actions throughout the forging process accomplished and how to perform them with greater efficiency and success rates.

Hammering and grinding the sword into our desired replica's final shape was a complex process that would take many years to master. However, the most impressive aspect of late medieval blacksmithing in Europe was the developed ability to heat treat a blade with such limited and rudimentary methods such as watching the color of molten metal. Even with modern technology like an automated kiln and tailored quenching oil, our groups still avoided heat treating our replica as there was the concern it could be deformed in the process. Fortunately, the microstructure analysis of our smaller carbon steel samples proves the functionality and effectiveness of the heat treatment process that evolved from the similar methods used in medieval Europe.

Similar to the arming sword and following a concurrent time period, the Japanese mastery of sword making at the time is astounding. The Japanese techniques they developed for creating a strong yet durable sword are still in use today because the superb quality of the final product remains the same. While the group had very little experience with blacksmithing, particularly compared to a true Japanese swordsmith, it gave us greater insight into the technical challenges of making an uchigatana. Using a balance of modern and traditional techniques for creating the sword also allowed us to understand what modern methods in forging have allowed modern day blacksmiths to achieve compared to their ancestors. While our replica uchigatana was not heat treated, the microstructure of the small pieces that were, demonstrated the successful properties that the blade would have had should it have been heat treated.

# APPENDIX: WEBSITE ADDITIONS

We used a code editing software called “Brackets” to make changes to the IQP website. Once we had all our pictures of the replica construction and background chapter selected, we added our text into the html code format in the software. The following sections are the text and picture additions we made to The Historical Evolution of Arms and Armor website. This is in addition to updating the interactive map with our replica’s origin location hyperlinked to our pages.

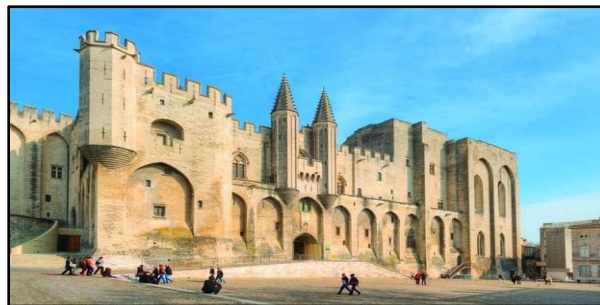
## A.1. European Background

The Late Medieval Age was preceded by the High Medieval Age, which many scholars believe represented the peak of Medieval civilization. Beginning around the 11th century and lasting until the 14th century, the High Medieval Age bore witness to countless important events. These included the Norman conquests in Britain and Sicily, the Early Crusades, and the signing of the Magna Carta. Feudalism was established across nearly all of Britain as well as other parts of Europe, creating a defined social structure and allowing trade to flourish. This would not last forever, as numerous cataclysmic events would occur in the 14th century, signaling the end of the High Medieval Age.

### Major Events

#### The Avignon Papacy

Starting the turmoil of the late medieval period, the Avignon Papacy was the event in 1309 AD that sparked years of religious strife. This event was the 70-year period where all the consecutive popes chose to reside in the French city of Avignon. While seemingly innocent in nature, it was shocking to the public that the papacy took permanent residency outside of Rome. The presence of such religious authority had become expected and almost a necessity to ensure a strong faith among the masses. With the robust shift of power to France and consequent French Majority in the Sacred College of Cardinals, nations such as England, Italy, and Germany grew opposed. Overall, what seems just a simple move of seven consecutive popes to France completely waived the faith of medieval society and served as the catalyst for much future conflict/crisis of the late medieval period.



#### The Black Death

The next crisis was one of most devastating events in European history: the Black Death pandemic. The Black Death killed over 25 million people, which makes it one of the worst diseases in all of human history. During the late medieval period when Europe was already suffering from growing tensions between nations, warfare, and famine, the Black Death was truly the nail in the coffin. It started in 1346 AD when Mongolian

warriors developed the bacterial disease from rodents. This passed through the Black Sea to the outpost of Caffa as the Mongols attacked, who even hurled the infected bodies of their fallen soldiers over the walls. It was from here that Caffan trade ships brought the disease to main populations of Europe leaving a wake of death in their path. By the end of 1349, the majority of Europe had suffered from the Black Death including France, Spain, England, and Ireland. The reason it spread so rapid was there was no treatment knowledge for bacterial diseases such as this, and the standards of public health were so terrible it provided the perfect environment for the Black Death to wreak havoc on Europe. After 7 years of suffering, finally in 1353 the disease faded out. However, the effects of the severe death toll and social consequences could be seen in Medieval Europe for centuries after. Roughly 30-50% of the population infected by Black Death was killed fluctuating between areas and living conditions. The social consequences of such a quick drop of population were immense and the structure of society was truly left broken. The credibility of all different kinds of “authority” including nobility and religion were tarnished as citizens sought to place blame for the unceasing death. This chaos and breakdown of society continued for years and ongoing/future events such as the Western Schism were only amplified by the Black Death (Cartwright, 2020).



## The Western Schism

The Western Schism was the one of the last major events of the Late Medieval period and started in 1378. This great authority crisis directly succeeded the events of the Avignon Papacy that ended in 1377 and would be the toughest challenge the medieval church ever faced. At this time, Gregory XI was elected pope on the promise that he would bring the papacy back to its original glory in Rome. While he did briefly fulfill this promise, Gregory XI's unexpected death in 1378 started a snowball effect that would forever disrupt the high status of the papacy. The new pope to take his place was an Italian named Urban VI, who achieved support by taking a stance against the majority French religious control that had resulted from the Avignon papacy. The Sacred College of Cardinals were appalled by this notion and all but a few Italians retreated to France, as they sensed it was their best possibility to maintain power (Canning, 2011). Once arriving back in the French city of Avignon, the cardinals discredited pope Urban VI in Rome and appointed a second pope named Clement VII. This radical move of the French cardinals would entirely split the medieval church in Europe and create two pope lineages: Roman and French. However, with the ongoing Hundred Year's war already high tensions between nations, a strong rivalry of religious authority began. Pope Urban VI in Rome was backed by England, who was at war with France, and the Germanic Holy Roman Empire. Pope Clement VII in Avignon was supported by the Spanish and England's rival of Scotland. Overall, this was hugely destructive because it not only upset what little religious faith the public had left, but it also took away all authority and economic stability of the medieval church. Society was exposed to the true desires of the papacy that were the worldly glories of power and money. This lasted years

as countless groups tried to remedy the innate corruption of the church by unifying the papacy to no avail. It only made matters worse as in 1409 the Council of Pisa elected a new pope, Alexander V, to depose the existing two papal lines and instead just created a third pope. It was not until 1417 that the Council of Constance finally resolved the Western Schism by accepting the Roman line's claim to papacy (Seminary, 2014).

## The Hundred Years War

The Hundred Years' War was one of the longest lasting conflicts in known human history, starting in 1337 and ending in 1453. The roots of this conflict can be traced back to the challenge of the French throne by Edward III of England, following the death of Charles IV. Tensions between the two kingdoms had existed long before this incident, but it proved to be the spark in the proverbial powder keg. Edward III used his claim to the throne as a way to gain allies within France who were discontent with their current rule. He was able to find allies in the Flemings and a number of French nobles (Gascoigne, 2001). With these alliances Edward was able to keep certain French territories isolated from French rule. In 1346, Edward III would lead the English to victory over the French at the Battle of Crécy and would follow this with a successful siege at Calais (Keen, 2011). Edward's heir known as the Black Prince would lead two successful offensive attacks on the French. One of these was the Battle of Poitiers, which resulted in the capture of John II, successor to the French throne. Holding the French king for ransom, in 1360, Edward was able to negotiate for a large portion of money in addition to French land, under the condition that he renounced his claim to the French throne. Peace lasted for 9 years until French and English disputes resulted in the renegeing of the negotiations made years prior. While hostility remained present between the two kingdoms, both were war weary and both countries attempted to negotiate peace. In 1413, the English king Henry V seized the opportunity to attack France when civil war plagued their country. Henry launched numerous sieges in an attempt to conquer territory in 1417. At this point in the war, England was poised to take over a large portion of France with very few obstacles in their way. Northern France sought to negotiate a peace treaty with England while Southern France remained in opposition. In 1429, Joan of Arc would arrive at the French prince's court speaking of divine intervention instructing her to purge France of the English (Gascoigne, 2001). Later in the year with a relieving army, Joan marched on Orléans and successfully broke the siege. Further victories would follow when Joan defeated retreating English forces, until she was burned at the stake in 1431. Charles VII would be recognized as king in France following the victories. In 1444, a general truce was reached between the French and English but was broken when English forces sacked a commune in French territory. This resulted in Charles VII retaliating from 1449-1451 during which time he overran Normandy. On July 17, 1453, the war was ended when the English army was defeated at Castillon and their commander killed (Gascoigne, 2001). While more conflict ensued between the French and English, this date effectively marked the end of the conflict that became known as the Hundred Years' War.



## Armor

### Plate Armor



Full plate armor would develop from steel plates, which were added into various armor components around the 14th century (Roberts, 2019). Full plate armor would become commonplace in the 15th century, often worn by knights. This armor was made from overlapping steel plates that provided excellent protection against blunt strikes and stabs alike. The largest drawback of plate armor was that swords could be thrust within the gaps in the armor. Any soldier wearing full plate armor would be a formidable opponent in battle.

### Chain Mail



Chain mail armor was one of the most rudimentary forms of metal armor that saw use during all periods of the Middle Ages. This armor was useful for providing protection against cuts and slashes from weapons such as swords, spears, and axes. It was also lightweight, easily repairable, and soldiers could move with ease. Chain mail armor was ineffective in providing protection from any weapon, which utilized blunt force trauma. By the 14th century, the use of chain mail armor became more infrequent due to the development of plate armor (Alchin, 2015).

### Shields



Shields were a vital source of protection for soldiers engaging in both melee and ranged combat. Shields could be made from a vast range of materials, the most common of which were wood and animal hide. As the time period progressed, metal would become the preferred material to use in shield fabrication. The shield a soldier used depending on what their purpose in combat was. If the soldiers were required to be mobile and quick on their feet, they would likely have a smaller and lighter shield to improve mobility. Likewise, if an archer were to use a shield, they would be able to afford a larger shield that would provide them with greater bodily protection. The applications of shields in warfare were countless, and both design and material varied depending on said application. Shields would remain an essential part of medieval warfare and onwards until the widespread use of gunpowder.

## Weapons

### Swords



Of all the melee weapons used during the Medieval Ages, the sword was one of the most commonly used. While not used as much by the common foot soldier, the sword was associated with the knight. The types of swords used during this era ranged from smaller swords of about 76 centimeters in length to great swords of more than 175 centimeters in length. Depending on the design of the sword, it would be optimal for either stabbing or slashing. The sword was viewed as symbolic by many, taking a deeper meaning outside of warfare, and would be inscribed by a smith to have value to the sword bearer.

### Spears, Pikes, and Halberds



Spears were another popular melee weapon during the time, but contrary to swords, were more often wielded by the typical foot soldier or peasant. The spear was designed primarily for thrusting although it could be thrown in certain situations. The spear was also much cheaper to produce than a sword while requiring a lot less training. Variants included pikes, halberds, and other long weapons designed primarily for thrusting over a longer range than a sword.

## Daggers



Used as a sidearm for many soldiers, the dagger was a secondary weapon that could only be used in close combat due to the length of the blade. Daggers provided an added benefit of being able to stab between gaps in plate armor as the use of plate armor became more widespread. Daggers could also be employed to cut away armor straps and other equipment if needed.

## Longbows



As ranged weapons are concerned, the longbow was the most prevalent form during the late medieval period and saw heavy use during the Hundred Years' War. Archery was no new concept in Medieval Europe with some of the first bow and arrows being used as early as 3,000 BC in Ancient Egypt (Archery, 2018). With thousands of years of refinement and practice, archery became a status quo of society and soon gave rise to new iterations of the bow. The longbow was exactly that and was a relatively new weapon of Medieval Europe. Due to its towering height of about 6 feet and fabled power, it became a staple weapon during the late medieval. It is estimated that the typical draw strength of a medieval longbow was about 100 pounds which allowed this weapon to send the iron tipped arrows downrange with devastating effect. Due to the longbow, armor such as chainmail was almost nullified as a well-placed arrow could pierce through the toughest mail and even kill horses. It was also so effective because Longbows were so easy to construct only requiring wood such as yew and bowstrings made of flax/hemp (Medievalist, 2015).

## Crossbows



The crossbow was an ideal ranged weapon since it required minimal training to use. The crossbow string could be loaded using either a lever or a cranking mechanism. The crossbow would use a bolt made from metal instead of a wooden arrow. Generally, a crossbowman was considered to be on par with a foot soldier as a lot less training was required for a crossbow than a longbow. With this being said, the crossbow was considerably less accurate than its longbow counterpart.

## A.2. Arming Sword Replica Construction

We started with a bar of 1075 carbon steel that was 120 cm (L) x 6.5 cm (W) x 0.65 cm (T). This was too wide, so we removed 2.5 cm from the side using a plasma cutter. After sketching a rough sword outline and designing a CAD model, we were ready to start forging.



The first step of forging was to draw the end of the bar into a point by holding the bar vertical on the anvil and hammering at an angle. After the tip of the blade was forged, we beveled down the length of the blade. We had to rotate and straighten the sword throughout this process because it often caused warping or twisting of the metal.



The beveling process had to be performed down the entirety of the blade to achieve the desired diamond cross section; with the thickest part of the bar in the middle. Similar to forging the tip, the blade had to be held on the anvil at an angle that stretched out the metal closer to the edge.



The next step was to draw out the tang of the blade. As this would have been very difficult to do manually, we opted to use the power hammer. The hammer arm was attached to an electric motor and would



repeatedly strike when the foot pedal pressed down. The strength and precision of this tool is truly unrivaled by other forging methods.



The final step of forging was to straighten the blade. The result is just a rough shape of the sword as most of the precision and shape comes from the grinding phase.



To prepare for grinding we drew a measured outline on the blade and set up the tabletop grinding attachment. Then we used the belts spinning at 7000 rpm to shave off large quantities of metal getting the exact sword profile we desired.



Throughout the grinding phase we wore proper personal protective equipment including respirators, gloves, eyeglasses, and ear plugs.



The next part of grinding is beveling which gives the sword its distinct diamond cross section with a line straight up the middle. We set up the wheel attachment for the grinder and removed the tabletop.



To achieve the desired shape, the sword had to be firmly pressed into the wheel at the angle which allowed the most contact. It would then be moved down the wheel in straight passes to grind its entire length.



After the bevel was grinded into the blade it was time to make the cross guard. This was forged and grinded down to the shape that fit the proportions of our sword. To fit it onto the tang, a few holes were drilled into the middle and the excess metal was filed down. We slid it up the tang after there was sufficient gap.



Lastly the pommel was cut from a scrap metal bar in the shop and grinded down like the cross guard. It was affixed by also drill pressing a hole and trimming out the excess metal with a file. Once the hole was large enough, the pommel was wedged on the end of the tang. Both the cross guard and pommel were welded onto the blade to ensure they stayed in place. To finish the replica, the exposed tang was wrapped with a thick layer of black cord to shape the handle. The final arming sword replica can be seen below.



## A.3. Japanese Background

### Kamakura Period

The Kamakura period began when Minamoto no Yoritomo became Shogun of Japan. The Shogun was the de facto military leader of all Samurai. The Samurai at the time were a larger military presence than the soldiers of the emperor, this also meant that the Shogun had the true power over the country rather than the emperor. There were also many different individuals attempting to seize power for themselves. The first was actually Minamoto's wife, who attempted to make the Hojo clan the ruling family of the country by creating the position of "regent" – a sort of advisor role to the Shogun that could act in their stead. This lessened the power of the current Shogun Minamoto no Sanetomo, Yoritomo's son.

During this time, a coup was attempted by emperor Go-Toba in order for the emperor to regain its status. This coup ended up failing and the Hojo clan remained the ruling family for many years. Their rule began to weaken after the invasions of the Mongols. Despite the invasions largely being failures, there was still significant economic damage done to the nation. The Samurai began to become disgruntled as this economic damage affected their ability to get paid.

Using this to his advantage, Emperor Go-Daigo launched three different coups against the Hojo clan and Minamoto family to gain control. The third coup managed to succeed after the warlord Ashikaga Takauji betrayed the Shogun and sided with Go-Daigo. This successful coup marked the end of the Kamakura Period and the beginning of Emperor Go-Daigo's reign.

### Muromachi Period

Go-Daigo's reign did not last long as Takauji ended up betraying him to gain the seat of Shogun and establish the Ashikaga family as the ruling family. Takauji went to war with his rival Tadayoshi in order to protect his seat as Shogun, with Takauji assassinating Tadayoshi by poisoning him. There was an uneasy peace until 1467, when two powerful clans, the Hosokawa and Yamana, disagreed on who the next Shogun would be. At this point in time however, the Shogun was merely a puppet to whoever was controlling them, as local daimyo had much more control over their regions of influence than the Shogun could have. The Hosokawa and Yamana gathered smaller clans for support and war eventually broke out. However, this war signaled just how powerless the Shogun was and after this war the period known as the Sengoku Jidai began, where daimyo began to fight for local power and control in the hopes of ruling all of Japan.

## Armor

There were many different types of armor during the time of the samurai that all varied in slightly different ways in terms of trading off mobility and protection but the construction was kept relatively consistent. The armor was made of small interlocking plates tied together using rope, lace, or silk. Each individual piece of armor was put on one at a time. The cuirass protected the torso, while other pieces were put on the upper body to protect the arms and shoulders. This ended up leaving gaps in the armor but this was intended to preserve the mobility of the samurai. At first ashigaru used whatever armor that they looted from the battlefield, ideally from dead samurai, however as ashigaru became more prevalent they were equipped with their own armor. The armor used had similar construction to a samurai's, but the armor used was lighter and less protective to reduce costs, as well as allow for greater mobility. Generally armor got lighter the further from the Heian period as infantry combat became more prevalent over cavalry combat.



## Weapons

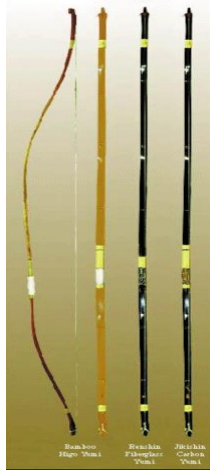
### Uchigatana

The modern version of the uchigatana has a construction that is close to the katana, however the uchigatana came first as a cheap, disposable weapon to be used by samurai and ashigaru. It only reached its mass popularity in the Muromachi Period. The uchigatana started its life in the samurai arsenal as a faster shorter version of the widely used Tachi. The uchigatana's size allowed it to be drawn quickly and even combine the drawing and striking motion into one. This technique was known as "Iaijutsu". The uchigatana lent itself well to this technique due to the way the blade was curved along with the scabbard. Blades were also oiled as a method of preservation while in the scabbard which also reduces any friction between the scabbard and the blade. This quickdraw capability solidified the sword's place as a close-quarters, quickdraw weapon.



## Yami

The bow, or the yami, was typically made with bamboo and was by far the most popular weapon of the samurai. Despite blades such as the katana or the uchigatana being more famous, the yari was the most used and longest lasting of any of the weapons used by the samurai. Even when the arquebus rifle was introduced in Japan, the bow remained one of the most used and most effective weapons. This is for a few reasons. One being that a large volley of arrows in a group of enemies is devastating. Especially since samurai typically did not use shields. The bow also helped with sieges. Many Japanese castles were located on tall hills and difficult to assault. Having a samurai shoot up with incredible accuracy could turn the tide of the assault. Conversely, samurai shooting down at opponents from a high place could devastate an assaulting force. This popularity of the bow caused the creation of its own martial art called Kyudo. Combining a samurai's accuracy with the bow with the mobility that a horse allows turns a samurai into a serious threat.



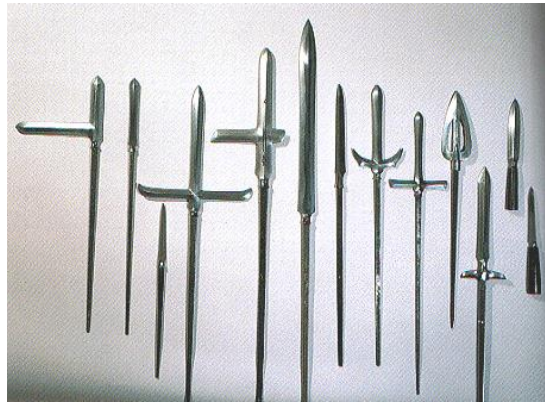
## Tachi

The tachi was the precursor to both the uchigatana and the katana. Like those two swords it featured a curved blade but its length and weight were greater. This was to increase its lethality especially on horseback. After the invasions of the Mongols, the blade became even heavier and longer to further increase its effectiveness, as well as make it more effective against soldiers on horseback. The tachi remained the go to sword of the samurai until the rise and popularity of the uchigatana.



## Yari

The Yari was a version of the spear that emerged during the invasions of the Mongolians. Weapons similar to the yari were used by conscripts before the widespread presence of the samurai as a cheap way to arm peasants. However once the samurai rose to prominence, the original spear was almost completely fizzled out of military tactics in favor of the bow and horse archery. The large pressure that the Mongols placed on Japanese infantry is what caused the re-adoption of the spear. Allowing units to pack together and stop cavalry in their tracks. Yari also could have many different kinds of tips depending on how it was made and how it was planned to be used. Since the tips were also bladed, they could be used either by thrusting or by slashing.



## Naginata

There was another polearm weapon used at the time known as the naginata. This was a glaive-like polearm with a curved blade rather than a point. While not as widely used as the yari for samurai, this polearm gained a lot of popularity with local warrior monks, such as the Ikko Ikki. This popularity likely stemmed from its adaptability, being longer than a sword gave it an advantage in close quarters while also helping deal with cavalry. While it has a disadvantage of being incredibly hard to use meaning it required a lot of training to use properly, this was not much of a problem for the warrior monks, as they would essentially dedicate a part of their lives to the study of martial arts.



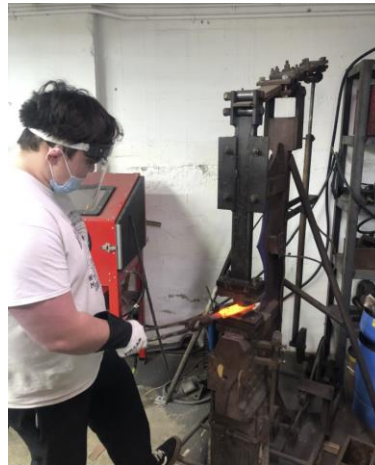
## A.4. Uchigatana Replica Construction

The uchigatana used the same plasma cut 1075 steel that was used for the European arming sword. This was done after the cutting and grinding off of the residual slag so there is no difference in the preparation of this metal for the two swords. The piece of 1075 used was thin so it would be completely surrounded by the 1045 steel. The only preparation the 1045 steel required was cutting it to a proper length for the sword. Unfortunately, we did not cut the proper length of the 1045 or 1075 for the sword as it did not reach the minimum goal of 80cm but it did reach the proper width.

Once the forge was lit, the first step was to mold the 1045 metal into a “U” shape down its entire length. This was done by heating up a portion of the metal until glowing and then using a peen hammer to hammer it into a U shaped mold. This was done down the entire length of the metal to give a “taco” shape. Once the 1045 had the taco shape, a thin piece of 1075 was slotted into the steel taco and was placed into the furnace. A portion of the 1075 stuck out of the steel taco on the backside as that portion would act as the tang and also an easy gripping point for tongs. Once a portion was properly heated, it was hammered using the shop’s hydraulic hammer in order to fuse the two metals together. This again was done down the entire length of the length of the steel taco except for the piece of 1075 that was sticking out.



The beveling process had to be performed down the entirety of the blade to achieve the desired diamond cross-section, with the thickest part of the bar in the middle. Similar to forging the tip, the blade had to be held on the anvil at an angle, which stretched out the metal closer to the edge.



At some point, the tip of the blade became misshapen. Rather than try to hammer out a fix for it, after we returned to the shop the first thing we did before heating the blade was cut off the tip at an angle to somewhat resemble what the traditional uchigatana tip would look like. The portion that was cut off would then be used for microstructure analysis for the fused metals.



As beveling and stretching continued, there was some structural instability that appeared at one point. Near the tang, the 1075 and 1045 did not properly fuse, leaving an incredibly structurally unsound portion of the blade that was at risk of falling off if improperly handled. After consulting Josh (the blacksmith and owner of the shop), he recommended avoiding that area as much as possible during the beveling process. As expected during the beveling process, the blade became incredibly warped and curvy.



The straightening process involved placing a portion of the blade into the furnace, and either hammering it down flat onto the anvil, or using a vice and tightly squeezing the blade in its grip. In order to give a slight curve to the blade, it was first hammered on its cutting edge to straighten the blade as much as possible. Then a portion near the top of the blade was heated up until glowing. The blade was then placed on the rounded portion of the anvil and hammered on its cutting edge to give the blade a small curve.



The grinding setup for the uchigatana was identical to the setup for the arming sword. The first step in grinding was to get rid of all the flaking on the exterior of the blade and tang to make the blade look as shiny as possible.



Once all the flaking was removed, the blade was beveled further and parts of the blade were thinned down in order to keep the dimensions mostly even. The beveling was done to give the blade somewhat of a triangular shape with the blade at its thickest down the center line. Removing the flakes from the blade also revealed several more structural errors such as cracks and cavities. Many of these were removed during grinding but some had to



remain due to time constraints. The blade continued to be beveled and ground down to make it as shiny as possible and resembling the profile and shape of an uchigatana.



The sword cross guard and handle were then finished in the woodshop. The wood pieces were cut and attached to the end of the grinded blade to produce the final uchigatana replica, as seen below.



## REFERENCES

### Literature:

Albion. "The Knightly Sword (Type XII)." *Albion Swords Ltd*, 2020, <https://www.albion-swords.com/swords/albion/nextgen/sword-medieval-knight-xii.htm>

Alchin, Linda. "Chainmail." *The Middle Ages*, Mar. 2015, [www.lordsandladies.org/chainmail.html](http://www.lordsandladies.org/chainmail.html).

AMS, Resources. "Carbon Steel." *Alloys, Metals & Steels Supplier*, 2020, [amsresources.com/1074-1075/](http://amsresources.com/1074-1075/).

Anonymous, Tg. "Yari Heads." *Traditional Games*, 30 June 2014, [warosu.org/tg/image/BHYbRPxagFUHnca\\_40o0rA](http://warosu.org/tg/image/BHYbRPxagFUHnca_40o0rA).

Archery, World. "History of Archery." *World Archery*, 5 Dec. 2018, [worldarchery.org/History-Archery](http://worldarchery.org/History-Archery).

AZoM. "AISI 1045 Medium Carbon Steel." *AZoM.com*, 5 July 2012, [www.azom.com/article.aspx?ArticleID=6130](http://www.azom.com/article.aspx?ArticleID=6130).

Britannica, Editors. "Wars of the Roses." *Encyclopædia Britannica*, Encyclopædia Britannica, Inc., 15 Oct. 2020, [www.britannica.com/event/Wars-of-the-Roses](http://www.britannica.com/event/Wars-of-the-Roses).

Bodycote. “Tempering - Hardening and Tempering - Bodycote Plc.” *Bodycote*, 2019, [www.bodycote.com/services/heat-treatment/hardening-and-tempering/tempering/](http://www.bodycote.com/services/heat-treatment/hardening-and-tempering/tempering/).

Callister, William D., and David G. Rethwisch. *Materials Science and Engineering An Introduction*. 9th ed., John Wiley & Sons, Inc., 2014.

Canning, J. (2011). The power crisis during the Great Schism (1378–1417). In *Ideas of Power in the Late Middle Ages, 1296–1417* (pp. 165-191). Cambridge: Cambridge University Press. doi:10.1017/CBO9780511984532.009

Cartwright, Mark. “Black Death.”, “Hundred Years War”, “Medieval Knights”, *Ancient History Encyclopedia*, Ancient History Encyclopedia, 2020, [www.ancient.eu](http://www.ancient.eu).

Clements, John. “How Were Swords Really Made?” *The Arma*, The Association for Renaissance Martial Arts, May 2006, [www.thearma.org/essays/How\\_Were\\_Swords\\_Made.html](http://www.thearma.org/essays/How_Were_Swords_Made.html).

Concordia. “Avignon Papacy Begins.” *Reformation 500*, Concordia Seminary, St. Louis., 12 July 2016, [reformation500.csl.edu/timeline/avignon-papacy-begins/](http://reformation500.csl.edu/timeline/avignon-papacy-begins/).

Cullman. “Carburizing Process.” *Advanced Heat Treat Corp.*, Spinutech, 2020, [www.ahtcorp.com/services/traditional-conventional-heat-treat/carburizing/](http://www.ahtcorp.com/services/traditional-conventional-heat-treat/carburizing/).

Drees, Clayton J. *The Late Medieval Age of Crisis and Renewal: 1300-1500: a Biographical Dictionary*. Greenwood Publishing Group, 2001.

Franklin. “People of the Feudal System.” *Franklinboe.org*, [www.franklinboe.org/cms/lib/NJ01000817/Centricity/Domain/2449/PeopleoftheFeudalSystem.pdf](http://www.franklinboe.org/cms/lib/NJ01000817/Centricity/Domain/2449/PeopleoftheFeudalSystem.pdf).

Fraser. “Annealing Steel: Annealing Metal.” *Specialty Steel Treating*, Momentum, 2020, [www.sst.net/annealing-steel/](http://www.sst.net/annealing-steel/).

Gascoigne, Bamber. “History of France.” *History of France*, 2001, [www.historyworld.net/wrldhis/PlainTextHistories.asp?ParagraphID=eib](http://www.historyworld.net/wrldhis/PlainTextHistories.asp?ParagraphID=eib).

HTS. “What Is Heat Treating?” *Heat Treating Society*, ASM International, 2020, [www.asminternational.org/web/hts/about/what-is](http://www.asminternational.org/web/hts/about/what-is).

“Kamakura Period.” *Encyclopædia Britannica*, Encyclopædia Britannica, Inc., [www.britannica.com/event/Kamakura-period](http://www.britannica.com/event/Kamakura-period).

Klueh, Ronald., Nelson, A.T., “Optical Micrograph of Tempered Martensite.” *Researchgate*, Sept. 2007, [www.researchgate.net/publication/222267667\\_Ferritic\\_steels\\_for\\_next-generation\\_reactors/figures?lo=1](http://www.researchgate.net/publication/222267667_Ferritic_steels_for_next-generation_reactors/figures?lo=1).

Keen, Maurice. “History - British History in Depth: The Hundred Years War.” *BBC*, BBC, 17 Feb. 2011, [www.bbc.co.uk/history/british/middle\\_ages/hundred\\_years\\_war\\_01.shtml](http://www.bbc.co.uk/history/british/middle_ages/hundred_years_war_01.shtml).

Lambert, Sean. “The Medieval Kingdom of Hungary (1000-1526).” *The Orange Files*, 22 May 2015, [theorangefiles.hu/the-independent-kingdom-of-hungary-1000-1526/](http://theorangefiles.hu/the-independent-kingdom-of-hungary-1000-1526/).

Manning, Scott. “Battle of Bannockburn.” *Encyclopædia Britannica*, Encyclopædia Britannica, Inc., 16 June 2020, [www.britannica.com/event/Battle-of-Bannockburn](http://www.britannica.com/event/Battle-of-Bannockburn).

Material Properties Database. *MakeItFrom.com: Material Properties Database*, 2020, [www.makeitfrom.com/](http://www.makeitfrom.com/).

Medievalist. “Why Was the Longbow so Effective?” *Medievalists.net*, 26 Oct. 2015, [www.medievalists.net/2015/10/why-was-the-longbow-so-effective/](http://www.medievalists.net/2015/10/why-was-the-longbow-so-effective/).

Merriam-Webster. "Murrain." *Merriam-Webster*, Merriam-Webster, 2020, [www.merriam-webster.com/dictionary/murrain](http://www.merriam-webster.com/dictionary/murrain).

Oldfield, Forge. "History of Blacksmithing." *Oldfield Forge*, 28 May 2020, [www.oldfieldforge.co.uk/history-of-blacksmithing/](http://www.oldfieldforge.co.uk/history-of-blacksmithing/).

Parrish, Shane. "Metal Hardening / Metal Quenching / Metal Tempering." *Metlab Heat Treating*, MTI, 2012, [www.metlabheattreat.com/metal-hardening-metal-quenching-metal-tempering.html](http://www.metlabheattreat.com/metal-hardening-metal-quenching-metal-tempering.html).

Ray, Michael. "Avignon Papacy." *Encyclopædia Britannica*, Encyclopædia Britannica, Inc., 15 Oct. 2008, [www.britannica.com/event/Avignon-papacy](http://www.britannica.com/event/Avignon-papacy).

Roach, C. M., and Nicklaus Suino. *Japanese Swords: Cultural Icons of a Nation*. Tuttle, 2014. [www.medievalists.net/2019/06/great-famine/](http://www.medievalists.net/2019/06/great-famine/).

Roberts, Mike. "Plate Armour." *Medieval Chronicles*, 21 Oct. 2019, [www.medievalchronicles.com/medieval-armour/full-plate-armour/](http://www.medievalchronicles.com/medieval-armour/full-plate-armour/).

Rohit, K. "Bainite." *Askmetallurgy*, 16 July 2020, [askmemetallurgy.com/old/bainite-a-microstructural-gem/](http://askmemetallurgy.com/old/bainite-a-microstructural-gem/).

Rosen, William. "10 Things to Know About the Great Famine." *Medievalists.net*, 29 June 2019.

Ryan, Matthew. "People of the Hundred Years' War - Royal Armouries Collections." *Royal Armouries Collections*, Mar. 2016, [collections.royalarmouries.org/hundred-years-war/people.html](http://collections.royalarmouries.org/hundred-years-war/people.html).

Seminary. "Beginning of the Great Western Schism." *Reformation 500*, Concordia Seminary, St. Louis., 30 Jan. 2014, [reformation500.csl.edu/timeline/beginning-of-the-great-western-schism/](http://reformation500.csl.edu/timeline/beginning-of-the-great-western-schism/).

Seven, John. "The Black Death: A Timeline of the Gruesome Pandemic." *History.com*, A&E Television Networks, 16 Apr. 2020, [www.history.com/news/black-death-timeline](http://www.history.com/news/black-death-timeline).

Strongblade. "Medieval Arming Swords." *Medieval Swords - Arming Sword*, [www.strongblade.com/history/medieval-swords.html](http://www.strongblade.com/history/medieval-swords.html).

Sullivan, Missy, et al. "Renaissance." *History.com*, A&E Television Networks, 4 Apr. 2018, [www.history.com/topics/renaissance/renaissance](http://www.history.com/topics/renaissance/renaissance).

Treharne, Reginald Francis. "Edward I." *Encyclopædia Britannica*, Encyclopædia Britannica, Inc., 3 July 2020, [www.britannica.com/biography/Edward-I-king-of-England](http://www.britannica.com/biography/Edward-I-king-of-England).

Vander Voort, George. "Quenched Lath Martensite." *Vac Aero International*, 29 May 2014, [vacaero.com/information-resources/metallurgy-with-george-vander-voort/1391-martensite-and-the-control-of-retained-austenite.html](http://vacaero.com/information-resources/metallurgy-with-george-vander-voort/1391-martensite-and-the-control-of-retained-austenite.html).

Wallace, Brent. "What Is Tamahagane Steel?" *MartialArtSwords.com*, MartialArtSwords.com, 22 Mar. 2017, [www.martialartswords.com/blogs/articles/what-is-tamahagane-steel](http://www.martialartswords.com/blogs/articles/what-is-tamahagane-steel).

Williamson, Mitch. "Mercenaries – During the Middle Ages." *Weapons and Warfare*, 18 Oct. 2017, [weaponsandwarfare.com/2017/10/20/mercenaries-during-the-middle-ages/](http://weaponsandwarfare.com/2017/10/20/mercenaries-during-the-middle-ages/).

Woosnam-Savage, Bob. "Arming Sword - Hundred Years' War." *Royal Armouries Collections*, 2020, [collections.royalarmouries.org/hundred-years-war/arms-and-armour/type/rac-narrative-1252.html](http://collections.royalarmouries.org/hundred-years-war/arms-and-armour/type/rac-narrative-1252.html).

"Yari and Hoko the Japanese Spear." *Yari and Hoko: The Japanese Spear*, [www.ninpo.org/militaryhistory/weapons/yari.html](http://www.ninpo.org/militaryhistory/weapons/yari.html).

Zimmerman, Craig. "Normalizing Heat Treatment." *Bluewater Thermal Solutions*, Backstage CMS, 2020, [bluewaterthermal.com/normalizing-heat-treatment/](http://bluewaterthermal.com/normalizing-heat-treatment/).

"1247 As a Turning Point for the Kamakura Shogunate." *Turning Points in Japanese History*, by Edström Bert, Routledge, 2016, pp. 25–34.

### Figures:

Armstrong, Ian. "Antique Japanese Naginata." *Wikipedia*, 12 July 2008, [commons.wikimedia.org/wiki/File:Antique\\_Japanese\\_naginata\\_blade.jpg](https://commons.wikimedia.org/wiki/File:Antique_Japanese_naginata_blade.jpg).

Artist, Unknown. "Battle of Crecy." *Ancient History Encyclopedia*, 2020, [www.ancient.eu/Hundred\\_Years'\\_War/](http://www.ancient.eu/Hundred_Years'_War/).

Bachmann. *Knightly Sword*, Wikia.org, July 2020, [military.wikia.org/wiki/Knightly\\_sword](http://military.wikia.org/wiki/Knightly_sword).

Blacksmithing, CJForge. "Man & Machine." *Facebook*, 8 Dec. 2014, [www.facebook.com/CJForgeBlacksmith/photos/857526710965140](https://www.facebook.com/CJForgeBlacksmith/photos/857526710965140).

Collins, Matt. "Satan in the Last Judgement." *Khan Academy*, 2015, [www.khanacademy.org/humanities/renaissance-reformation/late-gothic-italy/florence-late-gothic/a/dantes-divine-comedy-in-late-medieval-and-early-renaissance-art](http://www.khanacademy.org/humanities/renaissance-reformation/late-gothic-italy/florence-late-gothic/a/dantes-divine-comedy-in-late-medieval-and-early-renaissance-art).

Cram, James. "English Longbow." *Wikipedia*, 25 Aug. 2007, [en.wikipedia.org/wiki/English\\_longbow](http://en.wikipedia.org/wiki/English_longbow)

DePropsero, Dan, and Jackie DeProspero. "Japanese Archery." *Kyudo*, 2 Apr. 2012, [www.kyudo.com/kyudo-e5.html](http://www.kyudo.com/kyudo-e5.html).

Dhafer, Noor. "Photomicrograph of a 1.4 wt% C Steel Having a Microstructure Consisting of a White Proeutectoid Cementite Network Surrounding the Pearlite Colonies." *ResearchGate*, July 2019, [www.researchgate.net/figure/Photomicrograph-of-a-14-wt-C-steel-having-a-microstructure-consisting-of-a-white\\_fig82\\_334465619](https://www.researchgate.net/figure/Photomicrograph-of-a-14-wt-C-steel-having-a-microstructure-consisting-of-a-white_fig82_334465619).

Draeger, Donn F. (1973) *Classical Bujutsu - The Martial Arts and Ways of Japan*. Weather Hill. Page 71.

Evelyn, Luna. "Iron-Carbon Phase Diagram." *General Wiring Diagram*, 28 Mar. 2019, [galvinconanstuart.blogspot.com/2019/03/iron-carbide-diagram.html](http://galvinconanstuart.blogspot.com/2019/03/iron-carbide-diagram.html).

Foll, H. "Structure of Hypoeutectoid Steel." *How Do You like Your Mix?* 2005, [www.tf.uni-kiel.de/matwis/amat/iss/kap\\_7/backbone/r7\\_2\\_1.html](http://www.tf.uni-kiel.de/matwis/amat/iss/kap_7/backbone/r7_2_1.html).

Forman, Werner. "The Triumph of Death." *History.com*, A&E Television Networks, [www.history.com/news/black-death-timeline](http://www.history.com/news/black-death-timeline).

Hamada, Shigeru, et al. "Microstructure of the Pearlite Steel." *ResearchGate*, Dec. 2011, [www.researchgate.net/figure/Microstructure-of-the-pearlite-steel-SEM-picture\\_fig2\\_241123983](https://www.researchgate.net/figure/Microstructure-of-the-pearlite-steel-SEM-picture_fig2_241123983)

JNTO, Japan. "Hot Tamahagane." *Japan Endless Discovery*, 2020, [www.japan.travel/en/au/story/how-traditional-samurai-sword-made/](http://www.japan.travel/en/au/story/how-traditional-samurai-sword-made/).

Kuniyoshi, Utogawa. "Kozaemon Hisamitsu." *Wikipedia*, 30 Aug. 2011, [commons.wikimedia.org/wiki/File:Kozaemon\\_Hisamitsu\\_mounted\\_and\\_armored,\\_but\\_bareheaded,\\_on\\_his\\_galloping\\_steed.jpg](https://commons.wikimedia.org/wiki/File:Kozaemon_Hisamitsu_mounted_and_armored,_but_bareheaded,_on_his_galloping_steed.jpg).

Le Tavernier, Jean. "Le Siege De Constantinople." *Wikipedia*, 16 Feb. 2020, [en.wikipedia.org/wiki/Fall\\_of\\_Constantinople](http://en.wikipedia.org/wiki/Fall_of_Constantinople)

Longueville, Olivia. "Charles VIII of France." *Olivialongueville.com*, 30 June 2020, [olivialongueville.com/2020/06/30/charles-viii-of-france-accidental-death-after-a-momentary-glory-in-italy/](http://olivialongueville.com/2020/06/30/charles-viii-of-france-accidental-death-after-a-momentary-glory-in-italy/).

Loulas, Edna. "Tamahagane." *Wikipedia*, 30 Mar. 2008, [commons.wikimedia.org/wiki/File:Tamahagane.jpg](https://commons.wikimedia.org/wiki/File:Tamahagane.jpg).

Manesse, Codex. "Codex Manesse Hartmann Von Aue." *Wikipedia*, 12 Mar. 2012, commons.wikimedia.org/wiki/File: Codex\_Manesse\_Hartmann\_von\_Aue.jpg.

Masatsune, Unknown. "Tachi Sword." *Wikipedia*, 16 Dec. 2020, en.wikipedia.org/wiki/Tachi

Mohr, Jens. "Armborst." *Wikipedia*, 25 May 2016, commons.wikimedia.org/wiki/File: Armborst, 1500-tal\_-\_Livrustkammaren\_-\_106745.tif.

Moyer, Jeff. *Simplifaster*, Sept. 2018, simplifaster.com/articles/hammer-paradox-motor-pathways/.

Missaglia, Antonio. "Italian Suit of Armor with Sallet." *Wikipedia*, 2012, en.wikipedia.org/wiki/Plate\_armour#/media/File: Italian\_-\_Sallet\_-\_Walters\_51580.jpg.

Oakeshott, Ewart. "Arming Sword Parts." *Sword Site*, 6 Aug. 2013, swordsite.wordpress.com/tag/arming-sword/.

Parrott-Sheffer, Chelsey. "Blast Furnace." *BC909*, 2020, bc909.com/technology/blast-furnace.

Petersen, Jan. "Rare Viking Sword." *Bonhams*, 29 June 2005, www.bonhams.com/auctions/13103/lot/2410/.

Sanzio, Raphael. "School of Athens." *The Renaissance*, 2013, www.tampapix.com/renaissance.htm.

Sauber, Wolfgang. "Fornsalen -Invasion 1361-." *Wikipedia*, Aug. 2007, https://commons.wikimedia.org/wiki/Category:Valdemar\_Atterdag\_brandskattar\_Visby

SBG, Store. "Samurai Sword Terminology." *Sword Buyers Guide*, 2005, www.sword-buyers-guide.com/samurai-sword-terminology.html.

Sittow, Michael. "Enrique VII De Inglaterra." *Wikipedia*, 3 Mar. 2019, en.wikipedia.org/wiki/1500s\_(decade)

Suttles, Sonny. "Bristol Medieval Arming Sword ." *Valiant Armoury*, Apr. 2017, www.valiant-armoury.com/products/va-403-craftsman-series-the-bristol-medieval-arming-sword.

Swords, True. "Katana Parts." *Trueswords*, 2020, www.trueswords.com/Katana-Parts-Info.

Takanobu, Fujiwara. "Minamoto No Yoritomo." *Wikipedia*, 20 Dec. 2016, commons.wikimedia.org/wiki/File:Minamoto\_no\_Yoritomo.jpg.

Tatsuo, Inoue. "Cross Section of Tatara Furnace." *Science of Tatara and Japanese Sword*, 2004, www.jsme.or.jp/tsd/ICBTT/conference02/TatsuoINOUE.html.

Tokyo, National. "Domaru." *Wikipedia*, 10 July 2020, en.wikipedia.org/wiki/Japanese\_armour

Unknown. "Avignon Pope Palace." *History Extra*, 8 Sept. 2019, www.historyextra.com/period/medieval/why-papacy-pope-residence-move-avignon-france-14th-century/.

Universe, Weapons. "Medieval Polearms." *Weapons Universe*, 2015, www.weapons-universe.com/Swords/Medieval\_Polearms.shtml.

Velling, Andreas. "Iron-Carbon Phase Diagram ." *Fractory*, 3 Oct. 2020, fractory.com/iron-carbon-phase-diagram/.