

Benchmarking the Uses of Smart Technology to Increase Mobility of Fire Engines in Beijing and Wuhan



Figure 1 Chinese Fire Engine (Wang, X. and Luo, J., 2015).

Beijing IQP: Smart Fire Trucks



Robert James Bellitto

Conroy Lauren

Ruyue Wang

Advisor: Jianyu Liang

Sponsor: WPI-Tsinghua Center for Global Public Safety

Authorship

Robert James Bellitto, Lauren Conroy and Ruyue Wang all contributed to the research and writing of this report. All members were involved in the following aspects of the project:

- Research pertaining to the Introduction & Background
- Writing of the Introduction, Background, Methodology, Results, Recommendations and Conclusion.
- Editing each section

Abstract

Fire engines in China are facing challenges and limitations when driving to and while attempting to extinguish fires. These challenges and limitations are a direct result of the progressive urban development of cities and the outdated technology and framework of the fire engines currently in use. With guidance from the Tsinghua-WPI Center for Global Public Safety, this research project analyses current fire engines technology and explores smart technology options that can benefit fire engines in China by making them more adaptable to the changing urban landscape.

Table Of Contents

1.0 Introduction	7
2.0 Background	10
2.1 Impacts of Urbanization on the Effectiveness of Fire Engines	10
2.1.1 Fires in Urban Environments	10
2.1.2 Effects of Urban Sprawl on Fire Engines in Beijing and Wuhan	12
2.2 Capability of Current Chinese Fire Engines	15
2.2.1 Classifications of Fire Engines	16
2.2.2 Urban Fire Hose Technology	17
2.2.3 Safety Tolerances and Controls	19
2.3 Smart Technology and its Uses in Urban Fire Engines	21
2.3.2 GS-911CAD	23
2.3.3 Smart Fire Hose Technology	24
2.3.4 Fire Engine Auxiliary Power Units (APU's)	25
2.3.5 Advanced Aerial Control Systems (AACCS)	26
2.3.6 RFID Tagging and "Mobile Warehouses"	27
2.3.7 Radio Communications	28
3.0 Methodology	29
3.1 Identifying Standard Technical Capabilities of an Urban Response Vehicle	29
3.1.1 Benchmarking of American Fire Engines	29
3.1.2 Benchmarking of Fire Engines in Beijing and Wuhan	31
3.2 Compiling Information on Smart Technologies	31
3.2.1 Researching Developing Technologies in China	32
3.2.2 Comparative Analysis of Potential Improvements to Chinese Fire Engines	32
3.3 Recommending Specific Smart Technologies	34
3.3.1 Compiling Potential Technologies	34
3.3.2 Determining Technology that Will Benefit Urban Fire Departments	35
4.0 Results	36
4.1 US Results	36
4.1.1 Distribution of Incident Class	36
4.1.2 Currently Implemented and Desired Technologies	37
4.2 Chinese Results	38
4.2.1 Social Infrastructures	40
4.2.2 Physical Infrastructure	44
4.2.3 Budget Limitations on Technological Investment	45
4.2.4 Network Restrictions	46
4.2.5 Inconsistent Communication	47
5.0 Recommendations	48
5.1 Currently Implementable Recommendations	49
5.1.1 Fire Engine Auxiliary Power Units (APU's)	49
5.1.2 Advanced Aerial Control Systems (AACCS)	50
5.1.3 Wireless Piezometer	51

5.1.4 Emergency Radio Communications	52
5.2 Future Recommendations	54
5.2.1 GS-911 CAD	54
6.0 Conclusion	56
7.0 Works Cited	57
8.0 Appendix	62
8.1 American Survey	62
8.2 Chinese Survey	63

Table Of Figures

Figure 1 Chinese Fire Engine (Wang, X. and Luo, J., 2015).....	0
Figure 2 Map of Mainland China (China Discovery, 2018).....	13
Figure 3 Map of Beijing's Inner City (Beijing Statistical Yearbook, 2016).....	13
Figure 4 Map of Active and Proposed Fire Stations in Beijing (Beijing Municipal Bureau of Urban Planning, 2009).....	14
Figure 5 Fire Hose Technology (Gea, Yong-xing and Yao-zong, 2011).....	17
Figure 6 Example of Simple Switches.....	20
Figure 7 Aerial Apparatus and Outrigger (Fire Apparatus & Emergency Equipment, 2012).....	20
Figure 8 LCD Panel (Smeal, 2015).....	25
Figure 9 Smeal™ SG-09 (Smeal, 2013).....	25
Figure 10 Onboard Receiver FSE-727 (E-ONE, 2017).....	26
Figure 11 Advanced Aerial Control System (AACS) (E-ONE, 2017).....	26
Figure 12 Tsinghua Firefighter Breakdown.....	38
Figure 13 Wuhan Emergency Personnel Breakdown.....	39
Figure 14 Data from Interviews	40
Figure 15 Hierarchy of Chinese Firefighters	42
Figure 16 Hierarchy of Chinese Lieutenants	43
Figure 17 Chinese Fire Department Operational Procedures	43
Figure 18 Prevalent Incident Breakdown	44
Figure 19 Diagrammatic Recommendations.....	48
Figure 20 Auxiliary Power Unit.....	50
Figure 21 TETRA Diagram (David Jordan, 2007).....	53



Table Of Tables



Table 1 Classification of Fire Engines	16
Table 2 Smart Technologies	21
Table 3 Types of Fire Engines	41
Table 4 Surveyed Future Needs	42

1.0 Introduction

Firefighting, and more specifically the operation and effectiveness of fire engines in urban environments pose many challenges based on a multitude of qualities not seen in any other setting. The substantial presence of automobile traffic and construction efforts induce restrictions on the navigation and expediency of fire engines when attempting to reach an active incident site. Additionally, the threat of fires forming in high rise structures generate a multitude of pre-existing dangers ranging from the spreading of fires between structures to the ability of hose equipped fire engines to reach highly elevated flames in tall stories (Kolesar, 1975).

This project focuses on researching and combating these issues specifically within the cities of Beijing and Wuhan, China. Challenges such as these pose a major concern for the Chinese people due to increasing fire incident rates in recent years as well as the unique urban setting in Chinese cities. Domestically sourced studies from Beijing dating back to the 1970's describe a unique relationship in China between the nation's recent socioeconomic development and the proliferation of fire incidents. While developed nations commonly experience decreases in incident rates as a result of economic growth and urbanization, their Chinese counterparts have experienced an opposite effect; in which there is a positively proportional relationship between these two variables (Lizhong, 2003). The threat posed by this social phenomenon is accompanied by increasing risk due to urban growth in the physical sense as well. The overall urban land area, known as total urban extent, displays an increase in Beijing and Wuhan of 6.7% and 10.9% respectively from 1999 to 2013. Comparatively, the urban extent of New York City has grown only 0.2% from 2000 to 2011 (Atlas of Urban Expansion, n.d.). There are significant development of road systems, high rise structures and public works projects in both Beijing and

Wuhan. The fast growth generates altered traffic patterns and structural fire risks which adversely impede the operation of fire engines.

Such statistics and demands have prompted the action of several fire research centers in conjunction with the Chinese Ministry of Public Security, a government bureau under the central government responsible for the maintenance of public safety. Research and fabrication of new fire suppression apparatus by government coalitions such as these have helped to advance the capability of local firefighting methods and techniques for fire engines. Examples range from adjustable nozzles meant to propel water out of on-board hoses at extremely high pressures to more chemical solutions such as specialized extinguishing foams which can adhere to surfaces. Our sponsor, the WPI-Tsinghua Center for Global Public Safety (CGPS), is one such organization that has dedicated their resources to the research and creation of similar, effective counter-measures. Integrating smart technologies on local fire engines is one of the research areas pursued by CGPS. Smart technologies are devices capable of analyzing data to take actions and could supplant many of the time-consuming activities firefighters face when preparing an engine for operation.

Although our sponsor's efforts helped to bring greater attention to fire risks facing Chinese cities to the purview of the public, they also recognized the need to seek expertise globally, as well as generate a comprehensive means of attracting investment in their program. Our project has filled this gap by creating a report analyzing the potential implementation of smart technologies in Beijing and Wuhan's fire engines that will assist addressing the problem of operating fire engines in urban settings. To reach this goal, we established and executed a methodology comprised of the following three methods: to identify standard technical capabilities of an urban response vehicle, compile information on relevant smart technologies

and to collate this research into supported recommendations for specific smart technologies. Attention and consideration to discernable, individual necessities established by our research contacts from Tsinghua University, the Chinese People's Armed Police Academy (CPAPFA) and the Wuhan Fire Department helped to organize these recommended smart technologies into currently implementable solutions as well as those holding future prospect in the case of unforeseen development. This study provides Chinese cities such as Beijing and Wuhan with a thorough resource to pull from to improve the effectiveness of fire fighting through establishing benefits of individual technologies and their application to local fire engines.

2.0 Background

The following synopsis of municipal data and other information from relevant sources outlines the everyday concerns and challenges faced through the operation of fire engines in urban environments. These challenges are illustrated as they apply both in the general sense as well as specifically within our scope of the Chinese cities of Beijing and Wuhan. This is followed by a detailed overview of the potential solutions present through the integration of smart technologies, including specific examples of prevailing smart fire technologies.

2.1 Impacts of Urbanization on the Effectiveness of Fire Engines

The operation of fire engines in urban environments is a universal challenge which faces cities around the world. This unique setting brings with it a number of common challenges that each take on particular traits when observed in individual locations. This section will provide an overview on some of these prevailing, global obstacles and the more exclusive problems which can be observed in our project locations, the Chinese cities of Beijing and Wuhan.

2.1.1 Fires in Urban Environments

The issues formed as a result of the utilization of fire engines in urban environments form comprehensively acknowledged limitations. Traffic generated as a result of urban commuters greatly hinders the ability of fire engines to swiftly and efficiently reach incident areas. A study on the response times of fire engines operated by the New York Fire Department establishes that during the high traffic periods of morning rush hour the average velocity of fire engines drop by 20% (Kolesar, 1975). This drawback only escalates as a result of the fast spreading rate of fires within urban sectors due to the presence of high-rise structures. Buildings such as these have

many staircases, elevator shafts, pipe shafts and other vertical ducts. If fire separation, the minimum required distance between combustible materials and other spreading routes, is not arranged reasonably they will they will become passages to spread fire comparable to chimneys. This is especially true in superior hotels, libraries, and office buildings due to a large presence of combustible materials. Once a high-rise building with the height of 100 m catches fire, smoke will diffuse to the top floor through the vertical shafts in 30 seconds, and its velocity is more than 10 times that in the horizontal direction. Data taken from the New York Fire Department states that the average response time of a fire engine to a structural fire in New York City is 3.33 minutes (NYC Analytics, 2018). Considering it only takes carbon gases 30 seconds to travel 100 m, the fire already poses a significant threat by the time emergency responders arrive on the scene. For reference, fires following the famous Hanshin, Japan Earthquake which took place in 1995 spread over an area of 0.65 sq. km or roughly 100 city blocks before it was extinguished (Himoto, 2010).

Despite the harsh and demanding qualities urban settings increasingly produce as they develop both through road networks and vertical elevations, the world has acknowledged a downward trend of overall incidents with the progress of socioeconomic development. Evidencing this, the U.S. Fire Administration records an overall decrease of 25.8% of fires per one million people from 2002 to 2011 (U.S. Fire Administration, 2018). Meanwhile, urban population growth in the United States has continued to progress, increasing at an annual rate of 0.91% in the same time frame according to the World Bank (The World Bank, 2018). Similar data can be seen in developed nations around the world, however this state of improvement is not as consistent among currently developing nations. Our project's focus in China, the cities of

Beijing and Wuhan, are two such examples of urban sites which have seen a positively proportional rate of fire incidents to their respective trends of expansion (Lizhong, 2003).

2.1.2 Effects of Urban Sprawl on Fire Engines in Beijing and Wuhan

The capital city of Beijing, as indicated by the star in **Figure 2**, sits in the northern half of the country; with Wuhan, bolded in red font, sitting 1,158 km south in the Hubei Province. These locations, along with numerous other Chinese urban centers, represent a majority of the world's fastest growing cities. The city of Beijing records an annual growth rate of 5.2% from 1999 to 2013; increasing the overall population from 9,869,844 to 20,669,397 (Atlas of Urban Expansion, n.d.). Wuhan produces similar data, showing an annual growth rate of 4.3% from 2000 to 2013 (Atlas of Urban Expansion, n.d.). The high growth rate of the population precipitates their respective cities' increase of road networks and structures. Beijing operates on a network of outwardly expanding ring roads which divide the city's land mass into rounded sections, numbers two through four being outlined by the bolded olive borders in **Figure 3**. Completion of the G95 expressway in 2016 marks the addition of Beijing's seventh ring in total, stretching nearly 1,000 kilometers in length and expanding the city to a land area of 16,810 sq. km (Beijing's new highways connect area twice the size of New York, 2016). These cities' upward momentum have also pushed them to retain some of the highest numbers of buildings taller than 150 m on a global scale. This list places Beijing at number 37, and Wuhan at number 22 when compared to the rest of the world's major cities (The Skyscraper Center, 2018).

Beijing's rapid proliferation of road networks and construction efforts has begun to show tangible effects on general city operations; and the appearance of a phenomenon known as the urban sprawl. As growing road networks stretch the city's boundaries outward, a sort of vacuum effect can be observed through the movement of traffic. Traffic density is typically highest in the central or downtown areas of municipal zones. For example, the New York State Traffic Data Viewer records the highest concentration of traffic to lie south of Central Park in the downtown area (NYSDOT, 2018) . However, GPS data from 2016 detailing Beijing's taxi routes indicate



Figure 2 Map of Mainland China (China Discovery, 2018).

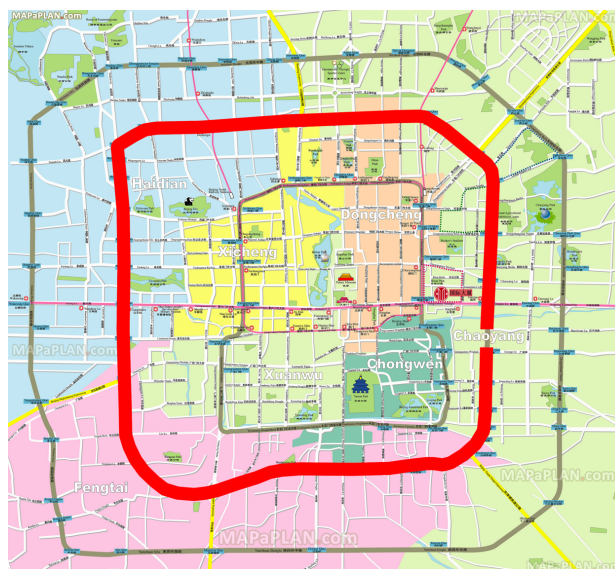

Figure 3 Map of Beijing's Inner City (Beijing Statistical Yearbook, 2016).

the Third Ring to contain the highest traffic density with varying hotspots appearing even further out into the city limits. What this shows is a massive, outward relocation of Beijing's highest points of traffic congestion and decentralization of city function (Zhao, Li, & Liang, 2016). Traffic in the Third Ring forms what is essentially a wall, bolded red in **Figure 3**, dividing the interior districts of which represent the largest population density and the greatest concentration of high rise office buildings from the extension area representing the main residential sector (Beijing Statistical Yearbook, 2016). This residential sector within the extension area contains

the highest percentage of fire incidents at 39%. An area of high fire incident rates necessitates the presence of immediately accessible departments in order for fire engines to adequately and swiftly respond with minimal collateral damage (Chi, 2003). However, maps detailing the placement of both active and proposed development sites for Beijing fire departments, denoted by blue and red markers in **Figure 4** respectively, reveal a majority of stations to lie within the central districts of the city. The outline of the Third Ring has been superimposed onto this map for reference. A majority of fire incidents which take place in Beijing not only lie beyond the highest concentration of established department locations but are divided by the decentralized wall of traffic which has flourished as a result of urban sprawl. The capability of fire engines to reach these high-risk areas is greatly diminished due to this phenomenon.

The city of Wuhan is showing similarly impactful trends of infrastructural development and urban sprawl. 2014 saw nine separate subway lines being developed simultaneously within Wuhan (China's Urban Nightmare: Gridlock, 2014). To make room for these massive projects city officials condense the existing road systems, sometimes reducing roads as wide as four lanes to only two (China's Urban Nightmare: Gridlock, 2014). Currently, the average road width in

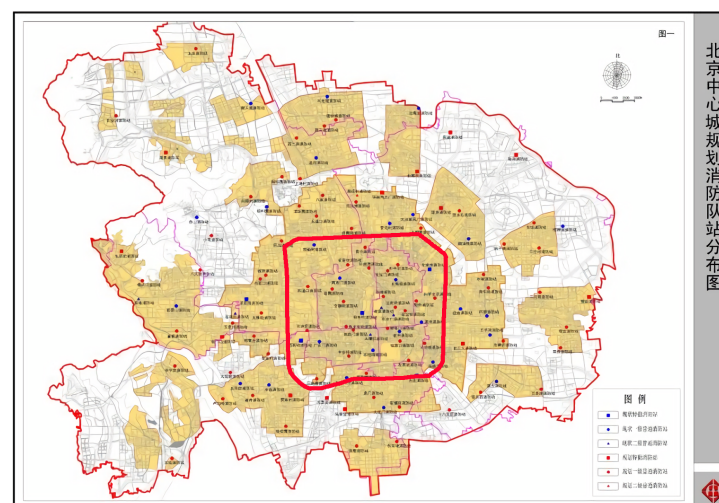

Figure 4 Map of Active and Proposed Fire Stations in Beijing (Beijing Municipal Bureau of Urban Planning, 2009)

Wuhan is measured to be 6.28 m or 20 ft (Atlas of Urban Expansion, 2014). This value is the same as the minimum road width required for average fire engine operation but does not take into account the presence of automobiles or other likely obstacles (Botetourt County, VA, n.d.). Essentially, the roads in Wuhan are not wide enough to safely facilitate the use of fire engines.

2.2 Capability of Current Chinese Fire Engines

The growth of China in terms of population and urban development has directly cause an increase in fires throughout the country. Within the years of 1998 to 2002, the number of fire incidents has increased from 142,326 to 258,315, which is a very large jump from 1996 which had only 15,000 fires (Wang, Lu and Li, 2005). This large jump is drawing the attention of the nation and even the world to this problem including our sponsor, Tsinghua University, who recently formed the WPI-Tsinghua Center for Global Public Safety (WPI, n.d.). The technical evolution of firetrucks in China is the direct result of the change urban expansion. As the cities have become more populated, the streets have become narrower and the buildings have become taller making the physical design of current fire engines smaller in frame as well as requiring fire engines to reach higher buildings.

2.2.1 Classifications of Fire Engines

Based on the weight of chassis		Based on Usage	
Fire Engine Name	Weight of Chassis(in kg)	Fire Engine Name	Usage
Light Fire Engine	500 - 5000	Emergency Rescue Fire Engine	Commonly used fire engine
Medium Fire Engine	5000 - 8000	Urban Main fire Engine	Mainly used fire engine in cities
Heavy Fire Engine	>8000	Water/Foam Tanker Fire Engine	To store water and foam
		Aerial Tower Fire Engine	To deliver water to high rise buildings
		Aerial Platform Fire Engine	To help fire fighters reach high buildings
		Fume Exhauster Fire Engine	To exhaust the smoke in the fire spot

Table 1 Classification of Fire Engines

As stated in section 2.1, China's urban development limits fire engines in terms of maneuverability through narrow spaces and streets with main roads being 6.28 m and the minimum road width of large water tank fire engines widths being 6.3 m. The main factor to increase this desired maneuverability is by having varying chassis carry capacities. Numerous examples are organized by weight and usage in **Table 1**. Chinese fire engines have three types based on the chassis carrying capacity where each type is more customized for the city or town they are serving. These chassis are separated into light, medium and heavy carrying capacities which mainly refers to how much equipment the fire engines can hold. Light fire engines ranges from 500 to 5000 kilograms, medium fire engines ranges from 5000 to 8000 kilograms and heavy fire engines is over 8000 kilograms (Jun Cheng, 2012). When going to fires that are smaller and are easily managed with a dry powder extinguisher and the roads are narrow, the light fire engines are essential for China since they are easily maneuverable due to their small footprint. Medium fire engines have water tanks and ladders for fires that are not extinguishable by just water or dry powder. Heavy duty fire engines are able to handle fires in large high rises as well as fires that cannot be easily extinguished with foam, powder or water. In China, the

average ratio of light, medium, and heavy fire engines in China is 2:5:3 versus the average ration in foreign countries which is 3:4:3. This displays that China has an inadequate amount of light fire engines making extinguishing fires in the crowded urban sprawls of large cities such as Beijing very difficult.

2.2.2 Urban Fire Hose Technology



Turbojet Fire Engine



Fine Mist Fire Engine



Compressed air-A/B type foam Fire Engine



Aerosol Fire Engine



Compound Spraying Fire Suppressant



Positive Ventilating Engine

Figure 5 Fire Hose Technology (Gea, Yong-xing and Yao-zong, 2011).

The urban planning and urban sprawl of China has also led to the increase in buildings and the heights of these buildings. The Chinese have several fire engines, examples of which are outlined in **Figure 5**, with one of the most current trucks feature a nozzle that has a manually

adjustable power output ranging from .5 kW to 50000 kW, adjustable speed output and a high ratio of power to weight. These adjustable settings make it possible for larger fire engines that cannot drive through the smaller roads of large cities extinguish fires that are as far away as 100 meters away and stretch upwards of 30.48 meters (Wang and Luo, n.d.)(Fireengineering.com, 2001). They can also use the higher power nozzles to extinguish fires that are in the copious high rises that are packed across the city. For spraying technique alone in China, there are 6 main groups of fire engines that specialize for various types of fires. The turbojet fire engines specialize in putting out large fires in airports, high rises, storage facilities. It sprays a fine-gas mist or a gas-extinguishing foam that has a high energy to easily penetrate through the flames and cool and blow them away. Fine mist fire engines rely on a fine water-based mist that is sprayed at a large speed to absorb toxic gases, cool the fire and quickly dissipate the smoke. This truck is usually seen at the sight of housing, hotel and hospital fires. Fires that involve oil or petrochemicals, which are chemicals obtained from petroleum or natural gas, call upon the compressed air-A/B type foam fire engines. These trucks spray a special chemical-based foam, which adheres to the building on fire to quickly extinguish the fire. The aerosol fire engines use an extremely fine powder which expands into an aerosol to extinguish fires that are rapidly spreading such as older constructed buildings and high-rise buildings. The final two trucks are more ubiquitous and can be used for different types of fires. Compound spraying fire engines are used in A, B and C fire types, and sprays a three-phase system unlike the previous four fire engines that are based on two-phase systems. Class A fires cover combustible materials such as wood, paper and fabric, class b fires cover flammable liquids and class C covers flammable gases. This fire engines simultaneously sprays compressed gas, water and extremely fine powder. The gas provides a build-up of energy for the water a powder, the powder incautiously

extinguishes the fire and the water prevents the fire from reigniting. Lastly, the high power positive ventilating truck is essentially a giant fan that introduces a fine water mist to a fire (Gea, Yong-xing and Yao-zong, 2011). These hose technologies allow for the extinguishing of fires in China's urban sprawl and ever increasing urban development.

2.2.3 Safety Tolerances and Controls

The substantial elevations which necessitate the use of these specialized hoses are reached through the installation of systems known as aerial apparatus. Aerials are high powered, motor-controlled levers which are used to raise tools or platforms to areas out of reach for ground-based fire rescue teams. In urban environments such as Beijing and Wuhan which have placed globally for their concentrations of buildings taller than 150 meters, the swift and accurate deployment of these resources become essential. However, safe operation of aerials is no simple task and could potentially compromise the stability of an idle engine when moved to an area outside of the vehicles zone of support. The vehicle's zone is expanded with stabilizers known as outriggers; which are mechanical beams extending out from the sides of a fire engine and accompany the use of aerial apparatus to ensure the vehicle does not tip and remains stabilized (Fire Apparatus & Emergency Equipment, 2012). Both systems, which are outlined in **Figure 7**, can still potentially suffer due to human error despite their effectiveness. During interviews with cadets of the Chinese People's Armed Police Forces Academy (CPAPFA), the nation's foremost institute in fire research, they were quick to identify the burden placed on the simple command structure's integrity while operating in an active incident. The students explained this structure as having two points of focus between a controller stationed at the physical panel and a man of higher rank on the ground responsible for giving instructions to the controller while observing

the surrounding environment. Ill-informed instructions from the man on the ground, or misheard communications by the controller could result in destabilization.



Figure 7 Aerial Apparatus and Outrigger (Fire Apparatus & Emergency Equipment, 2012).



Figure 6 Example of Simple Switches

In response to this, Chinese fire services have installed electrical safety tolerances to these fallible systems to reduce risks. These simple switches, pictured in **Figure 6** at the CPAPFA's engine garage, are pressed when the aerial tips too far in the axis which it is installed. As a result, the control system will receive an automatic series of inputs which move the apparatus to a pre-determined safe zone. Even with the threat of unsafe aerial movements reduced, such a stagnant system will greatly impose on the expediency of recovery to the devices required placement. A system unable to learn based on individual incidents will be unable to adapt to an active scenario, bringing with it the new issue of balancing safety and timeliness.

2.3 Smart Technology and its Uses in Urban Fire Engines

Geographic Information System (GIS) & Related Technologies	GS-911CAD	Smart Fire Hose Technology	Fire Engine Auxiliary Power Units (APU's)	Advanced Aerial Control Systems (AACS)	Radio Frequency Identification (RFID) Tagging and "Mobile Warehouses"	Radio Communications
<ul style="list-style-type: none"> • TransCAD: Transportation planning software • PARAMICS: Collections of software tools • LINDO: Linear programming optimization software 	<ul style="list-style-type: none"> • Aggregates data from multiple sources to give information such as gas level and most direct route to fire 	<ul style="list-style-type: none"> • Smart Flow Nozzle Wireless Piezometer: provides feedback for the fire trucks about one or more selected operating parameters e.g.: real-time water pressure 	<ul style="list-style-type: none"> • When idling between calls, it supplies energy for onboard appliances without using fuel 	<ul style="list-style-type: none"> • Stabilized outrigger and aerial control • Connects to a receiver on board 	<ul style="list-style-type: none"> • Monitors and selects equipment that can be supplied for a call by tracking RFID tags. 	<ul style="list-style-type: none"> • New radios that allow for prioritizing transmissions based on rank of firefighter using radio.

Table 2 Smart Technologies

Smart technology is defined as any form of technology that has the ability to sense changes in their surroundings and execute measures to enhance their functionality under new circumstances (Bullough, Worden and Haywood, 2003). Smart fire engine technology is simply smart technology that is related to fire protection which is integrated into a fire engine. It is commonly used to improve the performance of man-operated systems. In the case of fire engines, this means that components like the engine mounted hoses can detect changes in pressure and modify itself to meet the current demands. **Table 2** outlined several examples of such technologies, which are expanded upon in the following sections.

2.3.1 Use of GIS and Its Related Technologies to Optimize Fire Engine Response

A Geographic Information System (GIS) is a computer system designed to capture, store, analyze, manage and display all kinds of spatial data. The usage of GIS has increased over the past decades. GIS has evolved into a system with more advanced functions of modeling and analyzing than its initial data storage and mapping. To better equip GIS for fire responding strategy, many different technologies and systems have been combined with GIS. These include

Intelligent Transportation System (ITS) (TransCAD GIS), Traffic simulation system (PARAMICS Microsimulation), and optimization engine (LINDO system) (Bo Huang and Xiaohong Pan, 2006).

TransCAD is a transportation planning software that includes extensions for transportation on a GIS engine in order to optimize the navigation efficiency of fire engines. TransCAD has a graphical user interface, transportation network data functions, and routing system for modeling and analyzing transportation related problems. It can generate the optimal routes for firefighters based on the real-time traffic situations.

PARAMICS is a collection of software tools that can model the movement and performance of individual fire engines on urban and highway roads. Since all new technologies require intense amount of testing before safely applying to real world, a simulation system is required. PARAMICS Microsimulation can simulate real world traffic with a 3D real-time display system. Also, since testing is all done through software, test and revise process could be performed as fast as the computer can run the simulation.

LINDO is a linear programming optimization software to determine the optimal problems of fire engines and output the results into TransCAD GIS for further analysis. Since the GIS itself not capable of computations, LINDO system is equipped as an optimization engine to handle mathematical programming of different kinds of computation and optimization including linear, nonlinear and quadratic programming.

The conventional dispatching approach uses local proximity, which is to distribute the fire engines based on the shortest distance to the location of the fire spot. The local proximity is based on the interviews and information from the related fire department and firefighter. Compared with the conventional strategy, GIS together with its combine technologies

significantly improve the effectiveness of dispatch and navigation of the fire engines based on the research. (Bo Huang and Xiaohong Pan, 2006)

2.3.2 GS-911CAD

GS-911CAD is a smart command terminal physically attached to a fire engine's control center to enhance efficiency and safety in the case of an active incident. This software offers many options such as providing the current levels of gas, water or specialized extinguishing chemical within the fire engine through several sensors. Similarly, it can also calculate the estimated time left that the fire engine can fully function base on those levels specified. In addition, the GS-911CAD can recognize the real-time navigation of traffic routes as well as give the most efficient route to reach the incident site quickly and easily. Furthermore, GS-911CAD can scan the firefighters and equipment in a certain fire engine and relay that information to the command center responsible for acquiring situation details. For example, when a rescue or aid deployment has been resolved, the GS-911CAD will automatically scan the firefighters and equipment in the fire engine to report whether there are personnel or equipment missing. Furthermore, the command center could provide combat maps to the GS-911CAD terminal at the fire engine, sharing all information and essential situation reports for firefighters being deployed to the scene. This map includes information about the time of arrival for reinforcements and locations of suitable water sources nearby which improves the ability of communication between each fire engine during collaboration.

Although these GPS based applications are very beneficial to firefighters and may seem like a versatile solution, the application of these types of software is currently not feasible. Many fire departments and other government agencies exclusively use isolated platforms to hold data and information leaving options such as GS-911 CAD, which compiles and relies upon input

from public GPS systems and databases, unsuited for the current political climate. Currently, the GPS networks of most fire departments are lacking and in need of constant updates despite the availability of expediently refreshed, public systems. This need is only amplified in cities such as Beijing and Wuhan due to their substantial rates of expansion. With outdated maps or information, local departments could deploy resources and personnel into the same situation with inconsistent guidance generating increased response times and further damage to the city or civilian safety. Until this is resolved, the recommendations we make as a team will be limited to smart technologies which are non-reliant on such inapplicable learning networks.

2.3.3 Smart Fire Hose Technology

When putting out the fires, the firefighters need to determine what pump pressure (pound per square inch, or PSI) is necessary to deliver to a certain nozzle. Normally, PSI is calculated by numerous factors such as diameter and length of hose, nozzle type, elevation, and flow volume of water. However, firefighters usually have less than optimal time to do so. In order to improve the effectiveness and avoid the dangerous situations caused by inappropriate water pressure being pumping to nozzles at the end of the hose lay, a smart technology of fire engines called Smart Flow Nozzle Wireless Piezometer was developed in 2008 by Joel Mulkey and Scott Malone (Joel Mulkey and Scott Malone, 2006). This technology is to control the fluid flow from the fire engines. This smart technology provides feedback for the fire engines with regard to one or more selected operating parameters. For example, the selected operating parameter could be the real-time water pressure coming out from the nozzle and the feedback will display on the panel at the fire engines for firefighters to visualize.

2.3.4 Fire Engine Auxiliary Power Units (APU's)

As is evidenced by the Hanshin earthquake, the spread rate of fires in urban environments has the potential to develop long lasting efforts that span over a draining timeframe. More local examples of this include fires which heavily damaged the Beijing Television Cultural Center in 2009. Witnesses report that flames burned for over 6 hours before they were completely extinguished (New York Times, 2009). Fire engines which are deployed to such incidents are expected to perform for these extended durations of time, which can potentially expend costly amounts of fuel while the vehicle is idling in place when in use.

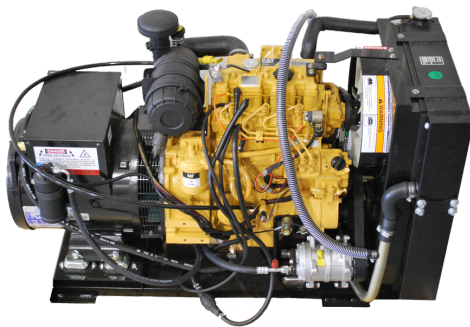

Figure 9 Smeal™ SG-09 (Smeal, 2013)



Figure 8 LCD Panel (Smeal, 2015)

In order to curb these costs, auxiliary power units (APU's) such as the Smeal™ SG-09 pictured in **Figure 9** have been developed. These devices contain onboard heating, ventilation, and air conditioning (HVAC) as well as a fuel-efficient generator; all of which are capable of running on a quarter of the fuel a fire engine would typically burn supporting identical systems. Software based controls operated through an LCD panel equipped on board the vehicle, pictured in **Figure 8**, can be utilized in order to customize which systems the APU is to supplant. Installed firmware, or permanent software, link to the engine's transmission system and allow the unit to automatically take over any assigned electrical function the moment the park brake is set. These power units not only have the potential to save costs, but also decrease the amount of strain put on engine components when running idle (Smeal, 2015).

2.3.5 Advanced Aerial Control Systems (AACS)

High rise fires which occur at elevations surpassing 100m necessitate the use of systems such as aerial apparatus and outriggers. Operation of these systems bring with it innumerable variables which demand immediate calculation and input from assigned personnel. Improper movement of an aerial can easily shift weight beyond the center of support provided by outrigger placement and could completely topple the engine and cause significant damages or even injury to firefighters on station.



Figure 11 Advanced Aerial Control System (AACS) (E-ONE, 2017)



Figure 10 Onboard Receiver FSE-727 (E-ONE, 2017)

Operation of these systems bring with it innumerable variables which demand immediate calculation and input from assigned controllers. Improper movement of an aerial can easily shift weight beyond the center of support provided by outrigger placement and could completely topple the engine and cause significant damages or even injury to on station personnel. To simplify the operation of these apparatus, E-ONE, a fire apparatus manufacturer based in Ocala, Florida, has developed the Advanced Aerial Control System (AACS), pictured in **Figure 11**. E-ONE's AACS features electric/hydraulic controls for smooth operation, including an LCD aerial information system display, wireless aerial and outrigger controls as well as a feature that allows the operator to select from preset ramp settings ($\frac{1}{4}$, $\frac{1}{2}$ and $\frac{3}{4}$ seconds). Most importantly, all

calculations for stability of both the aerial and outriggers are processed by the device itself, meaning that firefighters operating the AACCS can maneuver the components at a much faster and safer rate. This device connects to an on-board receiver such as the FSE-727 shown in **Figure 10**, which can be easily installed and linked to electrical and informational systems on board the chassis (Fire Apparatus & Emergency Equipment, 2016).

2.3.6 RFID Tagging and “Mobile Warehouses”

The range of responsibility for fire departments in an urban center are not limited to the threat of fire incidents exclusively. Concerns branch outward into categories focusing on rescue, social aid to other departments as well as other issues without formal classification. Overall, the dependence upon a city’s fire services is general and non-centric, as is identified by surveys completed by students of fire safety at Tsinghua University in Beijing, China. These students defined the responsibilities of a local department in Beijing to be 30% rescue, 30% aid, 30% fire and 10% other. Interestingly, even the deployment of fire suppression vehicles during an active fire is considered a secondary prerogative. Rescue specialized vehicles are always sent beforehand to reduce the endangerment of civilian lives. This large range of missions brings with it an even larger array of proprietary equipment. Managing, and even further, accurately deploying necessary tools and engine classifications to unique incidents can develop into a massive strain on an urban fire service’s organizational structure. In response to this, the Chinese People’s Armed Police Forces Academy has been developing a system of RFID tagging on equipment outfitted to a station’s engines. These digital tags wirelessly track the usage or presence of individual devices and could potentially expediate delegation during a specified incident class. Engines carrying these tagged resources have been dubbed “mobile warehouses” due to its nature as a transportable, catalogued stockpile. Unfortunately, the development of

necessary infrastructure and learning software to fully utilize these applications has been slowed due to security concerns over accessing a public network. Even so, the research and testing thus far ushers in a promising future for the expediency of fire response.

2.3.7 Radio Communications

While using aerial equipment such as ladders and hoses, there are very simple lines of communication operators rely on while the apparatus is in motion. During our interviews with several Chinese firefighters in consultation with Tsinghua University, they testified that many of them resort to shouting or using megaphones even despite their possession of handheld radios such as the Motorola GS 328. This unreliable command structure may result in accidents that can leave both firefighters and other personnel injured or killed in dire cases. The firefighters that were interviewed stated that their radios do not allow for priority traffic, meaning that all communicate are transmitted over a singular frequency regardless of their hierarchical origin. This echoes a need for a system that truncates, a function by which transmissions are passed through based on the rank of the person who is trying to relay a message. In the US, radios of the same company of Motorola have such systems in place as well as software that can be included to manually identify what messages are considered priority. This system allows for a more organized means of command in large scale incidents, where certain people can be in specific groups of the same channel while still scanning through the channel when pertinent messages from others come through. Overall, improving means of communicating instruction and information can save many firefighters as well as expensive damage to fire engine apparatus.

3.0 Methodology

The goal of this project is to develop a series of recommendations analyzing the potential implementation of smart technologies in Beijing and Wuhan's fire engines that will assist the WPI-Tsinghua Center for Global Public Safety to address the problem of operating fire engines in an urban setting. To reach this goal, we have:

1. Identified standard technical capabilities of an urban response vehicles
2. Compiled information on relevant smart technologies
3. Recommended specific smart technologies

Our project focuses on highlighting the real-world benefits of implementing smart fire technologies in order to encourage expiate the investment of and implementation of listed instruments following our departure from China.

3.1 Identifying Standard Technical Capabilities of an Urban Response Vehicle

Our project was conducted within and concerning the Chinese cities of Beijing and Wuhan. Therefore, proposed technologies as well as the overall sum of alterations to local fire engines our group proposed has been optimized for an urban environment. This stressed the need to find out what deficiencies and issues firefighters in these parts of China may face daily.

3.1.1 Benchmarking of American Fire Engines

Before leaving for China, we reached out to firefighters and handed out surveys to several fire departments in the United States to gauge what smart technologies they currently

have implemented on their fire engines and what smart technologies they would like to see implemented in the future. To identify the full-scale use of the current smart technologies that US fire engines are equipped with, we asked for information on the full specifications of the device, the purpose of the device, the advantages the firefighters perceive this device adds to the fire engine and if they know where the device has also been used both nationally or internationally. For smart fire engine technologies that US firefighters wish to acquire, we asked similar questions as well as why the device has not already been implemented. This gave our group the ability to identify the limitations that US firefighters and fire departments have in terms of technology.

Despite attempts to reach out to several departments including those located in Bridgeport, CT, Island Park, NY and Yarmouth, Maine, only a representative of Yarmouth was able to provide a response before our departure for China. The information which our group collected had centered around the technical outfitting of their station's vehicles. Essentially, data on hardware specifications and more importantly their handling. With this we developed a detailed understanding of their current capabilities and functionality. Yarmouth Fire Rescue, according to our respondents, is considered to represent the national standard held by the United States in terms of a department's technical outfitting. By utilizing this source as a point of reference, it provided our group proper comprehension of currently available resources and practices. Our group conducted these surveys in a short answer format. This setup provided much greater freedom by allowing open-minded responses to be formulated rather than being forced into a rigid questioning structure (Kajornboon, 2005).

3.1.2 Benchmarking of Fire Engines in Beijing and Wuhan

Following our arrival in China, we conducted identically structured surveys with officials and station personnel assigned to Beijing and Wuhan based fire departments. To schedule these interviews, we cooperated with our sponsor: the WPI-Tsinghua Center for Global Public Safety. We also received aid from the Chinese People's Armed Police Force Academy (CPAPFA) as well as the Wuhan University of Technology (WUT). Cooperation and identification of suitable interview subjects were made fluid through the aid of our personal contacts within these institutions. In particular, Tsinghua University has connections to all levels of provincial government as well as to the State Council (Tsinghua University, n.d.). As fire protection policies and services fall under jurisdiction of the Ministry of Public Security, we utilized these connections to provide necessary introductions to Beijing fire agencies (Ministry of Public Security, n.d.).

3.2 Compiling Information on Smart Technologies

After gathering the standard requirements for a Chinese and American urban response vehicle, we moved our focus towards the currently developing smart technologies in the United States as well as what similar advancements have been or are presently being developed in China. This section will discuss the method we utilized for surveying this information from US and Chinese firefighters and experts in the field of fire engine technology. The process involving US personnel occurred before the gathering of information on the Chinese urban response vehicle, but the analyzing of their responses occurred after.

3.2.1 Researching Developing Technologies in China

After interviewing both US firefighters and Chinese firefighters, we utilized our sponsor's deeply rooted connections in the Chinese public safety community. Their ties to local government officials and public safety programs were essential to finding information on new and developing technologies in the fields of fire protection, which encompasses fire engine technology. Through the experts at Tsinghua University and the CPAPFA, we found information on the current Chinese fire engines from three active first responders and three cadets respectively with first-hand experience concerning fire engines in these regions and a supported idea of what local issues firefighters and fire engines encounter. Specifically, through cooperation from the CPAPFA cadets, we were able to find out what current research projects are in place or had already been done to improve fire engines that may not be published or in production. To do this, we participated in formal tours which allowed us access to numerous facilities and pieces of equipment, along with the opportunity for informal interviews on the subject matter. When introduced to the developers and researchers of these technologies, we asked them the purpose of the device, their perceived benefits that the device contains and what problem in fire engine technology they believe it solves. Then based on the information that we received from interviewing both US and Chinese fire fighters, we compared the currently developing or researched smart technologies with the requests and preferences of the firefighters in both countries. This information has been documented for the WPI-Tsinghua Center for Global Safety to have and use when desired.

3.2.2 Comparative Analysis of Potential Improvements to Chinese Fire Engines

In order to effectively identify requisites for a fire engine, our group compared the data from both China and the United States. The rigorous benchmarking of fire engines from both locations provided the first step to this process. Utilizing information from departments of a similar but also completely foreign setting between them, inconsistencies or differences between the two will inevitably form. The inconsistencies we focused on are examples of technologies or methods utilized abroad which were not identified in China. This shone a light on current real-world implementations of improved systems which could potentially see use in Beijing or Wuhan.

Beyond this, the unique issues facing these Chinese cities were acutely reviewed through a survey distributed among local first responders, who are members that actively serve as the front line in combating fire incidents. Members of the survey group were once again notified and scheduled through our numerous institutional contacts. Due to the concise nature of the survey, our group was present to both administer and collect the documentation. However, we ensured the group's privacy as they completed their submissions. This survey included a short letter of introduction, with questions formatted as ranked response and short answer. Our background research of smart technologies allowed us to formulate identifiable technological categories. Examples included power generators, control systems or life support. The categories we identified were listed, and our survey group ranked each category in terms of the level of necessity they feel that technology has for improvement. All instructions relating to this ranking process were thoroughly described in the introductory letter. By acquiring this collection of observations, we then worked to apply these issues to our benchmarks; and reverse engineer technical solutions to those challenges. This process culminated in the development of definitive

requisites for a Chinese urban fire engine, built upon the technical solutions acquired both from our interviews and survey data.

3.3 Recommending Specific Smart Technologies

Once we gathered information about the standard requirements for a Chinese fire engines and current technologies in use in China, we identified potential technological upgrades for fire engines in Beijing and Wuhan. This section will discuss the methods for determining potential technologies and conflicts in implementing those technologies.

3.3.1 Compiling Potential Technologies

After compiling all of the data from the informal interviews and surveys, we created a list of all technologies that were either researched in the background section, or from the surveys that we had conducted and were referenced in section **3.2.2**. We then compiled a list of potential technologies that would benefit the Beijing and Wuhan fire departments, based upon the previously described list of technologies. Then, we determined several beneficial technologies that would assist the Beijing and Wuhan fire departments with the concerns they stated in previous surveys and discussion as part of section **3.1.2**, while also having a minimum impact to their current operating procedures as described in the previous section. For this, we developed two categories of recommended technologies including current and future technologies and the noted restrictions, the possibility of which is discussed in section **1.0**. Our currently implementable technologies category includes all items that can be used without having to use IOT, Cloud Computing, or big data. Our long-term technologies category includes items that

have multiple derived sources of information such as a building's schematics and the surrounding environments which both affect how a firefighter may approach a fire.

We accomplished this by comparing the information on each of the technologies with the data that we had gathered in our interactions with firefighters and fire officials. These potential technologies are the basis of our final proposal as well as our final presentation.

3.3.2 Determining Technology that Will Benefit Urban Fire Departments

This objective took the information we received from all experts of their respective fields as well as the problems both groups of firefighters have and their provided, potential solutions. Based on the concerns and limitations established in **3.1.1** and **3.1.2** and after performing section **3.3.1**, we determined which smart technologies listed in **3.3.1** avoid the limitations established by the American and Chinese firefighters. From the background and the interviews of firefighters, we established that many fire departments lack funds. Based on the lack of monetary funding, we only recommended items that can be simply and physically added to pre-existing fire engines. In the recommendations, we have placed a focus on cost effectiveness for the fire departments to decide if that that specific item would be well suited for implementation with their fleet of fire engines depending upon their relevant monetary funding.

4.0 Results

The following chapter consolidates research from both collected responses and open discussion as a result of our established methods. Research obtained from both US and Chinese contacts have been separated into their own sub-sections. Information is further organized into individual categories and summarized in bolded statements followed by relevant support.

4.1 US Results

Our group reached out to several US based fire departments in locations of varying background, including Island Park, NY, Bridgeport, CT and Yarmouth, Maine. The packages provided in our email request included a short-answer based survey requesting contextual information pertaining to those individual departments. This survey can be reviewed in appendix chapter **8.1**. Specifically, the distribution of incident class and both currently implemented and desired technological resources were focused upon. Unfortunately, due to extended difficulty in acquiring responses from both Island Park and Bridgeport, the following results will be solely based upon our data concerning Yarmouth, Maine. The Yarmouth respondent who provided the completed survey is a first responder and emergency medical technician (EMT) with a service record spanning over three years as of 2018.

4.1.1 Distribution of Incident Class

The majority of department responsibility lies in areas outside of actual fire incidents.

Yarmouth Fire Rescue provides support for a large diversity of incident class which spans the jurisdiction of several local emergency services. This department represents a combined team of both fire and emergency medical services (EMS); subsequently, most

incidents concern medical calls and requests for additional support through the deployment of station EMTs. The second highest frequency of responsibility cover incidents involving false triggering of carbon monoxide (CO) alarms and verbal requests for aid from concerned residents resulting from the presence of strange smells or other warning signs. Additionally, dense concentrations of major road networks in Yarmouth also precipitate a large number of traffic accidents which fire response assist in resolving, this being the next most prevalent incident type after false alarms. Interestingly, actual fires make up the least prevalent incident class handled by Yarmouth Fire Rescue. Actual fires are therefore classified among other high risk-low frequency events such as acts of terrorism or other threats of violence.

4.1.2 Currently Implemented and Desired Technologies

Smart alternatives to analogue devices have seen extensive implementation, while future focus has been placed on developing information-based networks.

Analogue systems and devices utilized in Yarmouth's fire engines which were previously man-operated have been progressively replaced with more self-calculating smart technologies. Smart pumps are installed which automatically choose the correct revolutions per minute (RPM) the vehicle's engine must produce to generate an input rate of flow to be fed into hoses or fixed deck guns. Previously, such settings would have to be incrementally reached through visual observation of the flow over a more inconvenient span of time. Fire engines are also pre-loaded with numerous tools and gear used on the ground by first responders, including smart devices such as hyper-accurate thermal imaging cameras. According to our respondent, their level of technological outfitting represents the minimum standard across departments in the US. Where Yarmouth has progressed in integrating isolated systems, they have also established a need for more widespread information networks cooperating with a GPS display. Specifically,

information such as the caller ID of the incident reporter as well as concise summaries on affected areas and buildings were noted as highly useful. These desires come with the hope for a system which emphasizes preparedness and expedient response.

4.2 Chinese Results

The following institutions represent the whole of our group's correspondents who participated in research efforts and cooperated throughout the project's execution.

Tsinghua University:

Tsinghua University is part of a group of many universities and organizations which are on the cutting edge of research and development for public safety. During our visit to Tsinghua University, we had the chance to interview three currently active firefighters, attend presentations and participate in conversations with experts in fire research who cooperated with departments within China. Two of the firefighters we interviewed were lieutenants from Beijing and Nanning, while the third firefighter was a squadron leader from Shanghai. The distribution of our research subjects is illustrated below in **Figure 12**.

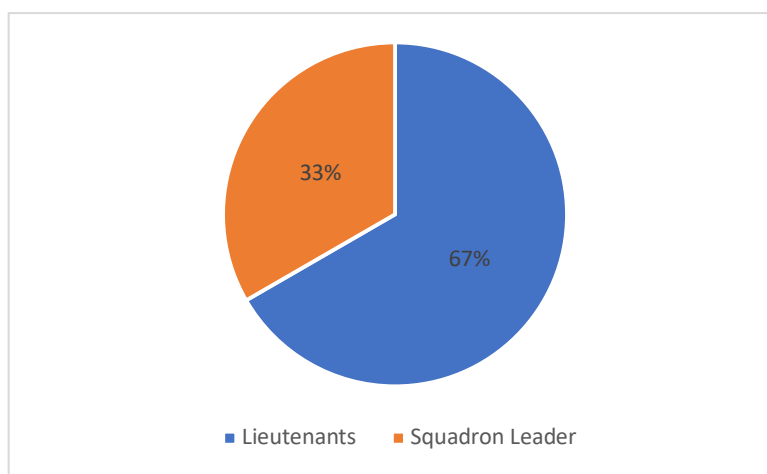

Figure 12 Tsinghua Firefighter Breakdown

Chinese People's Armed Police Force Academy (CPAPFA):

Similarly, the Chinese Armed Police Force Academy focuses on training and research for the continuous development of public safety. While there our group was able to speak with three cadets in training and attend presentations conducted by academy professors.

Wuhan Fire Department:

Our trip to the Wuhan Fire Department was arranged by the Wuhan University of Technology (WUT) with students from WUT aiding in the distribution and collation of surveys prepared by our group, which can be reviewed in appendix chapter 8.2. During our visit to the Wuhan Fire Department, we had the chance to interview seven currently active firefighters. One individual we interviewed was a lieutenant, another individual was a squadron leader with the remaining three individuals including one engine driver and two active firefighters. The distribution of our research subjects is illustrated below in **Figure 13**.

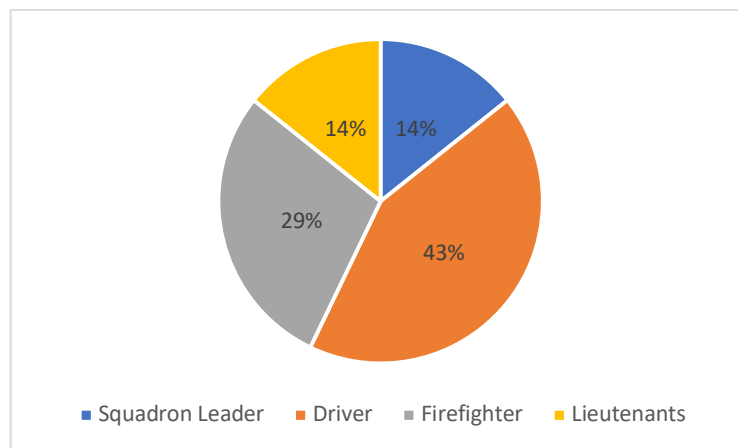

Figure 13 Wuhan Emergency Personnel Breakdown

Figure 14 outlines the core findings from these sources elaborated upon in 4.2.1-4.2.5.

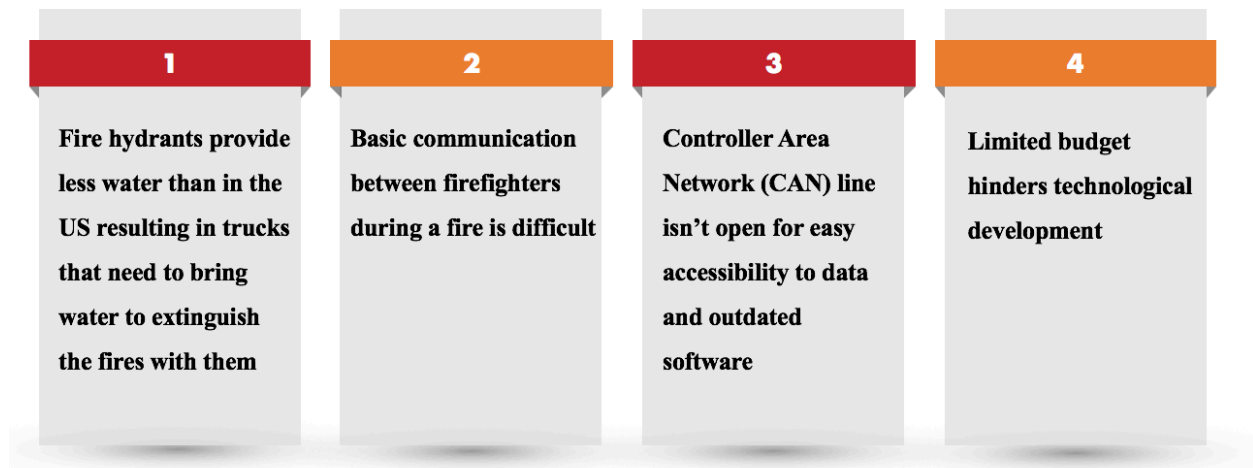

Figure 14 Data from Interviews

4.2.1 Social Infrastructures

Each fire department has several different fire engines that are used for either arriving at the site of the fire or extinguishing the fire.

Based on the responses from surveys conducted in Beijing and Wuhan, there are six core variants of fire engines commonly implemented in China. See **Table 3** below for details.

Fire Engine Variant	Purpose
Emergency Rescue Fire Engine	Most commonly used fire engine
Urban Main Fire Engine	Arrives first to the scene and supply water to the fire and assesses the situation. Outfitted with fire extinguishing equipment and can start extinguishing fires immediately
Water/Foam Tanker Fire Engine	For storing and water and foam to supply the other fire engines
Aerial Tower Fire Engine	Extinguish the fire outside the building

Aerial Platform Fire Engine	To help firefighters reach high rise buildings
Fume Exhauster Fire Engine	To exhaust the smoke in the fire spot

Table 3 Types of Fire Engines

The allocation of active fire engines highly depends on the resources of individual Chinese fire departments or stations which means not every department or station has each fire engine listed due to lacking funds. There are also rare cases that some fire departments or stations have more specific or uncommon variants of fire engines not listed in **Table 3**. Also, from the interview we identify that domestically produced fire engines are of a lower caliber of performance on average when compared to imported fire engines. The ratio of the imported fire engines to domestically produced fire engines is about 1:1, but it may differ in some areas due to the aforementioned disparities in available funds. In some cases, departments will utilize domestic shells over foreign chassis as a cost saving measure. The overall quality of imported trucks is superior, and the service length is usually longer. Imported fire engines have more developed functionality than domestically-made fire engines, with cited examples including superior hose systems for performance in elevated areas.

The need for improvements includes better communication and navigation software, equipment that can reach higher elevations, and more versatile fire engine capacity.

For future fire engines, improvements in the area of radio communication, equipment that could easily reach high-rise structures and software aiding in navigation as well as providing concise incident data are most preferred by firefighters. **Table 4** details the frequency of mention for each proposed improvement among our respondents. Please also note that an individual respondent can mention multiple proposals.

Features Desired in Future Fire Engine	Number of People Mention
Better radio communication	5
Equipments easily reach high buildings	4
Software to help navigation	4
Larger water/foam carving capacity	2
Others	3

Table 4 Surveyed Future Needs

Chinese fire departments have a diverse, top-down command structure.

Usually in given network of Chinese fire departments, the executive chain of command follows the structure illustrated in **Figure 15**. The department network is led by a singular fire chief with two battalion chiefs making up their second line of command. A varying number of captains work under the battalion chiefs with a similarly varied number of lieutenants working at the bottom of the executive chain.

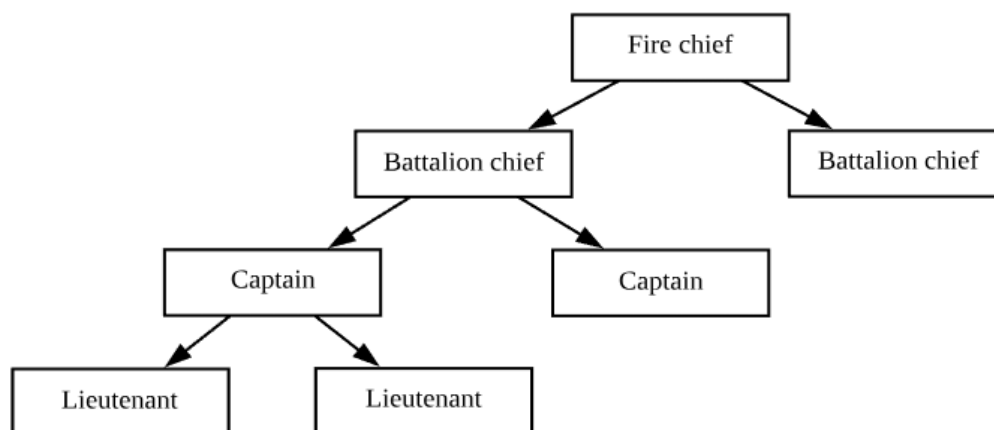

Figure 15 Hierarchy of Chinese Firefighters

The command structure following after the executive chain is illustrated in **Figure 16**.

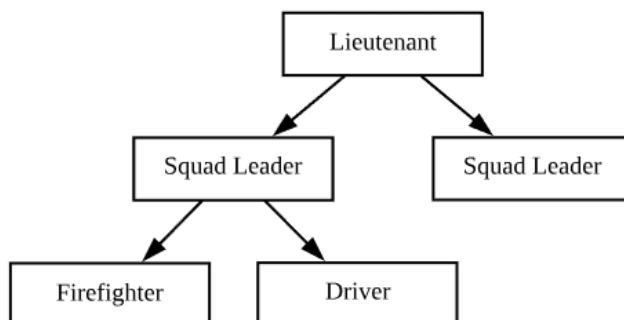

Figure 16 Hierarchy of Chinese Lieutenants

In the incident of a conventional active fire, the department's operational procedure in terms of response and deployment are listed below in **Figure 17**.

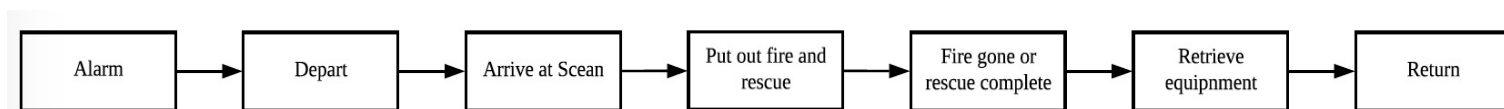

Figure 17 Chinese Fire Department Operational Procedures

Firstly, the fire department receives the alarm or call, then the commander at the command center dispatches specific fire engines and firefighters to the scene. Once arriving at the scene, the firefighters put out the fire or secure the endangered civilians. When the fire is gone, or the rescue is complete, firefighters will return to their engines to ensure all the equipment has been retrieved and proceed back to the fire department or station.

China's fire departments provide equal support between actual fires, rescue and aid.

For prevalent threats or incidents the Chinese departments face regularly, there is no commonly predominant threat that every fire department has due to the varying environments and locations of each fire station. It is identified that fire departments that are situated in and near large cities tend to have more incidents related to electrical fires and traffic accidents. On the

other hand, fire departments located in more rural and developing places have more rescue situations such as searching for people lost in the mountains. The common threats and incidents could be categorized into three main types. See the pie chart illustrated in **Figure 18** for detailed percentage values of those categories. The first type is aid which does not involve life threatening situations. Helping a cat stranded in a tree is one example. The second type is rescue which does involve life threatening situations. The third type represents fire incidents. There are other, more infrequent types of specific threats or incidents as well which are labeled as “others”.

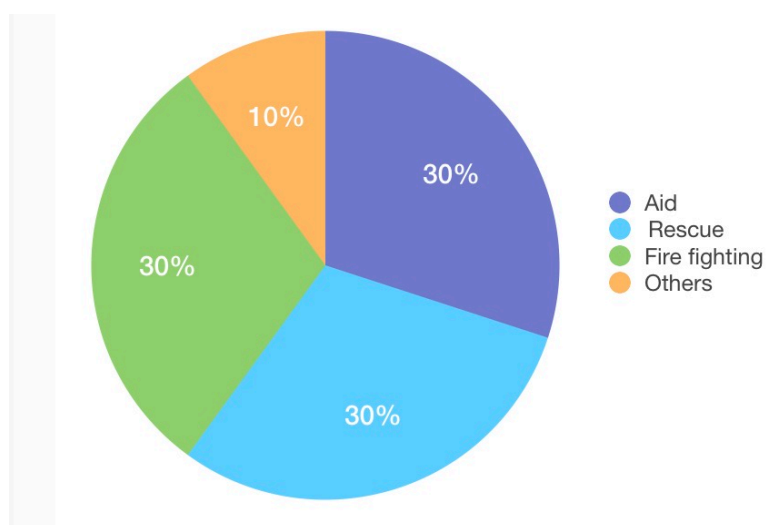

Figure 18 Prevalent Incident Breakdown

4.2.2 Physical Infrastructure

Lack of fire hydrants necessitate fire engines to carry large amounts of water when traveling to the scene of a fire.

When arriving in Beijing and Wuhan, we noticed that there were a limited amount of fire hydrants in and around the cities. While speaking with the three firefighters at Tsinghua University, we discovered that fire hydrants in China either do not hold much water or don't exist in certain locations. Therefore, in order to get water to the scene of a fire the firefighters

need to bring trucks that can carry massive amounts of water to extinguish the fire. However, also according to these firefighters, we found that fire trucks cannot hold too much water due to the extreme weight of the truck. The streets can potentially be too narrow for these trucks and elevated roadways are not rated to hold that much weight and could collapse if driven on.

There are many pieces of equipment firefighters use in and on the fire engine.

Both the Tsinghua and Wuhan firefighters stated that they have used items such as fire hoses, vehicle mounted fire hose nozzles also known as deck guns, guide rings to restrain hoses, entry tools such as axes and hydraulic spreaders which can be described as industrial jacks.

4.2.3 Budget Limitations on Technological Investment

Lacking available budget has rendered development of widespread or effective changes to fire engine technological outfitting exceedingly difficult.

During informal discussion with two cadets of the Chinese People's Armed Police Force Academy (CPAPFA), talks shifted to the costs incurred by individual departments because of routine annual spending. The cadets explained how the current rate of expenditure resulting from fuel costs as well as general maintenance of department resources had established a status quo for government investment. Essentially, what has developed is a static allowance to a system of state run fire departments depending on size and under an assumption of unchanging needs. This situation, according to the cadets, has made appeal for additional funds towards investing in new technologies increasingly difficult. Additionally, high costs of currently viable smart technologies have made the prospect of national integration a daunting affair. Any national investment towards technological progress within the armed services has largely been placed into universities such as the CPAPFA with the intention of funding general research missions.

However, without any prospect for future capital outside of isolated development, these efforts remain largely unproductive save for generating a base for later potential.

4.2.4 Network Restrictions

Global positioning systems are outdated causing firefighters to use their own phones to navigate to the scene of a fire.

Based on the interview and survey our group conducted in Beijing and Wuhan, we learned that the GPS presently in use by fire departments functions poorly. The fire department use their own network and proprietary software that do not share any information with other outside networks due to current security policies, which means the network is completely isolated. Thus, the GPS currently in use can't tell real-time traffic and road situations. According to the fire fighters, the GPS currently in use sometimes gives inaccurate information which makes navigation to active incidents a more time-consuming effort. That inaccurate information could include unmapped changes to road networks, directions utilizing roads that fire engines cannot go through because of the width and height of the vehicle and paths that are not the most expedient route. As the map does not update automatically from an online source, it needs to be updated manually. In place of this system, firefighters would use their own mobile phones to navigate during an incident, however their mobile phones don't connect to the command center making navigation more difficult. The firefighters want the engine's command terminal to provide all data for them so their responsibility is simplified to processing the provided data and information.

According to our interview and survey, we also identified that the Controller Area Network (CAN) line isn't open for easy accessibility to data. CAN line provides firefighters the ability to access the data on fire engines. This data includes current levels of water/foam/oil,

speed of the fire engine and so on. Firefighters want the manufacturers to open the CAN line so they can access the data of the fire engines easily. Unfortunately, both imported and domestically-made fire engines do not have open CAN lines and the expense of refitting the system is relatively high, reaching costs of 100,000-150,000 CNY per fire engine. Aforementioned budget restrictions affecting Chinese fire departments remove this option.

4.2.5 Inconsistent Communication

During the use of an aerial apparatus, control instructors on the ground resort to shouting because the radios they are equipped with do not perform reliably enough.

The operation of equipment such as the aerial apparatus requires constant communication to prevent damage to the equipment, the firefighters and lay persons in the surrounding area. Three firefighters at Tsinghua University stated that while operating equipment such as aerial ladders, a control instructor on the ground would use a megaphone or shout directions to the firefighter assigned to the control panel. Our respondents stated that they do have radios as a secondary form of communication, but because the channel has so many people utilizing it they find it difficult to relay their message without crossing conversations interrupting. Therefore, they believe that a system which allows for higher ranking officials to speak over the lower officials when important messages need to be announced would be a potential solution. Such a form of communication which utilizes these features would add to the overall safety while firefighters are working with and operating their fire engines and respective apparatus.

5.0 Recommendations

Our findings from both one on one interviews as well as informal discussions firmly establish a political climate in China which actively restricts the implementation of network based smart systems in Chinese fire engines. These limitations must therefore guide our process of recommendation to ensure the most expedient implementation of our researched smart technologies. Therefore, the following chapter has divided these technologies into two categories of recommendation relating to both present and future potential respectively. Present solutions will cover smart devices which interact with isolated, analogue systems on board an engine without the need for any connection to an outside network. Conversely, despite present restrictions, our group will also offer recommendations for technologies which are dependent upon such expanded networks. This is all to provide readily implementable improvements and a foundation of research for continued development in the eventual case of domestic policy shifts. The recommendations which our group has decided upon are outlined in **Figure 19**, with currently implementable solutions colored in red and future proposals in orange.

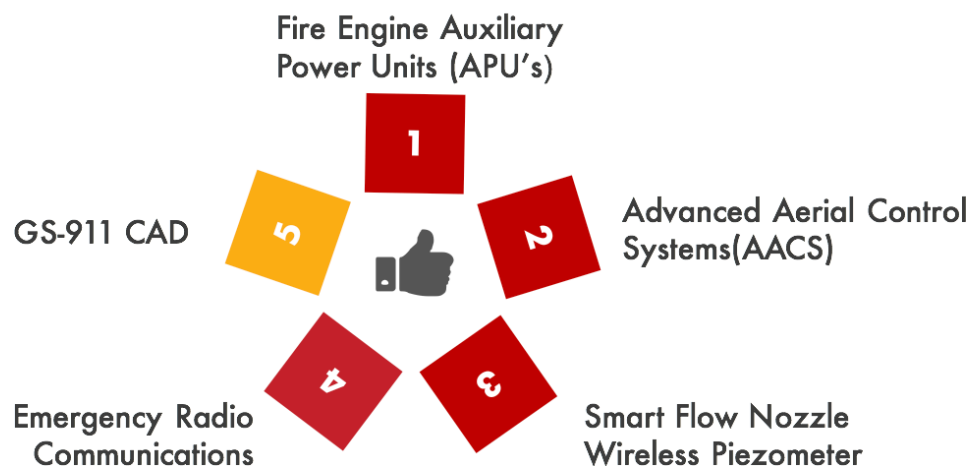

Figure 19 Diagrammatic Recommendations

5.1 Currently Implementable Recommendations

5.1.1 Fire Engine Auxiliary Power Units (APU's)

Data collected concerning the potential and effectiveness of analogue systems and command structures utilized onboard local fire engines in both Beijing and Wuhan reveal areas for growth which our research has found substantial basis. Fire protection representatives from both Tsinghua University and the Chinese People's Armed Police Force Academy (CPAPFA) named budget limitations as a great strain on department performance. One measure to cut costs is the reduction of diesel expended by engines during an active incident. Auxiliary power units, or APU's, such as the Smeal™ SG-09 could serve to reduce fuel consumption through the employment of a secondary and highly efficient diesel generator. Otherwise demanding systems which would place strain directly on the fire engines proprietary components would be circumvented by the APU while consuming less than a quarter of the diesel the engine would burn naturally. Reduced costs would come not only due to decreased fuel consumption, but also in the long term through reducing stress on engine componentry and increasing their lifespan (Smeal, 2015). While inspecting fire engines at the CPAPFA we questioned cadets on the feasibility of installing such a device. He directed us to the noticeably open undercarriages of their vehicles, while also noting their exposed and modular nature. **Figure 20** shows the open compartment dedicated to storing both tanks and electrical pumps responsible for supplying fuel to all main systems of the vehicle. Installing an APU in such a chassis would require minimal modification to its internal or external structure, as was also reassured by our cadet advisors.



Figure 20 Auxiliary Power Unit

5.1.2 Advanced Aerial Control Systems (AACS)

Low cost solutions to such expensive issues serve to progress departments' flexibility towards investing into solving other core problems which pose a more direct threat. Beyond cost lies the issue of time perpetuated by the complicated nature of man operated apparatus. Active scenarios of all classifications require expedient and precise application of resources and tools in order to minimize damages. However, these systems can often depend too heavily on human calculation to operate, placing even greater pressure on personnel in high risk scenarios. Recent developments in smart apparatus control systems could serve as an alternative to these more involved procedures. Presentations at Tsinghua highlighted the aerial apparatus as a greatly employed measure in urban settings to combat high rise fires and conduct complex rescue operations. Even with its high frequency of use, its control systems were described by cadets of the CPAPFA to be both lacking and un-adaptable. Controllers rely on instructions from a man on the ground to guide the aerial's movements. Improper movement can trigger electrical switches loaded with preset safety tolerances. Although effective in maintaining the stability of the vehicle, their lack of versatility and ability to conform to individual situations can often extend

the time necessary to resolve an active incident. Considering these concerns, we recommend implementation of the Advanced Aerial Control System (AACS) developed by E-ONE. The system's wireless panel can easily be deployed at any point on site, removing the necessity for a two-person command chain. Integration into the engine's already existing electrical tolerance switches can be made possible through the instillation of a wireless receiver such as the FSE-727 endorsed by E-ONE. While these safety measure on their own are incapable of applying information from its environment, the AACS is able to calculate and employ minimal alteration of aerial placement in the case of a destabilizing condition which triggers the switch.

5.1.3 Wireless Piezometer

Another area of great time consumption in deploying common apparatus is the application and use of fire hoses. Variables such as hose length and diameter, nozzle types, elevation and flow volume form innumerable scenarios which personnel on site must be capable of accurately discerning and calculating the necessary response. In order to curb these mounting responsibilities, we recommend implementation of the Smart Flow Nozzle Wireless Piezometer developed by Joel Mulkey and Scott Malone which was introduced to American departments in 2008. By natively controlling the flow of liquid within the hose, this smart technology can automatically act according to several simplified parameters input by qualified personnel. Although the requirement of human discernment has not been completely replaced, their responsibility in consistent management of the flow are largely reduced. Firefighters would no longer have to calculate the pressures based on situational conditions, but only provide more general information and allow the on board computer to more expediently perform those tasks (Joel Mulkey and Scott Malone, 2006).

5.1.4 Emergency Radio Communications

The need for better communication was also stressed by several firefighters during the interviews in both Beijing and Wuhan. In order to provide better and more controlled emergency communications to their emergency personnel, the United States and Europe have two organizations called P25 and TETRA which set standards and regulations allowing for most emergency personnel to communicate with one another even if they are from different organizations (The Critical Communications Association, n.d.) (P25, n.d.). Since the surveys specified that they would like a hierarchy system which automatically allows for personnel with higher authority to speak over lower level personnel as well as long range communication, the TETRA organization's terrestrial trunked radio system becomes very applicable and one of the best current solutions. A trunked radio system is a two-way radio system that assigns organizations and individuals to certain talkgroups where they can have conversations that do not have interfere with other groups who may be responding to emergency calls. An example would have having radios on the fire engine which are all part of a talkgroup so when they are called on an emergency they won't have the unrelated talk from the fire station coming over the air. When user in a different talkgroup want to talk with another talkgroup the two can be transferred to a vacant radio channel and not interrupt the conversations in the other two talk groups (Tannehill & Henry, 2006, p. 16). It essentially allows for many people to carry conversations over only a few frequencies. In order for commander to speak with and over talk small conversations, the commander can switch his radio to contact the lower ranking firefighters talk group and directly relay them a message. This is explained in **Figure 21**. Like most current radio communication

systems, they allow for mobile radios which are found in the trucks themselves to communicate with handheld radios.

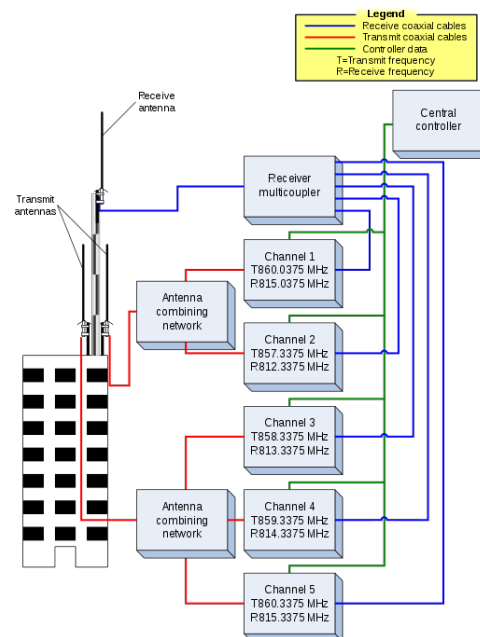

Figure 21 TETRA Diagram (David Jordan, 2007)

This system has many benefits and seems to be one of the best and already implemented in small scenarios. It has been used in Shenyang Metro, Guangzhou Electric Power, Shenzhen Metro and briefly during the 16th Asian Games in 2010 (Shenyang Metro, 2010). The system uses very low frequencies to the lesser number of frequencies resulting in longer ranges which can be easily amplified by either having a higher-powered radio or a larger antenna. During calls, there are fallback communication methods and mission-critical fallback networks can also be preprogrammed. Lastly, all channels and groups are all encrypted and kept from public use and interference. Overall, this system can be implemented by utilizing radio manufactured that are compatible such as Motorola and Ridgewood.

5.2 Future Recommendations

5.2.1 GS-911 CAD

The recommendations listed above would be able to be applied as is and in the current software and hardware climate that is in China. Beyond those recommendations we have for the current Chinese fire engine, there is a software which could be implemented in fire engine easily as long as the network problem solved. Currently, the network of all the fire departments is isolated and could not share any information with outside due to security issues. However, our group believe with the rapid progress of society and the development of “Smart City” in China, that software will widely be used in Chinese fire engine in the future. Based on the interviews and surveys our group have conducted in Beijing and Wuhan, our group recommend GS-911CAD for future fire engines in China. GS-911CAD is a smart command terminal physically attached to a fire engine’s control center to enhance effectiveness and safety for an active incident. Firstly, we recommend GS-911CAD since it provides various monitoring selections such as providing the current levels of gas, water or specialized extinguishing chemical within the fire engine through several sensors. That information will help firefighters to better putting out the fire during an active fire. In addition, it can calculate the estimated time left that the fire engine can fully function base on those levels specified. Moreover, the GS-911CAD is capable of not only identify the real-time navigation of traffic routes but also give the most efficient route to reach the incident site as quickly as possible. Furthermore, GS-911CAD is able to scan the firefighters and equipment in a certain fire engine and transmit that information to the command center responsible for acquiring detailed situations. Additionally, the GS-911CAD terminal at the fire engine could provide combat maps to share all information and other essential situation

reports for firefighter being deployed to the scene. This map includes information about the time of arrival for reinforcements and locations of suitable water sources nearby which improves the ability of communication between each fire engine during collaboration. In conclusion, although there is long way to go for solving the isolated network problem, our group still highly recommend the GS-911CAD since it will significantly help firefighters solve many problems they currently have as stated in section **4.2**.

6.0 Conclusion

The process of firefighting in an urban environment is one which carries with it many unique obstacles and potential for danger. Presence of particularly large and growing populations generate hindrances to departments through the massive, clogged flow of traffic through city streets. This is only further complicated through the presence of rapid urban expansion, both in the outward spread of road networks and upward momentum of high rise development. Our focus, the cities of Beijing and Wuhan, are two significant examples of urban growth and therefore face some of the more extreme incidents these environments can present.

Application of smart technologies and systems serve as a viable tool and active solution to many of the daunting tasks departments face in an active incident. Firefighters and fire protection representatives put into contact with us through our sponsor, the CPGS, all cite time and budget as their paramount limiting factors. Several proposed technologies provide cost saving measures in the short term, while also presenting long term solutions through more invested options. Beyond cost, smart systems have the unique ability to take on the burden of on site preparedness and raw calculation. Fire engine apparatus will become adaptable alongside their operators, cutting down the time required to resolve ongoing situations.

Our research and interviews reveal that regardless of their potential for aid, some technologies remain inapplicable due to current political climates. However, our overall goal remains to present a foundation of research even despite present day restrictions. This will ensure the security of future improvements to fire engine operation should outside policies change.

7.0 Works Cited

- Atlas of Urban Expansion. (2014). Beijing Atlas of Urban Expansion. Retrieved April 04, 2018, from http://www.atlasofurbanexpansion.org/cities/view/Beijing_Beijing
- Atlas of Urban Expansion. (2014). New York City Atlas of Urban Expansion. Retrieved April 30, 2018, from http://www.atlasofurbanexpansion.org/cities/view/New_York
- Atlas of Urban Expansion. (2014). Wuhan Atlas of Urban Expansion. Retrieved April 12, 2018, from http://www.atlasofurbanexpansion.org/cities/view/Wuhan_Hubei
- 北京市规划委员会 [Beijing Municipal Bureau of Urban Planning]. (2009). 北京中心城规划消防站分布图 [Beijing's fire station planning distribution map] [digital image]. Retrieved April 10, 2018 from http://shjsh.bjghw.gov.cn/web/static/articles/catalog_30100/article_ff80808122dedb360122ee6286360037/ff80808122dedb360122ee62e9b90039.jpg
- Beijing Municipal Bureau of Statistics. (2016). Beijing Statistical Yearbook. Retrieved April 12, 2018, from <http://tjj.beijing.gov.cn/nj/main/2017-tjnj/zk/indexeh.htm>
- Beijing's new highways connect area twice the size of New York. (2016, December 09). Retrieved April 04, 2018, from <http://www.scmp.com/news/china/policies-politics/article/2052657/opening-beijings-1000km-seventh-ring-road-more-closely>
- Botetourt County, VA. (n.d.). Retrieved April 12, 2018 from http://botetourtva.gov/government/documents/road_guidelines.pdf
- Botetourt County, VA. (n.d.). Will Emergency Services personnel be able to reach you when you need them? Retrieved April 12, 2018 from http://botetourtva.gov/government/documents/road_guidelines.pdf
- Brophy Haney, A., Jamash, T., & Pollitt, M. G. (2009). Smart metering and electricity demand: Technology, economics and international experience. Retrieved April 19, 2018 from <https://www.repository.cam.ac.uk/bitstream/handle/1810/229369/0905&EPRG0903.pdf?sequence=2>
- Bullough, W., Worden, K. and Haywood, J. (2003). Smart Technologies. London: World Scientific, pp.1-3. Retrieved on April 10, 2018 from https://app.knovel.com/web/view/khtml/show.v/rcid:kpST000006/cid:kt0046OSY9/viewerType:khtml/root_slug:1-the-smart-approach--an-introduction-to-smart-technologies/url_slug:smart-approach-an-introduction?&issue_id=&b-toc-cid=kpST000006&b-toc-root-slug=&b-toc-url-slug=smart-approach-an-introduction&b-toc-title=Smart%20Technologies&page=2&view=collapsed&zoom=1
- Chi, C., & Aizhu, R. (2003, October). Optimization of fire station locations using computer. Retrieved April 19, 2018, from http://en.cnki.com.cn/Article_en/CJFDTotat-QHXB200310025.htm
- China Discovery. (2018). Wuhan China Map [Map of mainland China]. Retrieved April 18, 2018, from <https://www.chinadiscovery.com/wuhan-tours/maps.html>
- Council on Tall Buildings and Urban Habitat. (2018). Number of 150m Completed Buildings. Retrieved April 19, 2018, from <http://www.skyscrapercenter.com/cities>
- Council on Tall Buildings and Urban Habitat. (2018). Beijing - The Skyscraper Center. Retrieved April 19, 2018, from <http://www.skyscrapercenter.com/city/beijing>

- Council on Tall Buildings and Urban Habitat. (2018). Wuhan - The Skyscraper Center. Retrieved April 19, 2018, from <http://www.skyscrapercenter.com/city/wuhan>
- The Critical Communications Association (n.d.). TETRA. Retrieved July 24, 2018, from <https://tcca.info/tetra/tetra/>
- David Jordan [GFDL (<http://www.gnu.org/copyleft/fdl.html>) or CC-BY-SA-3.0 (<http://creativecommons.org/licenses/by-sa/3.0/>)], via Wikimedia Commons
- English.gov.cn. (2014). Ministry of Public Security. [online] Available at: http://english.gov.cn/state_council/2014/09/09/content_281474986284154.htm [Accessed 9 Apr. 2018].
- Fire Apparatus & Emergency Equipment. (2016, April 26). E-ONE Displays Latest Aerial Fire trucks Controls At FDIC. Retrieved April 30, 2018, from <http://www.fireapparatusmagazine.com/articles/company-news/2016/04/e-one-aacs-aerial-fire-truck-controls.html>
- Fire Apparatus & Emergency Equipment. (2012, March 01). Justifying Aerial Apparatus. Retrieved April 30, 2018, from <http://www.fireapparatusmagazine.com/articles/print/volume-17/issue-3/departments/chief-concerns/justifying-aerial-apparatus.html>
- Fire Department of MPS. (2014). China Fire Services. Retrieved from <http://119.gov.cn/xiaofang/nbnj/33392.htm>
- Fireengineering.com. (2001). BACK-TO-BASICS PUMP OPERATIONS. [online] Available at: <http://www.fireengineering.com/articles/print/volume-154/issue-3/features/back-to-basics-pump-operations.html> [Accessed 28 Apr. 2018].
- E-ONE. (2017, August 25). E-ONE AACS [Image of the E-ONE Advanced Aerial Control System (AACS)]. Retrieved April 26, 2018, from <http://www.fireapparatusmagazine.com/articles/company-news/2017/08/e-one-wireless-remote-controls-fire-trucks.html>
- Gea, W., Yong-xing, J. and Yao-zong, S. (2011). The 3rd Generation Fire trucks and its Spraying Technique. *Procedia Engineering*, 11, pp.424-430. Retrieve on April 10, 2018 from <https://www.sciencedirect.com/journal/procedia-engineering/vol/11/suppl/C>
- Harris, W. (2005). How Natural-gas Vehicles Work. [online] HowStuffWorks. Available at: <https://auto.howstuffworks.com/fuel-efficiency/alternative-fuels/ngv3.htm> [Accessed 9 Apr. 2018].
- HBC Radiomatic. (2011). FSE 727 radiobus® [Image of the FSE 727 radiobus®]. Retrieved April 26, 2018, from http://customcontrolsinc.com/wp-content/uploads/2012/11/PI_FSE_727_US_ok_09_11.pdf
- Himoto, K., & Tanaka, T. (2003, January). Retrieved April 18, 2018, from https://www.researchgate.net/publication/237617683_A_Physically-Based_Model_for_Urban_Fire_Spread
- Huang Bo, Pan Xiaohong . (2006). GIS coupled with traffic simulation and optimization for incident response. Retrieved April 18, 2018 from http://randallboone.org/nr505/readings/Huang_and_Pan_2007.pdf
- Hubaux, J. P., Capkun, S., & Luo, J. (2004). The security and privacy of smart vehicles. *IEEE Security & Privacy*, 2(3), 49-55. Retrieved March 28, 2018, from <http://ieeexplore.ieee.org/abstract/document/1306972/>
- 干粉水联消防车 [Foam TenderFire trucks] (n.d.). Retrieved April 18, 2018 from <http://www.xzhz.com/en/product/xiao-fang-che-liang.jsp>
- Jacobs, A. (2009, February 09). Fire Ravages Renowned Building in Beijing. Retrieved April 30, 2018, from <https://www.nytimes.com/2009/02/10/world/asia/10beijing.html>
- Jacobs, A. (2015, August 17). In Tianjin Blasts, a Heavy Toll for Unsuspecting Firefighters. Retrieved March 20, 2018, from <https://www.nytimes.com/2015/08/18/world/asia/tianjin-china-explosions-firefighters-chemicals.html>

- Joel Mulkey, Scott Malone. (2006). Smart flow system for fire fighting. Retrieved April 18, 2018 from <https://patentimages.storage.googleapis.com/ef/64/73/965bb244b1de99/US20080041599A1.pdf>
- 成军 [Jun Cheng]. (2012). 浅谈我国消防车发展现状及未来趋势[Discussion on current situation and future development of fire engines in China]. Retrieved April,10, 2018 from <https://wenku.baidu.com/view/2cb20a4a6bd97f192379e908.html>
- K. Louise Barriball BA RGN , Alison While BSc MSc PhD RGN RHV Cert Ed (1994). Collecting data using a semi-structured interview: a discussion paper. Retrived from <https://onlinelibrary.wiley.com/doi/abs/10.1111/j.1365-2648.1994.tb01088.x>
- Khor, J. H., Ismail, W., Younis, M. I., Sulaiman, M. K., & Rahman, M. G. (2011). Security problems in an RFID system. *Wireless Personal Communications*, 59(1), 17-26. 10.1007/s11277-010-0186-2. Retrieved March 28, 2018, from <https://link.springer.com/article/10.1007%2Fs11277-010-0186-2>
- Kolesar, P., Walker, W., & Hausner, J. (1975, August). Determining the Relation between Fire Engine Travel Times and Travel Distances in New York City. Retrieved April 18, 2018, from https://www.jstor.org/stable/169846?seq=1#page_scan_tab_contents
- Lizhong, Y., & Dabai, J. (2003, February). The Relationship Between Fire and Socioeconomic Factors in China. Retrieved April 19, 2018, from http://en.cnki.com.cn/Article_en/CJFDTOTAL-GCKX200302009.htm
- MAPaPLAN. (n.d.). Beijing Map [Map of Beijing's inner city]. Retrieved April 18, 2018, from <http://www.mapaplan.com/travel-map/beijing-china-city-top-tourist-attractions-printable-street-plan/high-resolution/beijing-top-tourist-attractions-map-08-district-surrounding-area-must-do-location-jingshan-park-what-see-where-go-do-high-resolution.htm>
- Mulkey Joel, Malone, Scott. (2006). Smart flow system for fire fighting. Retrieved April 18, 2018 from <https://patentimages.storage.googleapis.com/ef/64/73/965bb244b1de99/US20080041599A1.pdf>
- Murnane, L. and Ruane, T. (2005). Fire detection and suppression systems. 3rd ed. Stillwater, OK: Fire Protection Publications, Oklahoma State University, p.10.
- Murphy, C. (2014, January 03). Chinas Urban Nightmare: Gridlock. Retrieved April 04, 2018, from <https://www.wsj.com/articles/no-headline-available-1388702641>
- N.d. (2013, October 23). Fire trucks Ladder [Image of a deployed fire engine]. Retrieved April 26, 2018, from http://trackitbahamas.com/?attachment_id=571
- NFPA. (2018, May 18). Fire department calls. Retrieved July 23, 2018, from <https://www.nfpa.org/News-and-Research/Fire-statistics-and-reports/Fire-statistics/The-fire-service/Fire-department-calls/Fire-department-calls>
- New York State Department of Transit. (2018). NYS Traffic Data Viewer. Retrieved April 29, 2018, from <https://gis3.dot.ny.gov/html5viewer/?viewer=tdv>
- NYC 911 Reporting. (2018, March 26). End-to-End Response Time. Retrieved April 19, 2018, from <http://www1.nyc.gov/site/911reporting/reports/end-to-end-repsonse-time.page>
- Roberts, M. R. (2011, November 02). Android app provides firefighters with GPS-based driving directions to an emergency. Retrieved April 3, 2018, from <http://americacityandcounty.com/fire/android-app-provides-firefighters-gps-based-driving-directions-emergency>
- People's Republic of China. Standing Committee of the National People's Congress. (2008). Fire Protection Law of the People's Republic of China (2008 Revision) Order No. 6 of the President of the People's Republic of China. China: President of the People's Republic of China Hu Jintao.
- Project 25 Technology Interest Group. (n.d.). Retrieved July 24, 2018, from <http://www.project25.org/>

- Roman, J. (2014). in pursuit of smart. *NFPA Journal*, 108(6), 40. Retrieved April 3, 2018 from http://wpi.summon.serialssolutions.com/#!/search?bookMark=ePnHCXMw42LgTQStzc4rAe_hSmECzeqaGOsaG1lEslBmHk1NgDnQ0pgDNtQPrJHNORmEPf0UAakKDgkM9QxT83RSCfyHNR4GlpKiUmApqeTmGuLsoQsrK-Ohw-nxwLaEqZG5qakRaNqYCEUAD-MqAQ
- Sharf, S. (2018, January 03). Full List: America's Fastest-Growing Cities 2017. Retrieved April 04, 2018, from <https://www.forbes.com/sites/samanthasharf/2017/02/10/full-list-americas-fastest-growing-cities-2017/#489a55093a36>
- Shenyang Metro. (2011, June 15). Retrieved July 24, 2018, from <https://www.railway-technology.com/projects/shenyang-metro/>
- Smeal. (2015). SG-09 SMEAL GREEN TECHNOLOGY. Retrieved April 30, 2018, from http://www.smeal.com/wp-content/uploads/LS-006-SG09-0715_sm.pdf
- Smeal. (2013, May 20). SG-09 Smeal APU [Image of the SG-09 Smeal APU]. Retrieved April 26, 2018, from <http://www.prweb.com/releases/2013/5/prweb10746910.htm>
- Smeal. (2013, May 20). SG-09 Smeal APU [Image of the SG-09 Smeal APU control panel]. Retrieved April 26, 2018, from <http://www.prweb.com/releases/2013/5/prweb10746910.htm>
- Tannehill, R., & Henry, M. (2006, December). TRANSPORTATION COMMUNICATIONS INTEROPERABILITY: PHASE 2 – RESOURCE EVALUATION. Retrieved July 24, 2018, from https://apps.azdot.gov/ADOTLibrary/publications/project_reports/PDF/AZ569.pdf
- Tsinghua.edu.cn. (2018). Tsinghua University. [online] Available at: http://www.tsinghua.edu.cn/publish/newthuen/newthuen_cnt/research/research-3-1.html [Accessed 9 Apr. 2018].
- U.S. Fire Administration. (2018, March 01). Fire loss in the United States. Retrieved April 29, 2018, from https://www.usfa.fema.gov/data/statistics/order_download_data.html#download
- Wang, F., Lu, S. and Li, C. (2005). Analysis Of Fire Statistics Of China: Fire Frequency And Fatalities In Fires. *Fire Safety Science*, [online] 8, pp.353-362. Available at: http://iafss.org/publications/fss/8/353/view/fss_8-353.pdf [Accessed 15 Apr. 2018].
- Wang, X. and Luo, J. (2015). Turbojet Fire trucks - Product - INTERSCHUTZ 2015. [online] Interschutz.de. Available at: <http://www.interschutz.de/product/turbojet-fire-truck/539514/C338204> [Accessed 28 Apr. 2018].
- The World Bank. (2018). Urban population growth (annual %). Retrieved April 29, 2018, from <https://data.worldbank.org/indicator/SP.URB.GROW?end=2016&start=2016&view=map>
- WPI. (n.d.). WPI-Tsinghua History. [online] Available at: <https://www.wpi.edu/research/centers/center-for-global-public-safety/history> [Accessed 18 Apr. 2018].
- Xiuyu, L., Hao, Z., & Qingming, Z. (2012, October 17). Factor Analysis of High-Rise Building Fires Reasons and Fire Protection Measures. Retrieved April 19, 2018, from <https://www.sciencedirect.com/science/article/pii/S1877705812032286>
- Xin, J., & Huang, C. (2013, October 04). Fire risk analysis of residential buildings based on scenario clusters and its application in fire risk management. Retrieved April 12, 2018, from <https://www.sciencedirect.com/science/article/pii/S0379711213001653>
- Zertuche, O. (2014, May 04). Cheaper Is Not Always Better. Retrieved April 07, 2018, from <http://businessadviser.co/cheaper-always-better/>

Zhao, J., Li, R., & Liang, X. (2016, August 11). Second ring is the most jammed road in Beijing: A view from taxis and Weibo. Retrieved April 04, 2018, from <http://ieeexplore.ieee.org/document/7538630/?reload=true>

Zhao, P. (2009, October 31). Sustainable urban expansion and transportation in a growing megacity: Consequences of urban sprawl for mobility on the urban fringe of Beijing. Retrieved April 04, 2018, from <https://www.sciencedirect.com/science/article/pii/S0197397509000757>

Zhang, R., Song, W., Yao, Y., Shi, C., Lou, Y., & Yi, W. (2015;2014;). Modeling regional ionospheric delay with ground-based BeiDou and GPS observations in china. *GPS Solutions*, 19(4), 649-658. 10.1007/s10291-014-0419-z
Zeeshan Aziz, Feniosky Peña-Mora, Albert Chen, Timothy Lantz, (2009) "Supporting urban emergency response and recovery using RFID-based building assessment", *Disaster Prevention and Management: An International Journal*, Vol. 18 Issue: 1, pp.35-48, <https://doi.org/10.1108/09653560910938538>

Zhong, M., Shi, J., Shi, C., Fu, T., & He, L. (2010). Study in performance analysis of china urban emergency response system based on petri net. *Safety Science*, 48(6), 755-762. 10.1016/j.ssci.2010.02.017. Retrieved March 28, 2018, from https://ac-els-cdn-com.ezproxy.wpi.edu/S0925753510000573/1-s2.0-S0925753510000573-main.pdf?_tid=a9489647-f65e-433a-a8b6-150928436e89&acdnat=1522212004_b7a6f7a5169b5452fd5358a082e96571

8.0 Appendix

8.1 American Survey

Smart Fire Truck Technology

Name: _____

Position: _____

Years served: _____

Fire department: _____

1. What are the most prevalent threats or incident classifications the department faces regularly? (Cats stuck in a tree, electrical fires, etc...)
2. What types of fire trucks does this fire department own? What are some key features of those current fire engine/s? If there are multiple, specify which attributes go to each truck.
3. What are the most commonly utilized apparatus which the station's fire engines are outfitted with?
4. Please name some, if any, examples of recent technological developments or improvements to the station's fire engines and, if applicable, describe the effects these changes have had.
5. Define what factors lead to the need to purchase a new fire truck?
6. What are some smart devices that are currently on your fire trucks?
 - a. Full specifications or how to find them?
 - b. What is the purpose of the device?
 - c. Do you feel that this device adds technical value to the fire truck? Does what it adds in complexity (if at all) does it make up in efficiency?
 - d. What advantages does this device give the fire truck?
 - e. Without this device, what would be entailed to replace this process? How much approximate time would this add?
 - f. Do you know if any other companies have used this nearby or internationally?
 - g. How did you hear about this upgrade?
7. What are some features that you desire in any future firetrucks?
8. How is the department's chain of command structured, and how do those ranks interact and support each other during an active incident?
9. In the incident of a conventional active fire, what are the department's operational procedures in terms of response and deployment?
10. Please, if possible, describe the resources allocated to the department from both internal and external entities in terms of equipment and information.

8.2 Chinese Survey

关于消防车的调查问卷

姓名： _____

职位： _____

入职年份： _____

消防队/所属部门： _____

调查日期和地点： _____

1. 部门面临最常见的威胁和事故？(例如：猫咪卡在树上， 电器着火等)
2. 部门现在拥有何种类型的消防车？在这之中最常利用的消防车是什么？有什么主要的特点？如果有多个，请分别指出对应的特点和车辆。
3. 在灭火过程中是否有明显的难题？（例如：锂电池的二起火， 货源不明情况下的灭火装置的选择）

4. 经常使用的消防车上有哪些灭火装备？

5. 最近是否在消防车和消防站有技术上有所发展或者提升？若有，请列举带来的影响。

6. 什么因素会影响／导致去购买新的消防车？

7. 现在消防车上的智能设备有哪些？

a) 它们的详细描述或者如何找到它们？

b) 这个设备的目的是什么？

c) 您是否觉得这个设备增加了消防车的技术价值？这个设备所怎加的复杂度是否（如果有）能被它提升的效率抵消。

- d) 这个设备给消防车带来了什么好处？
 - e) 如果没有这个设备，这个步骤会需要什么样的替代品？大约会增加多少时间？
 - f) 是否有其他公司（在周边或国际上）使用这个设备？
 - g) 您是通过什么渠道得知这个设备的？
 - h) 引进该智能设备的成本？（购置该设备的开支，预算是否充足，使用该设备可能所需要的培训周期）
8. 您希望未来消防车有什么特点或者装备？
9. 目前在交通拥堵和道路复杂的情况下如何实现迅速响应？是否用到交通智能优化方案？

