

**Designing a House for the 2019
Solar Decathlon Africa Competition**

A Major Qualifying Project

Submitted to the Faculty

of the

WORCESTER POLYTECHNIC INSTITUTE

in partial fulfillment of the requirements for the

Degrees of Bachelor of Science in Architectural Engineering

And Bachelor of Science in Civil Engineering

By:

Kelsey Leigher (AREN)

Alexis Moser (AREN)

Hayley Poskus (CE)

Patrick Schenkenberg (AREN)

Advisors:

Professor K.M. Elovitz

Professor S. M. Farzinmoghdam

Professor H. Saleem

Professor S. Van Dessel

This report represents work of WPI undergraduate students submitted to the faculty as evidence of a degree requirement. WPI routinely publishes these reports on its website without editorial or peer review. For more information about the projects program at WPI, please see <http://www.wpi.edu/academics/ugradstudies/project-learning.html>

ABSTRACT

This project consists of an architectural, structural, and mechanical design for a proposed house for the Solar Decathlon Africa competition taking place in Benguerir, Morocco, in September 2019. This project presents a sustainable, cost-effective, and marketable design that will help promote the idea of green living to African countries. Traditional architecture of the area, structural sandwich panels for modular construction, and a passive downdraft evaporative cooling tower to reduce energy were implemented.

AUTHORSHIP

Kelsey Leigher

Kelsey was responsible for the architectural aspects of the project. She also assisted in the mechanical design. She was the primary author of the following sections of the report:

- Capstone Design Statement
- Executive Summary
- Chapter 1: Climate
- Chapter 2: Architecture in Morocco, Passive Downdraft Evaporative Cooling Towers, Zion National Park Visitor Center, Architectural Program, Building Envelope, Windows
- Chapter 4: Thermal Comfort, Passive Downdraft Evaporative Cooling

Alexis Moser

Alexis was responsible for the architectural drafting aspects of the project presented in figures found within this paper as well as through a complete drawing set presented in the appendix. She also assisted in the structural design.

Hayley Poskus

Hayley was responsible for the structural aspects of the project. She also assisted in the architectural design. She was the primary author on the following sections of the report:

- Capstone Design Statement
- Professional Licensure Statement
- Chapter 1: Introduction, Solar Decathlon Africa, 2019, Site Selection
- Chapter 2: Code Compliance, Solar Decathlon Building Code, International Building Code, International Residential Code
- Chapter 3: Structural Design, Loads, Dead Loads, Wind Loads, Seismic Loads, Structural Framing Considerations, Beam Design, Structural Panels, Horizontal Structural Panels, Vertical Structural Panels, PDEC Tower Design, Adjustable Footings, RISA Modeling
- Chapter 5: Additional Considerations, Cost Estimate, Construction, Future Work
- Chapter 6: Conclusion

Patrick Schenkenberg

Patrick was responsible for the mechanical aspects of the project. He was the primary author of the following sections of the report:

- Chapter 2: Building Envelope, Exterior Wall System
- Chapter 4: Mechanical Design, Load Calculations, Cooling Loads, Thermal Resistance of Envelope, Peak Cooling Load, Heating Load, Evaporative Cooling, Passive Downdraft Evaporative Cooling, System Calculations, Mechanical Design, Ventilation of Air and CFM Values, Tower Performance, Water Consumption, Supplementary Cooling System

ACKNOWLEDGEMENTS

Steven Van Dessel, Advisor, for all your assistance and guidance throughout the entire design process.

Kenneth M. Elovitz, Advisor, for all your guidance through the design of the PDEC tower and evaluation of its performance.

Soroush M. Farzinmoghadam, Advisor, for your guidance throughout the architectural design and completion of the project.

Hussam Saleem, Advisor, for all your guidance with the structural design of the building.

Jenna Testa, Simpson Gumpertz and Heger, for your knowledge and assistance in envelope design and PDEC Tower mechanics.

CAPSTONE DESIGN STATEMENT

This Major Qualifying Project proposes a home design for the Solar Decathlon Africa competition taking place in Benguerir, Morocco in September 2019. A variety of knowledge gained from coursework was used in order to develop this design. The project contained architectural, structural, and mechanical systems for the proposed house.

Sustainability

Sustainability is the primary goal of the Solar Decathlon competition. Considerations toward sustainability included smart energy production through possible implementation of photovoltaic systems, water usage and collection, and passive designs such as the evaporative cooling tower. Accompanied by the architectural, structural, and mechanical designs, sustainability is a real-world practice and the strive for green design in this project.

Economic

Reducing cost of green living is another important goal for the Solar Decathlon. A cost estimate was produced to ensure that the house designed was feasible for both the competition and the marketed site. The structure of the house resulted in a square foot cost of approximately 12.3 US Dollars.

Constructability

The house design was based on the implementation of modular construction. This type of construction allows for a quick and easy assembly. Considerations included the materials used, building size, cost, and cultural and historical usage. The design applied the 2015 International Building Code, 2015 International Residential Code, and the Solar Decathlon Code book.

Safety

For structural safety, the house was considered both a living and exhibition space through the duration of the competition. The primary safety consideration in this design was adhering to the International Building Code and the International Residential Code.

Comfort

The mechanical system design followed the Solar Decathlon rules for temperature, humidity, and light intensity. Thermal comfort standards for Africa were also taken into consideration.

Marketability

The marketability of the house designed was an important factor to consider. The Solar Decathlon competition aims to market to the world that green and zero energy living is a more sustainable and healthy lifestyle. The modular construction of the home boasts fast and relatively simple assembly. The aesthetics of the home align with traditional Moroccan architecture. The PDEC tower is an innovative implementation of evaporative cooling for a residential home and has the possibility to be applied to future sustainable construction projects.

Ethics

The design held public health, safety, and welfare paramount by following the rules and codes set forth by the Solar Decathlon Africa competition, the International Building Code, and the International Residential Code.

PROFESSIONAL LICENSURE STATEMENT

Professional licensure is an imperative step for engineers. Earning professional licensure is a demanding process that was developed to protect the public by ensuring that all design is examined and approved by a competent and qualified Professional Engineer. Below, the requirements for obtaining a professional licensure are outlined.

In the United States, the step to achieving professional engineering licensure vary by state. However, in general, the process required four steps that are defined by the National Council of Examiners for Engineering and Surveying (NCEES). The first of these steps is successful completion of a Bachelor of Science degree in engineering from an Accreditation Board for Engineers and Technology (ABET) accredited program. Upon completion of this degree, the aspiring Professional Engineer must pass the Fundamentals of Engineering (FE) exam that is administered by the NCEES. After successful completion of the FE exam, the aspiring Professional Engineer will become an Engineer in Training (E.I.T). From here, the E.I.T. must acquire work experience, usually between 3 and 5 years) under the supervision of a Professional Engineer. However, the length of work that the E.I.T. must complete varies by states. In some states, the length of work can be shortened by other methods, such as obtaining a master's degree. Once the E.I.T. has completed the work experience, they must pass the Professional Engineering (PE) exam in their chosen discipline. After the PE exam is passed, the aspiring Professional Engineer may apply for a professional engineering license in the state that they plan to practice.

Due to these constraints, construction for this project could not begin without the approval of a Professional Engineer. All drawings and specifications would need to be reviewed and would need to be stamped and sealed by a Professional Engineer before the project continues.

EXECUTIVE SUMMARY

As organizations and populations begin to become more environmentally conscious, green architecture and net-zero energy living have become more widely acknowledged. The U.S. Department of Energy promotes these concepts by holding Solar Decathlon competitions throughout the world. This intercollegiate competition calls for teams to design a full-sized house that markets net-zero energy living to the average consumer.

This project demonstrates competency in creating an architectural, structural, and mechanical design of a proposed building to be entered in the Solar Decathlon competition taking place in Benguerir, Morocco in 2019. This building was designed to be a solar powered, net-zero energy home that follows the rules and codes for the Solar Decathlon competition and additionally functions in Morocco's hot, dry climate.

Architectural Design

Moroccan architectural styles and constructability concerns influenced the architectural design of the building. Geometric shapes and a closed-off floor plan reflect Moroccan style. The building is L-shaped with an attached deck area. The inside corner of the L houses an 18-foot-tall passive downdraft evaporative cooling (PDEC) tower. This tower is the main component of the mechanical system and the concept for the building. The building has a kitchen, living space, bathroom, two adjustable bedroom spaces, and an outdoor living space as shown in Figure 1. Note that the bedroom spaces in the figure are separated by a moveable partition for flexibility of spaces.

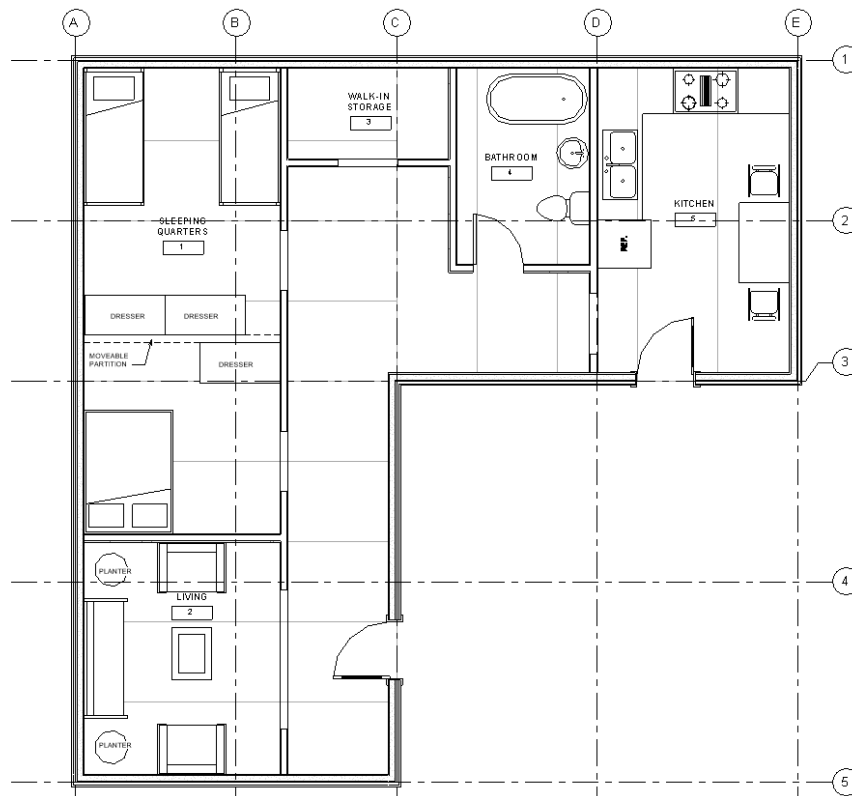

Figure 1: Architectural Floor Plan

The goal was to incorporate the necessary components for Moroccan lifestyle, as well as the requirements for the competition, and place them into a building that could be easily constructed during the competition's timeline. The inclusion of an attached deck area and the promotion of indoor-outdoor living reflects Moroccan lifestyle. High windows allow for privacy as well as the use of natural daylighting.

Structural Design

The structural design followed these objectives:

- Constructability – Use prefabricated pieces to decrease construction time and need for trained professionals.
- Cost – Utilize building materials and construction methods that are low cost.
- Sustainability – Implement sustainable materials and energy efficient design strategies.

Wood was selected as the main material of construction based on its ability to be locally sourced, its sustainability, and its structural capabilities. The structural design of this building includes beams and structural panels for the floor and roof system and a panel system for the walls. The structure of the PDEC tower is wood framed with cross bracing for lateral support to resist wind and earthquake loads. For both the floor and the roof, structural panels sit on a grid of beams. These panels consist of thin wood beams, rigid insulation, and plywood that work in unison to give the panel strength. A section view of the panels is shown in Figure 2.

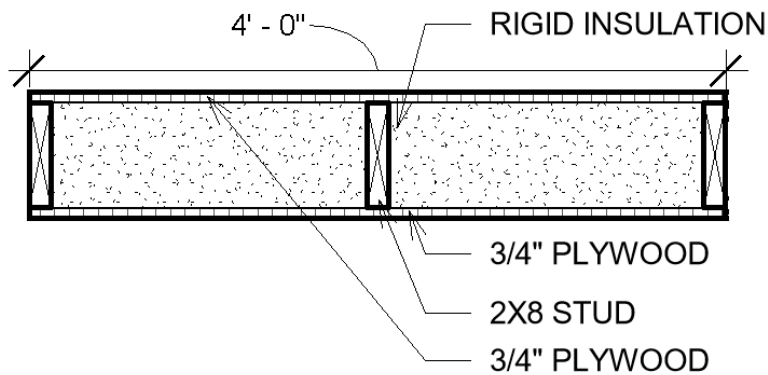

Figure 2: Floor Structural Panel Section

Another unique design choice was the use of adjustable footings. Adjustable footings allow for uncertainty in the terrain that the building will be set on. Slight variations in elevation onsite cannot be accounted for accurately ahead of time. Therefore, footings that can independently be adjusted allow for the house to sit flat on the competition site.

Mechanical Design

The mechanical design of the building was based on the hot, dry climate of Morocco and considered the codes and judging criteria of the Solar Decathlon competition. Overall, the desire to be innovative and creative inspired a mechanical design based on a passive downdraught evaporative cooling (PDEC) tower.

The PDEC tower draws in hot-dry outside air and humidifies it to lower the dry bulb temperature. This is a passive system that only uses energy to get water to the top of the tower where it is then sprayed into the air and evaporated. Air is moved through the tower due to the density difference between dry air and moist air. Throughout the design phase, peak heating and cooling loads, air ventilation, and the performance of the PDEC tower were analyzed. This analysis resulted in a conclusion that a PDEC tower would be effective in this situation but would need to be paired with a supplementary system that would aid in cooling during peak yearly temperatures.

Additional Considerations

Due to the nature of the Solar Decathlon competition, other considerations addressed during the architectural, structural, and mechanical design include:

- **Constructability:** Because the Solar Decathlon requires the overall construction phase to last one week, simple and fast construction using pre-fabricated pieces was used.
- **Transportability:** Non-local building materials that are used in the design need to be shipped to the competition in Morocco in shipping containers. The size of the materials also needed to be kept under consideration, for they had to fit in a shipping container.
- **Cost:** Prefabrication reduces the cost of building construction by making it simpler and uniform. Material Take-Off methods were conducted in order to determine the final cost estimate of the design.

TABLE OF CONTENTS

Designing a House for the 2019.....	1
Solar Decathlon Africa Competition.....	1
ABSTRACT.....	i
ACKNOWLEDGEMENTS.....	iii
CAPSTONE DESIGN STATEMENT.....	iv
PROFESSIONAL LICENSURE STATEMENT.....	vi
EXECUTIVE SUMMARY	vii
TABLE OF CONTENTS.....	x
LIST OF FIGURES	xiii
LIST OF TABLES	xv
INTRODUCTION	1
Solar Decathlon Africa, 2019	1
Site Selection	2
Climate.....	3
ARCHITECTURAL DESIGN.....	5
Architecture in Morocco.....	5
Passive Downdraft Evaporative Cooling Towers	6
Zion National Park Visitor Center	6
Architectural Program.....	6
Code Compliance.....	10
Solar Decathlon Building Code Requirements	10
International Building Code/ Residential Code Requirements	11
Building Envelope	11
Exterior Wall System.....	11
Windows	12
Roof.....	12
STRUCTURAL DESIGN.....	14
System Selection.....	14
Loads.....	15

Dead Loads	16
Live Loads	17
Wind Loads	17
Seismic Loads	18
Structural Considerations	19
Beam Design	19
Structural Panels	22
Floor Panel Design	23
Roof Panel Design	25
Wall Panel Design	26
PDEC Tower Design	27
Adjustable Footings	28
RISA Modeling	29
MECHANICAL DESIGN	30
Thermal Comfort	30
Load Calculations	30
Cooling Load	30
Thermal Resistance of Envelope	30
Peak Cooling Load	31
Heating Load	33
Evaporative Cooling	33
Passive Downdraft Evaporative Cooling	34
Ventilation of Air & CFM Values	34
Tower Performance	36
Water Consumption	37
Supplementary Cooling System	38
ADDITIONAL CONSIDERATIONS	40
Construction	40
Cost Estimate	42
Future Work	42
Architectural Design	43

Structural Design	43
Mechanical Design.....	43
Electrical, Plumbing, Fire Protection, Appliances	43
CONCLUSION.....	44
REFERENCES	45
APPENDICES	46
Appendix A: Structural Load Calculations	46
Dead Loads	46
Wind Loads.....	47
Seismic Loads	48
Appendix B: Structural Design Calculations	50
Symbols.....	50
Equations.....	50
Beam Design.....	51
Floor Panel Design.....	52
Roof Panel Design	54
Wall Sandwich Panel Design.....	56
Appendix C: Written Load and Structural Calculations	57
Appendix D: Total Building Weight.....	63
Appendix E: RISA Modeling Results	64
Floor Beams	64
Floor Panels	64
Roof Panels	64
Appendix F: R-value breakdowns for walls and roof	65
Appendix G: Cost and Labor Hours Estimate	66
Appendix H: Drawing Set.....	67

LIST OF FIGURES

Figure 1: Architectural Floor Plan	vii
Figure 2: Floor Structural Panel Section.....	viii
Figure 3: Map of Benguerir and Errachidia, Morocco.....	2
Figure 4: Climate Regions in Northern Africa. Taken from ASHRAE 90.1	3
Figure 5: Average Yearly High and Low Temperatures for Errachidia, Morocco	4
Figure 6: Humidity in Errachidia, Morocco.....	4
Figure 7: Typical Layout of Moroccan Homes.....	5
Figure 8: Zion National Park Visitor Center.....	6
Figure 9: Architectural Floor Plan	7
Figure 10: Cooling Tower Configuration	9
Figure 11: Exterior Rendering	9
Figure 12: Solar Envelope provided by the Solar Decathlon Africa.....	10
Figure 13: Exterior Wall System	11
Figure 14: Diagram of Natural Ventilation Utilizing Stack Effect	12
Figure 15: Section of the Building Showing Roof Construction	13
Figure 16: Beam Framing Plan	20
Figure 17: Tributary Width of a Beam.....	21
Figure 18: 3-Dimensional Representation of Structural Panels.....	23
Figure 19: Floor Panel Framing Plan.....	24
Figure 20: Floor Panel Section.....	25
Figure 21: Roof Panel Plan.....	25
Figure 22: Roof Panel Section	26
Figure 23: Wall Section Including Top Sill	27
Figure 24: Structural Box for PDEC Tower	28
Figure 25: Example of Adjustable Foundation Using Steel Plates and Screws from Simpson Strong-Tie	29
Figure 26: Peak heat gain through walls as a function of R-value.....	31
Figure 27: Peak Cooling Load Breakdown.....	32
Figure 28: ASHRAE 55 Comfort Chart.....	33
Figure 29: Water Usage	38
Figure 30: Placement of Adjustable Footings.....	40

Figure 31: Floor Beam Framing..... 41
Figure 32: Floor Panel Construction..... 41
Figure 33: Addition of Walls 42

LIST OF TABLES

Table 1: Solar Decathlon Judging Criteria.....	1
Table 2: Division of Spaces	8
Table 3: Required vs. Design Dimensions.....	10
Table 4: Comparison of Building Materials	15
Table 5: Summary of Design Loads	16
Table 6: Dead Loads (psf).....	16
Table 7: Live Load Requirement Summary.....	17
Table 8: Wind Information as Provided by the Solar Decathlon Competition	18
Table 9: Member Size Optimization.....	22
Table 10: Design Loads Acting on the Floor Panels.....	24
Table 11: Design Loads Acting on Roof Members	26
Table 12: Example Loads that Act on Exterior Wall Members.....	27
Table 13: Peak Cooling Load Breakdown and BTUH per square foot of floor area	32
Table 14: Yearly Temperatures, Average Relative Humidities, and Incident Required Cooling.....	36
Table 15: Required CFM for Various Temperature Ranges	37
Table 16: Impact and Requirements for a Supplementary Cooling System	39
Table 17: Electrical Requirements for the Solar Decathlon Africa	43

INTRODUCTION

The Solar Decathlon is a collegiate competition that challenges students by tasking them to design and build a full-size, solar-powered house. The goal of this competition is to teach both students and homeowners about sustainable building design. Houses are designed using innovative construction technology, sustainable materials, smart home solutions, and water conservation methods. For entry into the competition, a proposal highlighting the building's concept must be submitted. Once selected to compete, architectural, structural, and mechanical designs, accompanied by drawing sets, are required to participate. The building is constructed, toured by visitors and judges, tested, and deconstructed all during the three-week course of the competition. Teams are then judged on ten pre-established criteria, hence the name “decathlon.”

Solar Decathlon Africa, 2019

In 2016, environmentally conscious groups in Morocco combined forces with the U.S. Department of Energy to develop the Solar Decathlon Africa. This African adaptation of the competition is expected to take place in September 2019 on the campus of Mohamed VI in Benguerir, Morocco. Solar Decathlon Africa comes at a time when African countries are focusing on promoting sustainable lifestyle. The African Solar Decathlon will be judged on ten criteria as follows:

Table 1: Solar Decathlon Judging Criteria

Criteria	
1	Architecture
2	Market Potential
3	Engineering
4	Communications
5	Innovation
6	Water
7	Health & Comfort
8	Appliances
9	Home Life
10	Energy

Each of the ten categories has several subcategories that further describe the requirements in detail. The full list of judging criteria can be found in the rule book governing the competition. Teams must fulfill each category's and subcategory's criteria to the best of their ability to earn points. Judges determine the winner of the competition by whichever team accumulates the most points.

For the purpose of this Major Qualifying Project, the rules and mission of the Solar Decathlon guided most of the project's direction and decisions. It should be noted, however, that not all the

competition entry requirements were met with this project due to time restraints. The goal of this project in relation to the Solar Decathlon was to compile a design that had potential to be submitted as a competition proposal. If accepted into the competition, a future MQP could pick up where this project was left off to complete it for the Solar Decathlon.

Site Selection

One of the categories considered for judging is the market potential of the house designed. A goal of the Solar Decathlon is to make green living accessible for everyone. Because of this, houses entered in the competition need to appeal to consumers. To assist in creating a marketable home, the competition requires that a "storyline" for the building be submitted. Creating a storyline involves determining a specific location in the world in which the building can be marketed and the type of person it should be marketed for. When selecting a site for this project, it was important to choose a location with a climate similar to Benguerir, Morocco. This meant we designed a building that worked not only on the storyline site, but also during competition in Benguerir. For this project, the house was designed for the city of Errachidia, Morocco. The two cities are about 325 miles (523 km) apart from one another. Benguerir falls on 32.2°N latitude while Errachidia is less than half a degree south at 31.9°N latitude. The locations of Benguerir and Errachidia can be seen below in Figure 3.



Figure 3: Map of Benguerir and Errachidia, Morocco

Climate was the driving force behind the site selection. Selecting Errachidia, a city that is relatively close to Benguerir, meant that the climate of the storyline city was very similar to the climate of the competition city. This was ideal for the project because it allowed the mechanical design to be consistent for both competition and marketing. It also meant the home's mechanical systems could work properly in both the storyline and competition settings. Figure 4 shows the climate regions of northern Africa and southern Europe. Morocco is primarily zones 2B and 3B, "hot dry" and "warm dry"

respectively. Both Errachidia and Benguerir fall into the "warm dry" zone, with Benguerir being right on the border of zone 3A, "warm humid."

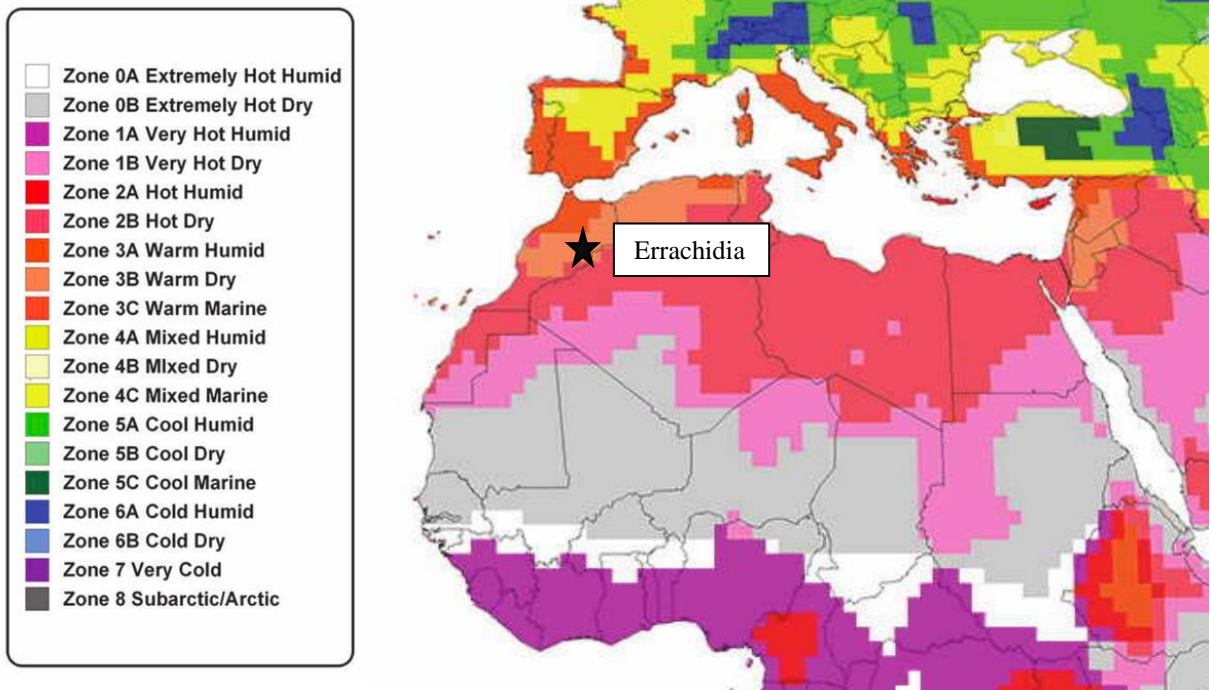
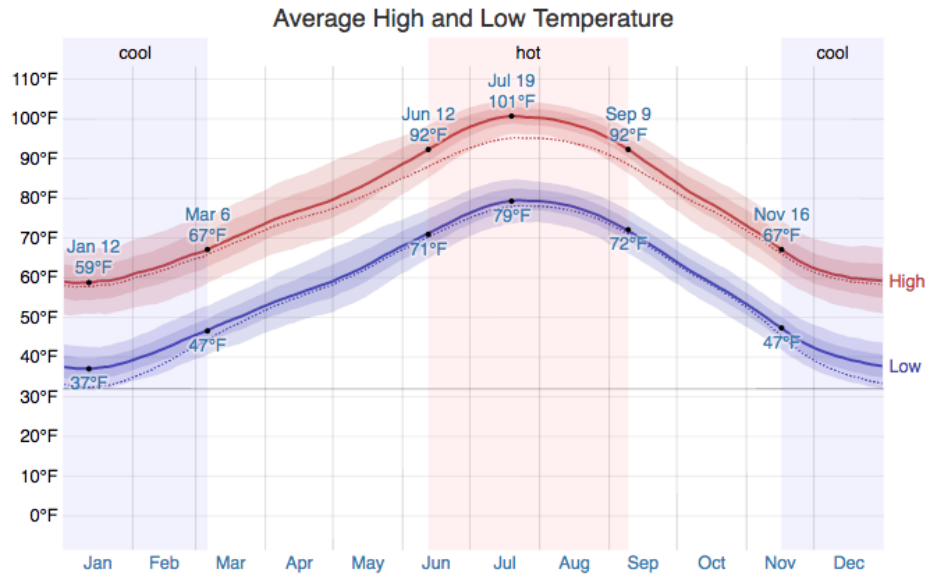

Figure 4: Climate Regions in Northern Africa. Taken from ASHRAE 90.1

Climate

The climate was a driving factor for the selection of Errachidia as a target location. The hot season lasts from June to September and the cool season lasts from October to May. Overall, Errachidia is a very dry climate, with extremely low precipitation and humidity levels. Throughout the year the average high temperature in Errachidia is 92°F and the average low is 67°F. Figure 5 displays the average yearly temperature trends in the city. The highest average temperature is 101°F and the lowest average is 37°F.



The daily average high (red line) and low (blue line) temperature, with 25th to 75th and 10th to 90th percentile bands. The thin dotted lines are the corresponding average perceived temperatures.

Figure 5: Average Yearly High and Low Temperatures for Errachidia, Morocco

Errachidia, Morocco is a hot desert climate. Figure 6 shows the perceived humidity throughout the year in the city. Perceived humidity is a gauge for comfort and refers to the percentage of people who consider the air humid. For the majority of the year, there is 0% perceived humidity, meaning that no people feel the air is humid or muggy. For one month, August, that humidity raises to 1%. A dry climate such as this lends to the use of a cooling system which also can produce humidity for increased comfort.

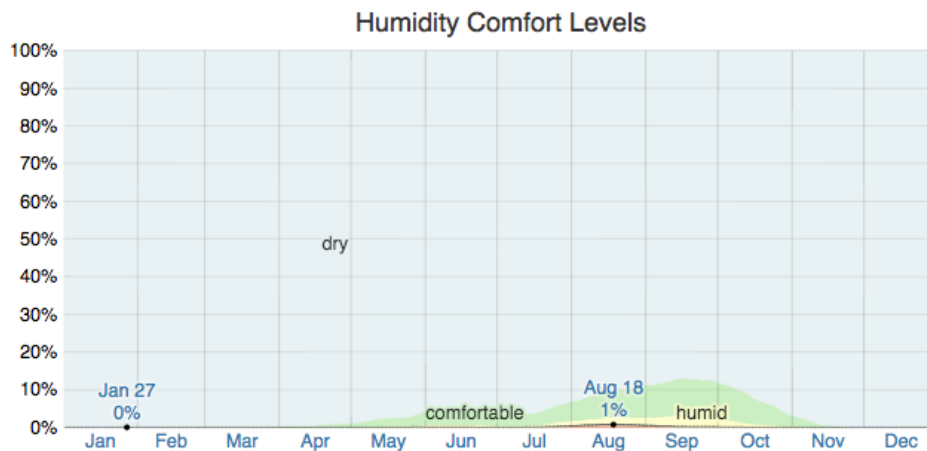

The percentage of time spent at various humidity comfort levels, categorized by dew point: dry < 55°F < comfortable < 60°F < humid < 65°F < muggy < 70°F < oppressive < 75°F < miserable.

Figure 6: Humidity in Errachidia, Morocco

ARCHITECTURAL DESIGN

There were three main goals when producing the design concept of the house:

1. Combine traditional Moroccan architecture with modern technologies and living styles.
2. Implement an innovative passive cooling system that reduces energy consumption.
3. Keep the constructability of the building simple and fast with the use of prefabricated pieces.

The goals behind the design of the building greatly influenced the architectural design and layout.

Architecture in Morocco

The Solar Decathlon Africa website states, "*It is important to remember the heritage of Africa and incorporate some of these traditional styles, arts and materials while building for the future.*" When designing a home for the competition, it was important to keep the architectural style of Errachidia, Morocco in mind. Moroccan architecture represents the country's unique past while combining both European and Islamic influences. The most common type of house in Morocco is traditionally called the "Dar." The Dar has an interior courtyard with a small number of specialized rooms that surround it in a rectangular layout. Courtyards are culturally important because they allow for large gatherings of people. Interior-facing windows and L-shaped entryways increase privacy and decrease noise from busy streets. Typical layouts of these houses can be seen below in Figure 7.

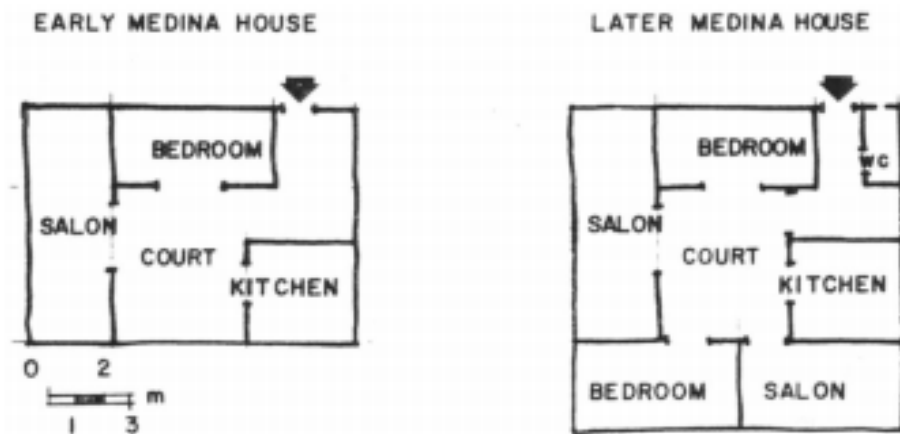

Figure 7: Typical Layout of Moroccan Homes

Housing in Morocco is most commonly constructed using concrete, masonry, or adobe materials. Typically, rammed earth, thick adobe brick or concrete walls are used for the overall structure to provide thermal mass, which helps to keep the hot air out of the building's interior. Additionally, palm wood is often used in order to provide a structural frame.

As for the façade of buildings in Morocco, typical low-cost structures utilize concrete or brick. However, some structures have begun to implement stucco into the façade. Stucco allows for designers to

carve ornamentation into the walls and roof of the structure. This is often done in Morocco due to the unique cultural beauty it gives a building.

Passive Downdraft Evaporative Cooling Towers

For the building, the central component of the mechanical design also acts as the main concept of the architectural design. This piece is an 18-foot-tall passive downdraft evaporative cooling tower. The inspiration for the implementation of a cooling tower came from researching the Zion National Park visitor center located in southwestern Utah.

Zion National Park Visitor Center

Zion National Park, located in southwestern Utah, is noted as a high-performance building that achieves extreme levels of energy efficiency. With 67% less energy costs, the Zion Visitor Center is much more sustainable than the average commercial building (Torcellini, 2005).



Figure 8: Zion National Park Visitor Center

Like the goal of the Solar Decathlon, energy efficiency was the main goal during the design phase of the Zion National Park visitor center. To achieve this, various innovative construction and mechanical methods were used in the architectural, structural, and mechanical designs. This included the implementation of passive downdraft evaporative cooling (PDEC) towers. By utilizing the concept of stack effect, these PDEC towers are the primary means of providing cooling for the building.

Architecturally, the towers stand out when looking at the building. Nestled in the interior corners of the W-shaped building, the location of the PDEC towers provides optimum cooling power for the interior of the building. Their location is relatively centralized in comparison to the structure. Additionally, being settled in the existing corners of the building avoids the need to lose any usable floor surface area to house the PDEC tower. Being in the corners also allows for optimizing the towers' attachments to the building itself.

Architectural Program

After establishing the goals and objectives of the design and gathering relevant research, an architectural program was determined. Throughout this process, different factors such as the flexibility in

the floor plan, the flow from space to space, and priorities in house features were considered. All of these factors helped to determine the architectural design.

The floor plan of the house, shown in Figure 9, is an L-shape that is centered around a central PDEC tower. It also has a covered outdoor living area. Moroccans prefer a more closed-off floor plan rather than the more modern open-concept floor plan. Because of this, each room in the house has a defined space. In efforts to make the home more modular, however, we proposed the use of interior partitions rather than full framed walls.

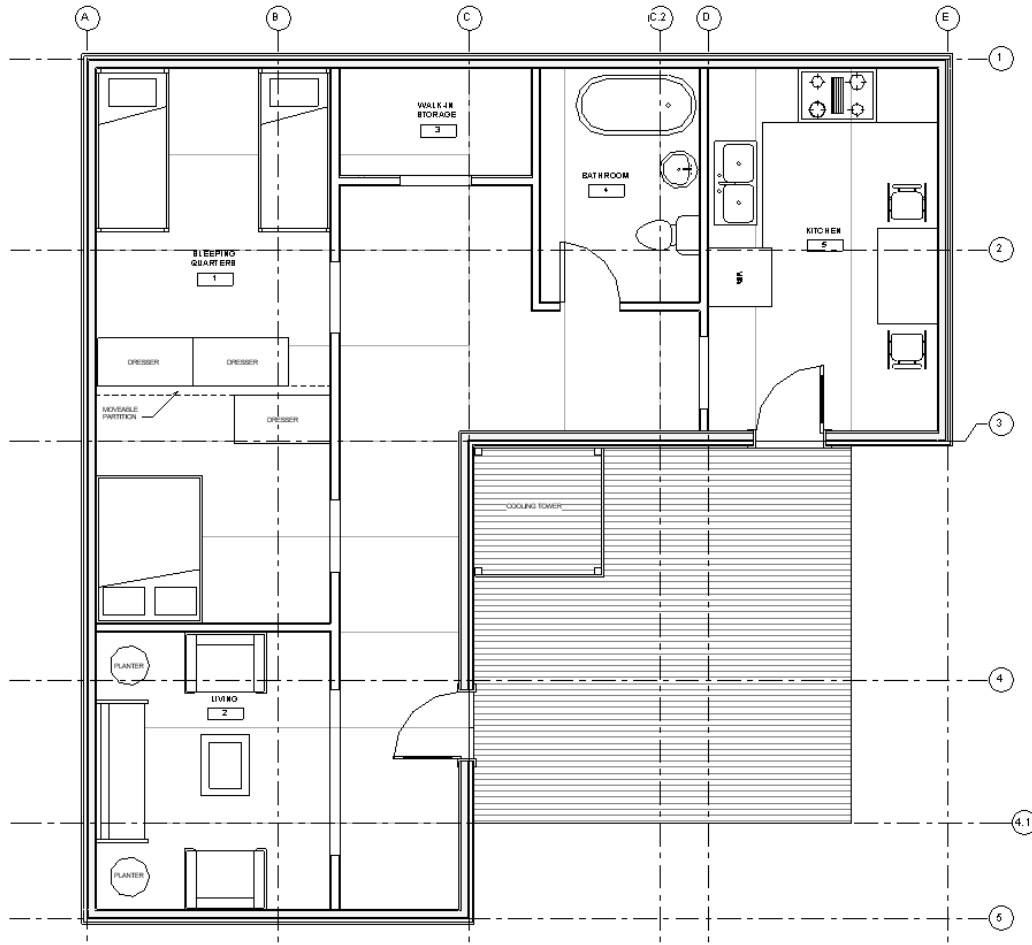

Figure 9: Architectural Floor Plan

The L-shaped floor plan is divided into two portions. One half of the “L” contains the kitchen and the bathroom. The other half of the house holds all of the living areas including the bedrooms and living/gathering room. This was done for many reasons. The grouping of the kitchen and bathroom in one section of the house limits the amount of “wet walls” in the building. A wet wall contains water supply pipes or drains. Because both the kitchen and the bathroom have water supplies, it was important to consider how that water will be supplied and through what walls. In an effort to use only one wet wall in the house, the kitchen and the bathroom were placed next to each other. Another reason for this divide is the amount of heat that is given off by a kitchen. Because cooking requires a substantial amount of heat

which cannot always be directly ventilated out of the house, it was important to separate the kitchen from the direct living areas as much as possible to keep them at a reasonable temperature.

According to the Solar Decathlon Africa Rulebook, the architectural design should respond to the needs of a five-member household. Therefore, it was determined that the space should be divided as shown in Table 2.

Table 2: Division of Spaces

Space	Square Footage (SF)	Percent Total SF
Living Quarters	288	32 %
Living Area	192	22%
Kitchen	160	18%
Bathroom	60	7%
Public Space/ Storage	196	21%

At least two bedrooms (or a large hostel-like living quarters) were essential for a five-member household, therefore a large living quarter was created with the option of a moveable partition. A designated gathering location in the house was also very important. Moroccans commonly host large gatherings in their homes, therefore, a decently sized living area was considered.

A large portion of the architectural design of this building was a Passive Downdraft Evaporative Cooling Tower situated in the interior corner of the L-shaped floor plan. This tower was influenced from the Zion National Park Building that was described above. The tower is 5 feet wide on each side and reaches 18 feet in height.

The width of the tower was based off of the system calculations that are presented in the mechanical section of this report. The 18-foot height was based off of the maximum building height listed in the Solar Decathlon competition as well as the system calculations. The PDEC tower's location, as shown in Figure 10, was chosen for a few reasons. First the tower rests against each side of the building, it provides both air exchange and cooling for both portions of the building simultaneously. In addition to being able to cool the interior of the building, the cooling tower's location also provides potential for cooling the exterior living space connected to the building. More information about the cooling tower and its mechanics can be seen in the Mechanical Design section.

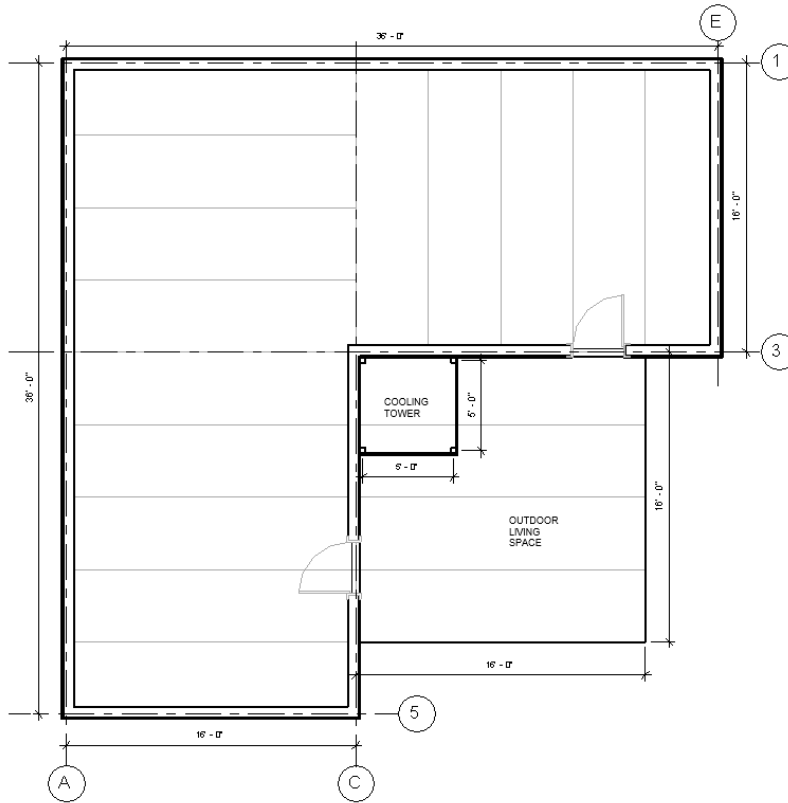

Figure 10: Cooling Tower Configuration

The cooling tower is also used to support a canopy for shading the outdoor living space. Shading considerations were a necessary part of the design process and is a common practice in Moroccan architecture. Suspending a lightweight canopy from the cooling tower provided shade for the exterior living space as well as the side of the building interior. The full design of the building with the cooling tower and canopy can be seen in Figure 11.



Figure 11: Exterior Rendering

Code Compliance

The Solar Decathlon Building Code, the International Building Code (IBC), and the International Residential Code (IRC) were the determining factors for many design aspects of this house. These codes present guidelines and rules for buildings that must be followed. Following these codes allow engineers to approve and stamp the designs so that they may be constructed.

Solar Decathlon Building Code Requirements

The Solar Decathlon provides competitors with rules and a code book that must be followed in order to compete. Within these rules, many different factors are determined.

When designing the overall shape of the building, the allowed solar envelope was considered. The solar envelope dimensions, as provided by the Solar Decathlon Africa Rules, can be seen below in Figure 12 (Solar Decathlon Africa, 2018).

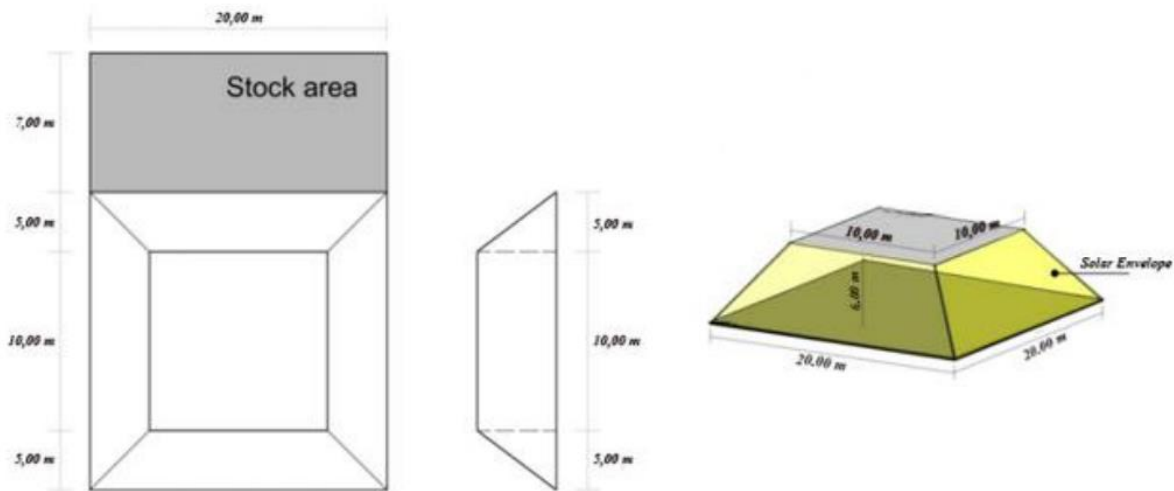

Figure 12: Solar Envelope provided by the Solar Decathlon Africa

Along with the solar envelope, the rule book also provides minimum and maximum values for the measurable area of the building. As stated, “the measurable area shall be at least 55 m² (600 ft²) but shall not exceed 90 m² (970 ft²).” This means that the measurable square footage, not including deck-space, storage space, or space required for photovoltaics of the building should be within these values.

Table 3: Required vs. Design Dimensions

	Required	Design
Measurable Area	600-970 ft ²	896 ft ²
Maximum Height	19.7 ft	18 ft

International Building Code/ Residential Code Requirements

The building designed must not only follow Solar Decathlon requirements but must also adhere to the International Building Code (IBC) and the International Residential Code (IRC) requirements. Because the structure entered into the competition must be both a residential and exhibit space, it must follow the codes that these structures fall into.

Building Envelope

The building envelope is made from insulated sandwich panels that can be prefabricated and put into place once on site. An exterior façade is specified to fit the aesthetic expectations of Morocco. Windows have also been included to allow for natural lighting and ventilation.

Exterior Wall System

The main component of the exterior walls are the panels. These are 3½ inch polystyrene panels sandwiched in between two ¾ inch plywood sheets. The exterior sides of the panels have four horizontal furring strips going across lengthwise with air space between them. The studs support the façade, which is currently plywood but can be changed to suit different aesthetic requirements. A visual representation of the exterior wall system can be seen below in Figure 13.

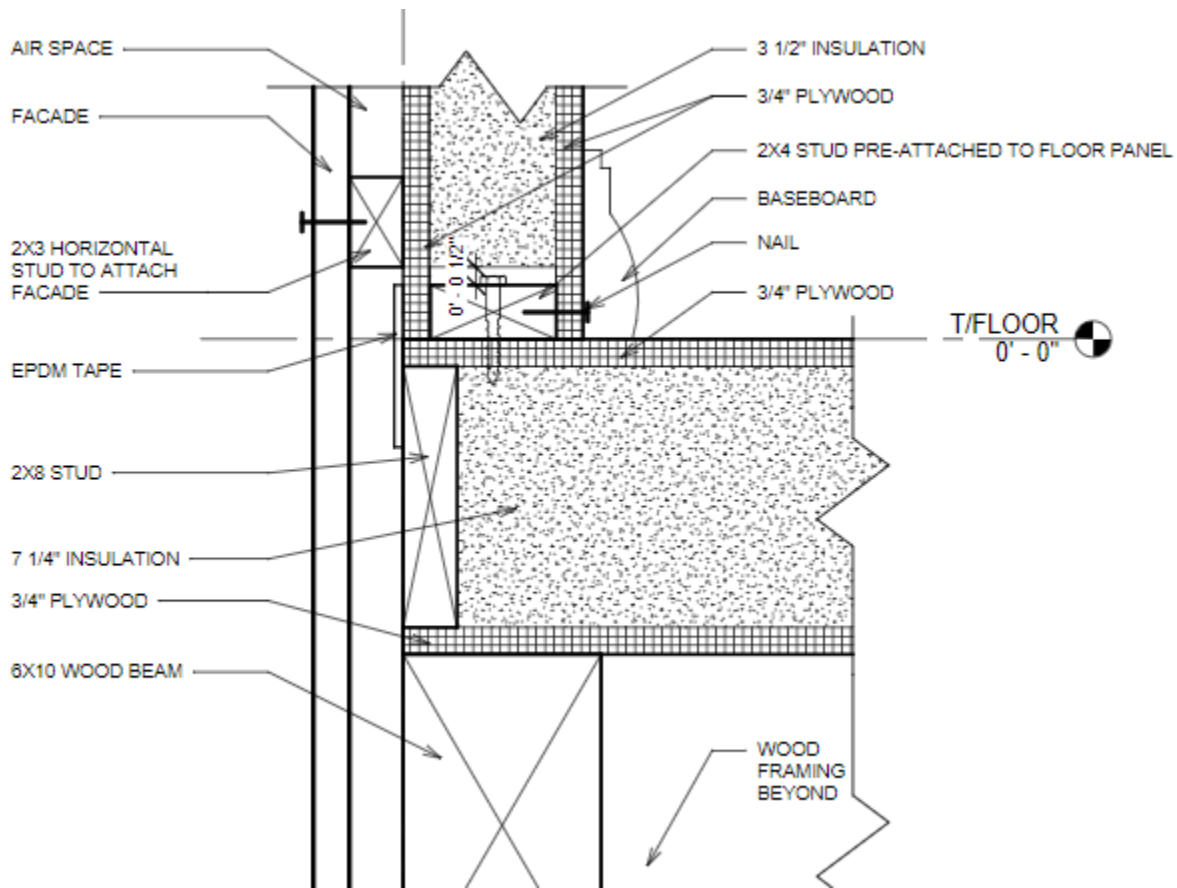

Figure 13: Exterior Wall System

Polystyrene was chosen due to its rigidity and thermal properties. For sandwich panels, a rigid foam insulation is needed in order to give the panel rigidity. Because of this, different types of rigid insulation were considered. Expanded polystyrene (EPS) was chosen because of its high thermal resistance value. EPS has an R-value of 3.6 per inch of insulation. For more details about this, see the mechanical section of this report.

Windows

Excluding the doors, all of the windows on the building are located near the top of the walls. This was for a few reasons. Typically, windows on houses in Morocco are extremely small or are very high up on the wall so that onlookers cannot see into the home. This promotes the privacy of home life that Moroccan people prefer. High windows and less glass surface area also helps with shading. In an extremely hot climate, it was important to consider sunlight and shading. With a latitude similar to Florida, the angle of the sun can often cause unbearable conditions in buildings. Raising the windows and minimizing the possible angles where too much sunlight can get into the building helps with keeping the building from getting too hot. High windows additionally allow natural lighting into the enclosure. Finally, high windows aid in natural ventilation. The cool air that comes in close to floor level through the cooling tower will rise as it heats up. The hot air then can escape from the high windows. The concept of natural ventilation through windows is portrayed below in Figure 14.

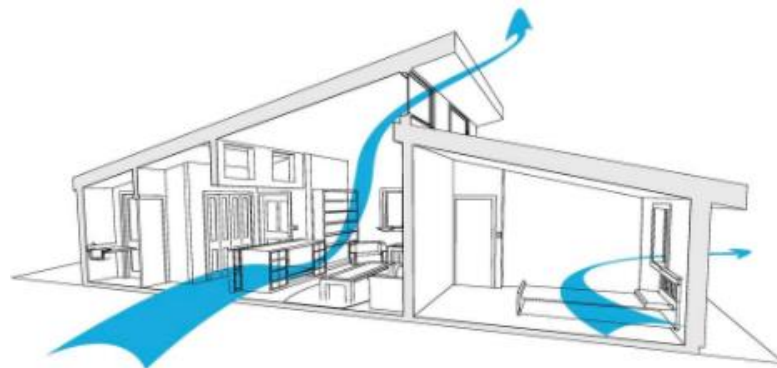

Figure 14: Diagram of Natural Ventilation Utilizing Stack Effect

The North and East facing walls both have 75 square feet of windows, amounting to about 20 percent of the total wall area. The walls on the inside of the "L" each have a sliding glass door, taking up about 20 percent of those wall areas as well. This amount of glass does allow a lot of heat transfer through the envelope (see section four for details), but the benefits of having natural light and an open-feeling space are substantial.

Roof

A sloped, corrugated steel structure that sits on the roof was designed so that rainwater would not pool on the flat roof. Corrugated steel was used because it is lightweight. Wooden posts were used so that the corrugated steel could be raised to a 3:12 slope, the minimum slope required for corrugated steel roofing. This extra layer of roofing was sloped toward the outside of the building so that water does not

pool on the decking area. It also allows future groups to implement a water collection system if desired. The roof construction is shown below in Figure 15.

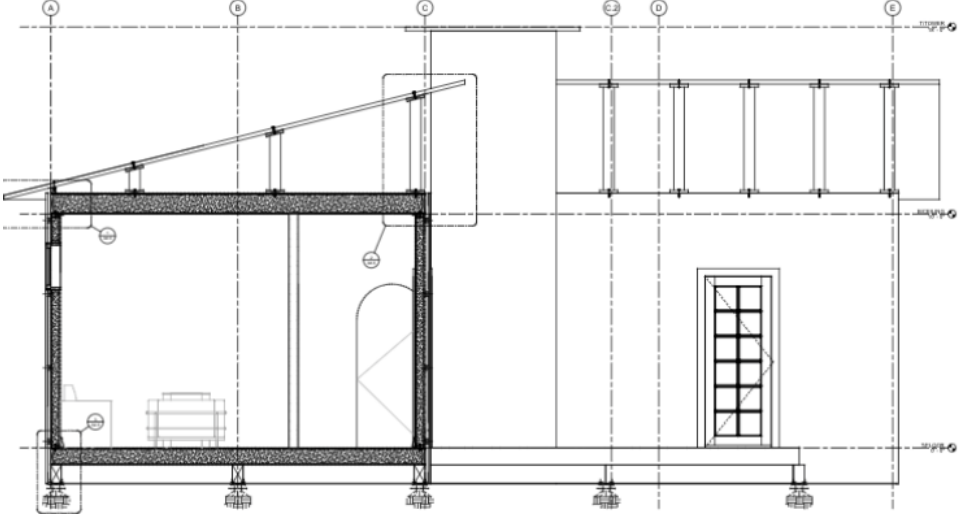

Figure 15: Section of the Building Showing Roof Construction

STRUCTURAL DESIGN

In the structural design phase, applied loads, sizing of members, framing configurations, and connections were all considered and analyzed. The structure was selected based on the following objectives:

- Constructability
- Cost
- Sustainability
- Cultural Context

The Solar Decathlon requires the house to be constructed by students within a period of one week. This means that the structure must be constructed in minimal time and by untrained construction professionals. Because of this, structural members could not be too large or heavy since the use of a crane is unrealistic or too cumbersome. Structural members should also fit together quickly and easily to expedite the construction process and make it as straightforward as possible.

It was also necessary to consider how the structural systems affect the overall cost of the project, as cost is a scored category in the Solar Decathlon competition. The house entered in the competition should be suitable for a mid-income family in the location of choosing. Because of this, there was a need to reduce the cost of materials needed, as well as the overall construction costs, to make the house as affordable as possible. This can be done by utilizing prefabricated pieces that do not require the use of trained construction professionals. Using materials that have low production and purchasing costs associated with them also aid the overall cost of the building.

Sustainability is a primary goal for the Solar Decathlon competition. As stated before, this competition is held to help promote a more sustainable lifestyle. This can be accomplished by incorporating more than just an efficient mechanical system. Using sustainable building materials can further aid in the overall sustainability of a house.

Finally, it was necessary to consider what systems are used or have been used in Morocco. Even though the Solar Decathlon is focused on innovation, the history and culture of the countries represented must be considered. Being conscientious of common structural practices and standards for Morocco prevents the design of a building that would seem out of place in the cities' landscapes.

System Selection

A structural system needed to be selected that would meet the four criteria: constructability, cost, sustainability, and history. Concrete, steel, and wood were considered for building materials. A table comparing each material can be seen below in Table 4.

Table 4: Comparison of Building Materials

	Concrete	Steel	Wood
Constructability	<ul style="list-style-type: none"> • Difficult to prefabricate and ship long distances • Heavier (machinery required) 	<ul style="list-style-type: none"> • Can be prefabricated • Requires expensive tools/ construction professionals 	<ul style="list-style-type: none"> • Can be easily prefabricated • Easier to construct without professionals • Lightweight
Cost	<ul style="list-style-type: none"> • Concrete itself is inexpensive • However, it can get expensive due to the reinforcement needed 	<ul style="list-style-type: none"> • Higher costs associated • Most expensive of the materials 	<ul style="list-style-type: none"> • Least expensive material for both materials and labor
Sustainability	<ul style="list-style-type: none"> • Environmentally friendly • Long lasting structures 	<ul style="list-style-type: none"> • Can be recycled and reused • Long lasting structures 	<ul style="list-style-type: none"> • Sustainable (if used from responsibly managed forests)
Cultural Context	<ul style="list-style-type: none"> • Very commonly used for both structural and architectural purposes 	<ul style="list-style-type: none"> • Not commonly used 	<ul style="list-style-type: none"> • Commonly used for structural frames within rammed earth buildings

With all the criteria in mind, wood was chosen as the material for the structure of the house. Wooden systems allow for a decent amount of flexibility in construction. By using wood, many pieces of the structure can easily be pre-fabricated. For many years, wooden trusses, panels, and sandwich boards have been pre-fabricated in shops and shipped to sites where they can be easily constructed. Wood is also a lightweight material which allows for construction without the use of cranes or heavy machinery. This will allow a small group of students to construct the structure without having to use expensive machinery. Wood is also a relatively inexpensive material. Because wood is readily available in Morocco, while structural steel may not be, a design with wood would be more marketable to those that live in these areas. Wood is also both sustainable and recyclable if it is taken from a responsibly managed forest. Because it is a naturally occurring material, wood that is used for the structure can be regrown and reproduced. Finally, houses Morocco are commonly wooden frame.

Loads

Loads represent the forces that structural members endure. Every structural member must be designed to withstand, at minimum, these forces. There are four major categories of loads need to be considered for this project: dead loads, live loads, wind loads, and seismic loads. A summary of the nominal values for each of these loads can be seen below in Table 5.

Table 5: Summary of Design Loads

Symbol	Load	Value	Reference
D	Dead Load	Weight of the member + finishes + 5 psf (Electrical)	Weight of elements
L	Floor Live Load	50 psf	Solar Decathlon Code
L _r	Roof Live Load	30 psf	Solar Decathlon Code
E	Seismic Load	645 lbs	ASCE 7-10 Chapters 11 and 12
W	Wind Load	27.6 psf	ASCE 7-10 Chapters 26 and 27

Dead Loads

Dead loads represent the permanent gravitational loads that a structure withstands. This includes the weight of all members, the supported structure, and any permanent fixtures attached to the building. Items included in this weight could be the beams, columns, roofing, and finishing.

The first major dead load that acts on the structure is the weight of the structural members themselves. For this building, all structural members are dimensional lumber and all sheathing is structural plywood.

The next category of dead loads that act on the structure are the weights of the mechanical, electrical, and plumbing (MEP) portions of the design. The MEP materials for this building were estimated at 5 psf. This is because the main mechanical system was implemented in the cooling tower only. The only loads that were present in the building for MEP systems were the electrical and plumbing systems.

The final category of dead loads includes the weight of the finishings on the building. For this design, the total dead load for the finishings was estimated to be 5 psf as well.

The total dead load that acts on members combine these two categories of dead loads. The values for the combined dead loads can be seen below in Table 6.

Table 6: Dead Loads (psf)

Category	Structural Members/ Finishes	MEP	Total Dead Load
Floor	10	5	15
Floor Panels	10	5	15
Roof	10	5	15

After design, the dead loads of each category were recalculated. After the dead loads were recalculated, members were evaluated using these dead loads instead of the assumed dead loads.

Members were adjusted if they could no longer support the loads. This process can be seen in Appendix A.

Live Loads

Live loads represent the occupancy and non-permanent gravitational loads on the building. These loads include the loads from people, furniture, and any movable or non-permanent fixture within the space. For competition purposes, this building is a residential space that will also be used for exhibition. Due to this classification of space, we were required to use the space constraint that has the highest live load to design members.

The live loads that were used for the design of this building were provided by the Solar Decathlon competition building code (Solar Decathlon Africa, 2018). They can be seen below in Table 7. These loads comply with the required minimum live loads presented in Table 1607.1 of the 2015 IBC.

Table 7: Live Load Requirement Summary

Load	Description
Interior Floor, Decks, Ramps	50 psf (2.39 kPa)
Exterior Floor, Decks, Ramps	100 psf (4.79 kPa)
Roof	30 psf (1.44 kPa)

Live loads do not only include those loads that are present when the building is completed and occupied. Construction live loads must also be considered. These loads represent the forces that the building undergoes during construction activities. Currently, working professionals use a construction live load of 25 psf. Because this value is lower than the occupancy load value, the structure was designed using the larger occupancy load.

Wind Loads

When wind hits a building, it effects the structure from both internal and external aspects. These effects create forces that depend on factors such as: building height, surrounding terrain, a buildings shape, the amount and size of openings a building has, and the location and size of the building. All these factors were considered when conducting the wind analysis for the building. Externally speaking, wind pushes on windward surfaces. This causes a suction effect on leeward surfaces and other additional surfaces. Furthermore, this can create positive or negative pressure inside a building. Overall this effect causes loading to be applied to a structure.

The process for performing a wind analysis on a structure involved using the codes and requirements provided to us by the Solar Decathlon competition in combination with Chapters 26 and 27 in ASCE 7-10. The Solar Decathlon code provides competitors with the information found below in Table 8.

Table 8: Wind Information as Provided by the Solar Decathlon Competition

	Information Provided
Exposure Category	C
Basic Wind Speed	115 mph

According to ASCE 7-10, exposure category C represents buildings that are in an open terrain with scattered obstructions having heights generally less than 30 feet.

For many reasons described later in this chapter, the building and the tower were analyzed separately. Because of this factor, wind loads were calculated for both the main structure as well as the PDEC tower. Both analyses utilized factors outlined in ASCE 7-10, which outlines the calculation procedure for wind loads acting on a Main Wind- Force Resisting System (MFWRs). This procedure first defines all the characteristics and parameters of the building’s location as it relates to the wind that acts on the structure. Because the tower’s height above the building was only 8 feet, the tower was considered a rigid structure and therefore used the same Wind Directionality, Topographic, Building Height, and Gust Factors.

After these factors were determined, analysis was completed for each wall of the structure and the tower. First, the basic velocity pressure was calculated using Equation 27.3-1 in ASCE 7-10. This value acts as a base number so that design wind pressure values can be calculated. The equation for this value can be seen below.

$$q_z = 0.00256 \times K_z \times K_{zt} \times K_d \times V^2$$

Once the base velocity pressure was calculated, the design wind pressures for the MFWRs for each wall were calculated using Equation 27.4-1 in ASCE 7-10. This equation can be seen below.

$$p = qG C_p - q_i(G C_{pi})$$

This equation was used due to the building’s classification as partially-enclosed and rigid. The design wind pressure was calculated for each wall, assuming that the wind direction was North. For design purposes, the final wind pressure was found to be 27.6 psf. The complete calculations used to find all the wind pressures can be seen in Appendix A.

Seismic Loads

Seismic loads occur when an earthquake effects a building’s structure. It is important to take these seismic loads into account when designing the structure of a building because they can produce large amounts of lateral stress on members. Because the structural designs for the building and the PDEC tower are separate, it is imperative to calculate the seismic loads on each structure separately as well.

There are many different steps that must be followed to calculate the lateral loads that result from seismic activity. First, it is important to determine the values associated with the site that the building is on as well as the categories related to the building’s occupancy and risk to human life. The important values here include the building occupancy category, spectral response acceleration parameters, site class, site coefficients, risk category, and seismic design category. The value for Seismic Design Category

(SDC), which is based on the values for S_{DS} and S_{D1} as well as the risk category was calculated to be SDC B by using ASCE 7-10, Table 11.6-1 and 11.6-2. This matches the SDC that was given by the Solar Decathlon Competition's code (Solar Decathlon Africa, 2018).

After these values are calculated, it is important to calculate how seismic forces interact the structure. System parameters were chosen based on the type of construction that was used to design the building. In this case, light frame wood walls with wood structural panels rated for shear resistance were used for the structural system. From here, the shear that acts on the base of the building was calculated.

The complete process for calculating the seismic loads that act on the building can be seen in Appendix A.

Structural Considerations

When designing structural members and connections, there are two different methods that can be used. These methods are the Allowable Stress Design (ASD) and Load and Resistance Factor Design (LRFD). Both methods can be used to produce similar results. After some research, our group decided to follow the ASD method to calculate the size needed for members. This is due to that while the LRFD method is efficient, there is a predominant use of the ASD method by industry professionals. According to Phillip Line, the Director of Structural Engineering for the American Wood Council, an unofficial poll was conducted during a February 2014 web seminar on the 2012 National Design Specification for Wood Construction (NDS). He stated that the responses were unanimous when he asked the question "do you predominately use ASD or LRFD provisions of the NDS?" All the industry professionals that were polled used the ASD method.

The proposed structural system consists of a frame to carry the transverse loads and a shear wall to resist the lateral loads. Each member of the frame works in conjunction to support the loads that act on them. Because of this, we needed to consider how the load transfers throughout the building. Loads transfer the supported forces from the roof supports, through the walls, into the floor supports, into the footings, and finally into the ground. With this load path in mind, we determined the best way to design the structural frame so that it may withstand the loads applied while also remaining easily constructible. This building's structural frame consists of adjustable footings, beams that support structural floor panels, structural wall panels, and structural roof panels.

Beam Design

Beams are needed to support the floor's structural panel system. These beams provide a grid which the structural panels can sit atop and act as a base diaphragm for the entire structure. The structural beam plan can be seen below in Figure 16.

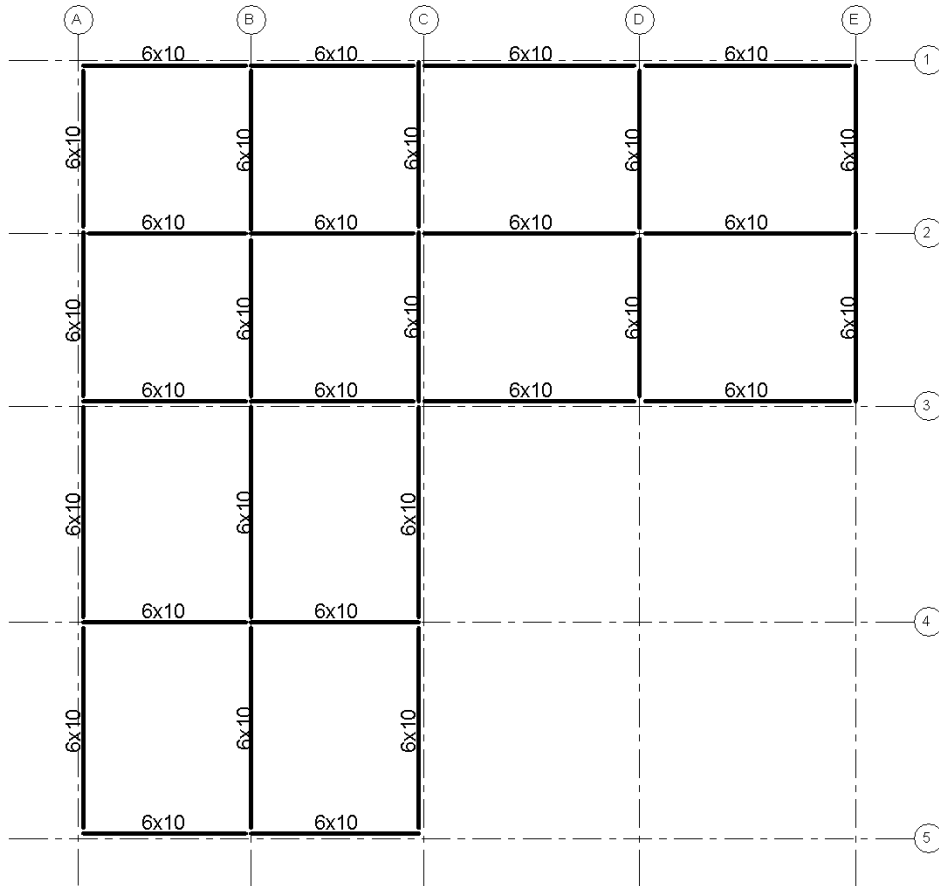

Figure 16: Beam Framing Plan

To begin the design of these beams, the length and tributary width of each beam determined. The tributary width is defined as the distance to either side of the member that it supports. In this case, this tributary width is half of the distance to the next beam on each side. From there, it was necessary to find the tributary area of the beam. This can be found by multiplying the value for the tributary width by the length of the member. The values for tributary width and area are important because the beams must be able to support the dead and live loads that act on that width or area. A visual representation for the tributary width of a beam can be seen below in Figure 17.

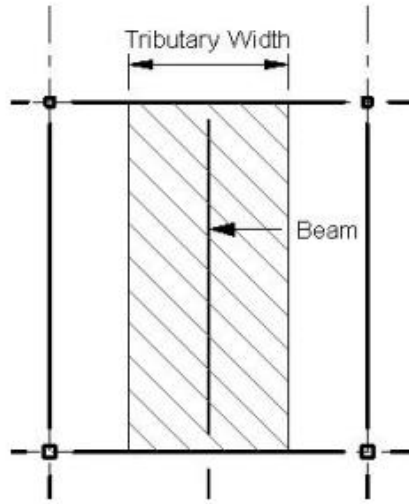

Figure 17: Tributary Width of a Beam

For this building, the transverse loads that act on the floor beams would be the weight of the structural members in addition to the interior floor live load of 50 pounds per square foot (psf), previously described in the Live Load section of this report. Therefore, when analyzing these members, the loads should be added together to get the total load that is acting on them. In allowable stress design, the dead loads and the live loads used for horizontal members are added equally according to the 2015 International Building Code. This is because the combination of the dead load and the live load represent the highest load acting on the floor system. The total design load for the floor is 65 pounds per square foot as stated below.

$$D + L = TL$$

$$50 \text{ psf} + 15 \text{ psf} = 65 \text{ psf}$$

Once the total design load is found, the bending moment and shear forces in the member are calculated. Bending moments occur when a beam withstands forces that cause a bending effect along the length and causes stresses in the beam. Shear forces occur when forces are applied along the surface of the beam. Both bending moments and shear forces can be tolling on a beam's strength. Many times, in design of structural beams, bending moment and shear force are the largest factors influencing the beam and are therefore the deciding factors for size and strength.

Next, the allowable stresses for the beam should be calculated. The reference stresses for bending and shear can be found in the 2005 American Wood Council (AWC) National Design Specification (NDS). The values given by the NDS are tabulated for normal conditions. In order to find the allowable stresses, these values should be multiplied by a number of correction factors that represent the conditions that the beam is in.

Next, the allowable deflection of the beam must be calculated. Deflection is an important factor to calculate because it represents the maximum amount that the beam is allowed to displace vertically based on the length and the loads it withstands. The deflection for both the live load and total load cases are required. According to the 2015 International Building Code, for the live load only, the allowable

deflection is limited to the length of the beam divided by 360. For the total load case, the allowable deflection is limited to the length divided by 240.

Next, the required section modulus, moment of inertia, and cross-sectional area of each member can be calculated. Each of these values represents the required section properties for the lumber used for the beam. The calculated section modulus, moment of inertia, and cross-sectional area are compared to the sectional properties of standard size lumber using Table 1B in the 2005 NDS. The lumber that best meets each of these requirements is the optimal size for the member.

The final step was to compare the actual deflection of the lumber to the minimum deflection requirements. The deflection of the member must be less than the length of that member divided by 360. If the deflection calculated is less than the length divided by 360, then the member is acceptable. If it is greater than this value, then a larger member must be selected. An example of this calculation can be found in Appendix B.

When the calculations for the sizing of the floor beams were finished, it was found that there were many different dimensions for timber. Because each beam carries a different tributary area, the required members were all slightly different. However, having many different member sizes would be more confusing and time consuming for those that construct the building than if all the members had the same cross-sectional area. In order to have the most constructible design, members were adjusted to a member size that work universally for all. The largest member calculated required a 6 x10 piece of dimensional lumber. Therefore, all members were adjusted so that 6 x 10 lumber was used throughout the flooring beams. The other beam sizes could be increased to match this beam because there would be no loss of strength. The optimization process for choosing the beams can be seen below in Table 10.

Table 9: Member Size Optimization

Member Classification	Original Member Size		Final Member Size
8 Foot Interior (80 ft ² TA)	6 x 8	→	6 x 10
8 Foot Exterior (40 ft ² TA)	4 x 8	→	6 x 10
10 Foot Interior (80 ft ² TA)	6 x 10	→	6 x 10
10 Foot Exterior (40 ft ² TA)	4 x 8	→	6 x 10

Structural Panels

Structural Panels are incorporated into the design for constructability purposes. As stated before, the competition takes place over the course of one week. This means that this building must be constructed on site in a very short period of time. Because of this, it is easier to travel to the competition with modular, prefabricated pieces that can be constructed quickly and easily. The team’s solution to this is designing structural panels made from dimensional lumber and plywood sheets. These panels would be created here in the United States before all the competition materials are shipped to the competition’s Morocco location. Structural panels will be used for the flooring, walls, and roof components of the building. Floor panels will sit atop the floor’s beams. A 3-Dimensional representation of these structural

panels can be seen below in Figure 18. The image to the left shows the panel without the plywood sheathing so that the members can be seen easily. The image on the right shows the panel as a finished product with the plywood sheathing.

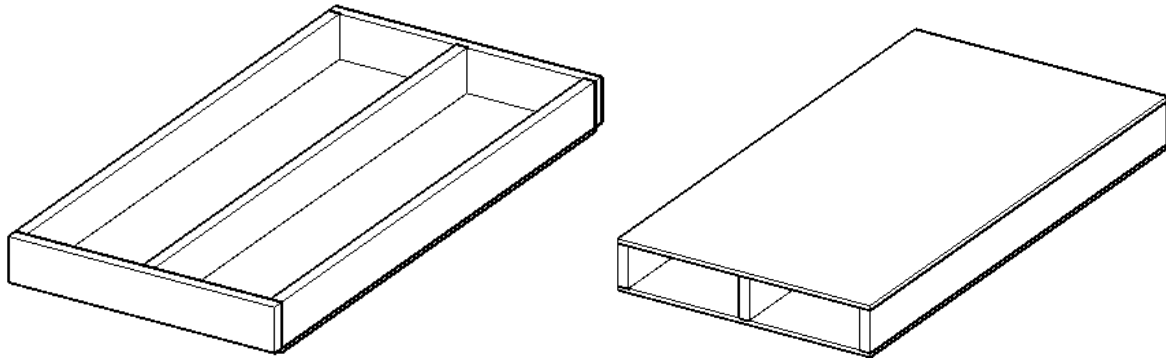

Figure 18: 3-Dimensional Representation of Structural Panels

Floor Panel Design

In order to have panels that easily fit into the floor frame that the beams created one standard panel was designed. The standard panel is 4 feet in width and 16 feet in length. The panel sizes were chosen due to a few factors. Firstly, plywood comes in standard sheet sizes. Commonly, these sheets are 4 feet in width and have a standard length of 8, 10, or 12 feet. In order to not have to cut or reshape these sheets of plywood, the panels were designed so that two standard plywood sheets could cover each side of the panel. These dimensions also worked with the beam plan so that 15 of the same sized panels could be used. This creates more ease in construction because each panel is the same, meaning that the location where they are placed is not important. The floor panel framing plan can be seen below in Figure 19.

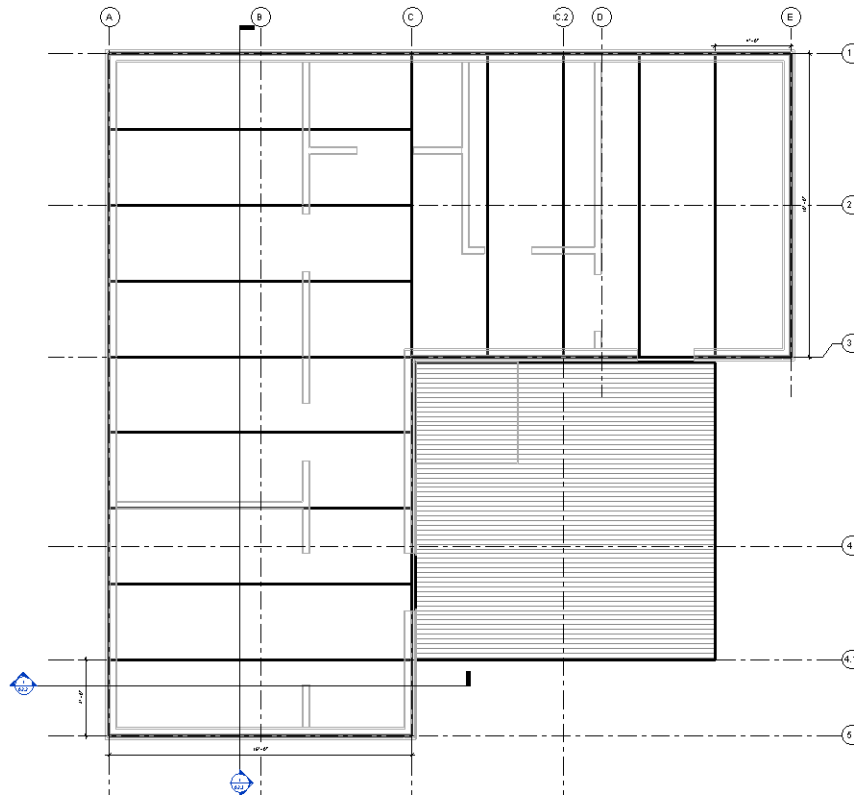

Figure 19: Floor Panel Framing Plan

The loads that act on these floor panels include the dead load of the structural members as well as the floor live load. These values are the same as the floor beams because they support the same members above them. The total loads can be seen below in Table 11.

Table 10: Design Loads Acting on the Floor Panels

Load		
Live Load (LL)	50	psf
Dead Load (D)	15	psf
Total Load (w)	65	psf

The beams that give the floor’s structural panels stability were designed using the same methods as described in the “Beam Design” portion of this report. These calculations resulted in sawn lumber joists that had 2 x 8 nominal dimensions. For the full calculations, refer to Appendix B.

After calculating the beam sizes that are required within the panels for both the flooring and roofing, structural calculations were required for the plywood flooring that is used on each exterior face of the panel. For the flooring, the joists provide the structural stability to withstand the gravity loads that act on the panels. The plywood sheathing also provides rigidity and structural strength. They must also adhere to the 2005 edition of the American Wood Council’s Allowable Stress Design Manual for Engineered Wood Construction. For the loads and spans that the plywood for the flooring withstands, 3/4” plywood is the most optimal size. This is limited by the span rating as given by the AWC.

20. A visual representation of the floor panels including member sizes can be seen below in Figure

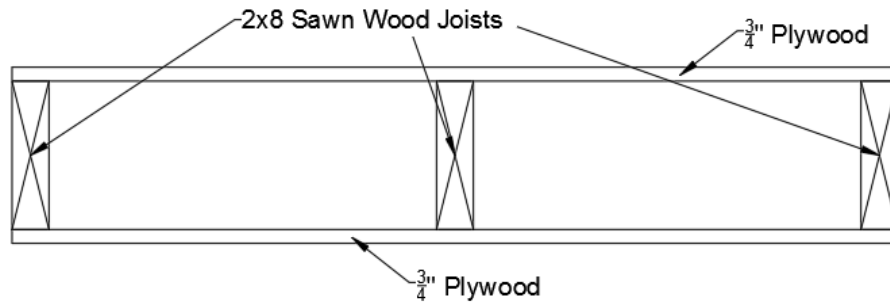

Figure 20: Floor Panel Section

Roof Panel Design

The structural panels that make up the roof are similar in size and shape to the floor's structural panels. The design calls for fifteen 4-foot by 16-foot panels that span each length of the building. The framing plan for these panels is the same as it was the flooring. It can be seen below in Figure 21.

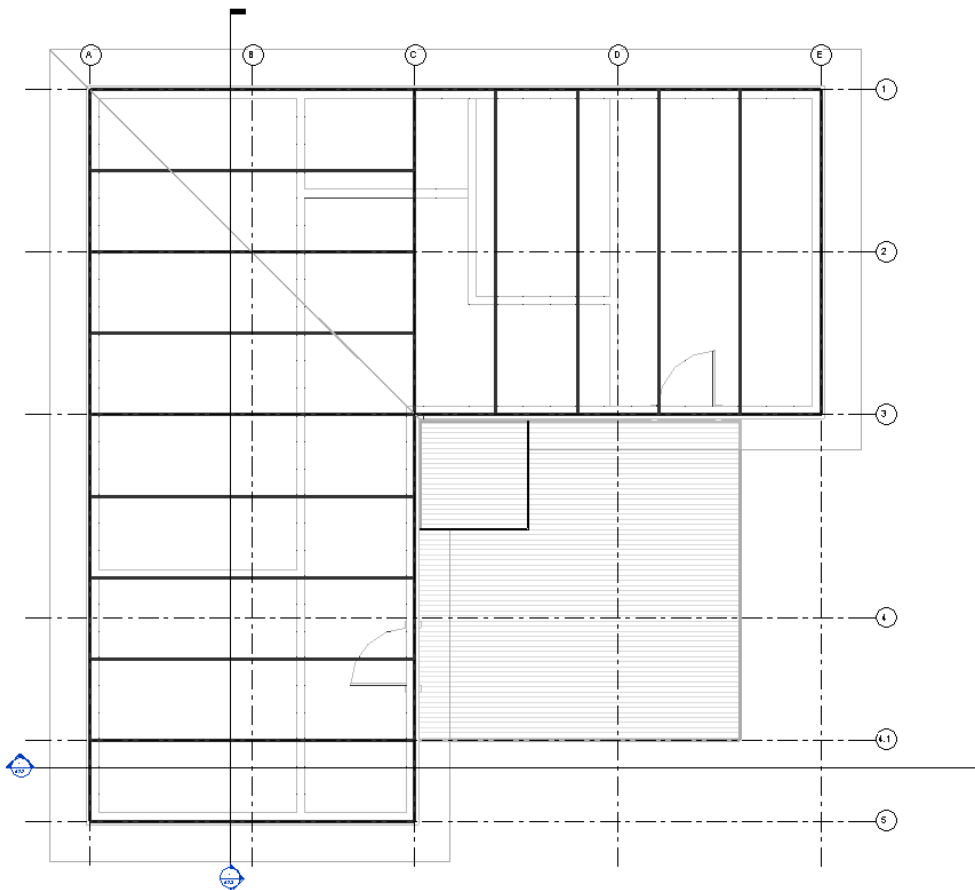

Figure 21: Roof Panel Plan

The loads that act on the roof members include the dead weight of the structural members as well as the roof live load that was provided by the competition. The total load acting on these members can be seen below in Table 12.

Table 11: Design Loads Acting on Roof Members

Load		
Roof Live Load (L_r)	30	psf
Dead Load (D)	15	psf
Total Load (w)	45	psf

For these panels, the calculations resulted in sawn lumber joists that had 2 x 10 nominal dimensions. The plywood was sized in the same way as for the flooring. The plywood required for the roof was $\frac{3}{4}$ " thick and was limited by the span rating as well. These calculations can be seen in Appendix B. A visual representation of the roof panels including member sizes can be seen below in Figure 22.

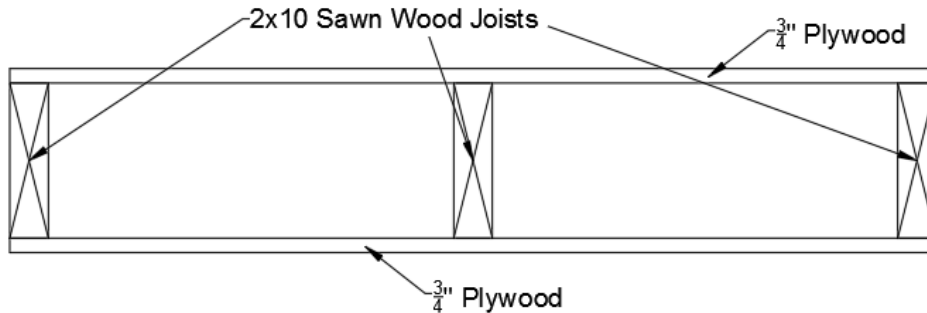

Figure 22: Roof Panel Section

Wall Panel Design

As stated before, the exterior walls for this house were designed using sandwich panels. These panels are made from two sheets of plywood with a rigid insulation between them. The plywood sheets give these panels strength while the rigid insulation keeps the panel together. The sandwich panels are connected to the roof panels through a top sill that is pre-attached to the panel. An example of this top sill can be seen below in Figure 23. It is outlined in red and labeled “2x4 stud pre-attached to the roof panel.”

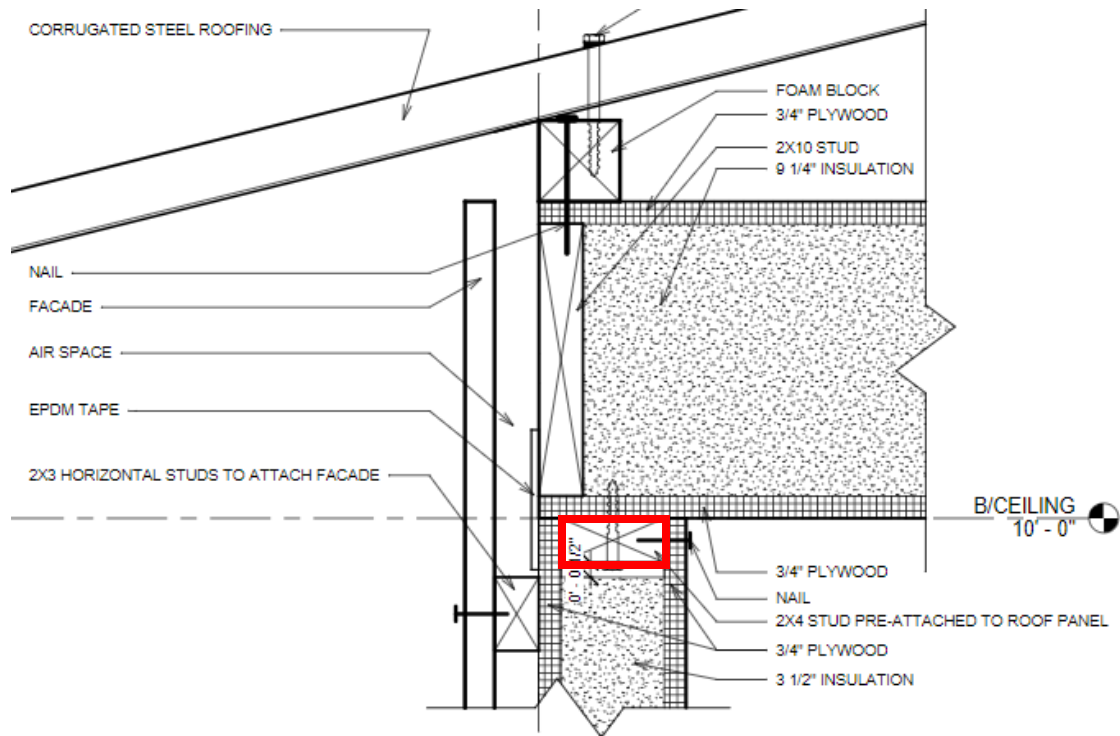

Figure 23: Wall Section Including Top Sill

In order to design these panels for the walls, the reactions from the beams that directly sit atop the walls should be calculated first. This represents the loads that transfer directly from the roofs through the walls. The next value that we needed to find was the unbraced height of each vertical member. This is the height that the vertical member spans without any lateral bracing. Because the floor and the roof acts as lateral bracing for the vertical members, the unbraced height is the floor to ceiling height. For this house, the floor to ceiling height is 10'-0".

This means that the vertical members must support the weight of everything above it. Therefore, the roof load must be considered when calculating the total load on the vertical members. Loads were transferred from the roof of the building to the walls by dividing the load by the perimeter of the building. The loads that act on the vertical members in exterior walls can be seen below.

Table 12: Example Loads that Act on Exterior Wall Members

Load		
Roof Live Load (L_r)	30	psf
Dead Load (D)	15	psf
Total Load (w)	45	psf

PDEC Tower Design

The PDEC tower is the central focal point of the architectural and mechanical designs of this home. In the interest of marketability, the tower was designed as a separate structure that can be implemented into buildings with similar sizes and cooling requirements. This means that the structural

members in the PDEC tower must be calculated using its own loads. Live loads such as wind or seismic loads and dead loads were calculated separately from the rest of the building.

The structure of the PDEC tower consists of two pre-fabricated boxes created from dimensional lumber. These boxes will then be constructed together during the competition in order to create the structure of the PDEC tower. A visual representation of these boxes can be seen below in Figure 24.

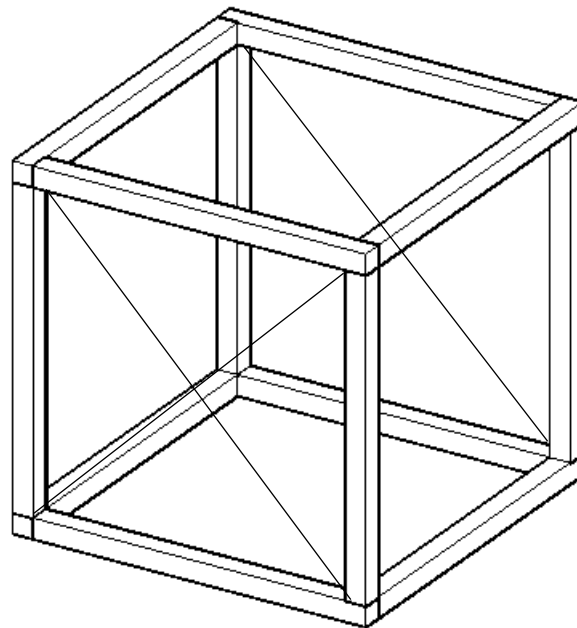

Figure 24: Structural Box for PDEC Tower

The vertical members in the boxes were designed using the procedure for the design of wood columns. Horizontal supports were designed as though they were beams.

Because the PDEC tower will be subjected to large amounts of wind due to its height, lateral bracing was needed in order to provide resistance. Steel cable ties were chosen as the main lateral support for the tower's structure. These ties, arranged in an x on each side of the tower, act as lightweight cross bracing for the tower. These ties, arranged in an x on each side of the tower, provide lightweight cross bracing for the tower.

Adjustable Footings

Due to the time constraints of the competition, the house is a non-permanent structure while it is constructed. Excavation into the ground and the use of traditional concrete footings or slab foundations are not permitted for the competition. Therefore, a more innovative foundation must be implemented in order to combat this issue.

We will also be going into the competition with very little knowledge about the surface patterns and topography of the area. The Solar Decathlon rules state that there may be a vertical elevation change of up to 10 cm that exists (Solar Decathlon Africa, 2018). Topography maps are provided to competitors

once teams are selected. Because the site cannot be guaranteed flat, adjustable footings with built in tolerance for possible uneven sites must be used.

In order to select an adjustable footing, the total weight of the building was found. This includes the weight of all dead loads and live loads that act on the structure. The total weight of the building that was designed was 19,400 lbs. In order to choose the appropriate footings for this building, the weight that is supported by each footing should be considered. This is done by taking the total weight of the building and dividing it amongst the tributary area of each footing. The footings must be optimized for the footings that withstand the most weight. Therefore, the footings on the interior of the structure are the limiting factor.

After considering the amount of weight on each footing, a footing type was selected. For this building, anchor plates with an adjustable screw that is screwed into the foundation beams will be used. An example of this type of foundation can be seen below in the Figure 25 below.

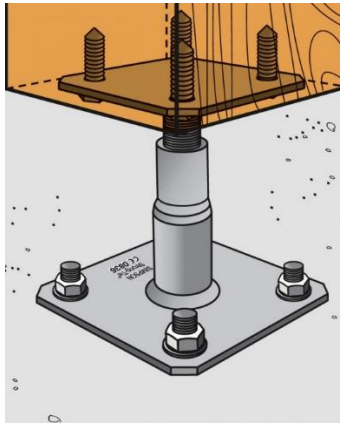

Figure 25: Example of Adjustable Foundation Using Steel Plates and Screws from Simpson Strong-Tie

RISA Modeling

After the structural system was designed through hand calculations, RISA 3-D was used to accurately model the effectiveness of the structural system. RISA is a structural engineering software that simplifies the analysis and design of structures. By using this software, it was simple to look at the requirements and limits of each structural member and how loads affect them.

Each of the structural systems were analyzed separately. This means that the floor beams, floor panels, wall panels, roof panels, and tower structure were analyzed in separate files in the software. However, loads were transferred between files so that there were accurate depictions of each system.

Overall, the results from the RISA models determined that the structural members designed were sufficient. The results from each of these analyses can be seen in Appendix C.

MECHANICAL DESIGN

Comfort is key when designing any mechanical system for a living space. In our building, a passive downdraft evaporative cooling system provides cooling to reduce electricity use compared to traditional cooling systems and an insulated building envelope to reduce heat flow into the building. The climate in Morocco allows for the effective use of direct evaporative cooling during the dry season due to the high temperatures and low levels of humidity. During the highest temperatures of the year, the tower would be incapable of cooling the building to our target temperature of 77°F without help from a supplementary system. In North America, a region with a similar climate to Errachidia is central Texas.

Thermal Comfort

The concept of thermal comfort is an essential part of a successful building design. Unlike the United States, there are no generally accepted thermal comfort standards for Morocco. Elsewhere in the world where ASHRAE guides thermal comfort standards, the typical "neutral" indoor temperature for the summer is 77°F. For the winter, it is 72°F. While these numbers provide a guideline, climate and cultural differences from region to region must also be considered. For example, air conditioners are a commonality in American homes, but in Moroccan homes they are a rarity. Instead, natural ventilation and fans are a more common occurrence. The Solar Decathlon follows the conditions specified by ASHRAE. The interior dry bulb temperature should be kept between 72°F and 77°F. The relative humidity should fall between 45% and 55%.

Load Calculations

The temperature in Morocco exceeds 95°F in the summer and can occasionally drop below 40°F during the winter. While we focused on cooling the building passively, we also had to consider ways to keep it heated during cold winter nights.

Cooling Load

The cooling load for our building was calculated using the CLTD/CLF calculation method. This method allows for an approximation of the total heat gain in the building based on thermal resistance values for the building envelope. The materials used in the walls, roof, and fenestration are all accounted for independently. This method takes into account the outside air temperature, latitude, and time of day to provide an accurate estimate of both transmission heat gain and solar heat gain¹.

Thermal Resistance of Envelope

Figure 26 is a plot of heat gain through the walls as a function of the thermal resistance of the walls.

¹ A full explanation of this method can be found in the ASHRAE cooling and heating load calculation manual (1979) or by doing an internet search and following a reliable source.

Heat Gain Through Walls (BTUH)

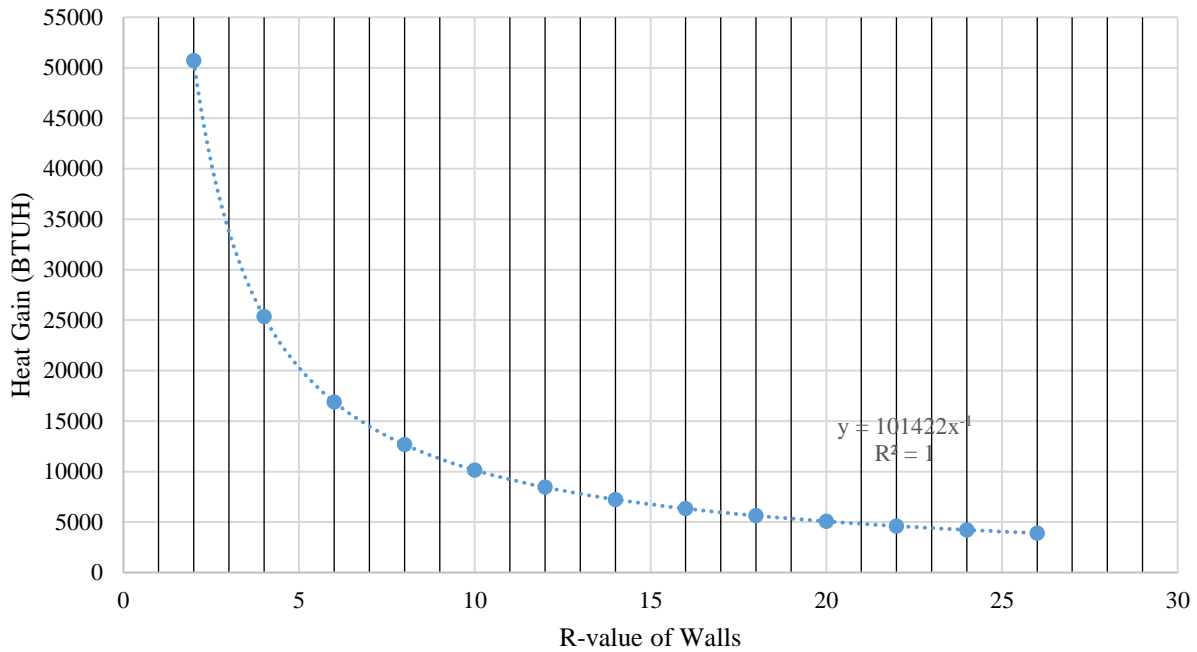

Figure 26: Peak heat gain through walls as a function of R-value

The knee of the curve is the section that guides the choice of wall insulating value: R-values to the left allow a very high heat gain, and values to the right are decreasingly effective as they increase. The sweet spot, for our building, is an R-value between 9 and 14. With this in mind, we decided on a wall construction with an R-value of 12.8. This is based on a standard thickness of 3.5 inches for the insulation material. The R-value used for the roof is 24.5. The roof value was determined based on the required thickness of the roof as specified by the structural calculations as opposed to the insulation requirements. The breakdown of the wall and roof R-values can be found in Appendix E. For the windows we used thermal properties for standard double pane glass.

Peak Cooling Load

Once again using the CLTD/CLF method, this time varying the date and time, we determined that the peak loads occur during the month of June, around 5pm. In general, mechanical systems are designed so that they can handle the heating and cooling requirements during the coldest and hottest hours of the year, respectively. Table 14 shows the breakdown of transmission gain, solar gain, and internal gain during the hottest hour of the year. The total BTUH per square foot was 26.4, which is very similar to what a similarly sized house in the southern United States would experience.

Table 13: Peak Cooling Load Breakdown and BTUH per square foot of floor area

Month	June	
Time	1700	
	Transmission Gain (BTUH)	BTUH/sqf
Walls	2214	2.7
Roof	876	1.1
Windows	2394	2.9
	Solar Gain (BTUH)	
Walls	1462	1.8
Roof	2572	3.1
Windows	8058	9.8
	Totals	
Walls	3676	4.5
Roof	3447	4.2
Windows	10452	12.7
Internal	4222	5.1
All	21797	26.4

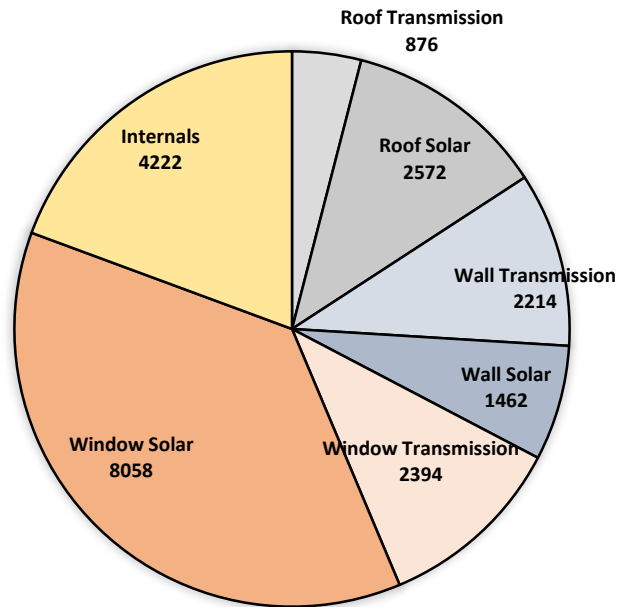

Figure 27: Peak Cooling Load Breakdown

This table shows that almost half of the required cooling is a result of heat gain through the windows. It is typical for windows to be a high contributor to heat gain in a building because they generally have low thermal resistances and let sunlight directly into the building. In every building there

is a balance between allowing natural light into the building and reducing heat flow through the envelope. Our building reflects what we thought was an appropriate middle ground.

Heating Load

While it does occasionally get cold enough to warrant a heating system in Errachidia, it is only during cold winter nights. The peak heating load during the year is 10400BTUH, but it drops to 6000 when internal heat gain is accounted for. The heating load over the course of a winter is around 1400kWh when accounting for internal gain, or 3500kWh if no internal gain is assumed.

Evaporative Cooling

Evaporative cooling is a method of lowering the dry bulb temperature of air by increasing the relative humidity. This works because of the latent heat of vaporization of water. Energy is required to evaporate water, so energy as heat is transferred to energy that is used to evaporate the water. The result is that the temperature of the air drops as the relative humidity increases. Also known as swamp cooling, this method is particularly effective in climates that experience low humidity levels. Figure 28 shows the general psychrometric process of evaporative cooling and how the humidity increase does not exceed the comfort standard. The value labeled 1 represents the psychrometric value of the outside air, 2 is the supply air, and 3 is the indoor air conditions.

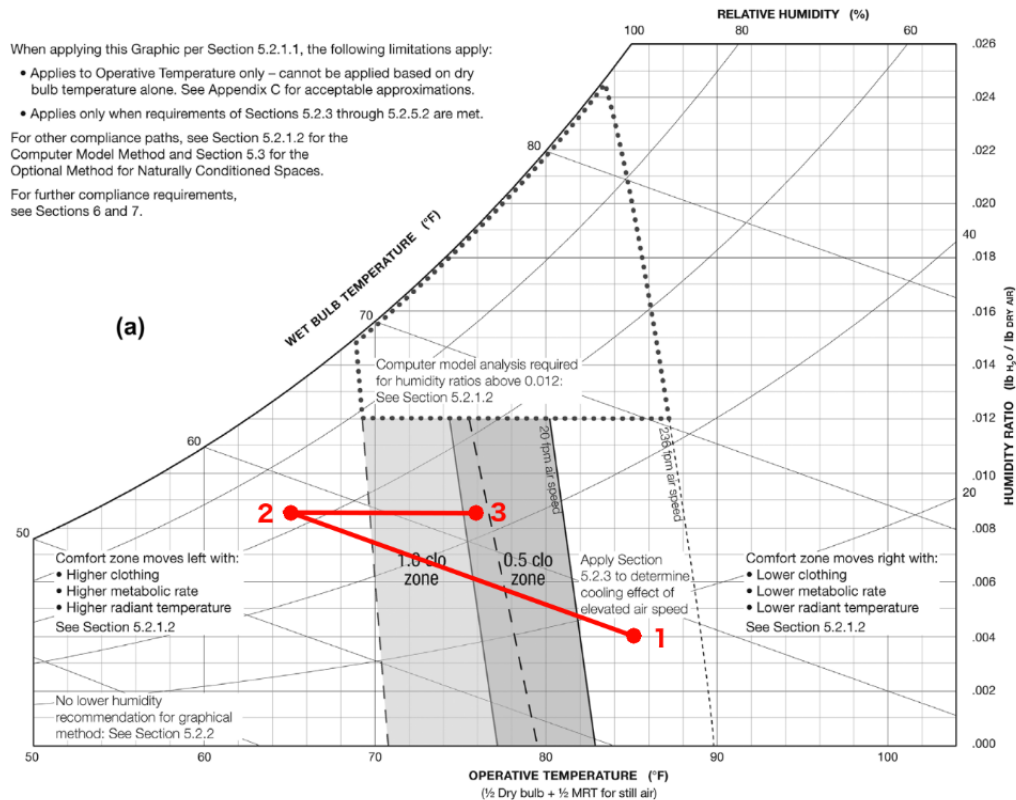

Figure 28: ASHRAE 55 Comfort Chart

Passive Downdraft Evaporative Cooling

Passive downdraft evaporative cooling towers are derived from wind towers commonly used in the Middle East. They capture hot and dry outside air at the top and cool it by humidification before expelling the air at the bottom. These towers are often tall (30 feet or higher) and have a mechanism near the top of the tower (where air enters) to humidify the air. The two most common methods are by sprayer and by pad.

Sprayers add droplets of water to the air that fall and evaporate in the tower. Water that does not evaporate is collected at the bottom and recycled. Water is pumped to the top of the tower and forced through nozzles that control the size of the water droplets. Larger droplets take longer to evaporate but require less water pressure. These type sprayers are well suited to taller towers or towers that double as a water feature. Smaller droplets require less time to evaporate fully, but require more water pressure. These type sprayers are better suited for shorter towers (such as ours) or when a higher rate of evaporation is desirable.

Pads are simply cloth pads that are kept damp so that the air is humidified as it passes over and through them. Water can be pumped to the pads so that they are constantly kept damp, or the pads can be routinely removed and soaked before being replaced, eliminating the need for a pump but requiring regular access to the pads. Pad type cooling is well suited to large towers where the pads have a large surface area to contact the air and the building does not need a high rate of airflow.

For our design we opted to use a sprayer type humidification system. Because our tower is fairly small, we wanted to be able to control the droplet size so that we could maximize the rate of evaporation. Airflow through the tower is achieved by the density difference between the dry air and the humid air pulling the air downwards. A typical density difference in the summer is 0.00085 lb/ft³. Many towers also utilize wind catchers to increase the amount of air into the tower.

Ventilation of Air & CFM Values

When the tower is operating passively, airflow is achieved via pressure difference between the air at the top of the tower and the air at the bottom. This is the same way that air flows through a chimney, only in reverse: in a chimney, warm air rises; in an evaporative cooling tower, cool, moist air falls. As a result, the equation for calculating draft in a chimney can be reapplied to quantify the driving force for airflow in a passive downdraft evaporative cooler (PDEC). The theoretical draft in a chimney, according to the ASHRAE Equipment Handbook (2016, pp 35.7), can be determined as follows:

$$D = 0.2554 \times B \times H \times \left(\frac{1}{T_o} - \frac{1}{T_m} \right)$$

D = theoretical draft in inches of water

B = ambient barometric pressure in inches of mercury

H = chimney height in feet

T_o = ambient air temperature in °R

T_m = mean flue gas temperature in °R

This equation converts temperature difference into pressure difference. In a chimney, temperature difference is the only source of density difference. In a PDEC, both temperature and humidity contribute to the driving force density difference. Solving the chimney equation for a variety of pressure differences using a constant B and H, yields a relationship between theoretical draft and the pressure difference (instead of temperature difference). We used 29.92 inches of mercury for the barometric pressure and 18 feet for the height of the tower. The updated equation for our purposes is as follows:

$$D = 0.00643 \times B \times H \times dp$$

$dp = \text{density difference across the tower}$

To determine the possible airflow through the tower, we used normal summer conditions:

- 95°F @ 25RH has a density of 0.07672 lb/ft³
- 73°F @ 75RH has a density of 0.07757 lb/ft³

This means that our pressure difference is 0.00085 lb/ft³, so our theoretical draft works out to be 0.00294 inches of water. In order to find the airflow from here, we need to determine how much of this pressure is velocity pressure and how much is lost to friction. To determine the friction, we use a similar process as before to find a relationship between air velocity and head loss. Using a ductulator to plot values and Excel to find a line that describes the data, we determined that the relationship between airspeed and head loss is as follows:

$$H = (1.763E(-8) \times v^2) + (3.715E(-6) \times v)$$

Where H is the head loss per 100 feet and v is the air velocity in feet per minute.

From here, we know that the theoretical draft is equal to the velocity pressure added to the head loss. The head loss also must be adjusted to account for fittings and obstructions. In addition to the normal head loss through the duct, we are using a coefficient of 1.75 to account for two bends in the airflow path and an obstruction in the form of the sprayer nozzles. Velocity pressure can be written as a function of velocity, allowing us to write an equation solely in terms of velocity which can then be solved:

$$D_t = VP + H$$

Substituting the values that we solved for above and correcting for fitting losses, the equation becomes

$$0.00294 = 1.75 * \left(\frac{v}{4005}\right)^2 + \frac{18}{100} * (1.763 * 10^{-8} * v^2 + 3.715 * 10^{-6} * v)$$

By rearranging the equation, it can be solved as a simple quadratic equation, and we find that the velocity achieved by the given theoretical draft is 157 feet per minute. With a tower cross section of 25 square feet, this yields a volumetric flow rate of 3925 cubic feet per minute. This volume of air is not feasible throughout the house due to walls and other obstructions, but it is reasonable to achieve 2000CFM. This volumetric flow rate would limit the indoor airspeed to approximately 20 feet per minute (0.1 meters per second), which is a comfortable maximum indoor airspeed, so all further calculations were done with the assumption that airflow is restricted to 2000CFM for comfort.

Tower Performance

Givoni (1996) studied the shower method of evaporative cooling and found that in towers of three meters or higher, the air is generally humidified to 75 percent or more of the total possible saturation. Because of this, we used 75 percent efficiency to determine the performance of our tower.

Table 15 shows temperatures throughout the year and their average coincidental relative humidities².

Table 14: Yearly Temperatures, Average Relative Humidities, and Incident Required Cooling

				Cooling required
Temp C	Temp F	Hours/yr	Avg RH	BTUH
40	104	48	15	22000
38	100.4	136	20	20500
36	96.8	223	21	19500
34	93.2	276	24	17500
32	89.6	343	27	16000
30	86	341	29	15000
28	82.4	425	32	13500
26	78.8	445	37	12000
24	75.2	466	40	10500
22	71.6	526	44	9000
20	68	612	51	8000
18	64.4	1085	53	6500
16	60.8	644	60	5000
14	57.2	597	66	3500
12	53.6	529	74	2390
10	50	485	75	1226

Based on the maximum airflow that was calculated above (3925 CFM), the tower can function passively when the outdoor air is 96.8°F and 21%RH. Table 16 shows the CFM required for each temperature bin so that the building interior is kept at 77°F.

² Hourly temperature and humidity data was retrieved from OpenWeatherMap and is an average based on hourly data from January 2012 to December 2017

Table 15: Required CFM for Various Temperature Ranges

Temp C	Temp F	Required CFM
40	104	-
38	100.4	18636
36	96.8	3545
34	93.2	5303
32	89.6	2424
30	86	1948
28	82.4	1364
26	78.8	909
24	75.2	682
22	71.6	545
20	68	428
18	64.4	295
16	60.8	207
14	57.2	133
12	53.6	80
10	50	37

This shows that the highest temperatures require very high CFMs to maintain the interior temperature that we want, but for any outside temperature below 86°F the tower only needs to provide at most 2000CFM of air into the building. There are 7180 hours per year that our house needs cooling, and for 6155 of those hours (85%) the tower can operate passively while maintaining a reasonable indoor airflow.

Water Consumption

Using the temperature ranges above and assuming an effectiveness of 75% for humidification, we determined the amount of water the cooling tower requires per hour at each temperature range. This is shown in Figure 29.

Water Usage for Temperature Ranges

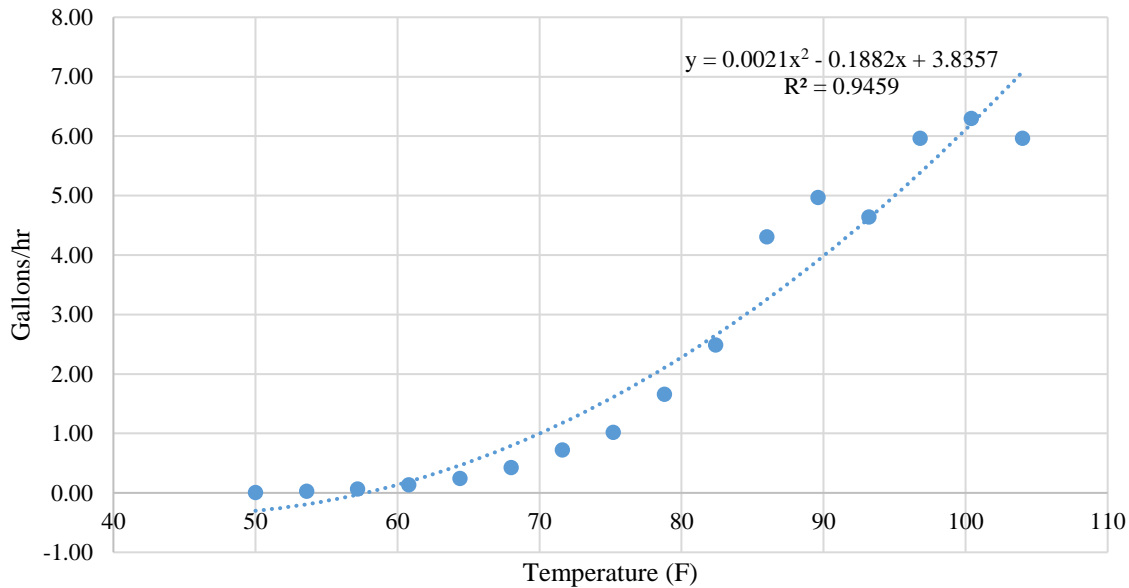

Figure 29: Water Usage

As one might expect, higher temperatures mean more water is needed to cool the air. This graph assumes that any airflow is restricted to 2000CFM at most, meaning that the highest temperatures are not passively cooled to the target interior conditions. This was chosen because at higher temperatures, the airflow required is unsustainable. Using these numbers and taking into account the frequency of each temperature range during the year, the average water consumption needed for cooling is 1.62 gallons per hour, which is about what is needed when the outdoor temperature is 77°F based on the chart.

Supplementary Cooling System

A supplementary system will need to be incorporated into the design for it to be effective when the outside air is either too hot or too humid to be passively cooled to the desired indoor temperature. The tower can function passively up to around 86°F, but at higher temperatures the air being taken in should be cooled to a point where the tower can do the rest of the work. One possible solution is a cooling coil near the intake of the tower. One major benefit from such a system is that it would allow for a lower CFM through the tower and could lead to less water used to humidify the air. The downsides are the energy costs associated and the difficulty of such an implementation within a solar house. Table 17 shows the cooling requirements of such a coil and the yearly effectiveness of the system with this addition.

Table 16: Impact and Requirements for a Supplementary Cooling System

Outdoor Temperature (F)	Target Temperature (F)	BTUH at 1000CFM	Hours in Use	Percentage of Yearly Cooling
104	78	28600	1026	100.00%
100.4	78	24640	978	99.33%
96.8	78	20680	842	97.44%
93.2	78	16720	619	94.33%
89.6	78	12760	343	90.49%

The target temperature was 78F because that is the temperature where the tower would function at 1000CFM, and the cooling requirement for the coil would actually be greater if it cooled to 86F but at 2000CFM. For the hours in use, it is assumed that if the coil is operational at any temperature, it is operational for all temperatures below it in this table. We decided not to pursue a supplementary system design any further than this due to the high cooling requirements of the system and the already high effectiveness of the tower. For a solar house in a climate like that in Errachidia, some sacrifices will always need to be made to keep costs reasonable.

ADDITIONAL CONSIDERATIONS

Construction

Construction is another main aspect of the building. A goal of this project was to make the structure as modular and easily constructible as possible so that it may be built within the one-week competition standard. In this section, the overall construction process of the main building and PDEC tower are described. This does not include the construction of the window, finishes, or furnishings. Only the structure was determined.

The first step in construction is placing the adjustable footings. The footings provide a grid so that the floor beams can be placed. Footings are placed in every place that multiple beams meet. Because of this, there are 21 footings that support the structure.

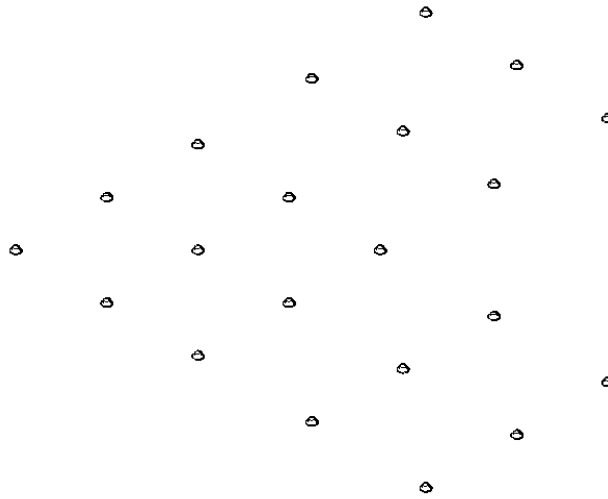

Figure 30: Placement of Adjustable Footings

Next, the floor beams are placed on top of the footings. These 6 x 10 beams act as the main foundation for the structure. After the beams are placed atop the footings, they are leveled. This ensures that the building will have a level foundation though the site may not be level. These beams are placed directly on top of the footings and are screwed into the footings using simple wood screws.

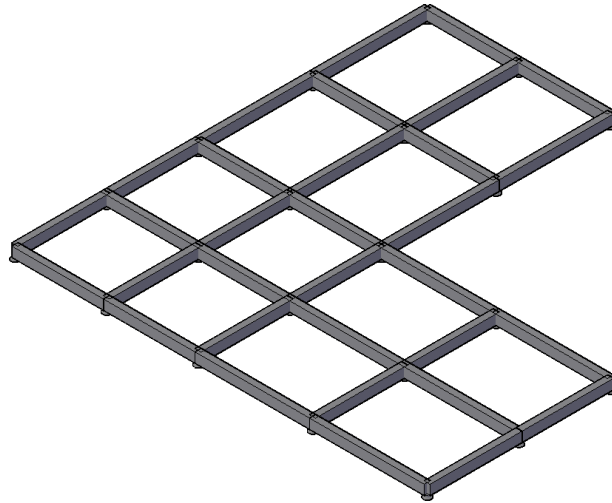

Figure 31: Floor Beam Framing

Next, the floor panels are placed on top of the floor beams. These panels fit directly on top of the grid that the beams create. They are 16-foot spans that are supported at the midpoint and the two ends. The panels are attached to the floor beams by using simple wood screws.

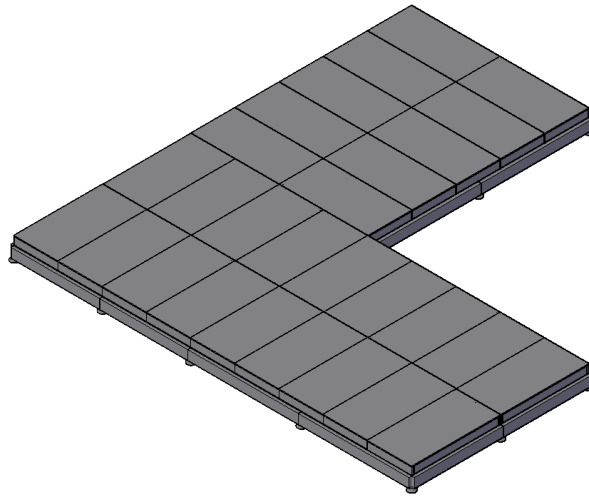

Figure 32: Floor Panel Construction

After the floor is finished, the walls are placed on the structure. The sandwich panels for the wall are placed directly on top of the floor panels and connect through a bottom sill that are pre-attached to the floor panels as stated in Section 2. Using the sandwich panels saves time here so that walls do not need to be constructed using a framing construction technique.

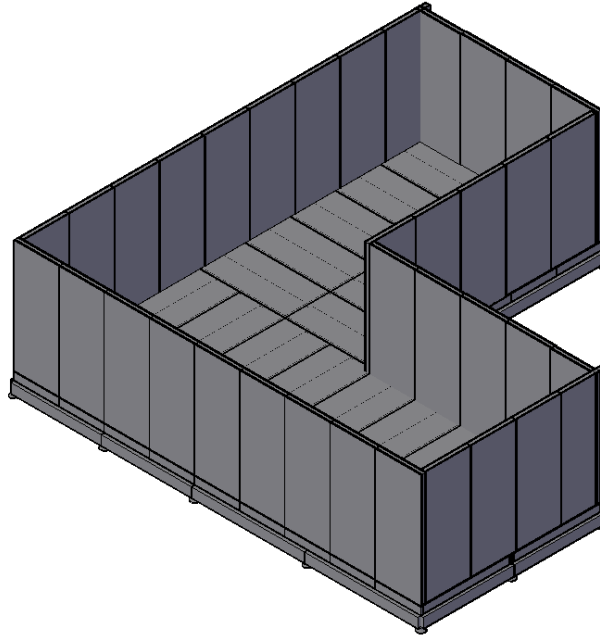

Figure 33: Addition of Walls

Finally, the roof panels are placed on top of the walls. These panels fit directly on top of the walls just as the floor panels fit with the walls. They connect through a top sill that is pre-attached to the panels.

Cost Estimate

One of the main considerations for the structure was cost. Because the solar decathlon requires that houses are marketed for the middle-class, it is important that innovation must not drive up the cost of living. Therefore, after the structural design was completed, a cost estimate of the structural system was performed. The structural components were all divided into categories. After, the quantity of each category was determined. The national cost per unit for each category were then taken from the RSMeans Building Construction Cost Data. The structural wood cost estimate can be seen in Appendix E. This total can be divided throughout the square footage of the building so that it can be compared to typical construction costs. The total calculated corresponds to about \$12.30 per square foot.

The values for this cost estimate includes the cost of the wood and EPS materials only. It does not include any costs for overhead, profit, or labor costs due to the fact that the structure will be constructed on the Solar Decathlon site by students and others working on the project. Labor hours were calculated. Without prefabrication, the amount of labor hours that it takes to execute this building is 122 hours. This number was found using basic information provided by RSMeans. However, this does not account for prefabrication of the floor and roof beams. It also does not account for a large crew team helping to construct the materials in the quickest amount of time possible. Therefore, construction time would be reduced greatly if the building were to be constructed for the competition.

Future Work

Because the competition does not take place until September of 2019, this project was a preliminary design. Work with future MQP teams and advisors will need to be done in order to develop a

full design for the Solar Decathlon. In this chapter, we will discuss future work that must be done to continue on the design process.

Architectural Design

For the architectural design, future students should enter a design development phase. Because this project underwent a preliminary design, there are still changes that need to be done in order to produce the most efficient building.

Structural Design

As for the structure, there are more ways to optimize the design and reduce the amount of materials that are used. Sandwich panels could be used for the structural panels present in the floor and the roof. This would reduce the amount of lumber that the structure uses. Also, more modeling of the structure could be done so that every piece is modeled appropriately.

Mechanical Design

As stated in section 4, a supplementary system will be necessary to keep the building interior within competition requirements year-round. Future teams will need to use the data we have to fully design and implement such a system.

Electrical, Plumbing, Fire Protection, Appliances

The electrical, plumbing, and fire protection design of the house did not occur during this portion of the project. The main focus for this design phase included just the preliminary architectural, structural, and mechanical designs. This therefore leaves work for future teams.

For the electrical consideration of the design, the competition outlines the requirements for appliances, electronics, lighting, and electrical energy. Some important requirements are listed below in Table 18. Future MQPs should consider these factors when designing the electrical components of the design.

Table 17: Electrical Requirements for the Solar Decathlon Africa

Type	Requirement
Refrigerator	$1.0^{\circ}\text{C} \leq \text{Temperature} \leq 4.5^{\circ}\text{C}$
Freezer	$-30^{\circ}\text{C} \leq \text{Temperature} \leq -15^{\circ}\text{C}$
Clothes Washer	One complete wash cycle
Clothes Drying	% of the original weight < 100
Oven	Oven Temperature $\geq 220^{\circ}\text{C}$
Light Intensity	Lighting Level ≥ 300 lux
Energy Performance	Net Electrical Energy ≥ 0 kwh

CONCLUSION

The overall goal of this project was to design a house that can be submitted as a proposal into the Solar Decathlon Africa competition that will take place in 2019. Throughout the course of this project, the team learned a lot about the overall design, construction, and development processes that go into creating a building. An architectural, structural, and mechanical design was completed. This allowed student of different backgrounds and concentrations to work together to complete this project. We hope that future Major Qualifying Projects will continue to work that was completed so that this house may participate in the Solar Decathlon in 2019.

REFERENCES

2005 American Wood Council National Design Specification, (2005). American Wood Council

2012 International Residential Code (IRC), (2012). International Code Council

2015 International Building Code (IBC), (2015). International Code Council

American Society of Heating, R. a. A. E. (2013). *2013 Ashrae handbook: Fundamentals* (Inch-pound ed.). Atlanta, Ga.: Ashrae.

American Society of Heating, R. a. A. E. (2013). *2016 Ashrae handbook: HVAC systems and equipment* (Inch-pound ed.). Atlanta, Ga.: Ashrae.

Givoni, B. (1997). Performance of the “shower” cooling tower in different climates. *Renewable Energy*, 10(2-3), 173-178. doi:10.1016/0960-1481(96)00059-6

Minimum Design Loads for Buildings and Other Structures (ASCE 7-10), (2013). American Society of Civil Engineers

Solar Decathlon Africa Rules Draft – Version 2.0 – 30/01/2018 (2018). Solar Decathlon Africa

APPENDICES

Appendix A: Structural Load Calculations

The following Appendix contains calculations for the loads that act on the structure of the building.

Dead Loads

Dead loads acting on floor beams:

Material	Dead Load (psf)
6x10 Beams	9.0
2x8 Framing	2.2
2x10 Framing	2.9
3/4" Plywood	2.2
Wall Panels	3.2
Roof System	2.0
Total Dead Load	21.5

Dead loads acting on floor panels:

Material	Dead Load (psf)
2x8 Framing	2.2
2x10 Framing	2.9
3/4" Plywood	2.2
Wall Panels	3.2
Roof System	2.0
Total Dead Load	12.5

Dead loads acting on roof panels:

Material	Dead Load (psf)
2x10 Framing	2.9
3/4" Plywood	2.2
Roof System	2.0
Total Dead Load	7.1

Because the dead load is higher than the original 15 psf for the 6x10 floor beams, the structural calculation was completed again using the true dead load. This did not change the beam sizing.

Wind Loads

Summary Table

		Source	Comments
Mean Roof Height	10 ft		The height of the flat roof.
Enclosure Classification	Partially	ASCE 7-10 Section 26.2	Satisfies the “Partially Enclosed” criteria.
Basic Wind Speed (V)	115 mph	Solar Decathlon Code	The basic wind speed for the competition was given by the Solar Decathlon rulebook.
Wind Directionality Factor (K_d)	0.85	ASCE 7-10 Table 26.6-1	This value is 0.85 for all buildings.
Topographic Factor (K_{zt})	1	ASCE 7-10 Section 26.8	Because the site is assumed to be flat, the topography does not satisfy all five requirements for a non-one factor.
Building Height Coefficient (K_z)	0.85	ASCE 7-10 Table 27.3-1	
Gust Factor (G)	0.85	ASCE 7-10 Section 26.9.4	Because the building is classified as a rigid structure, the Gust Factor is 1.
Wind Pressure (q_z)	24.46 psf	ASCE 7-10 Equation 27.3-1	This calculation was performed using the q_z equation above.
Windward p	3.18 psf	ASCE 7-10 Equation 27.4-1	Assuming C_p is 0.8 (ASCE 7-10 Table 27.4-1)
Side Wall p	-28.01 psf	ASCE 7-10 Equation 27.4-1	Assuming C_p is -0.7 (ASCE 7-10 Table 27.4-1)
Leeward p	-19.69 psf	ASCE 7-10 Equation 27.4-1	Assuming C_p is -0.3 (ASCE 7-10 Table 27.4-1)
Roof p	-9.71 psf	ASCE 7-10 Equation 27.4-1	Assuming C_p is 0.18 (ASCE 7-10 Table 27.4-1)
Final p	27.6 psf	ASCE 7-10 Table 27.6-1	This value was based off an exposure category C, a basic wind speed of 115, and a height < 15 ft.

Seismic Loads

Summary Table

		Source	Comments
1. Determine Building Occupancy Category			
Building Occupancy Category	II	IBS 2015 Table 1604.5	This occupancy represents the normal occupancy for buildings that do not meet characteristics for category I, III, or IV.
1. Determine S_s and S_1			
Spectral Response Acceleration Parameter at 0.2 seconds (S_s)	0.339g	USGS Report	Because there are no values for Morocco, seismic zones were compared to U.S. locations and S_s values were chosen accordingly
Spectral Response Acceleration Parameter at 1 second (S_1)	0.113g	USGS Report	Because there are no values for Morocco, seismic zones were compared to U.S. locations and S_1 values were chosen accordingly
2. Determine Site Characteristics			
Site Classification	D	ASCE 7-10 & Solar Decathlon Code	The site classification accounts for the variety in soil types. Site Class D is used when information about the soil is not provided.
Site Coefficient (F_a)	1.529	ASCE 7-10 Table 11.4-1	These values were interpolated by using the values 0.25 and 0.5 for S_s .
Site Coefficient (F_v)	2.348	ASCE 7-10 Table 11.4-2	These values were interpolated by using the values 0.25 and 0.5 for S_1 .
3. Design Ground Motion Parameters			
Design Spectral Response Acceleration at 0.2 Seconds $S_{DS} = 2/3(F_a)(S_s)$	0.346	ASCE 7-10 Equation 11.4-3	Provides the design value based on S_d .
Design Spectral Response Acceleration at 1 Second $S_{D1} = 2/3(F_a)(S_1)$	0.177	ASCE 7-10 Equation 11.4-4	Provides the design value based on S_1 .
5. Identify Seismic Design Category and Method			
Risk Category	II	IBC 2015 Table 1604.5	
Seismic Design Category	B	ASCE 7-10 Table 11.6-1 and 11.6-2	
6. Calculate Seismic Response Coefficient			
Earthquake Importance Factor (I_e)	1.00	ASCE 7-10 Table 1.5-2	Risk Category II buildings are assigned an earthquake importance factor of 1. This is a safety design factor.

7. Select Structural System and Parameters				
Response Modification Coefficient (R)	7	ASCE 7-10 Table 12.2-1B	These values are used for light-frame (wood) walls sheathed with wood structural panels rated for shear resistance.	
System Over Strength Parameter (Ω)	2.5	ASCE 7-10 Table 12.2-1B		
Deflection Amplification Factor	4.5	ASCE 7-10 Table 12.2-1B		
8. Determine Seismic Weight				
Effective Seismic Weight (W) [lbs]	17973.15	ASCE 7-10 Section 12.7.2	The effective seismic weight includes the dead weight of the structure.	
Seismic Response Coefficient (C_s) $C_s = S_{DS}/(R/I_e)$	0.049358	ASCE 7-10 Equation 12.8-2	This value converts the seismic weight to lateral force acting on the building.	
9. Calculate Total Design Shear at Base				
Seismic Base Shear $V = C_s * W$ [lbs]	887.13	ASCE 7-10 Equation 12.8-1	This value is the lateral load that acts on the base of the structure during an earthquake.	
10. Calculate Vertical Distribution Factor				
$W_{\text{floor}} * h_{\text{floor}}$	10488	ASCE 7-10 Equation 12.8-12	Assuming h = 1 ft	
$W_{\text{roof}} * h_{\text{roof}}$	53346		Assuming h = 10 ft	
C_{vx}				
C_{vF}	0.1643			
C_{vR}	0.8357			
10. Calculate Lateral Seismic Force				
F_x		ASCE 7-10 Equation 12.8-12		
F_F	145.75			
F_R	741.37			
11. Basic Combinations for Allowable Stress Design				
$(1.0+0.14S_{DS})D+0.7\rho Q_E$		ASCE 7-10 Section 2.4.3 #5		
Horizontal Factored Load	645.75	lbs		
Vertical Factored Load	15.73	psf		
$(1.0+0.10S_{DS})D+0.525\rho Q_E+0.75L+0.75L_r$		ASCE 7-10 Section 2.4.3 #6		
Horizontal Factored Load	484.32	lbs		
Vertical Factored Load	75.52	psf		
$(0.6-0.14S_{DS})D+0.7\rho Q_E$		ASCE 7-10 Section 2.4.3 #8		
Horizontal Factored Load	645.75	lbs		
Vertical Factored Load	8.27	psf		

Appendix B: Structural Design Calculations

Symbols

ω	Total Load
L	Length of Member
M	Moment
V	Shear
F'_b	Allowable Bending
F'_v	Allowable Shear
Δ	Deflection
S_{req}	Required Section Modulus
A_{req}	Required Cross Sectional Area
I_{req}	Required Moment of Inertia
ω_b	Uniform Load Based on Bending
ω_s	Uniform Load Based on Shear
ω_{tl}	Total Load Based on Stiffness

Equations

$$M = \frac{\omega L^2}{8}$$

$$V = \frac{\omega L}{2}$$

$$F'_b = F_b \times C_D C_M C_t C_L C_F C_v C_{fu} C_i C_r C_c C_f$$

$$F'_v = F_v \times C_D C_M C_t C_i$$

$$\Delta_{Total} = \frac{L}{240}$$

$$\Delta_{LL} = \frac{L}{360}$$

$$S_{req} = \frac{M}{F'_b}$$

$$A_{req} = \frac{3V}{2F'_v}$$

$$I_{req} = \frac{5\omega L^2}{384E\Delta}$$

Beam Design

Summary Table

Tributary Area						Comments
Length (L)	10	ft				
Tributary Width	8	ft				
Tributary Area	80	ft ²				
Design Loads						
Total Load (ω)	65	psf				D + L
Calculate Moment and Shear						
Moment (M)	6500	lb-ft				$M = \omega L^2/8$
Shear (V)	2600	lb				$V = \omega L/2$
Calculate Design Loads						
Bending (F'_b)	1275	psi				
Shear (F'_v)	180	psi				
Calculate Deflection						
Total Load	0.5	in				2015 IBC Table 1604.3
Live Load	0.3333	in				2015 IBC Table 1604.3
Calculate Requirements						
Section Modulus (S)	61.176	in ³				$S_{req} = M/F'_b$
Cross-Sectional Area (A)	21.667	in ²				$A_{req} = 3V/2F'_v$
Moment of Inertia (I)	123.158	in ⁴				$I_{req} = 5\omega L^4/384E\Delta$
Member Selection						
Member	6 x 10					2005 AWC NDS Table 1A
Section Modulus	82.73	in ³	<	S	OK	2005 AWC NDS Table 1A
Cross-Sectional Area	52.25	in ²	<	A	OK	2005 AWC NDS Table 1A
Moment of Inertia	393.0	in ⁴	<	I	OK	2005 AWC NDS Table 1A

Floor Panel Design

Summary Table

Joist Calculations						
Tributary Area						Comments
Length (L)	8	ft				
Tributary Width	2	ft	=			
Tributary Area	16	ft ²				
Design Loads						
Total Load (ω)	65	psf				D + L
Calculate Moment and Shear						
Moment (M)	1040	lb-ft				$M = \omega L^2/8$
Shear (V)	520	lb				$V = \omega L/2$
Calculate Design Loads						
Bending (F'_b)	1366.2	psi				
Shear (F'_v)	198	psi				
Calculate Deflection						
Total Load	0.4	in				2015 IBC Table 1604.3
Live Load	0.2667	in				2015 IBC Table 1604.3
Calculate Requirements						
Section Modulus (S)	9.135	in ³				$S_{req} = M/F'_b$
Cross-Sectional Area (A)	3.939	in ²				$A_{req} = 3V/2F'_v$
Moment of Inertia (I)	15.764	in ⁴				$I_{req} = 5\omega L^4/384E\Delta$
Member Selection						
Member	2 x 8					2005 AWC NDS Table 1A
Section Modulus	13.14	in ³	<	S	OK	2005 AWC NDS Table 1A
Cross-Sectional Area	10.88	in ²	<	A	OK	2005 AWC NDS Table 1A
Moment of Inertia	47.63	in ⁴	<	I	OK	2005 AWC NDS Table 1A

Plywood Calculations			
Dimensions			Comments
Thickness	8	ft	
Length	2	ft	
Width	16	ft ²	
Given			
Bending Strength	1014		
Axial Strength (Tension)	405		
Axial Strength (Compression)	7500		
Planar Shear	325		
Bending Stiffness	440000		
1. Calculate Uniform Loading Based on Bending			
Uniform Load (ω_b)	169	psf	
2. Calculate Uniform Load Based on Shear			
Uniform Load (ω_s)	260	psf	
3. Calculate Allowable Loads Based on Stiffness			
Total Allowable Load (ω_{tl})	285	psf	

Roof Panel Design

Summary Table

Joist Calculations						
Tributary Area						Comments
Length (L)	16	ft				
Tributary Width (TW)	1.3333	ft				
Tributary Area	21.33	ft ²				
Design Loads						
Total Load (ω)	45	psf	=	520		D + L
Calculate Moment and Shear						
Moment (M)	1920	lb-ft				
Shear (V)	480	lb				
Calculate Design Loads						
Bending (F'_b)	1366.2	psi				
Shear (F'_v)	198	psi				
Calculate Deflection						
Total Load	0.8	in				2015 IBC Table 1604.3
Live Load	0.5333	in				2015 IBC Table 1604.3
Calculate Requirements						
Section Modulus (S)	16.86	in ³				
Cross-Sectional Area (A)	3.64	in ²				
Moment of Inertia (I)	69.12	in ⁴				
Member Selection						
Member	2 x 10					2005 AWC NDS Table 1A
Section Modulus	21.39	in ³		S	OK	2005 AWC NDS Table 1A
Cross-Sectional Area	13.88	in ²		A	OK	2005 AWC NDS Table 1A
Moment of Inertia	98.93	in ⁴	<	I	OK	2005 AWC NDS Table 1A

Summary Table

Plywood Calculations			
Dimensions			Comments
Thickness	8	ft	
Length	2	ft	
Width	16	ft ²	
Given			
Bending Strength	1014		
Axial Strength (Tension)	405		
Axial Strength (Compression)	7500		
Planar Shear	325		
Bending Stiffness	440000		
1. Calculate Uniform Loading Based on Bending			
Uniform Load (ω_b)	169	psf	
2. Calculate Uniform Load Based on Shear			
Uniform Load (ω_s)	260	psf	
3. Calculate Allowable Loads Based on Stiffness			
Total Allowable Load (ω_{tl})	285	psf	

Wall Sandwich Panel Design

Summary Table

1. Calculate A_v, S, I				
Shear Area (A_v)	51	in ²		
Moment of Inertia (I)	43.32	in ⁴		
Section Modulus (S)	17.33	in ³		
2. Calculate Applied and Allowable Moment				
Applied Moment	562.5	in-lbf	Ratio	
Allowable Moment [Tension] (M_t)	1766.9	in-lbf	0.318	OK
Allowable Moment [Compression] (M_c)	2548.4	in-lbf	0.221	OK
3. Calculate Applied and Allowable Shear				
Applied Shear	225	lbf		
Size Adjustment Factor (C_{fv})	1		Ratio	
Allowable Shear Strength (V)	1152.6	lbf	0.195	OK
4. Calculate Actual and Allowable Deflection				
Deflection	0.6237	in	Ratio	
Limit	0.6667	in	0.935	OK

Appendix C: Written Load and Structural Calculations

Wind Loads

Solar Decathlon Standards:

$V = 115$ mph
Exposure class C

Building (Assuming Windward = North)

- height $<$ base $\frac{1}{2}$ length rigid structure
- Partially enclosed

$V = 115$ mph

$K_d = 0.85$

$k_{zt} = 1$

$K_z = 0.85$

$G = 0.85$

$$q_z = 0.00256 (K_z)(k_{zt})(K_d)(V^2)$$

$$q_z = 0.00256 (0.85)(1)(0.85)(115^2)$$

$$q_z = 27.46 \text{ psf}$$

$GCP_i \rightarrow$ partially enclosed space = 0.55

Windward

$C_p = 0.8$

$$P = q_z \times (G)(C_p) - (q_z)(GCP_i)$$

$$P = 27.46 \text{ psf} (0.85)(0.8) - (27.46)(0.55)$$

$$P = 3.18 \text{ psf}$$

Side Wall

$C_p = -0.7$

$$P = 27.46 \text{ psf} (0.85)(-0.7) - (27.46)(0.55)$$

$$P = -28.01$$

Leeward

$B = 36$ ft

$L = 16$ ft

$$\frac{B}{L} = 2.25$$

$C_p = -0.3$

$$P = 27.46 \text{ psf} (0.85)(-0.3) - (27.46)(0.55)$$

$$P = -19.69 \text{ psf}$$

Roof

$C_p = 0.18$

$$P = 27.46 \text{ psf} (0.85)(0.18) - (27.46)(0.55)$$

$$P = -9.71 \text{ psf}$$

SHORTCUT

ASCE 7-10 Table 27.6-1

$$P = 27.6 \text{ psf}$$

Wind Loads cont.

Tower

$$v = 115 \text{ mph}$$

$$K_d = 0.85$$

$$K_{zt} = 1$$

$$K_z = 0.85$$

$$G = 0.85$$

$$q_z = 0.00256 (K_z)(K_{zt})(K_d)(V^2)$$

$$q_z = 0.00256 (0.85)(1)(0.85)(115^2)$$

$$q_z = 24.46 \text{ psf}$$

$$GCP, \rightarrow \text{enclosed space} = 0.18$$

Windward

$$C_p = 0.8$$

$$P = 24.46 (0.85)(0.8) - (24.46)(0.18)$$

$$P = 12.23 \text{ psf}$$

Side Wall

$$C_p = -0.7$$

$$P = 24.46 (0.85)(-0.7) - (24.46)(0.18)$$

$$P = -19 \text{ psf}$$

Leeward

$$B = 6 \text{ ft}$$

$$L = 6 \text{ ft}$$

$$\frac{B}{L} = \frac{6}{6} = 1$$

$$C_p = -0.5$$

$$P = 24.46 (0.85)(-0.5) - (24.46)(0.18)$$

$$P = -14.80 \text{ psf}$$

SHORTCUT

ASCE 7-10 Table 27.6-1

$$P = 27.6 \text{ psf}$$

Seismic Loads

Occupancy Category: II

$$S_s = 0.339g \quad S_1 = 0.113g \quad [\text{USGS Report}]$$

Site classification: D

$$F_a = 1.529$$

$$F_v = 2.348$$

$$S_{Ds} = \frac{2}{3} (F_a)(S_s) = \frac{2}{3} (1.529)(0.339)$$

$$S_{Ds} = 0.346$$

$$S_{D1} = \frac{2}{3} (F_v)(S_1) = \frac{2}{3} (2.348)(0.113)$$

$$S_{D1} = 0.117$$

Risk Category = II

SDC = B

$$I_e = 1.00$$

$$R = 7$$

$$\Omega = 2.5$$

Deflection Amp. = 4.5
Factor

Effective Seismic Weight

$$W = 17973.15 \text{ lbs}$$

$$C_s = \frac{S_{Ds}}{R/I_e} = \frac{0.346}{7/1} = 0.049358$$

Seismic Base Shear:

$$V = C_s(W) = 0.049358(17973.15 \text{ lbs}) = 887.13 \text{ lbs}$$

Vertical Dist. Factor:

$$W_{\text{floor}} \times h_{\text{floor}} = 10488 \text{ lb (1 ft)} = 10488$$

$$W_{\text{roof}} \times h_{\text{roof}} = 4849.16 \text{ lb (1 ft)} = 53346$$

$$C_{vF} = \frac{10488}{10488 + 53346} = 0.1643$$

$$C_{vR} = \frac{53346}{10488 + 53346} = 0.8357$$

Lateral Seismic Force:

$$F_F = C_{vF}(V) = 0.1643(887.13 \text{ lb})$$

$$F_F = 145.75 \text{ lbs}$$

$$F_R = C_{vR}(V) = 0.8357(887.13 \text{ lb})$$

$$F_R = 741.37 \text{ lbs}$$

Basic Combinations:

1. $(1.0 + 0.14 S_{Ds})D + 0.7 P Q E$

$$\text{Horizontal} = 0.7(1.0)(887.13 \text{ lbs})$$

$$= 615.75 \text{ lb}$$

$$\text{Vertical} = (1 + 0.14(0.346))15$$

$$= 15.73 \text{ psf}$$

2. $(1.0 + 0.10 S_{Ds})D + 0.525 P Q E$
 $+ 0.75 L + 0.75 L_r$

$$\text{Horizontal} = 0.525(1)(887.13 \text{ lbs})$$

$$= 467.32 \text{ lb}$$

$$\text{Vertical} = (1 + 0.1(0.346))15 +$$

$$(0.75 \times 50) + (0.75 \times 30) = 75.5 \text{ psf}$$

3. $(0.6 - 0.14 S_{Ds})D + 0.7 P Q E$

$$\text{Horizontal} = 0.7(1)(887.13 \text{ lbs})$$

$$= 615.75 \text{ lb}$$

$$\text{Vertical} = (0.6 - 0.14(0.346))(15)$$

$$= 8.27 \text{ psf}$$

Beam Design

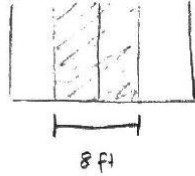
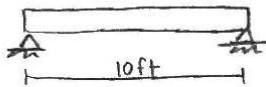

Length = 10 ft = 120 in
 Trib Width = 8 ft
 Trib Area = 80 ft² [10 x 8]

Loads

LL = 50 psf
 DL = 15 psf
 TL = 65 psf

L + D = TL
 50 + 15 = 65 psf

$65 \frac{\text{lb}}{\text{ft}^2} \times 8 \text{ ft} = 520 \text{ plf} \times \frac{12 \text{ in}}{\text{ft}} = 433 \text{ pli}$

Moment

$M = \frac{wL^2}{8} = \frac{520 \text{ plf} (10 \text{ ft})^2}{8} = 6500 \text{ lb-ft}$

Shear

$V = \frac{wL}{2} = \frac{520 \text{ plf} (10 \text{ ft})}{2} = 2600 \text{ lb}$

Design Loads

$F'_b = F_b \times C_D C_M C_L C_E C_G C_{Fu} C_L C_r C_c C_f$
 $F'_b = 1350 \times 0.8 (1.15) = 1242 \text{ psi}$

$F'_v = F_v \times C_D C_m C_a C_u$
 $F'_v = 170 \times 1 = 170 \text{ psi}$

Deflection

Total Load: $\Delta_{TL} = \frac{L}{240}$

$\frac{10 \text{ ft}}{240} \rightarrow \frac{10 \text{ ft} \times \frac{12 \text{ in}}{\text{ft}}}{240}$

$\Delta_{TL} = 0.5 \text{ in}$

Live Load: $\Delta_{LL} = \frac{L}{360}$

$\frac{10 \text{ ft}}{360} \rightarrow \frac{10 \text{ ft} \times \frac{12 \text{ in}}{\text{ft}}}{360}$

$\Delta_{LL} = 0.333 \text{ in}$

Requirements

$S_{req} = \frac{M}{F'_b} = \frac{6500 \text{ lb-ft}}{1242 \text{ psi}}$

$S_{req} = 62.80 \text{ in}^3$

$A_{req} = \frac{3V}{2F'_v} = \frac{3(2600 \text{ lb})}{2(170 \text{ psi})}$

$A_{req} = 22.94 \text{ in}^2$

$I_{req} = \frac{5wL^4}{384 E \Delta} = \frac{5(433 \text{ pli})(120 \text{ in})^4}{384 (1600000)(0.5)}$

$I_{req} = 146.25 \text{ in}^4$

Member Selection

6x10

$S = 82.73 \text{ in}^3 > 62.80 \text{ in}^3$
 $A = 52.23 \text{ in}^2 > 22.94 \text{ in}^2$
 $I = 393.0 \text{ in}^4 > 146.25 \text{ in}^4$

final size

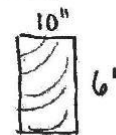

Floor Panel Design

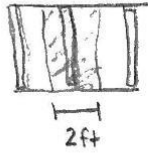

$$\begin{aligned} \text{Length} &= 8 \text{ ft} = 96 \text{ in} \\ \text{Trib Width} &= 2 \text{ ft} \\ \text{Trib Area} &= 16 \text{ ft}^2 \quad [8 \times 2] \end{aligned}$$

Loads:

$$\begin{aligned} LL &: 50 \text{ psf} & L+D &= TL \\ DL &: 15 \text{ psf} & 50+15 &= 65 \text{ psf} \\ TL &: 65 \text{ psf} \end{aligned}$$

$$65 \frac{\text{lb}}{\text{ft}^2} \times 2 \text{ ft} = 130 \text{ plf} \times \frac{12 \text{ in}}{\text{ft}} = 10.83 \text{ pli}$$

Moment:

$$m = \frac{wL^2}{8} = \frac{130 \text{ plf} (8 \text{ ft})^2}{8} = 1040 \text{ lb-ft}$$

Shear:

$$V = \frac{wL}{2} = \frac{130 \text{ plf} (8 \text{ ft})}{2} = 520 \text{ lb}$$

Design Loads

$$F'_b = F_b \times C_D C_M C_E C_G C_F C_V C_{Fu} C_u C_r C_e C_f$$

$$F'_b = 900 \times 1.1 \times 1.15 \times 1.2 = 1366.2 \text{ psi}$$

$$F'_v = F_v \times C_D C_M C_E C_u$$

$$F'_v = 180 \times 1.1 = 198 \text{ psi}$$

Deflection:

$$\Delta_{TL} = \frac{L}{240}$$

$$\Delta_{LL} = \frac{L}{360}$$

$$\Delta_{TL} = \frac{8 \text{ ft} \times 12 \text{ in/ft}}{240} = 0.4 \text{ in}$$

$$\Delta_{LL} = \frac{8 \text{ ft} \times 12 \text{ in/ft}}{360} = 0.267 \text{ in}$$

Requirements:

$$S_{req} = \frac{m}{F'_b} = \frac{1040 \text{ lb-ft}}{1366.2 \text{ psi}}$$

$$S_{req} = 9.134 \text{ in}^3$$

$$A_{req} = \frac{3V}{2F'_v} = \frac{3(520 \text{ lb})}{198 \text{ psi}}$$

$$A_{req} = 3.939 \text{ in}^2$$

$$I_{req} = \frac{5WL^4}{384EA} = \frac{5(10.83 \text{ pli})(96 \text{ in})^4}{384(1600000)(0.4 \text{ in})}$$

$$I_{req} = 18.72 \text{ in}^4$$

Member Selection

2x8

$$S = 13.14 \text{ in}^3 > 9.134 \text{ in}^3$$

$$A = 10.33 \text{ in}^2 > 3.94 \text{ in}^2$$

$$I = 47.63 \text{ in}^4 > 18.72 \text{ in}^4$$

final size:

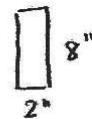

Wall Panel Calculation

Given $F_t = 101.96 \text{ psi}$

$F_c = 147.06 \text{ psi}$

$E_b = 10156.33 \text{ psi}$

$G = 9300 \text{ psi}$

$F_v = 22.6 \text{ psi}$

$A_f = 16.5 \text{ psi}$

Loads

$D = 15 \text{ psf}$

$D+L_r = 45 \text{ psf}$

$0.6D+W = 42.6 \text{ psf}$

$0.6D+0.7E = 38.1 \text{ psf}$

$TL = D + L_r = 15 + 30 = 45 \text{ psf}$

Panel Size:

Core Thickness = 3.5" Actual = 5"

Width = 4 ft

height = 10 ft

$$A_v = \frac{12 (\text{Core thickness} + \text{Actual})}{2} = \frac{(3.5" + 5") (12)}{2} = 51 \text{ in}^2$$

$$I = \frac{A_f (\text{Core thick} + 4.625)^2}{16} = \frac{16.5 \text{ psi} (3.5 \text{ in} + 4.625)^2}{16} = 43.33 \text{ in}^4$$

$$S = \frac{2(I)}{5} = \frac{2(43.33)}{5} = 17.33 \text{ in}^3$$

Moment

$$M_{\text{Applied}} = \frac{1}{8} (TL) (\text{Core Thick})^2 = \frac{1}{8} (15 \text{ pli}) (3.5 \text{ in}^2) = 187.5 \text{ in-lbf}$$

$$M_t = F_t (S) = 101.96 \text{ psi} (17.33 \text{ in}^3) = 1766.9 \text{ in-lbf} > 187.5 \checkmark$$

$$M_c = F_c (S) = 147.06 \text{ psi} (17.33 \text{ in}^3) = 2548.4 \text{ in-lbf} > 187.5 \checkmark$$

Shear

$$V_{\text{Applied}} = \frac{1}{2} (TL) (\text{Core thick}) = \frac{1}{2} (15 \text{ pli}) (3.5 \text{ in}) = 75 \text{ lbf}$$

$$V_{\text{allow}} = F_v (A_v) = 22.6 \text{ psi} (51 \text{ in}^2) = 1152.6 \text{ lbf} > 75 \text{ lbf} \checkmark$$

Deflection

$$\Delta = \frac{5 w L^4}{384 EI} = \frac{5 (15 \text{ pli}) (4 \text{ ft})^4 (1728 \text{ in}^4/\text{ft}^4)}{384 (10156.33 \text{ psi}) (43.33 \text{ in}^4)} = 0.196 \text{ in}$$

$$\Delta_{\text{Limit}} = \frac{h}{180} = \frac{16 \text{ ft} (12 \text{ in}/\text{ft})}{180} = 0.667 \text{ in} > 0.196 \text{ in} \checkmark$$

Appendix D: Total Building Weight

Flooring	Unit Weight		Amount		Total	
Floor Beams	12.7	lb/ft	280	ft	3556	lbs
Floor Panels	259.5	lbs	14		3633	lbs
Floor Finishes	N/A	lb/ft	N/A	ft	N/A	lbs
Walls						
Wall panels	184	lbs	36		6624	lbs
Wall Finishes	N/A	lb/ft	N/A	ft	N/A	lbs
Roof						
Roof Beams	7.869	lb/ft	16	ft	126	lbs
Roof Panels	390	lbs	14		5460	lbs
Roof Finishes	N/A	lb/ft	N/A	ft	N/A	lbs
Total Weight					19,400	lbs

Appendix E: RISA Modeling Results

Floor Beams

Member	Shape	Cod...	Lo...	LC	Shea...	Lo...	D.	LC	Fc' [p...	Ft' [psi]	Fb1' [...]	Fb2' [...]	Fv [p...	RB	CL	CP	Eqn	
1	M1	6X10	.661	8	1	.282	8	z	1	1054.45	1080	2149.06	1598.4	272	5.491	.995	.712	3.9-3
2	M2	6X10	.666	0	1	.283	0	z	1	1054.45	1080	2149.06	1598.4	272	5.491	.995	.712	3.9-3
3	M3	6X10	.909	10	1	.401	10	z	1	811.932	1080	2146.01	1598.4	272	6.139	.994	.549	3.9-3
4	M4	6X10	.907	0	1	.666	0	z	1	811.932	1080	2146.01	1598.4	272	6.139	.994	.549	3.9-3
5	M5	6X10	.907	10	1	.666	10	z	1	811.932	1080	2146.01	1598.4	272	6.139	.994	.549	3.9-3
6	M6	6X10	.909	0	1	.401	0	z	1	811.932	1080	2146.01	1598.4	272	6.139	.994	.549	3.9-3
7	M7	6X10	.666	8	1	.283	8	z	1	1054.45	1080	2149.06	1598.4	272	5.491	.995	.712	3.9-3
8	M8	6X10	.661	0	1	.282	0	z	1	1054.45	1080	2149.06	1598.4	272	5.491	.995	.712	3.9-3
9	M9	6X10	.917	10	1	.355	10	z	1	811.932	1080	2146.01	1598.4	272	6.139	.994	.549	3.9-3
10	M10	6X10	.917	0	1	.343	0	z	1	811.932	1080	2146.01	1598.4	272	6.139	.994	.549	3.9-3
11	M11	6X10	.541	8	1	.241	8	z	1	1054.45	1080	2149.06	1598.4	272	5.491	.995	.712	3.9-3
12	M12	6X10	.542	0	1	.274	0	z	1	1054.45	1080	2149.06	1598.4	272	5.491	.995	.712	3.9-3
13	M13	6X10	.542	8	1	.274	8	z	1	1054.45	1080	2149.06	1598.4	272	5.491	.995	.712	3.9-3
14	M14	6X10	.541	0	1	.241	0	z	1	1054.45	1080	2149.06	1598.4	272	5.491	.995	.712	3.9-3
15	M15	6X10	.917	10	1	.343	10	z	1	811.932	1080	2146.01	1598.4	272	6.139	.994	.549	3.9-3
16	M16	6X10	.917	0	1	.355	0	z	1	811.932	1080	2146.01	1598.4	272	6.139	.994	.549	3.9-3
17	M17	6X10	.915	10	1	.365	10	z	1	811.932	1080	2146.01	1598.4	272	6.139	.994	.549	3.9-3
18	M18	6X10	.642	0	1	.282	0	z	1	1054.45	1080	2149.06	1598.4	272	5.491	.995	.712	3.9-3
19	M19	6X10	.657	0	1	.284	0	z	1	1054.45	1080	2149.06	1598.4	272	5.491	.995	.712	3.9-3
20	M20	6X10	.543	8	1	.277	8	z	1	1054.45	1080	2149.06	1598.4	272	5.491	.995	.712	3.9-3
21	M21	6X10	.917	10	1	.394	10	z	1	811.932	1080	2146.01	1598.4	272	6.139	.994	.549	3.9-3
22	M22	6X10	.558	0	1	.278	0	z	1	1054.45	1080	2149.06	1598.4	272	5.491	.995	.712	3.9-3
23	M23	6X10	.544	8	1	.274	8	z	1	1054.45	1080	2149.06	1598.4	272	5.491	.995	.712	3.9-3
24	M24	6X10	.544	0	1	.274	0	z	1	1054.45	1080	2149.06	1598.4	272	5.491	.995	.712	3.9-3
25	M25	6X10	.540	0	1	.249	0	z	1	1054.45	1080	2149.06	1598.4	272	5.491	.995	.712	3.9-3
26	M26	6X10	.543	8	1	.277	8	z	1	1054.45	1080	2149.06	1598.4	272	5.491	.995	.712	3.9-3
27	M27	6X10	.540	8	1	.249	8	z	1	1054.45	1080	2149.06	1598.4	272	5.491	.995	.712	3.9-3
28	M28	6X10	.558	0	1	.278	0	z	1	1054.45	1080	2149.06	1598.4	272	5.491	.995	.712	3.9-3
29	M29	6X10	.642	8	1	.282	8	z	1	1054.45	1080	2149.06	1598.4	272	5.491	.995	.712	3.9-3
30	M30	6X10	.917	0	1	.394	0	z	1	811.932	1080	2146.01	1598.4	272	6.139	.994	.549	3.9-3
31	M31	6X10	.657	0	1	.284	0	z	1	1054.45	1080	2149.06	1598.4	272	5.491	.995	.712	3.9-3
32	M32	6X10	.915	0	1	.365	0	z	1	811.932	1080	2146.01	1598.4	272	6.139	.994	.549	3.9-3

Floor Panels

Member	Shape	Co...	Loc[ft]	LC	Shea...	Lo...	D.	LC	Fc' [p...	Ft' [psi]	Fb1' [...]	Fb2' [...]	Fv [p...	RB	CL	CP	Eqn	
1	M4	2X6	.184	2	2	.120	2	z	2	477.437	1404	2032.19	2392	288	10.832	.977	.181	3.9-3
2	M2	2x8	1.241	8	2	.186	8	z	2	31.08	1296	1124.98	2208	288	24.873	.586	.012	3.9-3
3	M3	2x8	.152	2	2	.091	2	z	2	476.315	1296	1861.41	2208	288	12.437	.969	.189	3.9-3
4	M4A	2x8	1.241	8	2	.186	8	z	2	31.08	1296	1124.98	2208	288	24.873	.586	.012	3.9-3
5	M5	2x8	1.241	8	2	.186	8	z	2	31.08	1296	1124.98	2208	288	24.873	.586	.012	3.9-3

Roof Panels

8	M8	2X10	1.184	2	2	.238	0	z	2	475.069	1188	1691.39	2112	288	14.048	.961	.198	3.9-3
9	M9	2X10	1.749	8	2	.100	16	z	2	31.076	1188	897.439	2112	288	28.095	.51	.013	3.9-3
10	M10	2X10	1.184	2	2	.238	0	z	2	475.069	1188	1691.39	2112	288	14.048	.961	.198	3.9-3
11	M11	2X10	1.749	8	2	.100	0	z	2	31.076	1188	897.439	2112	288	28.095	.51	.013	3.9-3
12	M12	2X10	1.749	8	2	.100	0	z	2	31.076	1188	897.439	2112	288	28.095	.51	.013	3.9-3

Appendix F: R-value breakdowns for walls and roof

Walls	
Material	R value
outside air	0.25
wood siding	1
2x2 16oc	0.09
airspace	0.86
plywood	0.93
Eps	7.61
2x4 16oc	0.41
plywood	0.93
inside air	0.68
R total	12.76
wall U	0.078

Roof	
Material	R value
outside air	0.25
plywood	0.93
2x10 16oc	1.11
Eps	20.66
plywood	0.93
inside air	0.68
r total	24.57
roof U	0.041

Appendix G: Cost and Labor Hours Estimate

The values used for unit cost were taken from RSMeans Construction Cost Data.

Item	Unit Cost	Quantity	Total Cost
6 x 10 Beams	\$1550/MBF	1.4 MBF	\$2,170
2 x 8 Joists	\$0.64/lf	672 ft	\$430
2 x 10 Joists	\$1.41/lf	672 ft	\$947
¾" Plywood	\$0.62/sf	3,584 ft ²	\$2,222
Wall SIP Panels	\$3.65/sf	1,440 ft ²	\$5,256
Total Cost of Wood			\$11,025

Item	Unit Labor Hours	Quantity	Labor Hours
6 x 10 Beams	14.54/MBF	1.4 MBF	20.35
2 x 8 Joists	0.025/lf	672 ft	16.8
2 x 10 Joists	0.027/lf	672 ft	18.14
¾" Plywood	0.011/sf	3,584 ft ²	39.42
Wall SIP Panels	0.019/sf	1,440 ft ²	27.36
Total Labor Hours			122 hours

Appendix H: Drawing Set

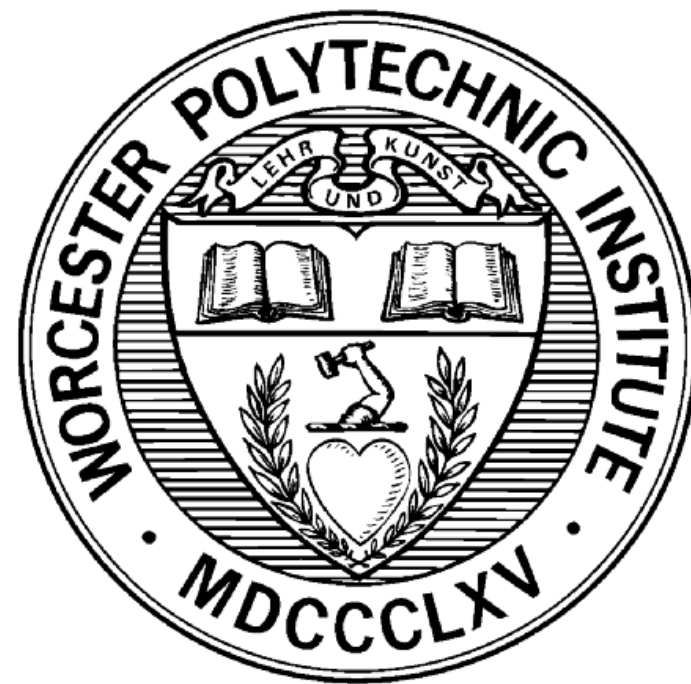

WORCESTER POLYTECHNIC INSTITUTE
DEPARTMENT OF ARCHITECTURAL ENGINEERING

PROJECT:



**SOLAR DECATHLON
AFRICA DESIGN
COMPETITION**

LOCATED IN MARRAKESH, MOROCCO

DESIGNED FOR KANO, NIGERIA

IN PARTNERSHIP WITH:

SIMPSON GUMPERTZ & HEGER

Engineering of Structures
and Building Enclosures

WALTHAM, MASSACHUSETTS

DESIGNED BY:

KELSEY LEIGHER
ARCHITECTURAL ENGINEER - STRUCTURAL

ALEXIS MOSER
ARCHITECTURAL ENGINEER - STRUCTURAL

HAYLEY POSKUS
CIVIL ENGINEER

PATRICK SCHENKENBERG
ARCHITECTURAL ENGINEER - MECHANICAL

ADVISED BY:

STEVEN VAN DESSEL
HEAD ADVISOR

SOROUGH FARZIN-MOGHADAM
ARCHITECTURAL ADVISOR

KENNETH M. ELOVITZ
MECHANICAL SYSTEMS ADVISOR

HUSSAM S. SALEEM
STRUCTURAL ENGINEERING ADVISOR

SHEET NAME:

**3D
RENDERING**

SHEET NUMBER:

A0.1

Sheet List	
Sheet Name	Sheet Number
3D RENDERING	A0.1
ARCHITECTURAL FLOOR PLAN	A1.0
ELEVATION	A2.0
ELEVATION	A2.1
ELEVATION/ SECTION	A2.2
ELEVATION/ SECTION	A2.3
FLOOR PANEL LAYOUT	A3.0
ROOF PANEL LAYOUT	A3.1
ARCHITECTURAL DETAILS	A4.0
ARCHITECTURAL DETAILS	A4.1
FLOOR FRAMING PLAN	S1.0

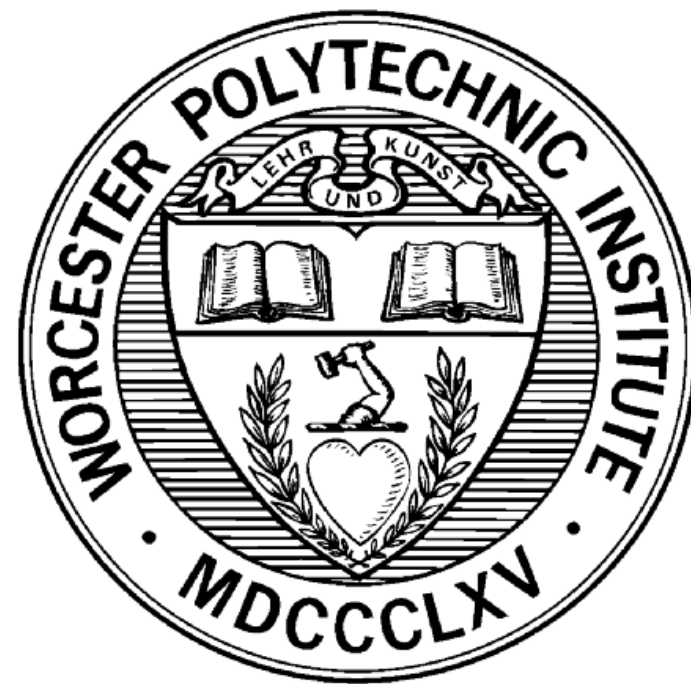

WORCESTER POLYTECHNIC INSTITUTE
DEPARTMENT OF ARCHITECTURAL ENGINEERING

PROJECT:



**SOLAR DECATHLON
AFRICA DESIGN
COMPETITION**

LOCATED IN MARRAKESH, MOROCCO
DESIGNED FOR KANO, NIGERIA

IN PARTNERSHIP WITH:



WALTHAM, MASSACHUSETTS

DESIGNED BY:

KELSEY LEIGHER
ARCHITECTURAL ENGINEER - STRUCTURAL

ALEXIS MOSER
ARCHITECTURAL ENGINEER - STRUCTURAL

HAYLEY POSKUS
CIVIL ENGINEER

PATRICK SCHENKENBERG
ARCHITECTURAL ENGINEER - MECHANICAL

ADVISED BY:

STEVEN VAN DESSEL
HEAD ADVISOR

SOROUGH FARZIN-MOGHADAM
ARCHITECTURAL ADVISOR

KENNETH M. ELOVITZ
MECHANICAL SYSTEMS ADVISOR

HUSSAM S. SALEEM
STRUCTURAL ENGINEERING ADVISOR

SHEET NAME:

**ARCHITECTURAL
FLOOR PLAN**

SHEET NUMBER:

A1.0

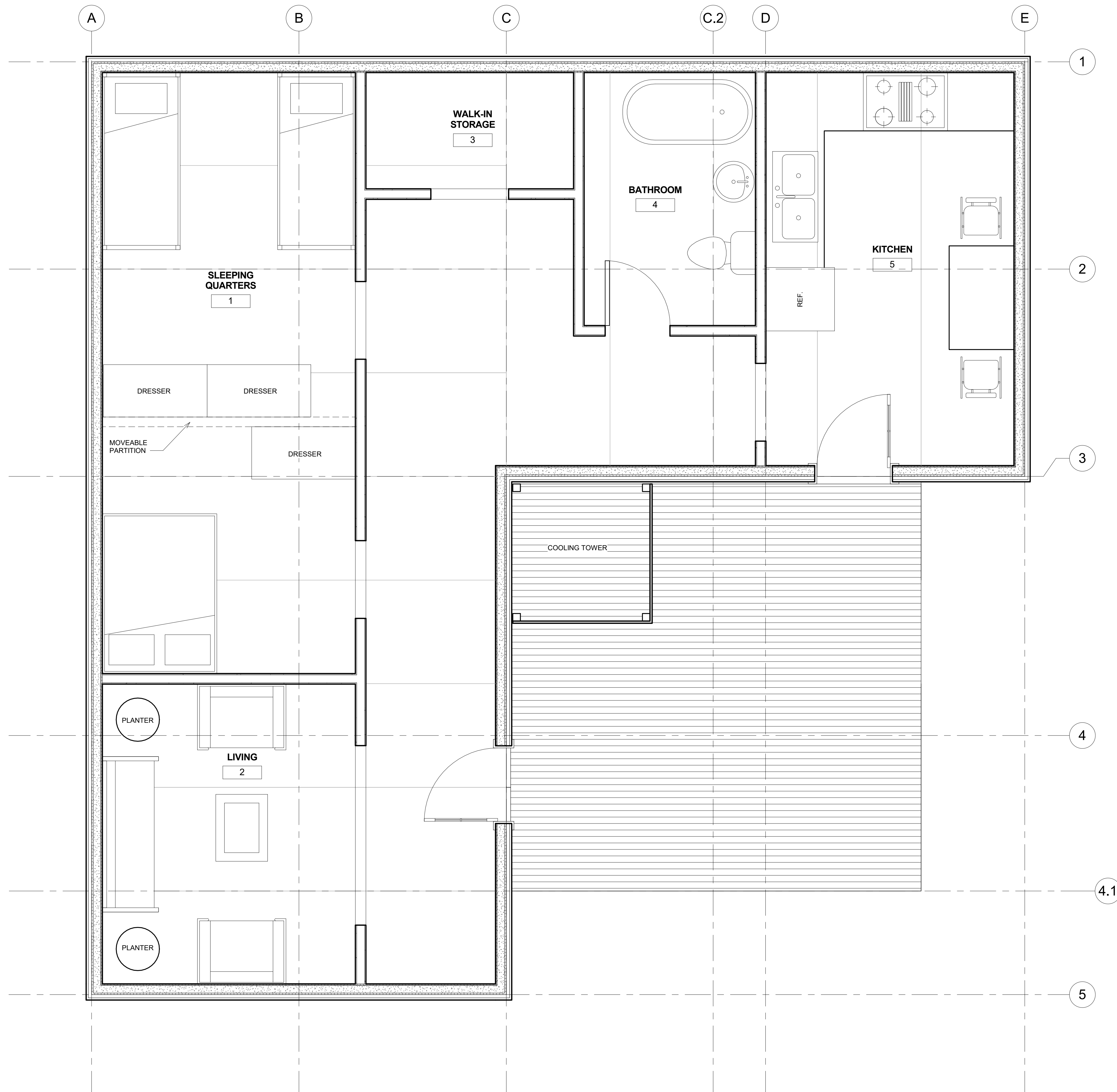

① FLOOR PLAN
1/2" = 1'-0"

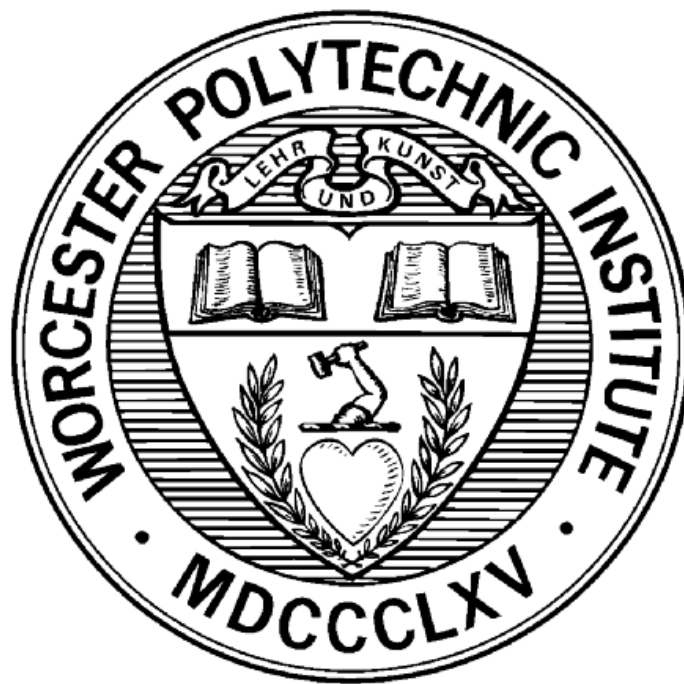

WORCESTER POLYTECHNIC INSTITUTE
DEPARTMENT OF ARCHITECTURAL ENGINEERING

PROJECT:



**SOLAR DECATHLON
AFRICA DESIGN
COMPETITION**

LOCATED IN MARRAKESH, MOROCCO
DESIGNED FOR KANO, NIGERIA

IN PARTNERSHIP WITH:



WALTHAM, MASSACHUSETTS

DESIGNED BY:

KELSEY LEIGHER
ARCHITECTURAL ENGINEER - STRUCTURAL

ALEXIS MOSER
ARCHITECTURAL ENGINEER - STRUCTURAL

HAYLEY POSKUS
CIVIL ENGINEER

PATRICK SCHENKENBERG
ARCHITECTURAL ENGINEER - MECHANICAL

ADVISED BY:

STEVEN VAN DESSEL
HEAD ADVISOR

SOROUGH FARZIN-MOGHADAM
ARCHITECTURAL ADVISOR

KENNETH M. ELOVITZ
MECHANICAL SYSTEMS ADVISOR

HUSSAM S. SALEEM
STRUCTURAL ENGINEERING ADVISOR

SHEET NAME:

ELEVATION

SHEET NUMBER:

A2.0

E

D

C.2

C.1

C

B

A

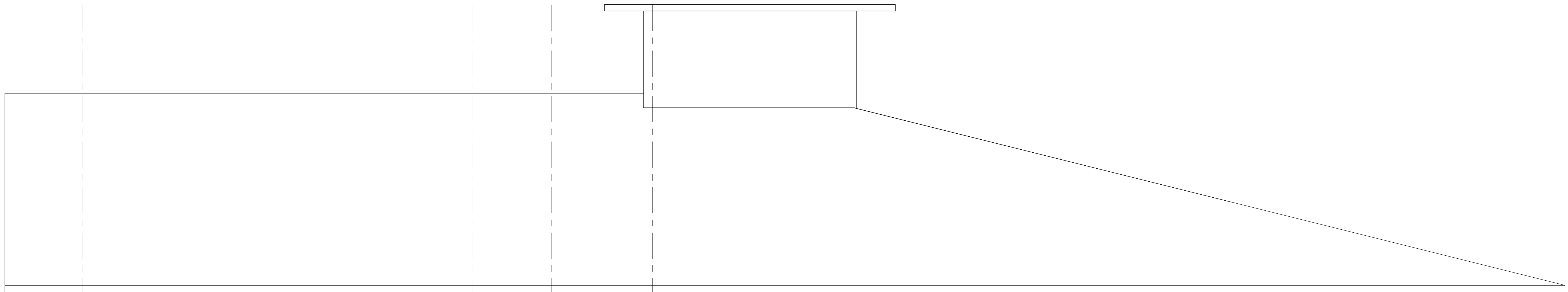

B/CEILING
10' - 0"

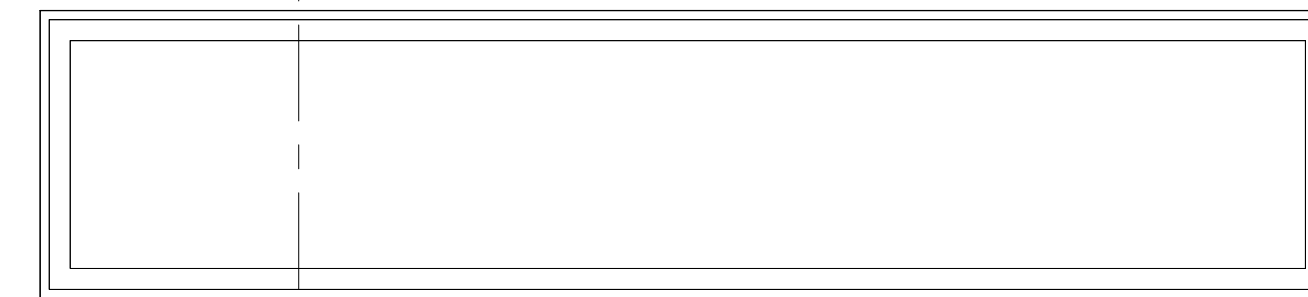
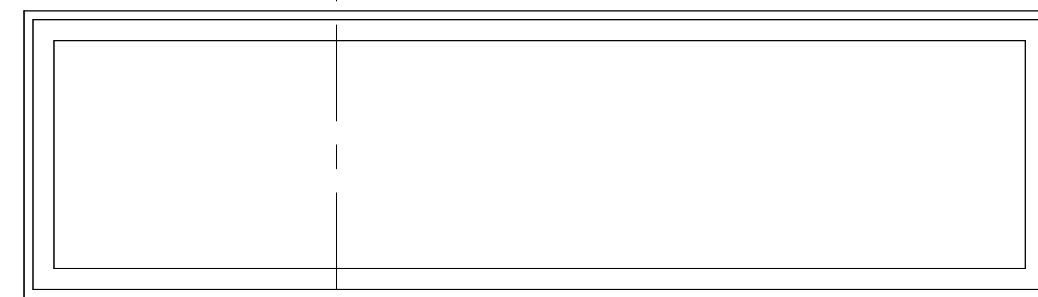
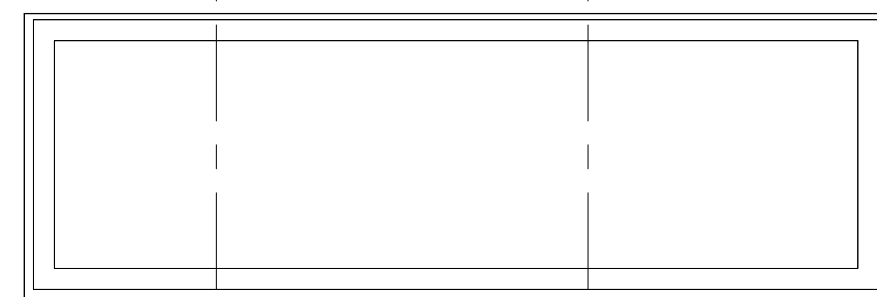
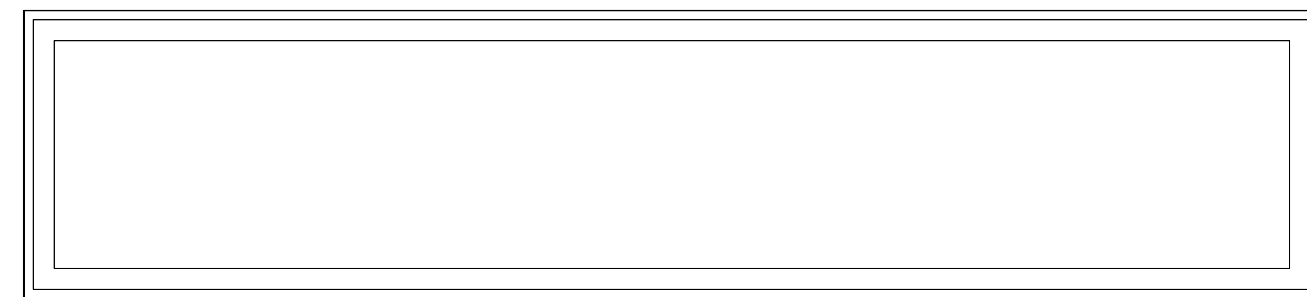

T/FLOOR
0' - 0"

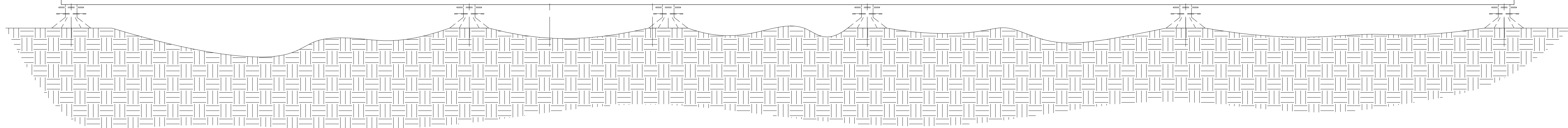

1 NORTH ELEVATION
3/4" = 1'-0"

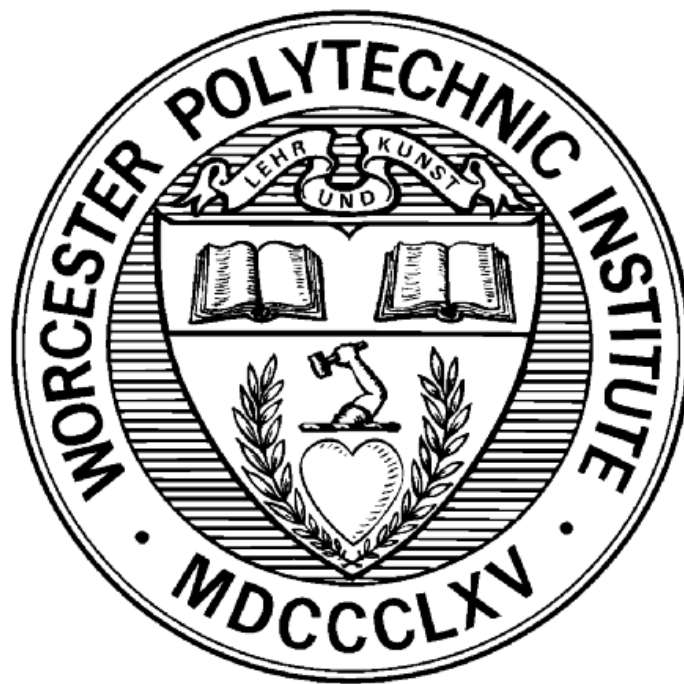

WORCESTER POLYTECHNIC INSTITUTE
DEPARTMENT OF ARCHITECTURAL ENGINEERING

PROJECT:



**SOLAR DECATHLON
AFRICA DESIGN
COMPETITION**

LOCATED IN MARRAKESH, MOROCCO
DESIGNED FOR KANO, NIGERIA

IN PARTNERSHIP WITH:



WALTHAM, MASSACHUSETTS

DESIGNED BY:

KELSEY LEIGHER
ARCHITECTURAL ENGINEER - STRUCTURAL

ALEXIS MOSER
ARCHITECTURAL ENGINEER - STRUCTURAL

HAYLEY POSKUS
CIVIL ENGINEER

PATRICK SCHENKENBERG
ARCHITECTURAL ENGINEER - MECHANICAL

ADVISED BY:

STEVEN VAN DESSEL
HEAD ADVISOR

SOROUGH FARZIN-MOGHADAM
ARCHITECTURAL ADVISOR

KENNETH M. ELOVITZ
MECHANICAL SYSTEMS ADVISOR

HUSSAM S. SALEEM
STRUCTURAL ENGINEERING ADVISOR

SHEET NAME:

ELEVATION

SHEET NUMBER:

A2.1

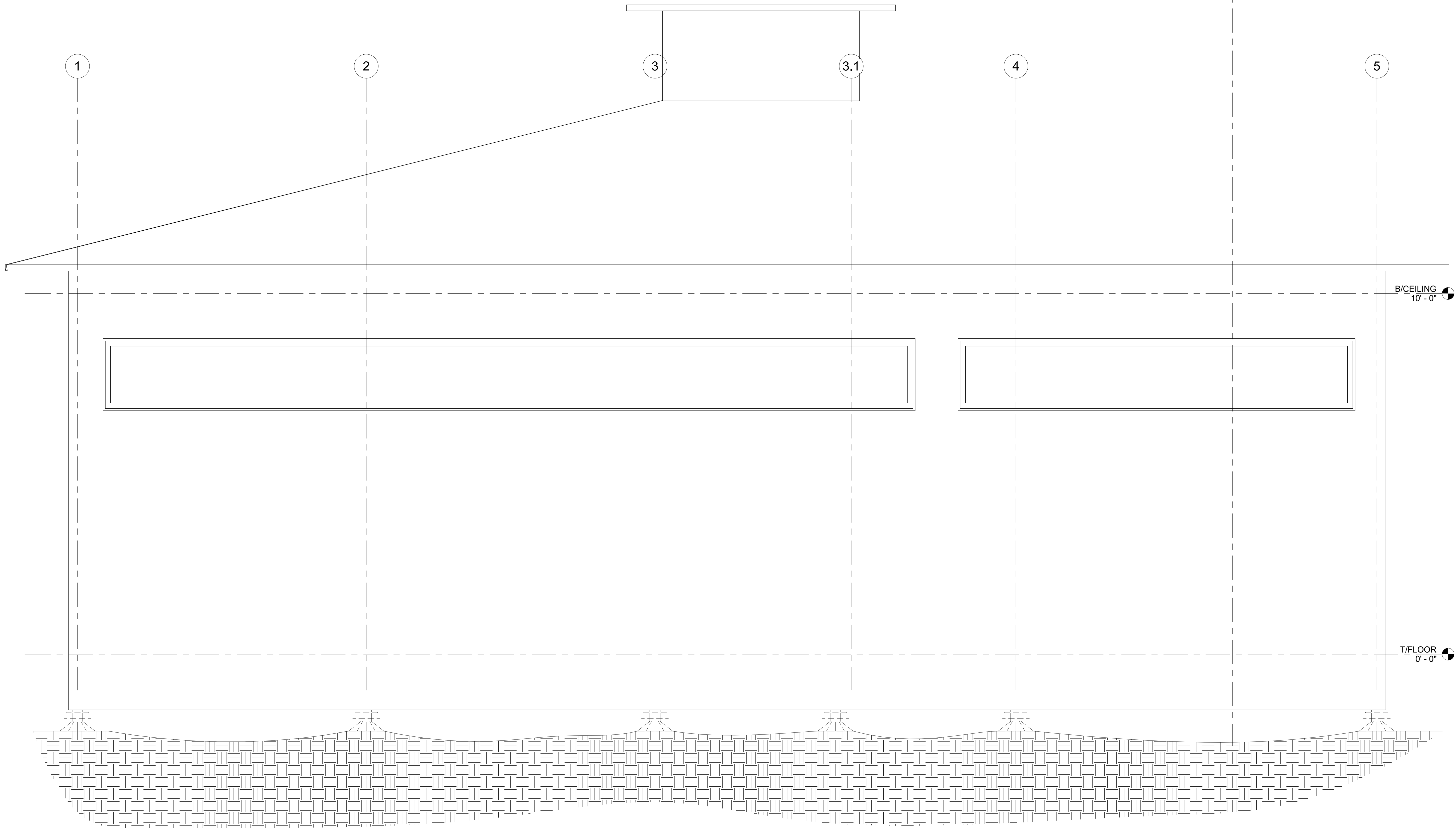

1 WEST ELEVATION
3/4" = 1'-0"

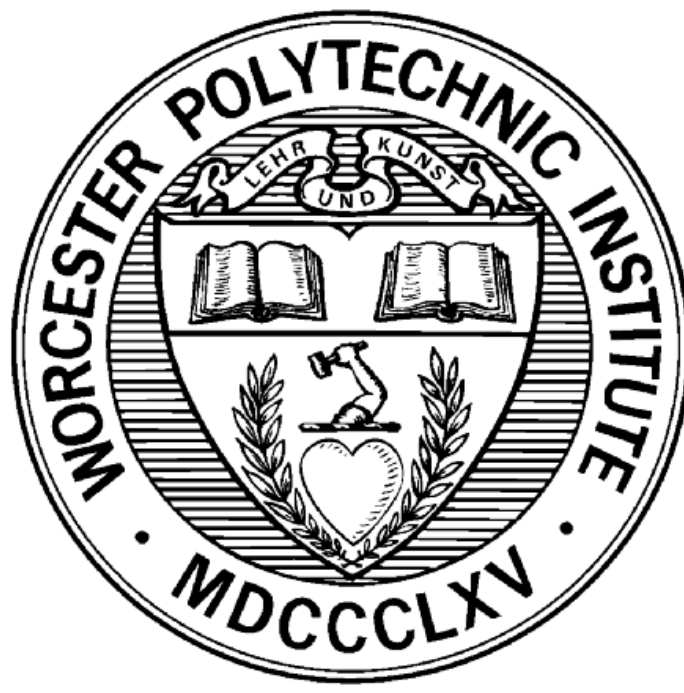

WORCESTER POLYTECHNIC INSTITUTE
DEPARTMENT OF ARCHITECTURAL ENGINEERING

PROJECT:



**SOLAR DECATHLON
AFRICA DESIGN
COMPETITION**

LOCATED IN MARRAKESH, MOROCCO
DESIGNED FOR KANO, NIGERIA

IN PARTNERSHIP WITH:



WALTHAM, MASSACHUSETTS

DESIGNED BY:

KELSEY LEIGHER
ARCHITECTURAL ENGINEER - STRUCTURAL

ALEXIS MOSER
ARCHITECTURAL ENGINEER - STRUCTURAL

HAYLEY POSKUS
CIVIL ENGINEER

PATRICK SCHENKENBERG
ARCHITECTURAL ENGINEER - MECHANICAL

ADVISED BY:

STEVEN VAN DESSEL
HEAD ADVISOR

SOROUGH FARZIN-MOGHADAM
ARCHITECTURAL ADVISOR

KENNETH M. ELOVITZ
MECHANICAL SYSTEMS ADVISOR

HUSSAM S. SALEEM
STRUCTURAL ENGINEERING ADVISOR

SHEET NAME:

**ELEVATION/
SECTION**

SHEET NUMBER:

A2.2

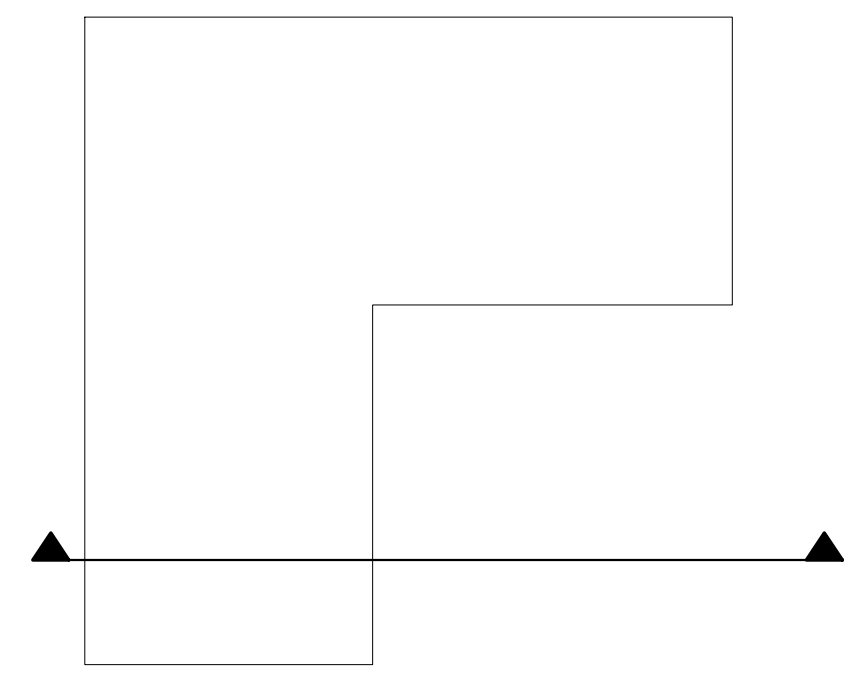

SECTION 1 KEY
3/32" = 1'-0"

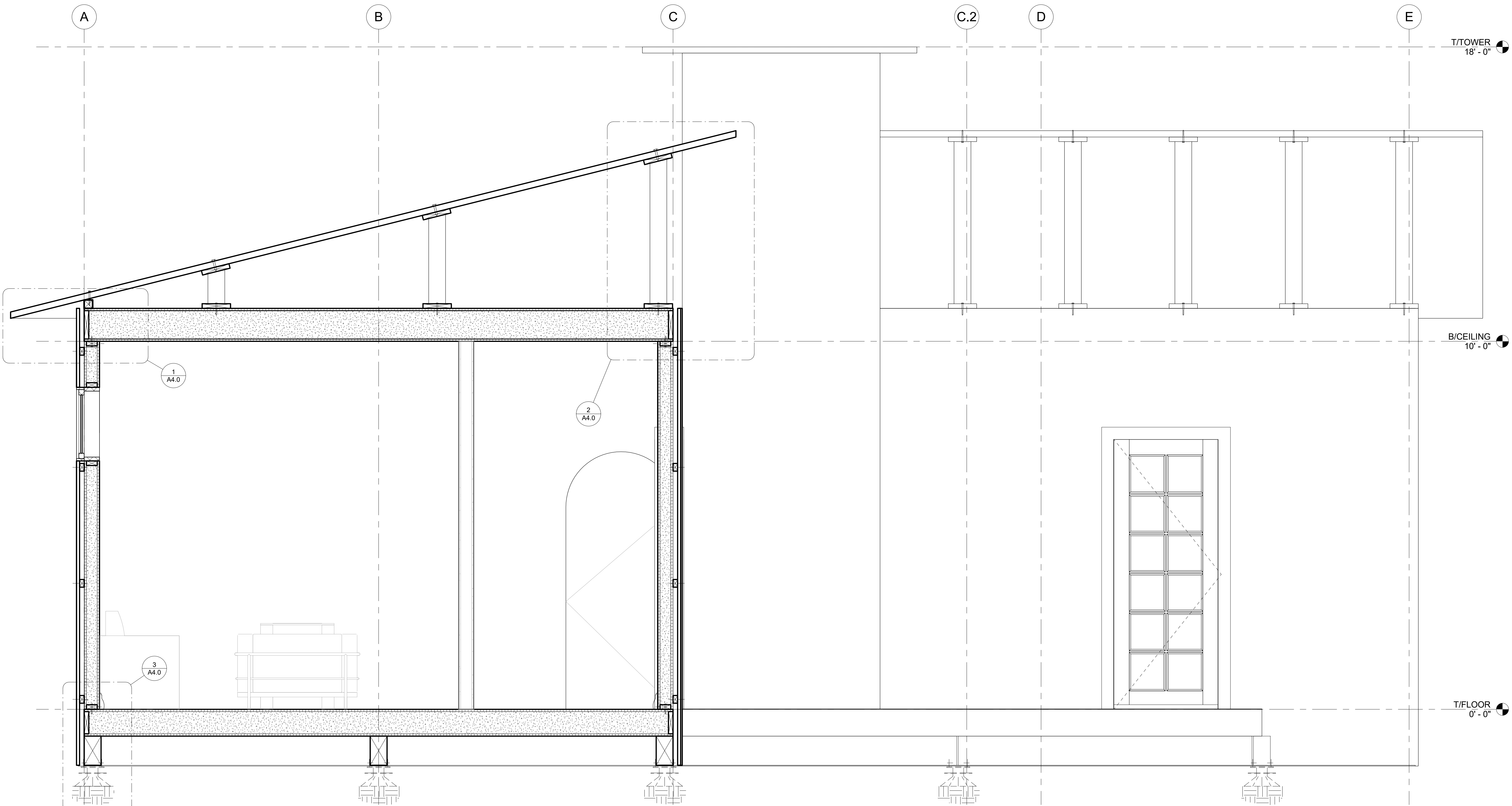

BUILDING SECTION / SOUTH ELEVATION
3/4" = 1'-0"

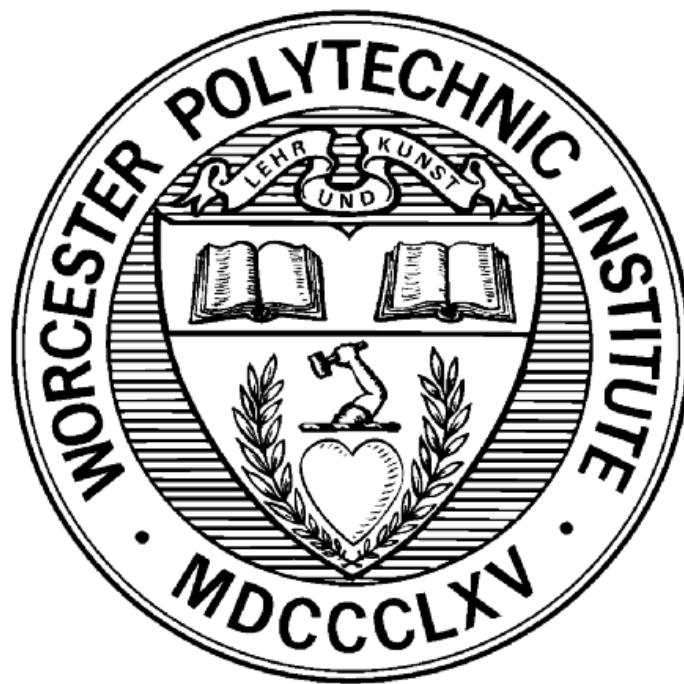

WORCESTER POLYTECHNIC INSTITUTE
DEPARTMENT OF ARCHITECTURAL ENGINEERING

PROJECT:



**SOLAR DECATHLON
AFRICA DESIGN
COMPETITION**

LOCATED IN MARRAKESH, MOROCCO
DESIGNED FOR KANO, NIGERIA

IN PARTNERSHIP WITH:



WALTHAM, MASSACHUSETTS

DESIGNED BY:

- KELSEY LEIGHER**
ARCHITECTURAL ENGINEER - STRUCTURAL
- ALEXIS MOSER**
ARCHITECTURAL ENGINEER - STRUCTURAL
- HAYLEY POSKUS**
CIVIL ENGINEER
- PATRICK SCHENKENBERG**
ARCHITECTURAL ENGINEER - MECHANICAL

ADVISED BY:

- STEVEN VAN DESSEL**
HEAD ADVISOR
- SOROUGH FARZIN-MOGHADAM**
ARCHITECTURAL ADVISOR
- KENNETH M. ELOVITZ**
MECHANICAL SYSTEMS ADVISOR
- HUSSAM S. SALEEM**
STRUCTURAL ENGINEERING ADVISOR

SHEET NAME:

**ELEVATION/
SECTION**

SHEET NUMBER:

A2.3

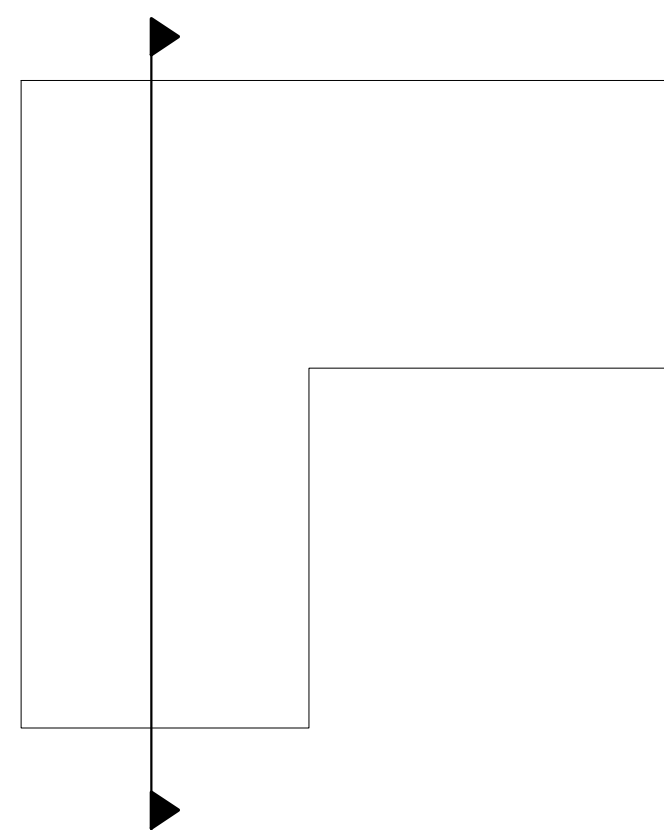

② SECTION 2 KEY
3/32" = 1'-0"

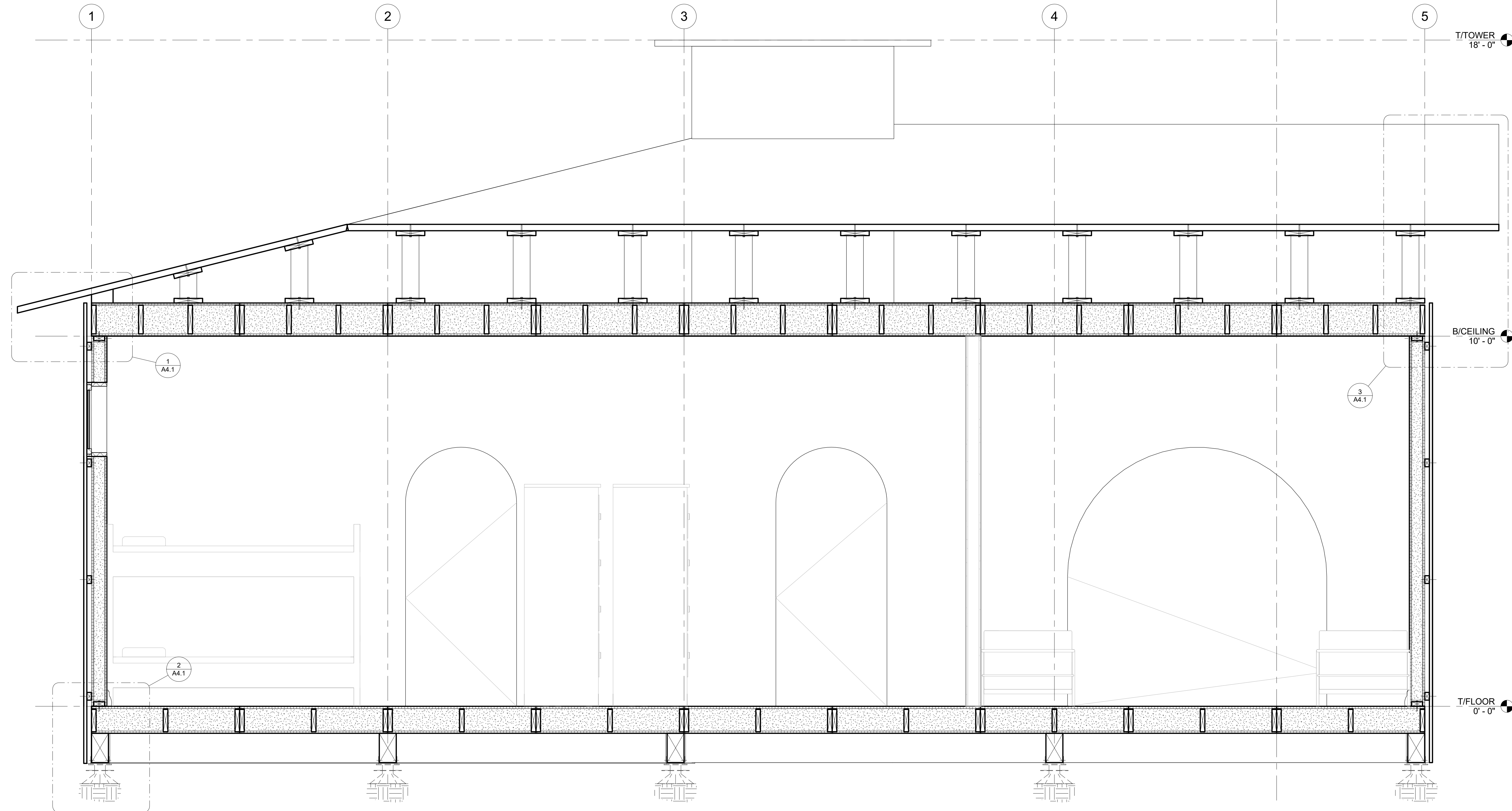

① WEST BUILDING SECTION
3/4" = 1'-0"

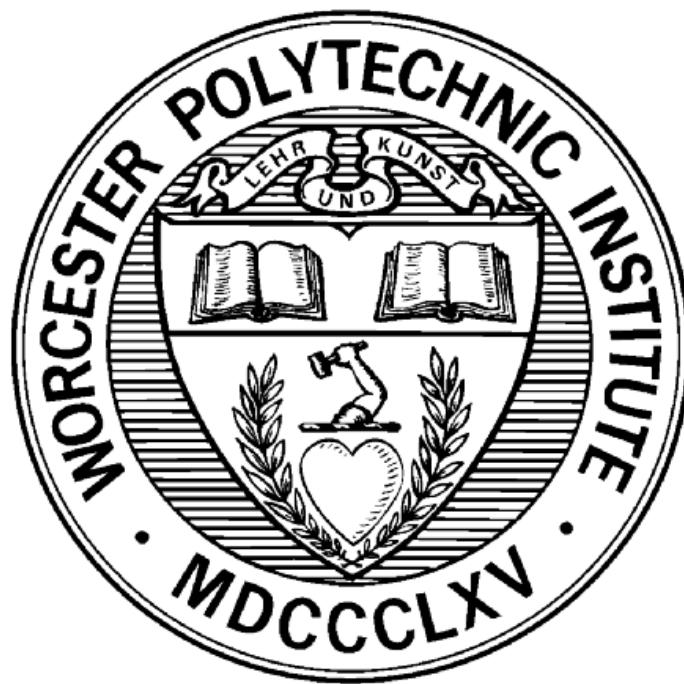

WORCESTER POLYTECHNIC INSTITUTE
DEPARTMENT OF ARCHITECTURAL ENGINEERING

PROJECT:



**SOLAR DECATHLON
AFRICA DESIGN
COMPETITION**

LOCATED IN MARRAKESH, MOROCCO
DESIGNED FOR KANO, NIGERIA

IN PARTNERSHIP WITH:



WALTHAM, MASSACHUSETTS

DESIGNED BY:

KELSEY LEIGHER
ARCHITECTURAL ENGINEER - STRUCTURAL

ALEXIS MOSER
ARCHITECTURAL ENGINEER - STRUCTURAL

HAYLEY POSKUS
CIVIL ENGINEER

PATRICK SCHENKENBERG
ARCHITECTURAL ENGINEER - MECHANICAL

ADVISED BY:

STEVEN VAN DESSEL
HEAD ADVISOR

SOROUGH FARZIN-MOGHADAM
ARCHITECTURAL ADVISOR

KENNETH M. ELOVITZ
MECHANICAL SYSTEMS ADVISOR

HUSSAM S. SALEEM
STRUCTURAL ENGINEERING ADVISOR

SHEET NAME:

**FLOOR
PANEL
LAYOUT**

SHEET NUMBER:

A3.0

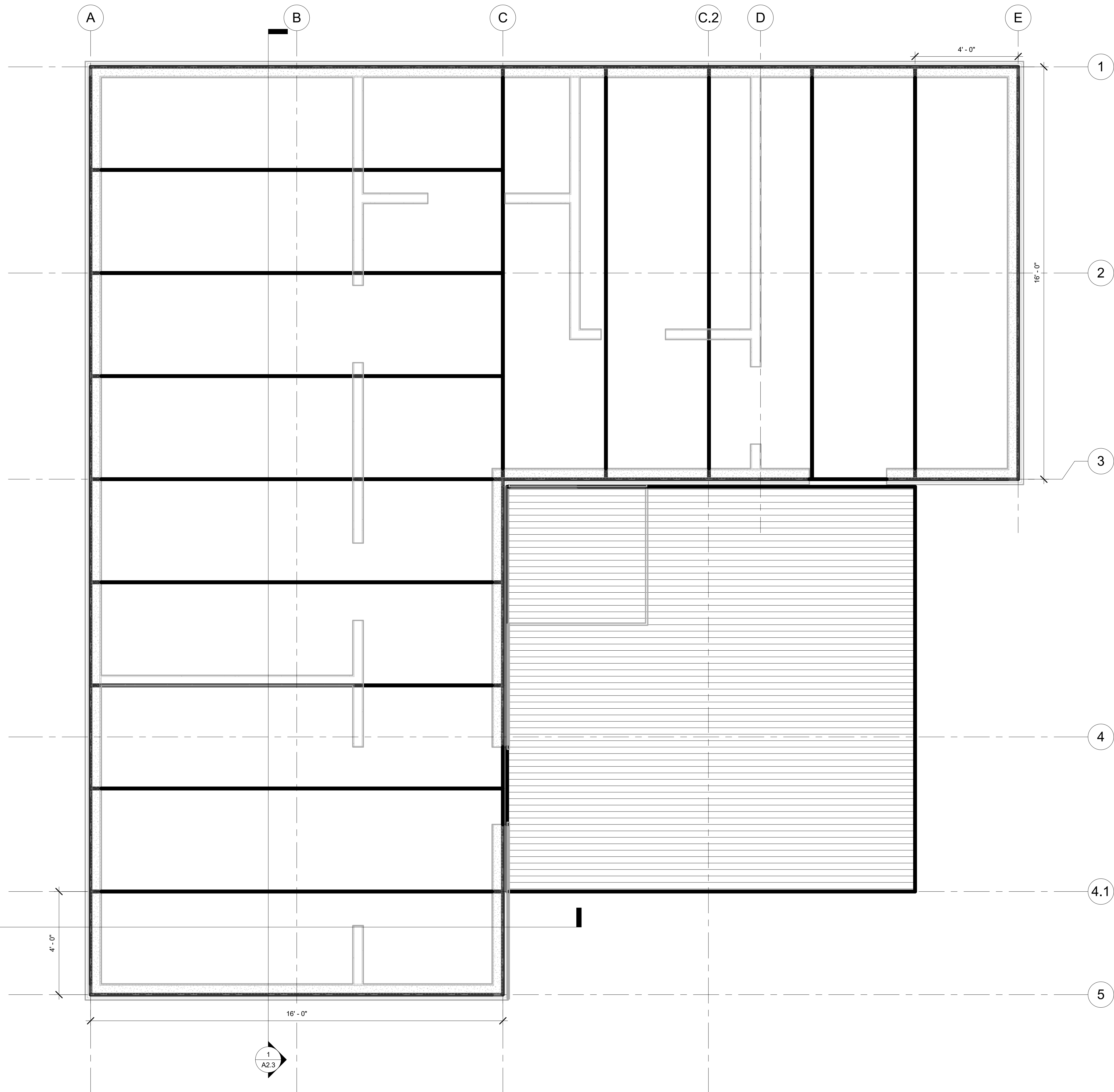

① FLOOR PANEL LAYOUT
1/2" = 1'-0"

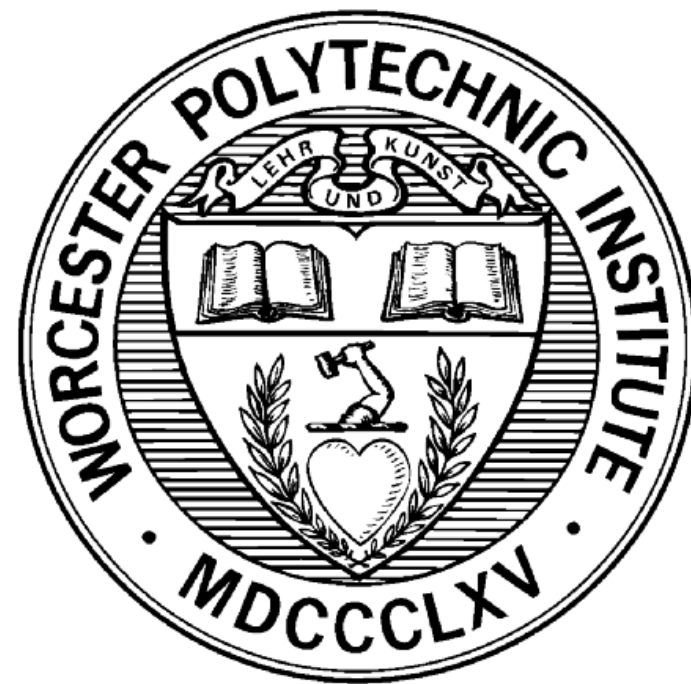

WORCESTER POLYTECHNIC INSTITUTE
DEPARTMENT OF ARCHITECTURAL ENGINEERING

PROJECT:



**SOLAR DECATHLON
AFRICA DESIGN
COMPETITION**

LOCATED IN MARRAKESH, MOROCCO

DESIGNED FOR KANO, NIGERIA

IN PARTNERSHIP WITH:

SIMPSON GUMPERTZ & HEGER

Engineering of Structures
and Building Enclosures

WALTHAM, MASSACHUSETTS

DESIGNED BY:

KELSEY LEIGHER
ARCHITECTURAL ENGINEER - STRUCTURAL

ALEXIS MOSER
ARCHITECTURAL ENGINEER - STRUCTURAL

HAYLEY POSKUS
CIVIL ENGINEER

PATRICK SCHENKENBERG
ARCHITECTURAL ENGINEER - MECHANICAL

ADVISED BY:

STEVEN VAN DESSEL
HEAD ADVISOR

SOROUSH FARZIN-MOGHADAM
ARCHITECTURAL ADVISOR

KENNETH M. ELOVITZ
MECHANICAL SYSTEMS ADVISOR

HUSSAM S. SALEEM
STRUCTURAL ENGINEERING ADVISOR

SHEET NAME:

**ROOF PANEL
LAYOUT**

SHEET NUMBER:

A3.1

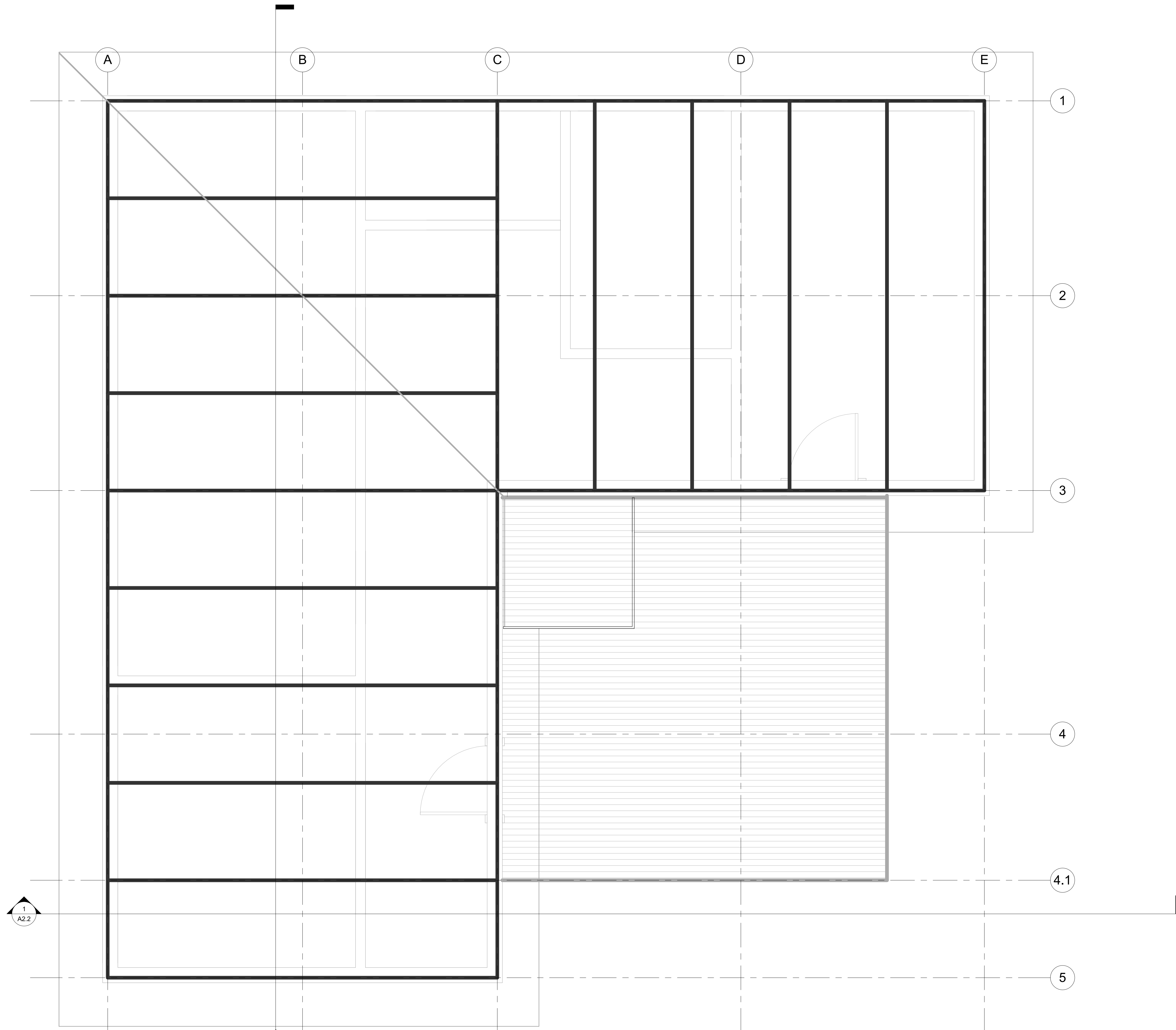

1 ROOF PANEL LAYOUT
1/2" = 1'-0"

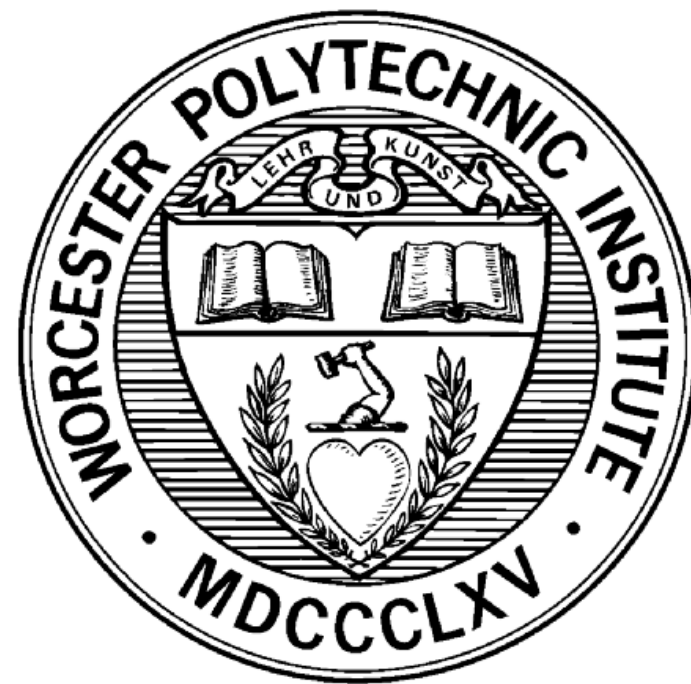

WORCESTER POLYTECHNIC INSTITUTE
DEPARTMENT OF ARCHITECTURAL ENGINEERING

PROJECT:



SOLAR DECATHLON
AFRICA DESIGN
COMPETITION

LOCATED IN MARRAKESH, MOROCCO
DESIGNED FOR KANO, NIGERIA

IN PARTNERSHIP WITH:



WALTHAM, MASSACHUSETTS

DESIGNED BY:

KELSEY LEIGHER
ARCHITECTURAL ENGINEER - STRUCTURAL

ALEXIS MOSER
ARCHITECTURAL ENGINEER - STRUCTURAL

HAYLEY POSKUS
CIVIL ENGINEER

PATRICK SCHENKENBERG
ARCHITECTURAL ENGINEER - MECHANICAL

ADVISED BY:

STEVEN VAN DESSEL
HEAD ADVISOR

SOROUGH FARZIN-MOGHADAM
ARCHITECTURAL ADVISOR

KENNETH M. ELOVITZ
MECHANICAL SYSTEMS ADVISOR

HUSSAM S. SALEEM
STRUCTURAL ENGINEERING ADVISOR

SHEET NAME:

ARCHITECTURAL
DETAILS

SHEET NUMBER:

A4.0

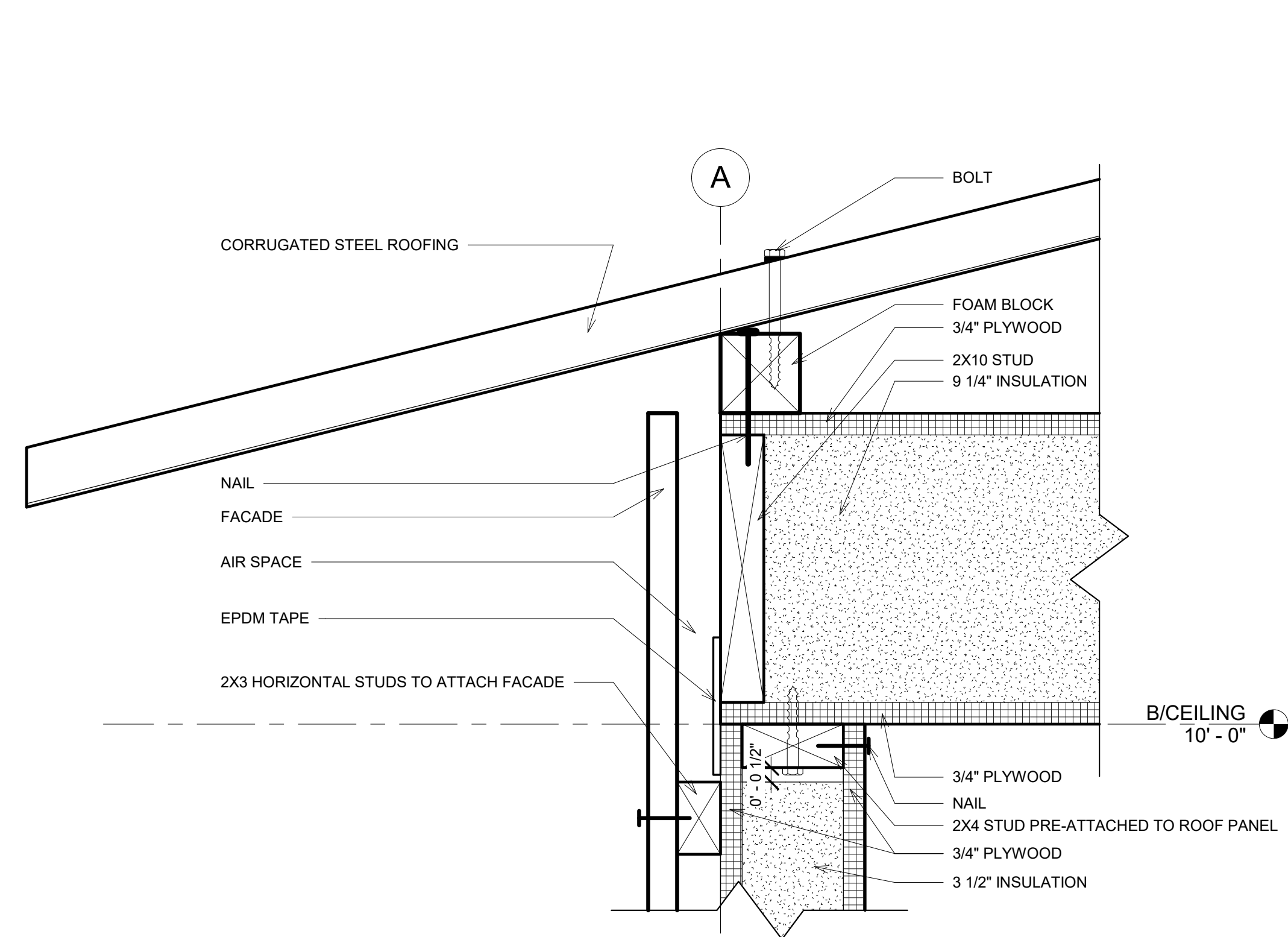

① LOW CORNER DETAIL - SOUTH
3" = 1'-0"

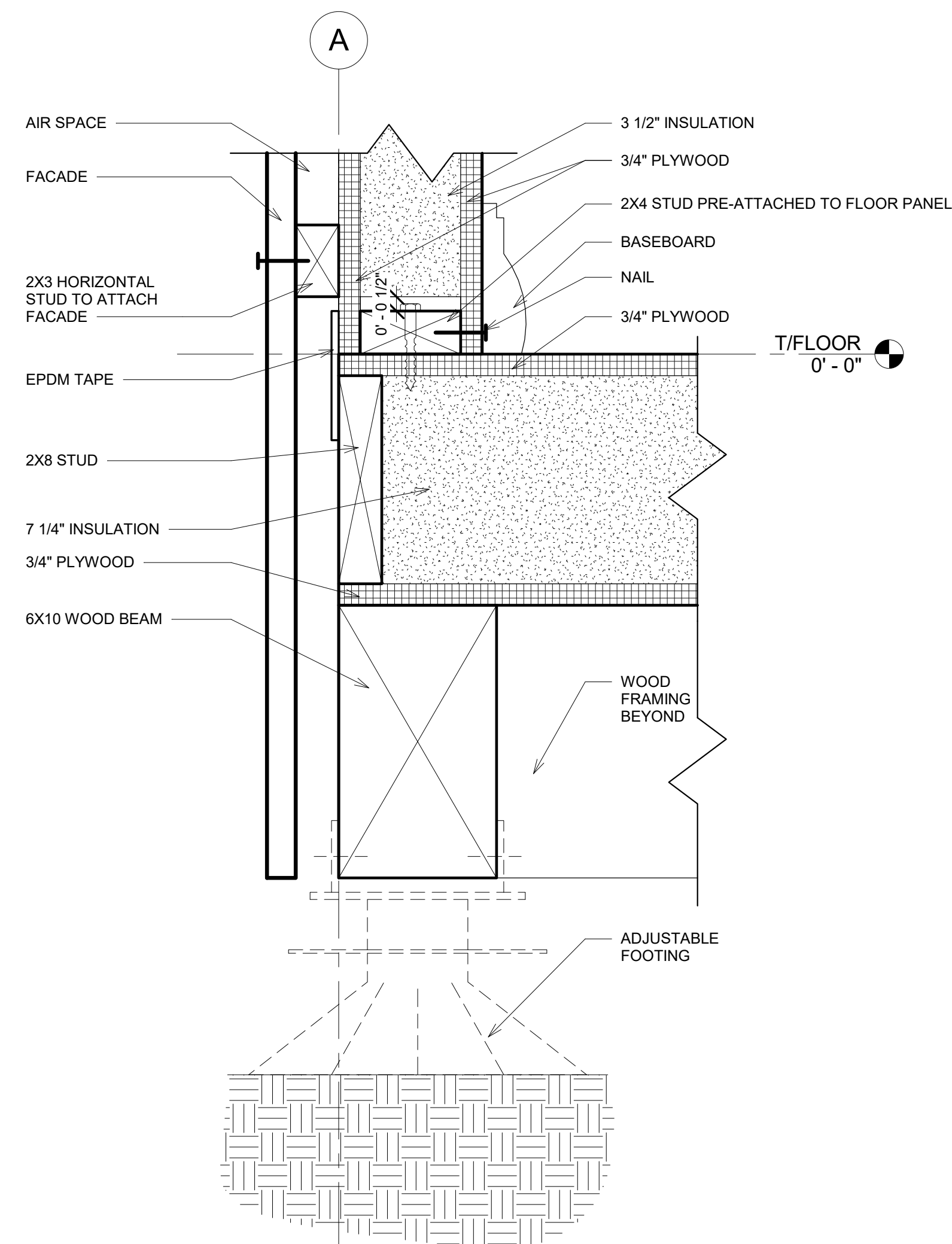

③ BOTTOM CORNER DETAIL - SOUTH
3" = 1'-0"

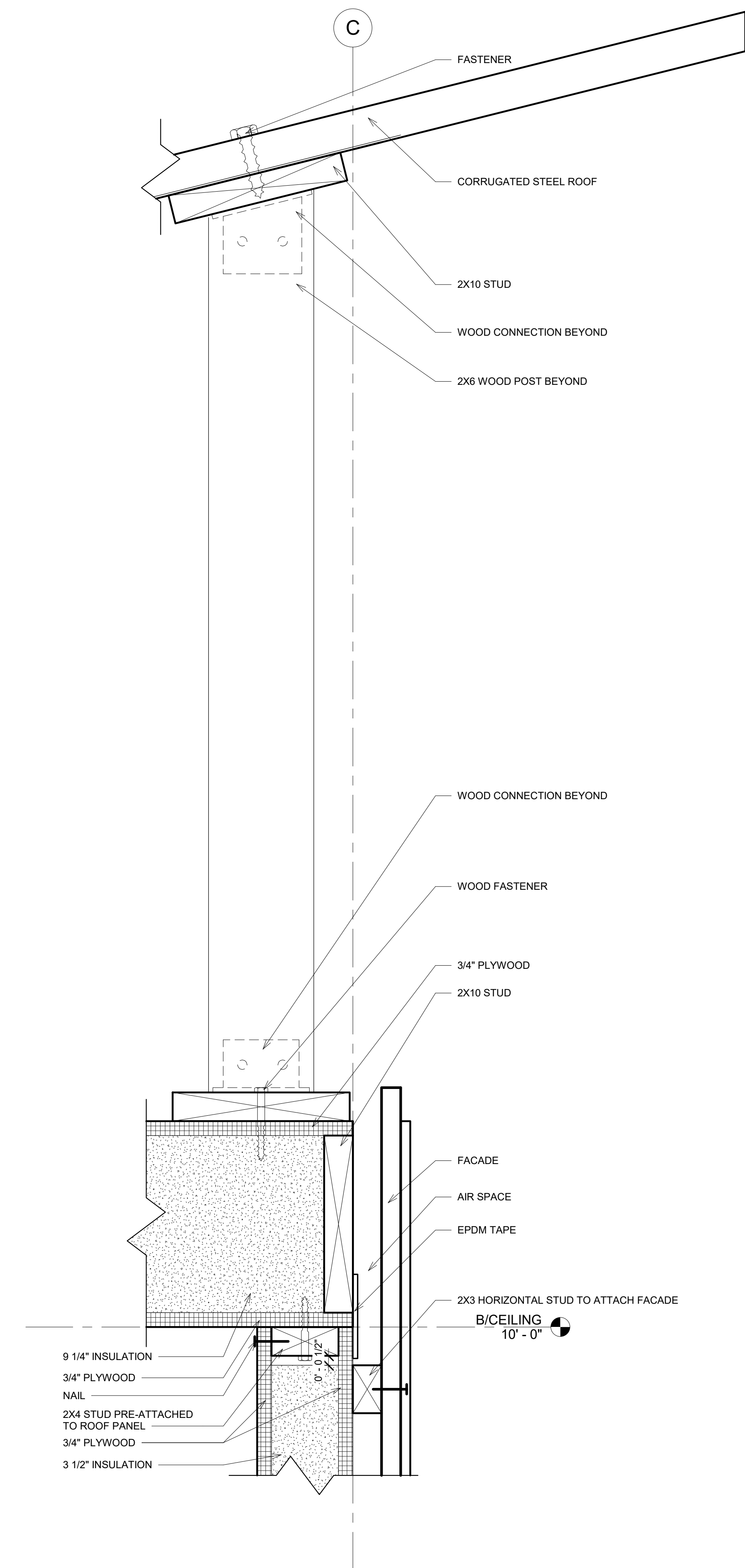

② HIGH CORNER DETAIL - SOUTH
3" = 1'-0"

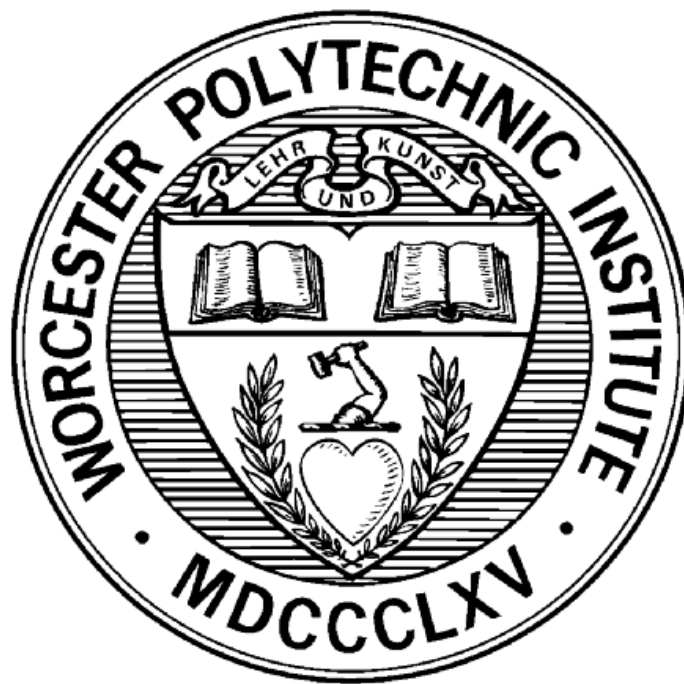

WORCESTER POLYTECHNIC INSTITUTE
DEPARTMENT OF ARCHITECTURAL ENGINEERING



**SOLAR DECATHLON
AFRICA DESIGN
COMPETITION**

LOCATED IN MARRAKESH, MOROCCO
DESIGNED FOR KANO, NIGERIA



DESIGNED BY:
KELSEY LEIGHER
ARCHITECTURAL ENGINEER - STRUCTURAL
ALEXIS MOSER
ARCHITECTURAL ENGINEER - STRUCTURAL
HAYLEY POSKUS
CIVIL ENGINEER
PATRICK SCHENKENBERG
ARCHITECTURAL ENGINEER - MECHANICAL

ADVISED BY:
STEVEN VAN DESSEL
HEAD ADVISOR
SOROUGH FARZIN-MOGHADAM
ARCHITECTURAL ADVISOR
KENNETH M. ELOVITZ
MECHANICAL SYSTEMS ADVISOR
HUSSAM S. SALEEM
STRUCTURAL ENGINEERING ADVISOR

SHEET NAME:
**ARCHITECTURAL
DETAILS**

SHEET NUMBER:

A4.1

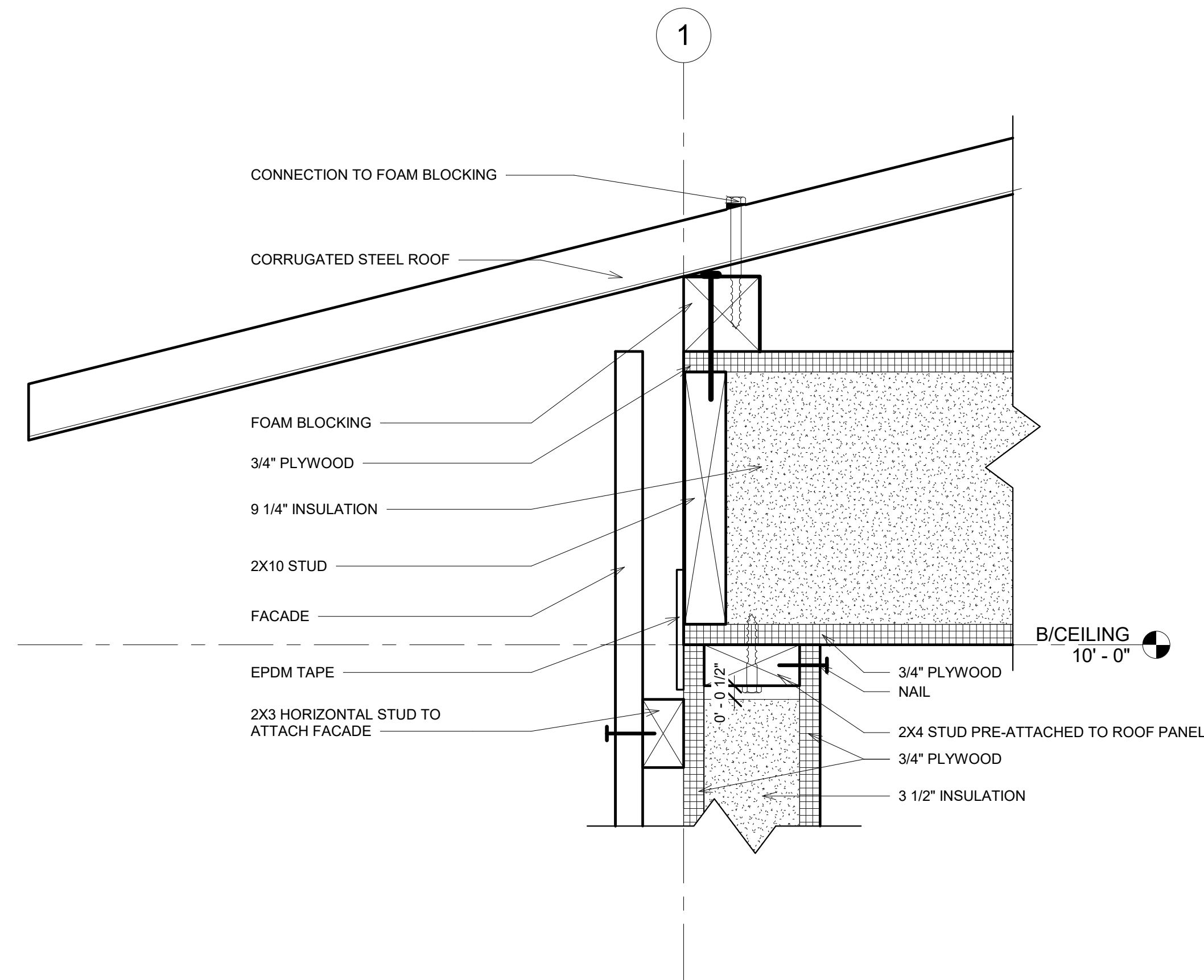

1 LOW CORNER DETAIL - WEST
3" = 1'-0"

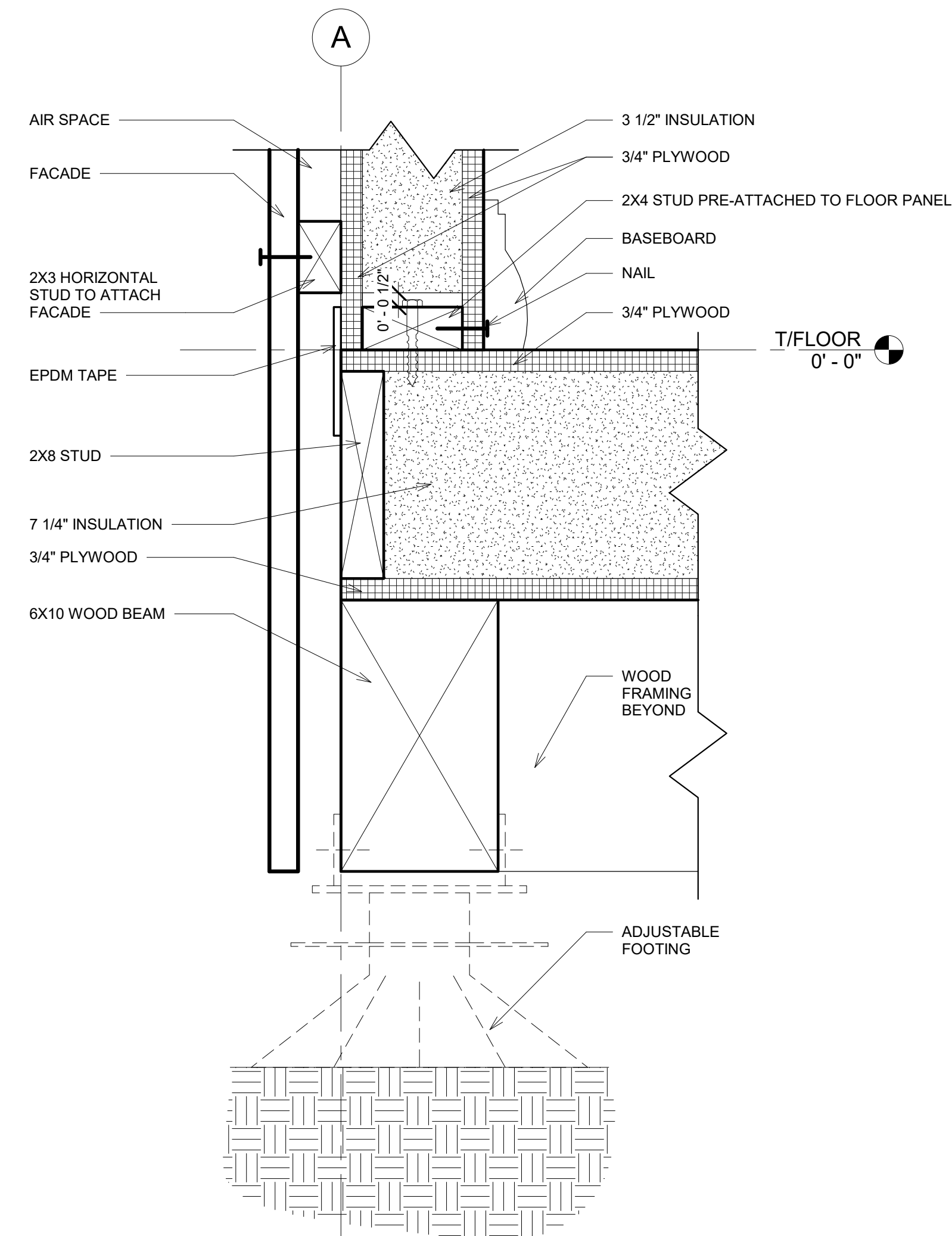

2 BOTTOM CORNER DETAIL - WEST
3" = 1'-0"

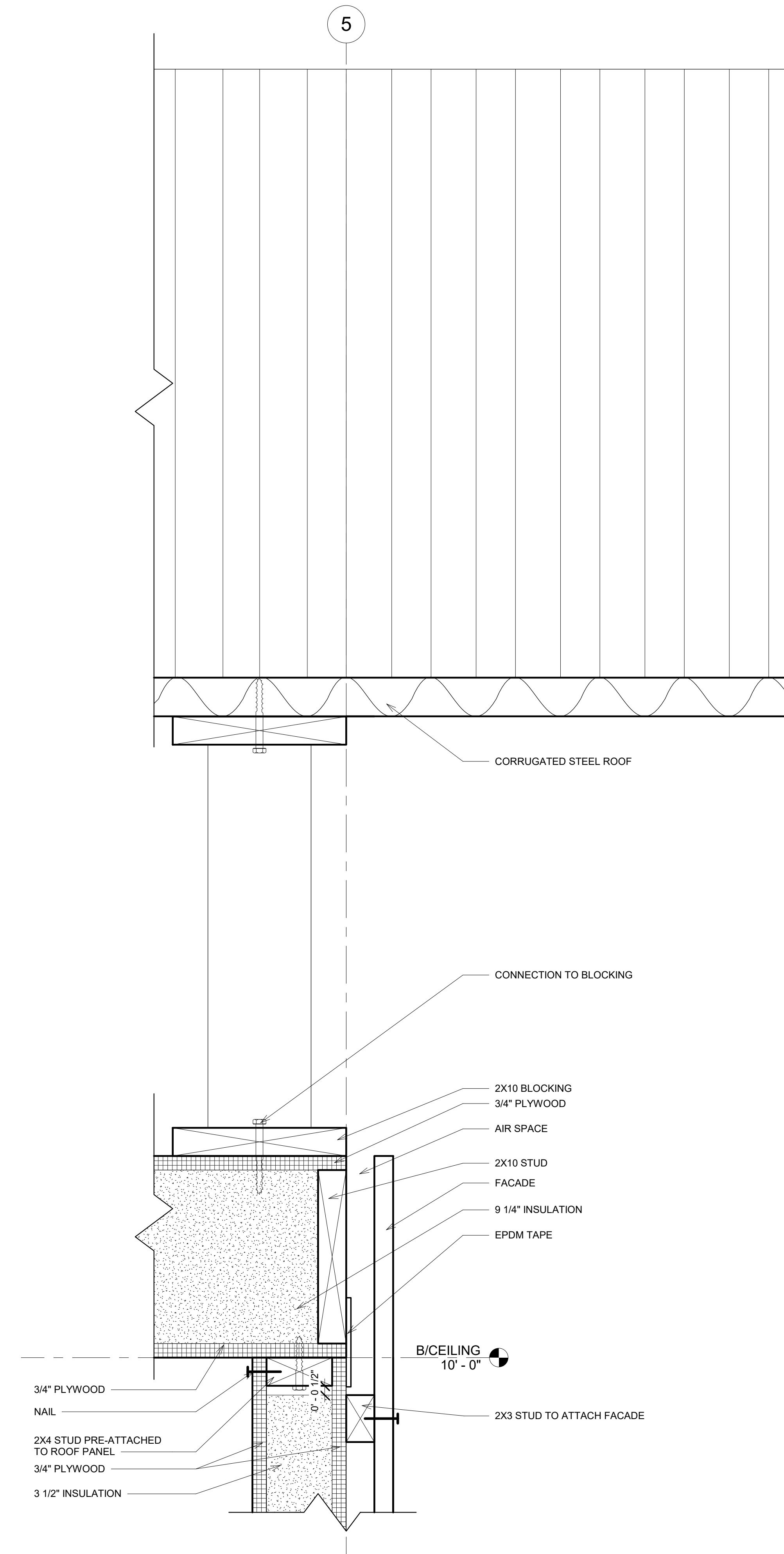

3 HIGH CORNER DETAIL - WEST
3" = 1'-0"

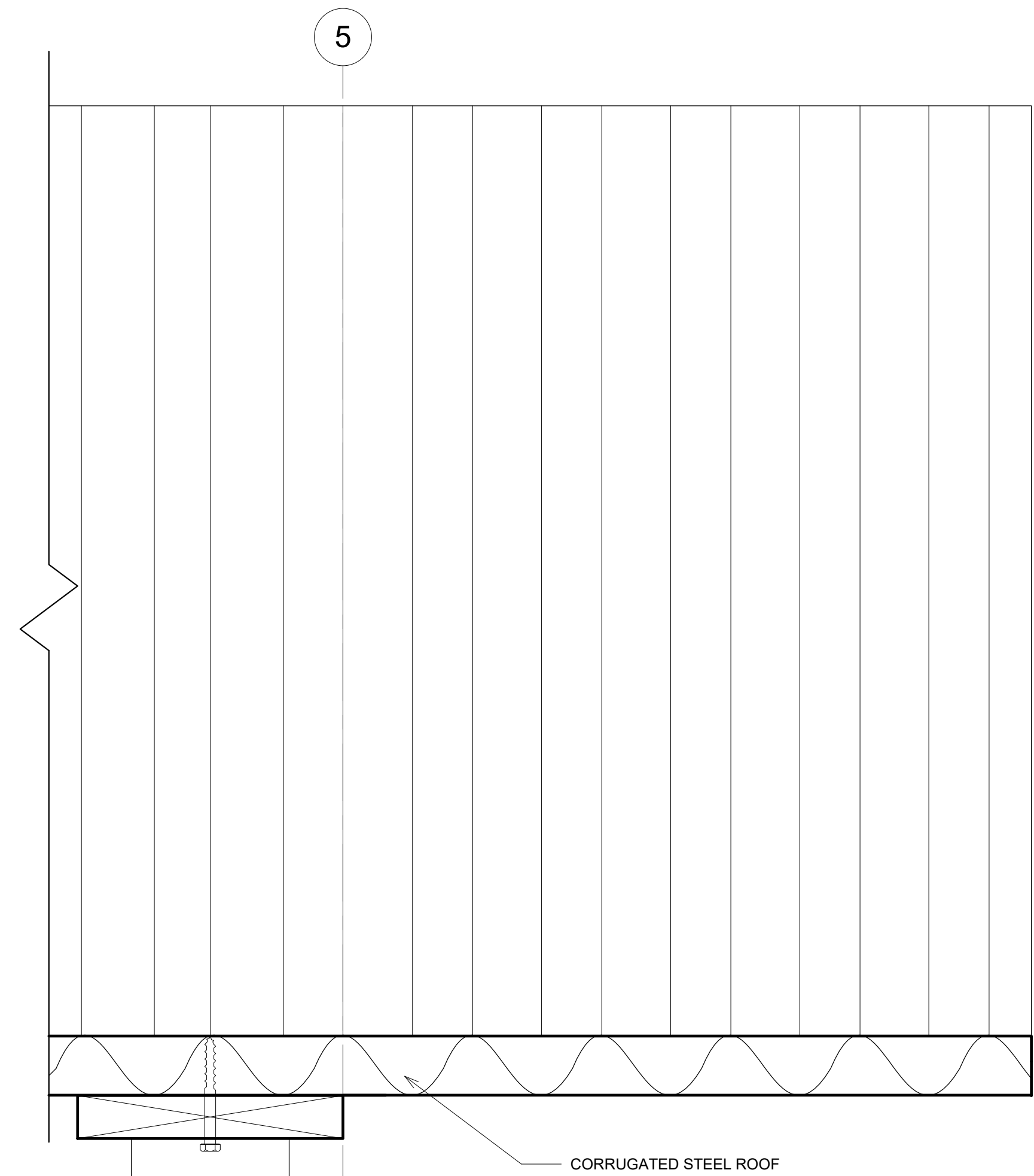

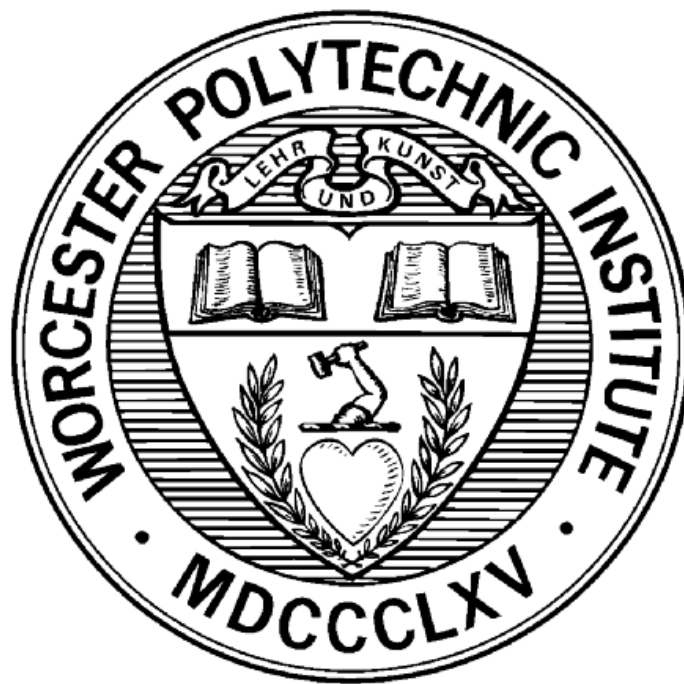

WORCESTER POLYTECHNIC INSTITUTE
DEPARTMENT OF ARCHITECTURAL ENGINEERING

PROJECT:



**SOLAR DECATHLON
AFRICA DESIGN
COMPETITION**

LOCATED IN MARRAKESH, MOROCCO
DESIGNED FOR KANO, NIGERIA

IN PARTNERSHIP WITH:



WALTHAM, MASSACHUSETTS

DESIGNED BY:

- KELSEY LEIGHER**
ARCHITECTURAL ENGINEER - STRUCTURAL
- ALEXIS MOSER**
ARCHITECTURAL ENGINEER - STRUCTURAL
- HAYLEY POSKUS**
CIVIL ENGINEER
- PATRICK SCHENKENBERG**
ARCHITECTURAL ENGINEER - MECHANICAL

ADVISED BY:

- STEVEN VAN DESSEL**
HEAD ADVISOR
- SOROUGH FARZIN-MOGHADAM**
ARCHITECTURAL ADVISOR
- KENNETH M. ELOVITZ**
MECHANICAL SYSTEMS ADVISOR
- HUSSAM S. SALEEM**
STRUCTURAL ENGINEERING ADVISOR

SHEET NAME:

**FLOOR
FRAMING
PLAN**

SHEET NUMBER:

S1.0

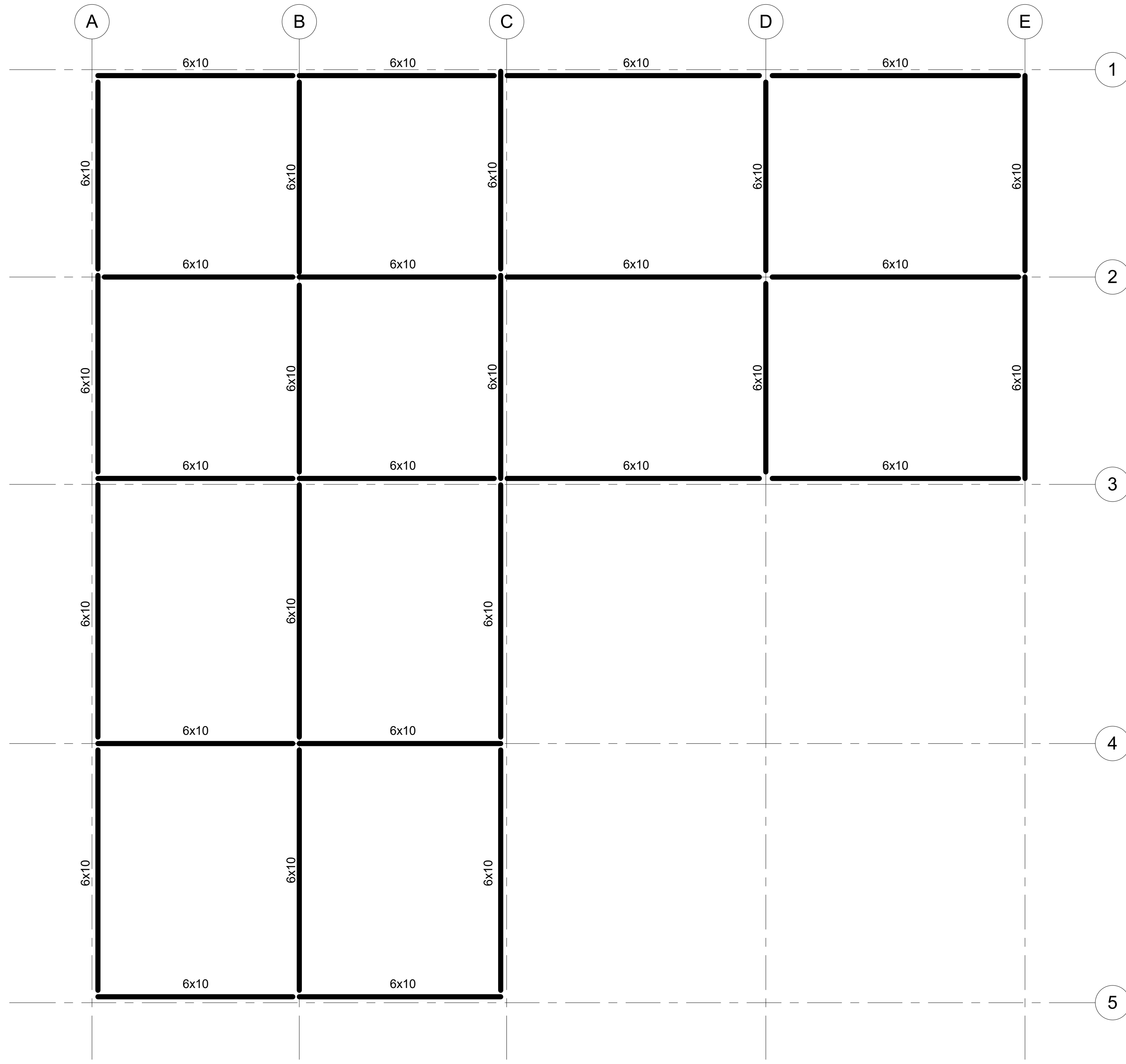

1 FLOOR FRAMING PLAN
3/8" = 1'-0"

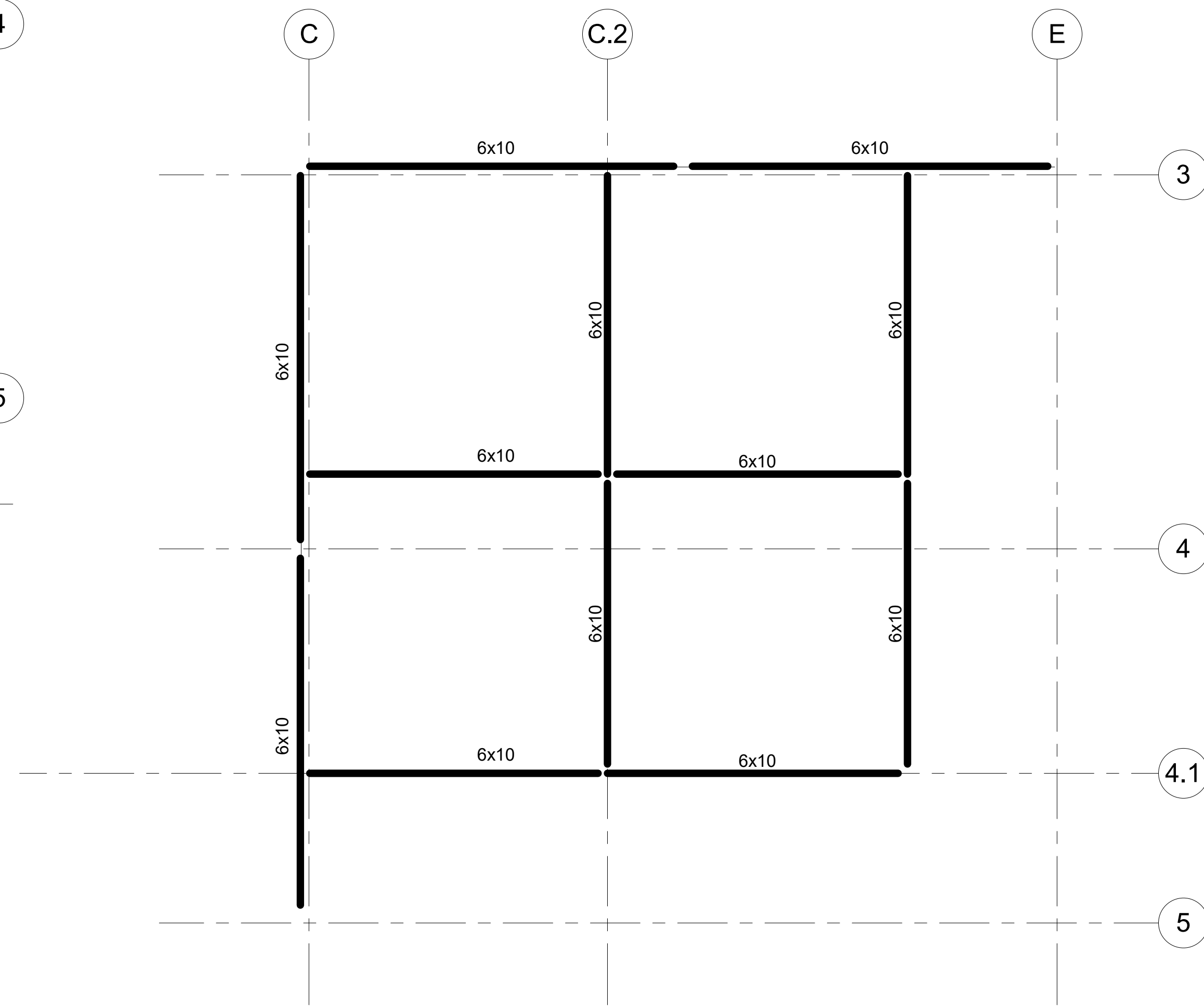

2 DECK FRAMING PLAN
3/8" = 1'-0"