

# **The Synthesis and Improvement of a Force Balanced, Sealed Double Passive Radiator Bass Box for a Low Profile Home Speaker System**

A Major Qualifying Project

Submitted to the Faculty of

WORCESTER POLYTECHNIC INSTITUTE

In partial fulfillment of the requirements for the

Degree of Bachelor of Science

In Mechanical Engineering

Project Number: J2S-J1S-1

Submitted by

**Nicholas Borsari**

**Brett Carbonneau**

**Karim Elsayed**

**Jeremy Honig**

Date Submitted: April 25, 2018

Advisor: Joe Stabile

# Abstract

Working alongside four other mechanical and electrical engineering teams, this Major Qualifying Project aimed to manufacture a low profile, wall-mounted home speaker system. The main goal of our group was to prototype a low profile, force balanced, sealed passive radiator bass box with a low frequency response. By conducting background research in parallel with findings taken from the 2016-2017 MQP, “The Synthesis and Design of a Small Speaker System,” initial designs were prototyped using additive manufacturing. Simulation tools and test equipment were then utilized to iterate and improve bass response of moving magnet transducers to reach an ideal design. Additionally, mechanically rotating speaker housings were designed for moving coil transducers, to assist in sound steering. The overall work completed in this project and the other sub-groups was finally assembled into the low profile wall-mounted home speaker system.

# Acknowledgements

Our Major Qualifying Project team would like to give a special thank you to our advisor Joe Stabile his ever-present support and project expertise during the MQP process. We also want to thank Bose Corporation, specifically Guy Torio, Bill Berardi, Jeff Copeland, Binu Oommen, and Dan Sheehan, for their sponsorship and support of our project.

Additionally, we would like to thank Professor Erica Stults for assisting with 3D printing our prototypes with an Objet 260 Connex, Pierre-Marie Nigay for assisting with Instron testing, professor Nikhil Karanjgaokar for access to the Polytec Scanning Vibrometer, Hrachya Kocharyan for teaching us how to use and assisting us with the Polytec Scanning Vibrometer, and the WPI Machine shop for allowing us to use their laser cutter. We would also like to thank Carlos Osorio for his assistance with using the software program Simscape. Lastly, we would like to thank the other four sub-teams within our collective Major Qualifying Projects for their work and communication throughout the year.

## Contents

<b>The Synthesis and Improvement of a Force Balanced, Sealed Double Passive Radiator Bass Box for a Low Profile Home Speaker System</b> .....	1
<b>Abstract</b> .....	2
<b>Acknowledgements</b> .....	2
<b>List of Figures</b> .....	6
<b>List of Tables</b> .....	9
<b>Executive Summary</b> .....	10
<b>Chapter 1: Introduction</b> .....	12
<b>Chapter 2: Background</b> .....	13
2.1 Overview of Speakers .....	13
2.2 Speaker Enclosures/Boxes .....	14
2.3 Dual Passive Radiator .....	17
2.4 Review of 2016/2017's Major Qualifying Project: <i>The Synthesis and Design of a Small Speaker System</i> .....	20
<b>Chapter 3: Methods</b> .....	23
3.1 Research Objectives.....	23
3.2 Design and Simulation .....	24
3.3 Computer Modeling (PSpice/Simscape) .....	25
3.3.1 Cadence PSpice.....	25
3.3.2 Simscape .....	27
3.4 3D Printing .....	29
3.5 Instron Testing .....	30
3.6 Polytec Scanning Vibrometer Testing .....	31
3.7 Communication with other Sub-teams and Redesigning .....	34
3.8 Low Profile Home Speaker System Frame.....	34
<b>Chapter 4: Results</b> .....	35
4.1 Initial Improvements .....	35
4.2 Computer Modeling.....	38
4.2.1 PSpice.....	38
4.2.2 Simscape .....	40
4.3 Daffodil Transducer Incorporation.....	42
4.3.1 Daffodil Box Design 1 .....	42

4.3.2 Daffodil Box Design 2 .....	50
4.4 Moving Magnet Transducer Incorporation .....	59
4.4.1 Moving Magnet Box Design 1 .....	59
4.5 Moving Coil Transducer Flexible Housing Incorporation .....	75
4.5.1 Moving Coil Flexible Housing Design 1.....	75
4.5.2 Moving Coil Flexible Housing Design 2.....	79
4.6 Overall Low Profile Home Speaker System Design .....	83
4.6.1 Speaker System Design 1 .....	84
4.6.2 Speaker System Design 2 .....	88
<b>Chapter 5: Recommendations</b> .....	91
<b>Chapter 6: Conclusions</b> .....	92
6.1 Limitations of the Project .....	93
<b>References</b> .....	95
<b>Appendices</b> .....	96
Appendix A: Procedure for printing the combo rubber-surround/abs-cone in WPI's Rapid Prototyping Lab .....	96
Appendix B: Procedure for ANSYS simulation of an X weight transducer on a speaker box/passive radiator .....	99
Appendix C: Calibration of the Instron Microtester .....	103
Appendix D: Polytec Vibrometer Scans of Daffodil Box Design 1 version 1 .....	103
Appendix E: Polytec Vibrometer Scans of Daffodil Box Design 1 version 2 .....	106
Appendix F: Polytec Vibrometer Scans of Daffodil Design 2 Version 2.....	110
Appendix G: Polytec Vibrometer Scans of Daffodil Box Design 2 Version 3 .....	113
Appendix H: Polytec Vibrometer Scans of Moving Magnet Box Design 1 Version 4 (Final Design) 117	
Print 1: Moving Magnet Box Design 1 Version 4 .....	118
Print 2: Moving Magnet Box Design 1 Version 4 .....	121
Print 3: Moving Magnet Box Design 1 Version 4 .....	122
Print 4: Moving Magnet Box Design 1 Version 4 .....	125
Print 5: Moving Magnet Box Design 1 Version 4 .....	126
Print 6: Moving Magnet Box Design 1 Version 4 .....	127
Appendix I: How to Use Simscape to Model a Speaker System .....	128
Appendix J: Presentation on How to Use PSpice: Electro-Mechano-Acoustic Modeling .....	133
Appendix K: Final Presentation to Bose Corporation.....	138

Appendix L: Final Poster for Project Presentation Day at Worcester Polytechnic Institute .....	146
Appendix M: PSpice Installation Tutorial .....	147
<b>Authorship</b> .....	149
Nicholas Borsari .....	149
Brett Carbonneau .....	149
Karim Elsayed .....	151
Jeremy Honig .....	151

# List of Figures

Figure 1: Basic components of a speaker [1] .....	13
Figure 2: Closed speaker box [3] .....	15
Figure 3: Infinite baffle [3] .....	15
Figure 4: Ported speaker box [3].....	16
Figure 5: Passive radiator speaker box [3] .....	17
Figure 6: Displacement vs frequency for 3 different speakers [6].....	18
Figure 7: Cross section view of a basic dual passive radiator design [6].....	19
Figure 8: Cross section view of a double passive speaker box design with two transducers [6].....	20
Figure 9: Cross section view of a double passive radiator speaker box design with a raised bottom passive radiator [6] .....	20
Figure 10: Test set up for recreating an iPhone 6 speaker [7].....	21
Figure 11: Passive radiator with a military headset transducer as the mass [7].....	21
Figure 12: Initial prototype of a dual passive radiator [7].....	22
Figure 13: 2016/2017 MQP's final dual passive radiator design [7].....	23
Figure 14: A simple transducer modelled in Cadence PSpice in mobility analogy .....	26
Figure 15: A single passive radiator system [2] .....	26
Figure 16: A simple mass-spring-damper system created with Simscape .....	28
Figure 17: Simscape component representation .....	28
Figure 18: Instron MicroTester used for testing .....	31
Figure 19: Dual passive radiator mount .....	32
Figure 20: 3D printed mount for a penny-wise speaker.....	32
Figure 21: Magnitude vs. frequency graph generated by the Polytec Scanning Vibrometer .....	33
Figure 22: Screenshots of the final bottom passive radiator design generated by the Polytec Scanning Vibrometer .....	33
Figure 23: 2016/2017's final dual passive radiator speaker box [7].....	35
Figure 24: Labeled cross section view of 2016/2017's final dual passive radiator design [7].....	36
Figure 25: Top and bottom half of 2016/2017's final dual passive radiator design [7].....	36
Figure 26: Improved bottom assembly for 2016/2017's final dual passive radiator design .....	37
Figure 27: Display made for Initial Bose Presentation incorporating 2016/2017's designs and initial designs from this project .....	37
Figure 28: Satin2 40mm micro-driver spec-sheet.....	38
Figure 29: PSpice Model and Results for Satin2 40mm Micro-diver .....	39
Figure 30: PSpice model of the single passive radiator system .....	39
Figure 31: PSpice Results for the single passive radiator system.....	39
Figure 32: Final Simscape design of a dual passive radiator speaker box with a moving magnet transducer .....	41
Figure 33: Linear analysis of the final dual passive radiator moving magnet box model .....	42
Figure 34: Daffodil transducer obtained from Bose Corporation.....	42
Figure 35: Daffodil Box Design 1 Version 1 CAD model .....	44
Figure 36: Labeled section view of Daffodil Box Design 1 Version 1 .....	44
Figure 37: Daffodil Box Design 1 Version 1 3D Printed Prototype .....	45
Figure 38: Daffodil Box Design 1 Version 1 Polytec Scanning Vibrometer scans .....	46

Figure 39: Daffodil Box Design 1 Version 1 Polytec Scanning Vibrometer slow motion video screen shots .....	46
Figure 40: Daffodil Box Design 1 Version 2 labeled CAD model .....	48
Figure 41: Daffodil Box Design 1 Version 2 3D printed prototype.....	48
Figure 42: Daffodil Design 1 Version 2 sample Polytec Scanning Vibrometer scan .....	50
Figure 43: Daffodil Box Design 2 Version 1 labeled cross section view .....	51
Figure 44: Daffodil Box Design 2 Version 1 labeled cross section view .....	52
Figure 45: Daffodil Box Design 2 Version 1 3D printed prototype.....	53
Figure 46: Daffodil Box Design 2 Version 2 sample Polytec Scanning Vibrometer Scans .....	54
Figure 47: Daffodil Box Design 2 Version 3 cross section view .....	55
Figure 48: Daffodil Box Design 2 Version 3 3D Printed Prototype .....	55
Figure 49: ANSYS structural simulation of Daffodil Box Design 2 Version 3.....	56
Figure 50: ANSYS harmonic response simulation of Daffodil Box Design 2 Version 3.....	56
Figure 51: Daffodil Box Design 2 Version 3 sample front Polytec Scanning Vibrometer scan.....	58
Figure 52: Daffodil Box Design 2 Version 3 sample back Polytec Scanning Vibrometer scan.....	58
Figure 53: Moving Magnet Box Design 1 Version 1 cross section view .....	60
Figure 54: Moving Magnet Box Design 1 Version 2 CAD model .....	61
Figure 55: Moving Magnet Box Design 1 Version 2 cross section view .....	62
Figure 56: Daffodil Box Design 1 Version 2 with housing.....	63
Figure 57: Daffodil Box Design 1 Version 2 with housing cross section view .....	63
Figure 58: Moving Magnet Box Design 1 Version 3 cross section .....	65
Figure 59: Moving Magnet Box Design 1 Version 3 cross section with housing .....	65
Figure 60: Moving Magnet Box Design 1 Version 3 3D printed prototype.....	66
Figure 61: Moving Magnet Box Design 1 Version 3 modified assembly.....	67
Figure 62: Moving Magnet Final Design 1 Version 4 CAD model.....	69
Figure 63: Moving Magnet Final Design 1 Version 4 cross section view .....	70
Figure 64: Assembly steps of the final Moving Magnet Box Design .....	71
Figure 65: Moving Magnet Box Final Design 1 Version 4 Polytec Scanning Vibrometer scan with resonant frequency at ~85 Hz.....	73
Figure 66: Moving Magnet Box Final Design 1 Version 4 Polytec Scanning Vibrometer scan slow motion video screen shot of bottom passive radiator at 85 Hz .....	74
Figure 67: Moving Magnet Box Final Design 1 Version 4 Polytec Scanning Vibrometer scan slow motion video screen shot of bottom passive radiator at 85 Hz .....	74
Figure 68: Moving Coil Flexible Housing Design 1 CAD model .....	76
Figure 69: Moving Coil Flexible Housing Design 1 cross section .....	76
Figure 70: Moving Coil Flexible Housing Design 3D printed prototype assembly .....	78
Figure 71: Moving Coil Flexible Housing Design 2 Version 1 CAD model .....	79
Figure 72: Moving Coil Flexible Housing Design 2 Version 1 cross section .....	80
Figure 73: Moving Coil Flexible Housing Design 2 Version 2 CAD model .....	81
Figure 74: Moving Coil Flexible Housing Design 2 Version 2 CAD model with moving coil transducer.....	82
Figure 75: Final 3D printed Moving Coil Flexible Housing with motor attached .....	83
Figure 76: Final 3D printed Moving Coil Flexible Housing with motor attached and with moving coil transducer.....	83
Figure 77: Speaker System Design 1 Version 1 CAD mode front .....	85

Figure 78: Speaker System Design 1 Version 1 CAD model back.....	86
Figure 79: Speaker System Design 1 Version 2 CAD model .....	87
Figure 80: Speaker System Design 1 Version 2 cross section .....	88
Figure 81: Low Profile Home Speaker System Final Prototype (front) .....	89
Figure 82: Low Profile Home Speaker System Final Prototype (back) .....	90
Figure 83: Final Low Profile Home Speaker System Prototype .....	93



# List of Tables

Table 1: Material properties of Objet materials used [9] .....	29
Table 2: Daffodil Box Design 1 Version 1 Specifications .....	45
Table 3: Daffodil Box Design 1 Version 2 Specifications .....	49
Table 4: Daffodil Box Design 2 Version 1 Specifications .....	51
Table 5: Daffodil Box Design 2 Version 1 specifications.....	53
Table 6: Daffodil Box Design 2 Version 3 Specifications .....	57
Table 7: Moving Magnet Box Design 1 Version 1 Specifications .....	60
Table 8: Moving Magnet Box Design 1 Version 2 Specifications .....	63
Table 9: Moving Magnet Box Design 1 Version 3 Specifications .....	67
Table 10: Moving Magnet Box Design 1 Version 4 Specifications .....	72
Table 11: Moving Coil Flexible Housing Design 1 Specifications .....	77
Table 12: Moving Coil Flexible Housing Design 2 Version 1 Specifications.....	80
Table 13: Moving Coil Flexible Housing Design 2 Version 2 Specifications.....	82

# Executive Summary

Currently, speaker systems have dominated the consumer market ranging from Bluetooth headsets and ear buds, car audio systems, at-home speakers and commercially used speakers such as those in theaters. Often times however, larger speaker systems produce the best bass whereas smaller speakers sacrifice bass frequency for compactness and transportability. With a void in the market of small, bass producing speaker systems, a Major Qualifying Project (MQP) team was formed in the 2016/2017 academic year to create a prototype of a small speaker that can produce bass frequencies. This year, another team of 17 mechanical and electrical engineers was formed to expand the research behind speaker systems and continue to produce ideations of slim, bass-producing speaker systems. The team was divided into five different sub-teams consisting of four mechanical engineering teams that would research different ideations and one electrical engineering group that would focus on the signal processing aspect of the project. Our team researched further into the 2016-17 MQP project *The Synthesis and Design of a Small Speaker System*.

After researching the basics of speakers, different types of speaker enclosures/boxes, and passive radiators, a goal and several objectives were formed. The overall goal of this project was to design and improve a force balanced, sealed double passive radiator bass box that could be incorporated in the low profile home speaker system. This was done by expanding upon our research and designing a variety of speaker box models with SolidWorks. The models were analyzed with ANSYS to ensure ideal structural and material properties. The best models were then prototyped using an Objet Connex 260 3D printer which could print both flexible and rigid materials simultaneously. Once the prototypes were assembled they were then tested with a Polytec Scanning Vibrometer in order to determine the resonant frequencies, which are the frequencies with highest amplitude, and the structural integrity of the designs. They were also tested with an Instron MicroTester in order to verify material properties. Simultaneously to the designing and prototyping processes, a mass-spring-damper simulation model was created with Simscape

by MathWorks. This was done in order to be able to simulate each box design in order to analyze how the box prototypes should perform.

Once final designs were reached, the transducers designed by the other sub-teams were incorporated into our boxes and housings. The speakers were the integrated with the rest of the low profile home speaker system with the help of all five sub-teams. The final projects and designs were then presented to Worcester Polytechnic Institute faculty, students, and alumni and to Bose Corporation.

# Chapter 1: Introduction

Currently, speaker systems have dominated the consumer market ranging from Bluetooth headsets and ear buds, car audio systems, at-home speakers and commercially used speakers such as those in theaters. Often times however, larger speaker systems produce the best bass whereas smaller speakers sacrifice bass frequency for compactness and transportability. With a void in the market of small, bass producing speaker systems, a Major Qualifying Project (MQP) team was formed in the 2016/2017 academic year to create a prototype of a small speaker that can produce bass frequencies.

In the 2017/2018 academic year, another team of 17 mechanical and electrical engineers was formed to expand their research behind speaker systems and continue to produce ideations of low-profile, enhanced bass-producing speaker systems. The team was divided into five different sub-teams. One team would focus on creating a slim, moving coil transducer designed to produce higher frequencies. One team would focus on creating a moving magnet transducer designed to produce low to mid-range frequencies. One team would focus on creating a resonant panel designed to produce the low bass frequencies. The electrical engineer team would focus on signal processing, sound steering, and electrical configuration of the overall system. Lastly, our mechanical engineer team would focus on creating enclosures/boxes to improve low to mid-range frequency response of the moving magnet transducers. Once all the teams had final designs, all of the speakers and hardware would be combined to create a low profile, home speaker system.

# Chapter 2: Background

## 2.1 Overview of Speakers

As noted on Center Point Audio's website, sound usually refers to frequencies between 20Hz-20,000Hz, or the range that humans can hear [1]. When an object moves or vibrates, the kinetic energy released causes a fluctuation in air pressure and results in what humans hear as sound. A transducer converts electrical signals into acoustical energy by moving back and forth to create pressure fluctuations. Different transducer components aid in generating different frequencies.

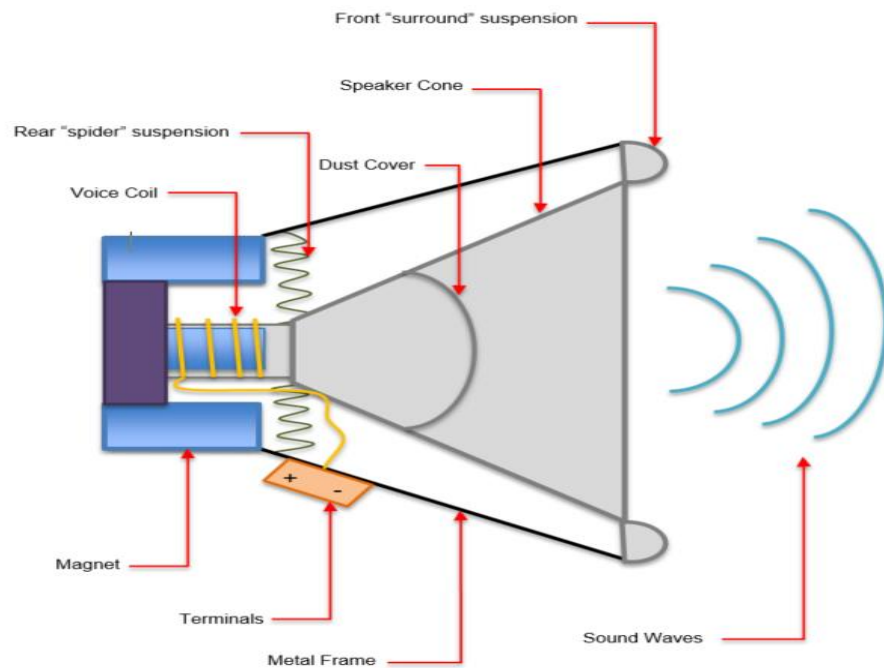

Figure 1: Basic components of a speaker [1]

Figure 1 displays what a basic transducer is comprised of. The cone acts as the moving mass in the system by moving air. While the transducer is in motion, the spider and surround suspension act as a spring, helping to keep the voice coil aligned and to pull the cone back into place after moving forward. The magnet supplies the voice coil with a magnetic field that enables it to move and subsequently move the cone. Once an electrical signal is sent to the voice coil, an alternating magnetic field is generated which in turn, repels from the magnetic field from the magnet. These transducers can emit sound waves

not only detectable by the human ear but also infra-sound (very low frequencies) and ultrasound (very high frequencies).

When a transducer is used in a larger stereo system, the system is often called a loudspeaker. To get a better understanding of a loudspeaker we must look at the components. All loudspeakers have a source. The source is a device, usually an electronic amplifier, which supplies power in the form of electrical energy. This electrical energy is sent to a driver, which is a transducer mechanism used to convert the electrical energy into mechanical energy. This driver is supported by a baffle, which is used to reduce or prevent radiation from the front of the driver diaphragm. These systems will be housed in an enclosure or “box”. This enclosure is used to allow sound to resonate, as well as preventing sound from the back side of the speaker to mix with sound from the front, creating distortion. The combination of a source, driver, baffle and speaker box form a direct-radiator loudspeaker system. For this loudspeaker to produce non directional sound, that is even sound in any direction, the sound wavelengths must be longer than the driver diaphragm diameter. This range of frequencies is called the piston range [2].

## 2.2 Speaker Enclosures/Boxes

Many types of enclosures/boxes exist for enhancing/adjusting frequency response from transducers. Some of the most common include the closed box, the infinite baffle, the ported box (bass reflex), and the passive radiator box [3]. The closed box is the most simple where it has a closed box and the driver. Absorptive losses in this design are caused by the damping material inside the speaker cabinet [3]. Figure 2 shows an outline of a closed speaker box.

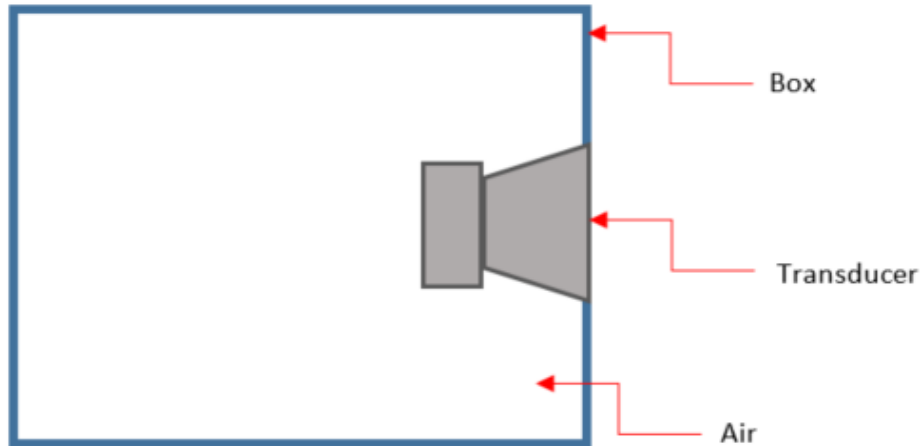

Figure 2: Closed speaker box [3]

Infinite baffle enclosures is a type of sealed box where the enclosure's volume is increased to infinity [3]. While this is impossible to build, it is sufficient to approximate. Figure 3 shows an outline of the infinite baffle.

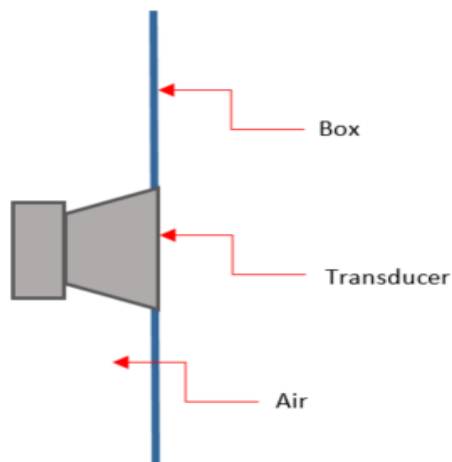
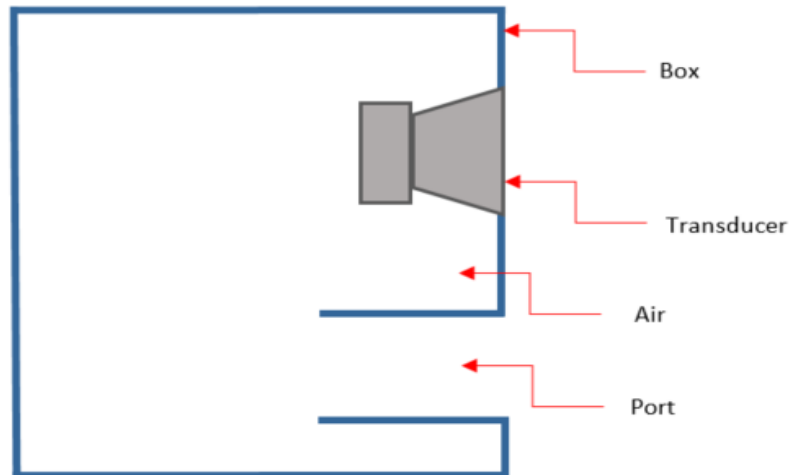

Figure 3: Infinite baffle [3]

Ported box/bass reflex enclosures is a type of Helmholtz resonator (or a container of gas [air] with an open port) that becomes excited by the driver [3]. A simple example of this is blowing across the top neck of an empty bottle and creating a low sound output. The power capacity of such boxes is directly related to the volume of air that is displaced by the system driver, the transducer [4]. Additionally, in order to prevent noise generation and excessive losses, the port area needs to be large enough to

accommodate the volume displaced by the driver [4]. While this design does enhance the low frequency output, it also has some negative effects including poor transient response and extraneous noises stemming from the air flowing at the high output levels [3]. Figure 4 shows an outline of the ported box.



*Figure 4: Ported speaker box [3]*

Finally, the passive radiator box is a close relative to the ported-box system as it is capable of providing a similar low frequency performance. Instead of the open air tube, a diaphragm with a mass encloses the box. This diaphragm with the mass represent the passive radiator and it may be of any desired area, but it is preferable to that the diaphragm to have high compliance, which is the reciprocal of stiffness [2]. This prevents some of the negative effects of ported box including the extraneous noises at higher frequencies [3]. The passive radiator box is able to provide very low tuning frequencies provided there is enough volume [3]. Additionally, using the passive radiator system is of particular importance in compact systems where large air volume is difficult to realize [5]. Figure 5 shows an outline of a passive radiator box.



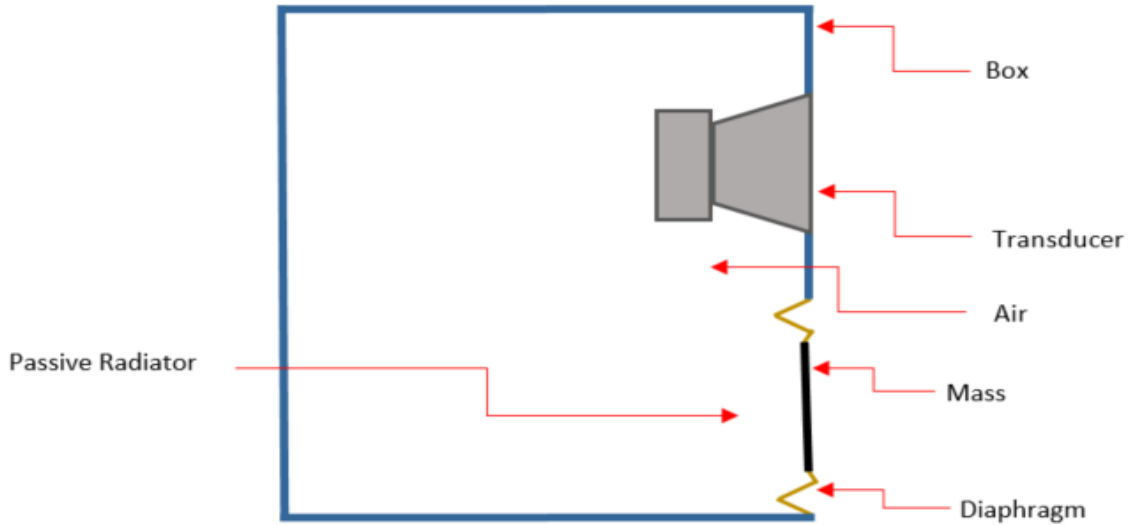

Figure 5: Passive radiator speaker box [3]

## 2.3 Dual Passive Radiator

A passive radiator is a device used commonly in speaker systems to create better bass frequencies. Similar to a transducer, a passive radiator has a diaphragm and cone, but has no voice coil or magnet. According to US patent number 20150281844 A1 (invented and submitted by our project advisor Joe Stabile under Bose Corporation), multiple passive radiators can be incorporated into a speaker to increase bass frequencies [6].

This design involves mounting the main driver of the speaker onto one of the passive radiators. By adding the transducer to the passive radiator and keeping the effective areas of both passive radiators the same, the passive radiator without the driver will vibrate more than the “loaded” passive radiator, but will cause the entire speaker to become force balanced [6]. This causes the passive radiator without the driver to have more of an effect on the acoustics than the other, which allows the speaker to output a wider range of frequencies and less vibrations. The lack of vibrations is caused by the lower moment of inertia due to the lower mass of the passive radiator without the driver, which causes the rocking frequency to be much higher than any frequency the speaker could reach. Figure 6 exemplifies this to be true. This figure is a graph of displacement vs frequency for three different speakers. Line 81 represents a lightly loaded passive radiator, while line 83 shows a heavily loaded passive radiator [6]. In this graph,

the heavily loaded passive radiator is roughly six times the mass of the light passive radiator. Line 83 has a noticeably lower displacement than line 81, proving the concept that a heavily loaded passive radiator will have a lesser effect on frequency range than a lighter passive radiator [6]. Although the heavier passive radiator will have less displacement than the lighter one, both resonant frequencies stay the same at 75Hz.

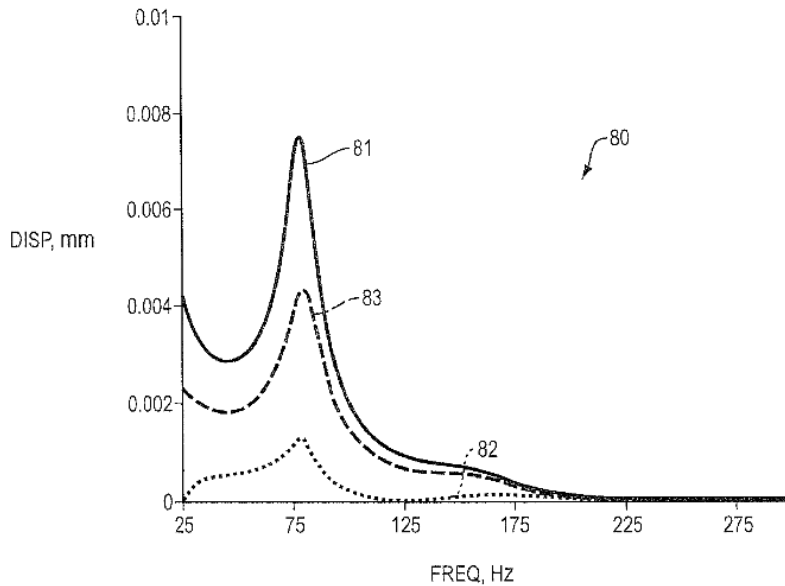

Figure 6: Displacement vs frequency for 3 different speakers [6]

To determine the effective area of a passive radiator one must first mount the passive radiator structure to a closed volume, then move the passive radiator structure in and out, while detecting pressure changes in the closed volume. In this case since both passive radiators are mounted to the same enclosure they will experience the same pressure [6]. This is a crucial aspect of the patent. Since force is equal to area multiplied by pressure, and the pressures are the same, matching the areas of the passive radiators results in a force balanced speaker system.

Figure 7 shows the cross section of the basic dual passive radiator design. In this figure, 22 is the first passive radiator moving along vibration axis 18 in the direction of arrow 13. 22b is the interior surface of the radiator, while 22a is the exterior surface. 32 is the second passive radiator, and is considered the “loaded” passive radiator as speaker 40 sits upon it. Passive radiator 32 moves along

vibration axis 18 as well, in the direction of arrow 53. 24 and 34 are suspension elements that allow for the radiators to linearly vibrate on the axis of vibration. 46 is a stiff suspension element that restricts the speaker from moving itself along the vibration axis, but instead makes the entire passive radiator 32 move. This design is new, as previous designs had the two passive radiators equal in mass. These designs are heavy and large, while this new design is much smaller and able to have less acoustic volume than needed before.

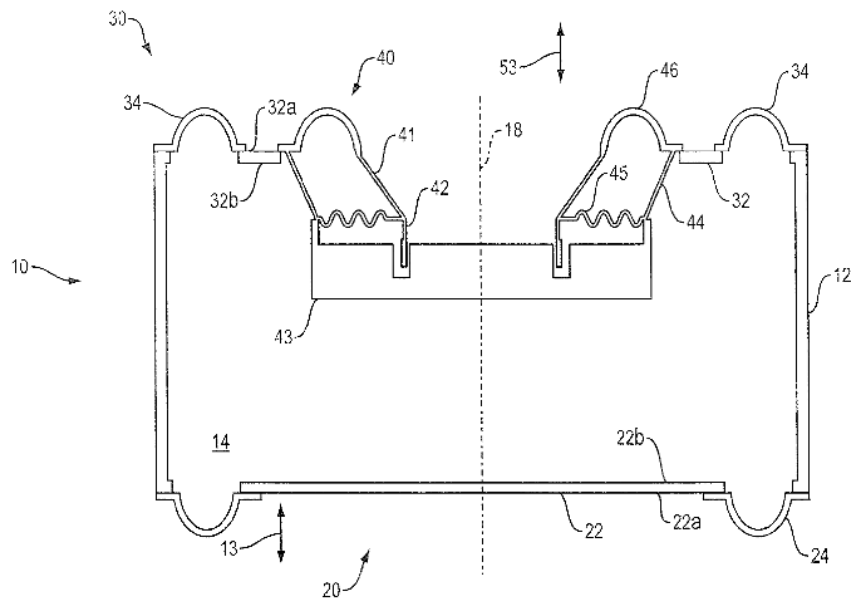

Figure 7: Cross section view of a basic dual passive radiator design [6]

Another feature of patent US 20150281844 A1 “Acoustic Device with Passive Radiators” is the possibility of mounting two speakers simultaneously onto the second passive radiator. To achieve this, the two speakers should be working at the same frequency and in phase, while having their center mass be collinear to the axis of vibration of the passive radiator which they are mounted on [6]. This axis of vibration must also coincide with the center of gravity of the second passive radiator. If these conditions are met, the principles described above will be the same. Figure 8 shows the cross section of this setup. The two passive radiators may have varying shapes if they both move in opposition to each other and have the same effective area. This is efficient, as it allows speaker’s to be very thin. As long as the

passive radiators have the same area, locations can also be varied. Figure 9 shows a possible setup in which the two passive radiators are almost co-planar to each other, allowing for minimal thickness.

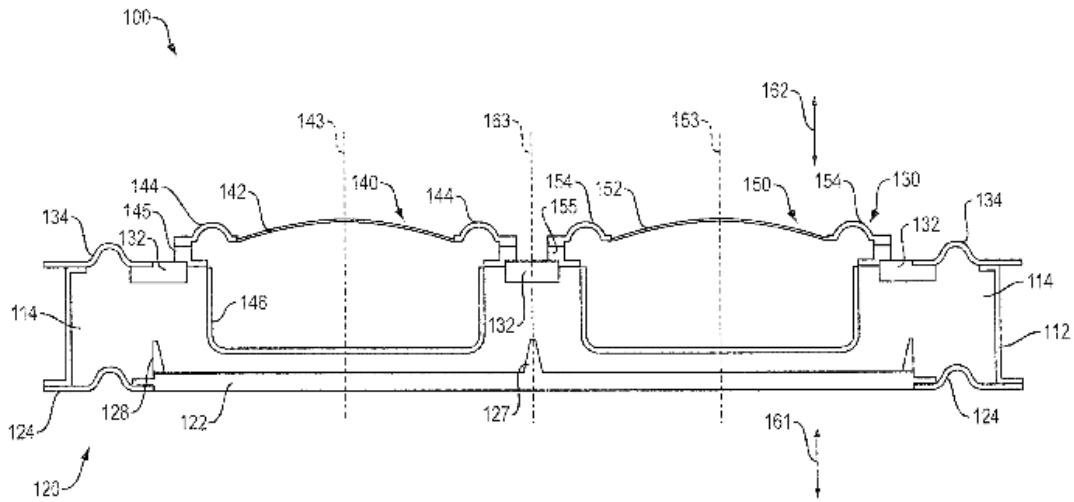

Figure 8: Cross section view of a double passive speaker box design with two transducers [6]

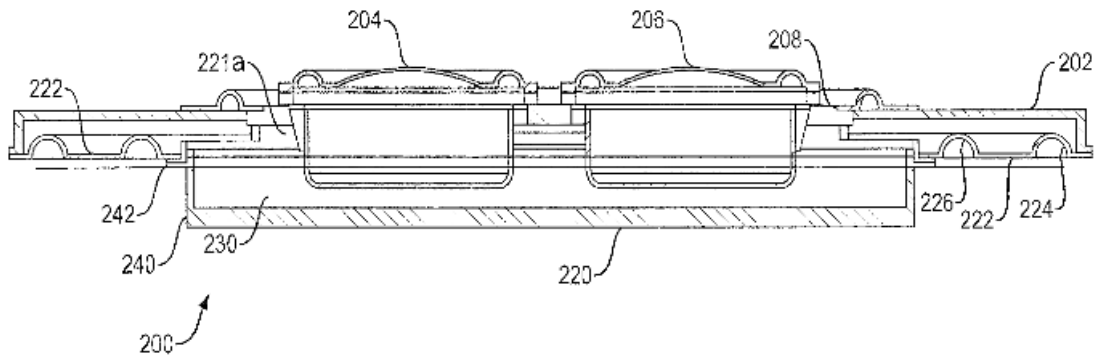

Figure 9: Cross section view of a double passive radiator speaker box design with a raised bottom passive radiator [6]

## 2.4 Review of 2016/2017's Major Qualifying Project: *The Synthesis and Design of a Small Speaker System*

The objective of *The Synthesis and Design of a Small Speaker System* was to implement two passive radiators into one speaker system that would be light and thin in design. In order to minimize the size of the system, the team stacked passive radiators on the front and back of the prototyped box. The team's initial efforts aimed at researching speaker designs and passive radiators and at prototyping to gain

experience with the various 3D printers. The team focused on creating a passive radiator for an iPhone 6 speaker for their first design. Figure 10 shows their test set up for this design.



Figure 10: Test set up for recreating an iPhone 6 speaker [7]

For their second design, the team used a penny as the mass for the rear passive radiator so that the speaker surround could vibrate better which would allow for better quality sound. Many iterations of this design were made with the main purpose of coming up with a design that would use the speaker itself as the mass for one of the passive radiators. Figure 11 shows one of their designs using a military headset speaker as the mass for the passive radiator.

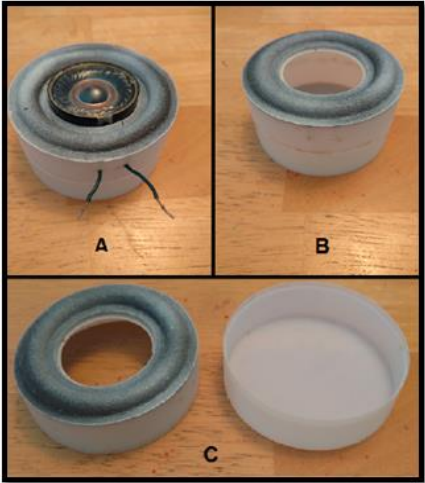

Figure 11: Passive radiator with a military headset transducer as the mass [7]

In their third design a dual passive radiator system was explored. The areas of the passive radiators were designed to be the same so that the prototype would be force balanced (where  $Force = Area \times Pressure$ , with the internal pressure being the same for the front and rear passive radiators). Figure 12 shows one of their prototypes for this design.



Figure 12: Initial prototype of a dual passive radiator [7]

Their final design incorporated the concepts the team had learned from creating many iterations of prototypes. The design featured a front and rear passive radiator, with the speaker as the mass for the front passive radiator and a “racetrack” (a circular ring) as the mass for the rear passive radiator. Figure 13 shows their final dual passive radiator design [7]. The project described in the following sections is an improvement and expansion of this.

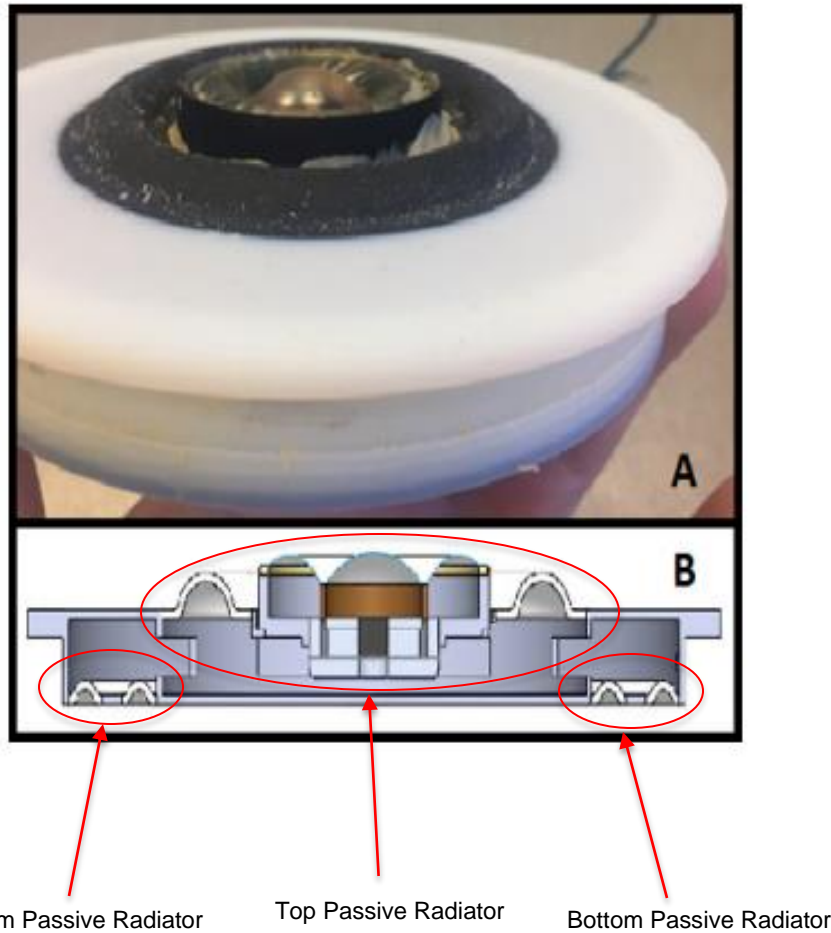

Figure 13: 2016/2017 MQP's final dual passive radiator design [7]

## Chapter 3: Methods

The goal of this project was to design and improve a force balanced, sealed double passive radiator bass box for a low profile home speaker system. The bass box would incorporate a moving magnet transducer designed by one of the other sub-teams. The bass box would be designated to produce frequencies from about 80 to 200 Hz in the final low profile home speaker system.

### 3.1 Research Objectives

1. Research thin speaker technology and develop an understanding of how speakers work and what direction the technology is heading in.

2. Study 2016/2017 “Synthesis and design of a small speaker system” MQP’s prototype speakers and improve upon their designs.
3. Based on our previous research design and fabricate a speaker box that is capable of producing low to mid-range bass and good sound quality.
4. Model speaker systems to predict performance and to make parameter adjustment decisions.
5. Collaborate with the other groups that are designing transducers and create speaker box designs for each that improve upon our previous designs.
6. Design a speaker system frame that incorporates the other team’s transducers, our box designs, and sound steering technology.
7. Come together collectively (all 5 sub-teams) as an MQP group and develop a final product, a low profile home speaker system.

## 3.2 Design and Simulation

In order to design each speaker box SOLIDWORKS® was utilized so that designs could easily be incorporated with the other sub-team’s transducer designs. Additionally, it was the Computer Aided Design (CAD) program that the team was the most familiar with. In order to prototype the best design, each team member created a design. Once there were multiple different designs, the team collaborated and combined the best features of each design in order to merge the designs into two prototypes. After the designs were finished, they were imported into ANSYS in order to simulate the operation after incorporating a transducer into the speaker box. ANSYS was chosen as the simulation software because it was relatively easy to learn and the SolidWorks models could be directly imported into the program. ANSYS was very helpful in determining the desired thickness and properties of the flexible surrounds that were incorporated into our box designs. Since multiple different transducers were designed and used in the speaker boxes, the top surround had to both support the weight of the transducer and be flexible enough to vibrate and create a specific frequency. A brief ANSYS tutorial is described in Appendix B.



### 3.3 Computer Modeling (PSpice/Simscape)

Speaker systems can be designed to meet specific requirements, or to reach optimal performance. The designing process requires knowledge of speaker system components, how they perform, and their integration. The ability to predict how certain design-parameters affect the acoustic behavior is seen to of great value. It saves time, cost, and effort of prototyping and testing. As a result, multiple software programs, Cadence PSpice and Simscape toolbox in MATLAB, were investigated and used in acoustic modeling. This helped us to predict the acoustic behavior of our speaker system and to design our speaker box accordingly.

#### 3.3.1 Cadence PSpice

Lumped parameter modeling is used to approximate the physical behavior of the speaker system. Cadence PSpice software, which is an electronic design software that is commercially free, allowed us to represent the mechanical system in the electric domain [8]. The modeling is called electro-mechano-acoustic modeling and it enables us to predict the systems acoustic behavior. Figure 14 shows a simple transducer modelled in Cadence PSpice in mobility analogy, which is one of two main analogies to represent a mechanical system in the electric domain. The voltage,  $V_2$ , corresponds to a power source to drive the transducer.  $R_1$  and  $L_1$  are the coil resistance and coil inductance, respectively. Three components,  $C_1$ ,  $L_2$ , and  $R_2$ , are shown in parallel and they represent the mass, compliance, and dissipative elements of the transducer, respectively [8].

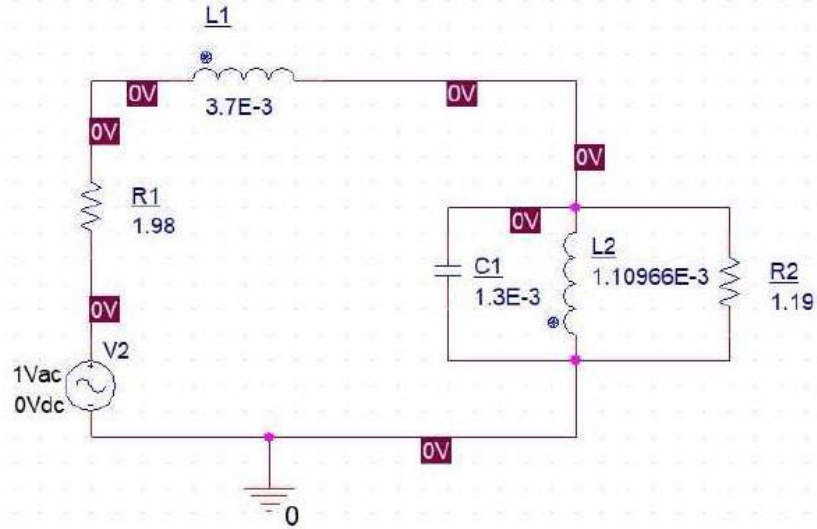

Figure 14: A simple transducer modelled in Cadence PSpice in mobility analogy

Additionally, further studies on passive radiators show how to accurately a single passive radiator system in the electrical domain. In Figure 15, Richard H. Small shows the model for a single passive radiator system and its important parameters.

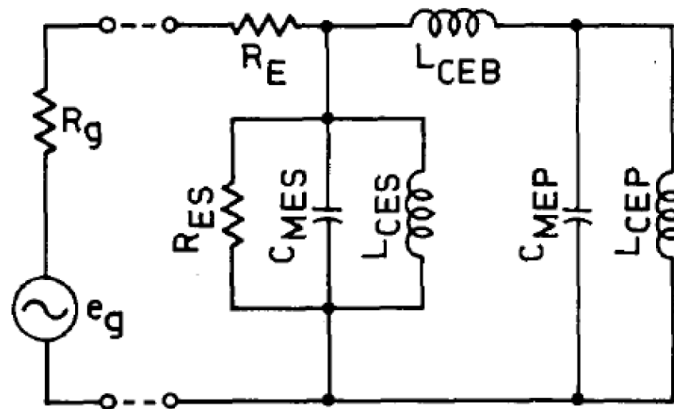

Figure 15: A single passive radiator system [2]

The important parameters in this system are:

- $R_g$  and  $R_E$  which are the resistances of the coil
- $R_{ES}$  which is the resistance of the speaker
- $C_{MES}$  which is the capacitance representing the speaker's mass
- $L_{MES}$  which is the inductance representing the speaker's compliance
- $C_{MEP}$  which is the capacitance representing the passive-radiator's mass
- $L_{MEP}$  which is the inductance representing the passive-radiator's compliance

In order to gain more background knowledge on how a mechanical system and its components are translated into the electrical domain using mobility analogy, refer to Appendix J and Appendix M.

### 3.3.2 Simscape

Simulink is a software program within MathWork's software program MATLAB that enables the user to design a system in a simulation environment. Simscape itself is a software program that operates within Simulink. Simscape enables users to model physical networks while incorporating different types of systems including electrical, gas, hydraulic, magnetic, mechanical, physical signals, thermal, thermal liquid, and two-phase fluid. One feature of these tools enables users to obtain a projected peak frequency response for a closed volume system. In order to become acquainted with the software, tutorials, instructional reports and phone conversations with an employee of MathWorks occurred.

In order to obtain a model that would produce an accurate peak frequency response prediction, basic models of a speaker system needed to be made. The first model created was a simple, mass-spring-damper system, seen in Figure 16. Since the speaker and the passive radiators each have a mass, compliance and mechanical losses, a mass-spring-damper system can be used to symbolize each respective component. The spring represents the compliance and the damper represents the mechanical losses. In the model, the Ideal Force Source acts as a means of applying motion to the system. The Ideal Translational Motion Sensor converts the translational motion into velocity and position data that can be viewed and analyzed. In addition to a mass-spring-damper, each component incorporated an air spring as well, since both the speaker and the passive radiators act on air and vice versa. The air spring can be seen on the left side of Figure 17. The right side of the figure also explains what each component in the model represents. In order for the model to function, a signal is required. The chirp signal seen in Figure 16 is connected to a "Simulink-PS Converter" which converts a Simulink input signal into a physical signal output. The "PS-Simulink Converter" acts the opposite way, converting a physical signal input into a Simulink signal output. The ground, or "Mechanical Translational Reference," is used to physically affix

a component to the frame of the speaker system. The “Solver Configuration” is required in order to analyze the system.

To gain more background knowledge on the Simscape modeling process, see Appendix I.

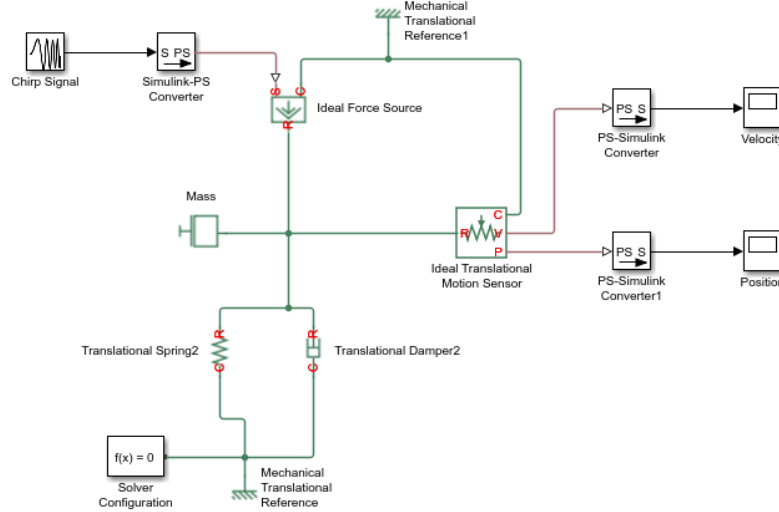

Figure 16: A simple mass-spring-damper system created with Simscape

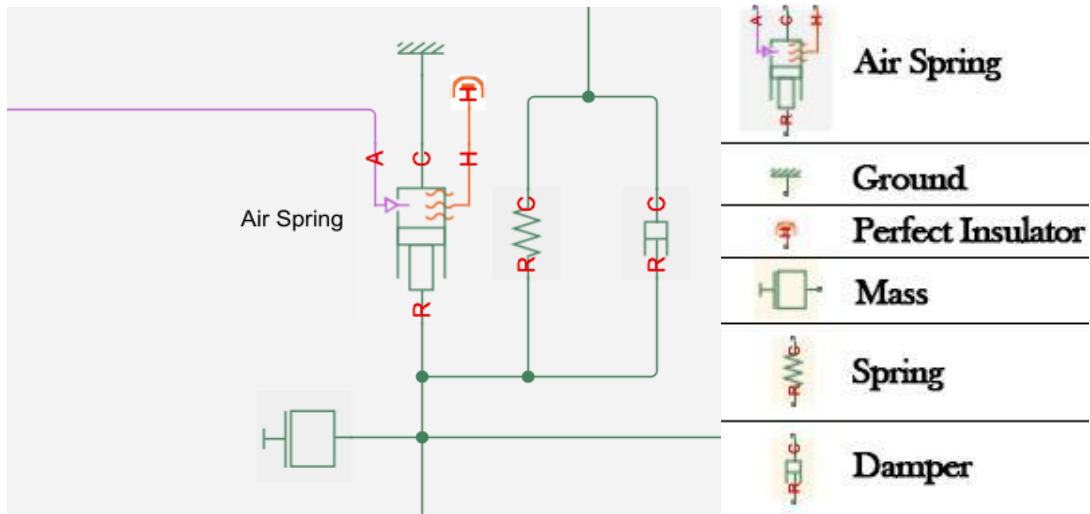

Figure 17: Simscape component representation

### 3.4 3D Printing

Once the speaker box/frame designs’ dimensions were final and the simulations and computer models were up to date, the speaker box prototypes were 3d printed using the Objet 260 Connex in WPI’s rapid prototyping design facility. Most of the speaker box prototypes were printed with two parts (the top assembly and bottom assembly). The advantage of using this printer was that it could print both flexible and rigid materials on the same prototype. This allowed for the flexible surrounds to be printed and already attached to the rigid box. The only assembly required after the prototypes were printed was to secure the top and bottom assemblies together (with silicone) and to secure the transducer to the top assembly’s surround (also done with silicone). Silicone was used because it was easy to apply, created a secure seal so that the box is air-sealed, and because it was easily removable. Additionally, since the rapid prototyping design facility was operated by the Academic Resources Center (ARC) at WPI, our team would send the STL files of our SolidWorks designs to the rapid prototyping lab and specify the materials that each part was to be printed from. For all of the speaker box prototypes, VeroClear or VeroWhite was used to print the rigid parts, and TengaBlackPlus was used to print the flexible parts. The thickness of the TengaBlackPlus was adjusted in order to adjust the stiffness of the surrounds depending on the transducer being used. The printing time varied for each of our prototypes but generally took 2-3 days for the prototypes to finish printing. See Table 1 for material properties [9].The printers build size was 255 x 252 x 200 mm (10.0 x 9.9 x 7.9 in.) [9]. A brief 3D printing submission tutorial is shown in Appendix A.

*Table 1: Material properties of Objet materials used [9]*

<b><u>Material</u></b>	<b><u>VeroClear/VeroWhite</u></b>	<b><u>TengaBlackPlus</u></b>
<b><u>Color</u></b>	Clear/White	Black
<b><u>Modulus of Elasticity</u></b>	2000-3000 MPa	-
<b><u>Flexural Strength</u></b>	75-110 MPa	-

<b><u>Flexural Modulus</u></b>	2200-3200 MPa	-
<b><u>Tensile Strength</u></b>	50-65 MPa	0.8-1.5 MPa
<b><u>HDT, C @ 0.45MPa</u></b>	45-50 C	-
<b><u>HDT, C @ 1.82MPa</u></b>	45-50 C	-
<b><u>Izod Notched Impact</u></b>	20-30 J/M	-
<b><u>Water Absorption</u></b>	1.1-1.5%	-
<b><u>Tg</u></b>	52-54 C	-
<b><u>Elongation at Break</u></b>	-	170-220%
<b><u>Compressive Set</u></b>	-	4-5%
<b><u>Shore Hardness (A)</u></b>	-	26-28
<b><u>Shore Hardness (D)</u></b>	83-86	-
<b><u>Rockwell Hardness (M)</u></b>	73-76	-
<b><u>Tensile Tear Resistance</u></b>	-	2-4 Kg/cm
<b><u>Polymerized Density</u></b>	1.18-1.19 g/cm <sup>3</sup>	1.12-1.13 g/cm <sup>3</sup>
<b><u>Ash content</u></b>	0.02-0.06%	-

### 3.5 Instron Testing

To properly determine the numerical values for compliance needed in our PSpice and Simscape models, an Instron MicroTester was used for testing. The Instron performs many different tests, however to determine compliance, our group used a 3-point bending test in which deflection was recorded versus force. The prototypes were placed on a flat stand in the Instron machine, while a small probe slowly depressed. This is shown in Figure 18.

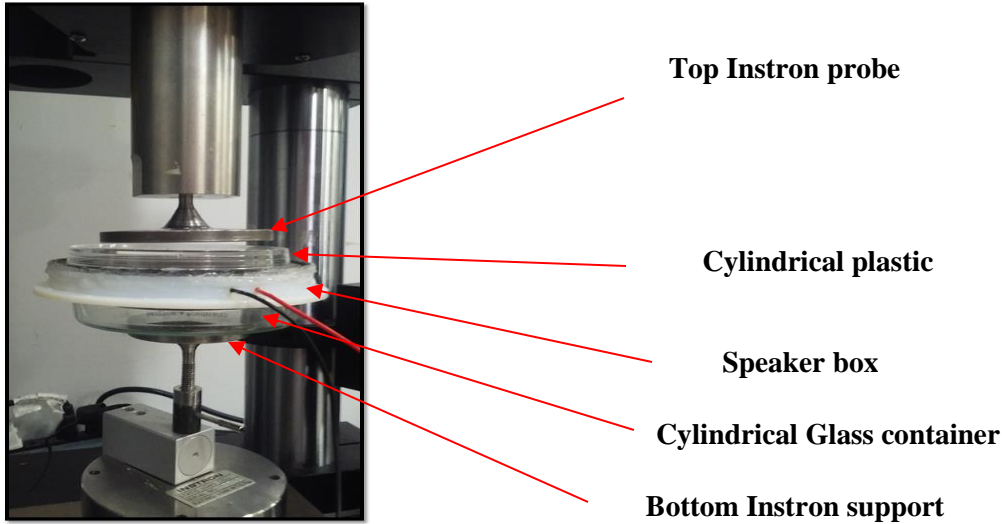

*Figure 18: Instron MicroTester used for testing*

To determine the compliance of the passive radiators, first the speaker box assembly needed to be taken apart. Next, the half that needed to be tested would be placed on the Instron. To only apply force onto the “racetrack” of the passive radiator, a small plastic container would be used. This container had a radius that when placed face down on the racetrack, lied in the center. This allowed for the probe to be placed on the glass container, which in turn applied an evenly distributed load around the entire racetrack. The Instron machine would apply small increments of force from a range we chose. Often this range was zero to three Newtons. As the probe placed the load onto the container, deflection of the part was recorded. Since mechanical stiffness is force over displacement the data recorded by the Instron allowed us to determine the stiffness of the material in question. Knowing that compliance is the inverse of stiffness, we used this data to determine compliance of different materials such as the TangoBlackPlus and the Daffodil transducer. Then we added this data to the PSpice and ANSYS models to determine the behavior of the material at different frequencies and loads.

### 3.6 Polytec Scanning Vibrometer Testing

Once the speaker box was 3d printed, the Instron testing was completed, and the transducer was secured airtight to the box, the speaker assembly could be tested using WPI’s Polytec Scanning

Vibrometer. This machine used laser sensors to sense the vibrations of the speaker and passive radiator prototypes at specific frequencies, voltage, and sound signals. It is able to use the Doppler Effect in order to take non-contact vibration measurements. It can then convert these measurements to graphs and slow motion videos for analysis.

For this process to work the speaker needed to be fixed in the vertical direction so that the lasers from the Vibrometer could sense the vibrations in the areas that were of interest. This requires a mount to hold the speaker in a fixed position on the lab bench. Our team improved upon 2016 MQP's mount designs, shown in Figure 19 and Figure 20.



*Figure 19: Dual passive radiator mount for 2016/2017's improved final design*



*Figure 20: 3D printed mount for a penny-wise speaker*

However, since our team expected to design prototypes with different dimensions, it was determined to take use of clamps to fix the prototype to the lab bench. These clamps allowed for a variety of diameters and worked just as well, if not better, than the mount that our team improved.

For each of the speaker box prototypes dots of white-out were place at certain locations in order for more accurate laser scanning. Then a resonant frequency was determined using a chirp signal sent from the Scanning Vibrometer software. The resonant frequency was determined from the generated graph as shown in Figure 21.



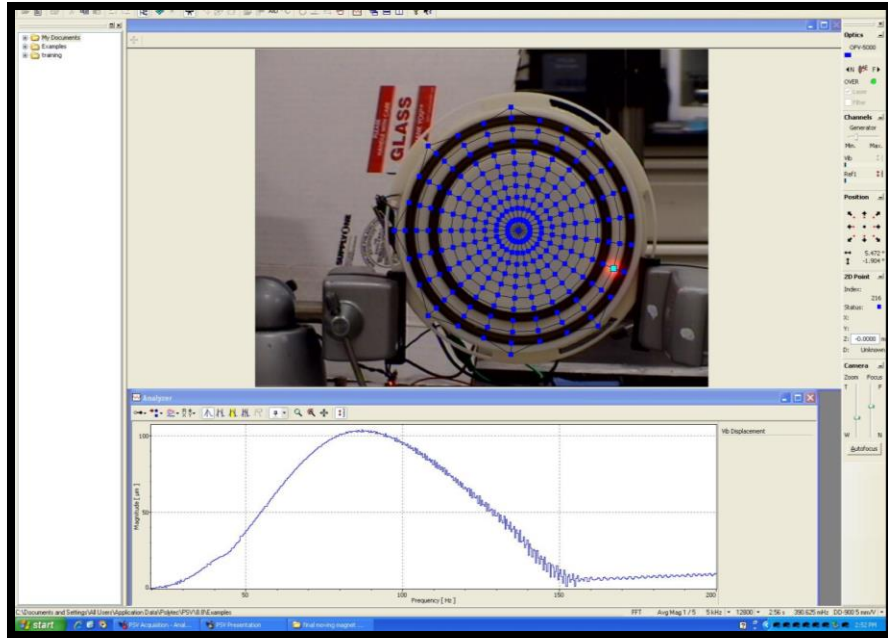

Figure 21: Magnitude vs. frequency graph generated by the Polytec Scanning Vibrometer

The speaker was then operated with this frequency and slow motion videos were generated showing the vibration map. An example is shown in Figure 22. Ideally the rigid parts of the speaker box shouldn't vibrate while the vibration of the passive radiators should show even vibration distribution. If this wasn't the case our team would reassess the design and develop improvements on the next prototype.

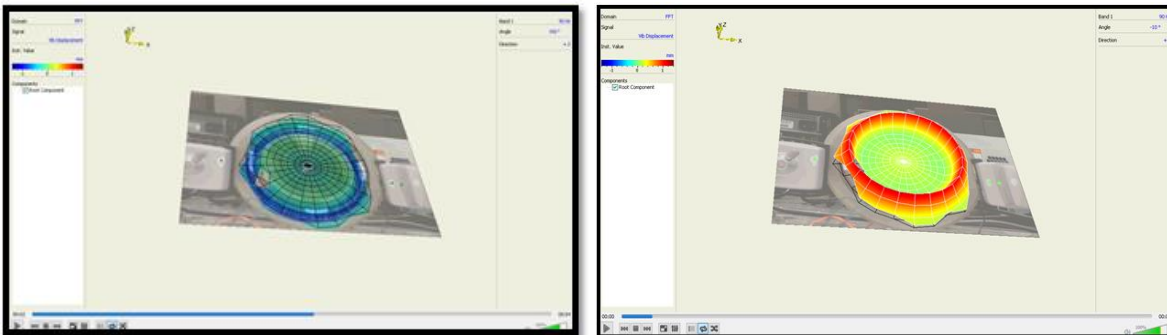

Figure 22: Screenshots of the final bottom passive radiator design generated by the Polytec Scanning Vibrometer

### 3.7 Communication with other Sub-teams and Redesigning

The final product of this MQP, was a low profile speaker system, incorporating the work of the five different sub-teams. These sub-teams all have the main goal in mind during their individual work, and therefore it is necessary for each group to stay in contact with each other. Our sub-team's main focus was to develop a speaker box to house an ultra-thin, moving magnet transducer, developed by another sub-team. With this in mind, it is very important that our group stays in contact with each transducer design group. By staying in contact with the moving magnet sub-team, our sub-team was able to create a speaker box design that could easily houses their new ultra-thin speaker designs. Staying in contact with their sub-team allowed for us to give and receive advice on ways to easily incorporate their design without having to drastically change our own design. Contact with the moving coil, resonant exciter, and the electrical group has allowed us to easily brainstorm and design prototypes for the final speaker system. Understanding what each group has been working on and designing gave a good understanding of different elements needed to incorporate into our final design. Additionally, weekly meetings between all sub-teams assisted with ensuring that everyone was communicating.

### 3.8 Low Profile Home Speaker System Frame

As the development process progressed, a frame that incorporated the hardware designed by all of the sub-teams was needed. This frame would serve to combine all of the transducer designs, the speaker box designs, the sensing technology, and the sound steering technology.

# Chapter 4: Results

## 4.1 Initial Improvements

Our team first analyzed the speaker boxes that the 2016/2017 MQP created in order to improve upon their design and incorporate various transducers. Shown in Figure 23 is the final model from the 2016 MQP. Figure 24 has the different parts labeled and can be referred to for the later designs. In this model the flexible material (TengoBlackPlus) is white and the rigid material (VeroWhite) is gray. In Figure 24 the bottom outer surround, the bottom inner surround, and the racetrack all make up the bottom passive radiator. Similarly, the top surround and the transducer both make up the top passive radiator. Figure 25 shows the top and bottom halves of the speaker box design.

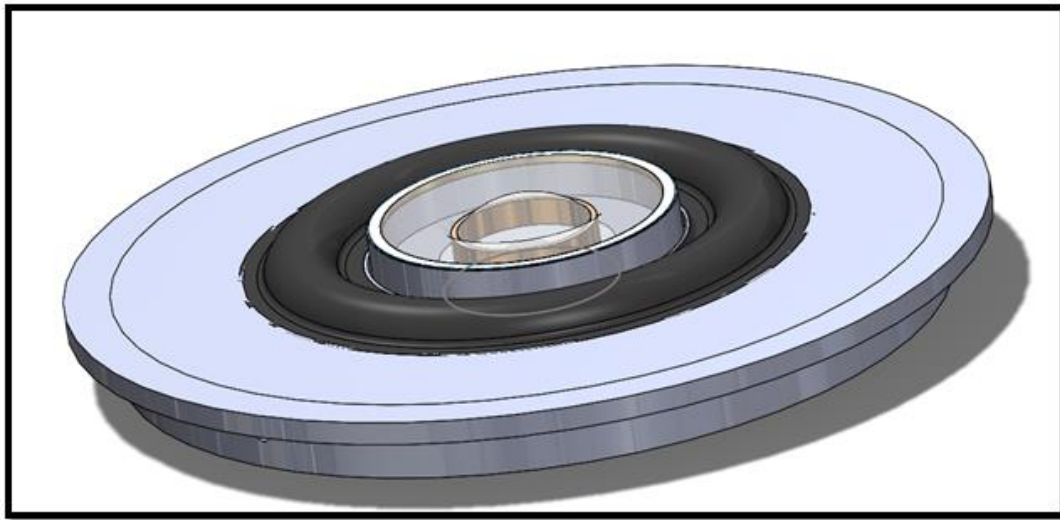

*Figure 23: 2016/2017's final dual passive radiator speaker box [7]*

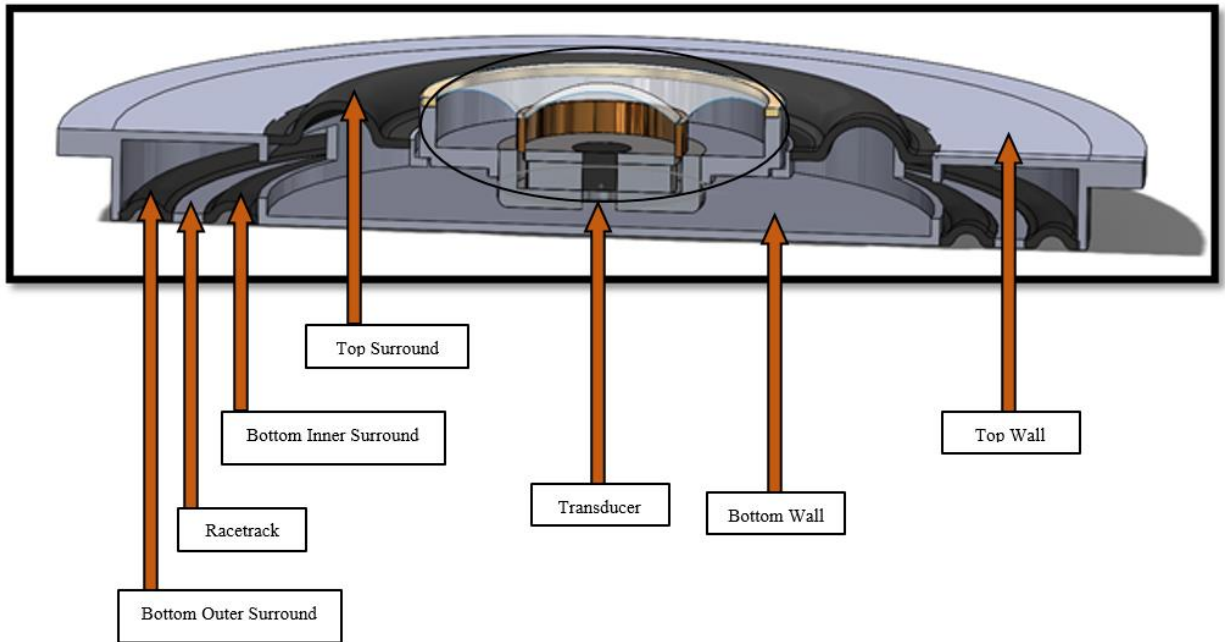

Figure 24: Labeled cross section view of 2016/2017's final dual passive radiator design [7]

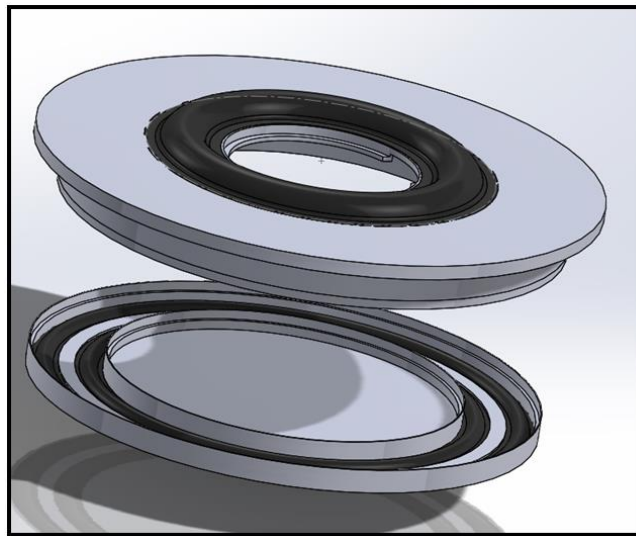
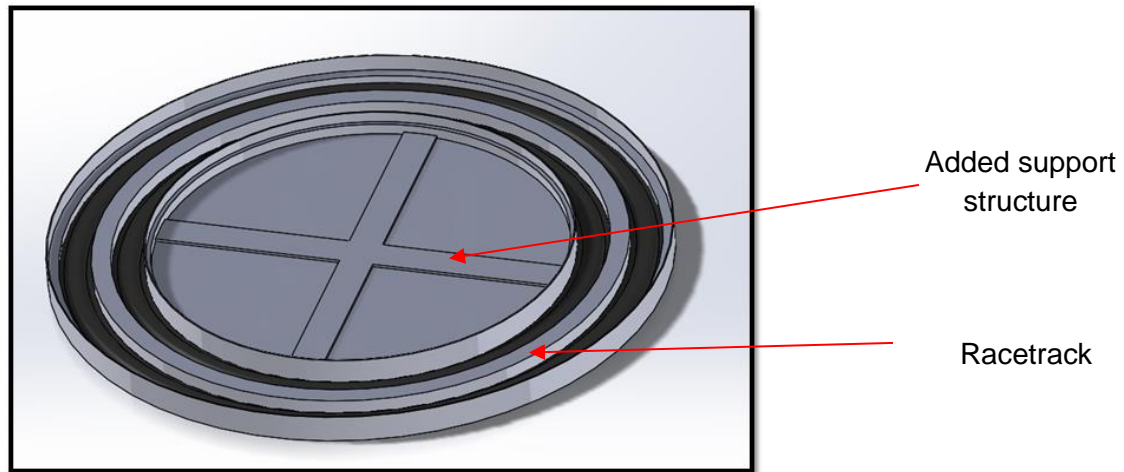

Figure 25: Top and bottom half of 2016/2017's final dual passive radiator design [7]

Our team first tested this design with the Polytec Scanning Vibrometer in order to assess how well the speaker box was working. After viewing the results it was noticed that the back rigid center of the box was vibrating too much and that the racetrack needed to be thicker. As a result, the racetrack was

increased from 1 mm to 3 mm in thickness and additional supports were added to the bottom assembly as shown in Figure 26.



*Figure 26: Improved bottom assembly for 2016/2017's final dual passive radiator design*

Before starting on new designs and further improvements, all of the sub-teams presented their work from the first quarter of the 2017-2018 school year at the Bose headquarters in Framingham Massachusetts. For our sub-team's presentation, a slideshow and display was made (shown in Figure 27) that combined the work done on the various prototyped speakers so far. This was done to prove the capabilities of our project and to get input for our future work.

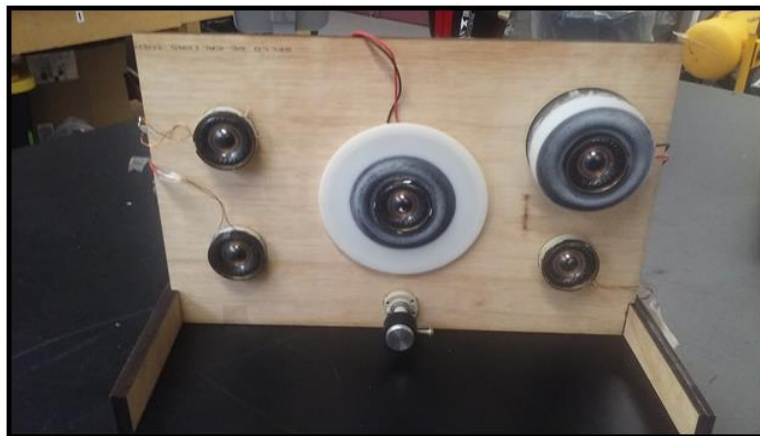

*Figure 27: Display made for Initial Bose Presentation incorporating 2016/2017's designs and initial designs from this project*

## 4.2 Computer Modeling

In this section, results from both PSpice and Simscape are discussed in detail to show the ultimate reasoning behind converting to use MatLab's Simscape as our primary computer modeling software.

### 4.2.1 PSpice

Early on in this project, PSpice was utilized for acoustic modeling. This helped was intended to assist us in predicting the acoustic behavior of our speaker system and to ultimately optimize our speaker box design. Initially, a simple transducer was modeled using PSpice and then compared to the speaker spec-sheet to confirm the validity of the PSpice model. The transducer modeled is the Satin2 40mm micro-driver that was used in the 2016-2017 designs. Figure 28 shows the spec-sheet for the micro-driver

Parameter	Value
Re [ohm]	22.29
Le1 [H]	1.42E-04
Le2 [H]	1.30E-04
Rle1 [ohm]	2.43E+13
Rle2 [ohm]	2.80
Lces	2.44E-02
Cmes	5.26E-05
Res	48.63
BL [N/A]	2.50
Mms [kg]	3.28E-04
Cms [m/N]	3.91E-03
Rms [N/(m/s)]	1.28E-01
r_ms [(m/s)/N]	7.79
Fs [Hz]	140.66
Beta [N <sup>2</sup> /W]	2.80E-01
Sd [m <sup>2</sup> ]	7.43E-04
Effective Diameter [mm]	30.75
Equivalent Acoustic Volume [cc]	302.87

Figure 28: Satin2 40mm micro-driver spec-sheet

From Figure 28,  $F_s$  represents the resonant frequency of the micro-driver, which is confirmed by the results of the PSpice model shown in Figure 29.

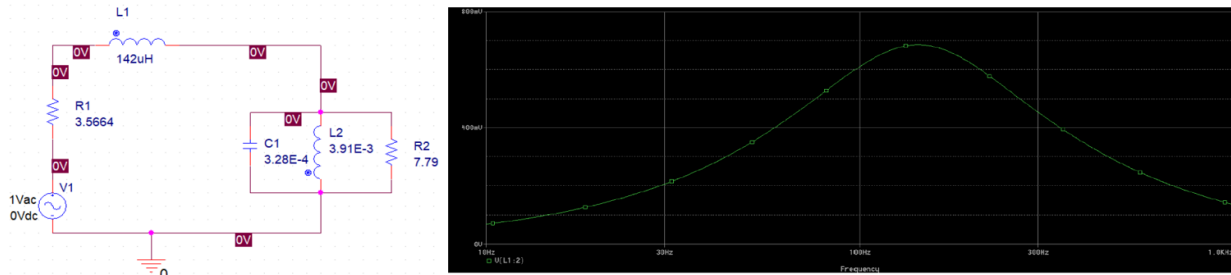

Figure 29: PSpice Model and Results for Satin2 40mm Micro-driver

After the modeling the simple transducer and confirming the results from its spec-sheet, a single passive radiator system was modeled using the micro-driver. In this model, the passive radiators compromise the entire area of bottom of the speaker. Fs values for both the transducer and passive radiator were found. Figure 30 displays the model and Figure 31 shows that the Fs of the passive radiator (in white curve) is lower than the Fs of the transducer (in red curve), which is expected.

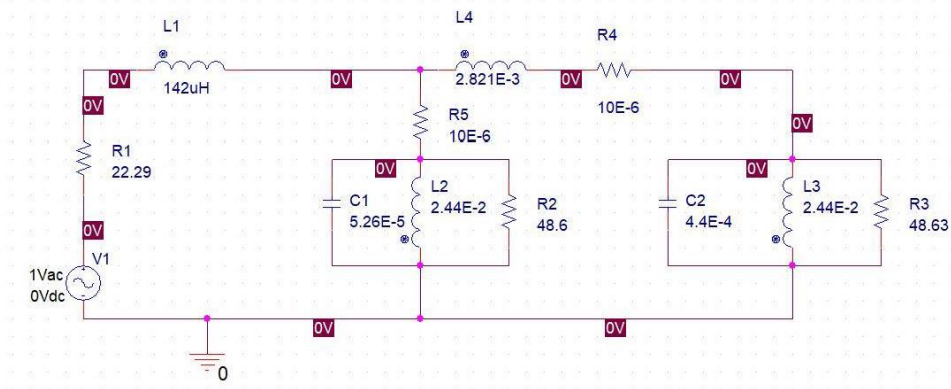

Figure 30: PSpice model of the single passive radiator system

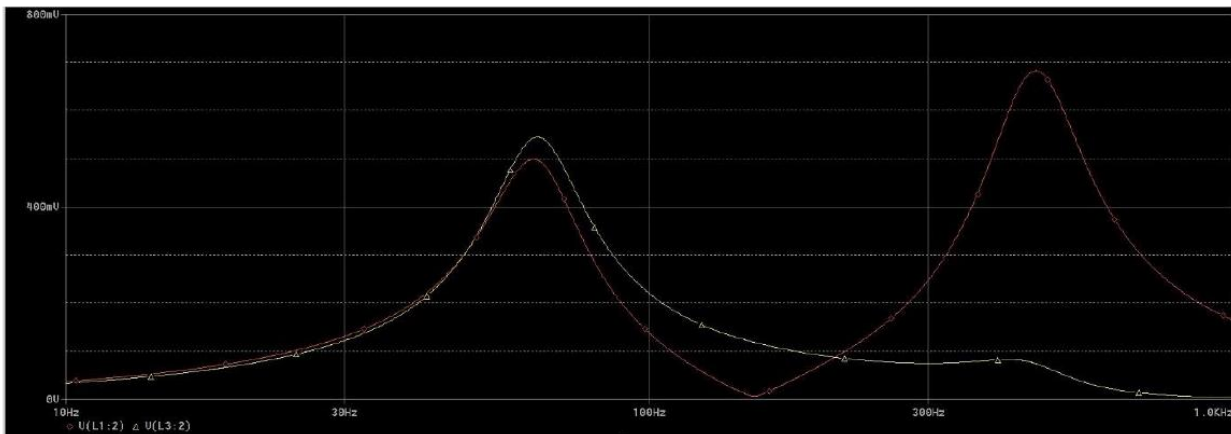

Figure 31: PSpice Results for the single passive radiator system

Now that we have modeled a single passive radiator system, we attempted to model a force balanced double passive radiator using PSpice. However, due to lack of literature on electro-mechano-acoustic modeling of double passive radiator systems, the team has struggled to represent the system accurately to reflect the results from the scanning Vibrometer. Therefore, the team decided to switch to a more intuitive program where one can model speaker system physically in the mechanical domain without the need to switch between mechanical, acoustical, and electrical domains, which is done in PSpice.

#### 4.2.2 Simscape

For the final Simscape design, a combination of hydraulic, mechanical, gas and thermal systems were utilized. The speaker and passive radiators were modeled by spring-mass-damper systems. The front passive radiator and the speaker were set-up as a double mass-spring-damper system, each connected to a “Translational Mechanical Converter,” or an air spring. The Translational Mechanical Converter acts as an interface between a mechanical translational and a gas network. The Translational Mechanical Converter inputs the translational mechanical network and outputs into three ports: a thermal conserving port, a gas conserving port, and a mechanical translation conserving port. Since the speaker system should not experience a lot of varying environmental changes, the thermal conserving port leads to an ideal insulator (or “perfect insulator”), which prevents heat exchange from occurring in the model. The mechanical translation conserving port is connected to the grounded reference point. The gas conserving port leads to Constant Volume Chamber that represents the volume of the speaker box. The rear passive radiator is set up as a single mass-spring-damper system with a Translational Mechanical Converter that leads to the same Constant Volume Chamber as the front passive radiator and speaker.

Figure 32 presents the final Simscape design. An analysis input port is entered onto the signal that is inputted into the Ideal Force Source. The output port is located on the Rear Passive Radiator position chart. The analysis ports are used to perform a linear analysis of the model. Figure 33 presents the linear analysis of the final Simscape model using the parameter values from the Moving Magnet Design 1



Version 4, which is discussed later in the results section. The peak labeled represents a resonant frequency when the model was run. The resonant frequency calculated of the final moving magnet box design was 103 Hz compared to the Polytec Scanning Vibrometer resonant frequency of 85 Hz. Although the Simscape model projected a resonant frequency that matched the calculated, the linear analysis performed for this box design was very similar to a linear analysis for a design that incorporated the Daffodil speaker. A MathWorks employee, Professor Stabile, and a member of the team reviewed the Simscape model and believed it was set up correctly, however, more improvements can be made to get a more accurate representation of the speaker system.

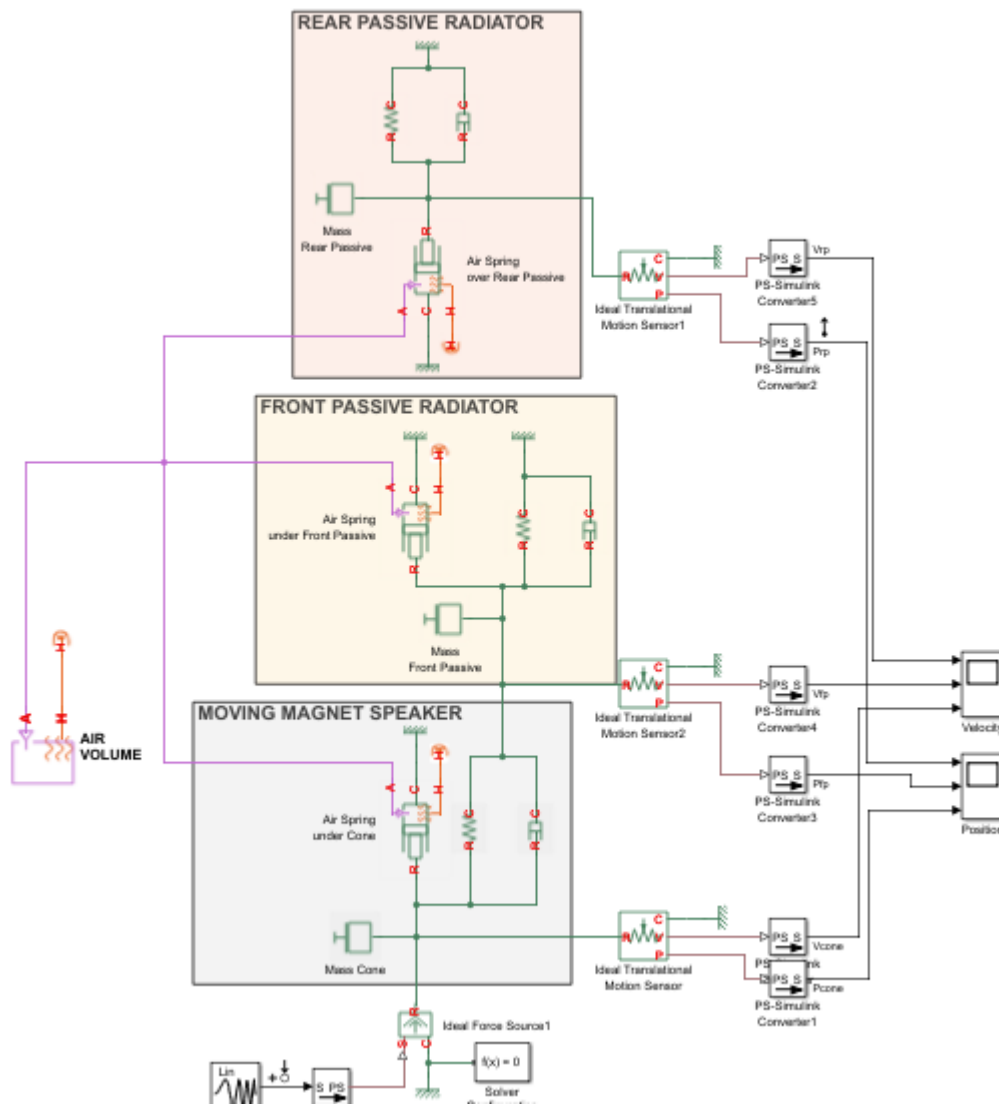

Figure 32: Final Simscape design of a dual passive radiator speaker box with a moving magnet transducer

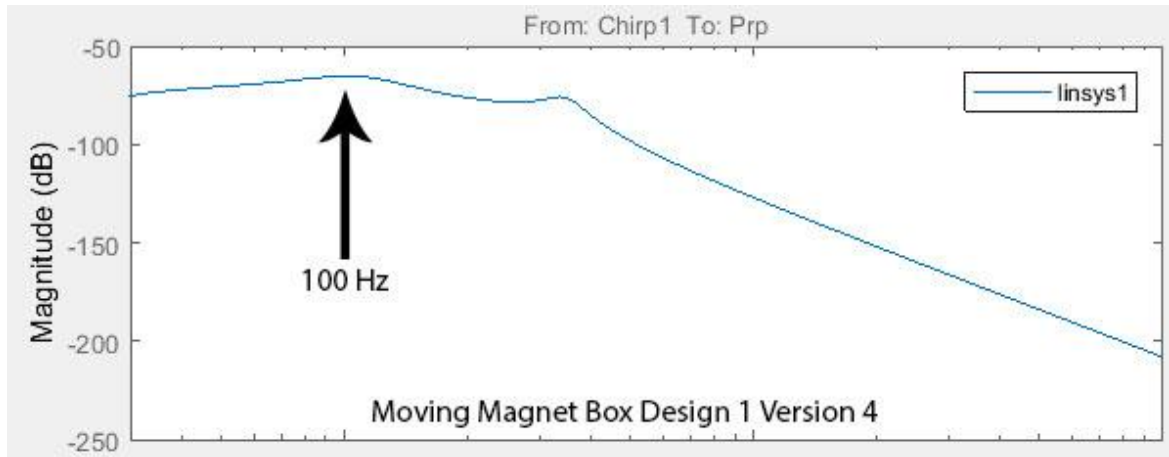

Figure 33: Linear analysis of the final dual passive radiator moving magnet box model

### 4.3 Daffodil Transducer Incorporation

The Daffodil transducers were obtained from Bose to assist with testing the prototypes. Figure 34 shows one of the Daffodil transducers. It is about 24 mm (0.95 inches) in thickness.



Figure 34: Daffodil transducer obtained from Bose Corporation

#### 4.3.1 Daffodil Box Design 1

##### Daffodil Box Design 1 Version 1

Design 1 version 1 (D1:V1), was a simple prototype used for proof of concept. It was used to familiarize our group with the fabrication process involved in creating prototypes, as well as testing a

more powerful transducer, than the one used in 2016/2017. The new transducer used, given to us by the Bose team, and was referred to as the Daffodil. To incorporate this new Daffodil transducer into our dual passive radiator design, D1:V1 was based off 2016/2017's speaker box design however, several changes were made. 2016/2017's team had shaped the top passive radiator to fit the profile of the transducer they were using. Since the new Daffodil transducer did not fit the circular shape used for 2016/2017's design, a new passive radiator needed to be designed for the top. The new passive radiator fit the oval profile of the Daffodil, but had a different area than 2016/2017's design. This involved changing the size of the bottom passive radiator to properly match the area of the new oval top passive radiator. The new racetrack needed to be larger in area, so the overall diameter was increased. Last, due to the bigger thickness of the Daffodil transducer, the overall height of D1:V1 was increased from 14.7 mm to 28.56 mm. This increase in thickness, as well as the increase in diameter (from 118.86 mm to 169.58 mm), lead D1:V1 to have roughly twice the acoustic volume of 2016/2017's design. Polytec Scanning Vibrometer testing was performed on D1:V1 and resulted with scans of the front and back passive radiators shown in appendix D. These scans, while promising for the first test scans, showed a lack of support which caused sound distortion. In an ideal box design, the passive radiators will oscillate, while the rest of the box will remain rigid. As seen in the scans, the passive radiators do oscillate, however, due to the thinness of the walls, so do areas of the speaker box. Figure 35 shows the CAD model of this design. Figure 36 shows the labeled cross section view of this design. Figure 37 the 3D printed prototype of this design. See Table 2 for the specifications of this design. Figure 38 shows two Polytec Scanning Vibrometer scans of this design with a Daffodil transducer. Figure 39 shows two slow motion video screen shots of this design with a Daffodil transducer.

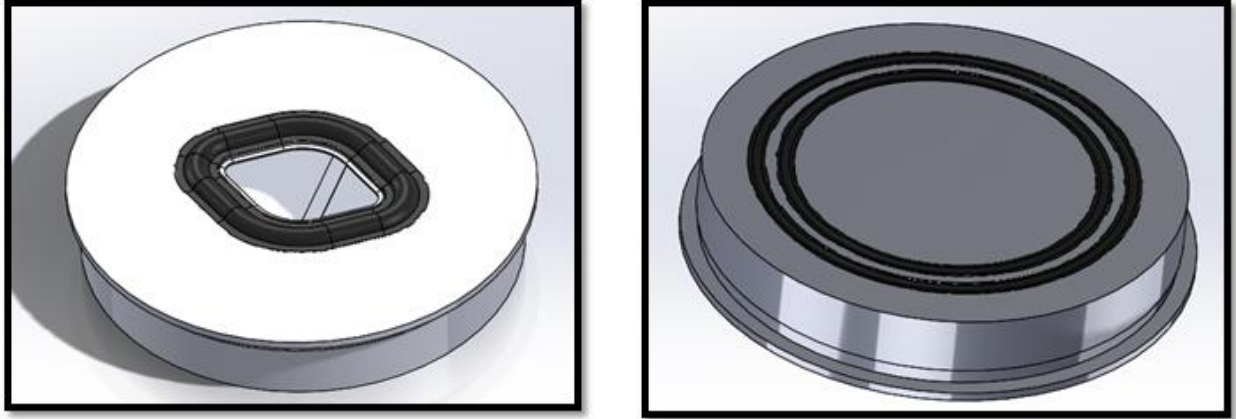

Figure 35: Daffodil Box Design 1 Version 1 CAD model

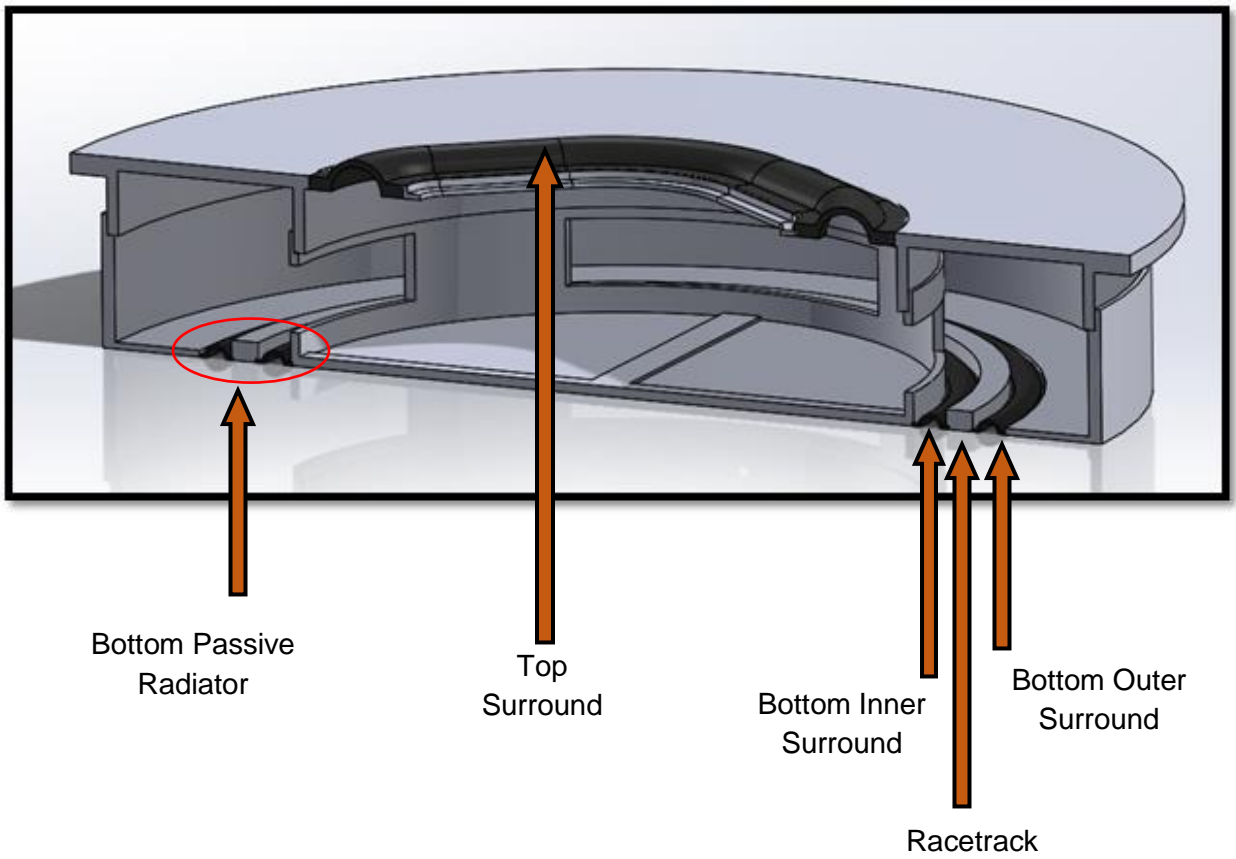

Figure 36: Labeled section view of Daffodil Box Design 1 Version 1

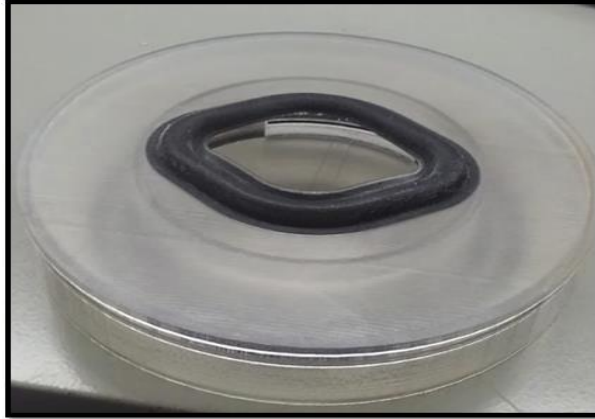

Figure 37: Daffodil Box Design 1 Version 1 3D Printed Prototype

Table 2: Daffodil Box Design 1 Version 1 Specifications

<b><u>Daffodil Box Design 1 Version 1 Specifications</u></b>	
Objet Materials	Rigid: VeroClear; Flexible: TengoBlackPlus
Overall Thickness	32.45 mm (1.28 inches)
Overall Diameter	161.9 mm
Intended Transducer	Daffodil
Top Surround Thickness	1 mm
Bottom Surrounds Thickness	0.5 mm
Racetrack Thickness	3 mm
Bottom Wall Thickness	1 mm
Top Wall Thickness	1.77 mm
Approx. Air Volume	28.16 cubic inches
3d Printed	Yes
Resonant Frequency	--
Additional Features	<ul style="list-style-type: none"> <li>● Bottom wall cross support</li> <li>● Modified Top Surround</li> <li>● Adjusted Air volume &amp; Passive areas</li> </ul>



Figure 38: Daffodil Box Design 1 Version 1 Polytec Scanning Vibrometer scans



Figure 39: Daffodil Box Design 1 Version 1 Polytec Scanning Vibrometer slow motion video screen shots

## Daffodil Box Design 1 Version 2

Daffodil Box Design 1 Version 2 (D1:V2) was similar to D1:V1, with several modifications. In an effort to stiffen the speaker box and create a better quality of sound, D1:V2 was created. D1:V2 changed the bottom wall thickness from 1mm to 2mm. This added stiffness was done in hopes of preventing the undesired movement in D1:V1, therefore making the passive radiators more efficient. Based on ANSYS simulations and testing, the top surround was also increase to 2 mm in thickness in order to add support for the flexible material to support the Daffodil transducer. Lastly to add even more rigidity to the speaker box, curved ribbed supporting was added to the center of the bottom plate. This was done to keep the bottom wall fixed and rigid, as in previous scans the entire bottom wall had oscillated with the passive radiator. Figure 40 shows a labeled cross section view of this design and Figure 41 shows the 3D printed assembly. Table 1 lists the specifications of this design. Figure 42 and Appendix E shows the Polytec Vibrometer scan data from this design. This was the final version of this design.

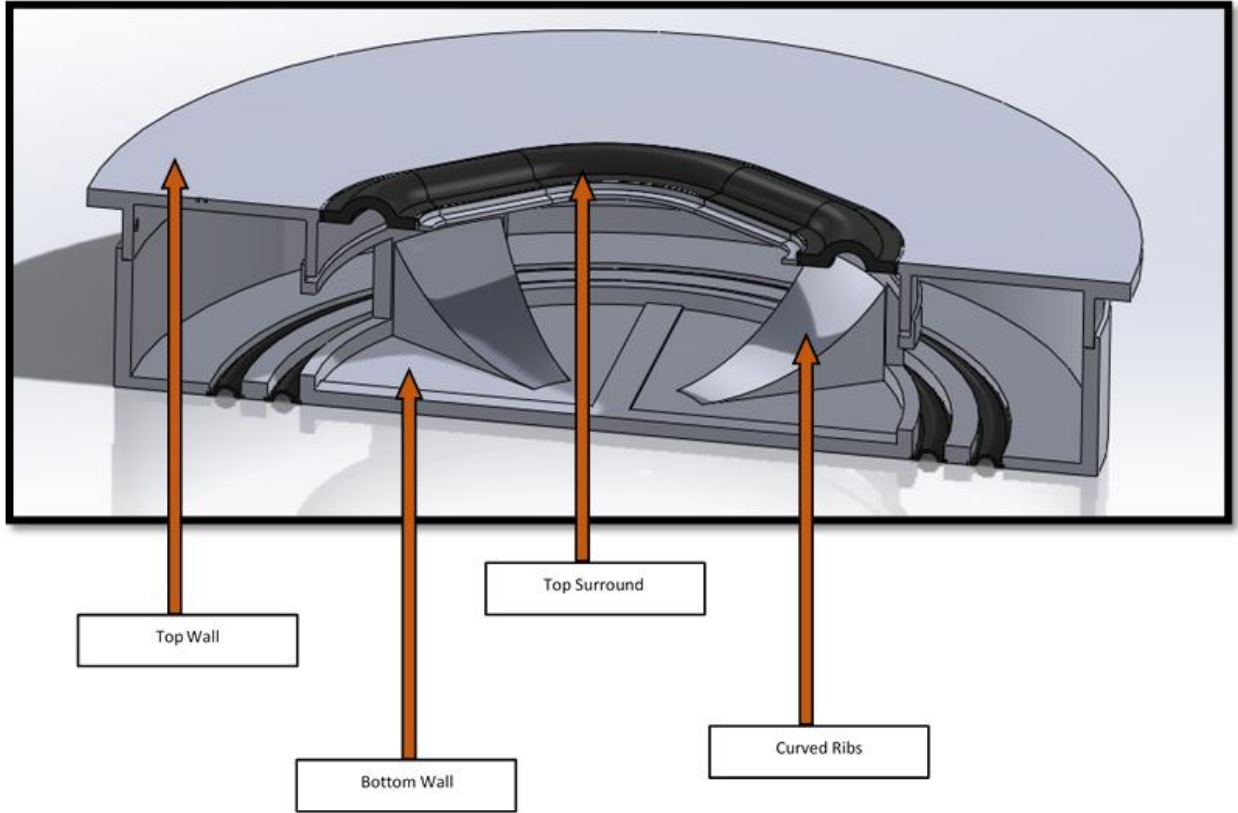

Figure 40: Daffodil Box Design 1 Version 2 labeled CAD model

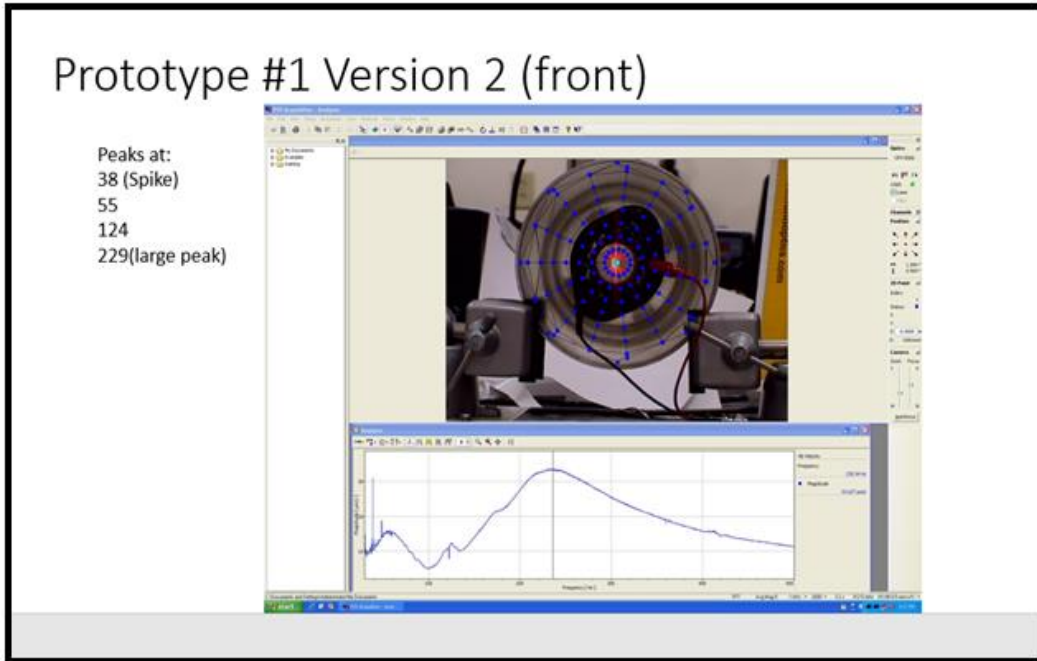

Figure 41: Daffodil Box Design 1 Version 2 3D printed prototype



Table 3: Daffodil Box Design 1 Version 2 Specifications

<b><u>Daffodil Box Design 1 Version 2 Specifications</u></b>	
Objet Materials	Rigid: VeroClear; Flexible: TengoBlackPlus
Overall Thickness	31.56 mm (1.24 inches)
Overall Diameter	149.47 mm
Intended Transducer	Daffodil
Top Surround Thickness	2 mm
Bottom Surrounds Thickness	0.5 mm
Racetrack Thickness	3 mm
Bottom Wall Thickness	2 mm
Top Wall Thickness	2 mm
Approx. Air Volume	--
3d Printed	Yes
Resonant Frequency	--
Additional Features	<ul style="list-style-type: none"> <li>● Bottom wall thickness increased</li> <li>● Top surround thickness increased</li> <li>● Added curved support ribs</li> </ul>



*Figure 42: Daffodil Design 1 Version 2 sample Polytec Scanning Vibrometer scan*

#### 4.3.2 Daffodil Box Design 2

##### Daffodil Box Design 2 Version 1

This prototype was designed simultaneously to Design 1 to allow the team to determine what the best design to use was. Similar to the first design, this design's thickness and diameter were also increased to incorporate the Daffodil transducer. The major difference with this design was that the “wings” of the Daffodil transducer were removed and an additional ring was attached to the Daffodil. This allowed for the top surround to retain its circular shape. Figure 43 shows this design and its cross section. Table 4 shows the specifications of this design.

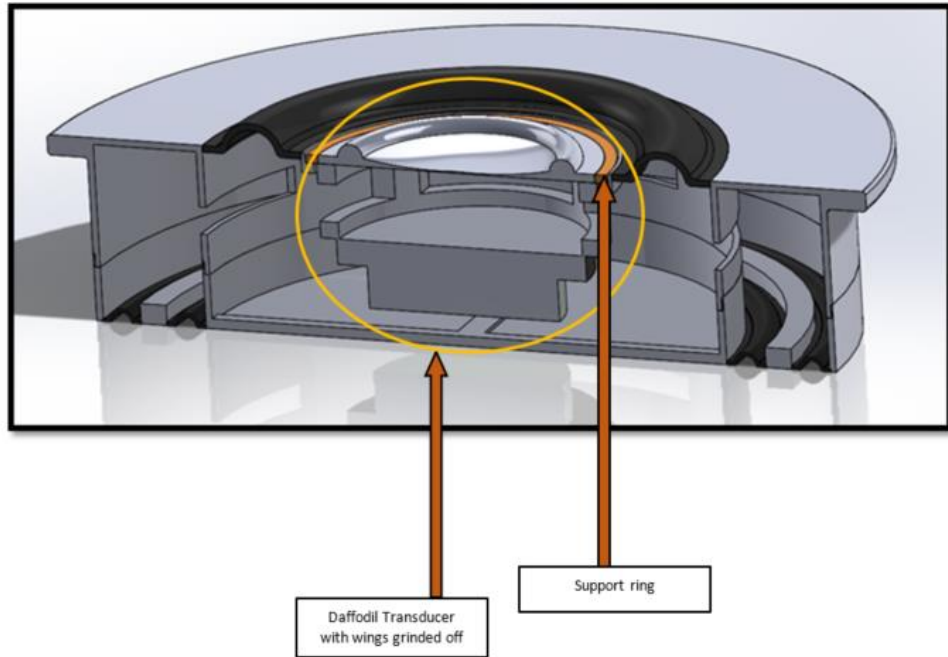

Figure 43: Daffodil Box Design 2 Version 1 labeled cross section view

Table 4: Daffodil Box Design 2 Version 1 Specifications

<b><u>Daffodil Box Design 2 Version 1 Specifications</u></b>	
Objet Materials	Rigid: VeroClear; Flexible: TengoBlackPlus
Overall Thickness	30.95 mm (1.22 inches)
Overall Diameter	124 mm
Intended Transducer	Daffodil
Top Surround Thickness	1 mm
Bottom Surrounds Thickness	0.5 mm
Racetrack Thickness / weight	3 mm / 3.51 g
Bottom Wall Thickness	1 mm
Top Wall Thickness	1 mm
Approx. Air Volume	--

3d Printed	Yes
Resonant Frequency	--
Additional Features	

### Daffodil Box Design 2 Version 2

After analysis with the Polytec Scanning Vibrometer, it was determined that the bottom half needed more support. So, ribs were added that connected the center walls to the rigid bottom wall of the box. Another modification to this design was the incorporation of a twist lock fit to secure the top and bottom assemblies. The twist lock fit worked by first lining up the extruded pegs on the top assembly with their respective slots on the bottom assembly and subsequently twisting the entire assembly together. This design performed better but still needed more support. Figure 44 shows this design's cross section view and Figure 45 shows the 3d printed prototype. Table 5 lists this design's specifications. Figure 46 and Appendix F shows Polytec Vibrometer scans of this design.

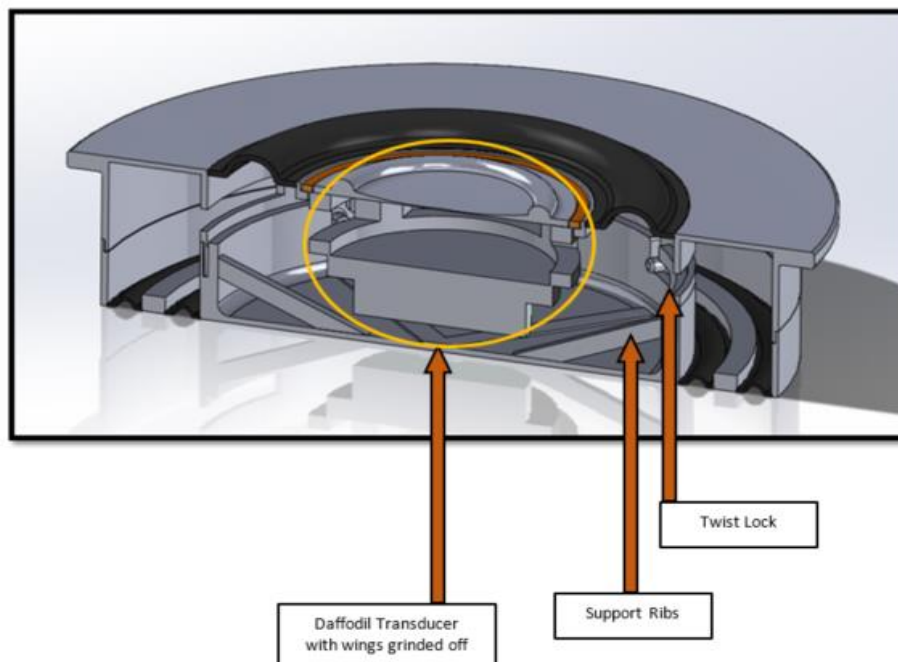

Figure 44: Daffodil Box Design 2 Version 1 labeled cross section view



Figure 45: Daffodil Box Design 2 Version 1 3D printed prototype

Table 5: Daffodil Box Design 2 Version 1 specifications

<b><u>Daffodil Box Design 2 Version 2 Specifications</u></b>	
Objet Materials	Rigid: VeroClear; Flexible: TengaBlackPlus
Overall Thickness	30.95 mm (1.22 inches)
Overall Diameter	125.1 mm
Intended Transducer	Daffodil
Top Surround Thickness	1 mm
Bottom Surrounds Thickness	0.5 mm
Racetrack Thickness/weight	3 mm
Bottom Wall Thickness	1.11 mm
Top Wall Thickness	1 mm
Approx. Air Volume	--
3d Printed	Yes
Resonant Frequency	--
Additional Features	<ul style="list-style-type: none"> <li>● Support ribs</li> <li>● Twist lock</li> </ul>

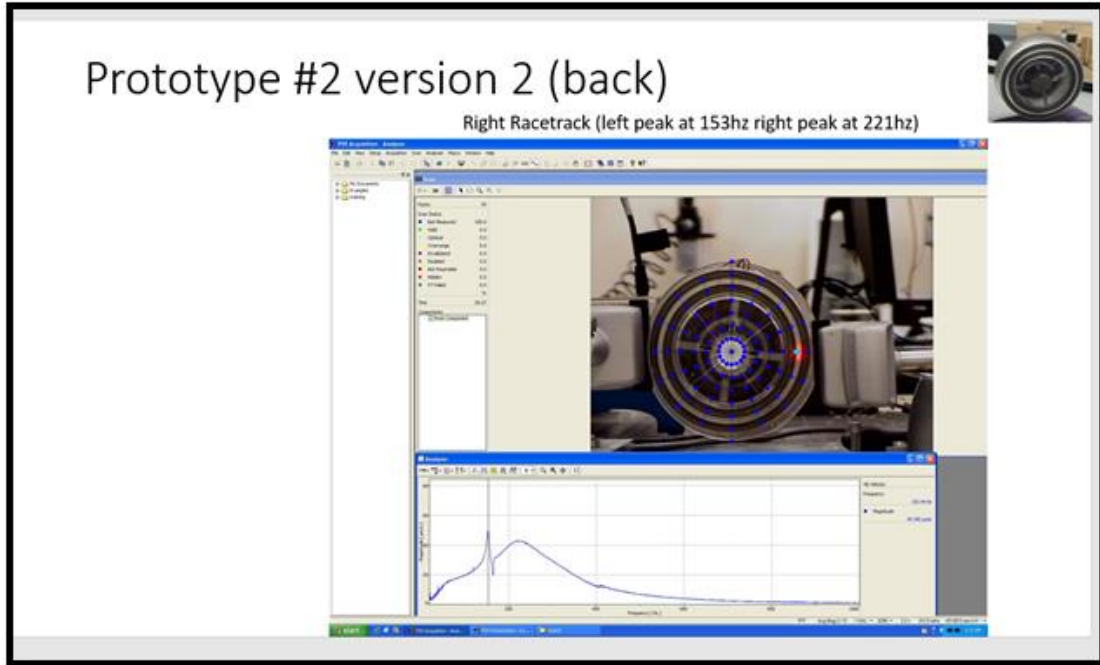

Figure 46: Daffodil Box Design 2 Version 2 sample Polytec Scanning Vibrometer Scans

### Daffodil Box Design 2 Version 3

The third version of this design added even more support. The ribs were increased in size and a circular rib was added in the center that attached to the outer ribs. ANSYS simulations showed better structural support and harmonic response of the speaker box. Figure 49 shows the maximum deflection to be around  $1.2 \times 10^{-5}$  meters. Figure 50 shows almost no vibration of the rigid material when it undergoes a frequency up to 500 Hz. This design performed much better than the previous versions. The resonant frequency of this design was determined to be approximately 90 Hz. Appendix G shows the Polytec scans of this design. Figure 47 shows this design's cross section view and Figure 48 shows the 3D printed prototype with the Daffodil transducer in the center. Table 6 lists this design's specifications. Figure 51 and Figure 52 show Polytec Scanning Vibrometer scans of this design. This prototype is also demonstrated at the following link:

<https://drive.google.com/open?id=1Iz0bv0b8V8wMSGFa4t1IgWRlhfo8XVYP>

While it will be heard through a second set of speakers, the video does a good job at comparing first the Daffodil transducer alone and then the Daffodil transducer enclosed in this speaker box design.

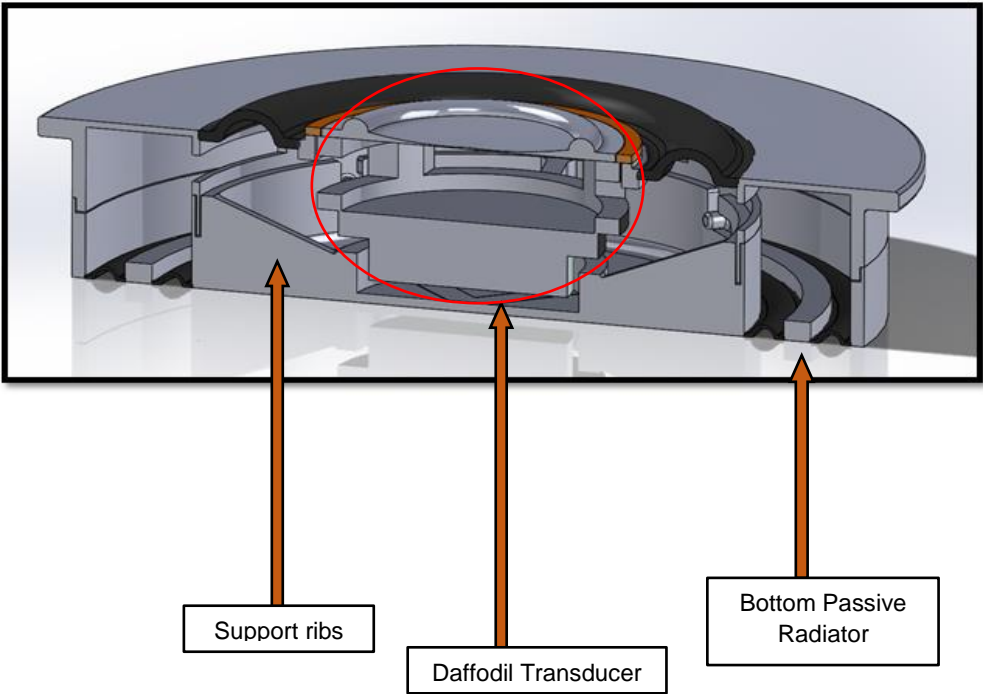

Figure 47: Daffodil Box Design 2 Version 3 cross section view

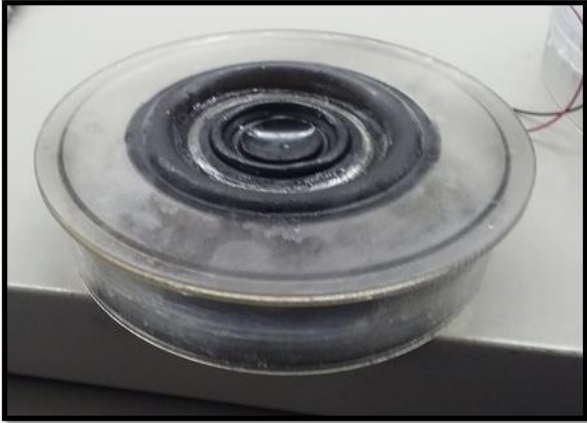

Figure 48: Daffodil Box Design 2 Version 3 3D Printed Prototype

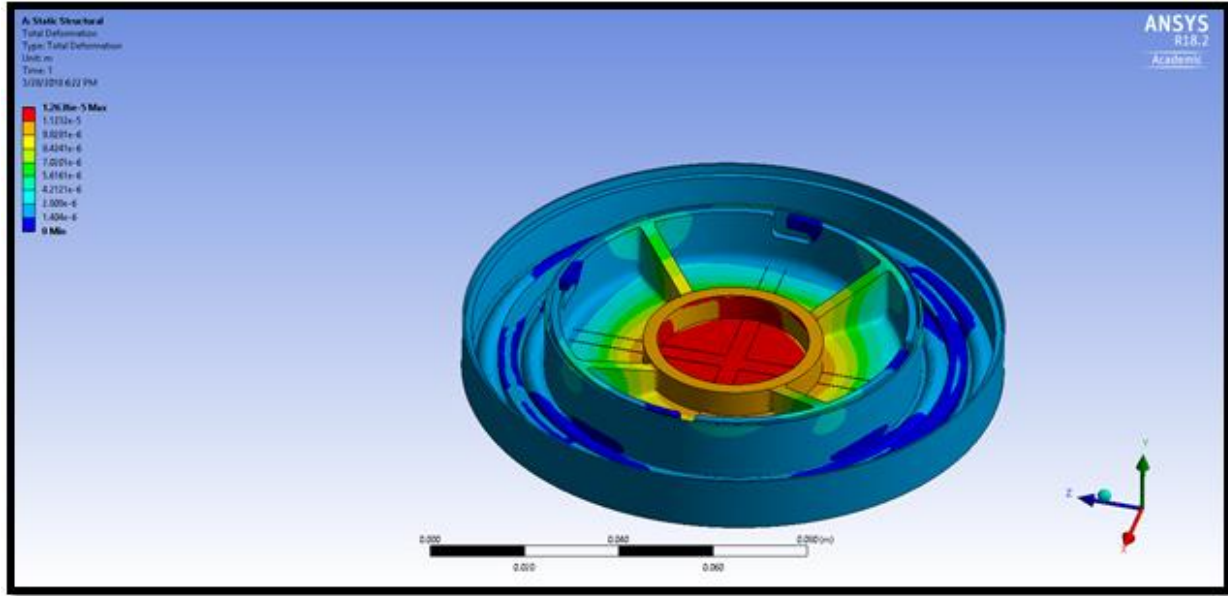

Figure 49: ANSYS structural simulation of Daffodil Box Design 2 Version 3

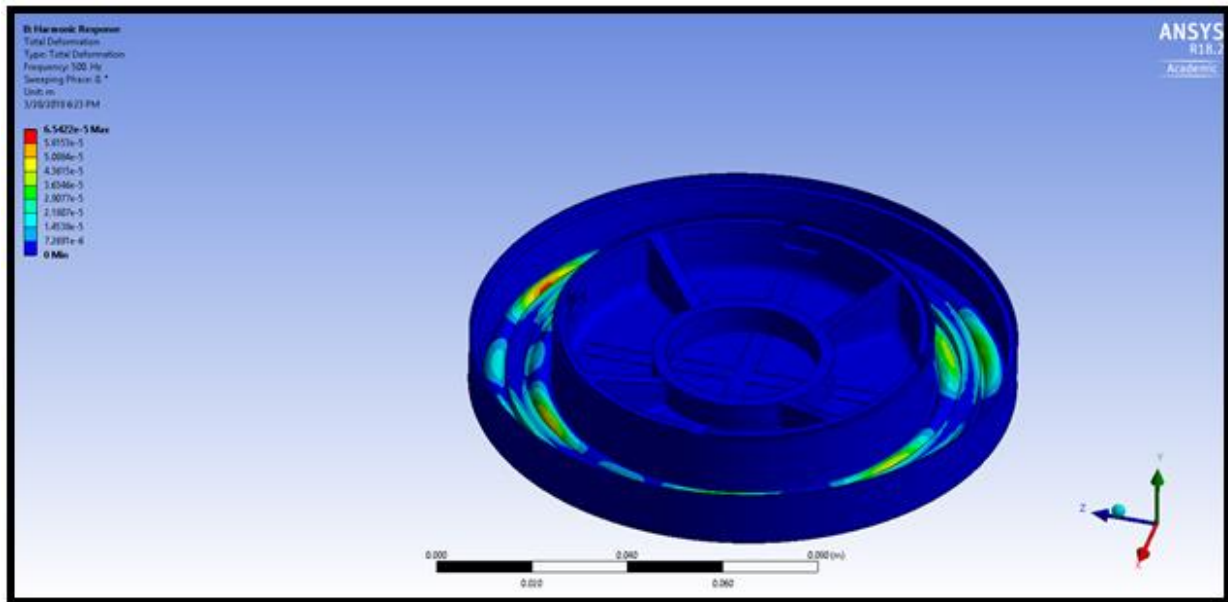

Figure 50: ANSYS harmonic response simulation of Daffodil Box Design 2 Version 3



Table 6: Daffodil Box Design 2 Version 3 Specifications

<b><u>Daffodil Box Design 2 Version 3 Specifications</u></b>	
Objet Materials	Rigid: VeroClear; Flexible: TengoBlackPlus
Overall Thickness	27.55 mm (1.08) inches
Overall Diameter	125.1mm
Intended Transducer	Daffodil
Top Surround Thickness	1.5 mm
Bottom Surrounds Thickness	0.5 mm
Racetrack Thickness / weight	3mm / 3.55g
Bottom Wall Thickness	1.41 mm
Top Wall Thickness	1 mm
Approx. Air Volume	5.67 cubic Inches
3d Printed	Yes
Resonant Frequency	90 Hz
Additional Features	<ul style="list-style-type: none"> <li>● Improved support ribs</li> <li>● Adjusted top surround</li> </ul>

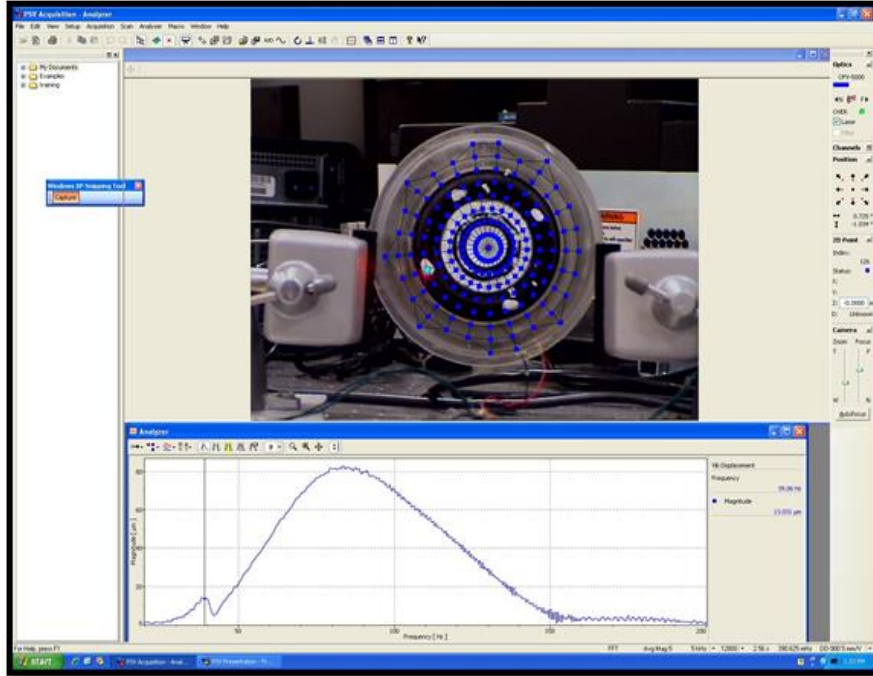

Figure 51: Daffodil Box Design 2 Version 3 sample front Polytec Scanning Vibrometer scan

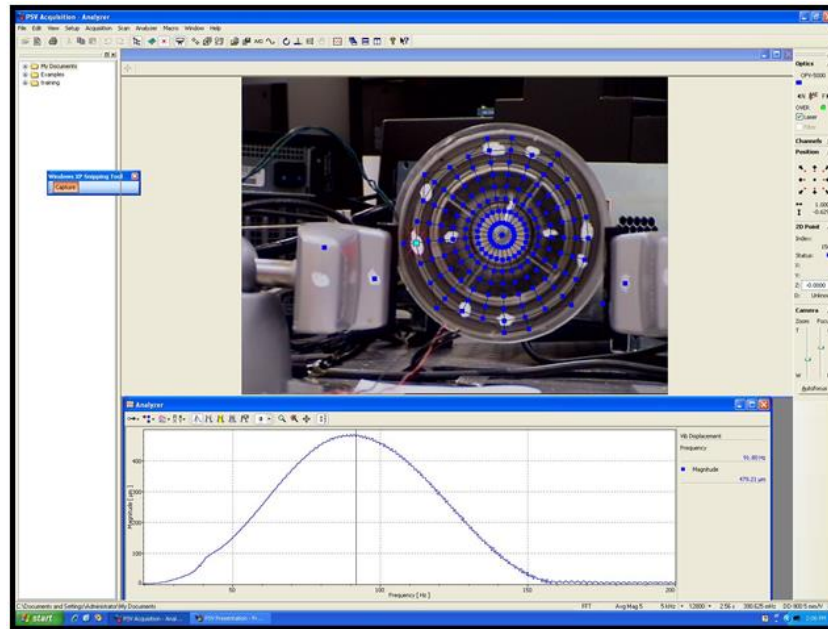

Figure 52: Daffodil Box Design 2 Version 3 sample back Polytec Scanning Vibrometer scan

## 4.4 Moving Magnet Transducer Incorporation

### 4.4.1 Moving Magnet Box Design 1

#### Moving Magnet Box Design 1 Version 1

This design was made to house the Moving Magnet sub-team's transducer design. This new box incorporated all design features gathered from earlier prototypes. It additionally raised the bottom passive radiator and added perimeter slots in order to reduce thickness and improve sound quality, respectively, as shown in Figure 53. The slots were to allow sound generated by the back passive radiator to escape out the front and not be cancelled out by any surface the speaker is mounted too. Learning from previous prototypes, the top surround's thickness was increased to 1.5 mm thick to accommodate for the extra weight that the Moving Magnet transducer introduces, since stiffness is proportionally related to the thickness raised to the third power. Curved ribbing was added to the inside surface of the speaker box for additional rigidity. To allow this part to print it was designed as two parts with a lock fit mechanism to hold it together. The overall thickness of this prototype was approximately 21 mm (or 0.827 in). Below, the cross section view of this design is shown which incorporates the Moving Magnet transducer. Table 7 lists this design's specifications. This design was not 3d printed because the final Moving Magnet transducer design was not finalized.

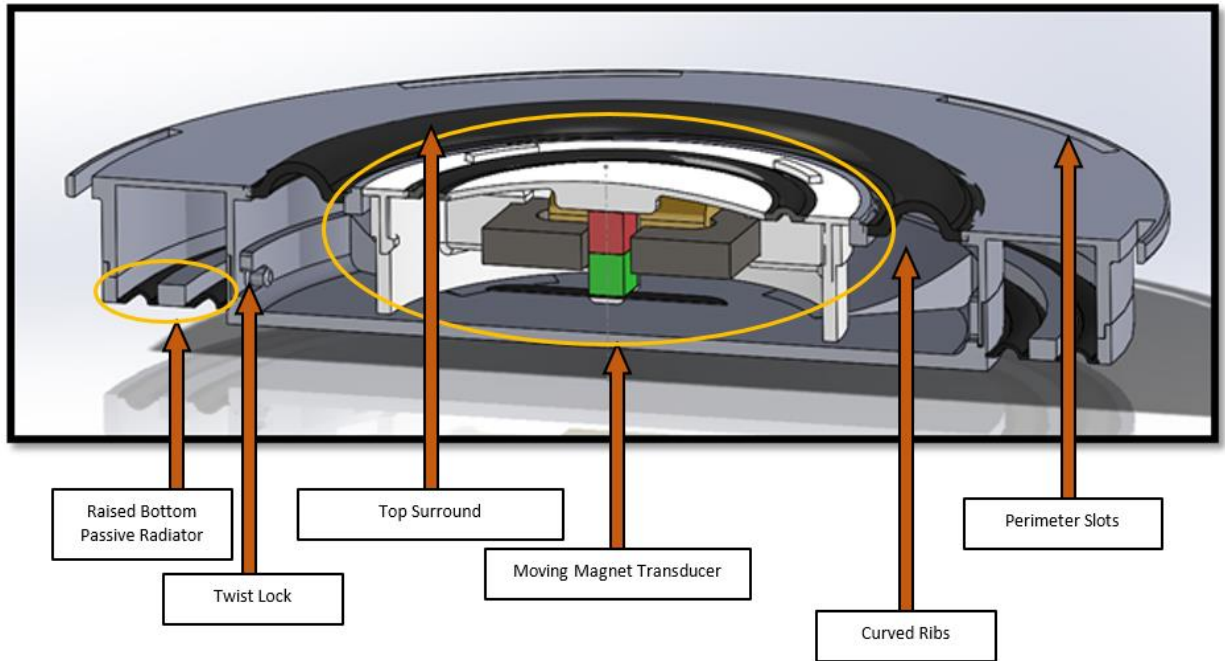

Figure 53: Moving Magnet Box Design 1 Version 1 cross section view

Table 7: Moving Magnet Box Design 1 Version 1 Specifications

<b><u>Moving Magnet Box Design 1 Version 1 Specifications</u></b>	
Overall Thickness	23.14 mm (0.911 inches)
Overall Diameter	152.36 mm
Intended Transducer	Moving Magnet
Top Surround Thickness	1.5 mm
Bottom Surrounds Thickness	0.5 mm
Racetrack Thickness / weight	3 mm / 4.57 g
Bottom Wall Thickness	2 mm
Top Wall Thickness	1 mm
Approx. Air Volume	--
3d Printed	No
Resonant Frequency	--

#### Additional Features

- Raised double passive
- First design to incorporate the moving magnet transducer
- Curved ribs
- Slots on outer perimeter for improved sound quality

#### Moving Magnet Box Design 1 Version 2

Version 2 of the Moving Magnet transducer box design raised the bottom passive radiator up further and subsequently increased the diameter to maintain the air volume. The maximum thickness of this design is remained at 21 mm (or 0.827 in). Figure 54 shows this design and Figure 55 shows the cross section view.

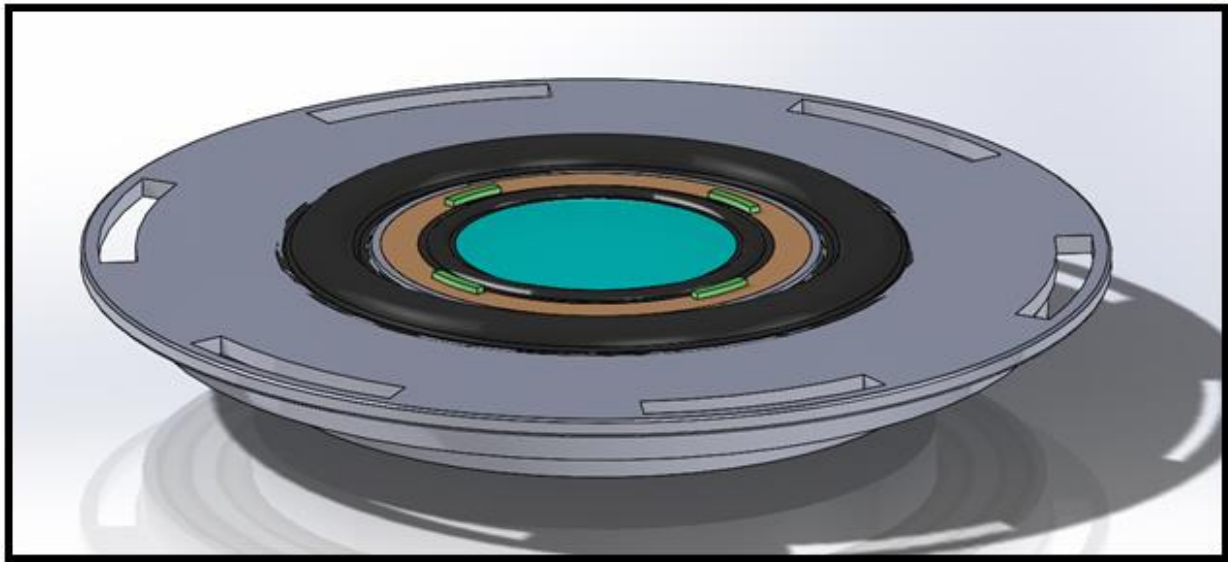

*Figure 54: Moving Magnet Box Design 1 Version 2 CAD model*

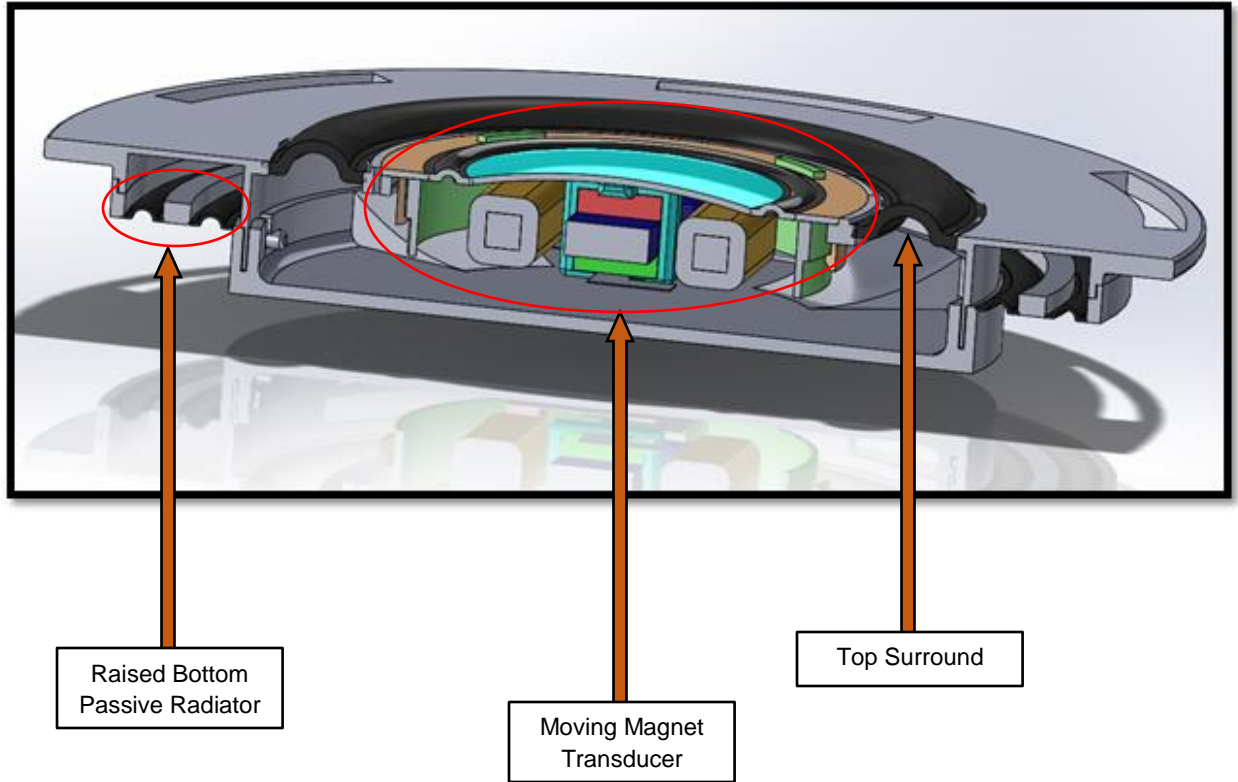

*Figure 55: Moving Magnet Box Design 1 Version 2 cross section view*

Additionally, a housing to fit a single box/transducer was designed in order for testing. The intended purpose of the housing was to allow sound to travel from the bottom passive radiator to the front side of the speaker. Figure 56 shows this frame design with the box/Moving Magnet transducer it and Figure 57 shows the cross-section view with the housing. Table 8 lists the specifications of this design.

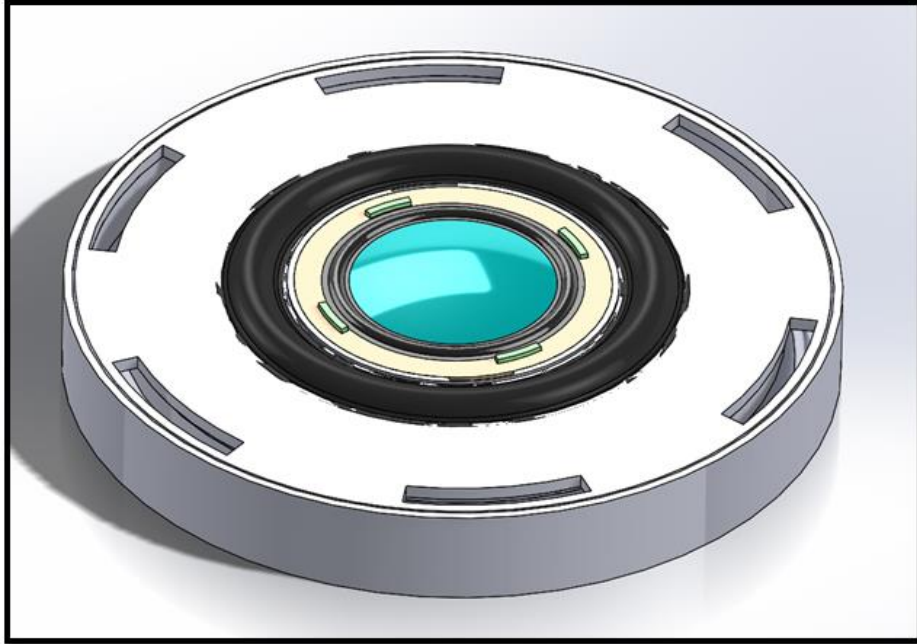

Figure 56: Daffodil Box Design 1 Version 2 with housing

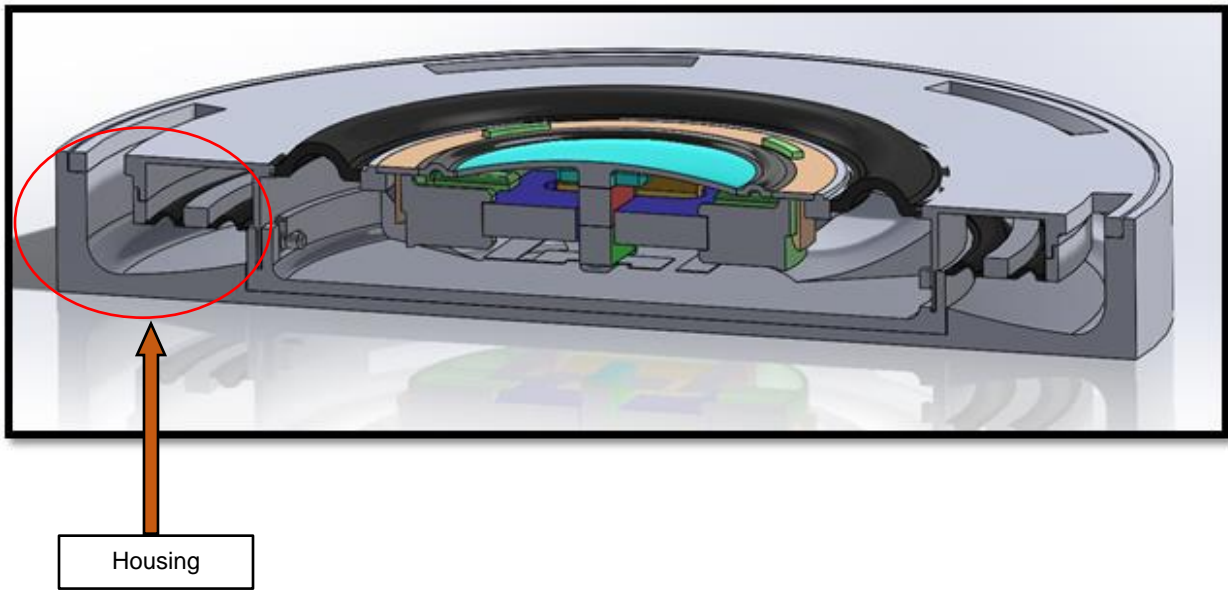

Figure 57: Daffodil Box Design 1 Version 2 with housing cross section view

Table 8: Moving Magnet Box Design 1 Version 2 Specifications

**Moving Magnet Box Design 1 Version 2 Specifications**

Overall Thickness	19.39 mm (0.76 inches)
-------------------	------------------------

Overall Diameter	164.48 mm
Intended Transducer	Moving Magnet
Top Surround Thickness	1.5 mm
Bottom Surrounds Thickness	0.5 mm
Racetrack Thickness / weight	3 mm / 4.65g
Bottom Wall Thickness	2 mm
Top Wall Thickness	1 mm
Approx. Air Volume	--
3d Printed	No
Resonant Frequency	--
Additional Features	<ul style="list-style-type: none"> <li>• Added a separate frame for the transducer/box combination to sit in</li> <li>• Thicker bottom wall</li> </ul>

### Moving Magnet Box Design 1 Version 3

Design 1 Version 3 of the Moving Magnet Box design had several changes from the last version. The Moving Magnet transducer was replaced in the SolidWorks Model with an updated version. This required that the overall thickness increase slightly to 22.39 mm. Additionally, the air volume inside the box was adjusted to be slightly larger than the Daffodil transducer box design 2 Version 3. This design also had a separate support structure to support a Daffodil transducer in place of the moving magnet transducer because the moving magnet transducer was still being fabricated. This was the first prototype of the raised bottom double passive that was 3d printed. Figure 58 and Figure 59 shows the CAD models of this prototype and Figure 60 shows the 3d printed prototype. As a note, the top surface of this speaker box cracked due to cleaning. It was repaired with sealing cement but the next designs will have the wall



thickness increased from 1mm to 2mm to prevent this from occurring again. Table 9 lists the specifications of this design.

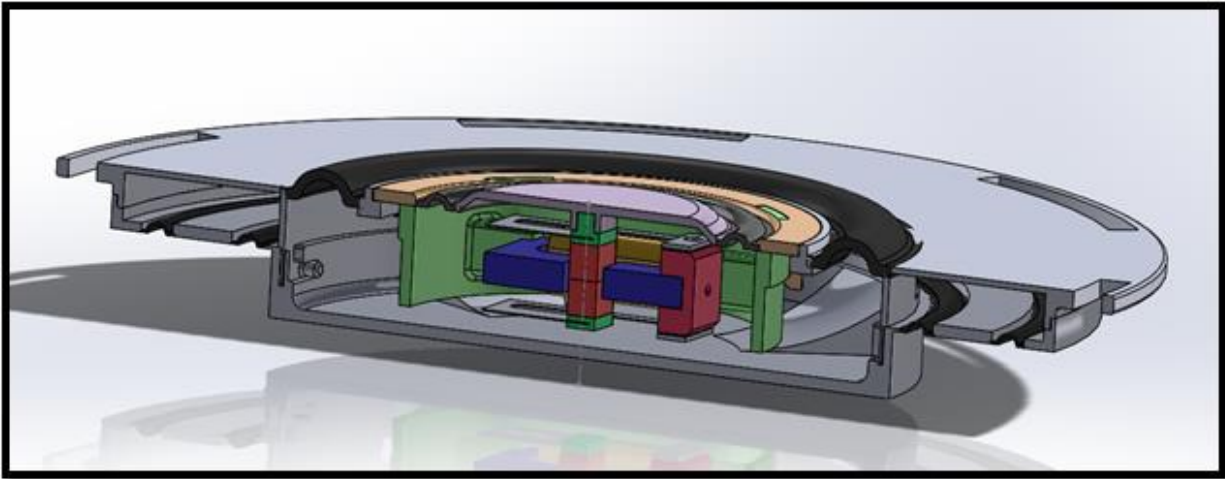

*Figure 58: Moving Magnet Box Design 1 Version 3 cross section*

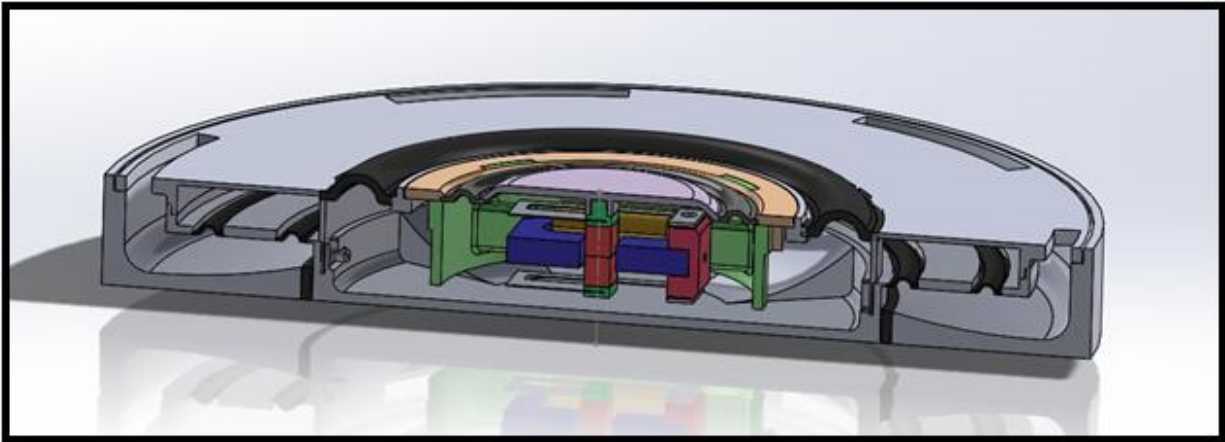

*Figure 59: Moving Magnet Box Design 1 Version 3 cross section with housing*

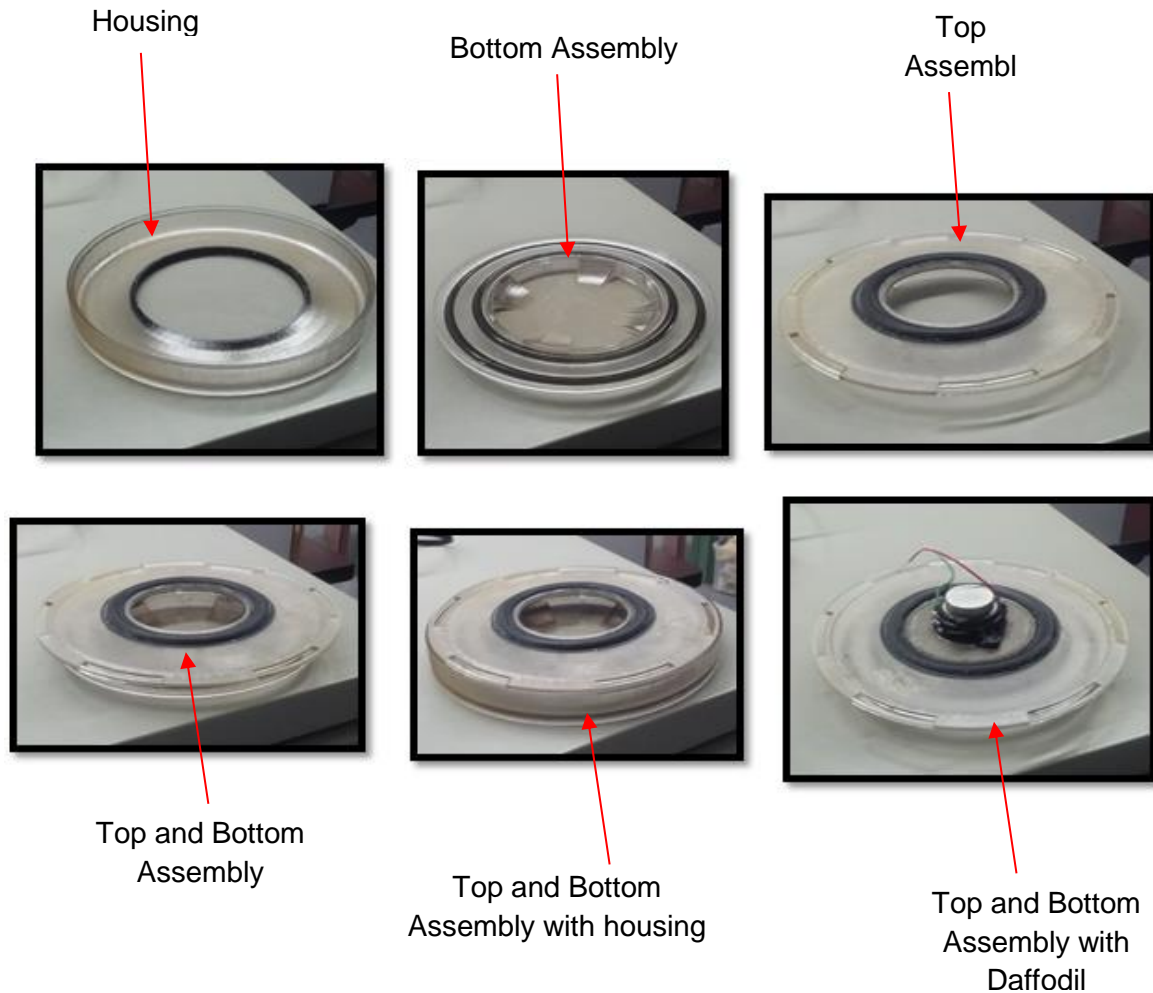

Figure 60: Moving Magnet Box Design 1 Version 3 3D printed prototype

After testing the speaker box with the Daffodil transducer siliconed to the box, a few areas were found that need improvement. First, since the area of the top and bottom passive radiators increased a significant amount, the measured resonant frequency was much higher (~140 Hz) than the 90 Hz as measured in the “non-raised” bottom passive design. As a result a large nut (~120 grams) was added to the transducer to increase its weight as shown in Figure 61. After retesting with the Vibrometer there was a slight decrease in the resonant frequency to ~137. The thickness of the top of the box may have also interfered with the Scanning Vibrometer results. Because of this, a cylinder of wood was laser cut and glued onto the top of the box as shown in Figure 61. This was retested with the Polytec Scanning Vibrometer and a slightly lower resonant frequency was attained.



Figure 61: Moving Magnet Box Design 1 Version 3 modified assembly

Table 9: Moving Magnet Box Design 1 Version 3 Specifications

<b><u>Moving Magnet Box Design 1 Version 3 Specifications</u></b>	
Objet Materials	Rigid: VeroClear; Flexible: TengoBlackPlus
Overall Thickness	22.39mm (0.881 inches)
Overall Diameter	186.16 mm
Intended Transducer	Moving Magnet or Daffodil
Top Surround Thickness	1.5 mm
Bottom Surrounds Thickness	0.5 mm
Racetrack Thickness / weight	2 mm / 8.75 g
Bottom Wall Thickness	2 mm

Top Wall Thickness	2 mm
Approx. Air Volume	13.86 cubic inches
3d Printed	Yes
Resonant Frequency	~137 Hz
Additional Features	<ul style="list-style-type: none"> <li>• Additional support for the Daffodil transducer</li> <li>• Improved frame</li> </ul>

#### Moving Magnet Box Design 1 Version 4

This version was the planned version to go into the final speaker system design, so six of these boxes were printed. It was similar to version 3 except that its top and bottom rigid walls were increased to 3 mm thick each, the curved ribs were decreased in size, the top surround was adjusted to 1.75 mm thick, and the design was slightly thicker to allow for the moving magnet transducer. The overall thickness of this design was about 24.4 mm thick and its overall diameter was about 186 mm. Figure 62 shows the CAD model of this design and Figure 63 shows its labeled cross section view. This design was printed without the housing as the housing did not have a significant effect on the sound quality during testing. Once the design was printed, a moving magnet transducer was implemented into it, wires were attached, and the box was sealed. This assembly process is shown in Figure 64. Table 10 lists the specifications for this design. This design was then tested with the Scanning Vibrometer. The Scanning Vibrometer test results showed a resonant frequency of about 90 Hz on both the front and back of all 6 of the 3d printed speaker boxes as shown in Figure 65, Figure 66, Figure 67 and appendix H. This scan video can also be viewed at the following link:

[https://drive.google.com/open?id=1WZ2H-48rz9f6G-4-BQBPhbK\\_ETDZUoj8](https://drive.google.com/open?id=1WZ2H-48rz9f6G-4-BQBPhbK_ETDZUoj8)

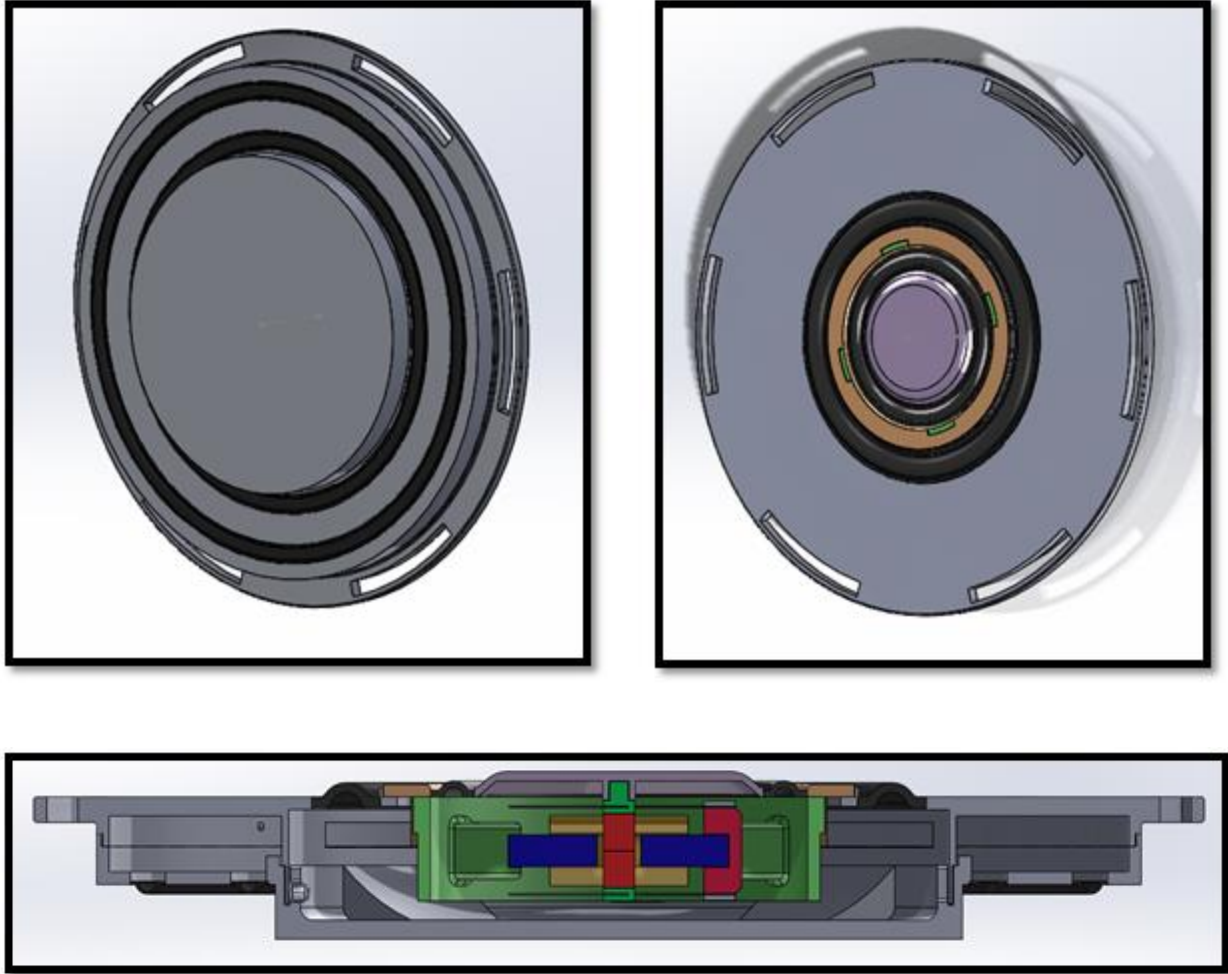

*Figure 62: Moving Magnet Final Design 1 Version 4 CAD model*

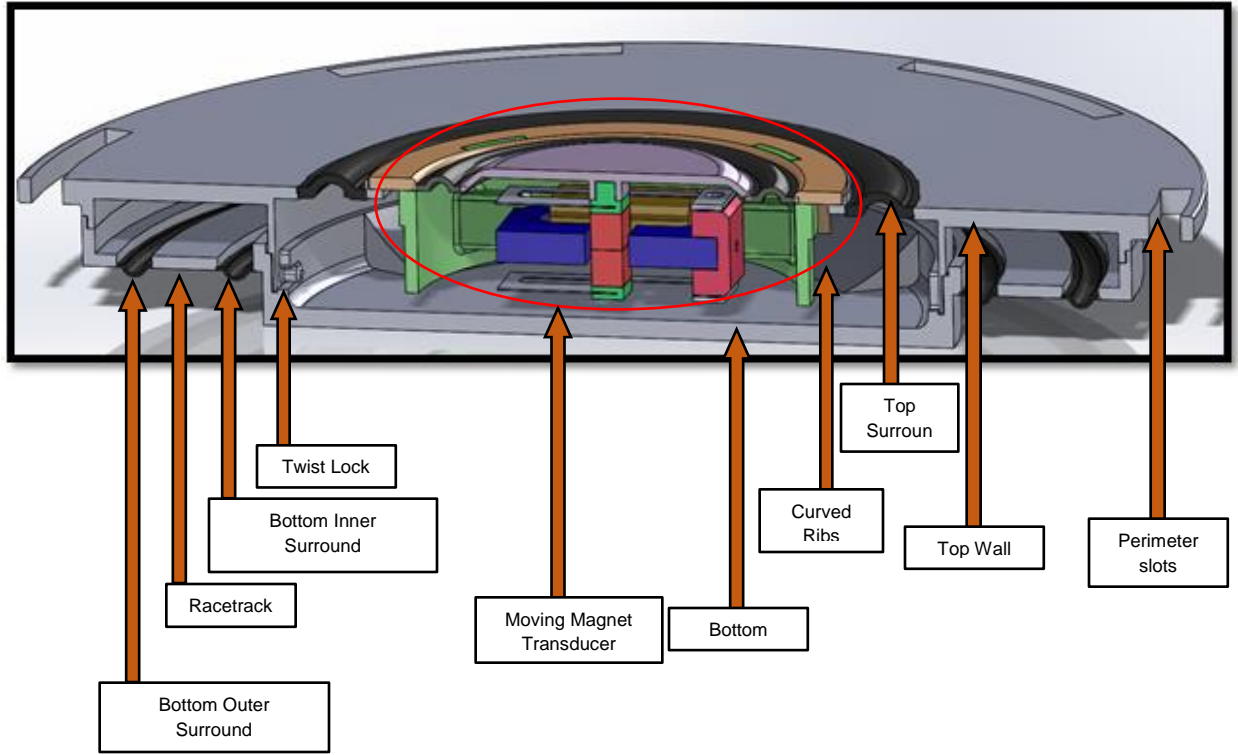

Figure 63: Moving Magnet Final Design 1 Version 4 cross section view



1) Moving Magnet Transducer



2) Double Passive Radiator Box

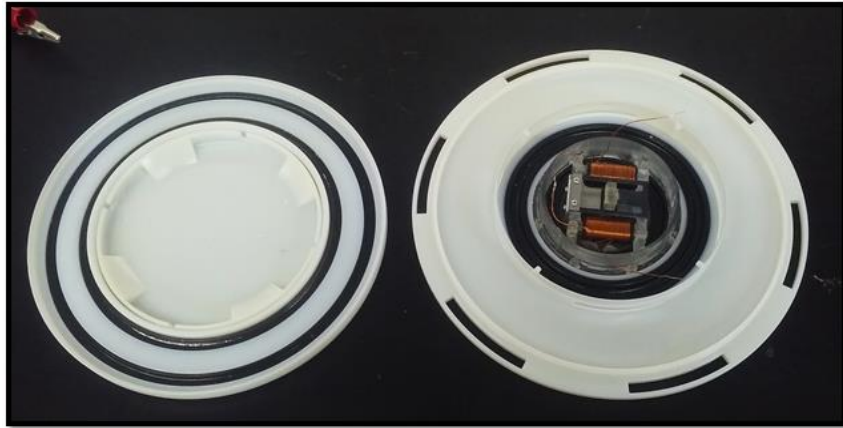

3) Seal Transducer in top half of the box and connect

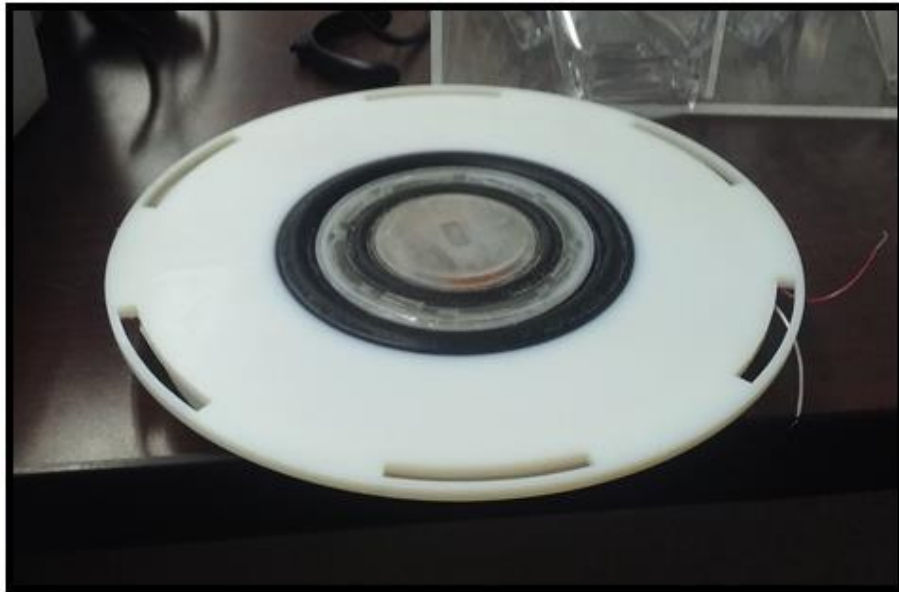

4) Seal Top and bottom halves of speaker box

*Figure 64: Assembly steps of the final Moving Magnet Box Design*

Table 10: Moving Magnet Box Design 1 Version 4 Specifications

<b><u>Moving Magnet Box Design 1 Version 4 Specifications</u></b>	
Objet Materials	Rigid: VeroWhite; Flexible: TengoBlackPlus
Overall Thickness	22.39 mm (0.881 inches)
Overall Diameter	186.16 mm
Intended Transducer	Moving Magnet
Top Surround Thickness	1.75 mm (flat) & 1.5mm (curved)
Bottom Surrounds Thickness	0.5 mm
Racetrack Thickness / weight	2 mm / 8.75g
Bottom Wall Thickness	3 mm
Top Wall Thickness	3 mm
Approx. Air Volume	15.38 cubic Inches
3d Printed	Yes (x6)
Resonant Frequency	~85 - 90 Hz
Additional Features	<ul style="list-style-type: none"> <li>● Thicker top and bottom walls</li> <li>● Shortened ribs</li> <li>●</li> </ul>



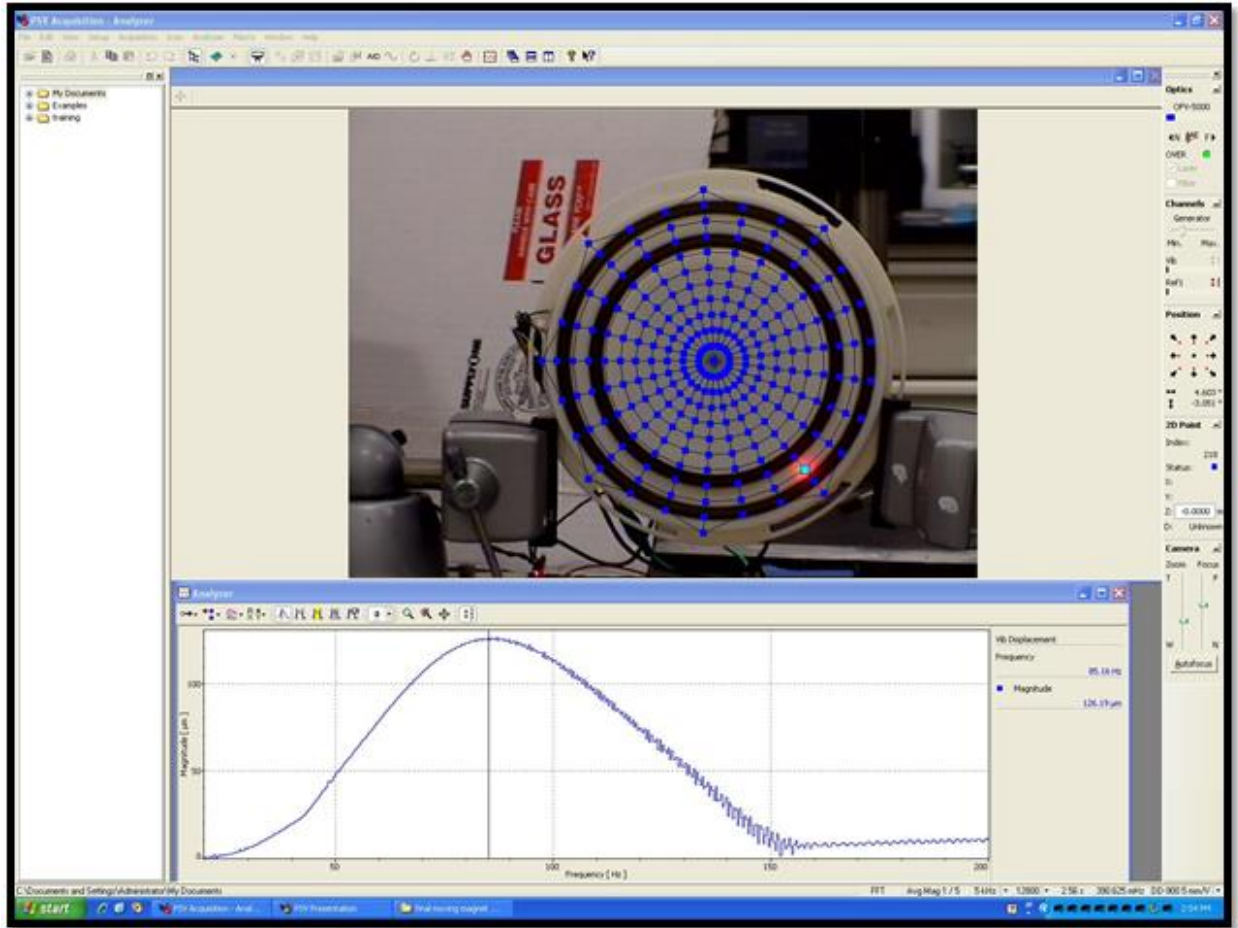

Figure 65: Moving Magnet Box Final Design 1 Version 4 Polytec Scanning Vibrometer scan with resonant frequency at ~85 Hz

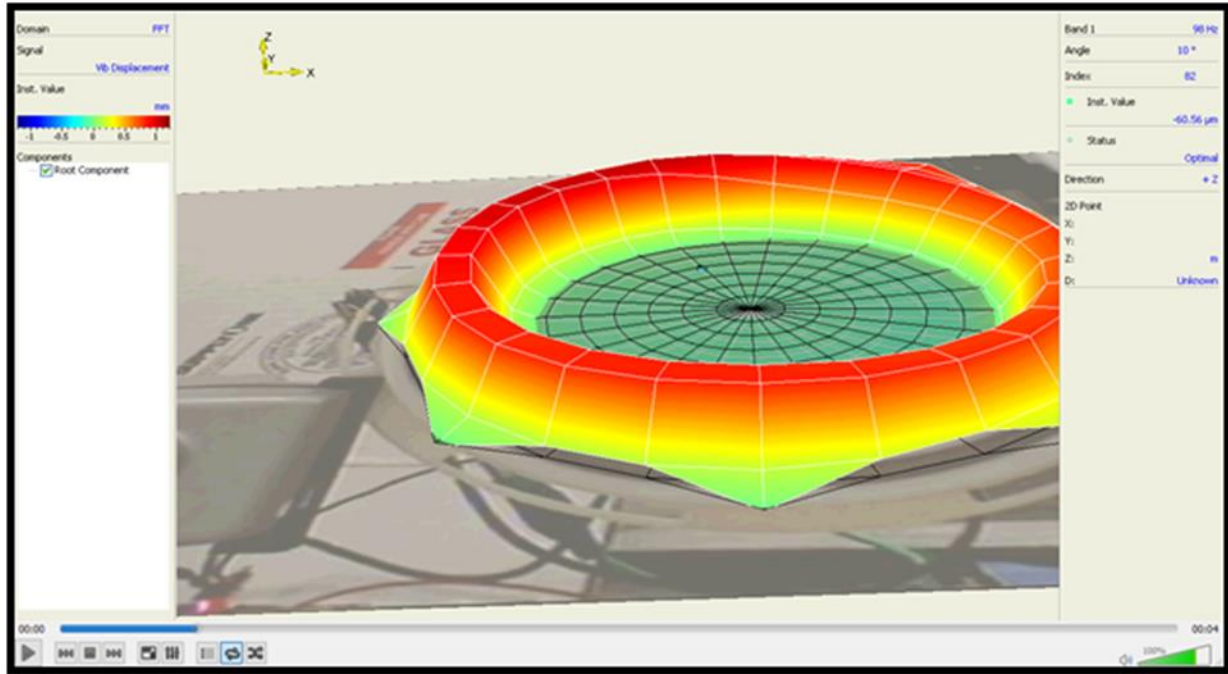

Figure 66: Moving Magnet Box Final Design 1 Version 4 Polytec Scanning Vibrometer scan slow motion video screen shot of bottom passive radiator at 85 Hz

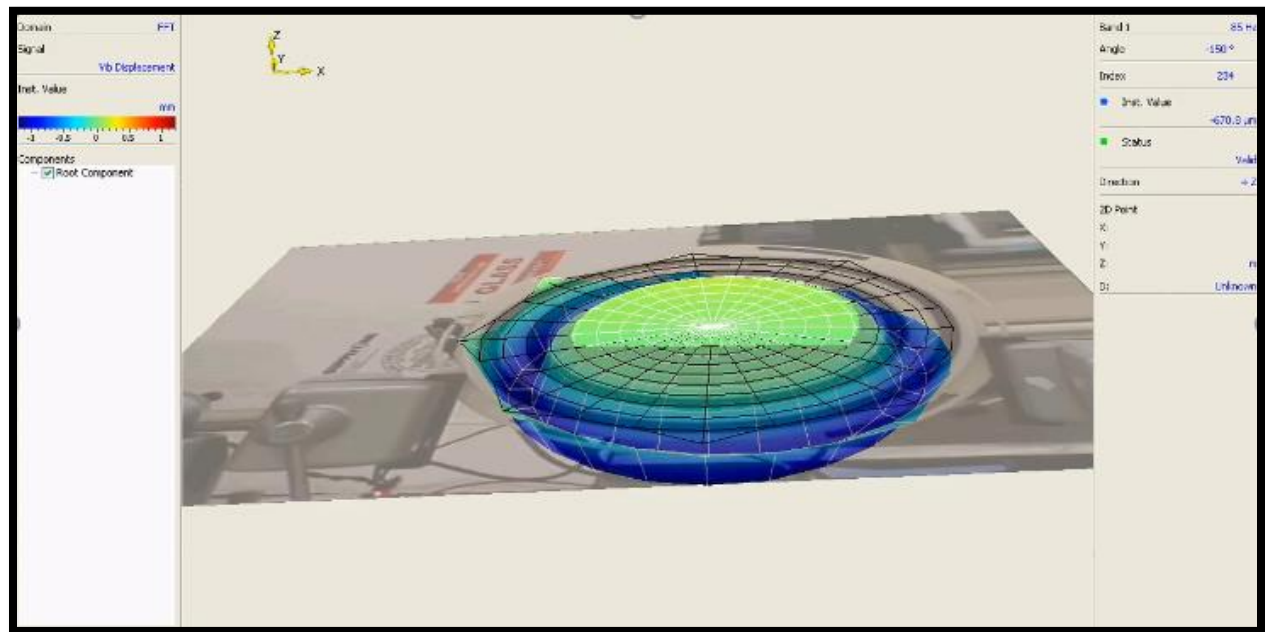

Figure 67: Moving Magnet Box Final Design 1 Version 4 Polytec Scanning Vibrometer scan slow motion video screen shot of bottom passive radiator at 85 Hz

## 4.5 Moving Coil Transducer Flexible Housing Incorporation

Since it was decided that 2 moving coil transducers designed by a separate sub-team would be the speakers in the overall frame that are able to rotate mechanically in order to assist with steering sound, a flexible housing design was needed. A housing was first designed to incorporate a Daffodil transducer and later a moving coil transducer to be used in the final wall-mounted home speaker system.

### 4.5.1 Moving Coil Flexible Housing Design 1

Before 3d printing the flexible housing for the moving coil transducer, it was decided to first design a similar flexible housing for the Daffodil transducer. This would allow more time for the Moving Coil team to further develop their transducer and our team to assess if there are any design changes that need to be made. When designing this prototype the main difference from the housing designed for the moving coil was the thickness, since the Daffodil transducer was thicker than the Moving Coil transducer. The approximate thickness of this design is 21.59 mm and its approximate diameter is 141.34 mm. For this design the flexible TangoBlackPlus sections were 1.75 mm thick to be able to assist the support rod with supporting the weight of the Daffodil while still being able to be flexible enough to be turned with a motor system. Figure 68 shows the CAD model of this design and Figure 69 shows its labeled cross section. Table 11 lists this design's specifications. Figure 70 shows the assembly of this design.

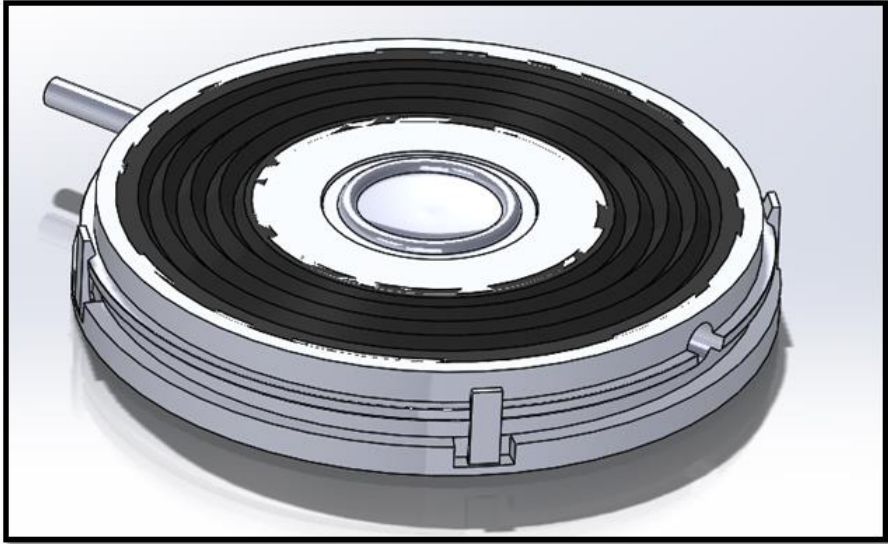

Figure 68: Moving Coil Flexible Housing Design 1 CAD model

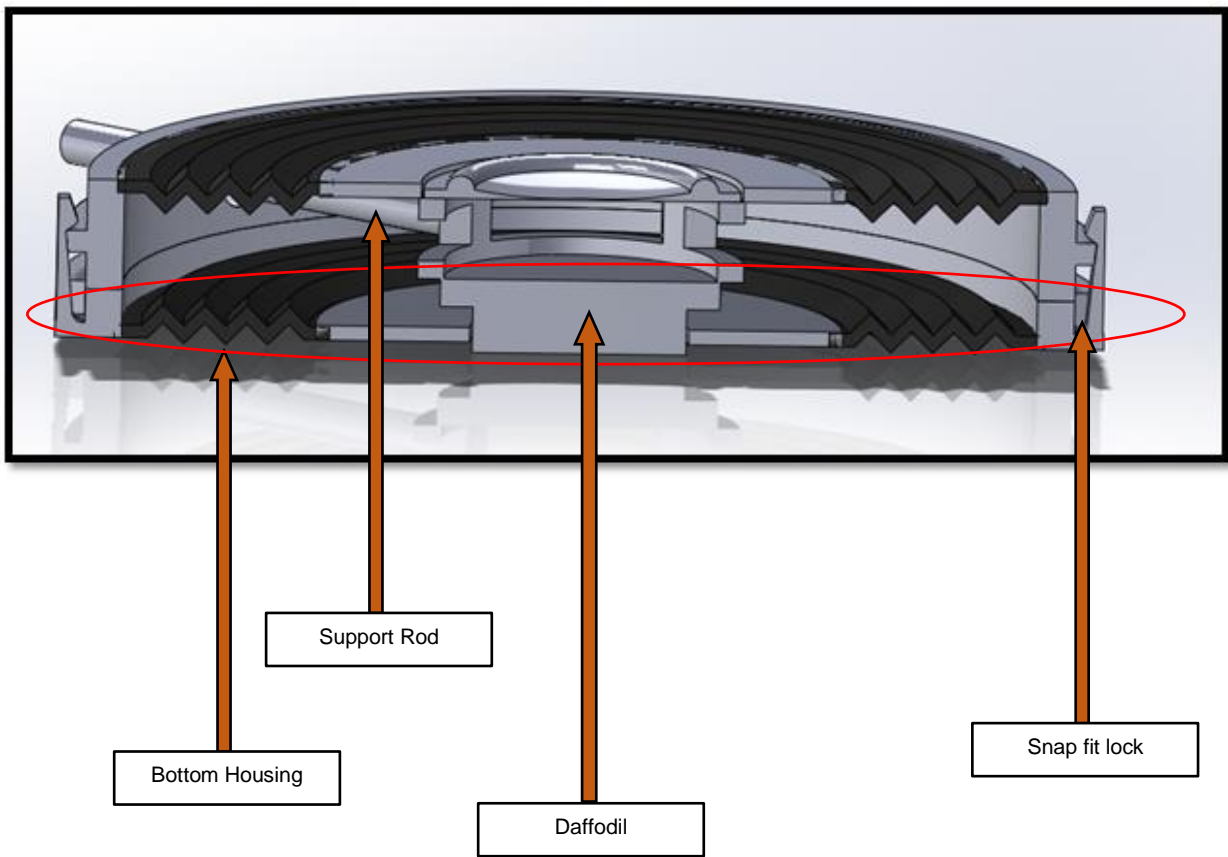
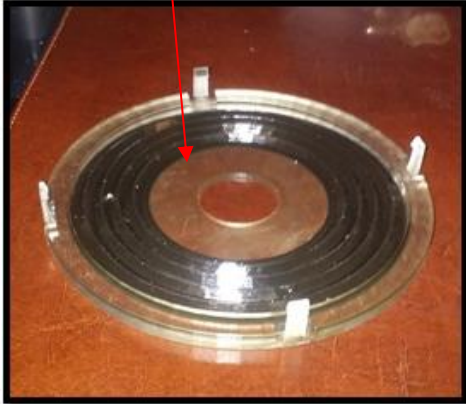

Figure 69: Moving Coil Flexible Housing Design 1 cross section

Table 11: Moving Coil Flexible Housing Design 1 Specifications

<b><u>Moving Coil Flexible Housing Design 1</u></b>	
Overall Thickness	21.59 mm (0.85 inches)
Overall Diameter	141.34 mm
Intended Transducer	Daffodil
Flexible material thickness	1.75 mm
3d Printed	Yes
Additional Features	<ul style="list-style-type: none"><li>• Snap-fit lock</li></ul>

Bottom Half



Top Half with Daffodil Transducer



Back of assembled housing



Front of assembled housing

Figure 70: Moving Coil Flexible Housing Design 3D printed prototype assembly

## 4.5.2 Moving Coil Flexible Housing Design 2

### Moving Coil Flexible Housing Design 2 Version 1

Design 2 Version 1 of the flexible housing design had several changes. This design was to house the moving coil transducer. As a result it was thinner than the previous design. Figure 71 shows this design and Figure 72 shows its cross section. Table 12 lists this design's specifications.

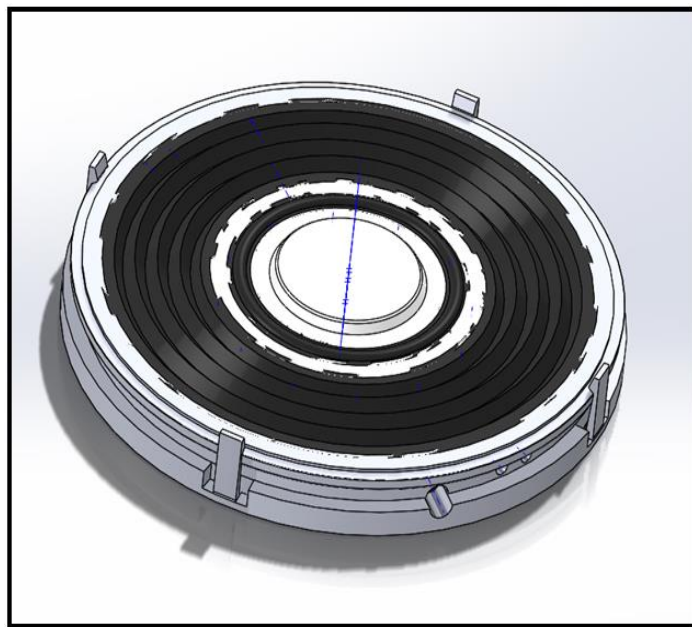

*Figure 71: Moving Coil Flexible Housing Design 2 Version 1 CAD model*

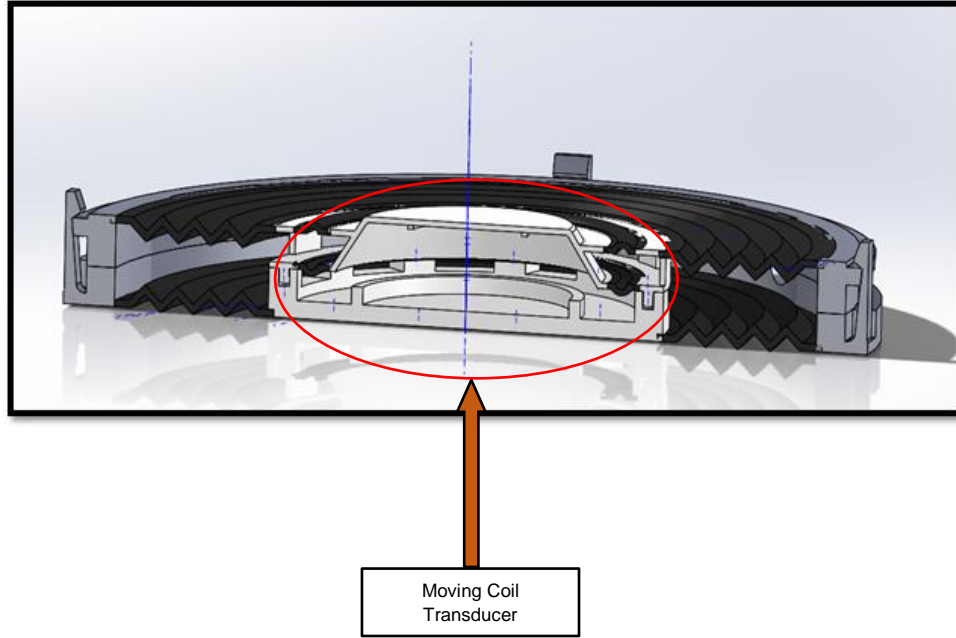

Figure 72: Moving Coil Flexible Housing Design 2 Version 1 cross section

Table 12: Moving Coil Flexible Housing Design 2 Version 1 Specifications

<b><u>Moving Coil Flexible Housing Design 2 Version 1</u></b>	
Overall Thickness	19mm (0.748 inches)
Overall Diameter	141.34mm
Intended Transducer	Moving Coil
Flexible material thickness	1.25mm
3d Printed	No
Additional Features	<ul style="list-style-type: none"> <li>● Snap-fit Lock</li> <li>● “Zig-Zag” flexible support</li> <li>● Added holes for wires</li> </ul>

### Moving Coil Flexible Housing Design 2 Version 2

This version was the final version used in the overall wall-mounted home speaker system and had several design changes from the previous version. First the bottom half of the assembly was removed and



a support was added to the top half. This allowed for less parts that needed to be printed. Additionally, a hollow rod was added to the prototype so that the motor could fit into it and rotate the moving coil transducer. Figure 73 and Figure 74 show the CAD models of this design.

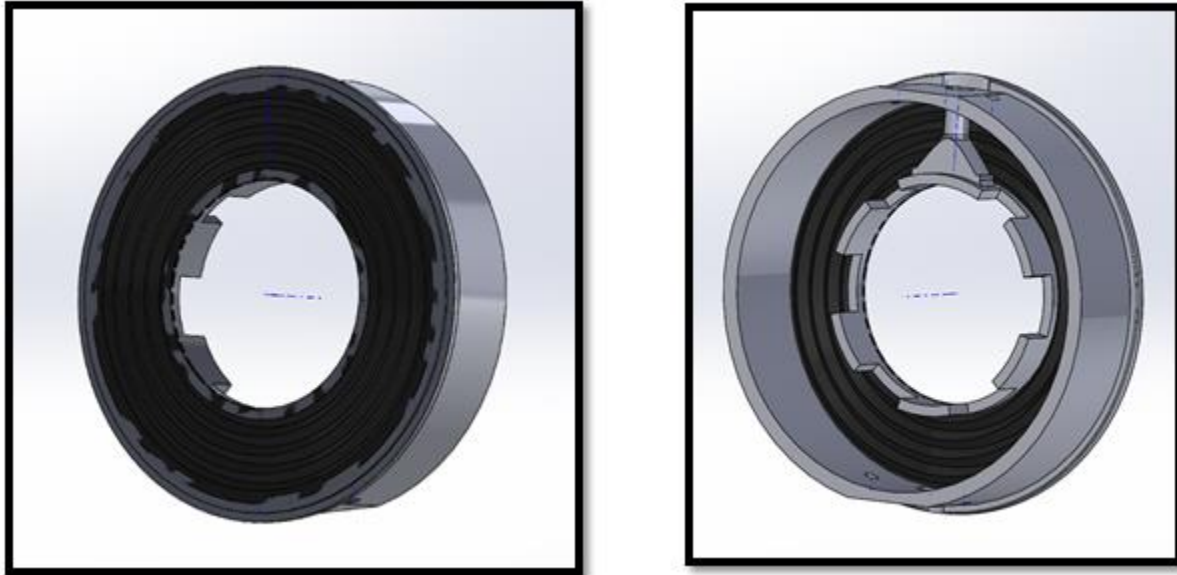

*Figure 73: Moving Coil Flexible Housing Design 2 Version 2 CAD model*

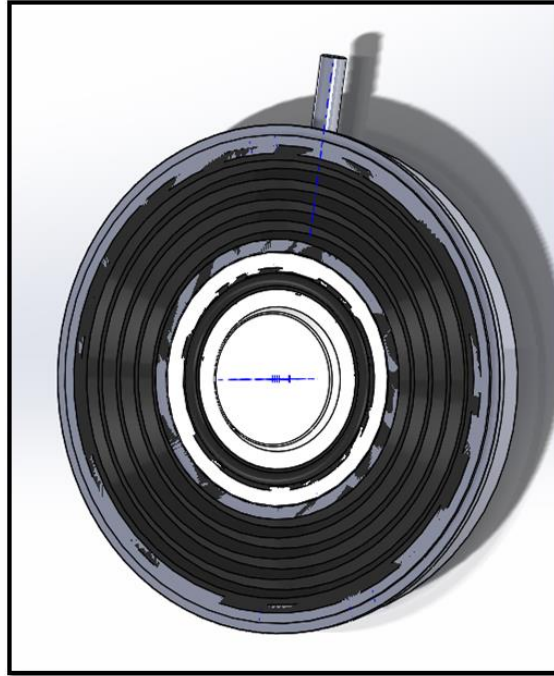
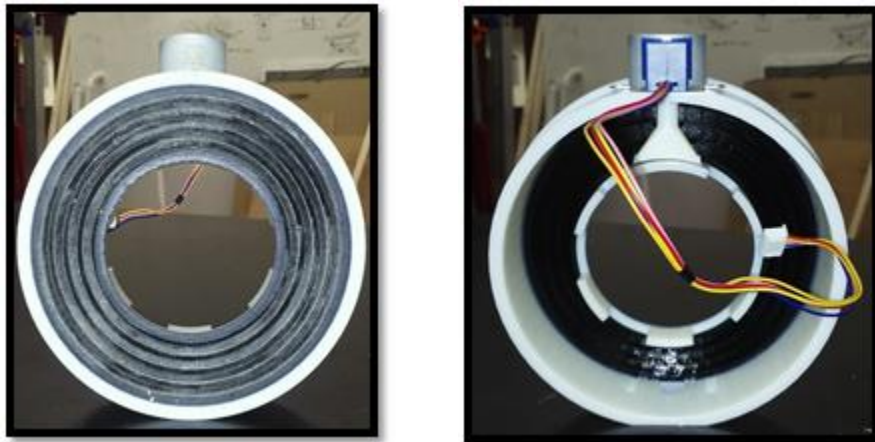

Figure 74: Moving Coil Flexible Housing Design 2 Version 2 CAD model with moving coil transducer

Table 13: Moving Coil Flexible Housing Design 2 Version 2 Specifications

<b><u>Moving Coil Flexible Housing Design 2 Version 2</u></b>	
Overall Thickness	32.7mm (1.287 inches)
Overall Diameter	138.95mm
Intended Transducer	Moving Coil
Flexible material thickness	1.26mm
3d Printed	Yes
Additional Features	<ul style="list-style-type: none"> <li>● Removed Bottom Assembly</li> <li>● Added transducer support</li> <li>● Added support for the rod</li> </ul>

Once the flexible housing was 3d printed and the moving coil transducers were fabricated, the housings, motors, and transducers, were assembled. Figure 75 shows the assembled flexible housing and motor and Figure 76 shows the assembled flexible housing with the motor and moving coil transducer.



*Figure 75: Final 3D printed Moving Coil Flexible Housing with motor attached*

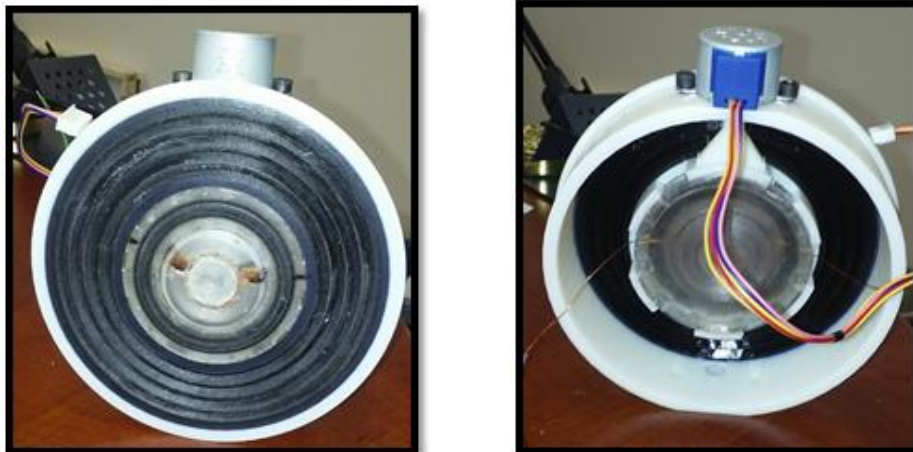

*Figure 76: Final 3D printed Moving Coil Flexible Housing with motor attached and with moving coil transducer*

## 4.6 Overall Low Profile Home Speaker System Design

Our team was tasked with starting the overall speaker system frame design to incorporate all of the sub-teams' work into one speaker system. The following sections show the initial designs for the

frame. The rest of the frame designing and fabricating process was then transferred to the resonant exciter sub-team.

## 4.6.1 Speaker System Design 1

### Speaker System Design 1 Version 1

Speaker System Design 1 Version 1 (SSD1:V1), was the first attempted design to incorporate multiple speaker boxes. This prototype was designed to fit tightly against a wall, with a thickness of 23 mm. Six separate speaker boxes incorporating the moving magnet group's transducer would provide the lower bass frequencies, while six individual "tweeters" would provide high frequencies. These tweeters would also be from the moving magnet group, however these transducer would not be mounted in a speaker box. The wall mount would be lifted off the wall slightly, and therefore small slits would be cut into the sides of the box, to allow sound to escape the back. Cut into the back side of this wall mount were areas for individual batteries to power each speaker. The tweeters would be placed with three on the left side of the mount, and three on the right side of the mount. The three speakers on either side of the mount would all be connected to a rack and pinion system, allowing the tweeters to rotate from side to side. The rack and pinion would be driven by a small step motor, which would be controlled by a remote. Spaces were provided in the back for the later incorporation of sound steering by means of an infrared sensor. Figure 77 and Figure 78 show CAD models of this design.

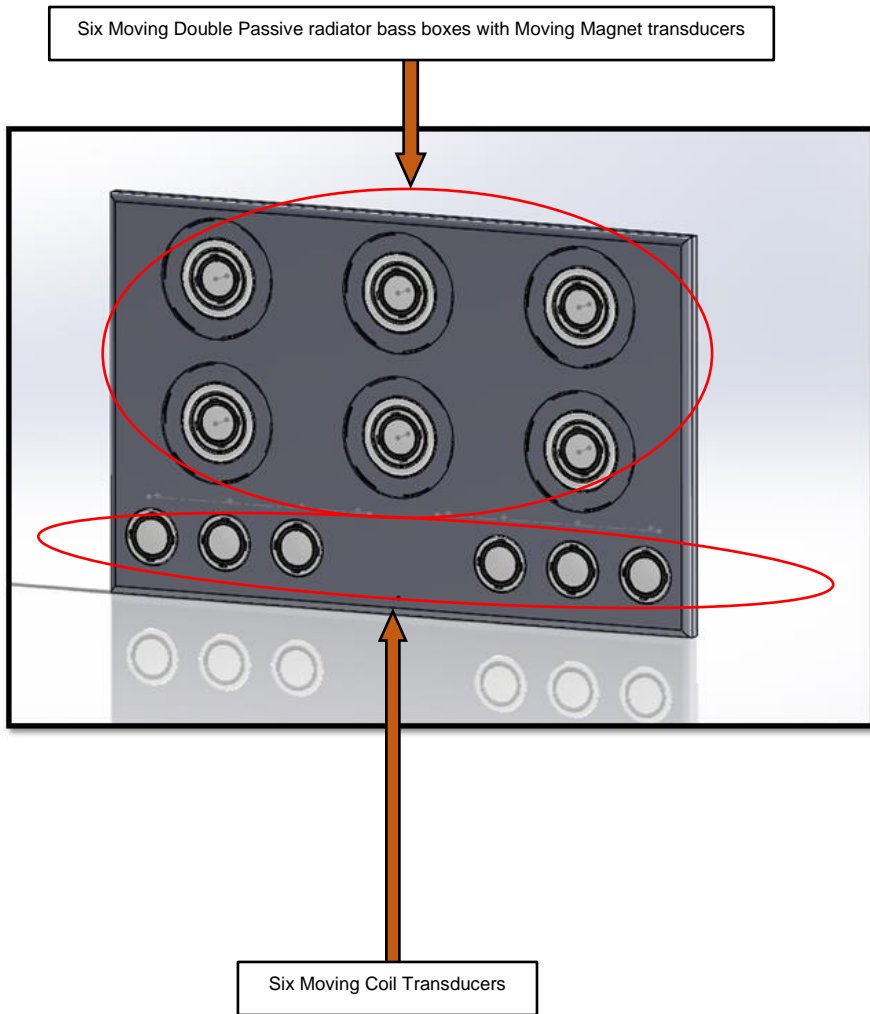
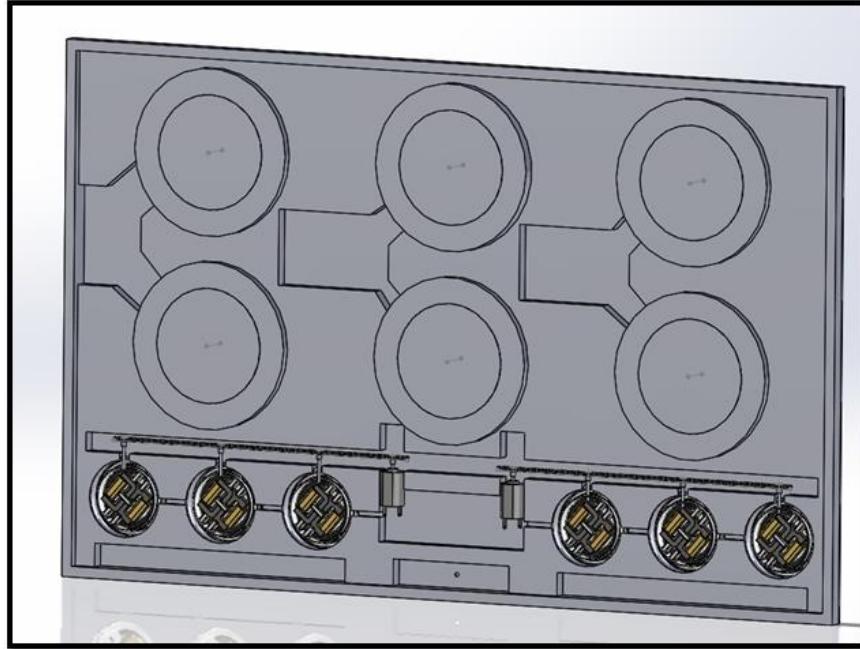

Figure 77: Speaker System Design 1 Version 1 CAD mode front



*Figure 78: Speaker System Design 1 Version 1 CAD model back*

## Speaker System Design 1 Version 2

Speaker System Design 1 Version 2 (SSD1:V2), is very similar to SSD1:V1. In this prototype, the moving magnet transducers, mounted in our speaker box design, will produce the mid to low range frequencies, roughly 70HZ to 150HZ. In this prototype only four moving magnet transducers will be used, compared to the six previously used. Planar coil transducers will be used again for mid to high range frequencies, keeping six transducers along the bottom. The two main differences between Version 1 and Version 2, will be the addition of the resonant exciter's work, as well as the method for sound steering. In Figure 79 the large rectangular hole will be used to mount the resonant exciter's work. This addition will cover the low range frequencies, from 30Hz to 70Hz. The second biggest change in Version 1 to Version 2, is the method of moving the "tweeters". In previous designs, a rack and pinion system had been used to rotate the tweeters. In Version 2 a step motor will again be utilized, however, it will be driving a pulley system. This pulley system will be responsible for rotating the six tweeters. Two possible configurations allow for different possibilities of rotation. If two separate pulleys are used, then the tweeters can be turned in a set of three, allowing some to turn left, while others turn right. Lastly these

tweeters will be encased in a flexible membrane, allowing for rotation, but not allowing for sound produced from the rear to phase out sound produced in the front. This effect will increase the sound quality delivered by the tweeters. The overall thickness of this frame design is 21 mm but may need to be adjusted to incorporate the motors that will be rotating the tweeters. Figure 79 shows this frame design and Figure 80 shows its cross section.

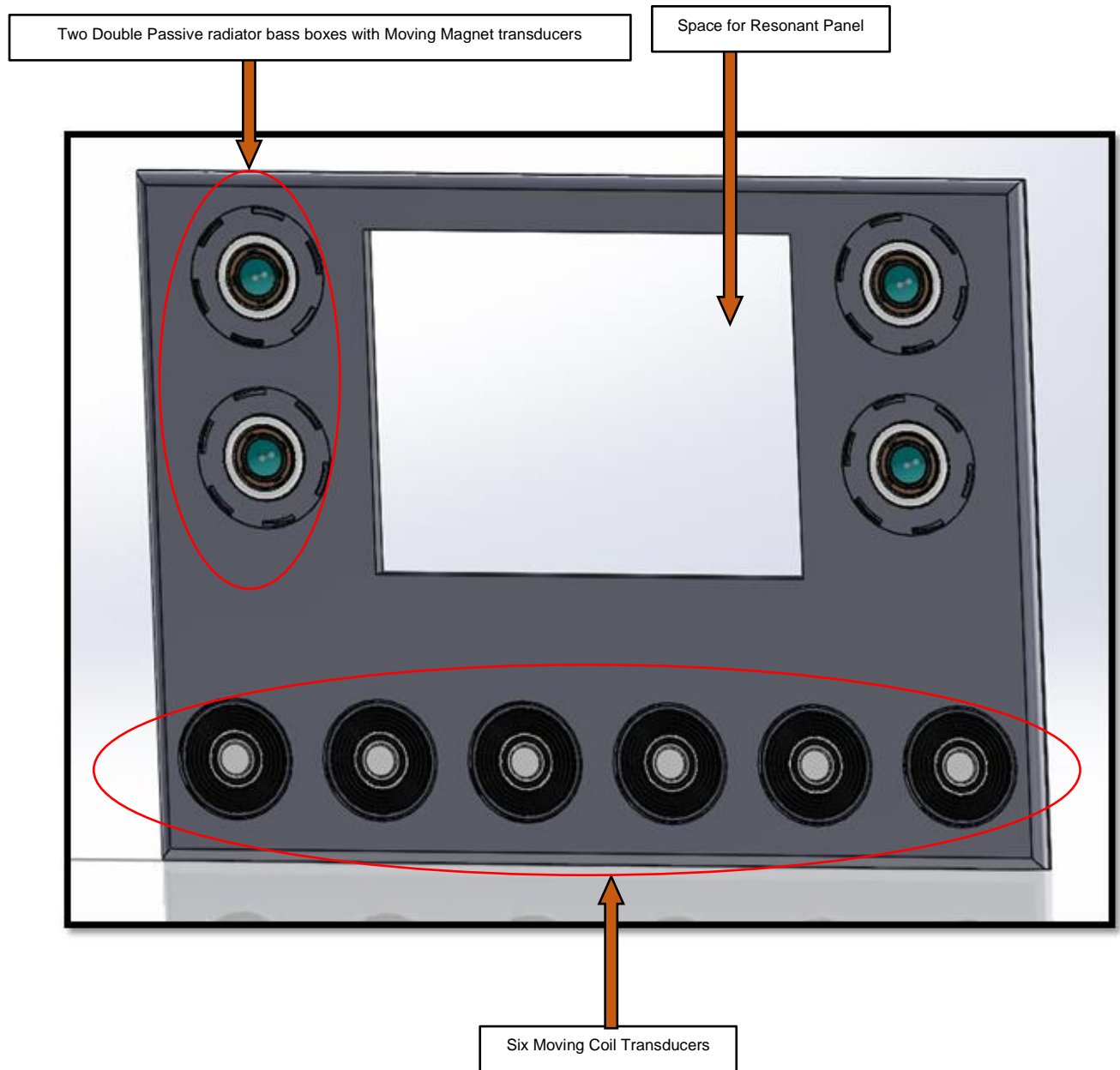

Figure 79: Speaker System Design 1 Version 2 CAD model



*Figure 80: Speaker System Design 1 Version 2 cross section*

#### 4.6.2 Speaker System Design 2

At this point the responsibility of manufacturing the overall frame was transferred to the resonant exciter team as they had more available resources and time to continue to build the frame. The final speaker system design was similar to our speaker system design 1 version 2 except that it had 6 moving magnet speaker, 8 moving coil speaker, and the bass panel with 3 additional moving magnet transducers. The bass panel was to produce frequencies between 40 and 80 Hz, the 6 moving magnet transducers that are part of the double passive radiator bass boxes were to produce frequencies between 80 and 200 Hz, and the 8 moving coil transducers were to produce frequencies above 200 Hz. Additionally, 6 of the moving coil transducers were to have the ability to steer without moving by using sensors and the remaining 2 moving coil transducers were to assist with the sound steering by having the ability to rotate mechanically also using the sensors. The five sensors were incorporated at the top center of the final speaker system prototype. Figure 81 and Figure 82 show the front and back of the final fabricated low profile home speaker system (before electrical wiring).



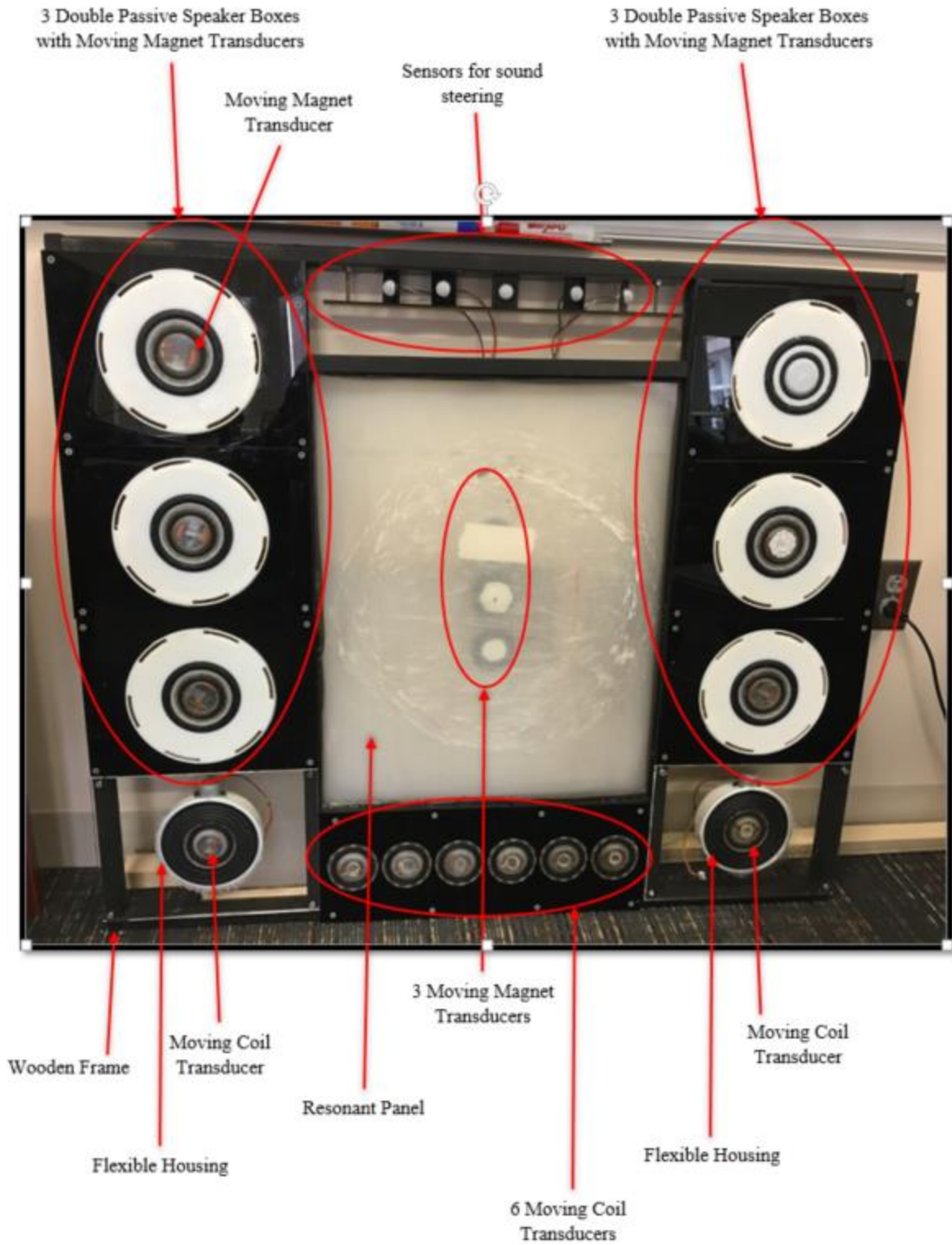

Figure 81: Low Profile Home Speaker System Final Prototype (front)



*Figure 82: Low Profile Home Speaker System Final Prototype (back)*

## Chapter 5: Recommendations

In future projects we recommend improving the force-balanced, raised, sealed double passive radiator design that incorporates the moving magnet transducer. This could include experimenting with different materials for both the flexible and rigid components which could help to reduce damping effects and other undesired effects.

In addition, we recommend that students completing a speaker project use Simscape as their software program to project resonant frequency responses. We suggest reading material about Simscape, completing tutorials, and setting up a means of communication with an employee of MathWorks who can aid in completing the models. As stated in the results section, the final model's linear analysis did not fully match with the outcome from the Polytec Scanning Vibrometer testing. Although the model was believed to be built correctly, more work must be done to get an accurate linear analysis result.

During assembly of the prototype the team recommends to be careful not to break the prototype, ensure that the wires have clearance to come out of the box, and to ensure that the box is air-tight. Our team used silicone to allow the boxes to be air-tight but there may be a better alternative. It was also important to allow enough clearance between the bottom of the transducer and the bottom wall of the box.

Another recommendation is to test the Instron for accuracy before using it. Our team found that the calculated weight displayed by the Instron was off by a factor of 1.39. This led to the team having to adjust the data gathered by the Instron by the scale factor described in Appendix C.

When using the Polytec Scanning Vibrometer the team recommends ensuring that the box being tested is securely clamped and fixed, that the Scanning Vibrometer settings are correct, that the box is being scanned at the desired location and frequency range, and that the box is air-tight.

Finally, the team recommends reading/researching all five reports by the five sub-teams and the report by the 2016/2017 Major Qualifying Project: *The Synthesis and Design of a Small Speaker System*. By referencing these reports along with additional research, future projects will be able to more quickly enter the design phase with a higher chance for success.

## Chapter 6: Conclusions

Initially, the team had limited knowledge about acoustics and the fabrication process of speaker. After researching and writing reports from August 2017 to October 2017, the team was able to gain a significant amount of knowledge relating to speakers and how their boxes/enclosures can impact their sound output.

The team then used that knowledge to design, simulate, analyze, 3D print, test, and improve the speaker boxes. This process was repeated several times for a variety of transducers. Throughout the design process the team was able to learn how to use ANSYS, an Instron Microtester, a Polytec Scanning Vibrometer, PSpice, and Simscape. All of these tools helped with speeding up the design process and improving the quality of the designs. Toward the end of March 2018, the team had developed a final design to incorporate the moving magnet transducer designed by one of the other sub-teams. There were 6 of these boxes 3D printed for the low profile home speaker system. There were 2 mechanically rotating housings 3D printed to incorporate two moving coil transducers. Once the other teams had their final prototypes, all of the speakers and hardware were arranged in a low profile frame. Then the electrical team, with help from other members, wired, soldered, and incorporated the sound steering and sound filters for the final speaker system.

The five sub-teams then presented their results and the low profile home speaker system to Worcester Polytechnic Institute facility, colleagues, and alumni at WPI's annual project presentation day. The Speaker System is shown in Figure 83. Following this presentation, all sub-teams then presented their results and speaker system to Bose Corporation. Our sub-team's final presentation is shown in Appendix K and our final poster is shown in Appendix L.



*Figure 83: Final Low Profile Home Speaker System Prototype*

## 6.1 Limitations of the Project

There were many limitations encountered during the teams' project. One of the issues realized early on in the project was communication. The teams found that it was nearly impossible to find a time where all 17 members could meet. As a result, weekly, hour long meetings were created at times where the most people could attend. Each team had to have at least one member present to give updates about their team's progress. These meetings also served to make decisions about future plans, goals, and recommendations.

Other limitations relating to our specific sub-team include material selection, software/hardware expertise, and time management. While the team was very familiar with SolidWorks other software programs including ANSYS, PSpice, and Simscape had to be learned. ANSYS was learned by taking

classes that provided experience with the program, by watching online videos relating to structural aspects, and by referring to colleagues. PSpice, while used for initial designs, was found to offer limited capabilities for what the team needed it for. As a result, the software was shifted from PSpice to Simscape. Simscape offered greater capabilities and was found to be widely used by Bose Corporation and other companies. Simscape was learned by watching online videos, referring to our project advisor, and by contacting MathWorks through several phone calls/video chats for assistance. While the team was able to get working model, many improvements could be made and more knowledge can be gained.

3D printing, while a great method for prototyping and redesigning, did also have limitations. The Objet 260 Connex owned and operated by the ARC of Worcester Polytechnic Institute was chosen as the 3D printer to use because it could print both flexible and rigid materials simultaneously. However, the material selection was limited. For example, the flexible material used was not the ideal material to use because after being deformed it took a longer time to return to its original shape. This may have affected our results and could have been improved if using a different material. Also, since the 3D printer was operated in WPI's Rapid Prototyping Laboratory, time to print had to be allowed as a result of many projects submitting printing requests.

Finally, time management was also a limitation. Since the final transducers intended to be incorporated into our speaker box was not finalized until March of 2018, our team had to design the boxes with the Daffodil transducer. While this was able to give us insight into what had to be incorporated into our final design, our team was given limited time to design and test the final version of our speaker box for the moving coil transducer. Time management also limited the finalization of the overall low profile home speaker system. Since all final speaker prototypes and frame were not finished until early April 2018, this left the electrical team with limited time to incorporate their sound steering and sound filtering systems. However, with the help from all 17 team members, a final working prototype of the low profile home speaker system was successfully fabricated. The system, while functioning, does also offer potential for many improvements from future projects.

# References

- [1] C. Crane, "Speakers in a Nutshell," 2018. [Online]. Available:  
<http://www.centerpointaudio.com/howspeakerswork.aspx>. [Accessed March 2018].
- [2] R. H. Small, "Passve-Radiator Loudspeaker Systems, Part 1: Analysis," *Journal of the Audio Engineering Society*, vol. 22, no. 8, pp. 592-601, 1974.
- [3] J. Ahonen , "Electroacoustic modelling of the subwoofer enclosures," 2007.
- [4] R. H. Small, "Vented-box loudspeaker systems-part 2: large-signal analysis," *Journal of the Audio Engineering Society*, vol. 21, no. 6, pp. 438-444, 1973.
- [5] R. H. Small, "Passive-Radiator Loudspeaker Systems, Part 2: Synthesis," *Journal of the Audio Engineering Society*, vol. 22, no. 9, pp. 683-689, 1974.
- [6] J. Stabile, "Acoustic device with passive radiators". United States of America Patent US9571934B2, 26 March 2014.
- [7] S. McGaffigan and R. Smolenski, "The Synthesis and Design of a Small," Worcester Polytechnic Institute, Worcester, 2017.
- [8] L. L. Beranek, *Acoustics*, New York: Beranek, 1954.
- [9] "Connex3 Objet260," Stratasys, 2018. [Online]. Available: <http://www.stratasys.com/3d-printers/objet260-connex3>. [Accessed March 2018].

# Appendices

## Appendix A: Procedure for printing the combo rubber-surround/abs-cone in WPI's Rapid Prototyping Lab

1. First ensure that there is overlap with you surround and cone/wall as shown in the circled areas. In the cross section image below. We used a 0.5mm overlap. This ensures that the parts will be printed attached to each other. Here the flexible material is shown in white and the rigid material is shown in gray.

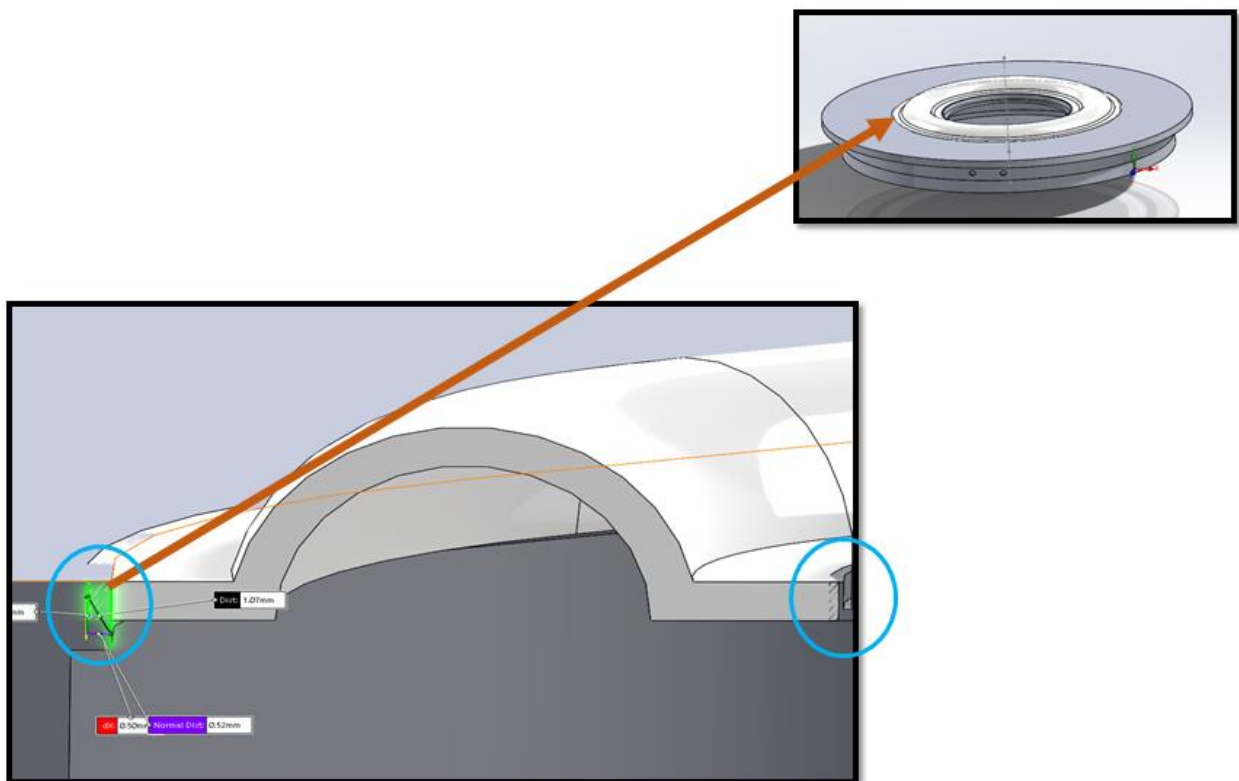

2. Save the assembly as an STL file.
  - a. Also, while saving the STL file be sure to click options and check save all components of an assembly in a single file as shown below.



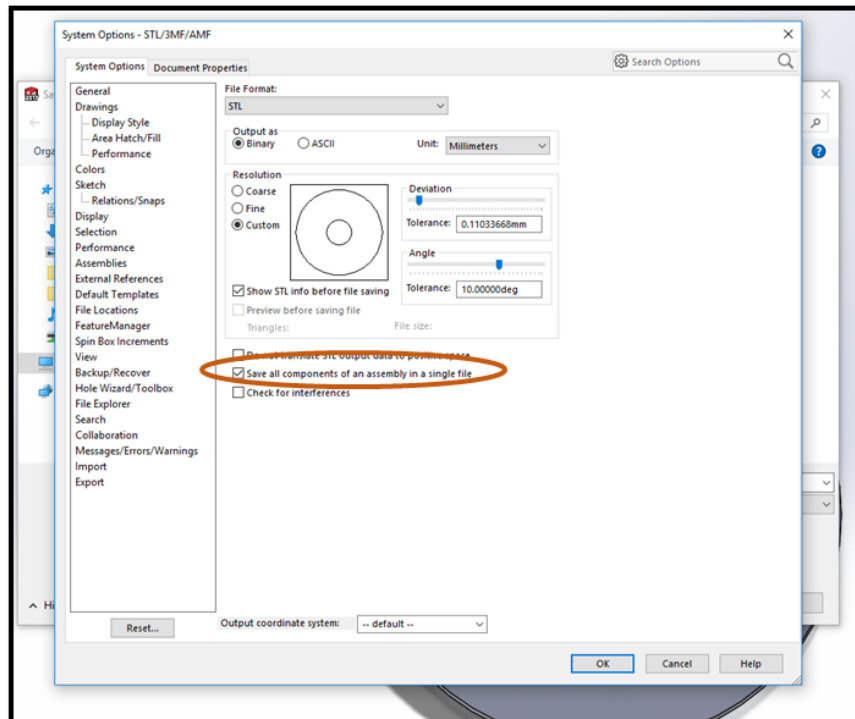
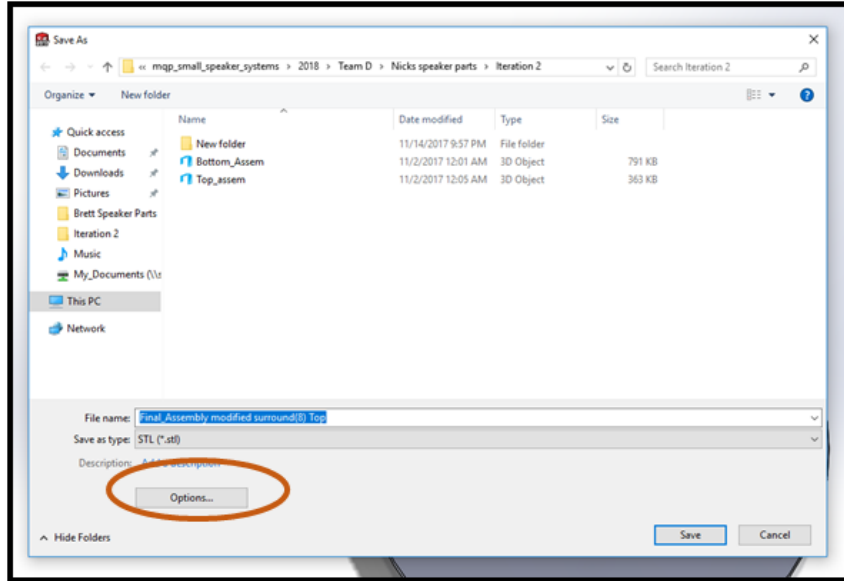

3. Navigate to the sharepoint site: <https://sharepoint.wpi.edu/academics/ME-PROTO/default.aspx>
  - a. Read the **WPI Rapid Prototyping Guidelines - 2016-08-18** before proceeding (especially the Objet 260 Connex section). This PDF can be found on this site under the “STL instructions” link in the top right corner.
  - b. Click on “Objet 260 Connex Request” (circled below).

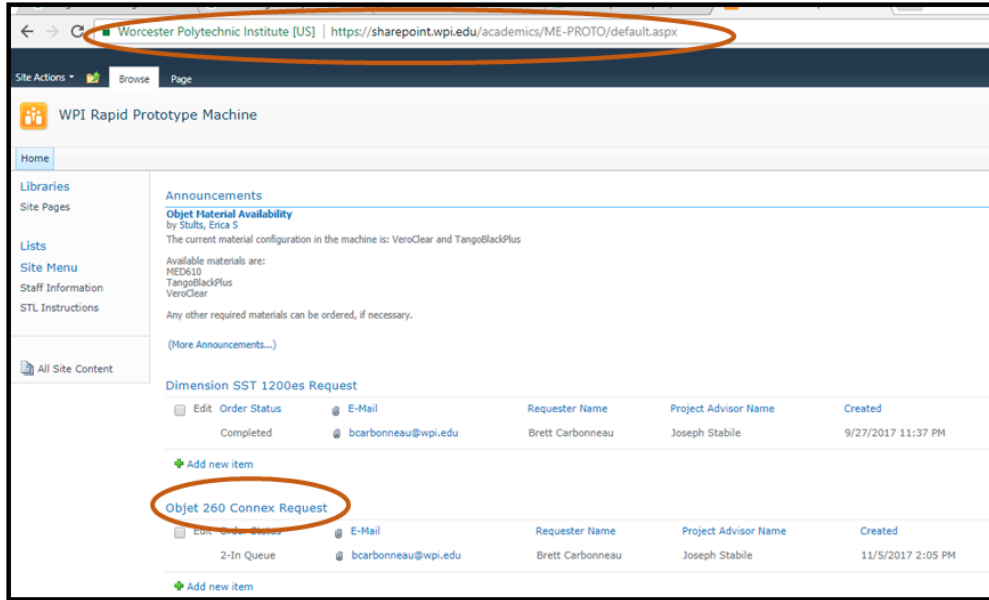

- c. Click “Add new item” and a form will appear as shown below. Fill out the fields with the red asterisks. Note: put [objet] in front of your order title; specify “multiple” for material requirements and in the description specify the CAD part names that you want to be flexible made of TengoBlackPlus and the part names you want to be rigid made of VeroClear or VeroWhite; Specify the overall assembly maximum dimensions in the x,y, and z directions. **Be sure to attach the STL file to the form by clicking the attach file button circled below.**
- d. Click Save at the bottom of the form (it is cut off from the image here). Your order is now submitted and you will get notified if there are any problems and when it is finished.

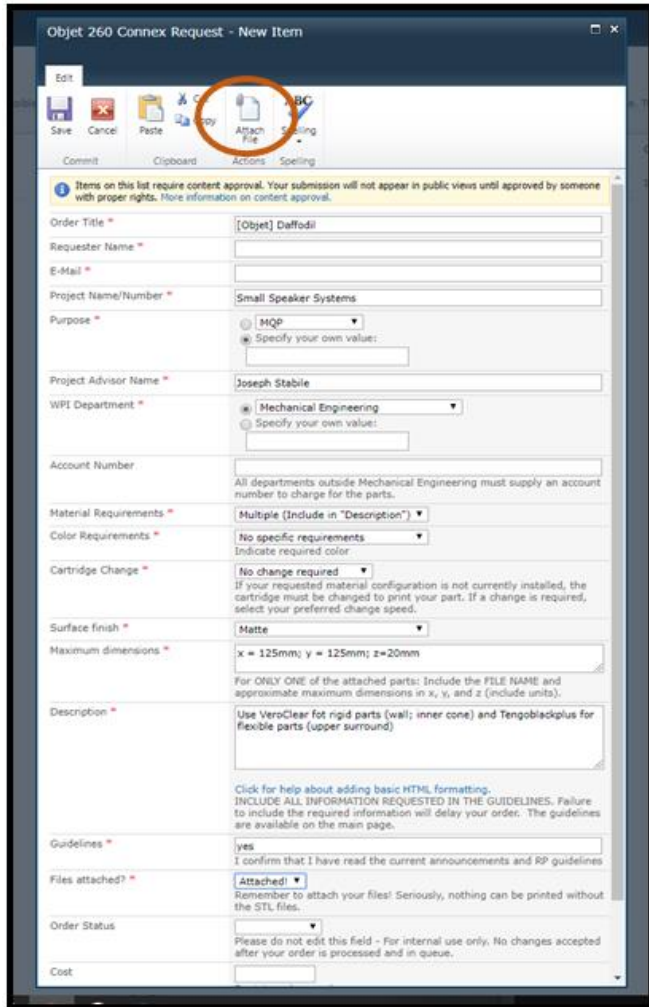

## Appendix B: Procedure for ANSYS simulation of an X weight transducer on a speaker box/passive radiator

1. Open ANSYS Workbench from the start menu
2. Click on Static Structural in the toolbox

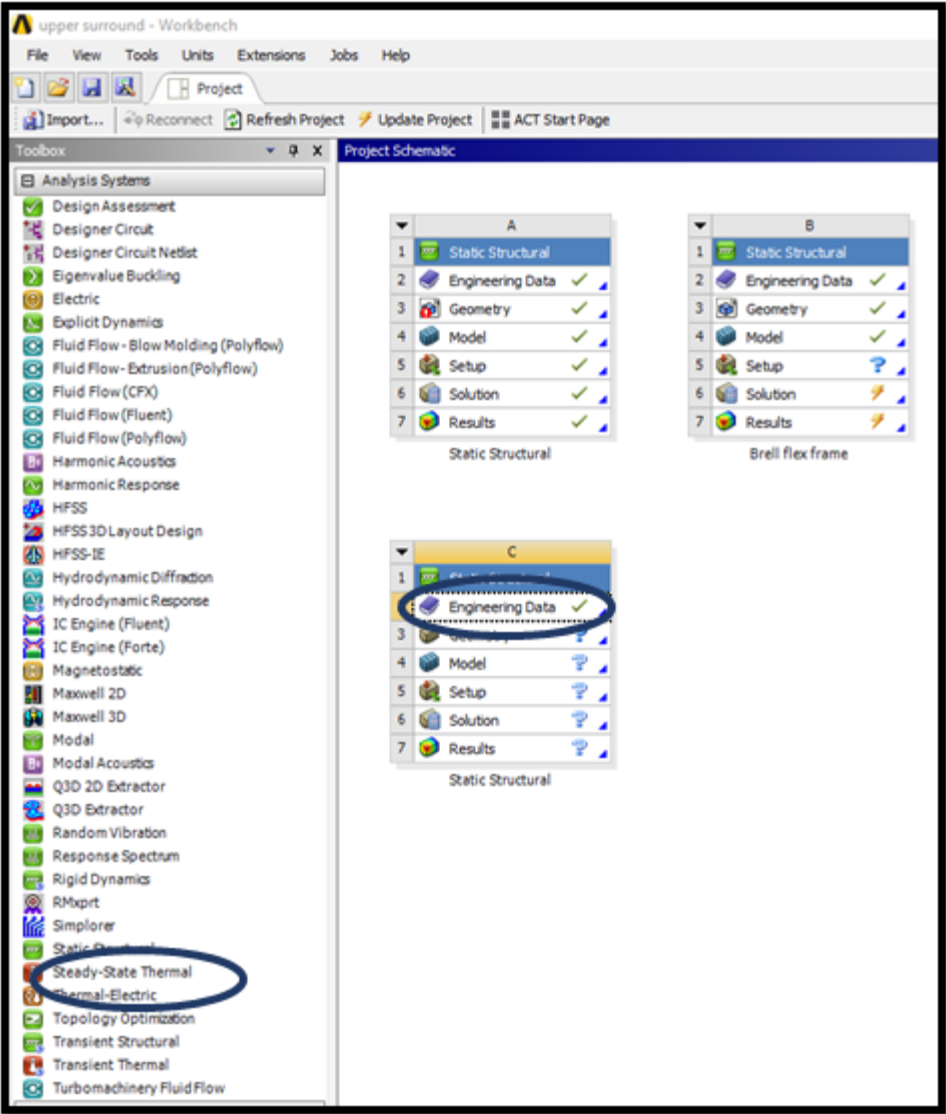

3. Double click engineering data
4. Click “Engineering data sources” (top left)
5. Double click “General materials”
6. Click the plus next to polyethylene

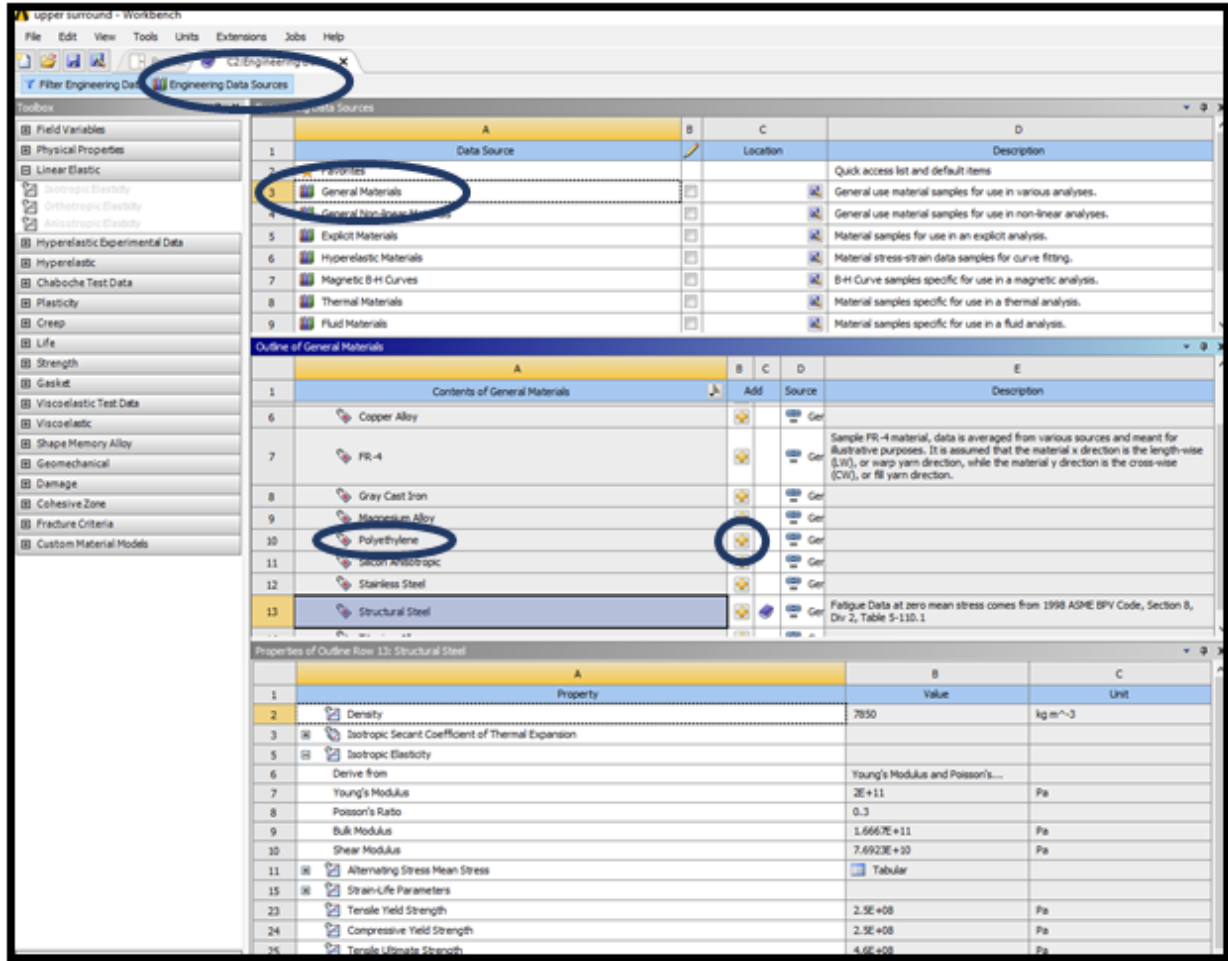

7. Click engineering data again
8. Click on polyethylene
9. And change the name to TengaBlackPlus or desired material
10. Repeat for VeroClear or desired material
11. Fill out the young's modulus & Poisson's ratio for each material
12. Ensure sure correct units

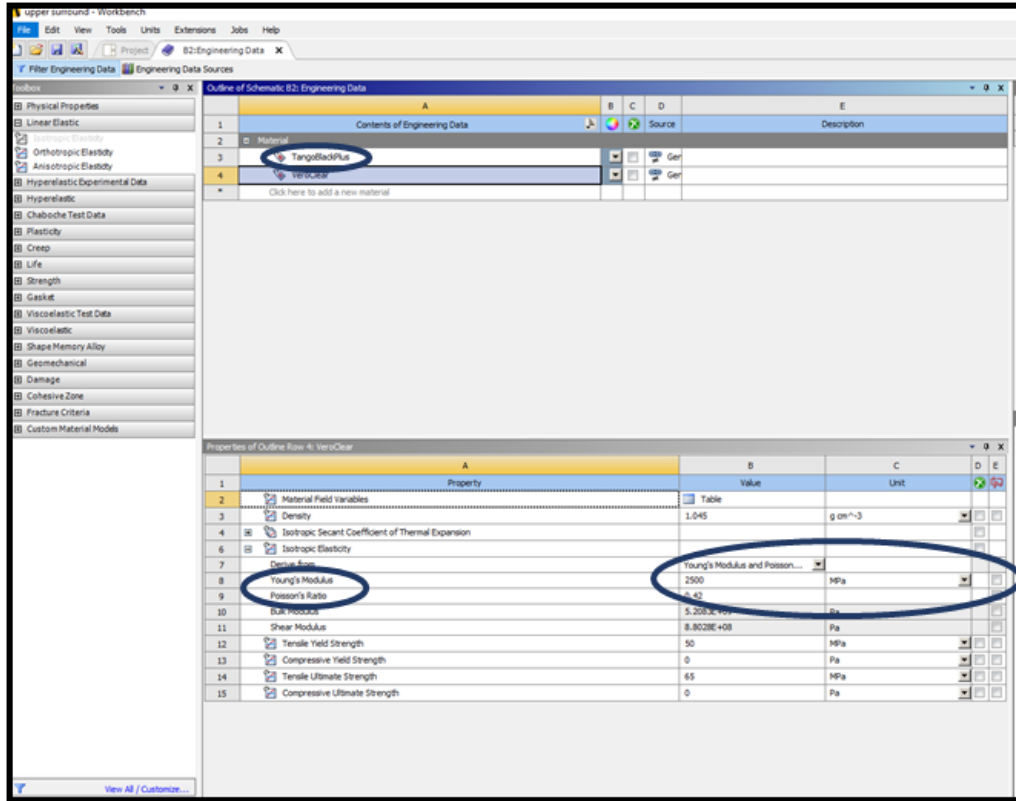

13. Import SolidWorks model/assembly by right clicking geometry, import geometry, and browse
13. Use US customary In for units
14. Double click model and ASSIGN MATERIALS TO EACH PART by clicking geometry and each part
15. Update mesh
  - a. Select: Quality>mesh metric>skewness
  - b. If there are a lot of elements above the 0.5 mark, set the size to approx. 0.075 in. to try to optimize mesh size. (mesh>sizing>element size)
16. Update mesh again
17. Check skew stat. (Should mostly be under 0.5)
18. Click static structural
  - a. Supports>fixed supports
  - b. Select fixed areas
  - c. Click apply
19. Click static structural
  - a. loads>force
  - b. Select loaded areas
  - c. Click apply
  - d. Select direction and magnitude
- 19.1 Click static structural
  - a. Click support displacement
  - b. Enter 0 in the x and z component
  - c. Select face
20. Click Solve
21. Click solution

23. Click deformation>total
24. Click solve again
25. Click deformation

Note this is a magnified scale. To see true scale click dropdown arrow

## Appendix C: Calibration of the Instron Microtester

Since our Instron data was not agreeing with our Polytec data, we performed a calibration of the Instron Microtester using quarters. First 1 quarter was weighed on the Instron. Then additional quarters were added and their weights were recorded. This data was plotted against the quarters' actual weights and resulted in a scale factor of 1.39.

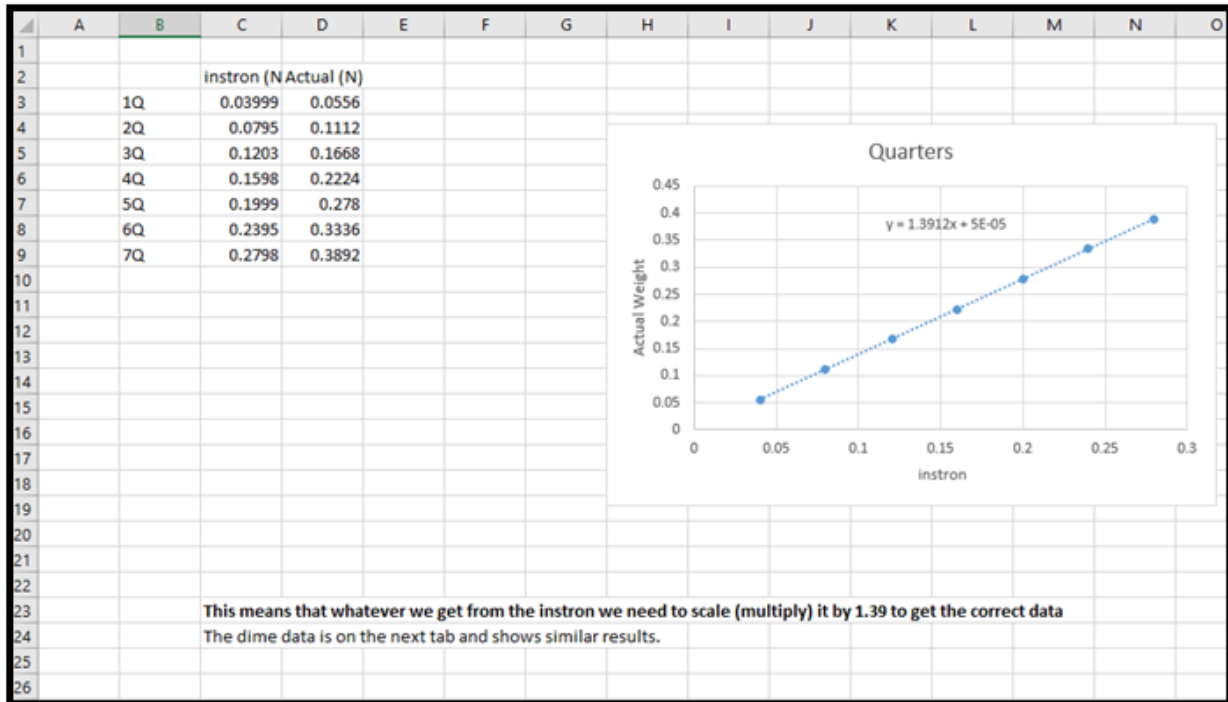

## Appendix D: Polytec Vibrometer Scans of Daffodil Box Design 1 version 1

# Prototype #1 Version #1 (back)

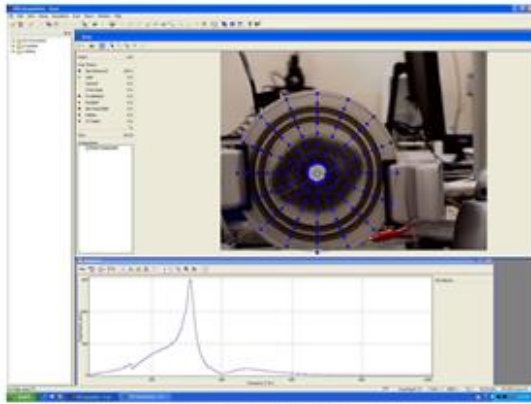

Center (peak at 310 hz)

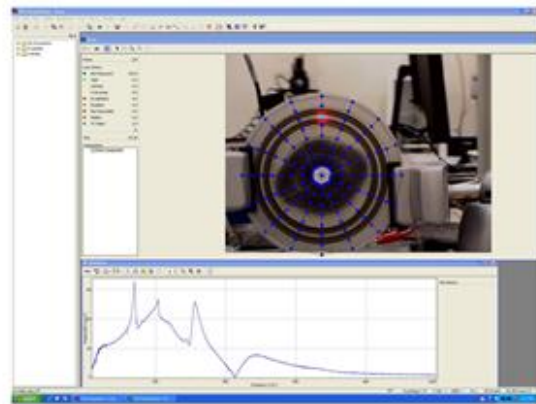

Racetrack (highest peak at 140 hz)

# Prototype #1 Version #1 (back)

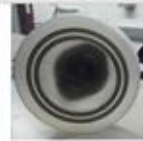

310 hz

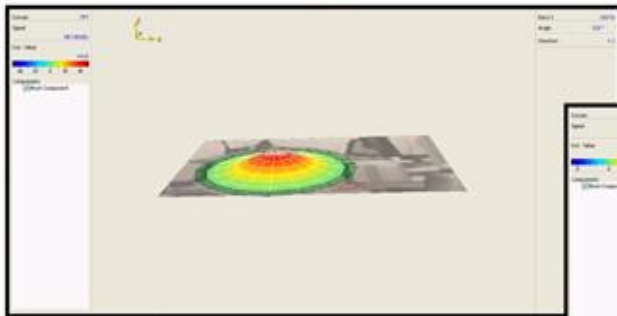

Video #1

140 hz



Video #2



# Prototype #1 Version #1 (front)

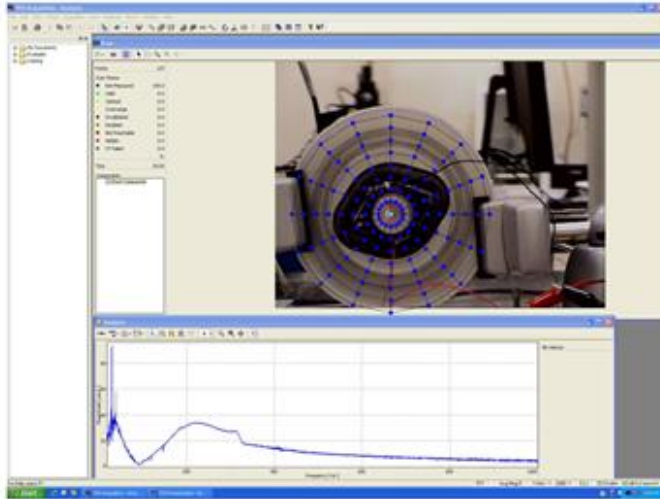

# Appendix E: Polytec Vibrometer Scans of Daffodil Box Design 1 version 2

## Prototype #1 Version 2 (back)

Peaks at:  
38 (spike)  
48 (spike)  
124

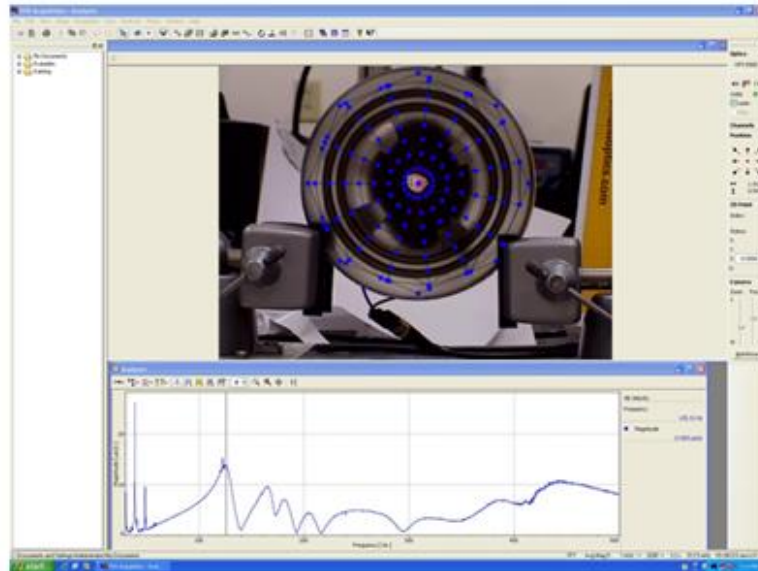

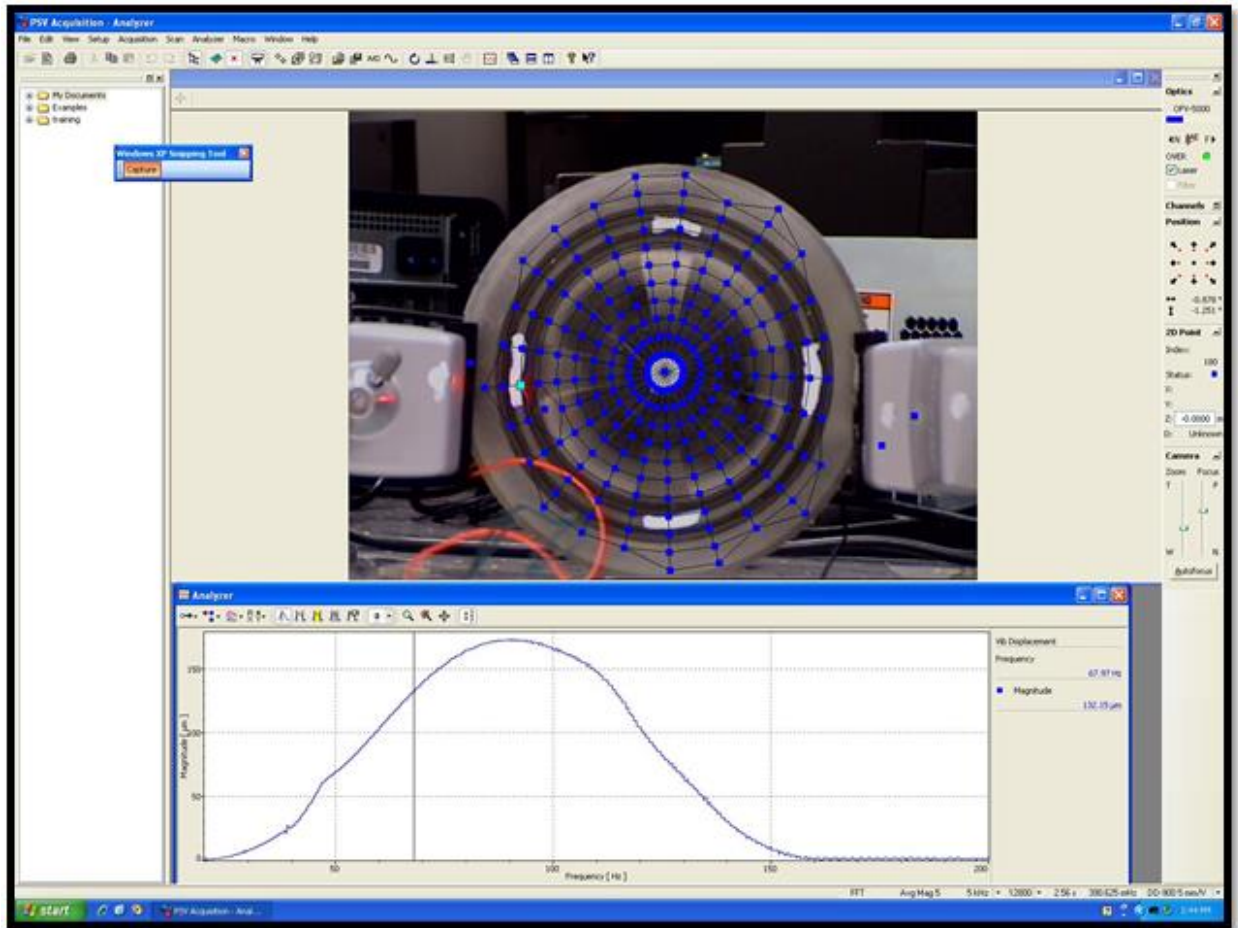

## Prototype #1 Version 2 (back)

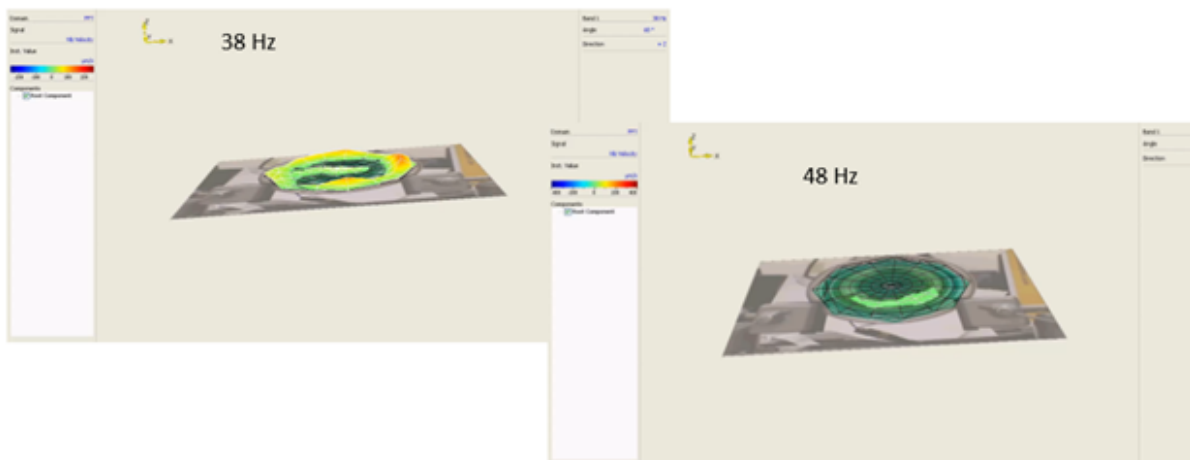

## Prototype #1 Version 2 (back)

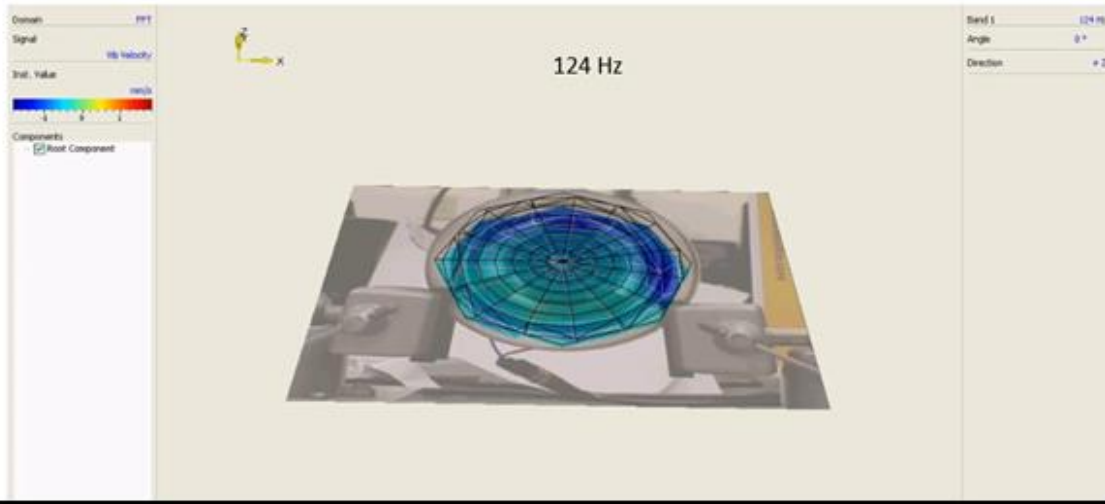

## Prototype #1 Version 2 (front)

Peaks at:  
38 (Spike)  
55  
124  
229(large peak)

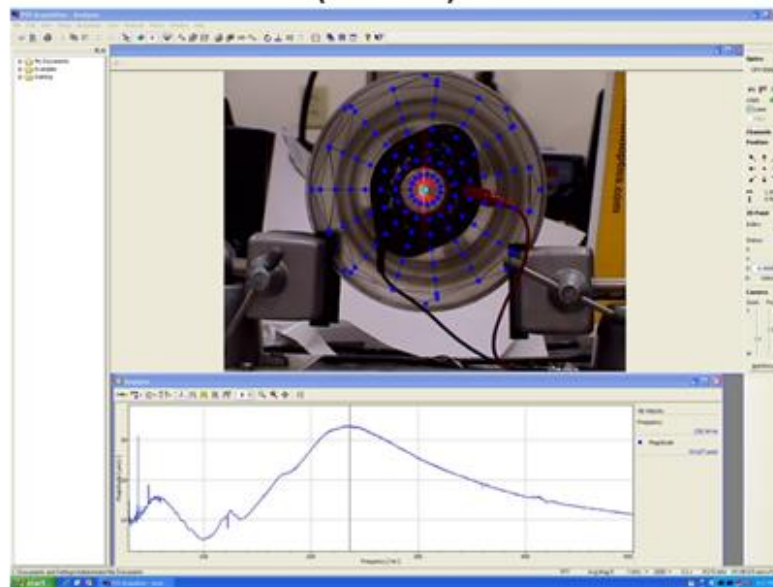

## Prototype #1 Version 2 (front)

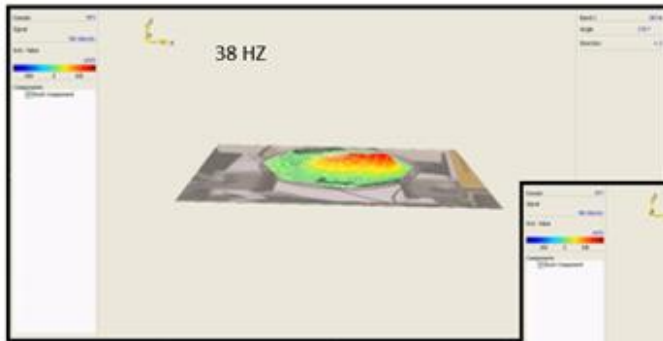

**\*\*Note:** the peak off to the right side of the center is because one of the alligator clips was in the way or the speaker

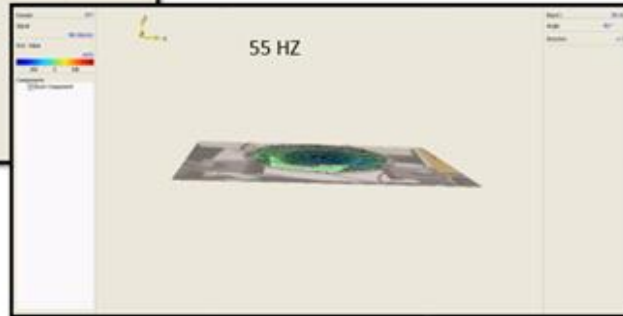

## Prototype #1 Version 2 (front)

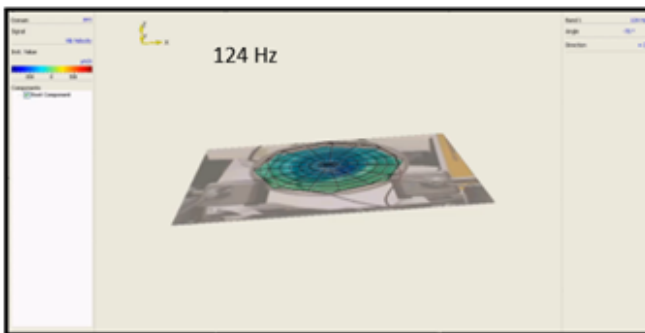

**\*\*Note:** the peak off to the right side of the center is because one of the alligator clips was in the way or the speaker

**\*\*We were not able to get a good scan for the 229Hz**

# Appendix F: Polytec Vibrometer Scans of Daffodil Design 2 Version 2

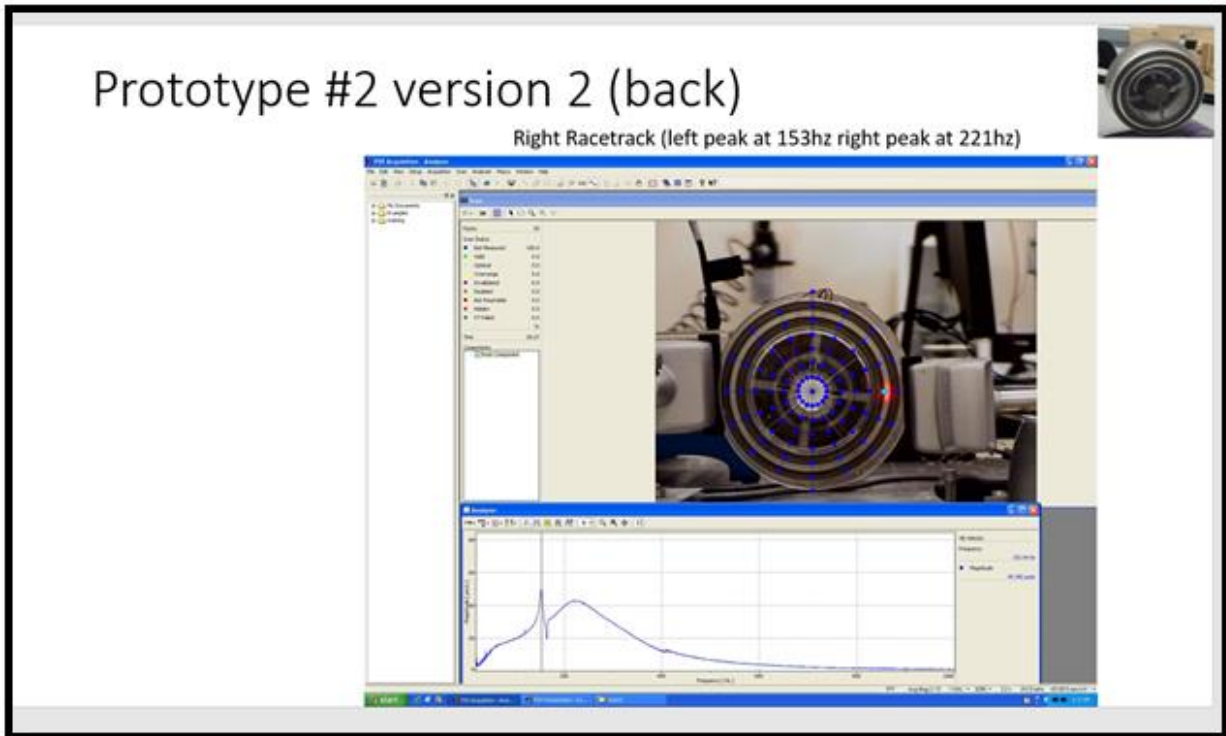
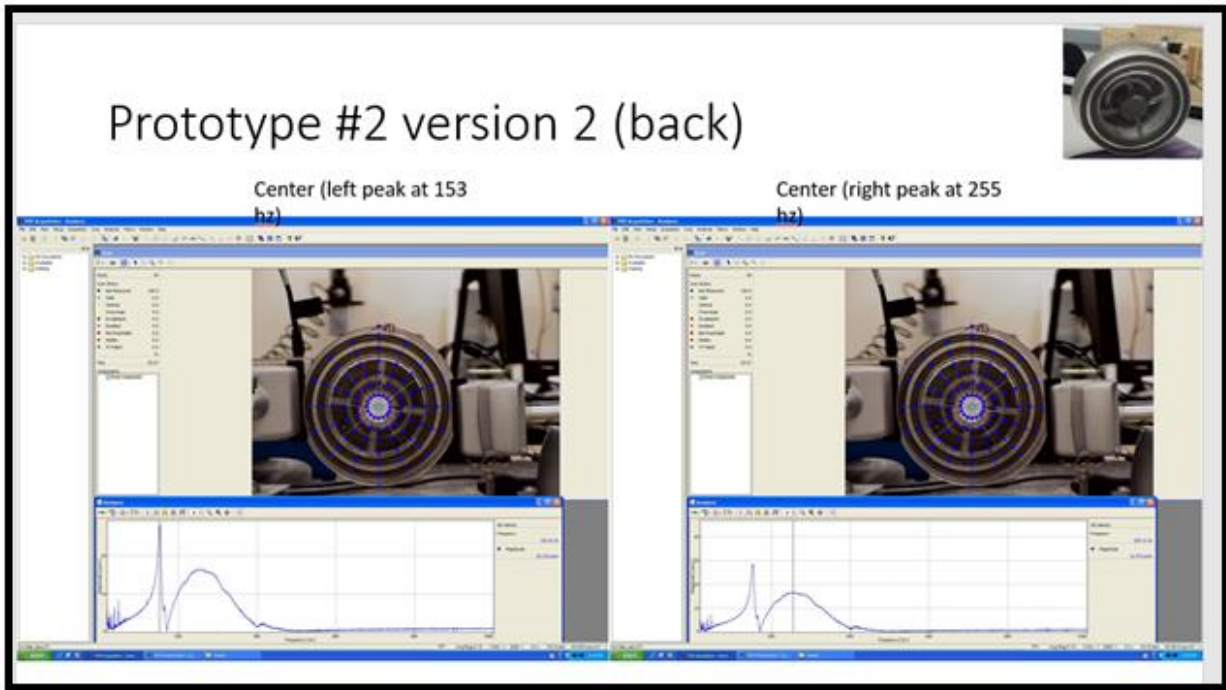

## Prototype #2 version 2 (back)



152 hz



Video #3

252 hz

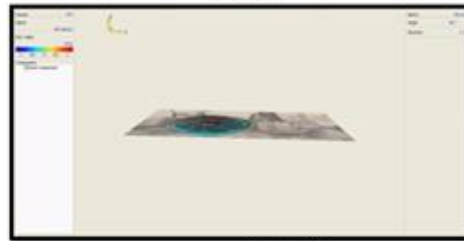

Video #4

221 hz

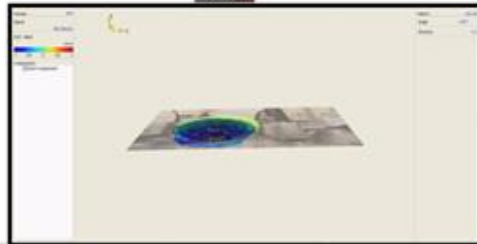

Video #5

## Prototype #2 version 2 (front)



Center (left peak at 223 hz)

Righth passive (right peak at 48 hz)

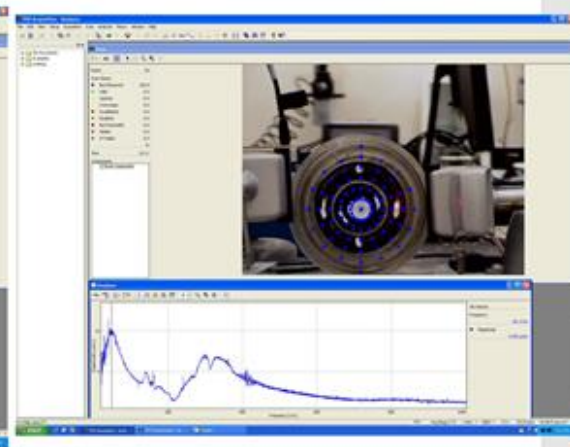
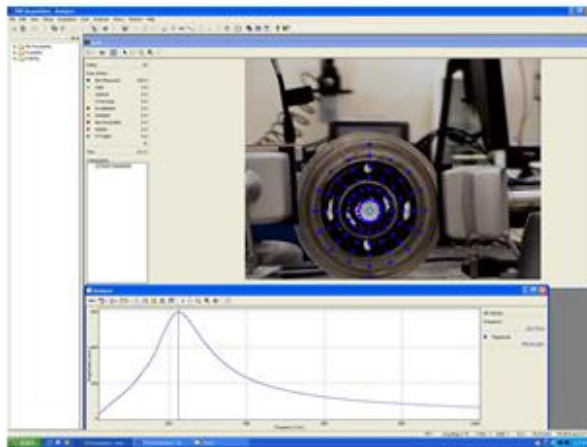

# Prototype #2 version 2 (front)



223 hz

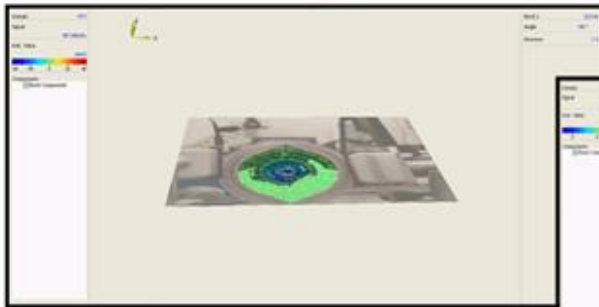

Video #6

48 hz

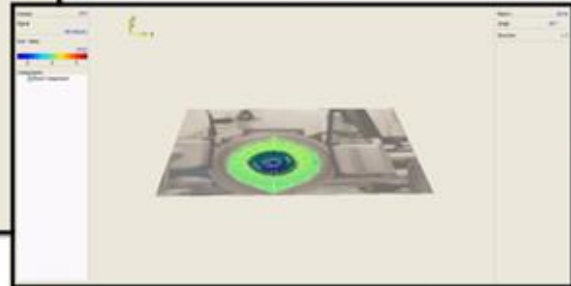

Video #7



# Appendix G: Polytec Vibrometer Scans of Daffodil Box Design 2 Version 3

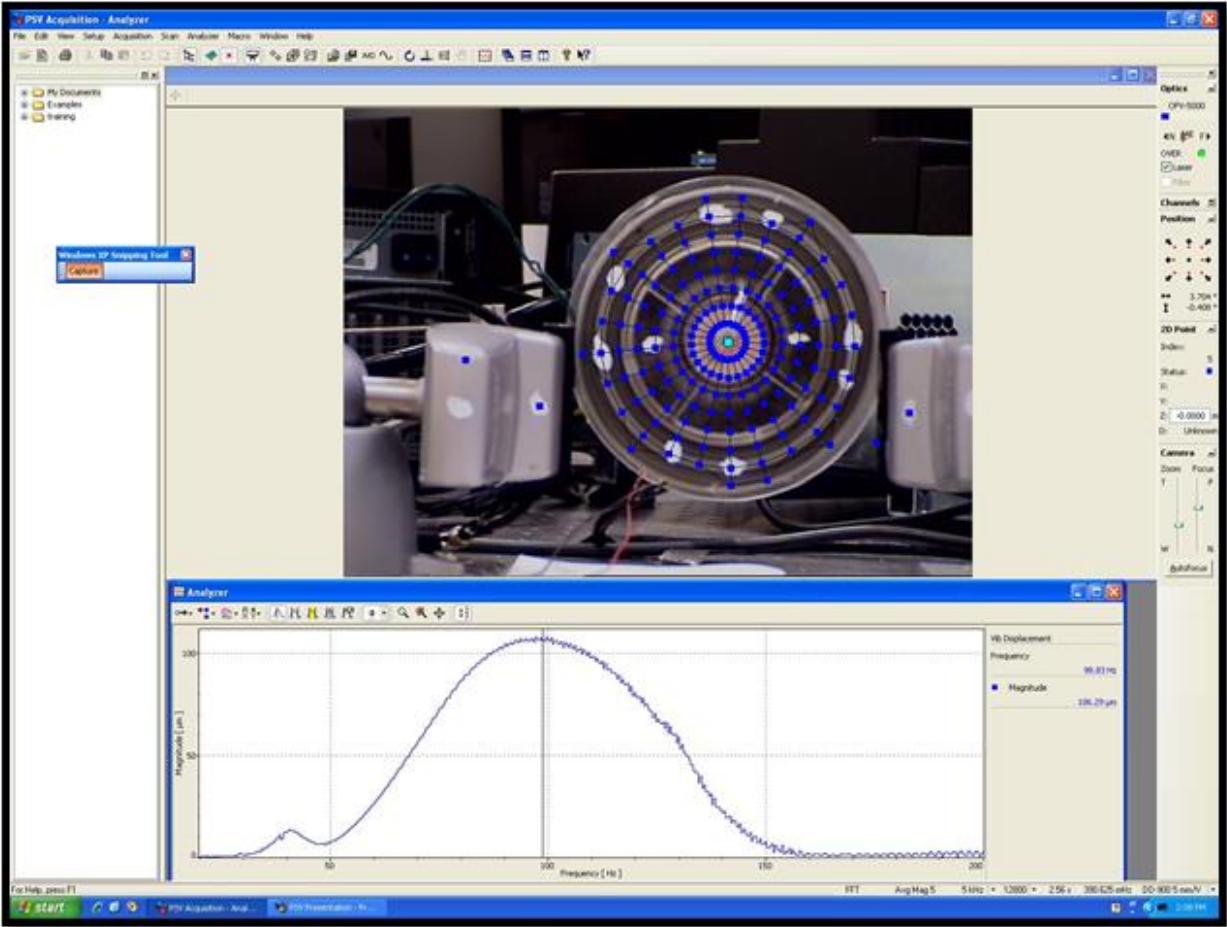

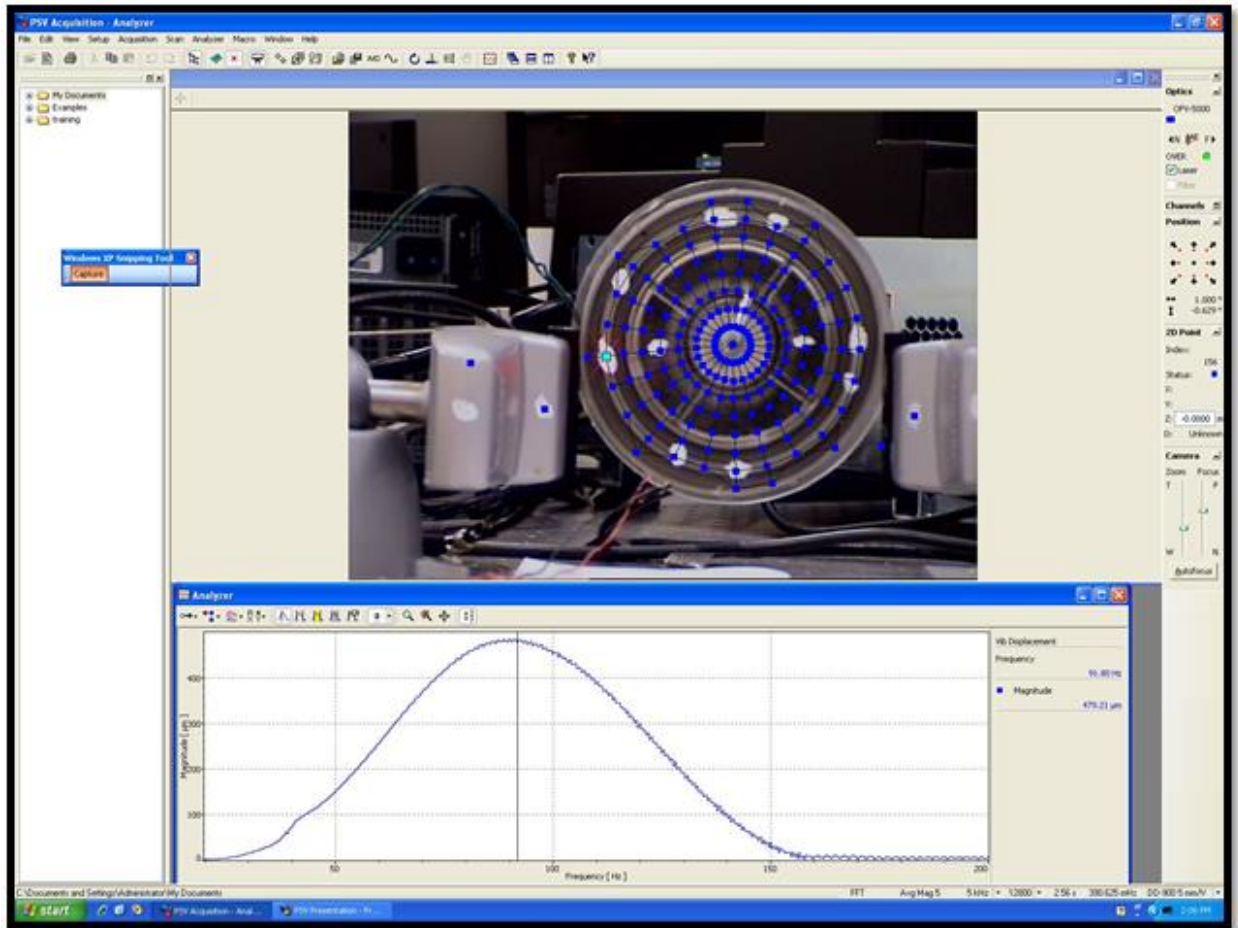

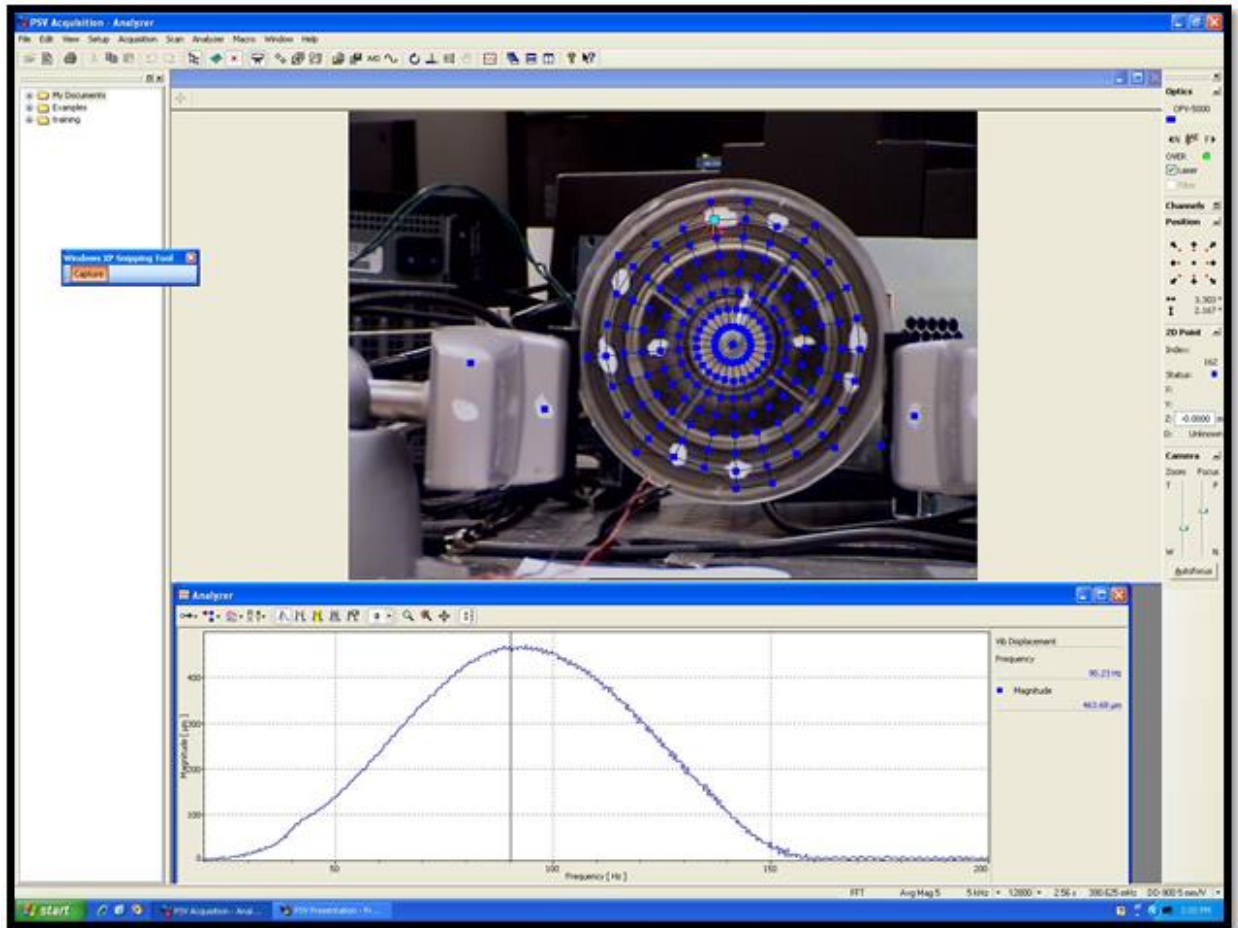

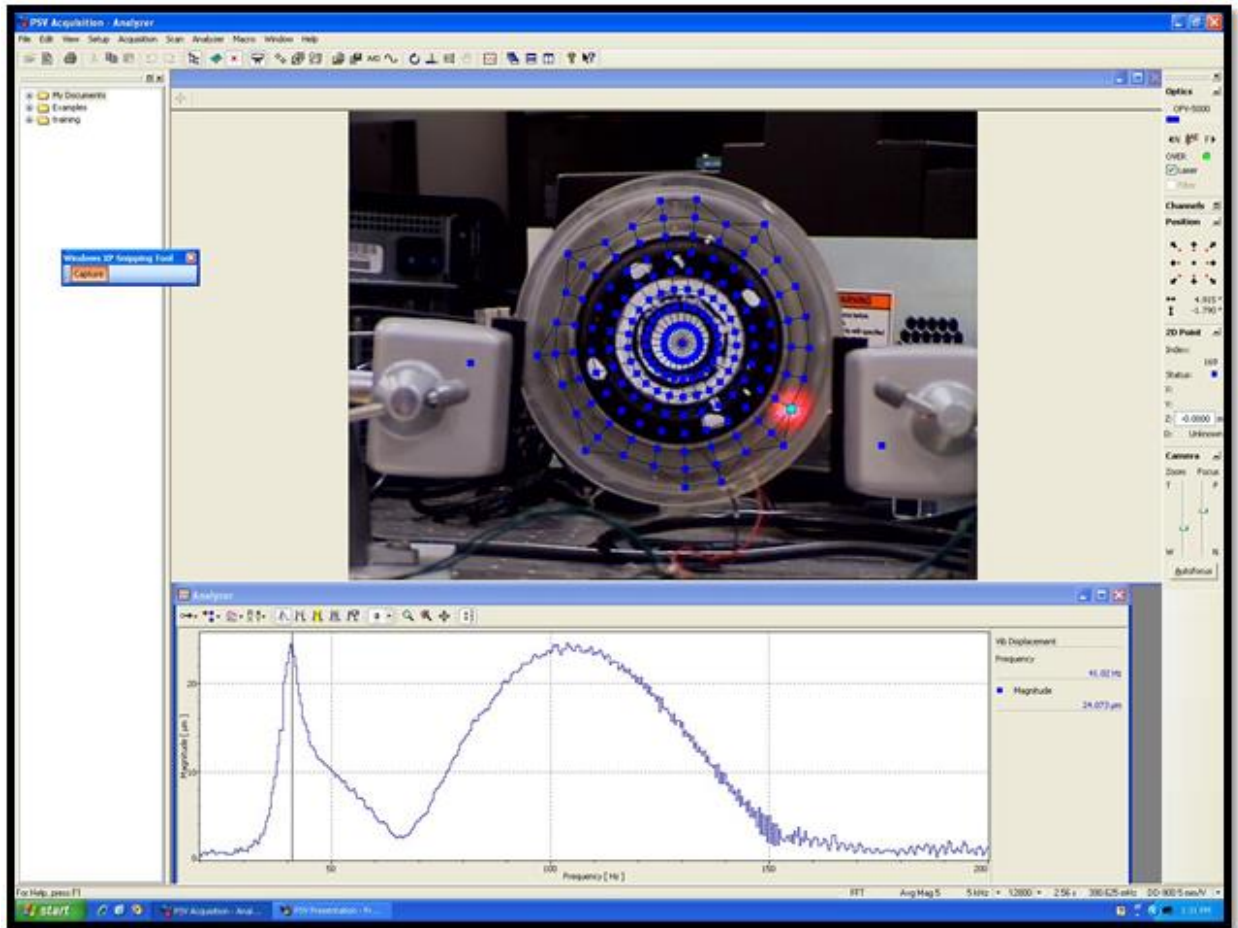

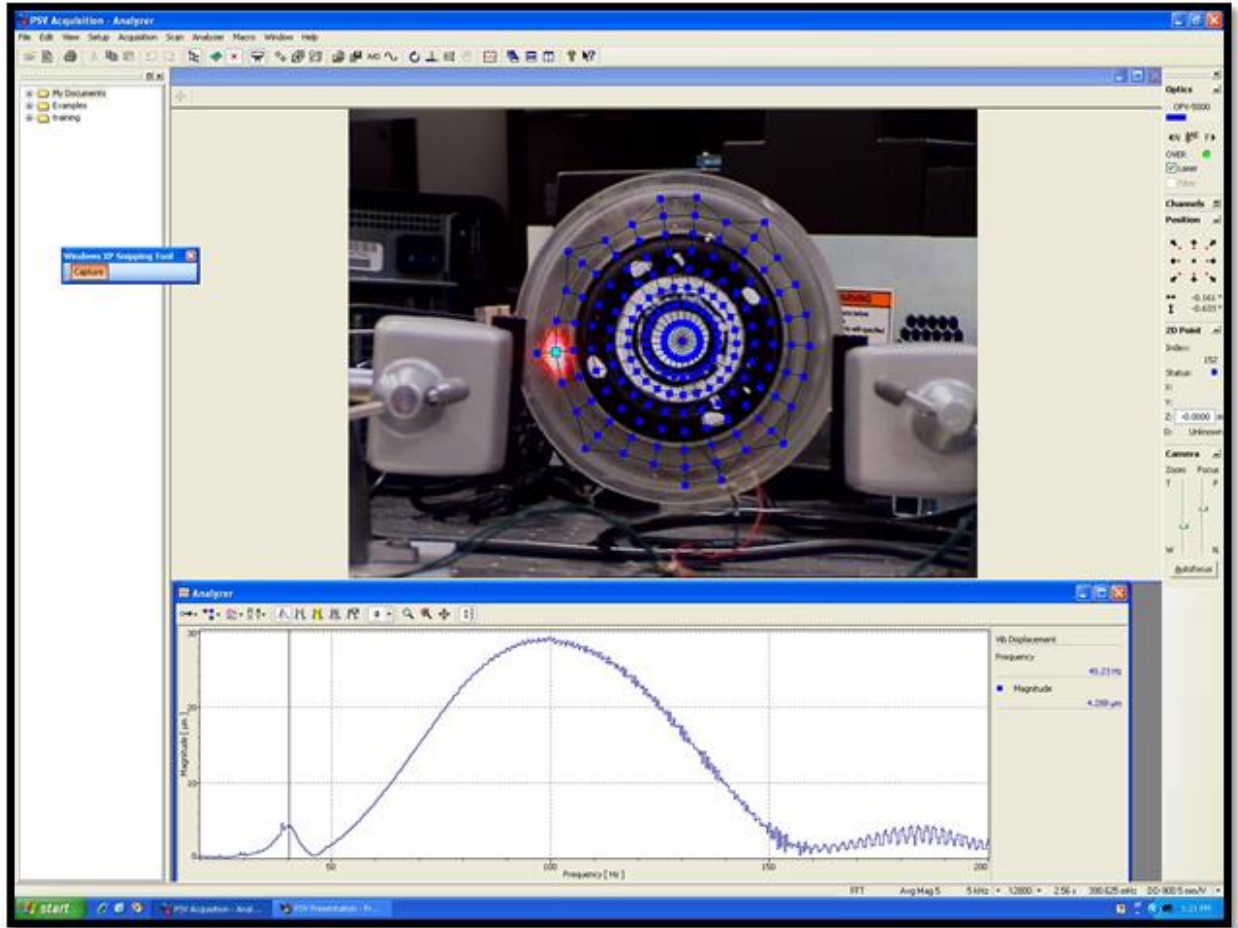

## Appendix H: Polytec Vibrometer Scans of Moving Magnet Box Design 1 Version 4 (Final Design)

Since there were 6 of these prototypes printed there are 6 subsections in this appendix (one for each print). This was done to ensure that all of the prints operated identically.

# Print 1: Moving Magnet Box Design 1 Version 4

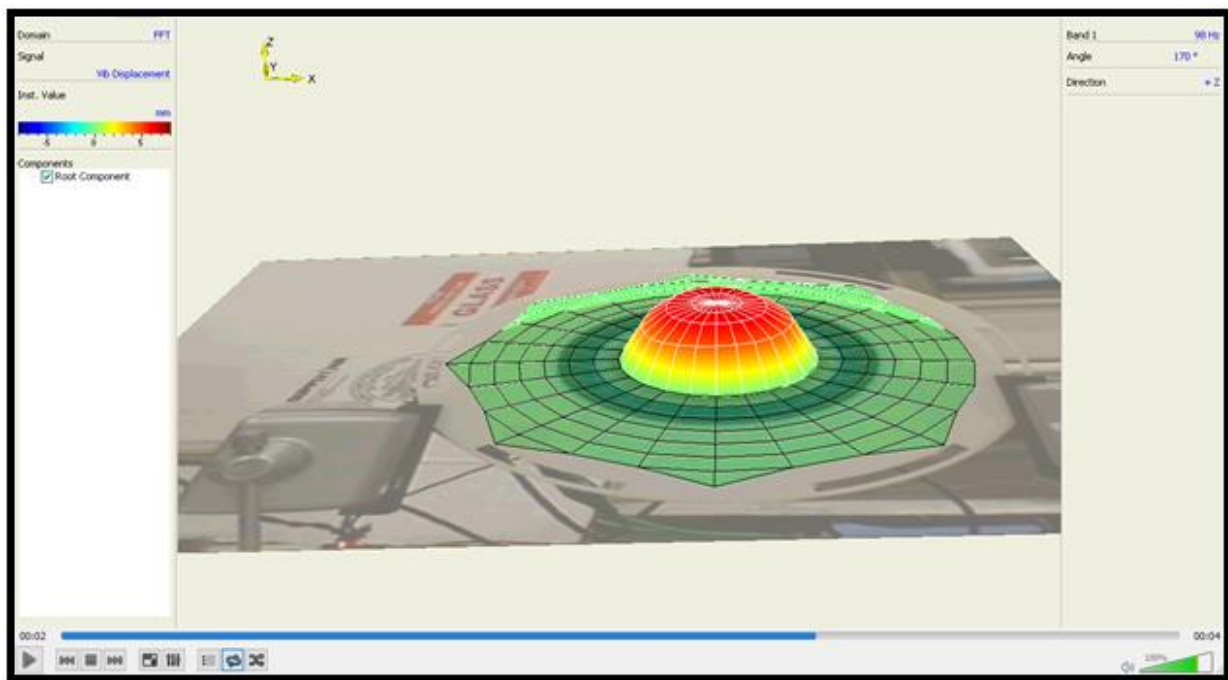
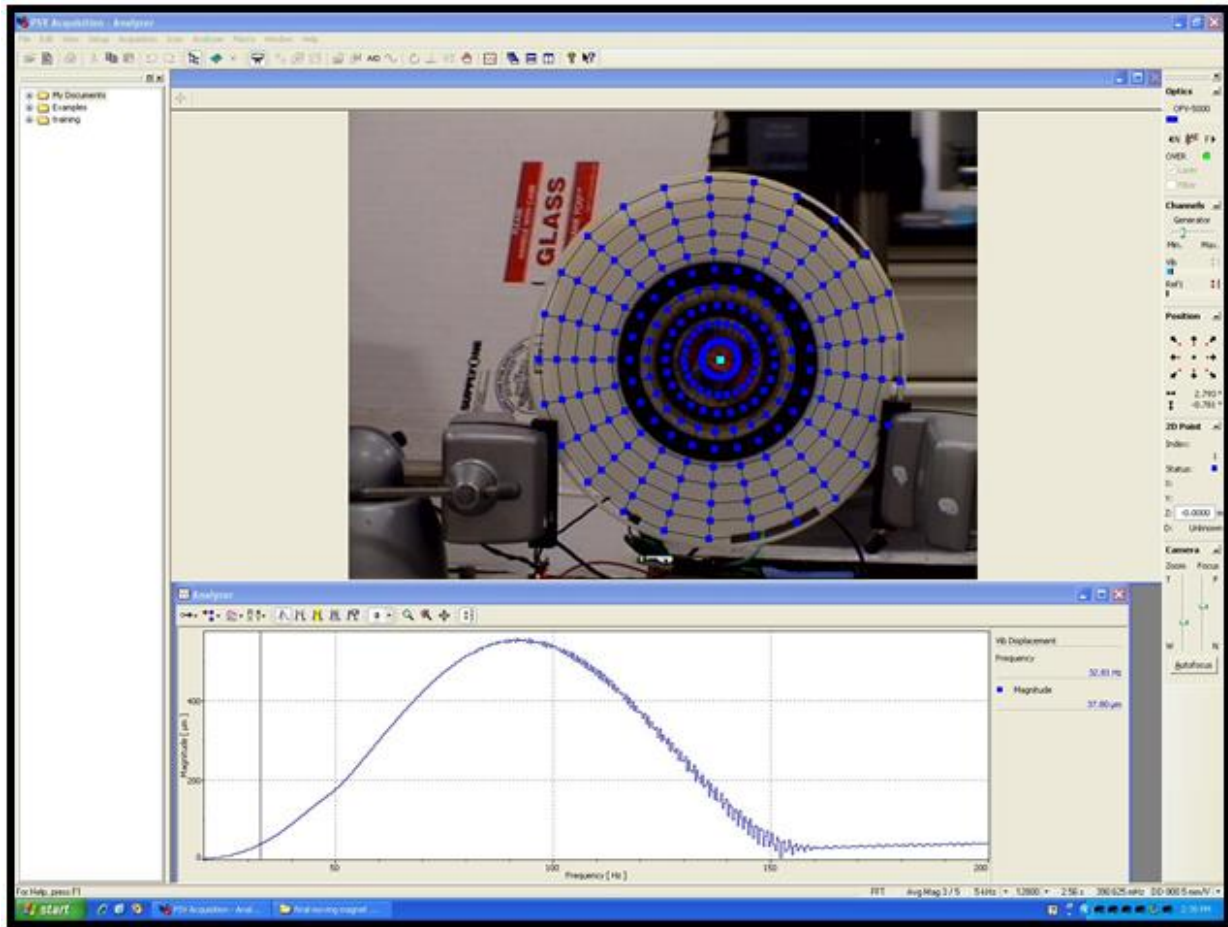

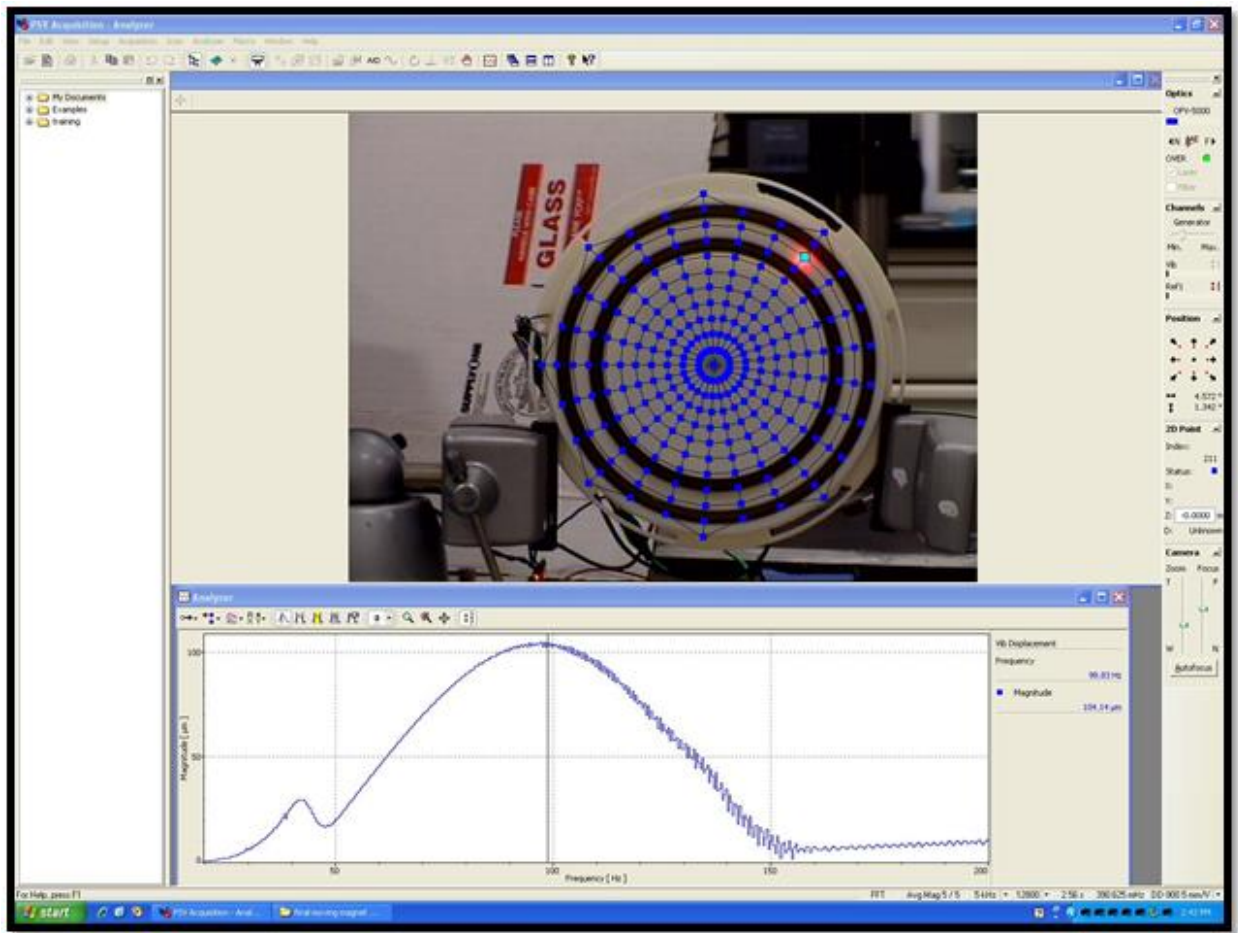

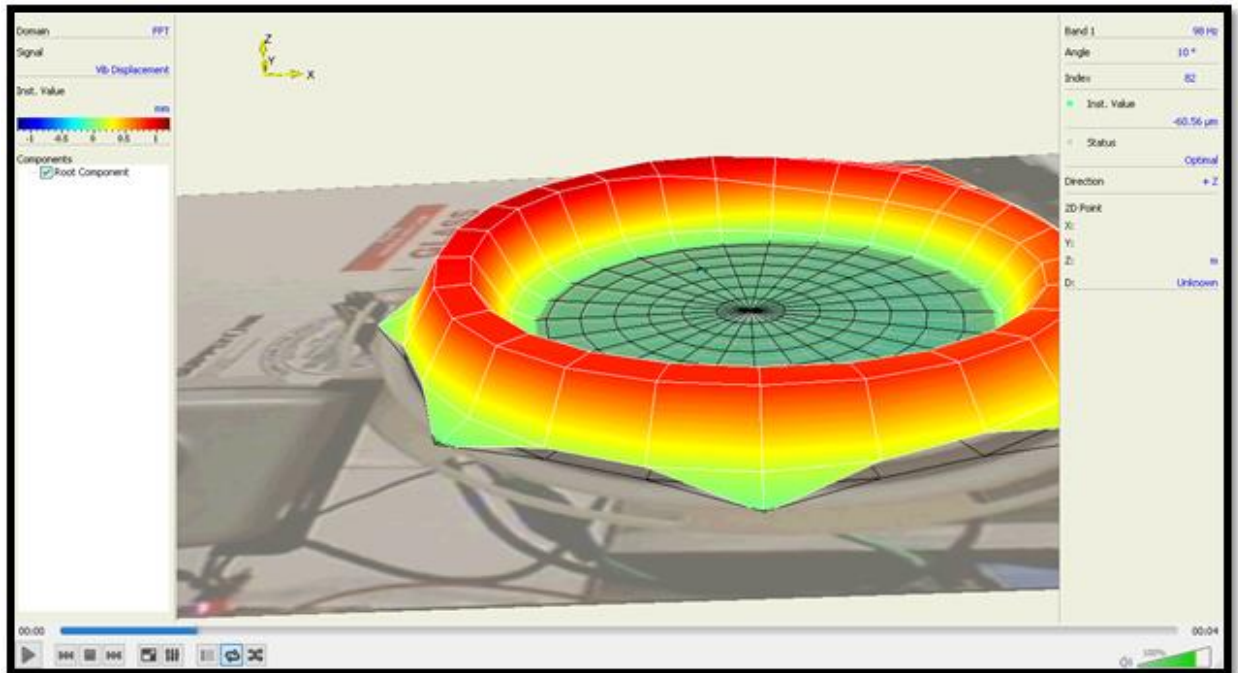
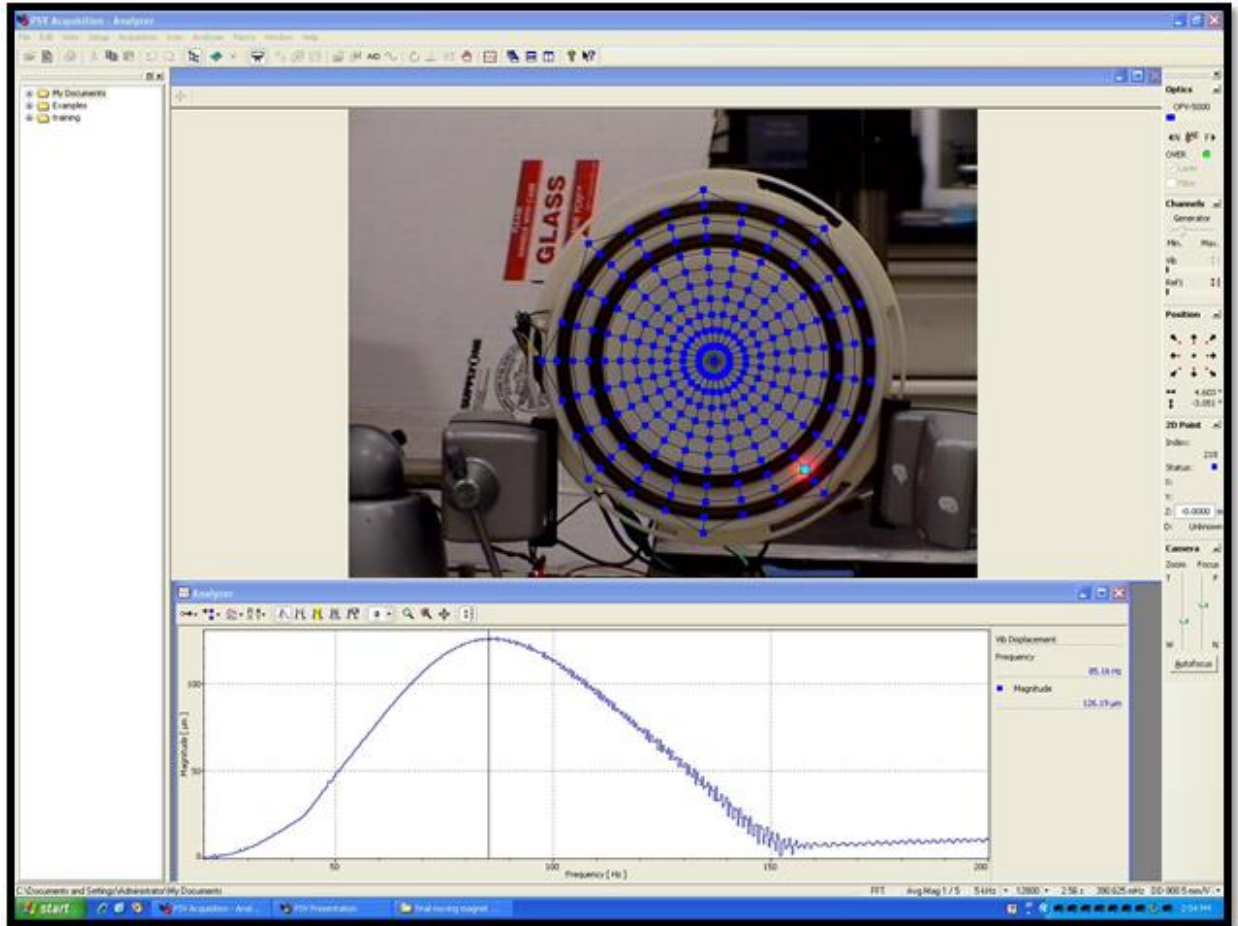



Print 2: Moving Magnet Box Design 1 Version 4

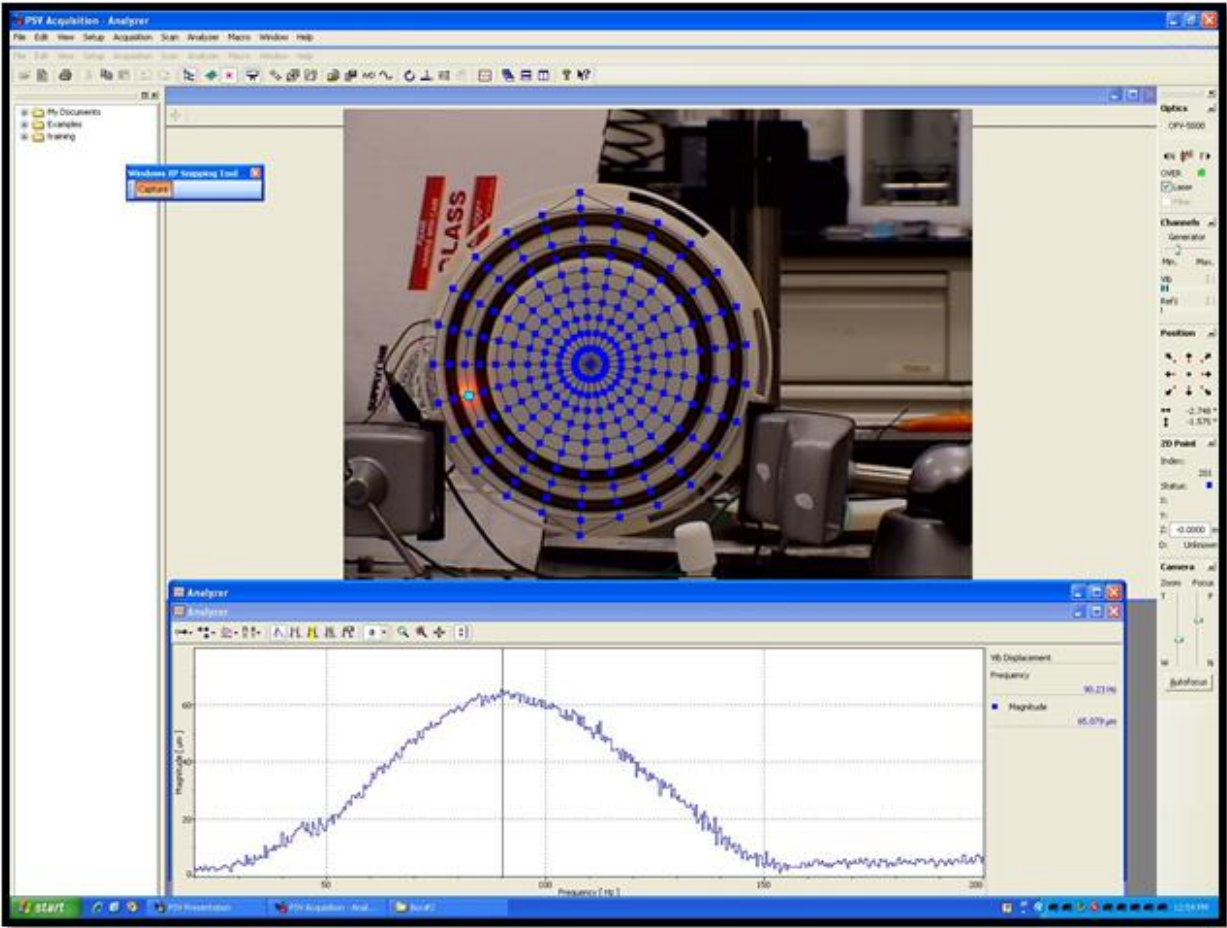

# Print 3: Moving Magnet Box Design 1 Version 4

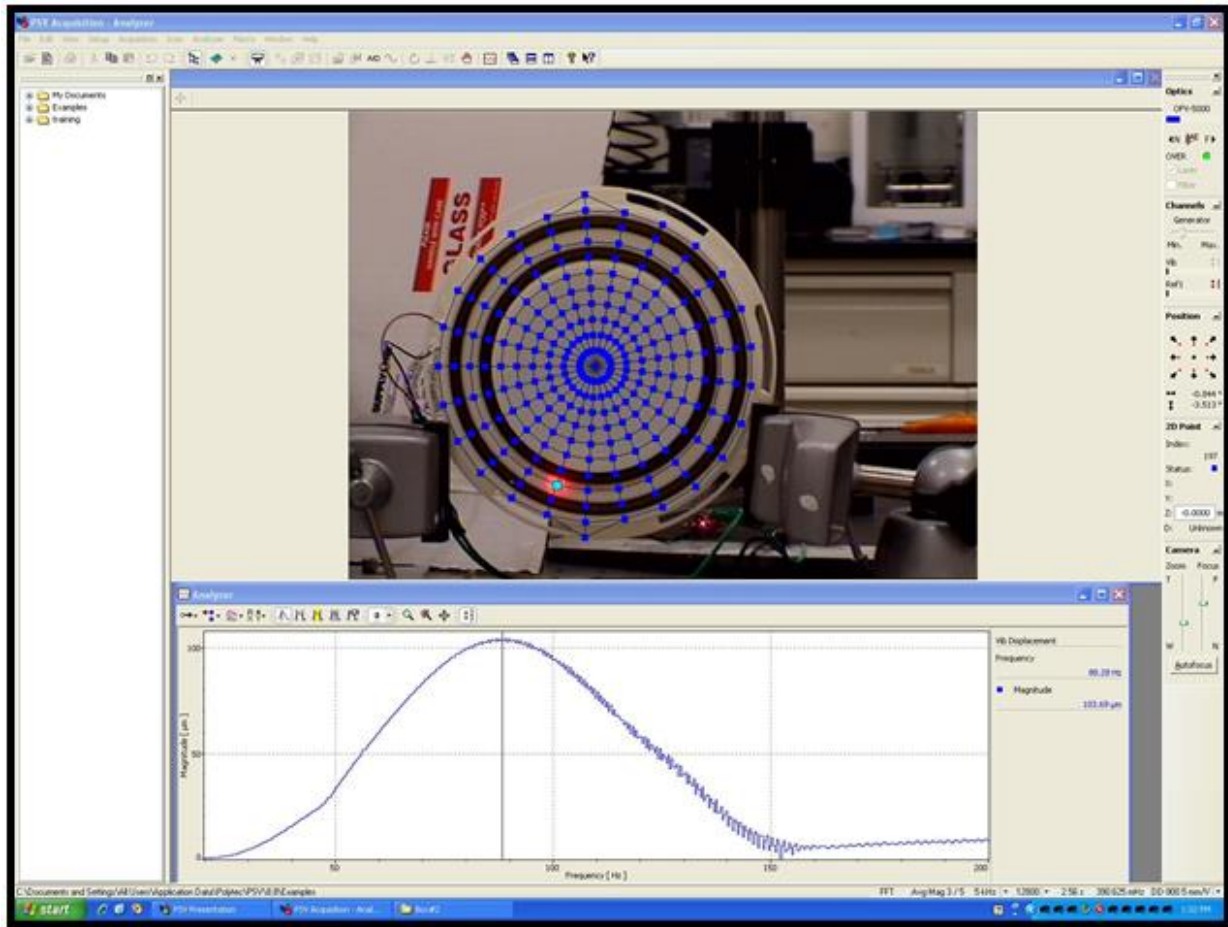

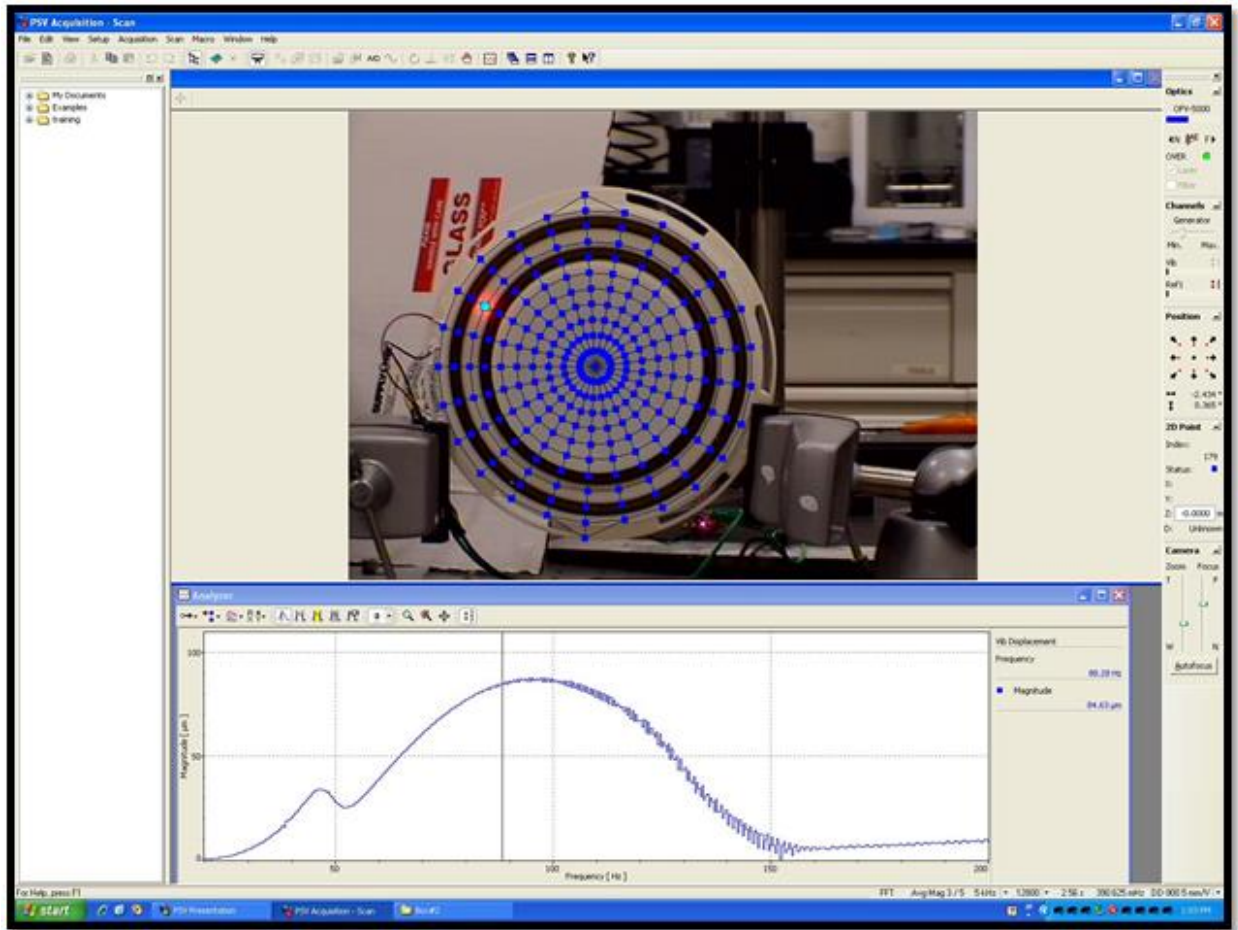

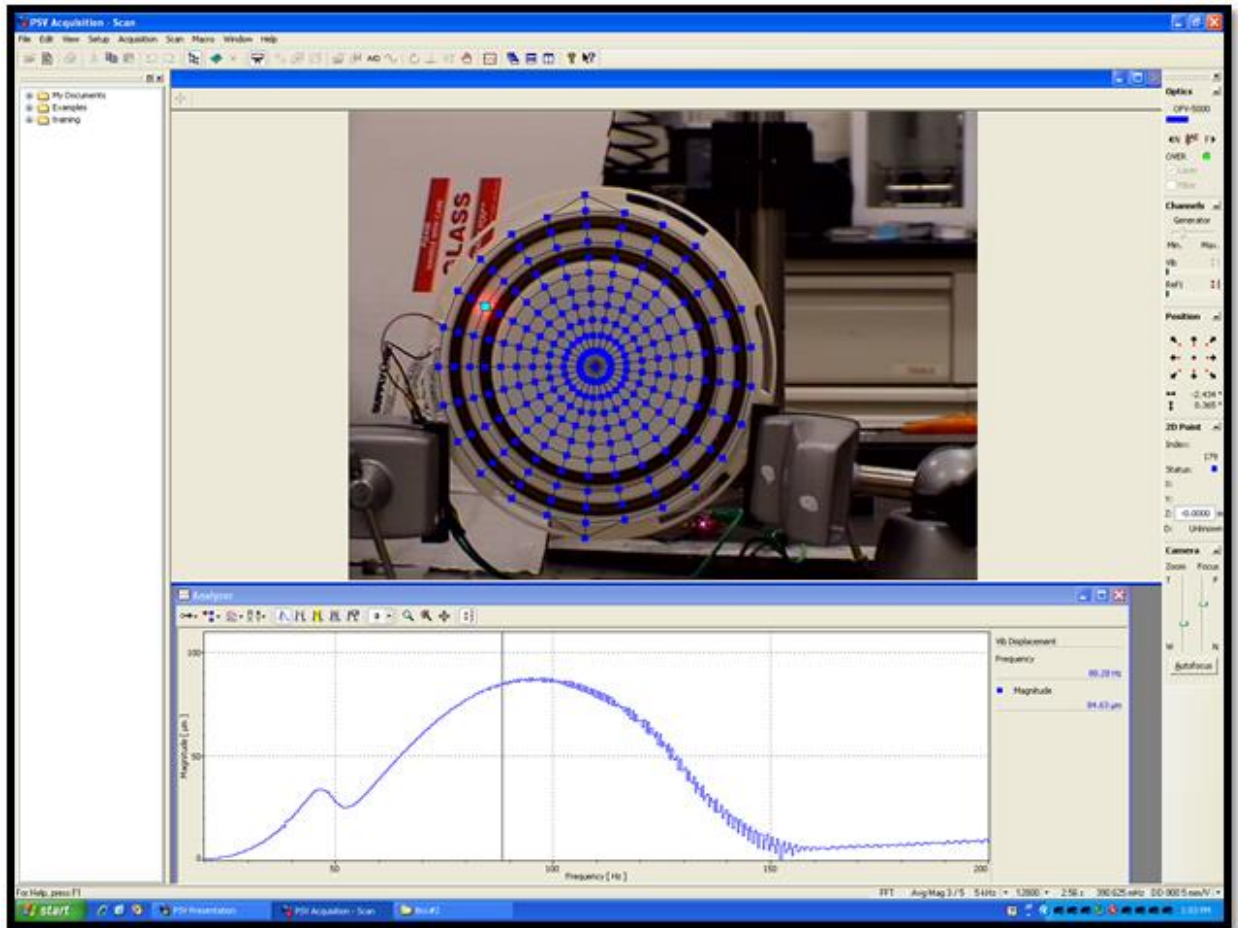

# Print 4: Moving Magnet Box Design 1 Version 4

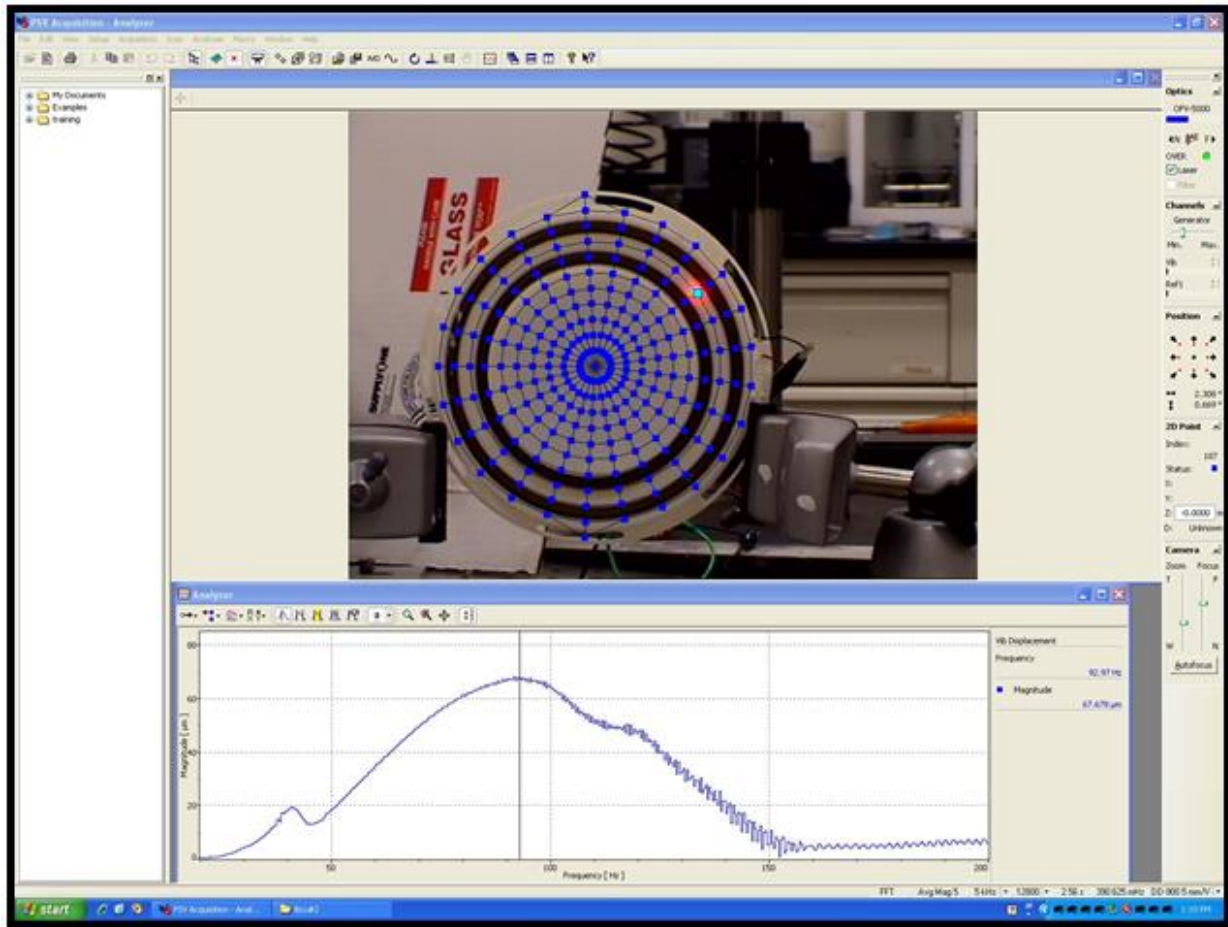

# Print 5: Moving Magnet Box Design 1 Version 4

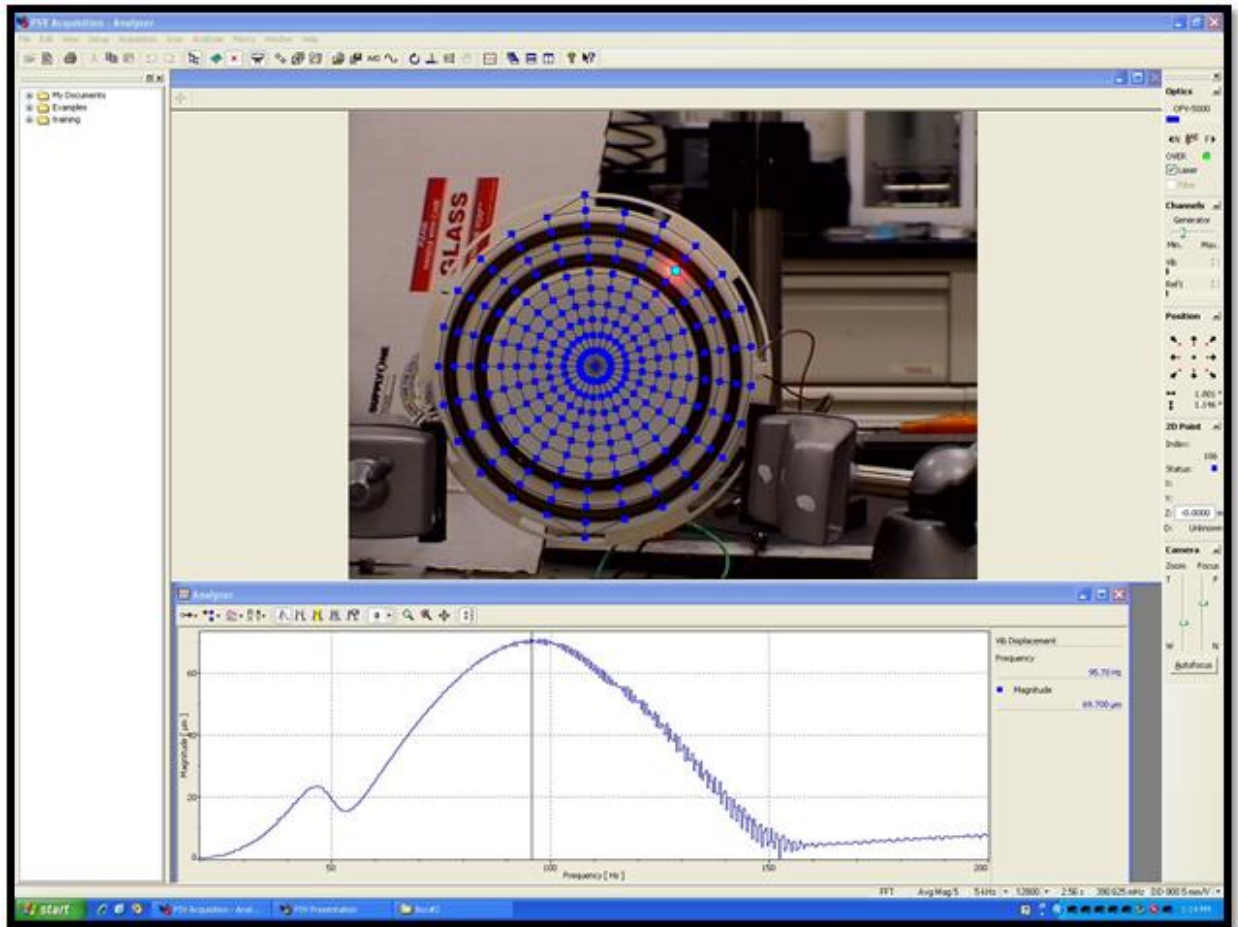

# Print 6: Moving Magnet Box Design 1 Version 4

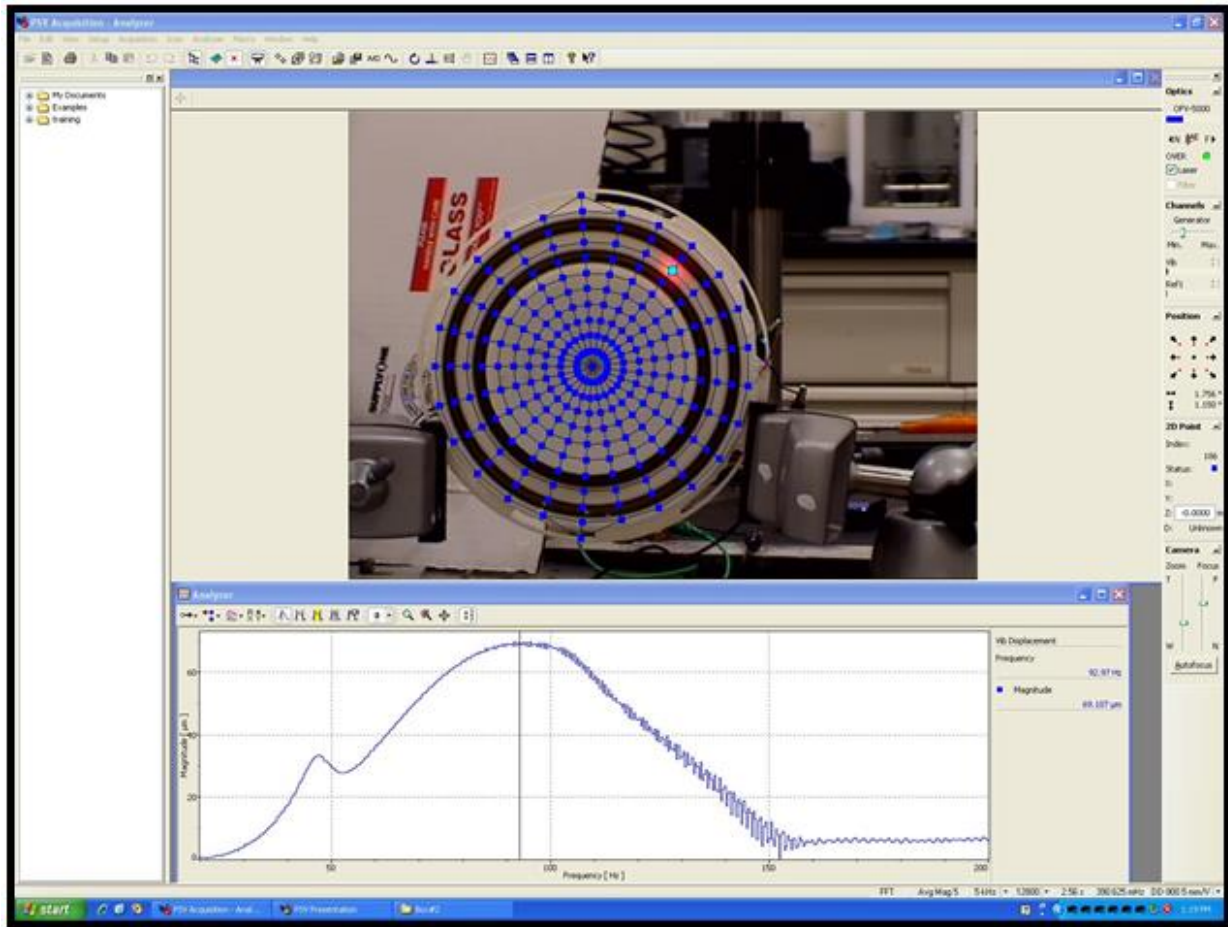

## Appendix I: How to Use Simscape to Model a Speaker System

In order to use Simscape to model the speaker system, the first step involved learning how to model a simple model. On MathWork's website, a tutorial page titled "Creating and Simulating a Simple Model" gave detailed instructions on how to model a system comprised of a mass, a spring and a damper, which can be found on this website: <https://www.mathworks.com/help/physmod/simscape/ug/creating-and-simulating-a-simple-model.html>. Follow these instructions to build a simple model and learn how to simulate the model and obtain position and velocity data.

In addition to finding block components in the Foundation Library Browser as the instructions present, within the model window, a user can type in the component they wish to include into the model and click on the component name. For the speaker system, a "Chirp Signal" was utilized instead of the "Signal Builder" Once you run the model and are able to see that the position and velocity data is functional, right click the line that connects the "Signal Builder" block with the "Simulink-PS Converter." Locate "Linear Analysis Points" on the dropdown menu and click "Input Perturbation." Next, right click the line that connects the "PS-Simulink Converter" to the "Position" scope block. Locate "Linear Analysis Points" on the dropdown menu and click "Output Measurement." These two linear analysis points enable the user to perform a linear analysis with specified inputs and outputs. In order to perform a linear analysis, which will be needed once the final model is created, click on Analysis on the Menu Bar at the top of the screen. From the dropdown menu, locate "Control Design," click on "Linear Analysis" and then click on "Bode." Click on "Bode Plot 1" and "Plot Preferences" in order to change the axis titles, the type of units the data presents and the limits on each axis. The Bode graph will be used in later models to display the peak frequency responses.

Creating a double mass-spring-damper model was the next step performed in order to represent the transducer and the front passive radiator. In order to create this system, simply delete the line connecting the Mechanical Translational Reference to the Spring and Damper connection. Next, copy the Mass, Spring, and Damper blocks and paste them into the model window or locate each block item in the Foundation Library. Adjust the parameter values by double clicking the block you wish to alter. Connect



the new mass to the Spring and Damper block from the single mass-spring-damper system, as presented below. Connect the new Spring and Damper blocks the same way in which the single mass-spring-damper system was modeled, then reconnect the Mechanical Translational Reference and Solver Configuration to the new Spring and Damper blocks. Re-run the model to ensure functionality.

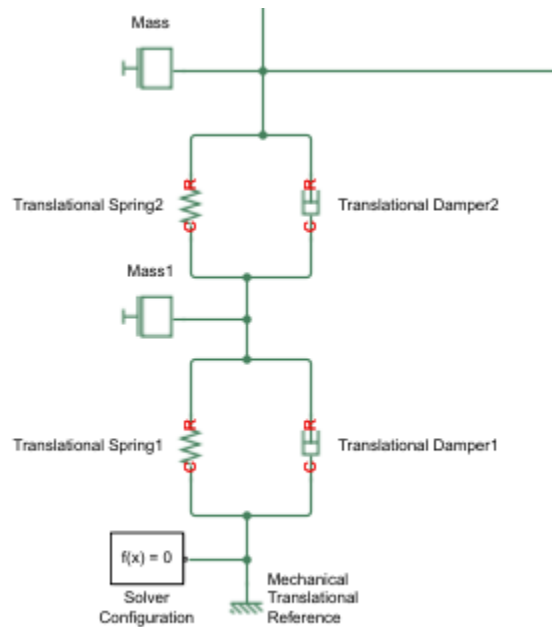

In order to model the speaker system, pneumatic components also need to be included to represent the air within the speaker box. From the Foundation Library within the Simscape tab of the Simulink Library, expand the Gas tab. Click on Elements and drag in a Translational Mechanical Converter block. Next, drag in a Gas Properties block which can be found in the Utilities tab. In addition to gas components, a thermal component is needed as well. Drag in a Perfect Insulator block which can be found under the Thermal Elements tab within the Thermal tab in the Foundation Library.

The speaker and both the rear and front passive radiators require their own Translational Mechanical Converter block, a ground reference point, a Perfect Insulator and a Mass, Spring, and Damper block. Using the double mass-spring-damper model created above, connect the Translational Mechanical Converter to the first mass, parallel to the Spring and Damper blocks. Attach the Perfect Insulator block to the “H” port, the ground block to the “C” port and the Gas Properties block to the “A”

port. Repeat this step for the second mass as well, using a second Translational Mechanical Converter, Perfect Insulator and ground block. Attach the “A” port to the same line that connects the first “A” port to the Gas Properties block. The image below displays how to properly connect each of the above mentioned components. The Translational Mechanical Converter is placed parallel to the spring and damper since the mass acts on all three components within the speaker system. The Translational Mechanical Converter acts as an air spring and is reacted on by the mass and also acts back on the mass. The Gas Properties block acts as a volume chamber that is representative of the volume of the speaker box.

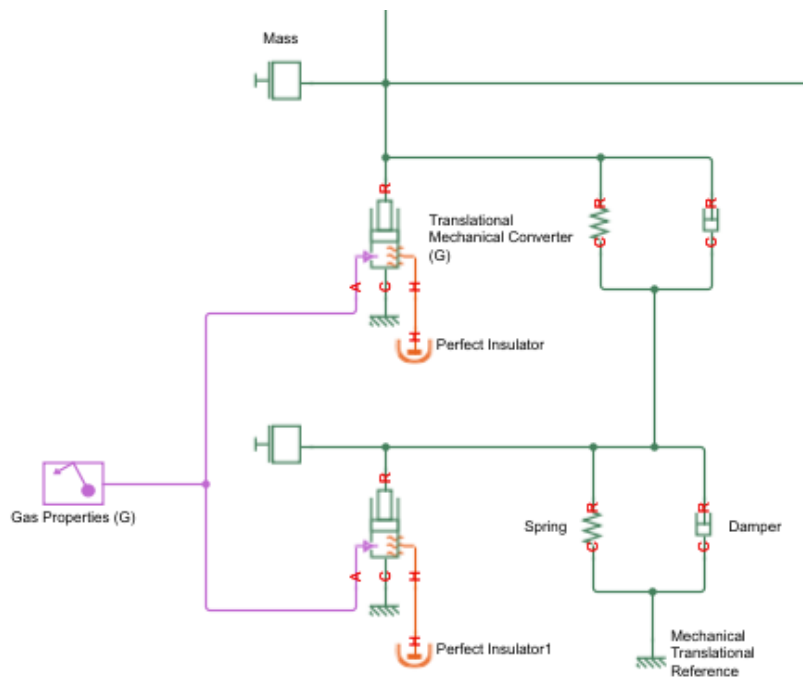

Once the double mass-spring system representative of the speaker and front passive radiator are built, the rear passive radiator can be incorporated into the Simscape model. The picture below displays how the rear passive radiator component can be added into the model in the image above. Similar to the front passive radiator and the speaker, the rear passive radiator has a Translational Mechanical Converter that connects to the Gas Properties block, a ground reference, and a Perfect Insulator block. However, since the rear passive radiator acts as a single mass-spring-damper system, the mass, spring and damper are only connected to the Translational Mechanical Converter instead of being connected to the front passive radiator’s mass-spring-damper connection. An Ideal Translational Motion Sensor was connected

to the rear passive radiator's mass, as well as a velocity and position scope graphs. Similarly to how the linear analysis was performed during the formation of the simple model, add the "Input Perturbation" onto the line connecting the Chirp Signal and the 'Simulink-PS Converter" and the "Output Measurement" between the "PS-Simulink Converter" and the Position1 block.

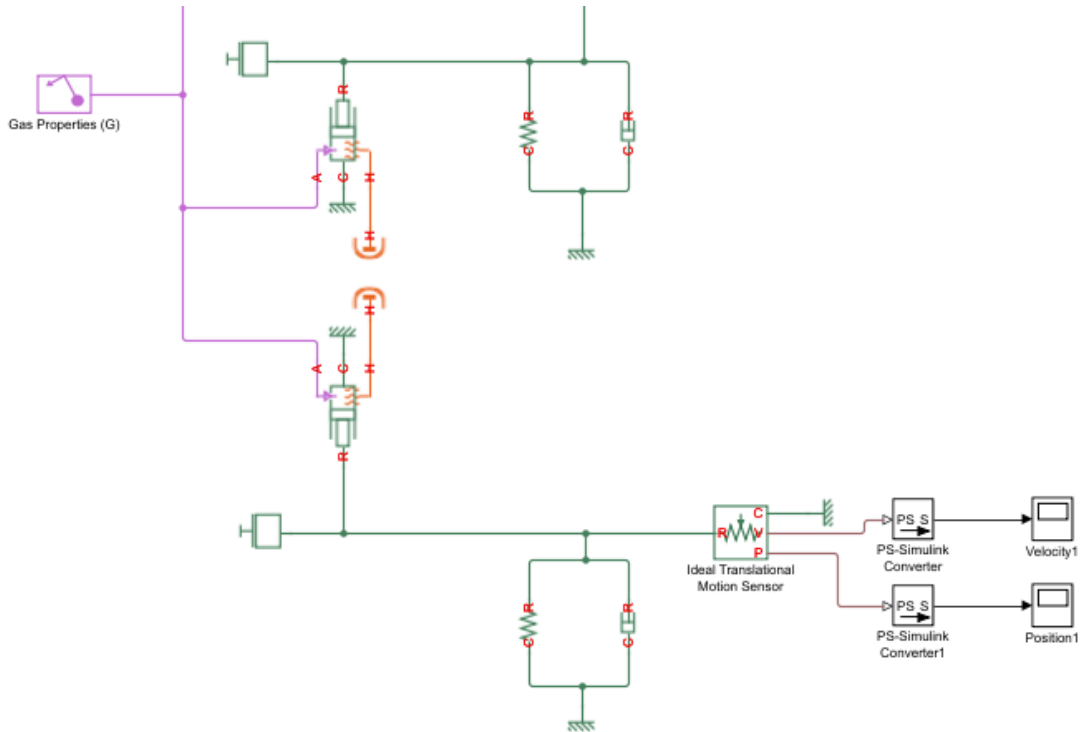

Once the entire model is created, the values can be entered into each component by double clicking on the block you wish to edit. For each spring block, the value entered is representative of the inverse of the compliance, since compliance is calculated as  $m/N$  and the spring on Simscape uses units of  $N/m$ . For the damper, the inverse of the mechanical losses can be used, since the mechanical losses uses units of  $s/kg$  and Simscape uses units of  $N/(m/s)$ . The mass of the speaker is representative of the moving mass of the transducer. The mass of the front passive radiator reflects the mass of the surround as well as the mass of the transducer. The rear passive radiator's mass is reflective of the mass of the racetrack. Each Translational Mechanical Converter's interface cross-sectional area is reflective of the effective areas, which is discussed in previous sections. For our model, the cross-sectional area at port A was set as  $0.01 \text{ m}^2$  and the dead volume was set to  $0.00001 \text{ m}^3$ . These two values helped in not interfering with the

analysis, as they had previously when larger values were entered into them. The Gas Properties had the same cross-sectional area at port A entered and the volume of the speaker box can be entered into the chamber volume. The Chirp Signal can also be edited to set limits on the frequency inputted into the system. The final Simscape model can be seen below. The orientation of blocks does not affect the simulation outcome of the system, which is why the model displayed in the Results section looks different than this model. If any issues or questions arise during Simscape creation and analysis, MathWorks is a helpful resource to find answers. Between a combination of online resources and setting up video calls with a MathWorks employee, many obstacles were able to be overcome and our team was able to make improvements on the Simscape model.

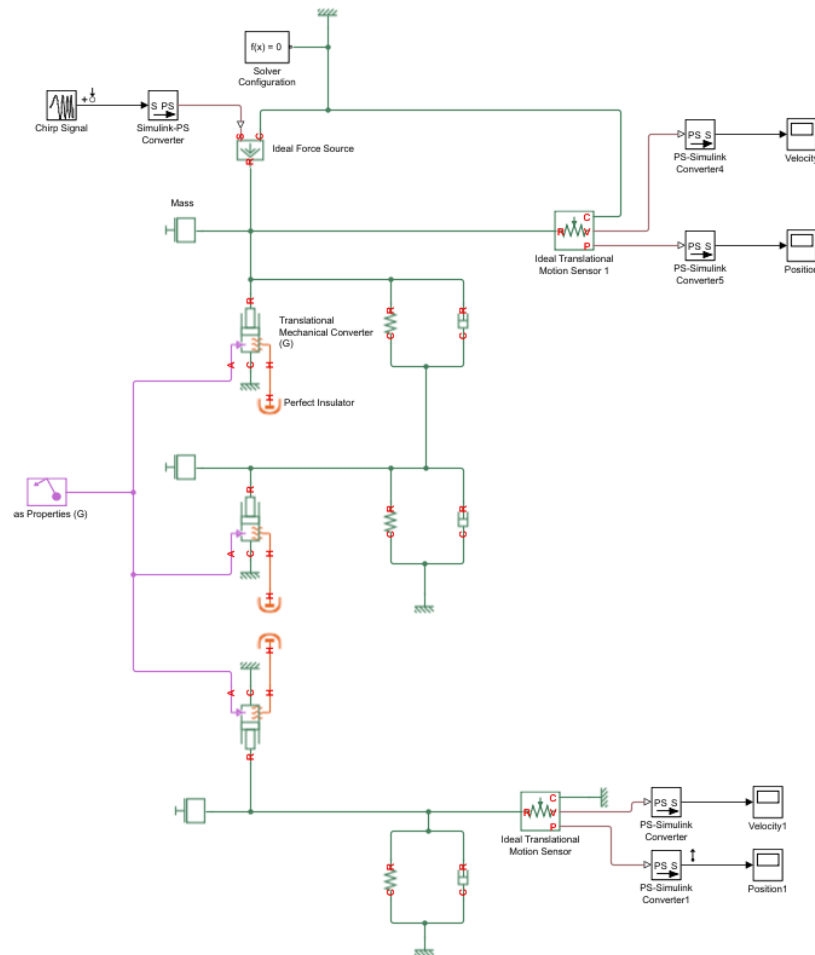

## Appendix J: Presentation on How to Use PSpice: Electro-Mechano-Acoustic Modeling

### Introduction to Electro-Mechano-Acoustical Circuits

- It is the application of electric-circuit theory to solve mechanical and acoustical problems.
- It makes it easier to represent and visualize mechanical and acoustical components than using differential equations.
- It is simple to construct schematic diagrams in circuits that contain lumped elements where time is the only independent variable.

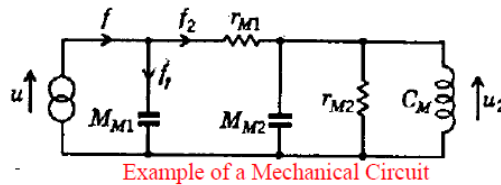







### Circuit Requirements

- There are requirements in order to design an electro-mechano-electric circuit, which are established through the following methods:
  - 1) The methods must allow the formation of schematic diagrams from visual inspection.
  - 2) They must be capable of allowing the combination of electrical, mechanical, and acoustical elements.
  - 3) They must preserve the identity of each element.
  - 4) They must use familiar symbols and the rules of manipulation of electrical circuits.

# Circuit Elements







- Two types of generators:
  - 1) Constant-drop generator
  - 2) Constant-flow generator
- Four types of circuit elements:
  - 1) Resistance
  - 2) Capacitance
  - 3) Inductance
  - 4) Transformation
- Three types of generic quantities:
  - 1) Drop across a circuit element
  - 2) Flow through a circuit element
  - 3) Magnitude of a circuit element

Symbol	Name	Meaning	
		Transient	Steady-state
	Constant-drop generator	The quantity $a$ is independent of what is connected to the generator. The arrow points to the positive terminal of the generator	
	Constant-flow generator	The quantity $b$ is independent of what is connected to the generator. The arrow points in the direction of positive flow	
	Resistance-type element	$a = bc$	$a = bc$
	Capacitance-type element	$a = \frac{1}{c} \int b dt$	$a = \frac{b}{j\omega c}$
	Inductance-type element	$a = c \frac{db}{dt}$	$a = j\omega cb$
	Transformation-type element	$a = cg$ $cb = d$ $\frac{a}{b} = c \frac{g}{d}$	$a = cg$ $cb = d$ $\frac{a}{b} = c \frac{g}{d}$

Mathematical and Physical Meaning of Elements (Electrically)

# Continued: Circuit Elements

- For example, the drop across  $c$  in 3 is  $a$ . The value of  $a = b * c$ , which is the flow  $b$  multiplied by the magnitude of element  $c$ .
- Similarly, the drop across the inductance-type element in 5 is  $a$ . It can be found by multiplying the time derivative of flow  $b$  with the magnitude of element  $c$ .

Symbol	Name	Meaning	
		Transient	Steady-state
<b>1</b> 	Constant-drop generator	The quantity $a$ is independent of what is connected to the generator. The arrow points to the positive terminal of the generator	
<b>2</b> 	Constant-flow generator	The quantity $b$ is independent of what is connected to the generator. The arrow points in the direction of positive flow	
<b>3</b> 	Resistance-type element	$a = bc$	$a = bc$
<b>4</b> 	Capacitance-type element	$a = \frac{1}{c} \int b dt$	$a = \frac{b}{j\omega c}$
<b>5</b> 	Inductance-type element	$a = c \frac{db}{dt}$	$a = j\omega cb$
<b>6</b> 	Transformation-type element	$a = cg$ $cb = d$ $\frac{a}{b} = c \frac{g}{d}$	$a = cg$ $cb = d$ $\frac{a}{b} = c \frac{g}{d}$

Mathematical and Physical Meaning of Elements (Electrically)

# Mechanical Circuits



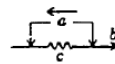
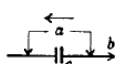
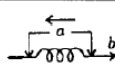

- Mechanical circuit elements have their own symbols.
- There are two types: Mobility and Impedance. However, we will only focus on the mobility-type elements as it is more intuitive mechanically and is preferred by Professor Stabile.
- From the adjacent table:
  - $e$  is open circuit output voltage
  - $u$  is velocity
  - $i$  is circuit current
  - $f$  is force
  - $M_M$  is mechanical mass
  - $C_M$  is mechanical compliance
  - The subscript M is for Mechanical

Element	Electrical	Mechanical	
		Mobility analogy †	
$a$	$e$	$u$	
$b$	$i$	$f$	
	$c = R_B$	$c = \frac{1}{k_M} = r_M$	
	$c = C_B$	$c = M_M$	
	$c = L$	$c = C_M$	

Values for a, b, and c in Electrical and Mechanical Circuits

## Mobility-type Analogy

- From this and the previous table, it is shown that in mechanical representation of circuit elements:
  - $u$  is analogues to the voltage
  - $f$  is analogues to the current flow
  - $M$  is analogues to capacitance
  - $C$  is analogues to inductance
- This analogies make sense because similar to current flow, it acts through the element, force acts through the mechanical element and cannot be measured unless one breaks into the device.

Element	MECHANICAL	
	Mobility type	
Infinite mechanical or acoustic impedance generator (zero mobility)		
Zero mechanical or acoustic impedance generator (infinite mobility)		
Dissipative element (resistance and responsiveness)		
Mass element		
Compliant element		

Mobility-type Analogy

## Dissipative Element

- In mobility-type analogy,  $r_M$  represents mechanical responsiveness and its unit is meters per second per newton.
- The following equation describes the relationship between velocity, force, and responsiveness.

$$u = r_M f$$

- This equation is analogous to ohms law,  $V = IR$

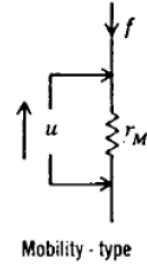

## Mass Element

- $M_M$  is the mass and it is represented by a capacitance-type element.
- It is measured in kg.
- The following equation shows its relationship with velocity and force.

$$f(t) = M_M \frac{du(t)}{dt}$$

- In steady state, the following equation is used to find the velocity where:
  - $j = \sqrt{-1}$  and  $w$  is  $2\pi * f$

$$u = \frac{f}{j\omega M_M}$$

- This equation is analogous to the electric-impedance equation  $V = \frac{i}{j\omega C}$

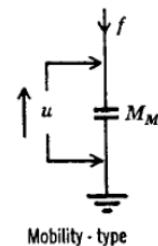



# Compliance Element

- $C_M$  is the compliance element and it is represented by an inductance-type element.
- It is measured in meters per newton.
- The following equation shows its relationship with velocity and force in steady state.

$$u = j\omega C_M f$$

- This equation is analogous to the electric-impedance equation  $V = j\omega LI$

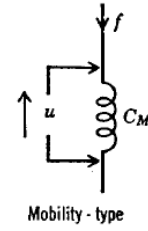

## Appendix K: Final Presentation to Bose Corporation

# The Synthesis and Improvement of a Force Balanced, Sealed Double Passive Radiator Bass Box for a Low Profile Home Speaker System

Team Delta

Nick Borsari, Brett Carbonneau, Karim Elsayed, Jeremy Honig



## Goals/Objectives

Goal: To design and improve a force-balanced, double passive radiator bass box for a low profile home speaker system.

Objectives:

- Implement and test transducers designed by the other sub-teams into the designed boxes and housings
- Come together collectively (all 5 sub-teams) as a group and develop a final low profile, wall-mounted home speaker system that is capable of producing good sound quality and range, producing good bass, and steering sound

## Background: Double Passive Radiator

- Referenced Patent "Acoustic device with passive radiators" by Joe Stable

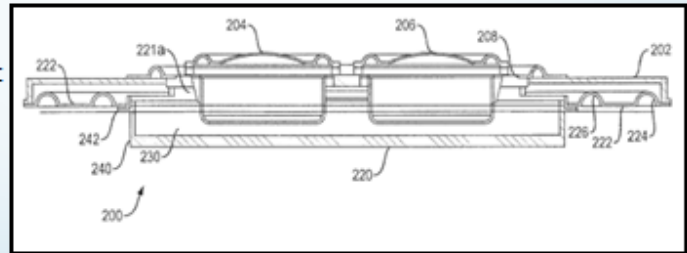

## Synthesis & Designs: Initial Improvements (Design 1)

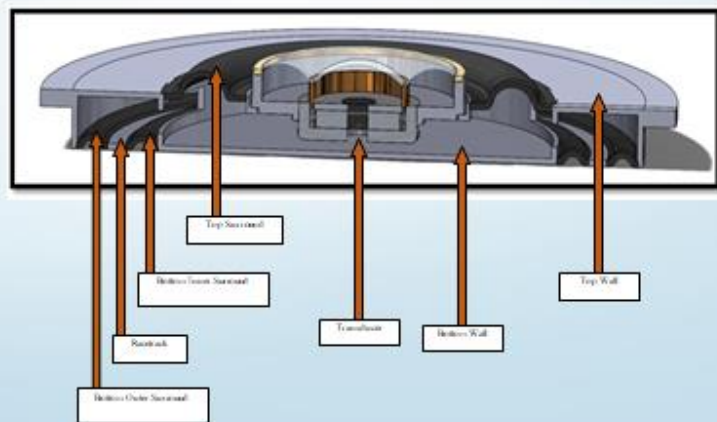

## Synthesis & Designs: Daffodil Transducer Incorporation (Design 2)

- Thickness: 0.24 inches
- Diameter: 5.9 inches
- Top surround thickness: 0.079 inches
- Bottom surrounds thickness: 0.02 inches
- Racetrack thickness: 0.12 inches

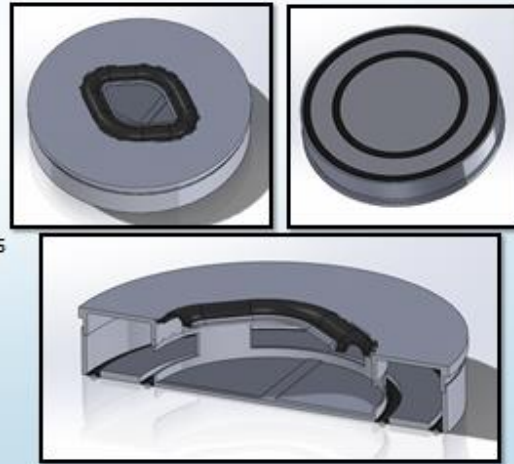

## Synthesis & Designs: Daffodil Transducer Incorporation (Design 3)

- Thickness: 1.08 inches
- Diameter: 4.92 inches
- Resonant frequency: 90 Hz
- Top surround thickness: 0.06 inches
- Bottom surrounds thickness: 0.02 inches
- Racetrack thickness: 0.12 inches
- Curved ribs for structural support

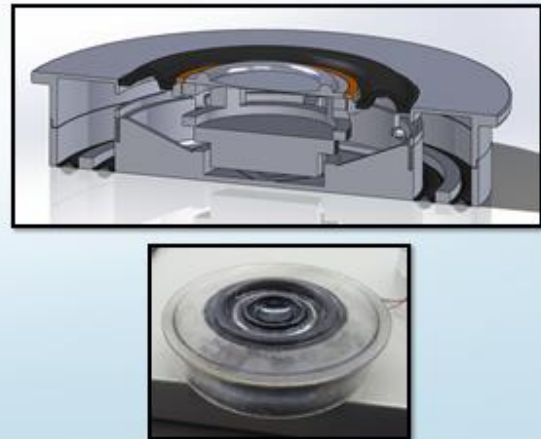

## Synthesis & Designs: Final Moving Magnet Transducer Incorporation (Design 4)

- Thickness: 0.881 inches
- Diameter: 7.32 inches
- Resonant frequency: ~85-90 Hz
- Raised bottom passive radiator
- Top surround thickness: 0.07 inches
- Bottom surrounds thickness: 0.02 inches
- Racetrack thickness: 0.08 inches

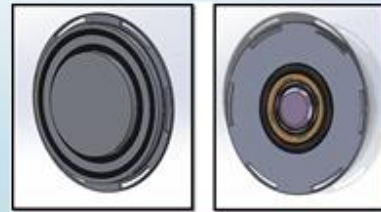
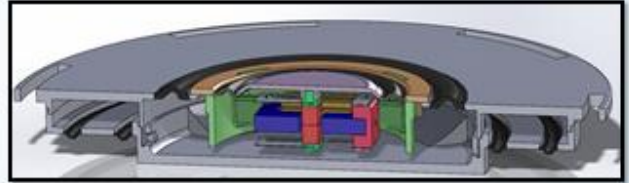

### Assembly

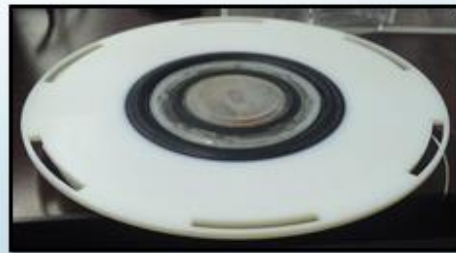

## Synthesis & Designs: Moving Coil Transducer Housing

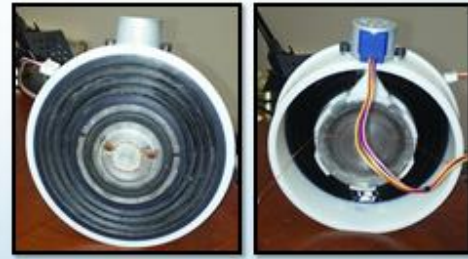
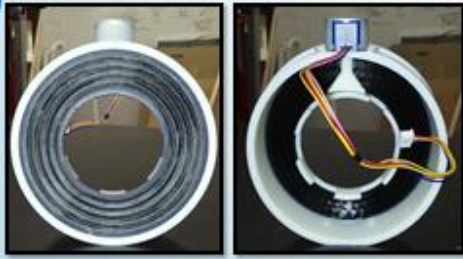

## Testing: Instron

- Used to find material properties of the flexible surround
- Material properties assisted with finding values for Simscape simulations

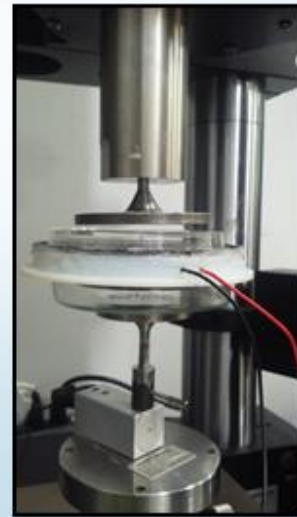

## Testing: Polytec Scanning Vibrometer

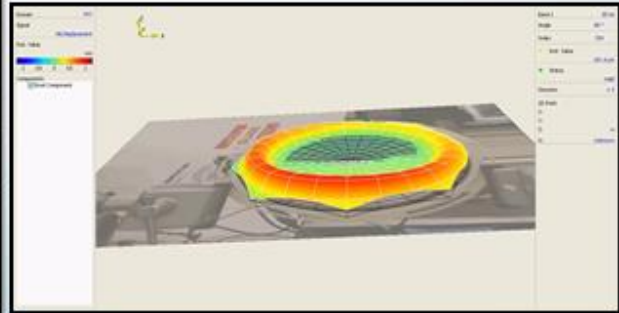
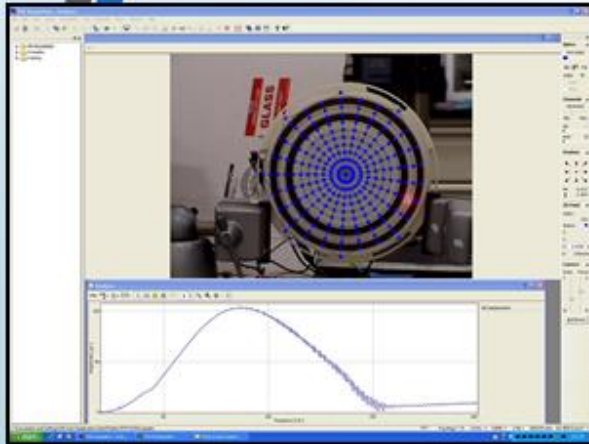

## Analysis: ANSYS

- Used for finding compliance values of various flexible surrounds
- Used for structural analysis of the boxes
- Used for harmonic response of the boxes

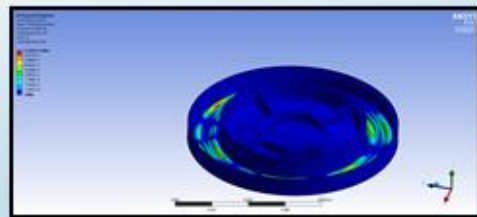
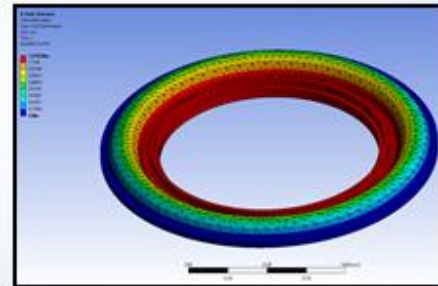

## Analysis: Simscape

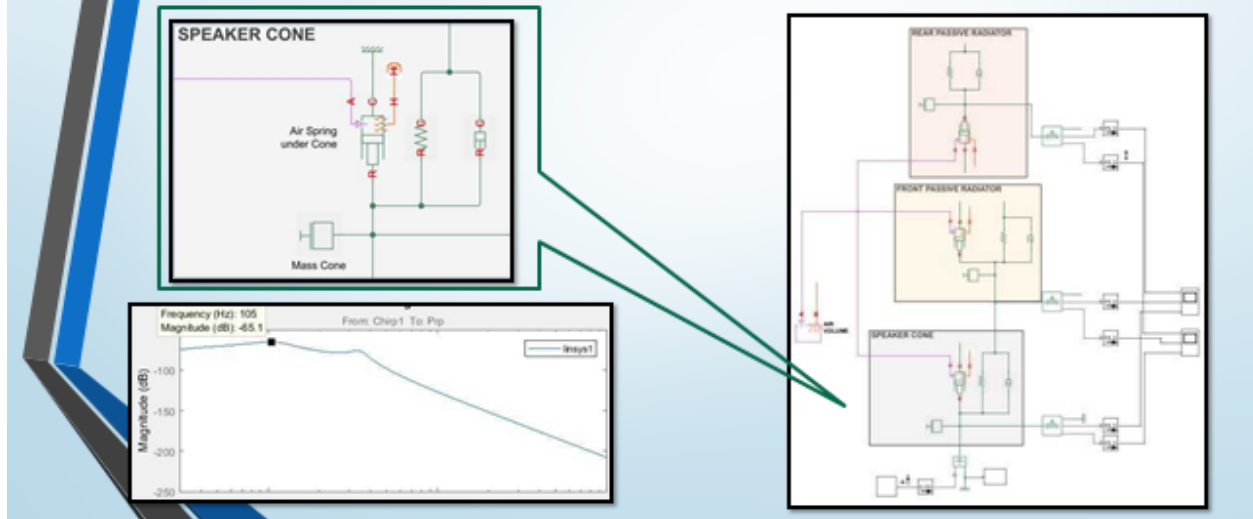

## Results

- Fabricated 6 sealed, raised double passive bass boxes and 2 mechanically rotating housings for use in the low profile, home speaker system
- Incorporated "Moving Magnet" transducers into the six bass boxes
- Achieved a consistent resonant frequency of ~85-90 Hz for the six bass boxes
- The bass boxes were under 0.9 inches in thickness and under 7.5 inches in diameter





## Recommendations

- In future projects, we recommend improving the raised, sealed double passive radiator design (Design 4)
- We recommend improving Simscape models to more accurately simulate acoustic response
- We recommend investigating different flexible materials for the passive radiators in order to reduce damping effects
- We recommend researching manufacturing techniques for scaling-up production



Questions?



Special Thank You to:

- *Our advisor, Joe Stabile, for his encouragement, patience and support in helping us complete this project*
- *Bose Corporation, specifically Guy Torio, Bill Berardi, Jeff Copeland, Binu Oommen, and Dan Sheehan, for the knowledge and advice they provided us*
- *Professor Nikhil Karanjgaokar for access to the Polytec Scanning Vibrometer*
- *Professor Erica Stults for assisting with 3D printing our prototypes with an Objet 260 Connex*
- *Hrachya Kocharyan for teaching us how to use and assisting us with the Polytec Scanning Vibrometer*
- *Pierre-Marie Nigay for assisting with Instron testing*
- *WPI Machine shop for allowing us to use their laser cutter*

# Appendix L: Final Poster for Project Presentation Day at Worcester Polytechnic Institute



# WPI

## The Synthesis and Improvement of a Force Balanced, Sealed Double Passive Radiator Bass Box for a Low Profile Home Speaker System

Nicholas Borsari (ME), Brett Carbonneau (ME), Karim Elsayed (ME), Jeremy Honig (ME)  
Advisor: Joe Stable



### Abstract

Working alongside four other mechanical and electrical engineering teams, this Major Qualifying Project aimed to manufacture a wall-mounted, low profile home speaker system. The main goal of our group was to prototype a force-balanced, sealed, double passive radiator bass box with a low profile and a low frequency response. By conducting background research in parallel with findings taken from the 2016-2017 MQP, "The Synthesis and Design of a Small Speaker System," initial designs were prototyped using additive manufacturing. Simulation software and test equipment were then utilized to tartrate and improve bass response of moving magnet transducers to reach an ideal design. Additionally, mechanically rotating speaker housings were designed for moving coil transducers, to assist in sound steering. The overall work completed in this project was finally incorporated into the wall mounted, low profile home speaker system.

### Synthesis & Designs

**Design 1: Sealed Double Passive Bass Box (SDPBB)**

- Based off of 2016/17 MQP
- First prototype 3d printed in 2 pieces
- Analyzed and improved in order to reference for later designs

**Designs 2 & 3: "Diffused" Sealed Double Passive Bass Boxes (SDPBB)**

- Designed to fit a Duffield transducer
- 2 separate versions designed
- Resonance frequency of ~50 Hz
- Overall thickness of 1.2 inches and 1 inch respectively

**Design 4: Final "Moving Magnet" SDPBB**

- Designed to house a Moving Magnet transducer
- Raised bottom passive radiator
- Purpose is to provide a low to mid range sound output
- Resonance frequency of ~85-90Hz
- Overall thickness of ~0.881 inches

**Design 5: Final "Moving Coil" Flexible Housing**

- Designed to fit a Moving Coil Transducer
- Purpose is to assist in sound steering by mechanically rotating
- Sensors incorporated to rotate based on movement

### Analysis

Finite Element Analysis was performed by using ANSYS to analyze the structural and harmonic response of the sealed double passive bass box designs. Using Simscape, models were created to accurately predict the output of the designed speakers.

**ANSYS**

**Simscape**

### Background

Currently, speaker systems have dominated the consumer market ranging from Bluetooth headsets and ear buds, car audio systems, in-home speakers, and commercially used speakers such as those in theaters. One challenge with developing speakers is the low frequency range. Subwoofers, loud speaker units designed to produce a frequency range between 20 Hz and 200 Hz, can be designed in several ways:

*J. Ahrens, "Electromechanical modeling of the subwoofer enclosure," Laser Team technical paper, 2007.*

Often times however, larger speaker systems produce the best bass whereas smaller speakers sacrifice bass frequency for compactness and transportability. By incorporating 2 passive radiators in a sealed speaker box and by using the transducer as the weight for one of the passive radiators, material, weight, and thickness can be minimized.

*SHIBATA, J. A. (2014). U.S. Patent No. US9723248Z. Washington, DC: U.S. Patent and Trademark Office.*

### Testing

**Instron Testing**

- Recorded deflection (mm) vs. force (N)
- Used to determine and verify material properties (i.e. compliance and E)
- Assisted with simulations

**Poltec Scanning Vibrometer Testing**

- Used to analyze vibrations and resonant frequencies of the double passive bass boxes combined with transducers
- Allows for visualizing small vibrations

### Results & Recommendations

**Results**

- Fabricated 6 sealed, raised double passive bass boxes and 2 mechanically rotating housings for use in the low profile, home speaker system
- Successfully incorporated "Moving Magnet" transducers into the six bass boxes
- Achieved a constant resonant frequency of ~85-90 Hz for the six bass boxes
- The bass boxes were under 0.9 inches in thickness and under 7.5 inches in radius

**Recommendations**

- In future projects, we recommend improving the raised, sealed double passive radiator design (design 4)
- We recommend improving Simscape models to more accurately simulate acoustic response
- We recommend investigating different flexible materials for the passive radiators in order to reduce damping effects
- We recommend researching manufacturing techniques for scaling-up production

### Goals & Objectives

- Research this speaker technology and develop an understanding of how speaker systems work
- Design, fabricate, and evaluate a double passive radiator speaker box that can produce low to mid range bass and that is under one inch in thickness
- Implement and test transducers designed by the other sub-teams into the designed boxes and housings
- Come together collectively (at 5 sub-teams) as a group and develop a final low profile, wall-mounted home speaker system that is capable of producing good sound quality and range, producing good bass, and steering sound

### Acknowledgments

- Our advisor, Joe Stable, for his encouragement, patience and support in helping us complete this project
- Bose Corporation, specifically Guy Torino, Bill Berardi, Jeff Copeland, Binu Oommen, and Dan Sheehan, for the knowledge and advice they provided us
- Professor Erica Sultus for assisting with 3D printing our prototypes with an Objet 260 Connex
- Professor Nikhil Katarangaskar for access to the Poltec Scanning Vibrometer
- Ireshya Kochhar for teaching us how to use and assisting us with the Poltec Scanning Vibrometer
- Pierre-Marie Nigay for assisting with Instron testing
- WPI Machine shop for allowing us to use their laser cutter

## Appendix M: PSpice Installation Tutorial

1. Go to <http://www.orcad.com/buy/try-orcad-for-free>
2. Scroll down and fill out your Download Lite Request (as shown below)

### Download Lite Request

First Name \*

Last Name \*

Email \*

Company/University \*

Job Title \*

- Select a value -

Country \*

United States

Address 1 \*

3. Select the second option in the drop down menu for the Software Requested (as shown below)

Software Requested \*

- Select a value -

- Select a value -

OrCAD 17.2 PCB Designer Lite (All products, download)

OrCAD 17.2 PSpice Designer Lite (Capture / PSpice only, download)

OrCAD 17.2 PCB Designer Lite (All 17.2 products, request DVD)

OrCAD 16.6 PCB Designer Lite (All products, download)

OrCAD 16.6 PSpice Designer Lite (Capture / PSpice only, download)

OrCAD 16.6 PCB Designer Lite (All 16.6 products, request DVD)

- Select a value -

4. Click submit
5. Now you should have received an email with the download link. Click it and download it.
6. Open the zipped folder and double click on the **setup** application (as shown below)

 setup	BMP File	10 KB	No	405 KB	98%	12/22/2015 11:29 PM
 setup	Application	497 KB	No	1,171 KB	58%	3/29/2017 4:38 AM
 setup	Configuration settings	1 KB	No	3 KB	64%	3/29/2017 4:38 AM

7. Install the software by clicking Yes and then Next
8. Select “I accept the terms of the license agreement” then click Next and browse to select the folder for installation

9. Your Installation should start now and it will take about 5-10 minutes, then you should see the window below

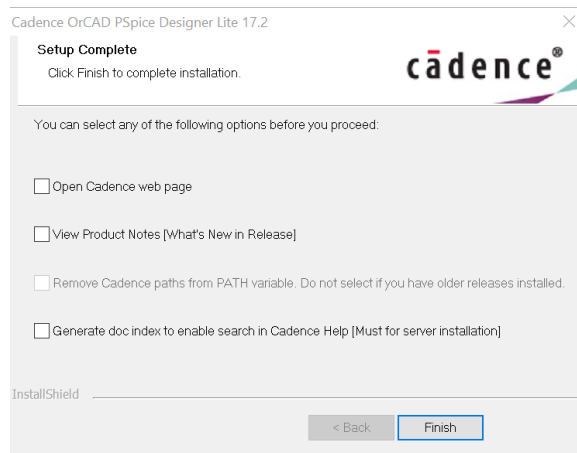

10. Click finish and now you should have it all setup
11. To open PSpice, search for **Capture CIS Lite** and click it
12. To start a new project, select **File → New → Project**. Fill out the project **Name** box, make sure that **Analog or Mixed A/D** button is selected then click **OK**
13. In the next page, make sure to select “Create a blank project” (as shown below) then click **OK**

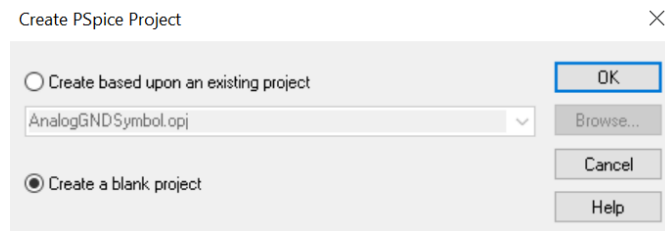

14. Now you should see a blank schematic entry screen as shown below

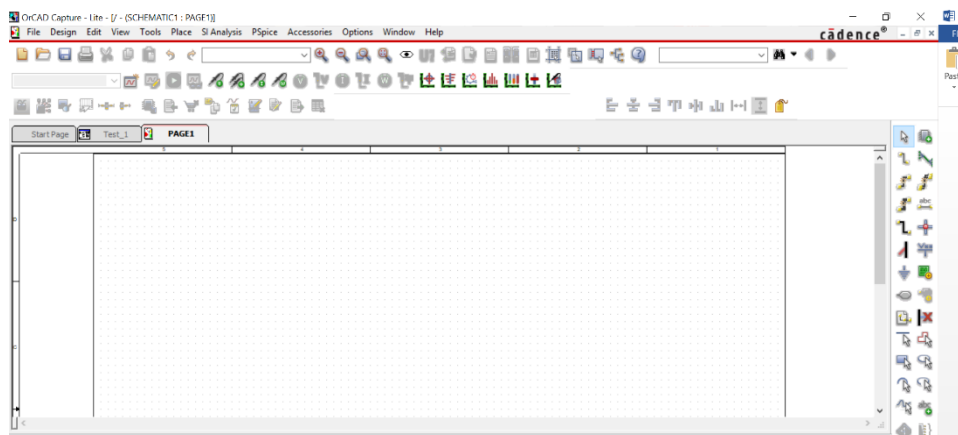

15. Check out this tutorial for an introduction to PSpice schematics and simulation:

[https://engineering.purdue.edu/~ee255/lecturesupp\\_files/PSpice-Tutorial.pdf](https://engineering.purdue.edu/~ee255/lecturesupp_files/PSpice-Tutorial.pdf)

# Authorship

## Nicholas Borsari

Chapter Contributions	Task Contributions
Abstract	<ul style="list-style-type: none"> <li>● Research on speaker systems</li> <li>● Research on Dual Passive Radiator Patent</li> <li>● Designing speaker box models in SolidWorks</li> <li>● Designing mechanically rotated speaker in SolidWorks</li> <li>● Designing overall frame in SolidWorks</li> <li>● Learning how to use ANSYS</li> <li>● Analyzing speaker box models and materials with ANSYS</li> <li>● Submitting CAD files for 3D printing</li> <li>● Assembling the 3D printed prototypes</li> <li>● Testing 3D printed prototypes with the Instron Microtester</li> <li>● Learning how to use the Polytec Scanning Vibrometer</li> <li>● Testing 3D printed prototypes with the Polytec Scanning Vibrometer</li> <li>● Created a standard testing setting for Polytec Scanning Vibrometer</li> <li>● Communicating with the other sub-teams</li> <li>● Assisting other sub-teams with Polytec Scanning Vibrometer testing</li> <li>● Assist with final poster creation and formatting</li> <li>● Report writing/formatting</li> <li>● Ordering and retrieving of materials required for project</li> </ul>
Introduction	
2.1 Overview of speakers	
2.3 Dual Passive Radiator	
2.4 Review of 2016/2017's Major Qualifying Project: <i>The Synthesis and Design of a Small Speaker System</i>	
3.6 Polytec Scanning Vibrometer Testing	
4.2 Daffodil Transducer Incorporation	
4.2.1 Daffodil Box Design 1	
4.2.2 Daffodil Box Design 2	
4.4 Moving Coil Transducer Flexible Housing Incorporation	
4.4.1 Moving Coil Flexible Housing Design 1	
Appendix B	
Appendix D-H	

## Brett Carbonneau

Chapter Contributions	Task Contributions
Abstract	<ul style="list-style-type: none"> <li>● Research on speaker systems</li> <li>● Designing speaker box models in SolidWorks</li> <li>● Learning how to use ANSYS</li> <li>● Analyzing speaker box models and materials with ANSYS</li> <li>● Submitting CAD files for 3D printing</li> <li>● Assembling the 3D printed prototypes</li> <li>● Testing 3D printed prototypes with the Instron Microtester</li> </ul>
Acknowledgements	
Executive Summary	
1: Introduction	
2.1 Overview of Speakers	
2.2 Speaker Enclosures/Boxes	

2.4 Review of 2016/2017's Major Qualifying Project: <i>The Synthesis and Design of a Small Speaker System</i>	<ul style="list-style-type: none"> <li>● Learning how to use the Polytec Scanning Vibrometer</li> <li>● Testing 3D printed prototypes with the Polytec Scanning Vibrometer</li> <li>● Designing and assembling mechanically rotating speakers</li> <li>● Documenting project progress with pictures</li> <li>● Communicating with the other sub-teams</li> <li>● Assisting other sub-teams with Instron testing</li> <li>● Assisting with electrical tasks and electrical wiring of the low profile home speaker system</li> <li>● Assist with final poster creation and formatting</li> <li>● Report writing/formatting</li> </ul>
3.1 Research Objectives	
3.2 Design and Simulation	
3.4 3D Printing	
3.5 Instron Testing	
3.6 Polytec Scanning Vibrometer Testing	
3.7 Communication with other Sub-teams and Redesigning	
3.8 Low Profile Home Speaker System Frame	
4.1 Initial Improvements	
4.2 Daffodil Transducer Incorporation	
4.2.1 Daffodil Box Design 1	
4.2.2 Daffodil Box Design 2	
4.3 Moving Magnet Transducer Incorporation	
4.3.1 Moving Magnet Box Design 1	
4.4 Moving Coil Transducer Flexible Housing Incorporation	
4.4.1 Moving Coil Flexible Housing Design 1	
4.4.2 Moving Coil Flexible Housing Design 2	
4.6 Overall Low Profile Home Speaker System Design	
4.6.2 Speaker System Design 2	
Chapter 5: Recommendations	
Chapter 6: Conclusions	
6.1 Limitations of the Project	
Appendix A through Appendix L	

## Karim Elsayed

Chapter Contributions	Task Contributions
Abstract	<ul style="list-style-type: none"> <li>● Researching speaker system and their electro-mechano-acoustic modeling</li> <li>● Modeling the speaker systems in PSpice</li> <li>● Designing initial speaker box</li> <li>● Designing 3D mount for penny-wise speaker</li> <li>● Testing for the flexible material compliance with the Instron Microtester</li> <li>● Learning how to use ANSYS</li> <li>● Analyzing compliance of surrounds using ANSYS</li> <li>● Analyzing the harmonic response of the entire speaker box with ANSYS</li> <li>● Designing the speaker box for Design 3</li> <li>● Implementing curved ribs to our designs for added support to lower wall</li> <li>● Implementing the twist-lock mechanism for a more-secure fit designs</li> <li>● Improving the a</li> <li>● Submitting CAD files for 3D printing</li> <li>● Assembling the 3D printed prototypes</li> <li>● Communicating with the other sub-teams</li> <li>● Assisting with electrical tasks and electrical wiring of the low profile home speaker system</li> <li>● Assist with final poster creation and formatting</li> <li>● Report-writing/editing</li> </ul>
Acknowledgements	
2.2 Speaker Enclosures/Boxes	
3.3 Computer Modeling (PSpice/Simscape)	
3.3.1 Cadence PSpice	
4.2 Computer Modeling	
4.2.1 PSpice	
Chapter 5: Recommendations	
Chapter 6: Conclusions	
Appendix J: Presentation on How to Use PSpice: Electro-Mechano-Acoustic Modeling	
Appendix M: PSpice Installation Tutorial	

## Jeremy Honig

Chapter Contributions	Task Contributions
Abstract	<ul style="list-style-type: none"> <li>● Researching speaker systems</li> <li>● Designing speaker box models in SolidWorks</li> <li>● Learning how to use the software program Simscape to build simulation models</li> <li>● Using Simscape to model the speaker systems and perform linear analysis, communicating with a MathWorks employee along the way to validate the models</li> <li>● Testing for the flexible material compliance with the Instron Microtester</li> </ul>
Acknowledgements	
Executive Summary	
1: Introduction	
2.1 Overview of Speakers	
2.3 Dual Passive Radiator	
2.4 Review of 2016/2017's Major Qualifying Project: <i>The Synthesis and Design of a Small</i>	

<i>Speaker System</i>	<ul style="list-style-type: none"> <li>● Learning how to use the Polytec Scanning Vibrometer</li> <li>● Learning how to use ANSYS</li> <li>● Analyzing compliance of surrounds using ANSYS</li> <li>● Submitting CAD files for 3D printing</li> <li>● Assembling the 3D printed prototypes</li> <li>● Communicating with the other sub-teams</li> <li>● Assisting with final poster creation and formatting</li> <li>● Report-writing/editing</li> </ul>
3.1 Research Objectives	
3.2 Design and Simulation	
3.3 Computer Modeling (PSpice/Simscape)	
3.3.2 Simscape	
4.2.2 Simscape	
Chapter 5: Recommendations	
Chapter 6: Conclusions	
Appendix I: How to Use Simscape to Model a Speaker System	