



**Problem:** For small-scale microgreen farmers, harvesters are either too expensive or inefficient.

## Background:

Most small farmers use knives or scissors to harvest microgreens. This is inefficient. Efficient equipment costs an exorbitant \$700.

## Solution:

Build an efficient, do-it-yourself harvester at a reasonable cost.

## Harvester specifications:

To promote efficiency:

- Oscillating blade
- Rotating barrel

To reduce cost:

- PVC frame
- 3D printed complex parts
- Common razor blades

## Decision Matrix:

	Scissors/Knives	Quick Cut Greens Harvester	Hamil Microgreen Harvester	Our prototype
Size	5	3	1	4
Cost	5	3	1	4
Portable	5	3	1	3
Easy Assembly	2	2	1	5
Power Use	5	2	1	5
Efficiency	1	3	5	3
Time spent using tool	1	4	5	3
TOTAL	24	16	15	27

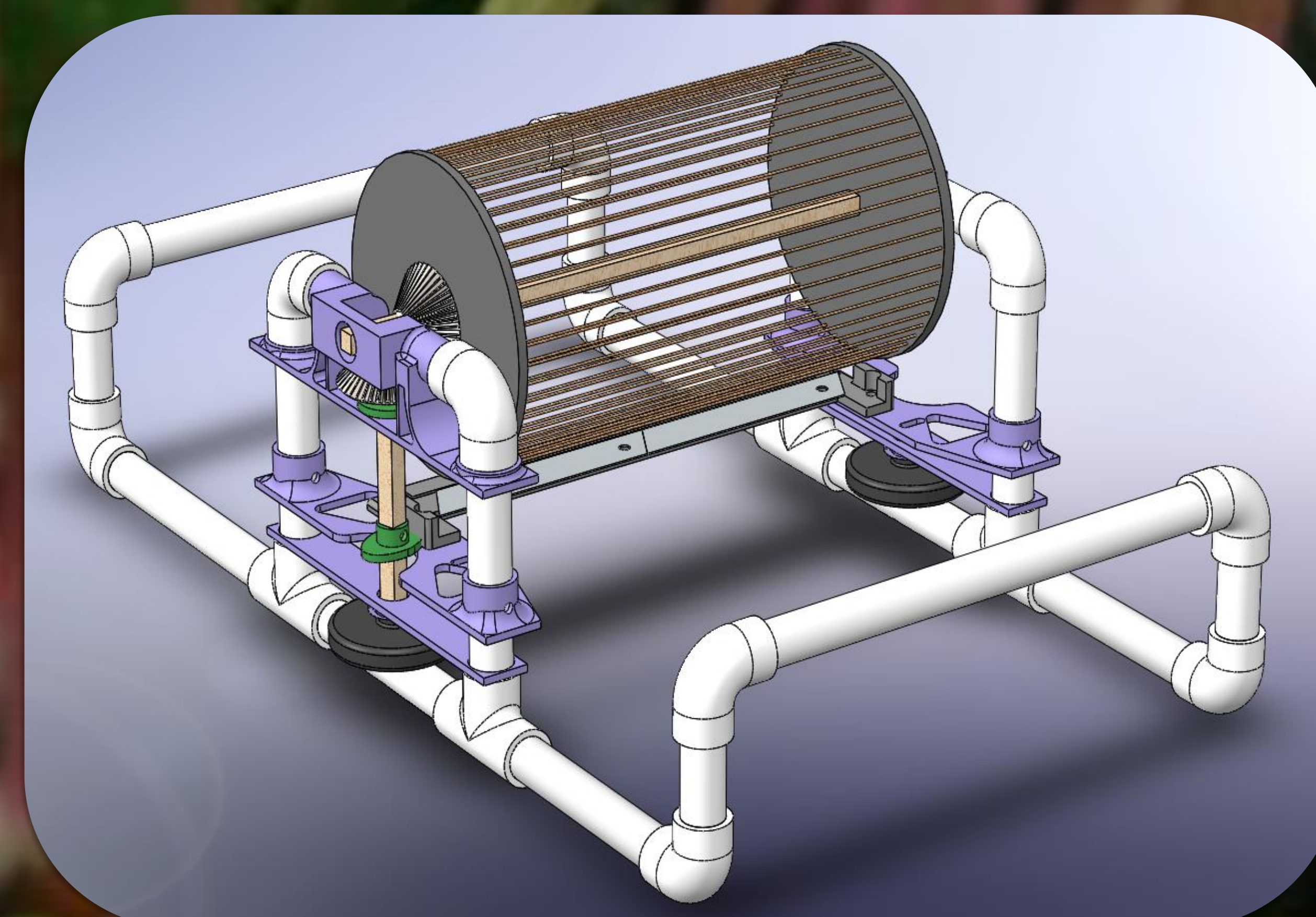

## Final Results:

Our harvester has the highest efficiency per unit cost; 105 trays per hour at \$105.

Harvester Model Efficiency per Unit Cost

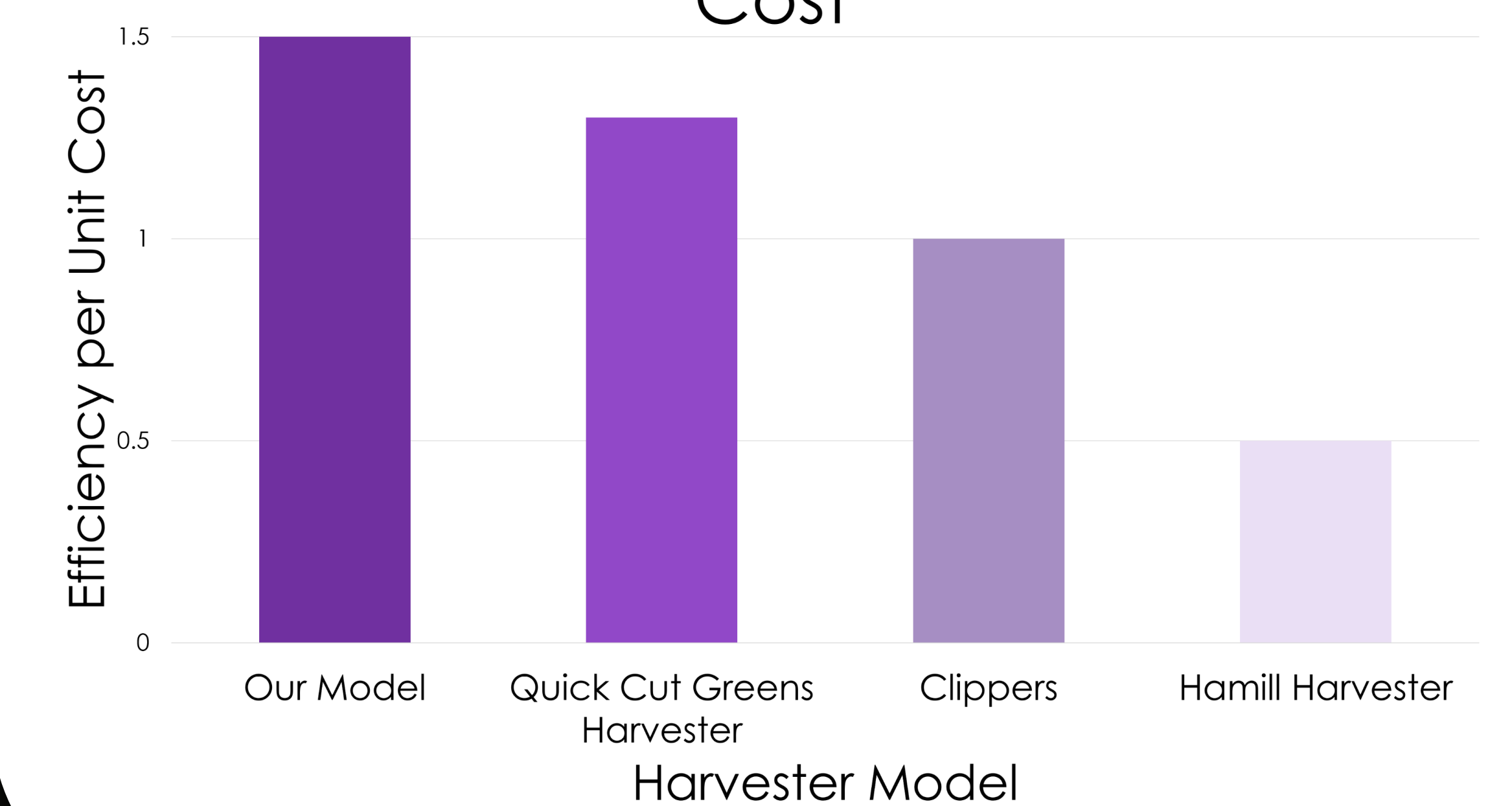

## References:

- C. Stone, C. (2018). Growing 2000 pounds of microgreens per week! Retrieved 10/26/2018, 2018, from <https://www.youtube.com/watch?v=cldQ11ETGYk>
- Dysinger, J. [Farmer's Friend] (Dec 31, 2013). Quick Cut Greens Harvester (Official) [Video File]. Retrieved from [https://www.youtube.com/watch?v=OP1tw5\\_WoLU](https://www.youtube.com/watch?v=OP1tw5_WoLU)
- Guide to Growing Microgreens Indoors. (2015, February 06). Retrieved from <http://grabngrowsoil.com/blog/growing-microgreens-indoors/>
- Microgreens harvester. (2018). Retrieved 10/28/2018, from <https://hamillmachine.ca/products/microgreens-equipment/>
- Quick-cut Greens Harvester - 1503 Replacement Parts. (2018). Retrieved from <https://farmersfriendllc.com/products/harvest/quick-cut-greens-harvester/replacement-parts?model=1503>
- StockUnlimited. (n.d.). You Don't Have To Be A Designer To Get Awesome Visuals. Retrieved from <https://www.stockunlimited.com/similar/1301443.html>