

Improving the Ergonomic Design of Scalpel Handles

May 2010

A Major Qualifying Project Report: Submitted to the faculty of Worcester Polytechnic Institute in partial fulfillment of the requirements for the degree of Bachelor of Science by

Peter Brown

Jennifer Dahlmann

Nicholas Palumbo

1) Scalpel

Dr. Krystyna Gielo-Perczak, Advisor

2) Ergonomic

Prof. Christopher Sotak, Co-Advisor

3) Golden Section

Dr. Raymond Dunn, Co-Advisor

Table of Contents

Authorship	5
Peter Brown	5
Jennifer Dahlmann	5
Nicholas Palumbo	5
Acknowledgements.....	7
Abstract.....	8
Executive Summary.....	9
Table of Figures	10
Table of Tables	11
Chapter 1: Introduction	12
1.1 Anatomy and Anatomical Relations of the Hand	12
1.1.2 Dimensional Relations in Ergonomics.....	14
1.2 Importance	15
1.3 Relevance.....	16
1.4 Current Research.....	17
1.5 Current Products	20
Chapter 2: Literature Review	21
2.1 Patents.....	21
2.1.1 Retractable Scalpel Components.....	21
2.1.2 Adjustable Blades	22
2.1.3 Anatomical.....	23
2.1.4 Scalpel Handle Sleeve.....	24
2.1.4 Ejectable Blade scalpels.....	24
Chapter 3: Project Strategy	25
3.1 Initial Client Statement	25
3.2 Revised Client Statement.....	25
3.3 Defining Objectives	26
3.4 Design Constraints	26
3.5 Project Approach	27
Chapter 4: The Design Process.....	28

4.1 Client Preferences	28
4.1.1 Standard Scalpel.....	29
4.1.2 ErgoCut Scalpel	30
4.1.3 VWR Scalpel	30
4.1.4 WASCO Taxidermy Scalpel.....	31
4.2 Morphological Chart.....	31
4.3 Pairwise Comparison Charts.....	32
4.4 Function/Mean Tree	35
4.5 Conceptual Designs	41
4.5.1 3-3-2 Process.....	41
4.5.2 M2D2	42
4.6 Alternative Designs.....	43
4.6.1 Client feedback on Commercial Alternatives	43
4.6.2 Initial Prototypes	44
4.6.3 Client Feedback on Initial Designs	46
4.6.4 Redesign 1.....	46
4.6.5 Client Feedback on Redesign 1.....	47
4.6.6 Redesign 2.....	47
4.7 Feasibility.....	48
Chapter 5: Design Testing	48
5.1 Scalpel Analysis Utilizing a Force Plate.....	48
5.1.1 Testing Protocol.....	48
5.2 Results.....	50
5.2.1 Introduction of Variables	50
5.3 Analysis.....	52
Chapter 6: Final Design	58
6.1 Final Design Results	58
6.2 Surgeon Survey	60
6.2.1 Comparison to Golden Section Data.....	61
Chapter 7: Future Developments	62
7.1 Ergonomic Factors	62
7.2 Manufacturing.....	63

References.....	64
Glossary	66
Appendix A: Pairwise Comparison Charts	68
Appendix B: Concept Drawings from 3-3-2 Exercises.....	70
Appendix C: M2D2 Poster.....	82
Appendix D: M2D2 PowerPoint Presentation	83
Appendix E – All Alternative Designs	85
Standard Scalpel.....	85
M2D2 Design.....	86
Alternative 1.....	87
Alternative 2.....	88
Alternative 3.....	90
Alternative 4.....	91
Alternative 5.....	92
Redesign 1.....	93
Final Design	94
Appendix F: Testing Questionnaire	95
Appendix G: Testing Data	97
Appendix H: Surgeon Questionnaire	409
Appendix I: Table Relating Handle Dimensions to the Golden Ratio.....	411
Appendix J: Notes from Meeting with Client for Feedback on Designs	412
Commercial Alternatives (date).....	412
M2D2 Design and Alternatives 1-5 (date).....	413
Redesign 1.1-1.4 (date).....	414

Authorship

Peter Brown

1. Executive Summary
2. Importance
3. Relevance
4. Current Research
5. Patents
6. Free Body Diagram
7. Client Preferences
8. Morphological Chart
9. Results
10. Analysis
11. Comparison to Golden Section Data
12. 3-3-2
13. Appendix G: Testing Data

Jennifer Dahlmann

1. Acknowledgements
2. Abstract
3. Anatomy and Anatomical Relations of the Hand
4. Function Means Tree
5. Alternative Designs
6. Feasibility
7. Appendix A: Pairwise Comparison Charts
8. Appendix B: Concept Drawings from 3-3-2 Exercises
9. Appendix E: Prototype Designs
10. Appendix G: Testing Data
11. Appendix I: Table Relating Handle Dimensions to the Golden Ratio

Nicholas Palumbo

1. Current Research
2. Patents
3. Project Strategy

4. Project Approach
5. Morphological Chart
6. M2D2
7. Testing Protocol
8. Surgeon Survey
9. Future Developments
10. Appendix C: M2D2 Poster
11. Appendix D: M2D2 PowerPoint Presentation
12. Appendix F: Testing Questionnaire
13. Appendix H: Surgeon Questionnaire

Acknowledgements

We would like to thank Dr. Raymond Dunn of UMass Medical School's Plastic Surgery department for his sponsorship and support throughout this project. We would also like to thank Dr. Krystyna Gielo-Perczak and Prof. Christopher Sotak from Worcester Polytechnic Institute's Biomedical Engineering department for advising this project. The feedback, advice, and mentorship that these three provided were invaluable to our work.

Abstract

Scalpels are among the most commonly used tools in modern surgery, yet the common design are inadequate for fine and curved incisions. It was also postulated that a more ergonomic design would incorporate the *Golden Section Ratio* within its dimensions. Based on client feedback from five of commercial alternatives, a variety of prototypes were produced. These were further refined through additional client feedback. Data acquired through testing with a force plate indicated that variations of our final design allowed for greater accuracy and precision as exhibited through lower forces in the X- and Y- directions. Our design was further refined and validated through the use of a survey presented to surgeons. Comparing the length of a scalpel blade to the perimeter of scalpel handles at the grip found that designs considered to be more ergonomic more closely approximated the *Golden Section Ratio*.

Executive Summary

The scalpel, used by surgeons around the world for incisions, consists of a handle and blade attachment. The handle portion of this design has not changed for 100 years. It is a flat handle, which makes it less than ideal for circular and elliptical incisions. In these cases a rotation of the scalpel is necessary, which leads to twisting and forced manipulation with a flat handle. In this way a rounded handle would be more beneficial.

Other improvements could also be made. Along with being rounded, the length, grip, and shape of the handle could be manipulated in order to make the handle more ergonomic. Another consideration would be the *golden section ratio*, a ratio that occurs all over the place in nature and could lead to a more ergonomic design. This would compare the blade length to the grip perimeter.

Testing is then necessary to prove that the new scalpel design is superior to all other designs. For this testing we used a force plate, to measure the forces in the x, y and z directions, as well as the moments about these axes. For testing we tested the current scalpel, as well as four alternatives. We also tested several of the prototypes, made using a rapid prototyping machine, including a variation of our final design.

Another consideration was qualitative data. Throughout the project contact was kept with surgeons at UMass Medical School. This helped narrow down the design alternatives to a final design. Then, once near a final design, a questionnaire was applied in order to perfect our final design. Nine different variations of the final design, with varying lengths and widths, were given to surgeons and asked which one was preferred.

From both the testing and questionnaire a final design was decided upon. It has a narrow handle with a bulge in the middle and tapering towards the back, to fit firmly into the hand. A correlation was observed between the preferred designs and the *golden section ratio*. The results from the force plate data are also indicative of a more ergonomic design, showing less moving and manipulation of the scalpel.

Table of Figures

Figure 1: A line split into portions A and B according to the Golden Section	12
Figure 2: Leonardo da Vinci's "Vitruvian Man" modified to exhibit the Golden Section Ratio throughout the human body [1], used here with author consent.....	13
Figure 3: Unity of proportions in the human hand[1], used here with author consent	14
Figure 4: Pencil Scalpel Grip.....	17
Figure 5: Retractable Scalpel Handle.....	22
Figure 6: Adjustable Blade Scalpel[26].....	23
Figure 7: Anatomical Designed Scalpel[30].....	24
Figure 8: Scalpel Sleeve.....	24
Figure 9: Ejectable Bladed Scalpel.....	25
Figure 10: Function/Mean tree main branches.....	36
Figure 11: The branch of the Function/Mean tree for the Sleeve option.....	37
Figure 12: The branch of the Function/Mean tree for the Full Handle option	39
Figure 13: The branch of the Function/Mean tree for the Attachment option.....	40
Figure 14: M2D2 Scalpel Handle Prototype.....	42
Figure 15: Linear, elliptical, and circular incisions were performed during testing	49
Figure 16: The test subject standing during a trial.....	49
Figure 17: A self-healing cutting surface was placed on the AcuSway force plate for testing.....	50
Figure 18: Demonstration of the axis, forces, and moments measured by the force plate.....	50
Figure 19: (Top to Bottom, images are not to scale) Standard Scalpel, Large Handle, Alternative 1, Alternative 3, Alternative 4, Alternative 5, Variation of Final Design.....	52
Figure 20: Forces collected during tests using the standard scalpel in a counterclockwise incision	53
Figure 21: Moments calculated during tests using the standard scalpel in a counterclockwise incision....	54
Figure 22: Moments calculated during tests using Alternative 1 and Alternative 4 in a counterclockwise incision.....	55
Figure 23: Moments calculated during tests using the large handle scalpel and Alternative 3 in a counterclockwise incision.....	56
Figure 24: Moments calculated during tests using the largehandle scalpel and Alternative 5 in a counterclockwise incision.....	57
Figure 25: Comparison of Forces and Moments between the Standard Scalpel and a variation of the final design.....	59
Figure 26: Peak force and moment values for the standard scalpel and a variation of the final design	60
Figure 27: The ratio between the handle perimeter and the blade length was compared to the Golden Section Ratio.....	62

Table of Tables

Table 1: Description of current Scalpel Designs.....	28
Table 2-Morphological Chart.....	Error! Bookmark not defined.

Chapter 1: Introduction

1.1 Anatomy and Anatomical Relations of the Hand

The field of ergonomics involves the design of objects and environmental aspects to increase the productivity and comfort of the user. Within the context of scalpel handle design this requires an understanding of hand anatomy and the interface between the hand and the scalpel handle. Anatomically, the wrist and hand are comprised of 27 bones, with 8 carpal bones making up the wrist, 5 metacarpals forming the main body of the hand, and 14 phalanges in the fingers and thumb. Three nerves control the multitude of muscles required for the dexterity and range of motion required. These three nerves each carry signals for both muscle activation and sensory input [2].

Recent studies have also found that the Golden Section Ratio is associated with designs that are considered to be more ergonomic. A line can be broken into two sections A and B, as shown in Figure 1, such that the ratio of A to B is the same as the ratio of B to the whole line, or

$$A/B = B/(A+B).$$

If the length of the whole line (A+B) is set equal to 1,

$$(1-B)/B = B/1$$

$$B^2+B-1 = 0$$

$$B = 0.61803\dots$$

Thus the ratio of B to the whole is 0.618, or the Golden Section [1]. This irrational constant and its inverse, 1.618, are both considered to be the Golden Section. Leonardo da Vinci's "Vitruvian Man" has been modified to exhibit how the Golden Section Ratio appears throughout the human form in the relative sizes of adjacent parts, as can be seen in Figure 2.

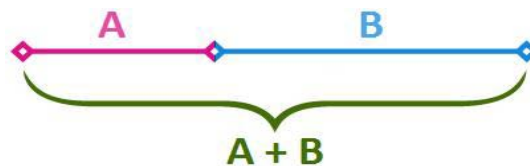

Figure 1: A line split into portions A and B according to the Golden Section.

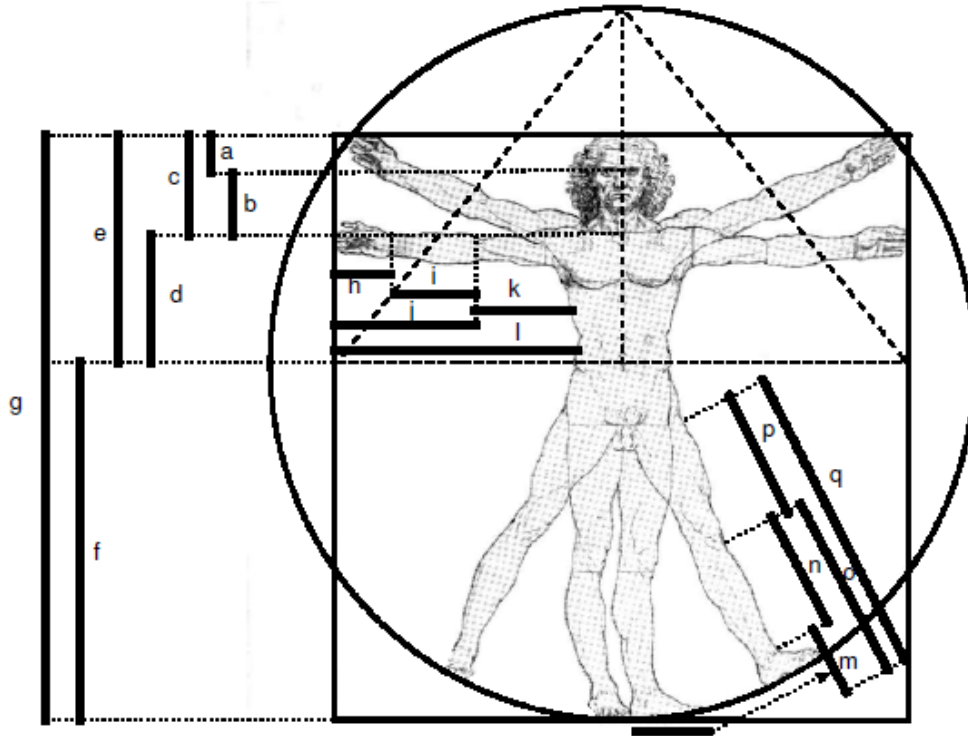

Figure 2: Leonardo da Vinci's "Vitruvian Man" modified to exhibit the Golden Section Ratio throughout the human body [1], used here with author consent.

The *Golden Section* is also exhibited between adjacent segments of the hand, as can be seen in Figure 3. This image shows the x-ray image of an adult male hand. The right side of the figure shows the length of each bone and the width of the joint. It can be seen that not only does each bone approximate the *Golden Section* with its neighbor, but this ratio is also approximated between the bone length and the width of the proximal joint associated with it. The harmonic waves overlaid on the middle finger illustrate the unity of these proportions.

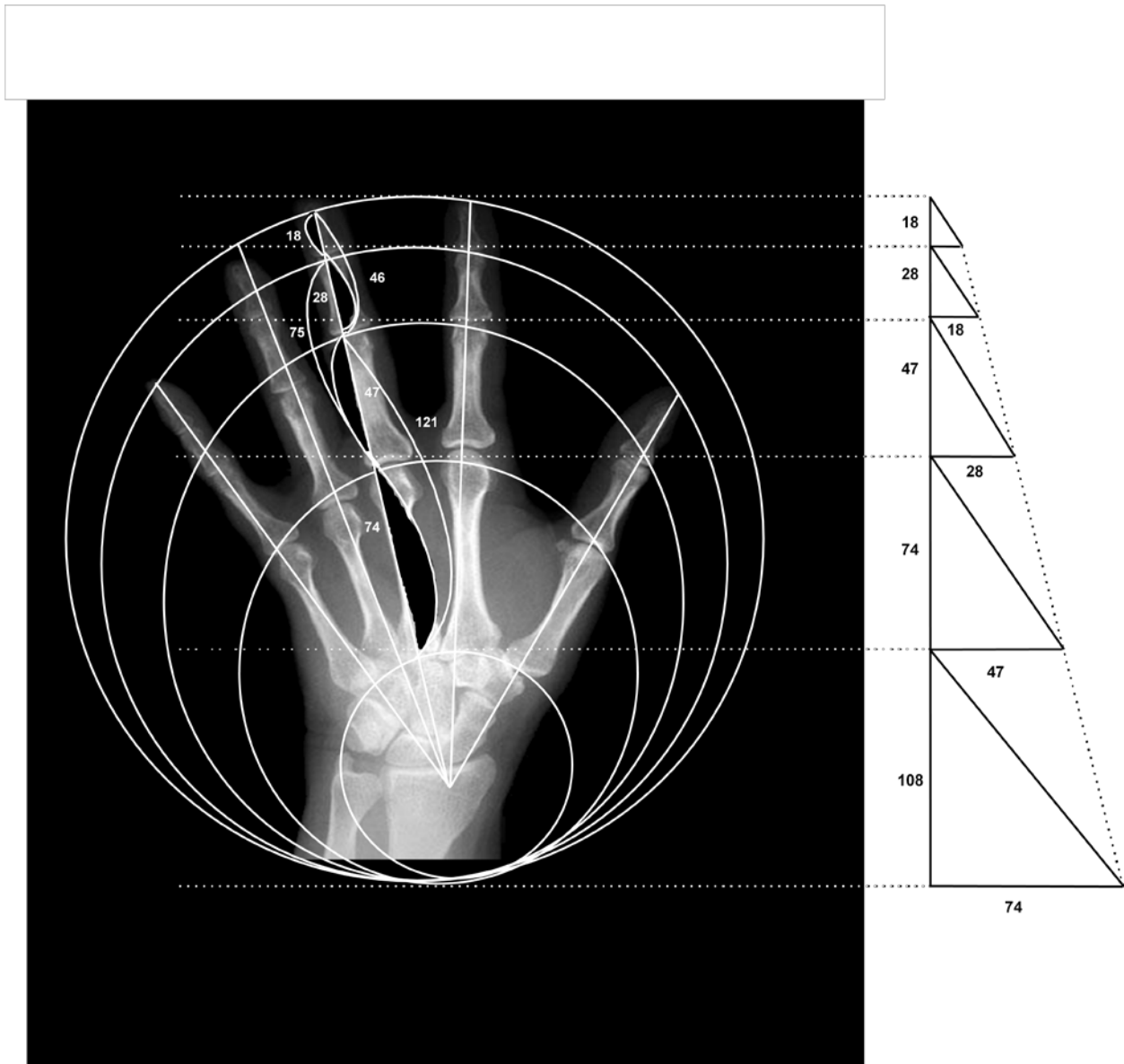

Figure 3: Unity of proportions in the human hand [1], used here with author consent.

1.1.2 Dimensional Relations in Ergonomics

Research is currently being conducted on the relationship between the dimensions of relevant body segments and the dimensions for tools and environmental aspects that are considered most comfortable. A notable paper by Gielo-Perczak discusses the preferred designs for staircases and knives. Data was used from a 1990 study by Irvine et al[4] seeking to find the stair height and depth most preferred and how this is related to body dimensions. Further analysis of these results showed that the most widely desired stair dimensions approximated a Golden Rectangle. In addition, it was found that the ratio of the foot length to the height of the stair roughly approximated the Golden Ratio [1]. In another

study conducted by Hsiang et. al[5], there was an attempt to identify a better knife design based on grip size, angle between the handle and the blade, blade length, and blade height at the middle of the blade. Further analysis of this data by Gielo-Perczak revealed that the knife found most desirable by the test subjects exhibits a close approximation of the Golden Ratio when the handle diameter is compared to the blade length [1]. As this work shows, applying Golden Section elements to designs can have a very positive effect on the ergonomics of the device or environmental element being created.

1.2 Importance

One of the most common surgeries performed by plastic surgeons is the removal of skin lesions. This procedure is performed by cutting an ellipse around the lesion, usually removing additional skin in case the lesion is cancerous. After the tissue is removed, the excision is sutured together, leaving a small scar. Ideally, this procedure would not leave a noticeable scar on the patient. Scar formation is reduced by cutting the skin at an angle creating a mirrored “V” incision. The tops of each side of the “V” are then sutured together. Unfortunately, with the scalpels that are currently available, creating a perfectly mirrored incision is not a simple task[6].

The clients for this project, the surgeons at UMass, wish to have a comfortable, ergonomic scalpel. The common scalpel used at UMass is ill equipped to create the curved incisions necessary for this procedure. The surgeons also commented about lack of grip, which can result in the scalpel slipping. The handle of the blade is simply not as advanced as surgeons would like it to be.

Surprisingly, few patents exist to improve scalpels. These scalpels are presented in the patent section of this paper. All of these products have failed in that, whether because of the cost, the comfort, the practicality, or usability, they have not been widely produced.

For the past one hundred years the most common scalpel has been the Bard Parker scalpel. This scalpel, made with a metal or plastic handle, allows several different types of blades to be attached to it. Depending on the type of surgery and what level of precision is necessary, a surgeon can attach a different blade to the scalpel handle. These scalpels are produced both as a disposable single-use item and as a product made to be sterilized and reused. In general, the scalpels used at UMass are metal scalpels that are sterilized before surgery[7].

The UMass scalpels have three main benefits. The first and second benefits are that they can be sterilized and are relatively inexpensive to purchase. The most important benefit, and the difficulty this project must overcome, is that surgeons have been using this product for a long time and have become accustomed to it. The scalpel handle that will be designed for this project must be fabricated in such a

way that it pleases the surgeons and has an equal value compared to the price of current scalpel handles[8].

1.3 Relevance

According to the national center for health statistics, 41.3 million inpatient and 31.5 million outpatient surgeries were performed in 1999[9]. The commonality between the surgeries is use of a Bard Parker scalpel. This scalpel, made of stainless steel, has a completely flat handle with very little grip and does not provide the precise control surgeons desire when performing surgeries [7].

With the current scalpels available on the market the surgeon is forced to compensate for the poor design of the scalpel. Not every surgery involves cutting straight lines, and it is during curved incisions that the problems with a scalpel are easily seen. A good example of this is when surgeons remove skin lesions. Usually the removal of warts and possibly cancerous lumps is an outpatient procedure performed with a local anesthetic. The surgeon cuts an ellipse around the lesion and excises it. If the lesion is thought to be cancerous, then a large area of tissue is removed, in order to make sure all of the cancerous cells are removed [6]. The surgeons in this case have to cut an ellipse or a curved incision, which is not easily performed with a conventional scalpel. Because the handle is flat, the surgeon cannot simply twist the scalpel and are forced to completely reorient their arm to make the cut[10].

When using the scalpel, the surgeon grips it in whichever way they feel is most comfortable. Due to the demands of various surgical procedures and the level of compensation needed when working with current handle designs, there are several ways to hold the scalpel. The two most common grip styles are the pencil grip, seen in Figure 4, and the knife grip. With the pencil grip, the surgeon holds the scalpel as though it were a pen or pencil with the scalpel held by the forefinger, middle finger, and thumb. The end of the handle distal from the blade rests in the “first inter digital area.” This grip is used for fine, delicate work. With the knife grip, the scalpel gripped between the thumb and middle finger with the fore finger applying a slight pressure on top, similar to the way a dinner knife is held. This type of grip is primarily used for longer incisions where fine precision is of less importance [10].

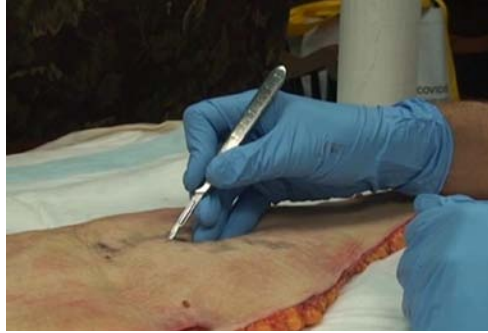

Figure 4: Pencil Scalpel Grip.

There are many alternative designs for scalpels. These designs can be placed into several categories. There are retractable, adjustable, and “ergonomic” scalpels. There are also sleeves that can cover the handle of traditional scalpels. All of these designs, for one reason or another, have not been widely implemented and the main scalpel used UMass is still the Bard Parker type scalpel.

In many ways, surgery has not changed for almost a hundred years. With the many changes in manufacturing and use of polymers available today, many improvements to the current scalpel are possible. Surgeons should be provided with a tool that is designed for the task at hand, not one that forces them to compensate for design inadequacies.

1.4 Current Research

Although there are not significant studies on designing an ergonomic scalpel, there are several on creating ergonomic tools that are similar to scalpels. For example, an ergonomic pen or knife has been developed. When creating these tools, the authors performed a comprehensive study into the ergonomics of the product. Most of these studies can be used to better understand what can be incorporated for scalpel design.

One study investigated the measurement of grip forces and applied moments when using a hand tool. The hand tools ranged from a screwdriver to a knife. The study mainly focused on a knife but implied that, with some small variations, it could be used for any hand tool. This study hoped to use their knowledge to prevent hand-tool-related injuries like upper extremity muscular skeletal disorder. Although there have been previous studies using force plates or direct instrumentation of hand tools, they were described as inefficient due to the lack of information found between the hand tool interface. This study wishes to create a system that can resolve grip forces and applied moments produced using non-powered, single-handed tools. They also did an evaluation of the utility of the proposed device when under work-place simulations[11].

To do this the investigators created a handle of sorts that was fitted with gauges to measure torque and other relevant forces. The study then simulated meat cutting by having people cut clay of varying thicknesses with a knife that was fitted with the handle. They found that the device provided accurate measurements of forces and moments. These measurements, along with an understanding of the biomechanical models, could be used to create a highly ergonomic design. Although the handle was only used with a knife, the handle could be fixed to similar things as well [11].

Another study evaluated the effects of pen design on writing and drawing performance. Writing with a pen is actually very similar to using a scalpel. The main way to hold a scalpel is like a pen. The study began by going over all of the previous research on pens. Pen comfort depends on many things. For example, the type of pen, fountain or ballpoint, affects the pressure necessary and the speed of writing. The writers hand also affects the type of pen wanted. It was found that a smaller handed person generally preferred a smaller pen. Depending on the grip of the pen, different pressures can be placed on the pen. This study focused on the evaluation of different weights, shapes, and diameters and there effects on pen performance. The performance was based on the speed, errors, and what the subject preference [12].

To do this, the study created several different pens of varying diameters, shapes and weights and then had participants write or draw with them. The participants first traced mazes. An interesting finding was that errors increased with increased pen size. This increase was not really statistically significant but it correlates with the increase in speed that was found with increased pen size. The participants also used differently shaped pens to write. They measured the speed of writing, as well as asking the participants how they liked the pen. They found that comfort was directly related to writing ability. The speed interestingly did not change. Even the most uncomfortable pens were used at the same speed [12].

Their final findings explain much about pen design. For the first experiment they found that hexagonal cross sections are the worst shape for accuracy, compared to circular and elliptical. Errors also increased with pen size, although speed decreased with increasing pen size. The second experiment showed that pen grips should be close to circular based on comfort. Also, a pen should not have a large diameter or weigh too much. The study follows their discussion describing that although writing speed was not found to be affected by the pen size, over long term use it may have an effect[12].

This MQP addresses the issue of non-ergonomically designed scalpel handles. To gain a better understanding of products that are designed to interface with a user's hand, computer based pens were researched. Previous research has been conducted on designing pens that work with computer screens which reduce hand fatigue and increase writing precision [13-15].

One such study wanted to improve performance and reduce injury by making the touch pens handle more ergonomic. They first observed the characteristics of current touch pens, then designed a new touch pen, and compared the new pen to the old pen[15].

To do this study the researchers enrolled people with touch pen experience to write like they usually do and video recorded it. They then analyzed the footage to find the most common postures and writing styles. For example, slightly less than half of the people elevated their elbows while slightly more than one half rested them on the table. They found that the grip commonly used was the tripod grip where the pen is held between three fingers, the thumb, the forefinger and the middle finger. They designed a brace that sticks off the pen and goes between the thumb and the hand[15].

The initial test had people writing and pointing and clicking with the pen. The number of errors differed depending on which task was being performed but the speed did not. Between the new pen brace they designed and the original touch pen, fewer errors occurred in both the writing and pointing and clicking. This shows greater stability. Another interesting finding was that the users did not touch the screen or rest there hand when using the new brace. In conclusion, the brace increased hand stability, reduced hand fatigue, and was adjustable so the user could adjust it to whatever felt most comfortable [15].

Two studies other studies found that ideal pen length and diameter were found to be 110-140mm and 11mm respectively. Further conclusions were that the diameter of the pen was more significant in increasing writing quality compared to length of pen. The importance of pen length is that it should be comfortable, meaning not excessively long or excessively short, for the user and touch the palm of the hand. This adds support and increases the stability when writing. Variances in length had minimal effect once the palm offered support for writing [14].

In another study, the use of an attachable support for computer-based pens was researched. These attachments clipped onto existing pens and offered the user added support to prevent wrist flexion. Ball-shaped and “natural” shaped attachments were studied. The natural attachment was contoured to the shape of the palm when using a writing utensil. Testing demonstrated that both shapes helped to align the wrist but the naturally-shaped attachment, which fit the inner palm, proved to increase writing accuracy. Different sizes of attachments were also studied and the researchers concluded that the smaller-sized brace, which still contracted the users’ inner palm, was the most effective design. The study commented that the naturally-shaped attachment fit the user better and the smaller-sized attachment increased pen control [13].

All of these studies can be utilized in the design of a scalpel. Although the studies measured different objects, such as pens and knives, the basic findings can be used to enhance the design of the scalpel. Using these studies, there is a way to measure forces in a hand-held instrument as well as data found for a knife, which is very similar to a scalpel[11]. There is also detailed research in the ergonomics of pens, from regular to touch screen pens. This knowledge is important in that holding a scalpel and cutting with a scalpel is very similar to writing with a pen [12-15]. Extensive research has been done on the ergonomics of pens and knives which can be used for the design of an ergonomic scalpel.

1.5 Current Products

The clients, UMass surgeons, have identified the problem that available scalpel handles are uncomfortable to use for mirrored incisions performed for small lesion removal. The scalpels used by the surgeons are thin with flat edges which, when used to make a counterclockwise incision (for right-handed surgeons), are awkward to hold and limit the surgeon's control. Many of the products available to surgeons from distributors such as VWR and Fisher Scientific do not address this problem and these vendors sell scalpel handles which are no different than the ones used by UMass surgeons [16, 17].

Hospitals are generally resistant to replacing existing equipment with more state-of-the-art designs, particularly when there is an associated price increase. As such, most uniquely-shaped scalpels designed to be ergonomic are disposable designs created from molded plastic and are intended more for use in animal surgery than in procedures on humans. One of the few products available that claims to be ergonomic and for the use in human surgery is the Canica Standard Scalpel. Unlike most scalpel handles on the market, the Canica model is contoured to better fit the hand and has grooves at the bottom of the handle for added grip. A safety feature of the handle is a button that ejects the scalpel blade [18].

To address the limited comfort and control of flat scalpel handles, sleeves are available which cover the handle, increasing the gripping surface area. The sleeves provide a larger area for the surgeon to hold and are intended to offer greater control over the instrument. Sleeves can be molded to fit the hand in a more ergonomic manner, compared to the traditional straight scalpel handle[16, 17].

Retractable blades are another feature of some currently available products. Accidental injury caused by exposed blades are said to be reduced if the scalpel blade can be retracted into the handle when not in use [16, 17]. Although it can offer a solution to a potential injury, the client described that retractable blades are not used during UMass surgeries and will not be adopted for future procedures.

Chapter 2: Literature Review

2.1 Patents

Typical scalpels consist of a handle which the surgeon holds and a blade that cuts tissue. The blades are generally interchangeable so few variances of scalpel handles are needed for a surgery. There are currently numerous patents for scalpels, many of which are novel handle designs and blade to handle interfaces. Another area of patents involving scalpels is sleeves that encompass the handle. These sleeves are intended to provide the surgeon with a more comfortable and better surface to grip. The last area of scalpel patents examined is scalpels that attempt to create a safe mechanism for removing scalpel blades. We examined a total of 17 patents in the category of scalpel design.

2.1.1 Retractable Scalpel Components

Safety measures are taken into account when designing scalpels and many scalpels have patented retractable mechanisms to prevent accidental injuries due to the blade, Figure 5. Preventing general puncture wounds and the spread of blood-borne diseases are two main reasons for having a blade retract when not in use. Once the blade cuts through tissue and is no longer sterile, there is a possibility of disease transmission if the scalpel is not handled properly. Patents involving retractable blades have a slider protruding out from the scalpel handle which is used to retract the blade into the handle. Sliders can be found on the top or side of the scalpel handle. The variation utilizing a slider on the side of the scalpel handle is often found on the left side, to be used by the surgeon's right hand and thumb. The inherent problem with this design is the functionality of the slider when used by a left-handed surgeon. It is not practical for a left-handed surgeon to switch hands or to rotate the scalpel in order to retract the blade. Regardless of the placement of the slider, many retractable blade scalpels have a locking slider. Locking sliders act as safety mechanisms for retractable blades where locking the slider prevents accidental retraction or ejection of the scalpel blade. Aside from having a stationary, retractable scalpel blade, there are also scalpels with stationary blades and retractable handles. This allows for the scalpel blade to be permanently fixed to the scalpel handle, without any worry that the scalpel blade will move during use [7, 19-23].

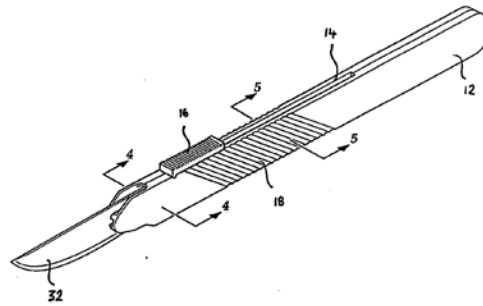

Figure 5: Retractable Scalpel Handle.

Another area of patented retractable scalpel blades is the use of the slider as a means to have an accurate cut depth. These types of scalpels have indicators on the handle of the scalpel where the slider corresponds to the blade depth in relation to the handle. This provides an easy means to cut tissue at an appropriate depth [19-23].

Additional safety aspects of scalpels with retractable blades are in the inclusion of an indicator that displays when the blade has been removed from the handle and is no longer sterile. As aforementioned, one of the main concerns when using a scalpel is preventing disease transmission. Once the scalpel blade is no longer sterile then foreign micro bodies can attach themselves to the blade. Using a non-sterile scalpel blade can cause inflammation and prevent the dissected tissue from healing properly [19-23].

Most retractable blade scalpels suffer from the fact that it is very difficult to replace the blade in the scalpel. Generally, one has to take the entire handle apart in order to take out the non-sterile blade and put in a sterile one. These scalpel blades are also different in weight and shape than the conventional scalpels. The shape change due to the adjustable slider may force the surgeon to grip the scalpel in an unnatural way [7].

2.1.2 Adjustable Blades

Scalpels, particularly used for tight and curved incisions such as during dental procedures, require the surgeon to have a variety of scalpels with different angled blades. This allows for the surgeon to cut the required site with relative ease and better precision. The problem experienced by surgeons who use a variety of blades and handles for a single procedure is the need to have an abundant amount of each. It is not always practical or feasible for a surgeon to have every angle which can correspond to a particular cut for a particular patient. There is also the issue that, of the blades and scalpels the surgeon uses, there will not be a perfect match for the patient. To solve this problem adjustable blade scalpels have been patented [7, 19, 24-26].

Patents of adjustable blade scalpels have a free moving blade that can be adjusted to a desired angle and locked into place. The blade can adjust between the flat, horizontal position of a typical scalpel and perpendicular to the scalpel handle. One such scalpel blade was fitted to the handle by means of a ball and socket joint, which can be seen in Figure 6, where the blade could be locked by a sliding mechanism. Another scalpel design had a lever locking mechanism where a lever could be raised to adjust the blade and lowered to lock it into place. Both patents allow the surgeon to permanently change the angle of the blade with respect to the scalpel handle, and lock them into place [7, 19, 24-26].



Figure 6: Adjustable Blade Scalpel[26].

2.1.3 Anatomical

Scalpels patents under the section “Anatomical” are ones that have been designed specifically for the user’s hand. These blades are visually different than typical scalpel handles because they are not the standard flat, thin body with a blade attached at the end. These scalpel handles were designed more for the curvature of the surgeon’s hand. Such patents include scalpels specifically for right handed and left handed surgeons [27, 28].

One such anatomical scalpel has a handle that is slightly curved to rest lightly on the hand of the surgeon and balanced so that the finger of the surgeon can act as a fulcrum for the handle. The handle is weighted in such a way as to right itself in the surgeon’s hand so the blade is perpendicular to the cutting surface [29].

Another anatomical scalpel is designed to the curvature of the forefinger, Figure 7. Visually, this is a much more curved handled than a typical scalpel. Also, the scalpel contains an additional curved piece directly under the top, creating a hole for the surgeons thumb. The scalpel is designed to be held in a variety of hand positions, for different surgical procedures [30].

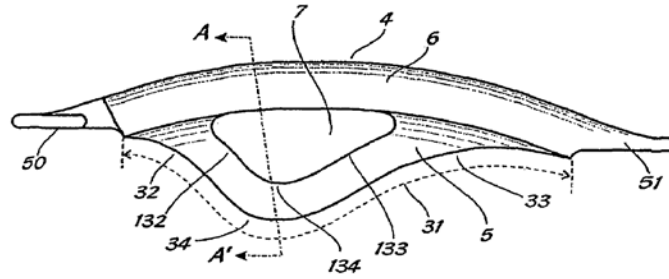

Figure 7: Anatomical Designed Scalpel[30].

2.1.4 Scalpel Handle Sleeve

Rather than redesigning a scalpel handle to make it more user friendly for the surgeon, sleeves are designed to be placed over the handle, allowing for a more comfortable and secure grip. One such sleeve design completely encompasses the scalpel handle, greatly increasing the gripping area (Figure 8). This allows a surgeon to hold the traditionally flat scalpel handle in a more secure manner. When a surgeon is making an incision at an awkward cutting angle, the scalpel is less likely to roll in the surgeons hand with the addition of the sleeve. This creates a scalpel handle that is more precise compared to traditional flat scalpels [31].

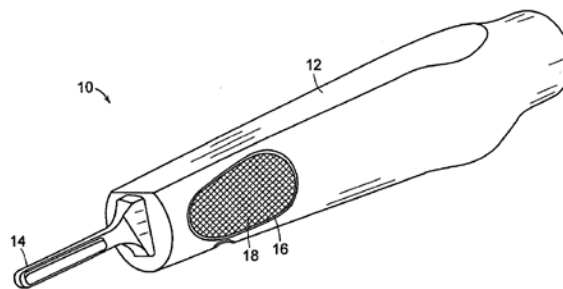

Figure 8: Scalpel Sleeve.

Another sleeve design is a textured grip that slides over the scalpel handle, almost identical to grips found on modern writing utensils. This type of grip aides in the surgeons ability to hold onto the scalpel for micro procedures and also allows the surgeon to use less force when gripping the scalpel handle. The better control over the scalpel reduces hand fatigue and increases the precision of the surgeon [32].

2.1.4 Ejectable Blade scalpels

Scalpel handles that are outfitted with a mechanical means to eject the scalpel blade aid in blade removal. This type of scalpel negates the need for a person to remove the scalpel blade with forceps.

Accidental cuts could result in the transmission of dangerous diseases if the scalpel blades are removed improperly [23].

This type of scalpel utilizes a device that is part of the scalpel handle to release the blade, Figure 9. Although devices already exist to remove scalpel blades, this device is incorporated onto the scalpel, thereby reducing the amount of devices in the lab, as well as allowing for the blade to be removed easily, with one hand. On the scalpel handle is a blade release slide element that slides down and hooks under the scalpel blade, effectively releasing it [33].

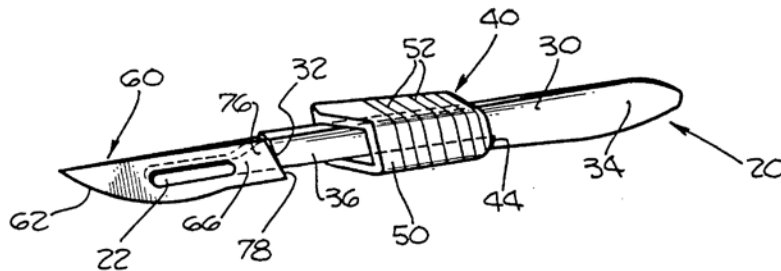

Figure 9: Ejectable Bladed Scalpel [33].

Chapter 3: Project Strategy

3.1 Initial Client Statement

Design, prototype, and test a novel scalpel handle and sleeve which would allow more controlled and precise use by the surgeon.

3.2 Revised Client Statement

Design, create, and test prototypes of scalpels primarily for the use of small lesion removal. The prototypes should not have retractable parts or have an adjustable blade. The scalpel can either be a new design or a modification of existing scalpels used by surgeons at UMass. The design will need to increase the comfort, control, and precision the surgeon has when creating incisions, particularly ones that are symmetrical. The design should also prevent the scalpel from slipping when used by the surgeon during a procedure. The materials used for the design will need to be able to withstand sterilization processes and typical wear associated with surgical procedures. Minimizing cost while considering the concerns and priorities of all stakeholders is a primary goal. Surgeons need to be confident in the surgical tools they use, hospital administrators are concerned with cost effectiveness, and the operating room nurses will need a device they can handle safely and efficiently to prepare for surgery. Reducing the cost of the

design will help to create a product that can be incorporated into future surgical procedures and justify the purchase of a new and novel surgical cutting tool.

3.3 Defining Objectives

The main goal of the project is to create a prototype that improves upon the scalpel design currently used by UMass surgeons. The objectives of the prototype are to increase the comfort, precision, and control the surgeon has over the scalpel during small lesion removal.

The prototype should increase the comfort over current used scalpels by limiting the need for awkward hand movements when making symmetrical, curved incisions. As the perception of comfort is subjective, this will be difficult to evaluate. The balance, weight, and dimensions of the prototypes will need to be altered based on feedback by the surgeons.

Precise incisions are essential for the healthy and aesthetic recovery of small lesion removal patients. The surgeon must be confident that the prototype will allow them to cut tissue at a specific depth and length. The prototype cannot inhibit the surgeon in any way, such as being too cumbersome to use.

A surgeon's performance is based in part on the control they have over their instruments. As such, the prototypes must allow the surgeon to have complete manipulation of the surgical tool to perform precise incisions. The handle's grip must also be sufficient that the scalpel does not slip in the surgeon's hand during a procedure.

3.4 Design Constraints

The constraints of the project are manufacturing cost, time, budget, and the reluctance of most surgeons to adopt new technologies.

The manufacturing cost needs to be competitive with current products on the market. If the product costs more than current products and is not justifiably better, then administration will not pay for the product. The cost includes the price and amount of material used for the prototypes, if they were to be manufactured. The material needs to be able to undergo sterilization and wear from surgical use. Disposable, single use products can be created if they are a more economical option compared to multiple use products.

The time constraint placed on the project is to create alternative designs during B term and prototype the designs for testing by UMass surgeons. The optimized design will be fabricated during C term and modified based on further feedback from the clients.

Purchased materials for prototyping alternative designs will need to remain within the teams' budget of \$468. UMass has agreed to purchase novel scalpels available to surgeons. The scalpels will be used to determine the clients' interest and criticism towards currently available products.

After discussing project guidelines with the UMass client, it was understood that a difficult aspect of the project would be to create a prototype that a surgeon would want to use over the current technology. The client made it clear that, although there is a need for a better product, it would be difficult to obtain a uniform decision among surgeons whether a product was better than what they currently use. Each surgeon has their own methods and preferences for performing the same procedure, and the prototypes will need to address this.

3.5 Project Approach

Four scalpels were ordered for the UMass clients to test. Each scalpel was different from those currently used by UMass surgeons and each had its own unique design features. The first product ordered was a plastic scalpel which consists of an "ergonomically styled finger-grip barrel." The handle is highly contoured and grooved which will be used to gauge the clients' preference on handle curvature. The second product ordered was the Canica Standard Scalpel. This scalpel handle is wide at the top and tapers in towards the blade. There are circular grooves for added grip at the bottom of the handle. The Canica model is also described as ergonomic, and the feedback from surgeons will help the team to understand which designs are actually ergonomic and which are marketing catchphrases. The third product ordered was a scalpel, much like the ones used during surgeries performed at UMass, but consisted of a permanent sleeve attached to the handle. The sleeved scalpel was intended in part to determine the interest in pursuing a component that can be used to modify existing scalpels rather than designing a completely new handle. The last product ordered was the "Deluxe Stainless Steel Handle." This scalpel handle has larger dimensions (length, width, and height) compared to the currently used UMass scalpels. The Deluxe scalpel helped to understand the preferences of larger dimensions, and if they aid in the control of incisions.

Once the team receives the scalpels, the clients were videotaped creating incisions and commenting on the products. Based on their comments the team was able to understand the preferences of the clients including dimensions and weight. After the client meeting the group was able to use the preference information to create parameters for the scalpel handle weight, length, width, height, and curvature.

Alternative designs were generated based on the new parameters and analyzed. The analysis consisted of the force needed to control the scalpel and the force applied to the scalpel in order to create

an incision. Comfort, control, and precision were difficult to analyze prior to prototype creation because they were largely based on the clients’ preferences. Sketches were drawn for the prototypes and then rendered into CAD with exact dimensions.

Once the analysis was complete, prototypes were created for the alternative designs that met the parameters of the project. After the completion of the prototypes, UMass surgeons tested and commented on the designs, providing criticism that was used to further refine the scalpel handle parameters. The prototypes were improved based on the new parameters and more alternative designs were generated and analyzed. This process was continued until a prototype was developed that met with the clients’ approval. The final prototype was a design approved by the UMass surgeons.

The final prototype was analyzed so the preferences of the surgeons could be quantified. This allowed the group to optimize the design and create a final product to present to the clients. By quantifying preferences based on an analysis of the design, our project demonstrated the ideal dimensions for a surgical scalpel. In a broader sense, information learned from this project could be applied to optimize and refine other surgical instruments.

Chapter 4: The Design Process

4.1 Client Preferences

To better define the objects imposed on the project by the client, several of the scalpel designs currently on the market were tested. The scalpels shown in Table 1 as well as the standard scalpel handle used at UMASS Medical, which has been previously shown in this paper, were provided to a surgeon for trial and commentary. The scalpels were tested using a sample of human dermis and fat tissue excised from the lower abdomen, and the surgeon demonstrated the technique for the removal of small lesions. The demonstration was filmed from two different views to better understand the hand positions used when cutting with a scalpel.

Table 1: Description of current Scalpel Designs.

Vendor	Product	Website Link and Picture	Price	Weight (g)	Length (mm)	Perimeter (mm)
Bard Parker	Standard Scalpel		\$9.25	29.7	125	28
Canica	Canica		\$170.00	22.9	132	34.00

	Scalpel					
Martor USA	Ergocut - 20713	http://www.martorusa.com/Ergocut-20713 	\$10.45	11.2	129	42.10
VWR	SCALPEL HANDLE NO 5 BD, Catalog # 25856-023	http://www.vwrsp.com/catalog/product/index.cgi?catalog_number=25856-023&inE=1&highlight=25856-023 	\$19.60	30.7	120	60.60
WASCO- Wildlife Art Supply Company	Delux handle, Code # SH-5	http://www.taxidermy.com/cat/17/scalpel.html 	\$6.95	43	137	49.80

All of the scalpels suffered from similar problems, mainly being that they were too flat, and as such required awkward manipulation to achieve curved incisions. Other notable observations from the interview were the positioning of the surgeon's hand while cutting. The surgeon did not always grasp the scalpel at the grips, as one might expect, but instead grabbed closer to, and on top of, the scalpel blades. This was explained as compensation for poor handle design, as the scalpel attachment is more circular than the flat handles. Another interesting point in the demonstration was the actual cutting. Skin and the underlying layer of fat are significantly more durable than a layman would believe. Although the available blades were smaller than the surgeon would have preferred, he explained that it was generally very hard to cut, even with the correct blade. It was also explained that the lower abdomen region around the navel from which the cutting sample was taken is a very thick part of the skin. There is also a great deal of movement to the skin as it tends to flop around and stretch, making it even more difficult for the surgeon to cut. The surgeon explained that accuracy of the cut was partially determined by the position of the body and ensuring that the region being cut remains taught.

4.1.1 Standard Scalpel

The first scalpel analyzed was the standard scalpel, commonly used at UMASS Medical School. The need for a new scalpel design was identified through use of this model. Used all around the world for the past century, this scalpel handle has many drawbacks. Immediately upon cutting into the skin, it

became evident that the surgeon was forced to manipulate his body in awkward positions to compensate for the poor design. When making incisions, the upper arm and shoulder had to be turned, because the flat sides limit stable gripping positions. This problem, the surgeon noted, could be solved with a rounded handle. Several times during the procedure the surgeon compensated by holding the scalpel in awkward ways, such as holding the two thin sides of the scalpel.

Another complaint of the standard scalpel, not heard from us before, was the lack of grip. Although there are several indents near the blade attachment, they are not sufficient to maintain a secure grip, even in a controlled surgical environment. During surgery the scalpel handle may get wet from blood or other liquids and ability to securely hold the handle would be further decreased. The standard scalpel tends to move unpredictably and awkwardly as a result of its design.

4.1.2 ErgoCut Scalpel

This design was not found to be better than any of the other designs provided. More like an Exacto-knife than a surgical scalpel, the surgeon's first complaint was the narrow handle. Although the handle was not flat, the small diameter of the handle is not beneficial. The surgeon also did not like the texture of the scalpel. The design utilizes a hexagonal cross-section that alternates in orientation along the length. This leaves a lot of somewhat sharp areas. This scalpel was also not very stable, because of the pattern of indents.

Another concept that was examined in this design was the idea of a trough for the web space between the thumb and the hand. Although this feature was not intended in the Ergo Cut design, the surgeon compared the indents to an effort at making such a trough, which he believed would increase the comfort of the handle. In addition, the blade attachment method left a place for the finger to rest, possibly protecting it from the blade, a concept which the surgeon liked. Unfortunately, because it was not designed for this purpose even though it appears to encourage it, this feature is unstable and could actually lead to more slipping than it stops.

Slipping also occurred due to the lack of texture towards the blade end of the handle. Even the standard scalpel has a small amount of texture to prevent slipping. Although the ErgoCut design had a round handle, it was deemed non-effective for medical use, which is understandable as it is used in arts and crafts.

4.1.3 VWR Scalpel

Like the other scalpels, the surgeon immediately disliked this scalpel. One of complaints about this design was the size. It was too short to fit to the web of his hand, making it awkward to hold. Another problem was the sudden end of the gripping surface of the handle near the blade. The surgeon generally grabbed the scalpel close to the blade, and this made it so this handle was almost completely untouched.

The surgeon explained that this could be solved by the addition of a tapering portion between the grip of the handle and the blade.

This scalpel handle did have a trough for the thumb web, but the tapered middle did not reach to the web of the hand to rest upon. While the surface of the handle was textured for grip, there was still not enough friction for a secure hold. The greater problem was that the surgeon did not hold the handle where the grip was, effectively nullifying its benefits. The main complaint though for this scalpel would be the size, which is only efficient for those with small hands.

4.1.4 WASCO Taxidermy Scalpel

This scalpel was made for taxidermists. Although one member of our group really liked it, the surgeon did not. Upon picking it up the surgeon complained about the weight distribution of the handle, which gets heavier as it goes back. This scalpel seems to combine the flaws of the previously described scalpels.

The scalpel handle was long enough, but generally too clunky. Although the previous two designs had somewhat circular designs, this design is really just a wider version of the standard scalpel. It is flat, almost rectangular with slightly curved edges. As such, it requires similar compensation as the standard scalpel. The largeness actually appears to make it slightly easier to control, but it has numerous other problems.

This scalpel handle does not have a textured surface on the bottom of the handle to provide grip. Furthermore, the scalpel handle suffers from the same problem as the VWR scalpel, being that the handle suddenly ends, rather than tapering down to the blade insertion point. This scalpel was not as bad in this aspect, but the surgeon still grabbed the scalpel very close to the blade.

4.2 Morphological Chart

The two primary components of a scalpel are the blade for cutting tissue and the handle for holding and manipulating the blade. The blades are generally interchangeable so the same handle can be sterilized and reused. There are currently numerous patents for scalpels, many of which are novel handle designs and blade to handle interfaces. There are also a number of patents involving scalpel sleeves that encompass the handle. These sleeves are intended to provide the surgeon with a more comfortable shape and better gripping surface. This patent search and categorizing of scalpel handle designs were used to create a morphological chart.

Means feature/function	1	2	3	4	5	6
blade to handle interface	snap on	slide on	screw on	welded	glue/apoxy	X
grip texture	no texture	high friction material	symmetrical grooves	bumps	crosshatched grooves	indents
handle shape	straight	tapered	angled/curved	varying diameters	x	X
handle material	metal	polymer	mixture	wood	x	X
cross sectional shape	circular	elliptical	square	rectangular	I-beam	polygon
balance	imbedded material	multiple materials	length	weighted attachment	x	X

Table 2: Morphological Chart.

The morphological chart was created to help generate design alternatives. The main functions of the scalpel handle were identified and several means to fulfill these functions were proposed, as shown in Table 2. The morphological chart is used primarily as a guide to define the design space and visually represent all the design possibilities.

Using the morphological chart as the basis to form design alternatives, the team created preliminary sketches and chose six design alternatives to draft in CAD. These design alternatives will be discussed in more detail.

4.3 Pairwise Comparison Charts

Pairwise comparison charts were created to rank the project objectives by importance. This ranking was used to determine which objectives were most essential to the success of the design, within the allotted constraints. Each pairwise comparison chart was created through a discussion between group

members, comparing and contrasting the importance of each objective until a consensus was reached. The objectives were assigned either a one or a zero, to prioritize the importance. A value of 1 is assigned to the grid space on the chart if the objective in the associated row is more important than the one in the column. The pairwise comparison charts can be seen in Appendix A.

The first pairwise comparison chart that was created encompassed the primary project objectives. The control the surgeon had over the scalpel was determined to be the most important objective, followed by precision, comfort, easy to use, and inexpensive. Control held the most weight because this objective relates to how the surgeon will interface with the scalpel. The surgeon must have complete control in order to perform a surgery and have confidence in their incisions. Precision was chosen as the second most important objective. From the client meeting, it was learned that precision is generated from the surgeon's ability to stabilize their arms, shoulder, and body, limiting unbalanced movements. The precision the surgeon has will improve incision accuracy and limit tissue scarring. Although precision and control share similar attributes, they were chosen as separate objectives. The aspect of control in this project refers primarily to the ability the surgeon has to use the device while precision is the ability of the surgeon to hold the scalpel without having to move the rest of the body in an awkward position. Comfort was the third most important objective which involves how the scalpel feels in the hands of the surgeon. Easy to use, in that it scalpel sleeve is intuitive for the surgical nurses, was ranked as the fourth priority followed by inexpensive. The cost of the design fell to the bottom of the objective priority list because this goal does not interface directly with the surgeon, our primary client.

The first side chart that was made was the ease of use chart. In the general pairwise chart, easy to use was not considered the most important, gaining a weighted vote of only 0.1. Easy to use is made up of several subsections. It has to be easy to slip on the sleeve, remove the sleeve, clean the sleeve, sterilize the sleeve, and to identify the sleeve.

The ability to slip on or remove the sleeve easily will occur before and after surgery respectively. To easily clean the scalpel means that if blood or something gets on the scalpel it can be easily wiped off. Being able to easily sterilize a scalpel would be based on the material of the design and is important as all medical devices in surgery need to be sterile. The ability to easily identify the scalpel based on a color is more of a trivial design point that, although it would be nice, is not necessary. The ability to easily remove the sleeve was thought to be not as important because the time span to accomplish this is greater and many mechanisms for easy installation would also facilitate easy removal.

The subsection that was found to be most important was how easy it was to put onto the scalpel. It takes precedence over how easy it is to clean and sterilize because the sleeve could be made not sterilizable or able to clean, meaning it could be thrown out after each use, but fitting onto the scalpel is

the point of the sleeve. The abilities to easily remove the sleeve, clean the sleeve, and sterilize the sleeve were all found to be around the same level of importance. The ability to easily identify the blade was found to be the least important, although this should be very easy to design regardless.

Another side group that was made a chart of was the expense of the product. This was considered the least important in the general chart because, if the surgeons really like the sleeve, they will probably pay more for it. This is assuming that the price is only a small amount more than the current scalpel prices. It is doubtful that hospitals would pay significantly more for a design, even if surgeons really liked it.

The subsections of this chart were all of the categories that affected the price. Depending on the material, the design could be very expensive or very inexpensive. This needs to be weighed with the positives that the material brings to the design, like good mechanical properties. Ideally, a material must be found that is relatively inexpensive while at the same time having great mechanical properties. Another subsection was the quantity of material that was used. Depending on how big the scalpel design is, more material would be used. Although this amount may seem like only a little for one scalpel, when a hospital is ordering thousands of scalpels this price will add up. The final cost would be manufacturability. Different methods of manufacturing are available and offer different properties and different prices.

The results show that the material choice is considered the most important factor in making the product inexpensive. Second was the manufacturability of the design. Finally, the quantity of the material was thought to be the least important of the subsections.

Another side group chart that was made was the comfort chart. Comfort was ranked in the middle of the general objective pairwise comparison chart. This is because although it is very important, there were other groups that were simply thought to be more important. Both precision and control could result in injury to the patient which is really the thing that surgeons avoid most in surgery. It is important to note that if the scalpel handle is uncomfortable, surgeons will not use it and the design will be a failure.

Comfort was divided into three subsections. Weight is important and the surgeons are currently used to their own scalpels. Therefore, any scalpel sleeve could not weigh too much or the surgeons might not relate it to the old scalpels. Balance is important in the amount of control that the surgeon has. The scalpel should be balanced in such a way as the surgeon does not have to use an unnecessary amount of force to hold it. Shape was the final subsection. The scalpel should be designed in such a shape that it fits into the hand, working with the natural contours and layout of the surgeons' hand.

Shape was deemed the most important in this section, due to its ability to decide the surgeons' level of comfort. If the scalpel is not shaped in a way the surgeon finds comfortable, for example if it had several needle like sections sticking into the hands, the surgeons would not use it. The next was balance which was thought to possibly affect the control or precision and so is very important. If the handle does

not balance in the surgeons' hand, it will not feel right to the surgeon and they will dislike it. Weight was found to be the most inconsequential of the subsections, as the surgeon could get used to any weight assuming they like the balance and shape.

In the pairwise comparison chart describing the precision of the scalpel sleeve design, it was determined that the grip, width, and length were the most important attributes. The grip refers to the tactile control the surgeon has, preventing slipping, and was ranked as the most crucial objective to increase the surgeon's precision. Width was ranked as a more important objective compared to length because the group decided that the width of the scalpel sleeve will allow a surgeon to hold the device more securely, preventing the need for the surgeon to move their body in an un-stabilized position.

As shown in the pairwise comparison chart for control, the objectives that must be met in order for a surgeon to have control over the scalpel were grip, length, width, balance, and shape. The grip was seen as the most important objective because if the scalpel slipped in the surgeon's hand then the control will be compromised. Shape was determined to be the next priority when designing the scalpel sleeve for proper control because adjusting the shape will allow the surgeon to manipulate the scalpel and hold the scalpel in a more secure manner. The balance was the third most important attribute because an improperly balanced scalpel will be cumbersome to hold and limit the surgeon's ability to create incisions, thereby hindering their control. The width and length were ranked as the fourth and fifth attributes, respectively. The width was seen as more important compared to the length of the sleeve because more of the surgeon's hand contacts the width, so the group decided that alterations to the width would more readily increase the control the surgeon had compared to the width.

4.4 Function/Means Tree

The objective of this project can be most simply stated as modifying the handle of the scalpel to increase the stability, control, and comfort of the surgeon. We first identified three methods of accomplishing this: creating a sleeve to go around a current scalpel design, designing a self-contained handle, or developing an attachment to affix to the current scalpel handle design without fully encompassing it as a sleeve would. These categories are shown in Figure 10. We then looked into the means to create each of these three methods. For space considerations, the sub-branches of the sleeve, full handle, and attachment sections are displayed separately.

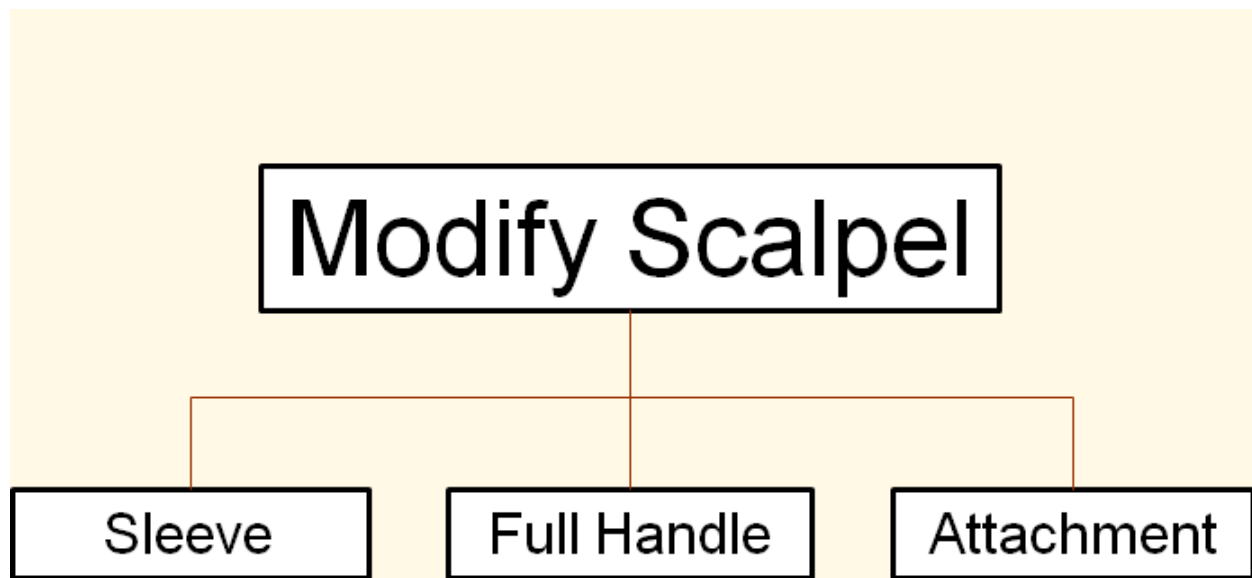

Figure 10: Function/Means tree main branches.

For the sleeve, we determined that there were three categories to further explore: shape, attachment method, and production method. These and their sub-branches can be seen in Figure 11. Within shape, we identified natural shape, cylindrical, hexagonal, octagonal, and elliptical as possibilities. The natural shape is one that conforms to the shape of the palm such as the one created by Wu and Luo in their study of pen grips [13]. Hexagonal, octagonal, and elliptical refer to possible transverse cross-sections of a scalpel handle with either straight or contoured designs.

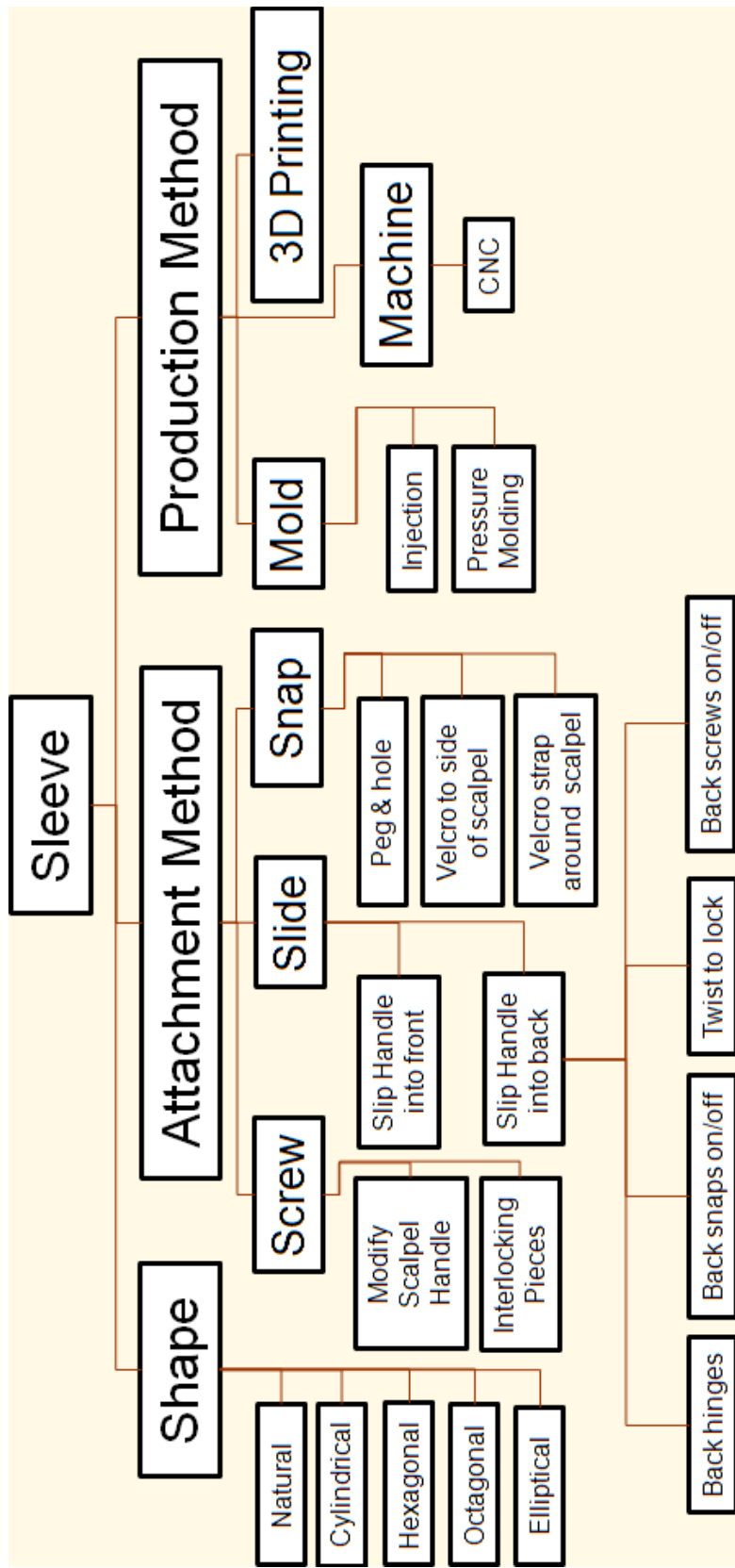

Figure 11: The branch of the Function/Means tree for the Sleeve option.

We determined that a sleeve could be attached to the scalpel handle by screwing on, sliding onto the existing handle, or snapping into place. For screw designs, the scalpel handle could be modified to have two halves of the sleeve screw through the scalpel handle, similar to many knife handles, or the sleeve could utilize interlocking pieces that screw together beyond the edge of the scalpel handle. For a design that slides on, the scalpel handle can be loaded from either the front or the back. When loading from the front, the pressure applied to the scalpel blade when making a cut will help stabilize the handle within the sleeve. For a back-loading design, cutting would push the handle out of the sleeve without a cap of some variety. Keeping the scalpel handle secured in a back loading design can be accomplished by having the back of the sleeve hinge, snap on and off, screw on and off, or by having an end with a rectangular hole into which the handle is loaded which then rotates 90° to lock in place. Snap designs included a peg-and-hole concept that would hold two halves of a design together like LEGO® bricks, using Velcro® to attach two halves of the sleeve either to the modified side of the scalpel or to itself, and using a Velcro® strap around the entire design to hold two halves of a sleeve onto the handle.

While production methods are dependent upon material and design considerations, we still found it useful to identify several possibilities. Injection molding or pressure molding could work for some design and material combinations. A CNC machine could also be utilized in some cases. For some plastics, a rapid prototyping machine such as a 3D printer could create our design.

We next considered how an autonomous scalpel handle could be created. This portion of the Function/Means Tree can be seen in Figure 12. The same shapes identified for a scalpel sleeve could be used for a full handle design. Likewise, the production methods remain unchanged between a full scalpel handle and a sleeve design.

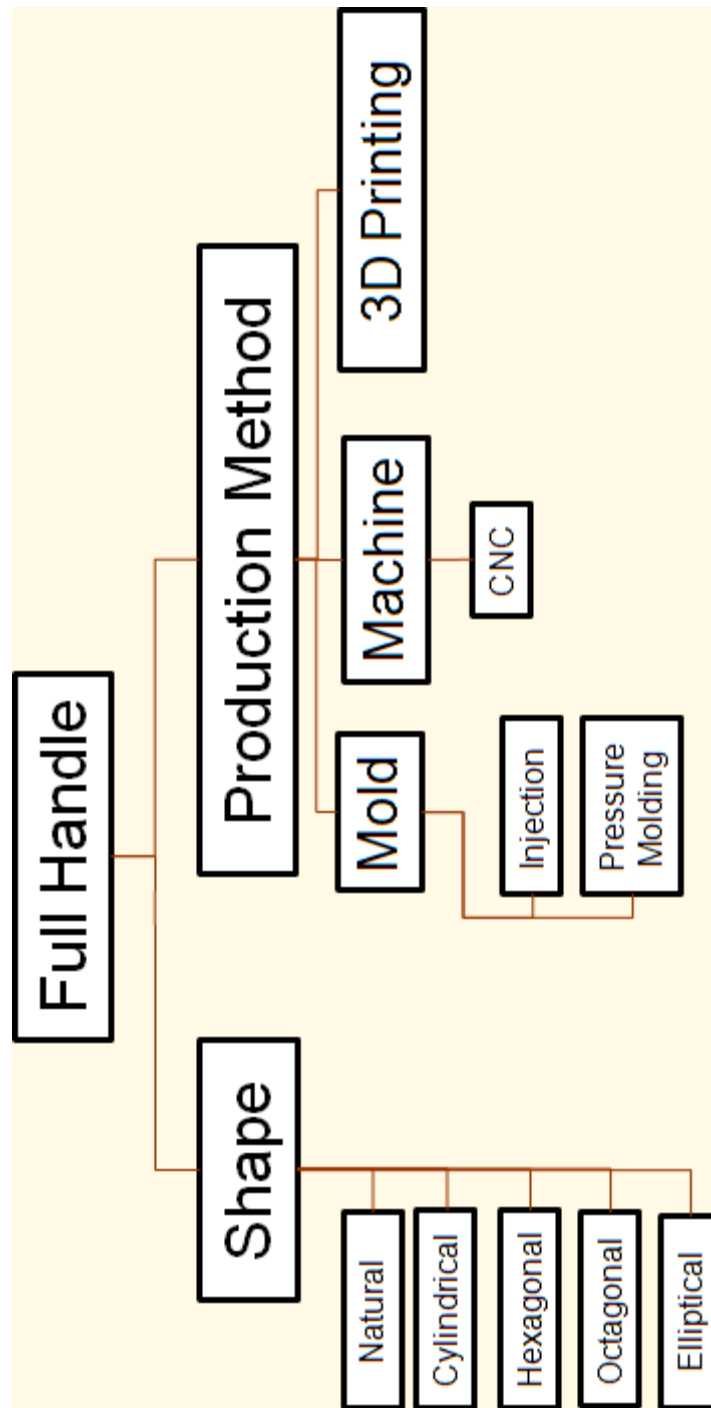

Figure 12: The branch of the Function/Means tree for the Full Handle option.

Finally, we considered the shape, attachment method, and production method for an attachment that would modify the shape of the scalpel handle without being a full sleeve. The results of this process can be seen in Figure 13. As can be seen in this figure, the production methods are the same as for the sleeve and the full handle.

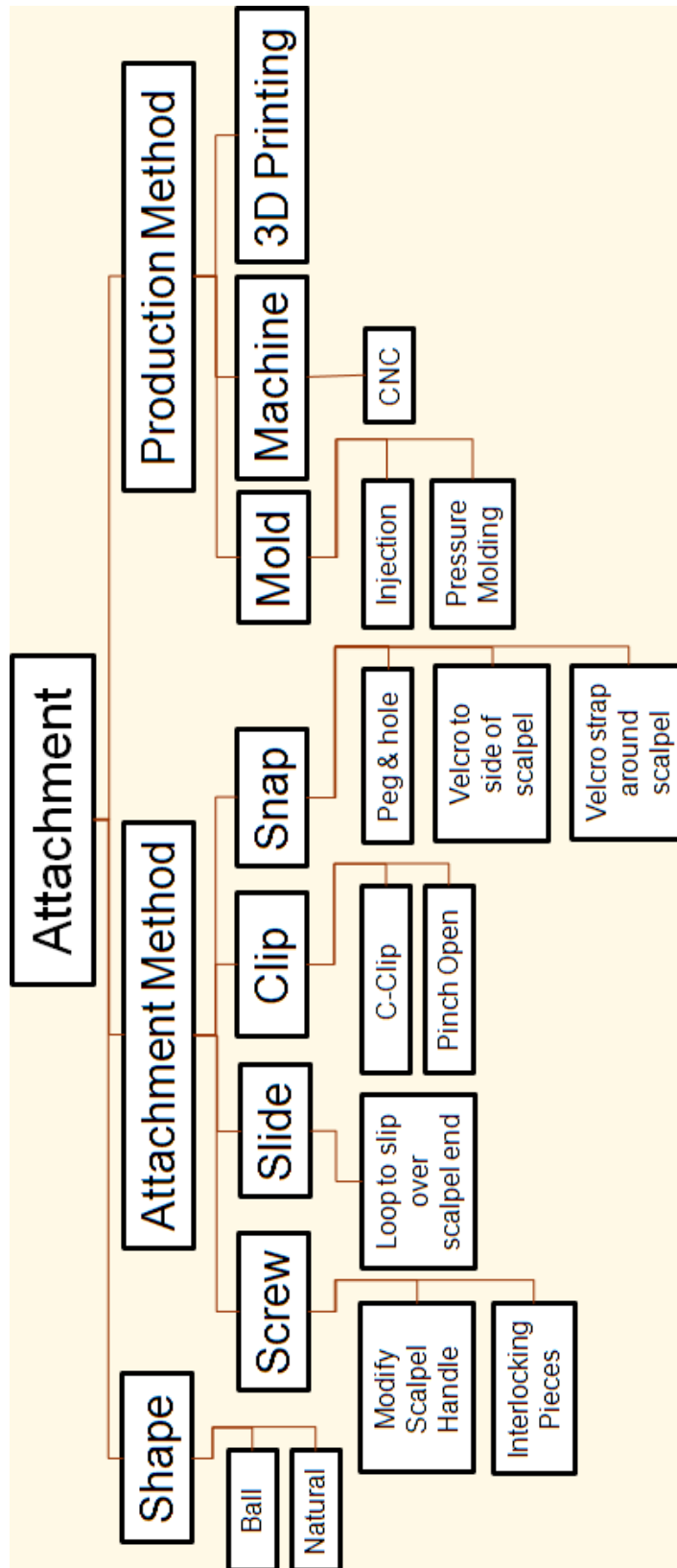

Figure 13: The branch of the Function/Means tree for the Attachment option.

Two possibilities were identified for the shape of an attachment. The first of these is a ball attached to the scalpel handle via a short stick. As was discussed in Chapter 1, this variety of attachment was developed by Wu and Luo [15]. The natural shape seen in the handle and sleeve designs could also be modified for an attachment.

There are a number of ways in which an attachment could be secured to the scalpel handle. For a modified handle, the attachment could be screwed directly into the side. It could be clipped to the handle using a modified C-clip like that used in the hands of LEGO® people, or using a spring-loaded clip that pinches open akin to an alligator clip. The attachment could include an adjustable loop to slide over the end of the scalpel. With appropriate modifications, the attachment could snap to the side of the handle in a manner akin to LEGO® blocks, or attach to the side with Velcro®. A velcro strap around the scalpel handle would also be an alternative.

4.5 Conceptual Designs

4.5.1 3-3-2 Process

In order to explore the many different designs possible our group decided to use a 3-3-2 diagram process. Theoretically in this process, each of us was to draw three alternative designs, then pass them around to the other group members. Each group member would put a list of comments, both complaints and advantages, onto each design.

Due to the M2D2 process, we had to expedite the design process and rush through the 3-3-2 process. For this reason, we did it twice. Before M2D2 we did it to quickly pick an optimum design and after we did it to further understand the design process and be presented with more design alternatives. The designs were created after the meeting with our client, and so took all of his complaints and considerations into mind. For the first 3-3-2, we analyzed seven designs, and for the second one we analyzed nine designs. These sixteen designs and their comments are in Appendix B. They all follow similar patterns.

One such pattern is the idea of a trough, talked about several times in the surgeons presentation. Many designs have such a trough, to rest the hand upon and enhance comfort. A couple designs also utilize a stopper, towards the blade to protect the fingers from the blade. This design feature was generally complained about, as it was not symmetrical and so might get annoying to the surgeon. Other non symmetrical scalpels, such as one that curves, to rest in the hand, was also ruled unacceptable due to having only one way to hold it.

Many different types of scalpel cross sections were thrown about in this process. The blade could be a polygon, round, oval, or even flat. Flat was generally agreed not to be good, as the original problem

with the current scalpels were there lack of curvature. Similarly, polygon shapes were capable of having sharp uncomfortable edges.

Many of the designs changed in diameter as the handle went out. Towards the fingers it could be round, then become thinner, then bulge out once more. Even more interesting the shape could change as the handle went out. It could be round at the fingertips, then oval shaped for maximum comfort at the web of the hand.

Using this process, a design was chosen for M2D2, and five others were later chosen for future modeling. The final chosen designs were somewhat combined with other designs, to combine all the advantages, and certain bad qualities were taken out. This process is more of a thinking exercise, creating many different alternative designs, which can then lead to innovation when combined.

4.5.2 M2D2

As part of the collaboration with UMass, the group was given the opportunity to present our current progress at the annual M2D2 event, hosted at UMass Medical School. The event showcased cutting edge biomedical products and ideas through PowerPoint presentations and a poster session. The group presented a preliminary prototype of a scalpel handle, Figure 14, to would-be investors. The presentation included defining the problem, our scalpel handle design and the justifications for it, the business potential and market for scalpel handles, and a comparison between commercial alternatives. The handout of the PowerPoint can be found in Appendix D.

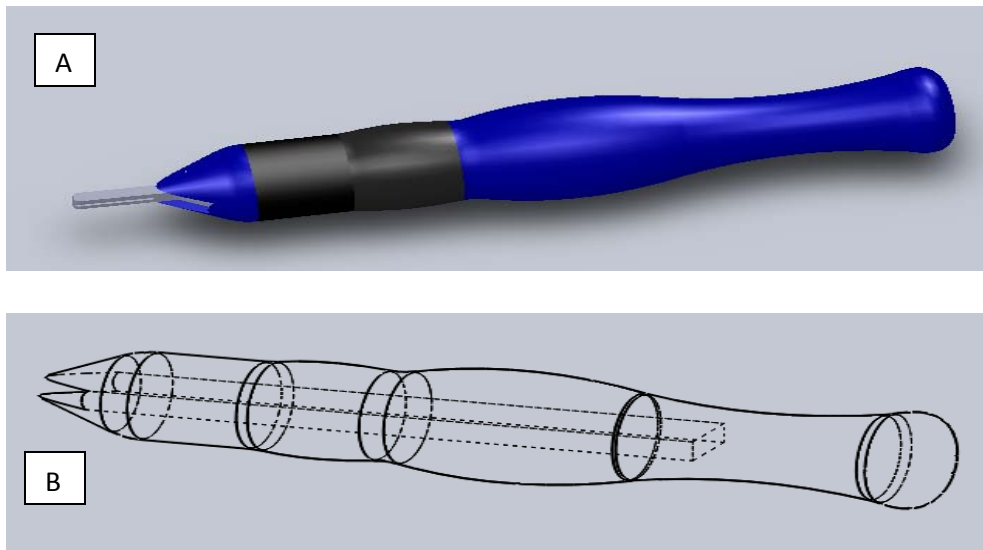

Figure 14: M2D2 Scalpel Handle Prototype. (A) shows a solid color picture, with the black part being the grip. (B) is a picture showing the slot inside, where the standard scalpel could slide into.

The poster session allowed time for the audience to ask questions and learn more about our project. The poster helped to clearly define the goal and significance of the project because it allowed more detail than the PowerPoint presentation. During the poster session multiple people showed an interest in our project, and were impressed that we were the only undergraduate group presenting at M2D2. A copy of the poster can be found in Appendix C.

M2D2 forced the group to generate design alternatives and choose one to render in CAD three weeks ahead of schedule. This pushed the pace of the MQP tremendously, but put us in a good position to begin prototyping and accomplish the B term objectives.

4.6 Alternative Designs

The primary means for design creation and refinement in the early stages of this project was through client feedback on designs. The notes from each meetings can be found in Appendix J.

4.6.1 Client feedback on Commercial Alternatives

Initially a variety of designs currently available on the market were purchased. These were presented to our sponsor on November 5, 2009 for analysis. The scalpels examined were the standard scalpel, the Ergocut scalpel, the large handle, and the VWR scalpel handle featuring molded plastic over the standard scalpel design. Due to ordering delays, the Canica Standard Scalpel was not included in this grouping.

Of the products tried, only the Ergocut design allowed for smooth handle rotation during an incision. The standard and large handles both had rectangular cross-sections, eliminating rotation, and the VWR handle did not sufficiently round out the design. In addition, all of the designs were found to have inadequate texturing along the gripping surface, allowing the handle to slip in the surgeon's hand. The large handle made no accommodation to reduce slipping and was instead smooth metal. The blade attachment method of the Ergocut scalpel produced a natural thumb-rest at the handle's gripping region which would have been appreciated had it not been a moving part. Another common theme for these products was that they did not rest naturally in the webspace between the thumb and the palm, thus allowing the back end of the scalpel to move around during incisions and reducing consistency.

It was also discussed whether our client had any surgical tools or other implements which they did find to be particularly comfortable. It was determined that his favored pen, the G2-Pilot Pen, had desirable dimensions. This, along with the feedback on the various commercial scalpel handles, was used to create our initial designs.

4.6.2 Initial Prototypes

A number of initial prototypes were created in order to test how well various design concepts worked in application. All of the designs were modeled using the SolidWorks 2010 program for computer aided design (CAD). Images of each design can be seen in Appendix E. These models were then created using a 3D printer. This variety of rapid prototyping machine extrudes lines of plastic next to each other to create layers, with layers being stacked on top of previous ones to create thickness. The machine used for prototyping creates parts of the polymer ABS, with a resolution of 0.02 inches in the x- and y-directions, and 0.01 inches in the z-direction.

A number of factors were considered when choosing shapes for each design. Several designs include tapering along their length to better fit the negative space created by the hand when holding a scalpel in the pencil grip, which is the most common way to hold a scalpel during surgical procedures. Research supports the idea that utilizing a larger diameter cross-section in the palm region increases control by increasing the contact area between the hand and the device. Tactile feedback regarding the rotation of the handle within the grip was also a concern, because this has a direct effect on blade angle. As has been discussed previously, the angle of incision is important for clean wound closure, which in turn reduces scarring. The interface between the scalpel handle and the webspace between the thumb and the palm was also taken into account, as per the wishes expressed by our client during the analysis of existing designs. While not every prototype attempts to address each of these factors, the set as a whole seeks to provide several means of accommodating each for the purposes of analysis and comparison.

4.6.2.1 M2D2 Design

This design was initially created based on the results of our first 3-3-2 exercise for presentation at the M2D2 conference. It features a circular cross-section throughout, with contouring along the length intended to fit the hand. The gripping surface is a slightly convex region. The handle then flares out to a larger diameter, providing more contact with the palm before tapering in again to rest along the webspace between the thumb and the hand, with a final outward flare at the back end of the handle to maintain the balance of the device.

4.6.2.2 Alternative 1

Alternative 1 is based on the results of the first 3-3-2 exercise. The gripping surface has a circular cross-section to allow for free rotation, while the back widens to a shape approximating a half-circle with the flat portion on top. This shape is intended to fit the curvature of the webspace between the thumb and the palm.

4.6.2.3 Alternative 2

Alternative 2 shares the same roughly half-circular cross-section as Alternative 1 in its back portion. Unlike the other design, however, the portion nearer the blade has a flattened top like the back region. This shape provides more tactile feedback for the surgeon about the rotation of the scalpel handle than a circular cross-section would.

4.6.2.4 Alternative 3

This design combined features from several of the concept sketches created for the second 3-3-2 exercise. The cross-section is nonagonal, with contouring to better fit the hand. It was believed that a nonagonal cross-section would provide distinct tactile feedback regarding the rotation of the handle while having angles obtuse enough to allow easy rotation and not be uncomfortable in the hand. The handle flares slightly outward just before the blade attachment point to prevent the surgeon's hand from sliding into the blade area. As a result of this outward flare, this design was the only one with the blade attachment portion perpendicular to a flat surface instead of utilizing a domed shape to transition from the gripping surface to the blade attachment portion. As the handle goes back from the gripping surface, it is contoured outward to fit the palm, in a manner similar to the M2D2 Design. The shape then tapers in again to fit the thumb webspace, with a nearly straight but still inwardly tapering portion at the back end.

4.6.2.5 Alternative 4

An elliptical cross-section was chosen for Alternative 4 because it gave greater tactile feedback concerning the rotational angle of the handle without adding any flattened edges that could inhibit free rotation. The handle widened slightly along the palm, but did so less than the M2D2 Design and Alternative 3. The end distal to the blade had a downward bend intended to curl around the back of the hand slightly for more stability.

4.6.2.6 Alternative 5

This design utilized a thin cylindrical for the body, with the only contouring being in the transition area between the gripping surface and the blade attachment point. It was thought that a straight design might be desirable over a contoured one as it would be more similar to the current standard flat scalpel. The end distal to the blade was bent downward as in Alternative 4, but the distance between the blade attachment point and the bend was greater. Material was also removed from the top of the handle in the region along the outside of the curve. This was partially to change the balance of the device and partially to reduce potential production costs by utilizing less material.

4.6.3 Client Feedback on Initial Designs

On February 18, 2010 the six initial prototypes were presented to our project sponsor for feedback. Alternative 3 and the M2D2 Design were the most preferred of the six. The designs were found to be somewhat slippery due to the ABS from which they were made.

It was determined that the natural gripping location for the M2D2 Design was too far from the blade attachment point, but that the shape of the back end was the best in the set. The outward flare before the end of the handle created a trough for the thumb webspace that will position the handle in the user's hand. As in many of the designs, the transition area between the gripping surface and the blade attachment point was thought to be too abrupt. The half-circular cross section used for Alternatives 1 and 2 was not particularly effective. The flat top in Alternative 2 was considered to be a detriment rather than an asset. Alternative 3's outward flare at the tip created a trough for the fingers. This effect was greatly appreciated as it allowed for greater control. The shape of the outward flare along the palm was determined to be the better than that on the M2D2 Design. However, it was found that the straight portion at the back of the handle provided no benefit. Alternative 4 had the best tip, as its elliptical cross-section lead to a gentler slope between the gripping region and the blade attachment area. The minimal beveling along the length of this handle was found to be ineffective at providing any benefit. The bent portion at the back of Alternatives 4 and 5 was found to be neither a benefit nor a detriment. The tendency existed with these designs to align the hand with the bend rather than the tip, so Alternative 5 was too long while the shorter Alternative 4 was better in this regard.

Based on the designs presented, it was determined that a combination of the M2D2 Design and Alternative 3 with a diameter more similar to that of Alternative 4 was the most promising option. The possibility of modifying the finger trough such that the thumb could grip further back on the handle than the fingers was raised, but it was determined that this was likely to negatively affect handle rotation.

4.6.4 Redesign 1

After receiving client feedback for the M2D2 Design and Alternatives 1-5, Redesign 1 was made in a number of variants approximating the same shape but differing in exact dimensions. This design combined the front end of Alternative 3 near the blade with the tail end of the M2D2 Design. As such, the handle flared out just before the blade attachment region, in the region along the palm of the hand, and at the end distal to the blade. This formed two troughs: one for the fingers in the gripping surface and one for the webspace of the thumb. A shallow dome was added between the outward flare at the tip of the gripping surface and the blade attachment region to make this area more aesthetically pleasing without

significantly increasing the distance between the blade and the gripping surface. The diameter of the gripping surface was also made smaller than in Alternative 3.

Each variant was based on the dimensions of Redesign 1.1. The client feedback from the first group of alternatives indicated that a diameter between that of Alternative 3 and the diameter of Alternative 4 would be ideal, but it was uncertain where within that range. As such, the diameter for Redesign 1.2 was made smaller than in Redesign 1.1 by 2 mm throughout the handle. Likewise, the ideal distance between the trough for the gripping fingers and the trough for the thumb webspace was unknown. Redesign 1.3 therefore reduced the area between the two troughs by 5 mm. Redesign 1.4 reduced the length of the trough for the thumb webspace by 5 mm to make the curvature of this trough more defined.

4.6.5 Client Feedback on Redesign 1

The variants of Redesign 1 were presented to our sponsor for evaluation on March 3, 2010. It was determined that the thickness of Redesign 1.1 was preferable over the reduced diameter of Redesign 1.2. The distance between the troughs was determined to be too short in all of the models. Redesign 1.4 was thought to be the most desirable of the variants due to the shortened trough for the thumb webspace, but the distance between troughs should be lengthened by approximately 1 cm.

The machine used to create the prototypes can only make pieces in the material ABS, which has poor mechanical properties. As such, extra material was added to the blade attachment region to add strength so that cutting tests could be performed. Our client felt that this half-cone shape on the back of the blade attachment portion should be integrated into the handle contour. This would allow the user's fingers to grip closer to the blade tip, which our client found was the natural tendency. It would also allow for the fingers to be offset from the thumb in terms of location down the length of the handle. The horizontal symmetry of the finger trough in Redesign 1 inhibits this, although it is a more natural gripping position.

The circular cross-section was found to be more slippery than the nonagonal. However, if this factor were eliminated through knurling and/or material selection, the circular cross-section would be preferable. It was also thought that the handle should be heavier, which will be taken into account during material selection.

4.6.6 Redesign 2

This design was a modification of Redesign 1.4. The distance between the troughs was increased by 1 cm. Knurling was added to the gripping surface in the form of parallel grooves around the handle.

circumference. The material initially intended to strengthen the blade attachment region was modified to also act as an extension of the gripping surface.

4.7 Feasibility

It was determined that our project was able to be accomplished within the monetary and time constraints set upon it. The budget for this project is \$156 per student for a total of \$458 with the opportunity to petition for more from the Biomedical Engineering Department should the need arise. In addition, our sponsor purchased all of the commercial alternatives that we selected using funding through UMass Medical School, eliminating the costs associated with our initial research and design development. The first prototype created was the initial variant of the M2D2 design, which cost \$9.00 to produce using the rapid prototyping machine on campus. This relatively low cost meant that we need not be particularly concerned about expenditures associated with prototype generation for developing and refining the shape of our design.

It was determined that time constraints were also reasonable for this project. A-Term was to be used for research, understanding the problem, and writing the Literature Review. B-Term was used for design development tasks such as defining the client's needs and objectives, developing design alternatives, and creating an initial prototype. C-Term was allocated to design testing and refinement. It was determined that the project could hypothetically be completed within this time period, but D-Term was also available for completion of the project if needed.

Chapter 5: Design Testing

5.1 Scalpel Analysis Utilizing a Force Plate

5.1.1 Testing Protocol

Using a black marker, 8 centimeter lines were drawn on a "self-healing" cutting surface. The lines represented three common incisions: linear, elliptical, and circular, as can be seen in Figure 15. The collaborating surgeon at UMass noted that the size of the incision markers were accurate representations of what is used during certain common operations. For force testing, the cutting surfaces were placed on an AccuSway force plate, which was in turn placed on a tall table. The testing subject stood next to the table and traced the lines with a scalpel, as shown in Figure 16. During the trials, the subject stood such that his chest was 15 inches from the center of the incision being created, and the subject leaned against the force plate as if during an actual procedure. Five trials of each incision were performed during initial testing. After reviewing the data, the observed variance between trials was not great enough to continue to

test five trials and three trial testing was used for all subsequent experiments. Data was collected and analyzed using BioAnalysis software along with Microsoft Excel.

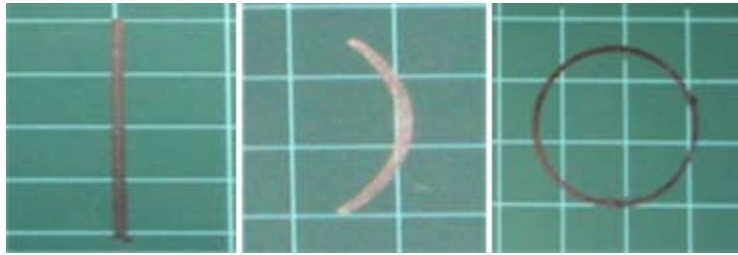

Figure 15: Linear, elliptical, and circular incisions were performed during testing.



Figure 16: The test subject standing during a trial.

During testing, two video cameras were setup to monitor the subject. A camera stationed at the top of the force platform facing the subject provided a top view which monitored the subject's hands and shoulder movement during the experiments and a camera stationed ten feet away from the subject provided a side view which monitored the subject's total body movement. A questionnaire was filled out by the subject after each scalpel was tested to assess qualitative aspects of the designs. The questionnaire can be seen in Appendix F and the testing data can be seen in Appendix G.

5.2 Results

5.2.1 Introduction of Variables

In order to better understand the results, it is important to understand what exactly was being measured by the force plate. The repeatable cutting surface was placed on the AcuSway force plate, as shown in Figure 17. The forces were measured in the X, Y, and Z directions. The X and Y axis are shown in the figure, while the Z axis is straight down into the force plate. This is also shown in Figure 18. For the purpose of this research, the Z force, the force used to create the incision, was ignored. This was due to the fact that the forces stayed relatively constant, independent of which scalpel was used. The forces in the X and Y axis were analyzed. Any change in force here would indicate instability, and therefore lack of precision and control. The moments were also analyzed, around the X, Y and Z axis.

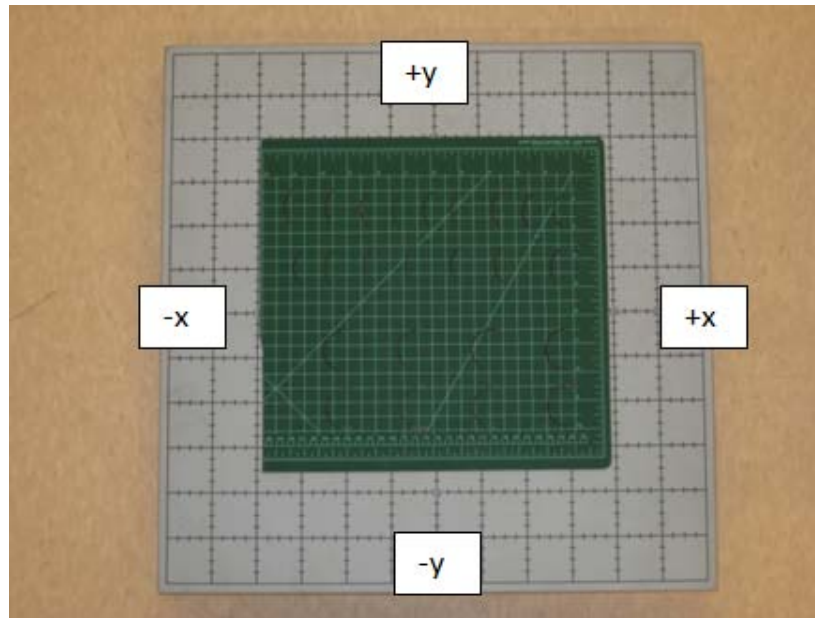

Figure 17: A self-healing cutting surface was placed on the AcuSway force plate for testing.

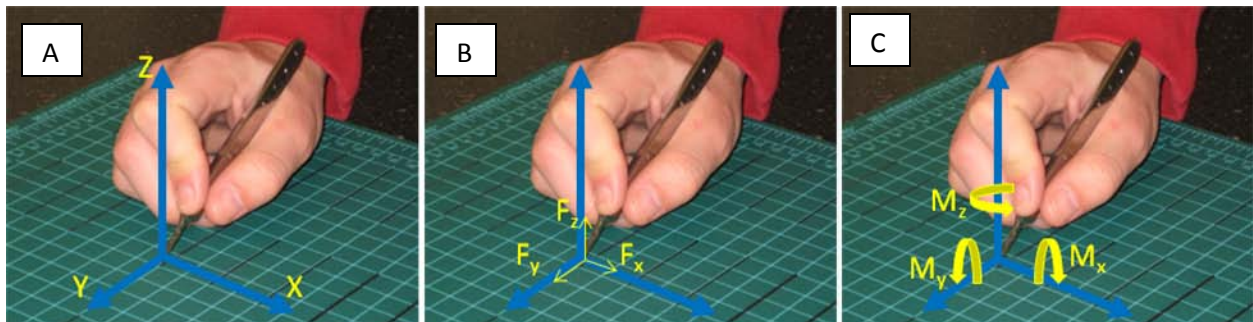

Figure 18: Demonstration of the axis, forces, and moments measured by the force plate. (A) shows the axis, (B) shows the forces and directions in according to the axis, and (C) shows the moments about the axis.

Elliptical incisions are used very frequently at UMass Medical Plastic Surgery for various procedures. During data analysis these trials were therefore considered most carefully. In particular, the counterclockwise direction was examined because it was more difficult to perform for a right-handed person, such as the tester and the client. While linear and circular incisions are also utilized in surgery, straight cuts offer fewer difficulties to fine control and the testing data for circular incisions was very similar to the trials for elliptical incisions. It was also felt that the true benefits of our design over the Standard Scalpel were best exhibited during curved incisions. The scalpel handles that are described below are the standard scalpel, the large handled scalpel, Alternative one, three, four, and five, as well as a variation on the final design. These pictures can be seen below in that order.

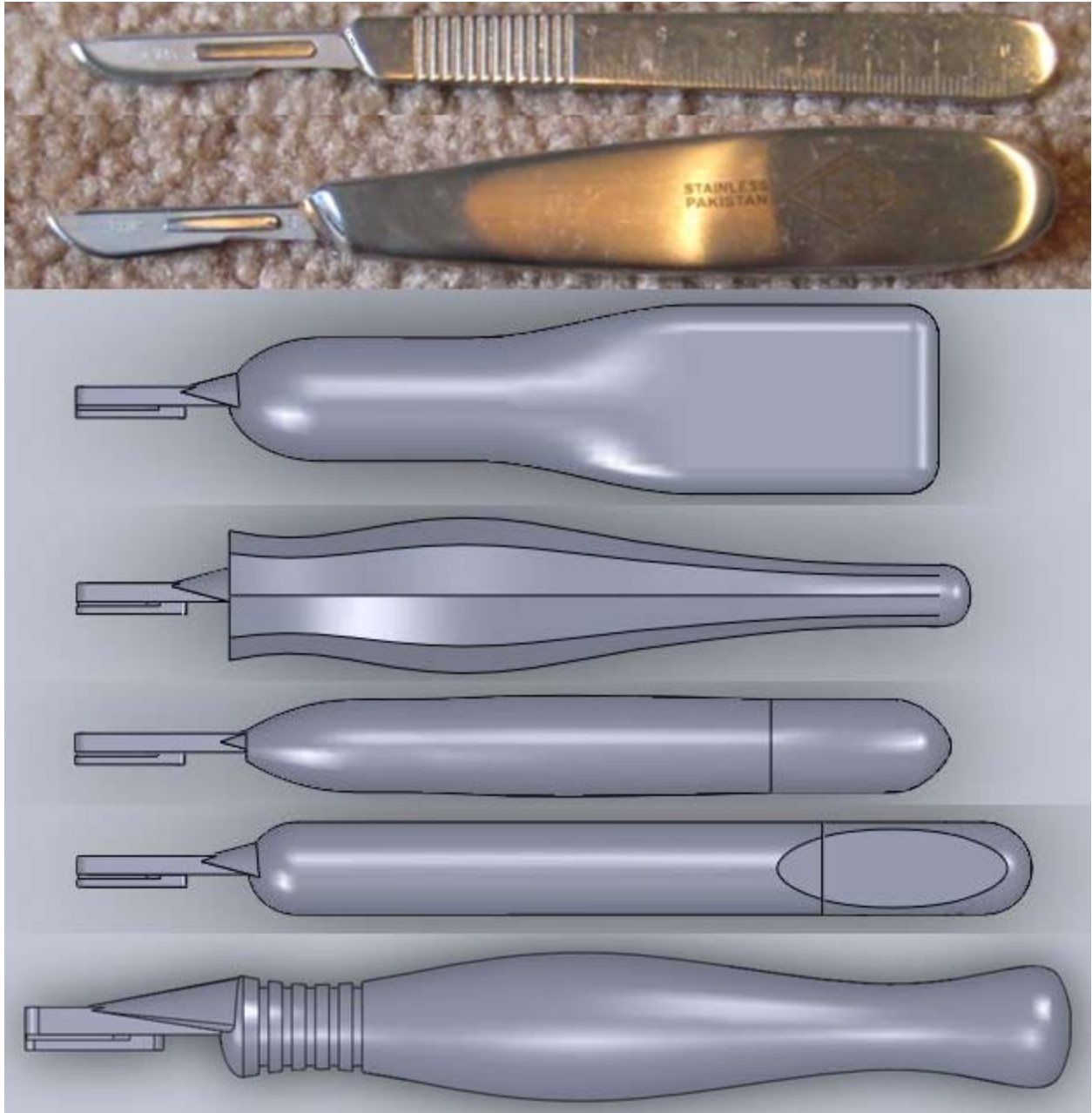

Figure 19: (Top to Bottom, images are not to scale) Standard Scalpel, Large Handle, Alternative 1, Alternative 3, Alternative 4, Alternative 5, Variation of Final Design.

5.3 Analysis

Analyzing the results of this experiment, consisting of 840 separate graphs, can be a somewhat daunting task. Several factors have to be accounted for when looking for signs of ergonomic discomfort. These factors will be described in greater detail, with evidence from the data, later in this section. The standard scalpels average data, for elliptical incisions, is shown below in Figures 20 and 21 as a reference,

for comparison with other, better scalpels. For the most part, linear incisions are relatively consistent throughout the scalpel process, the greatest differences being seen in the Elliptical and Circular, which are somewhat comparable. All the graphs can be seen in Appendix G.

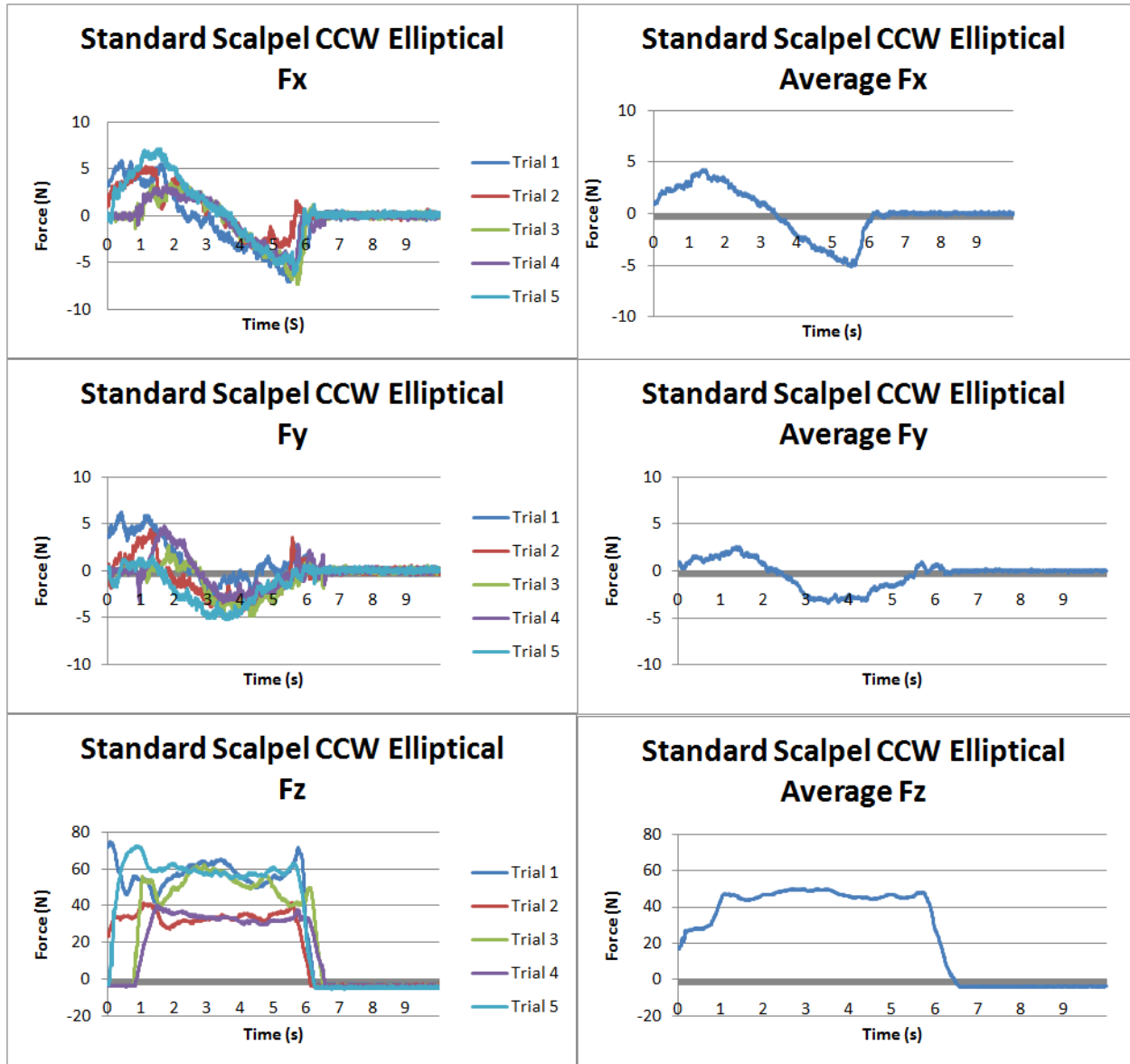

Figure 20: Forces collected during tests using the standard scalpel in a counterclockwise incision.

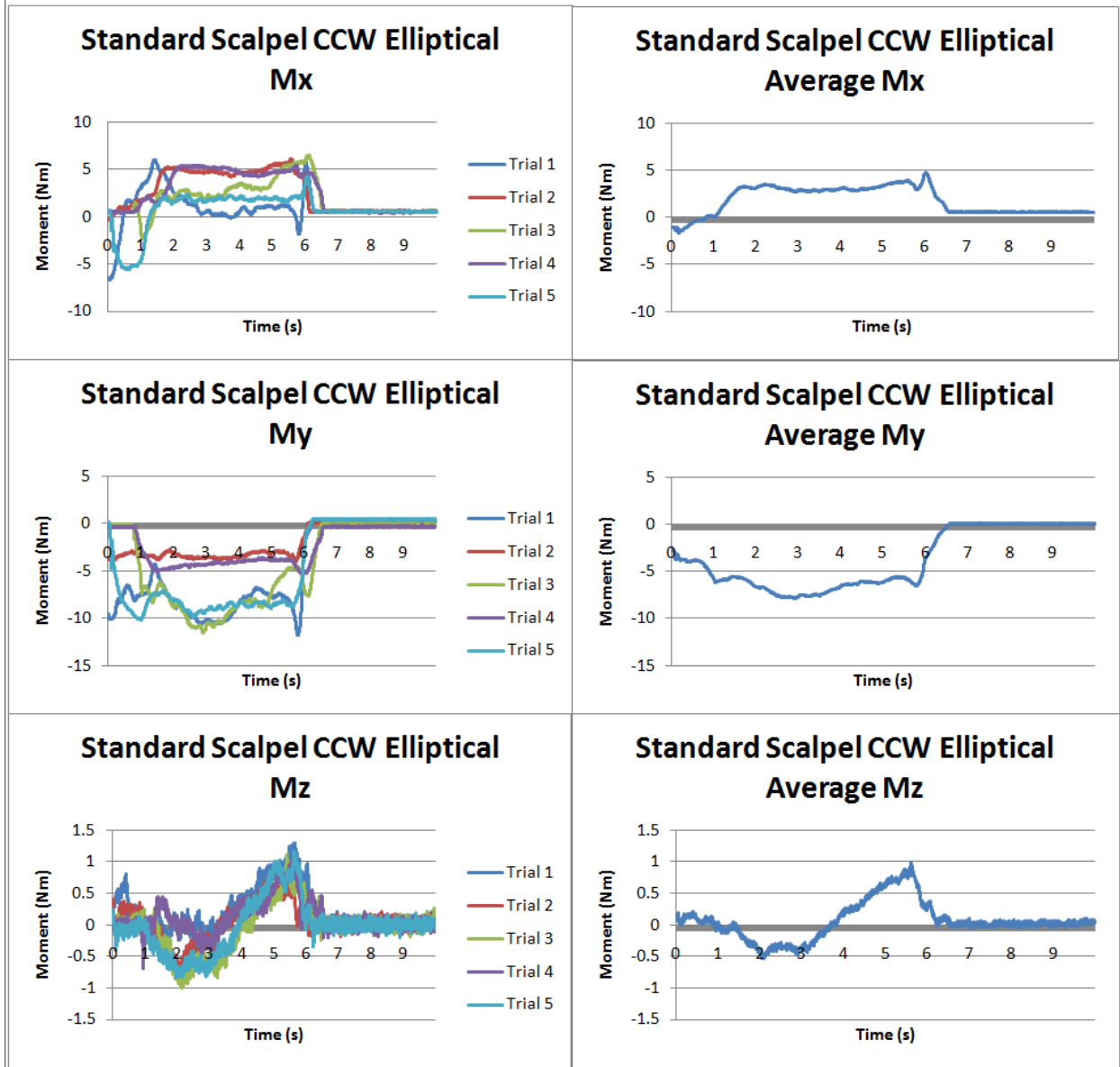

Figure 21: Moments calculated during tests using the standard scalpel in a counterclockwise incision.

The cutting in an ellipse is shown in each graph. The graph starts at or around zero, when the tester starts cutting. Then, for the force graphs in the X and Y direction it increases until the peak, as the scalpel travels around the ellipse. It passes zero on these two graphs as the scalpel reaches the center of the ellipse, effectively changing directions. The force in the Z direction is relatively constant, as the force pushing down onto the mat. The moments are the twisting of the scalpel around the respected axis.

Changes in the moment graphs, from positive to negative and vice versa, are signs that the hands are compensating for poor scalpel design. The hand, along with the rest of the body, would need readjustment, which is precisely what this new scalpel is meant to prevent. This can be seen clearly in the

standard scalpel data from above. In each of the moment graphs, the line crosses over the x-axis. In the M_z graph this happens 3 times. This is evidence of what the surgeon has already told us. The standard scalpel tends to flop in the hand, resulting in these fluctuating graphs. Below are the graphs for two different alternative designs developed, Alternative 1 and Alternative 4, each of which are an average of three trials. These graphs show a much smaller fluctuation. This could be because the handle is more circular, and therefore easier to turn, meaning less flopping.

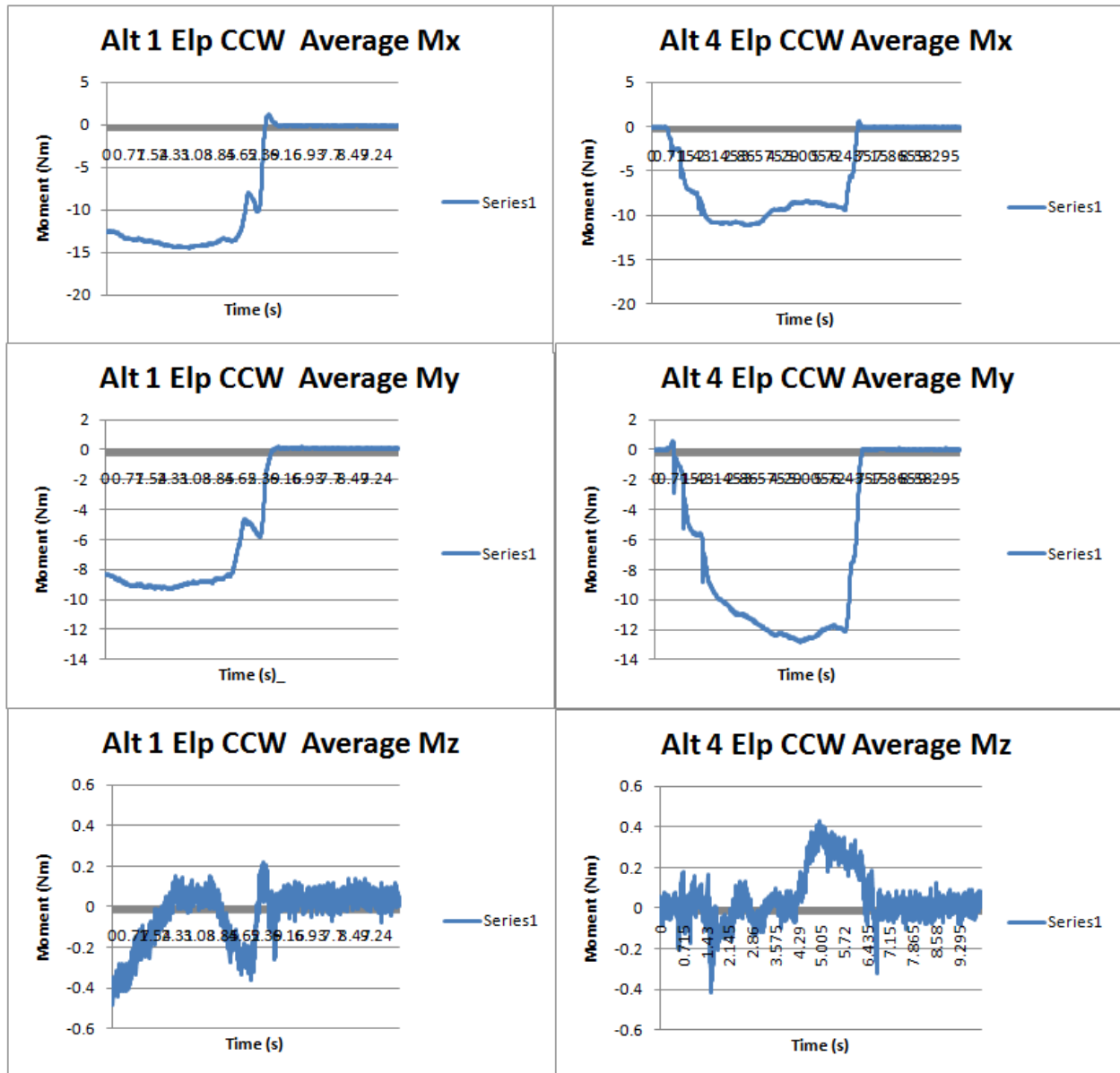

Figure 22: Moments calculated during tests using Alternative 1 and Alternative 4 in a counterclockwise incision.

Another sign of a bad scalpel would be a slight lag in the start of the test. This would indicate that the tester had trouble starting the incision, possibly trouble getting a firm grip on the scalpel. This lag can be seen in all the standard scalpel tests at the beginning and even greater in the large scalpel commercial alternative. This is consistent with the general opinion of the tester, who found the large scalpel difficult to handle, as seen in the survey filled out afterwards. There would be a certain amount of lag time associated with positioning the scalpel. Alternately, the 3rd alternative design has very little to know lag time. The graphs, placed next to each other, show a large lag time in the large handle, and none in the alternative 3 graphs. The Large Handle graphs are the average of five trials, while the alternative 3 graphs are of 3 trials.

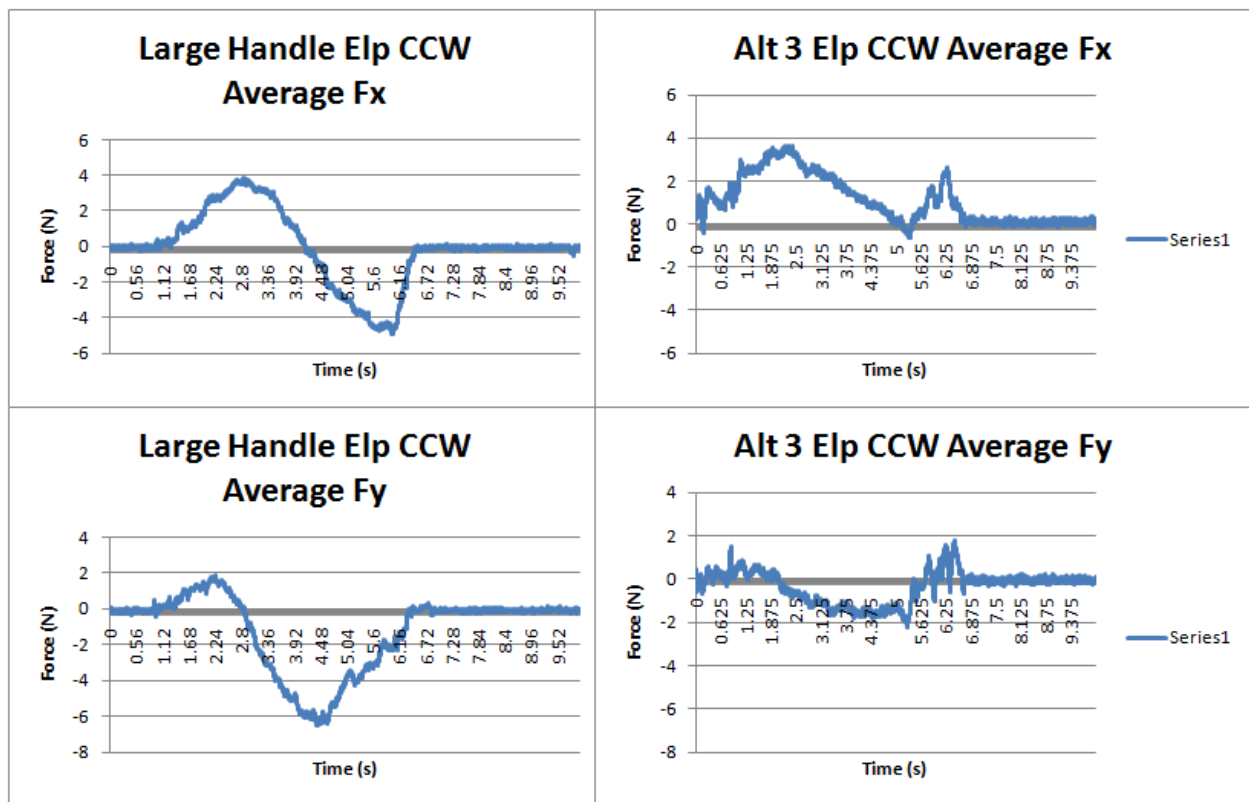

Figure 23: Moments calculated during tests using the large handle scalpel and Alternative 3 in a counterclockwise incision.

Finally, a change in the results over several trials would also show a weak handle. Each test had several cuts made into the sample, and over time, if the handle was not great, the results indicate that the tester changed their method of cutting, resulting in different forces and moment graphs. This change in cutting methodology indicates a scalpel handle design that needs compensation over time. This can be seen slightly in the standard scalpel. It can also be seen in the large scalpel graphs and all of the other

graphs. Since only three to five trials were done, this does not seem to be an issue, although if a large amount of trials were conducted, it might become more evident.

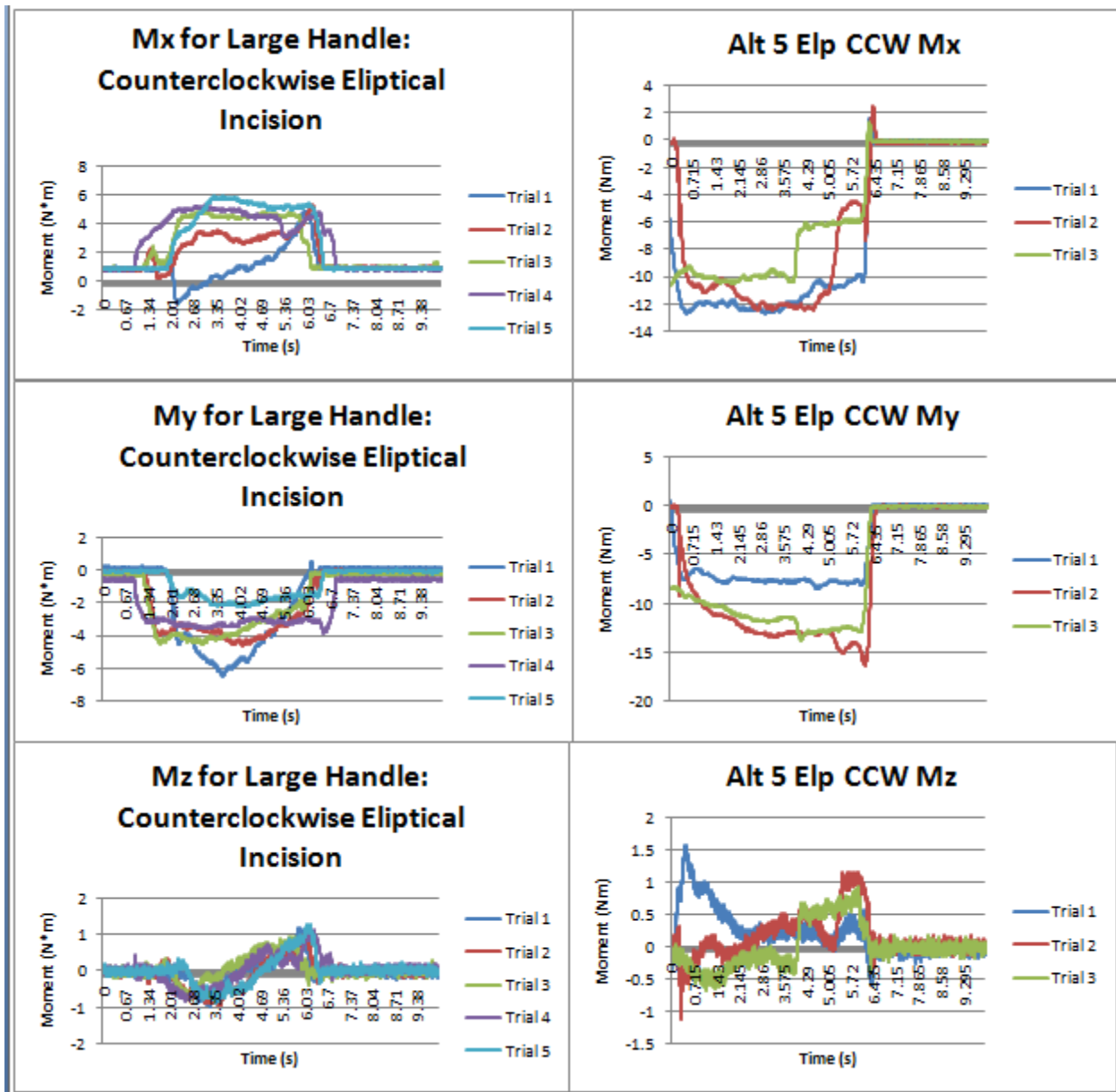

Figure 24: Moments calculated during tests using the largehandle scalpel and Alternative 5 in a counterclockwise incision.

Chapter 6: Final Design

6.1 Final Design Results

The final design was made using quantitative and qualitative data. The quantitative data came from the force plate, while the qualitative came from the talking with surgeons and asking how they felt about the design. Using all of this data we were able to create several final prototypes that we saw as much more ergonomic. These were then narrowed down to a final prototype, after again speaking with surgeons.

The graphs below show the data for a variation of the final design that was heavily favored by UMass surgeons over the other variations. When compared to the results of the standard scalpel, there is a significant difference in the graphs. The graphs are averages, of three trials for the variation and five for the standard scalpel, of the forces in the X and Y direction, as well as the moment about the Z axis.

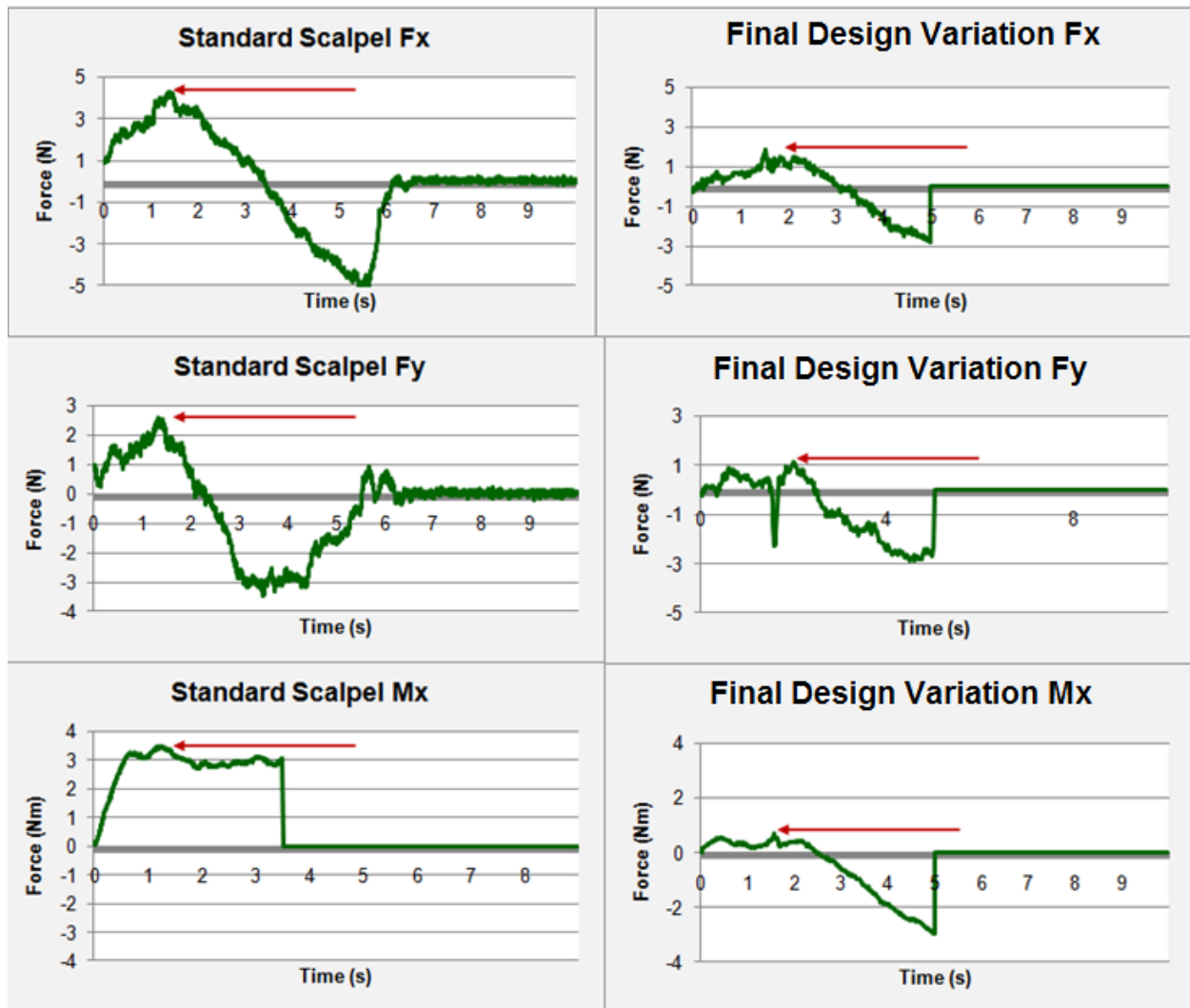

Figure 25: Comparison of Forces and Moments between the Standard Scalpel and a variation of the final design.

At the beginning of this experiment we hypothesized that large forces in any direction other than Z, were bad, and indicative of low precision, control and comfort. High moments are also negative results, showing too much twisting of the handle. The results shown above show a large difference in forces and moments. These can be seen more clearly in the graph below.

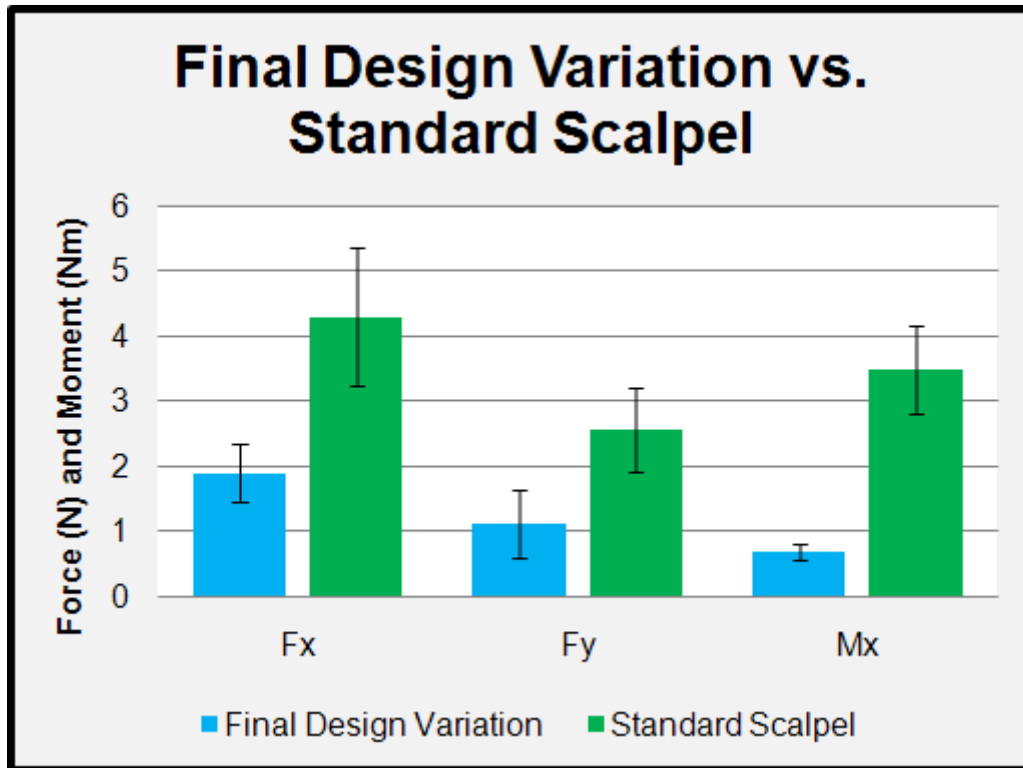

Figure 26: Peak force and moment values for the standard scalpel and a variation of the final design

6.2 Surgeon Survey

To optimize our final design, we administered a survey to eight surgeons and surgical residents at UMass Medical. The purpose of this survey was to define dimensions of our scalpel handle based on a small sample of its intended users. From the survey, we also intended to find areas where we would need to refine our design. We manufactured nine scalpel handles, with the same shape, altering the gripping perimeter and length. The surgeons were provided with the same repeatable cutting surfaces used during force testing to test the scalpel handles.

The survey asked the surgeons to rank the comfort, control, and precision for their preferred scalpel handle. The definitions of these words were presented on the survey to prevent misinterpretations between individuals with an engineering and medical background. The definitions were:

- *Comfort*: qualitative assessment of how the scalpel handle feels in the user's hand. Comfort derives from the hand positioning in relation to the design of the scalpel handle. Scalpel handle and blade length, diameter of grip, cross-sectional design, and balance are factors that affect the user's comfort.
- *Control*: A description of how well the scalpel handle interfaces with the user's hand. A design that tends to turn or flop in the user's hand during a particular incision will be a design that

provides less control than one where the scalpel handle remains stationary in the user's grasp. Control is gained by a design that does not slip or rotate unexpectedly in the hand.

- *Precision:* Precision is generated from the surgeon's ability to stabilize their arms, shoulders, and torso, limiting unbalanced movements. Improving precision requires the scalpel handle to be designed such that it will not force the surgeon to move their body in an undesirable manner.

The ranking was on a 1 to 5 scale, the value of 1 representing a characteristic or dimension that was either low or not preferred and the value of 5 representing a characteristic or dimension that was highly preferred. The parameters the surgeons were to rank that involved comfort were handle length, diameter of gripping area, cross-sectional design, and balance. Tendency for the scalpel handle to rotate in an undesired manner in the surgeon's hand was the control parameter. The final consideration the surgeons were questioned about was to rank whether the scalpel handle presented body stability issues, which defined precision.

The results of the survey showed that all of the surgeons' preferred the smallest gripping perimeter, with additional comments that they would like it to be further reduced in size. The preferred lengths of the scalpel handle varied from surgeon to surgeon.

A copy of the survey can be found in Appendix H.

6.2.1 Comparison to Golden Section Data

The results from the surgeon survey can also be shown to prove a connection between the golden section ratio, and a more ergonomic design. As argued above, larger forces show a less ergonomic design. The ratio between the perimeter of the scalpel handles at the grip and the length of the sharpened portion of a #10 scalpel blade, one of the sizes used most commonly in plastic surgery. These dimensions are shown in Figure 27. The table included in Appendix I shows this data for all commercial designs, as well as all of our prototypes. The standard scalpel shows a 56 percent difference from the golden ratio, while the final design is only 28% different. This shows a force reduction that correlates with becoming closer to the standard scalpel. Other redesigns showed similar correlations.

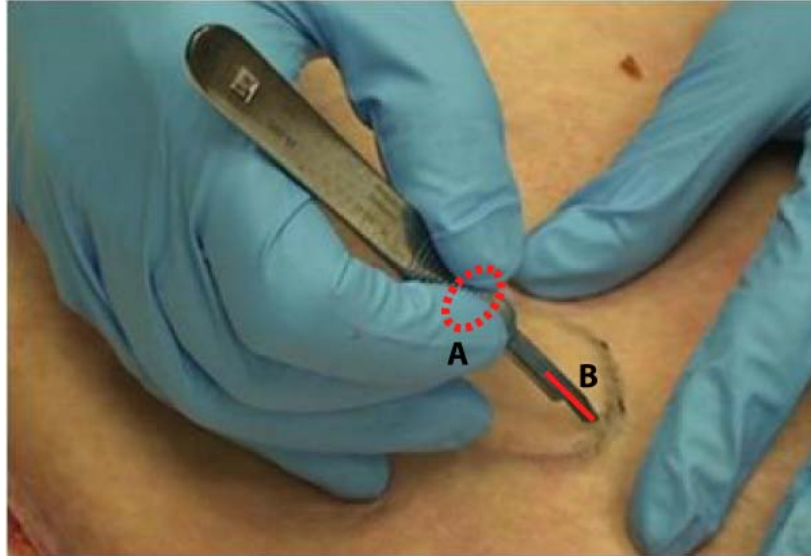

Figure 27: The ratio between the handle perimeter and the blade length was compared to the Golden Section Ratio.

Chapter 7: Future Developments

This MQP, Improving the Ergonomic Design of Scalpel Handles, has provided the foundation for future engineering design problems regarding the interplay between human interactions and ergonomics. As our results demonstrate, there is a clear relationship between the Golden Section Ratio and the forces exhibited on a scalpel handle. Future studies can cite our project as a means to base consequent research into improving the ergonomics of other surgical instruments. As well as insight into the field of ergonomics, future development can be taken into manufacturing the ergonomic scalpel handle for commercial use.

7.1 Ergonomic Factors

Future considerations into creating different sized ergonomic scalpel handles should be researched. The proportions of our final design can be altered to accommodate varying hand sizes. A commercial solution to this idea would be to produce three different sized scalpel handles; sizes small, medium, and large. Having a scalpel handle sized specifically for a surgeon's hand would further increase the comfort, control, and precision this project sought to improve. To pursue this idea further, research into hand size to scalpel size preference would need to be conducted.

Another factor of ergonomics in surgical tools that could be extended beyond this project is to classify surgeons based on personalities and design instruments for each group. For

example, group A could have a preference of thick and broad tools while group B has a preference for thin and narrow tools. Although the forces exhibited onto the instruments might vary as the dimensions of the tools change, the surgeon's personality would not. Therefore, by designing based on personality, rather than for optimal force reduction, we could reach a broader market.

7.2 Manufacturing

As a group, if we were to continue this project, our next step would be to manufacture the ergonomic scalpel handle for commercial use. This MQP created an optimal design which increased the comfort, control, and stability a surgeon has compared to their current scalpel handle. Since the design does not need to change, we could manufacture handles from metal, for repeatable use, and from plastic, which would be disposable. Additionally, scalpel handle sleeves could be manufactured based on the dimensions of our design, where a standard scalpel is inserted into the sleeve.

Material choice, apart from whether the design is reusable or disposable, should be considered to add additional traction to the scalpel handle surface. Polymer blends should be researched and studied to create an ideal gripping surface for the scalpel handle. Surgical environments are typically wet and a scalpel slippage is not an uncommon occurrence. Having a polymer blend would improve the gripping surface compared to grooves machined into a metal surface, thereby reducing the risk of the instrument slipping.

After production considerations are underway, the scalpel handles could be color coded to have a scalpel blade associated with each color. This would provide a clear blade to handle identification system and limit confusion in an operating room.

References

- [1] Gielo-Perczak K. The Golden Section as a Harmonizing Feature of Human Dimensions and Workplace Design. *Theoretical Issues in Ergonomics*. 2001;2:336-51.
- [2] Marrero IC, de la Torre JI, Sahin B, Wilhelmi BJ. Hand Anatomy. *eMedicine from WebMD*; 2007.
- [3] Tattersall J. *Elementary Number Theory in Nine Chapters: The Press Syndicate of the University of Cambridge*; 1999.
- [4] Irvine CH, S.H. S, J.H. S. Stairway risers and treads: acceptable and preferred dimensions. *Applied Ergonomics*. 1990;21:21.
- [5] Hsiang SM, McGorry RW, I.B. Bezverkhny. The use of Taguchi's methods for the evaluation of industrial knife design. 1997;40:15.
- [6] Camer RH. Skin Lesion Removal. *Encyclopedia of Medicine*2006.
- [7] Decampli WMHC, Atherton, CA, 94027). Scalpel handle having retractable blade support and method of use. United States1996.
- [8] Parker B. BD surgical Products. 2009.
- [9] Carol J. DeFrances PD, Christine A. Lucas MPH, M.S.W, Verita C. Buie DPH, Golosinskiy A. 2006 National Hospital Discharge Survey. *National Health Statistics Report*. July 30,2008 ed: National Center for Health statistics; 2008. p. 9.
- [10] Edwards M. How to use a Scalpel. *Primeskills in surgery: wikisurgery*.
- [11] McGorry RW. A system for the measurement of grip forces and applied moments during hand tool use. *Applied Ergonomics*. 2001;32:271-9.
- [12] Goonetilleke RS, Hoffmann ER, Luximon A. Effects of pen design on drawing and writing performance. *Applied Ergonomics*. 2009;40:292-301.
- [13] Wu F-G, Luo S. Performance of the five-point grip pen in three screen-based tasks. *Applied Ergonomics*. 2006;37:629-39.
- [14] Wu F-G, Luo S. Performance study on touch-pens size in three screen tasks. *Applied Ergonomics*. 2006;37:149-58.
- [15] Wu F-G, Luo S. Design and evaluation approach for increasing stability and performance of touch pens in screen handwriting tasks. *Applied Ergonomics*. 2006;37:319-27.
- [16] VWR. *Blades, Knives and Scalpels*. 2007.
- [17] Scientific F. *Knives and Knife Blade/Scalpels*. 2009.
- [18] Canica. *Canica Standard Scalpel*. 2009.

- [19] Holman RGS, ZA). Disposable scalpel with retractable blade. United States: Trevor John Milton (Johannesburg, ZA); 2008.
- [20] Dillon J, Singh, Mobbs, William, Leonard. SCALPEL. NOBLE HOUSE GROUP PTY,LTD,Dillon, Jagmohanbir Singh Mobbs William Leonard; 1995.
- [21] Masury DHFL, Kittery Point, ME, US), Thompson, Edward P. (57 Salter St., Portsmouth, NH, US). Surgical scalpel. United States2007.
- [22] Sandel DSC, CA, US), Jeter, Ruane (Chatsworth, CA, US). Scalpel. United States: Sandel Medical Industries, LLC (Chatsworth, CA, US); 2008.
- [23] Huschmand Nia AN, Göttingen, 37075, DE). SCALPEL. Georg-august-universität, Göttingen (Wilhelmsplatz 1, Göttingen, 37073, DE),Huschmand Nia, Abdolhamid (Nonnenstieg 3, Göttingen, 37075, DE); 2004.
- [24] Griffin MDBS, Northridge, CA, US), Gaba, Rodolfo (722 Harper St., Simi Valley, CA, US). Safety scalpel. United States2007.
- [25] Dee RNTA, Eastchester, NY, 10709), Reich, Charles (57 W. 57th St., New York, NY, 10019). Scalpel with universally adjustable blade. United States1987.
- [26] Lundgren DAK, Hovas, S-430 80, SE). SCALPEL. Lundgren, Dan (Askims Kyrkväg 5, Hovas, S-430 80, SE); 1995.
- [27] Wu JF, No. 18, Lane 34, Minzu Rd., Banciao City, Taipei County 220, TW). Scalpel handle for left handed. United States2009.
- [28] Wu JF, No. 18, Lane 34, Minzu Rd., Banciao City, Taipei County 220, TW). Scalpel handle for right handed. United States2009.
- [29] Montelius GA. Scalpel. United States: Montelius, George A.; 1953.
- [30] Wilson MPS, FL, US). Anatomical handle for surgical precision scalpel. United States: Medideas, Inc. (Sarasota, FL, US); 2007.
- [31] Dunn RS, MA, US). Adapter Sleeve. United States: UNIVERSITY OF MASSACHUSETTS (1 Beacon Street, Boston, MA, US); 2008.
- [32] Webb NJBD, Box 831, Wrightwood, CA, 92397). Ergonomic surgical scalpel sleeve. United States1996.
- [33] Noack WLS, CA). Scalpel handle and blade release assembly. United States: Devon Industries, Inc. (Chatsworth, CA); 1994.

Glossary

Accuracy – The ability the user has to follow a traced line with the scalpel.

Balance- The weight distribution of the scalpel handle and how it affects the way it feels in the user's hand. The balance can be described by location (front, top, side) and relative weight (light, heavy).

Comfort – A qualitative assessment of how the scalpel handle feels in the user's hand. The comfort derives from the hand positioning in relation to the design of the scalpel handle. Different shapes will provide different hand positions, some of which can be awkward and deemed uncomfortable. This could change depending on the user.

Control – A description of how well the scalpel handle interfaces with the user's hand. A design that tends to turn or flop in the user's hand during a particular incision will be a design that provides less control than one where the scalpel handle remains stationary in the user's grasp.

Ergonomic - characteristic of an object or tool designed to optimize utility and user productivity by reducing operator fatigue or discomfort while facilitating safety, operator health, and efficiency.

Force to create incision – The effort exerted by the user when attempting to create an incision.

Grip – Although there are several common ways to hold a scalpel, such as a pencil or knife grip, the user generally uses a hand position that provides control and comfort. This does not refer to the traction the scalpel handle provides for the user.

Gripping Surface – This is the region where the user's fingers grip the scalpel handle. This region is often textured to provide more friction and reduce the chance that the handle will slip within the user's grip.

Hand position – The relative location of the user's hand on the scalpel and the location of the opposite hand which supports the user during an incision.

Incision shape- Depending on the location and purpose of a surgery, there are several different types of incision shapes. Common incision shapes are, elliptical, linear and circular.

Scalpel –Tool used by surgeons (the user) to create incisions, consisting of both a blade and a handle.

Scalpel Blade- Cutting portion of the scalpel. They are developed in different sizes and shapes depending on the type of incision. Scalpel blades are discarded after use.

Scalpel Handle- The portion the user grips the scalpel with. The handle material is generally made from a plastic, for use as a disposable unit, or metal, for use as a reusable unit. Typically, the scalpel handle will have grooves to provide traction.

Stability – Stability refers to the effect the scalpel handle has on the user's body position. If the scalpel handle is created in such a way that it requires the user to move their body (i.e. their shoulders, arms, elbows) in an unsupported manner, then the scalpel handle will prove to be a design that decreases stability.

Traction- The tactile feel and friction the scalpel handle provides the user with. This is particularly important during surgery when conditions are wet and slippery.

Appendix A: Pairwise Comparison Charts

General Pairwise Comparison Chart							
	easy to use	Inexpensive	comfort	precision	control	results	Weight
easy to use	x	1	0	0	0	1	0.1
inexpensive	0	X	0	0	0	0	0
comfort	1	1	x	0	0	2	0.2
precision	1	1	1	x	0	3	0.3
control	1	1	1	1	x	4	0.4

Easy to use Pairwise Comparison Chart							
	slip on	remove	clean	sterilize	identify	results	Weight
slip on	x	1	1	1	1	4	0.4
remove	0	x	0	1	1	2	0.2
clean	0	1	x	0	1	2	0.2
sterilize	0	0	1	x	1	2	0.2
identify (blade)	0	0	0	0	x	0	0

Inexpensive Pairwise Comparison Chart					
	choice	quantity	manufacturability	results	weight
material choice	x	1	1	2	0.66
material quantity	0	x	0	0	0
manufacturability	0	1	x	1	0.33

Comfort Pairwise Comparison Chart					
	Weight	balance	shape	results	weight
weight	X	0	0	0	0
balance	1	x	0	1	0.33
shape	1	1	x	2	0.66

Precision Pairwise Comparison Chart					
-------------------------------------	--	--	--	--	--

	grip	width	Length	Results	weight
grip	x	1	1	2	0.66
width	0	x	1	1	0.33
length	0	0	x	0	0

Control Pairwise Comparison Chart							
	grip	Length	width	balance	shape	results	weight
grip	x	1	1	1	1	4	0.4
length	0	X	0	0	0	0	0
width	0	1	x	0	0	1	0.1
balance	0	1	1	x	0	2	0.2
shape	0	1	1	1	x	3	0.3

1/8/2009



finger guard get in the way of cutting

limit rotation

- Finger guard get in way? → limit rotation
- ϕ of handle too large in middle? → like the black ordered scalpel
- Issues with fingers slipping onto blade → cut the front of the
- Is enough grip?
- Is there a design for off, all the weight is cut the front of the

Appendix B: Concept Drawings from 3-3-2 Exercises

11/8/2009

how the back end is angled
shape more of a curve than a bump?
handle back is a good idea but might be hard to set an angle that will
many hands
ing it tapering will cause the fingers to slip

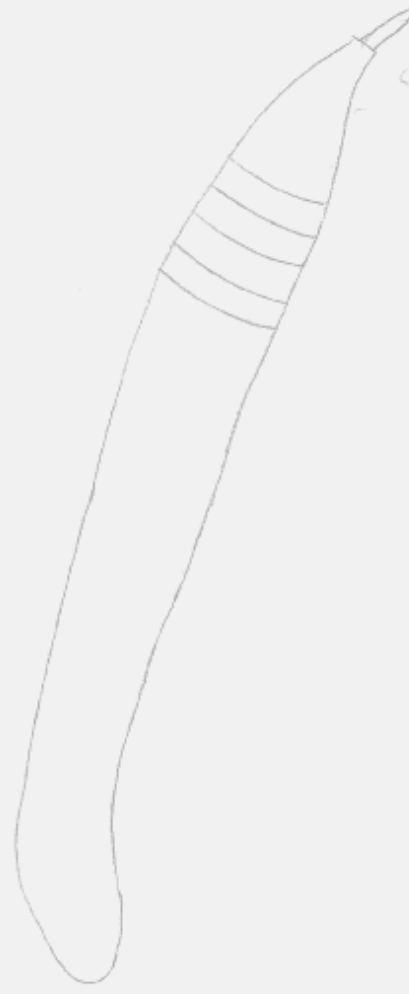

is this curve part of
the scapell? if so, what
is the purpose of the
bump?

V8/2009

37

back end possibly too narrow

textured grip good idea compared to grooves
aid to determine if angled handle will be necessary



11/8/2007

39

is too big for comfortable pencil grip
take how it's angled a bit

2 end might be awkward on web of hand
as with tapering



11/8-2009



- seems too circular
- nice how it expands
as it goes back

- exclusive to right
hand
- smoothing out the
size transitions
would remove edges
- how does back to
middle transition occur
- shape a lifetime

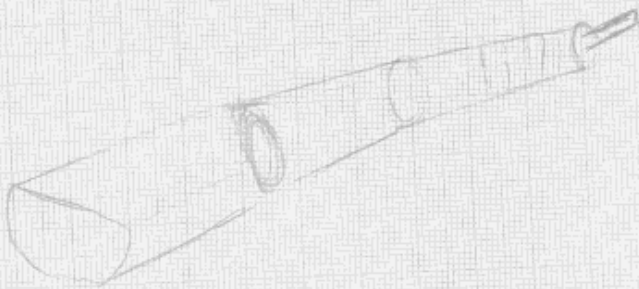

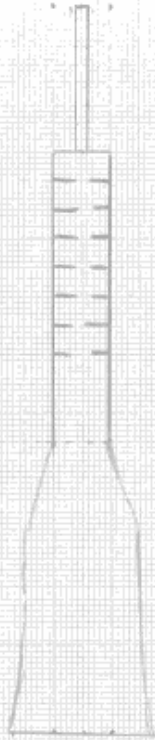

- doesn't work with every hand w/c diff hand sizes
- handle ends a bit out of holding blade
- good to rest on wrist area

- right-hand exclusive
- fits out limits hand sizes that find it comfortable if handle is too short
- grip possibility too narrow
- not round at end may be bad for control

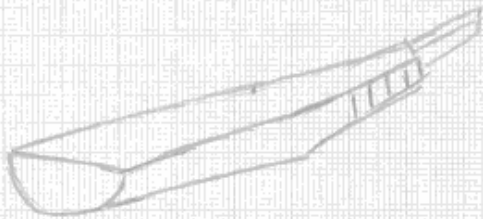

Handwritten signature or scribble.

11/8/2009

Pilot G-2
Pen Grip



- he described pen as too thin
- completely circular might not have as much control
- good grip?

- diameter is possibly too small
- where is the grip supposed to be? tip or thicker area?

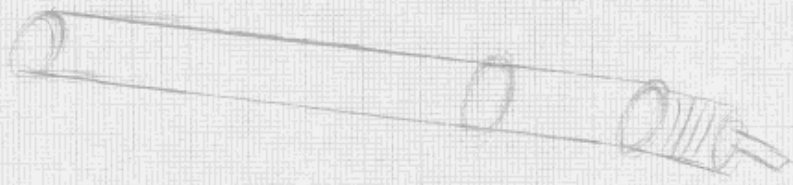



design created utilizing aspects of the
3-3-2 concept designs for the
M2Q2 conference

(A)

11/19/2009!

is too pointy on ends
ok orientation is the back of the blade?



handle cross section

the cross section assuming
the round end where you
grab it.

rotation within grip?



handle cross section

- easy to hold
- seems uncomfortable

curved top, bottom

flat side



handle cross section

seems the same as
standard scalpels

is no
for
to



wide

length
of



cross section
of handle

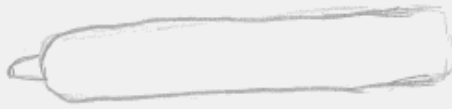

no contours
↳ is this helpful at all?

11/19/2009

How rounded are the sides?
↳ shall circle? shallower?



wider, rounded sides
with flat tops

no contours
↳ how is this different from a surgical
intraoral knife?



circular, finger
block all the way
around

what will the
flat top do?

like the texture

finger block
might be awkward

might be awkward
surgeon
is to rotate
due because
tapering

↳ in not sure how effective
the curve would be
↳ want a trial to test it

circular base,
tapers in middle with
more rectangular
Section, Finger block



11/19/2009



- ① seems kind of wide
- ② Wide at the blade end, Dunn put his fingers on the blade, might be awkward
- ③ Fat middle might balance the scalpel
 - cannot put fingers near point X, where Dr. Dunn places bottom finger sometimes
 - middle section looks too wide, might be awkward

11/19/2009

cross-section



nonagon



- Don't like the sharp edges
- seems simple
- nonagon shape interesting
- tapering @ back looks like it won't fit many hand sizes

Appendix C: M2D2 Poster

Ergonomic Scalpel Handle Design for Accurate Incision



Peter Brown¹, Jennifer Dahlmann¹, Nicholas Palumbo¹

Advisors: Dr. Raymond Dunn², Dr. Krystyna Gielo-Perczak³, Dr. Christopher Sotak¹

¹Departments of Biomedical Engineering, Worcester Polytechnic Institute, Worcester, MA 01609

²Department of Plastic Surgery, University of Massachusetts Medical School, Worcester, MA 01655



Introduction

The flat designed scalpel handle has been commonly used for the past century, and is made with either a metal or plastic handle (Fig. 1). Typically, plastic scalpel handles are for one time use while stainless steel scalpel handles are autoclaved (re-sterilization) and used repeatedly. Depending on the type of surgery and depth of incision, a surgeon can attach a different blade to the scalpel handle.



Fig. 1. Currently used metal (top) and plastic (bottom) scalpel handles at UMass. Note the flat design and inherent grip for creating curved incisions.

With the current scalpel handles on the market, the surgeon is forced to compensate for design limitations. This is particularly true for procedures involving circular, elliptical, or beveled incisions. Surgeons have limited ability to rotate or tilt the scalpel handle as required for the operative procedure. Often, surgeons must move their body and adjust their hand grip in less stable positions in order to gain access to an optimal cutting angle (Fig. 2). This forces the surgeon to move their arm and shoulder into an awkward position to make a precise incision. Small lesion removal is a common procedure involving curved and beveled cuts. The surgeon cuts an ellipse around the lesion, and excises the region. Symmetrical cuts on either side of the lesion provide the best possibility for ideal wound healing and minimizing scar formation.



Fig. 2. Examples of common, awkward hand positions that may be used in surgery.

Business Potential

According to the national center for health statistics, 41.3 million inpatient and 31.5 million outpatient surgeries were performed in 1999 [1]. In an surgical operation setting, scalpels are the most commonly used tool. Typical scalpel handles vary in price ranging between \$9.25 to \$20.00 [2]. Many procedures require multiple scalpels with different blade types. Between the scalpels that are reused and those that are disposed of after a single use, it is not unreasonable to assume an average of one new scalpel per procedure, meaning that 72.8 million scalpel handles would have been necessary to perform the procedures in 1999 alone. If the scalpel handle sleeve can be sold at \$10 then this would create a market of \$728 million domestically, with larger possibilities in the global market.

Our Design cont.

The contoured shape was specifically designed to fit in the hand for optimal comfort and control. Near the blade is a narrow region for gripping without requiring any pinching to maintain control of the handle. The sleeve widens in the middle to provide proper balance. This allows for greater hand-to-sleeve contact along the length of the handle without forcing the hand into awkward or uncomfortable positions. The handle tapers inward toward the back end which guides the handle to rest on the web of the hand, further increasing stability.

Commercial Alternatives

UMass surgeons have identified the problem that currently used scalpel handles are awkward to use for small lesion removal. The scalpel handles used by the surgeons are thin with flat edges which, when used to create non-linear incisions, are difficult to hold and limit the surgeon's control. Many of the products available to surgeons from distributors such as VWR and Fisher Scientific do not address this problem and sell scalpel handles which are minimally different than the ones used by UMass surgeons.



Fig. 5. Commercially available scalpel handles[3].

Although scalpel handle modifications are currently available (Fig. 5), they do not address the problem of increasing the surgeon's control for circular or elliptical incisions.

Conclusions

Along with improving the overall comfort of the scalpel handle, it is our belief that the precision and control a surgeon has during a surgical procedure will be increased through the use of our novel scalpel handle design. Additionally, the scalpel handle will be compatible with the current operating room environment and feature a design that is both cost effective to manufacture and can be sterilized for repeated use.

References

1. Carol J. DeFranco MD, Christine A. Lucas MPH, M.S.W, Verita C. Bule DPH, Goleonally K. 2006 National Hospital Discharge Survey. In *National Health Statistics Report*, vol. 5, July 2006 edition pp. National Center for Health Statistics, 2005's.
2. *Standard Scalpel*. National Center for Health Statistics, 2005's.
3. *Standard Scalpel*. <http://www.carlos.com/standardscalpel.asp>



Fig. 3. Scalpel handle sleeve design

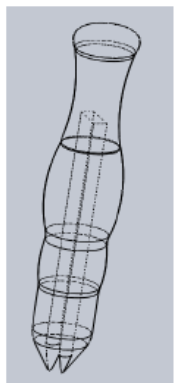

Fig. 4. Internal view of the sleeve showing the cavity in which a scalpel handle will be inserted



Fig. 5. The right picture displays several different scalpel blades. From top to bottom they are 15, 11, 10, and 22 blades. On the right is a demonstration of our product with color coded scalpel handles for blade identification.

Our Design

This product is currently in the prototype phase, and preliminary testing and validation has been started with surgeons at UMass. The product can be sold as either a full scalpel handle (Fig. 3) or as a handle sleeve which is fully compatible with the standard flat scalpel handles used throughout the United States (Fig. 4).

There are a variety of materials that can be used for the sleeve, including Polypropylene, PTFE, and Polycarbonate. These materials are currently undergoing evaluation for properties that meet the design and sterilization constraints of the operating room. The grip is a high-friction surface that reduces the risk of the scalpel handle slipping during surgery. In addition, the handle or handle sleeve comes in a variety of colors for easy blade identification (Fig. 5).

The design features a circular cross-section. Not all commercially available designs allow the surgeon to hold the scalpel handle at different angles in their hand stably, for circular, elliptical, and beveled incisions. This forces the surgeon to adjust their arms and shoulders in unstable positions. A round profile allows the handle to be held comfortably at any level of rotation and allows the surgeon to twist the handle for curved incisions.

Appendix D: M2D2 PowerPoint Presentation

Ergonomic Scalpel Handle Design for Accurate Incision

Peter Brown¹, Jennifer Dahmann¹, Nicholas Palumbo¹
Advisors: Dr. Raymond Dunn², Dr. Krystyna Gielo-Perczak¹
Dr. Christopher Sotak¹

¹Department of Biomedical Engineering, Worcester Polytechnic Institute, Worcester, MA 01609
²Department of Plastic Surgery, University of Massachusetts Medical School, Worcester, MA 01605



Medical Device Inventor Showcase
November 24th 2009

Background

- Common Scalpel Handles
 - Awkward hand positioning
 - Limited circular, elliptical and beveled incision control



Medical Device Inventor Showcase
November 24th 2009

Background

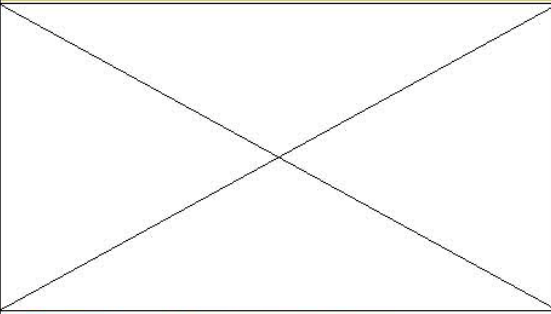

Medical Device Inventor Showcase
November 24th 2009

Background

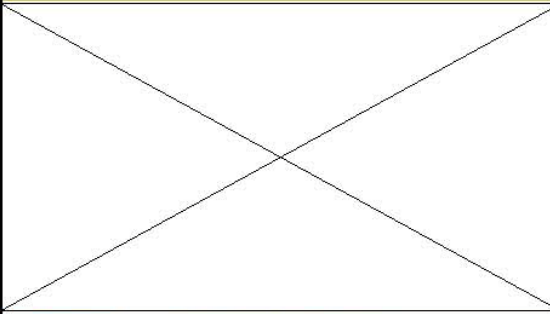

Medical Device Inventor Showcase
November 24th 2009

Design



- Improved
 - Scalpel control
 - Grip



Medical Device Inventor Showcase
November 24th 2009

Design

- Sleeve or independent handle
- Color coded handle for blade identification

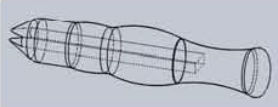

Medical Device Inventor Showcase
November 24th 2009

Business Potential

- 72.8 million procedures performed in the US in 1999
 - 1 scalpel used per procedure
 - \$10
 - 728 million dollar market



Medical Device Inventor Show case
November 24th 2009

Commercial Alternatives



Medical Device Inventor Show case
November 24th 2009

Timeline

- Prototyping
 - Dec. 17th
- Design Testing & Validation
 - Jan. 14th - Feb. 5th
- Design Optimization
 - Feb. 8th – March 5th



Medical Device Inventor Show case
November 24th 2009

Research & Business Team

- Ergonomic Scalpel Handle Design for Accurate Incision
 - WPI
 - UMass Plastic Surgery
 - UMass Lowell



Medical Device Inventor Show case
November 24th 2009

Contact Information

- Peter Brown
 - pbrown@wpi.edu (508) 982-6346
- Jennifer Dahlmann
 - jdahlmann@wpi.edu
- Nick Palumbo
 - npalumbo@wpi.edu (508) 414-6750
- Dr. Raymond Dunn
 - Raymond.Dunn@umassmemorial.org



Medical Device Inventor Show case
November 24th 2009

Appendix E – All Alternative Designs

Images are not to scale

Standard Scalpel



M2D2 Design

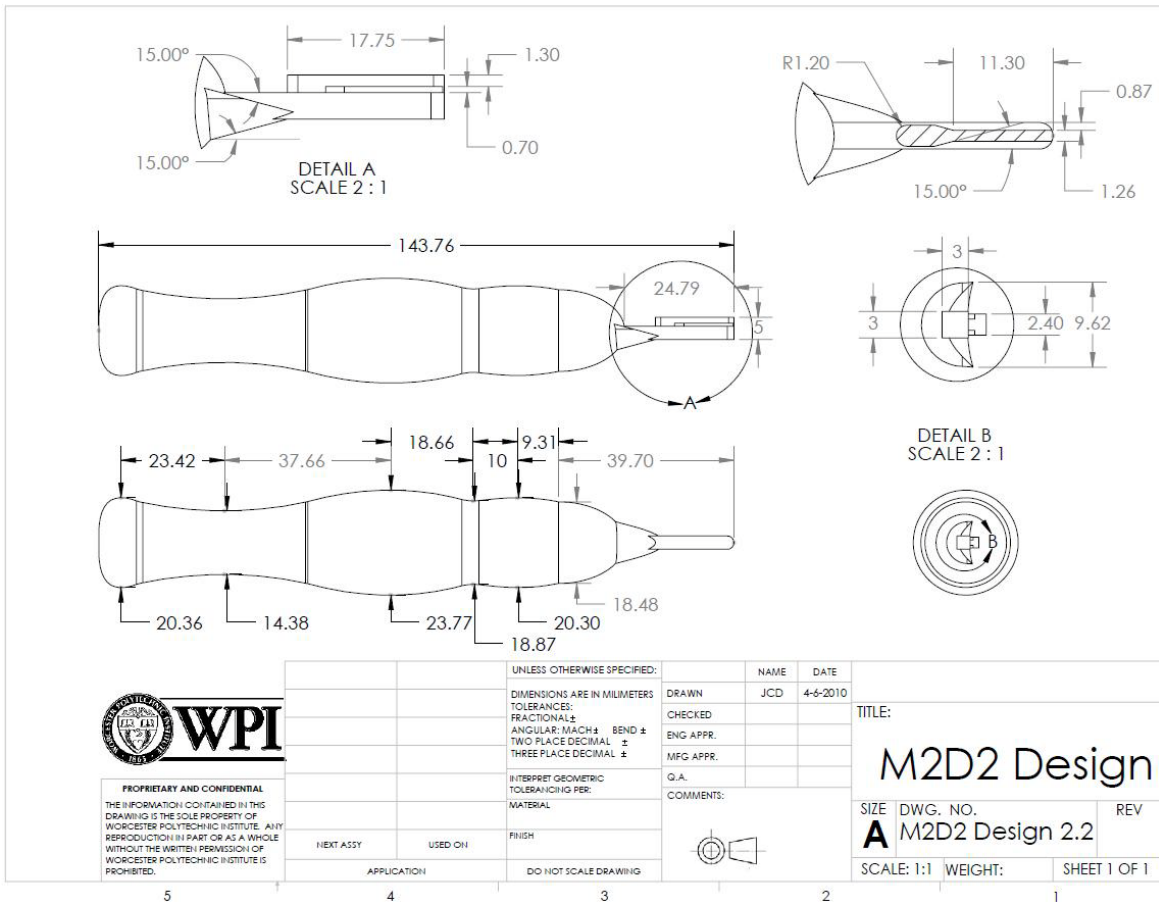
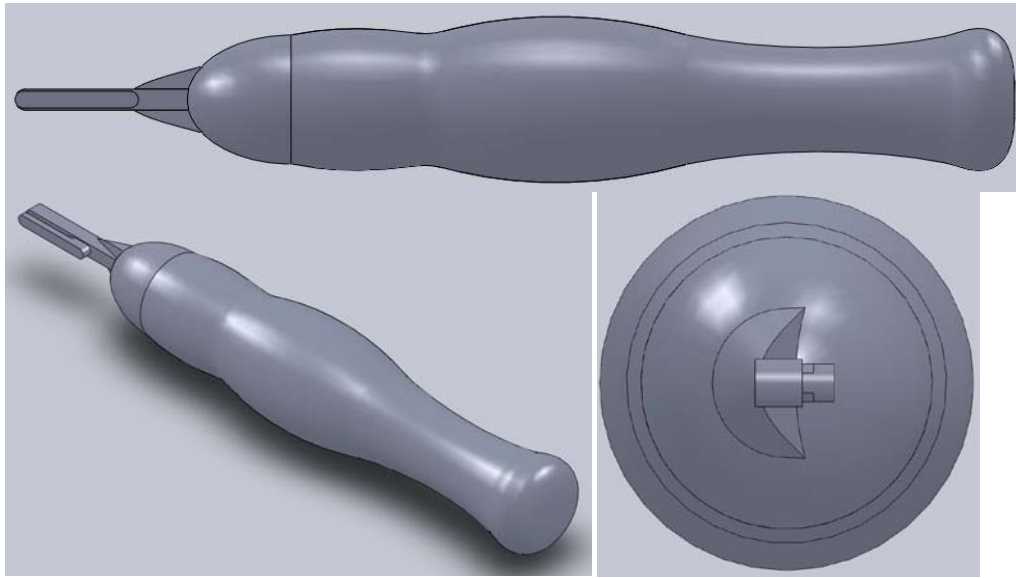

Alternative 1

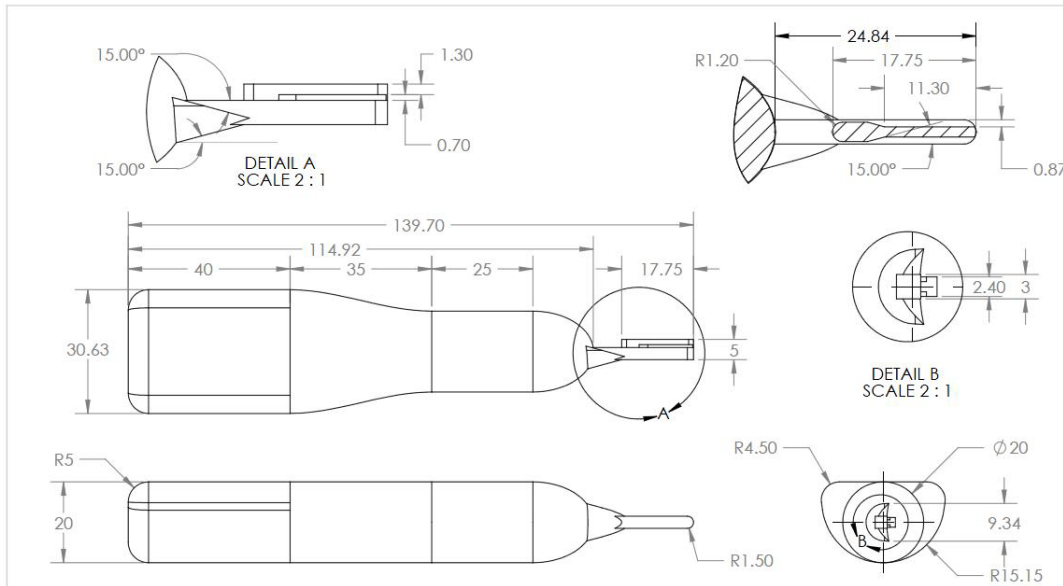
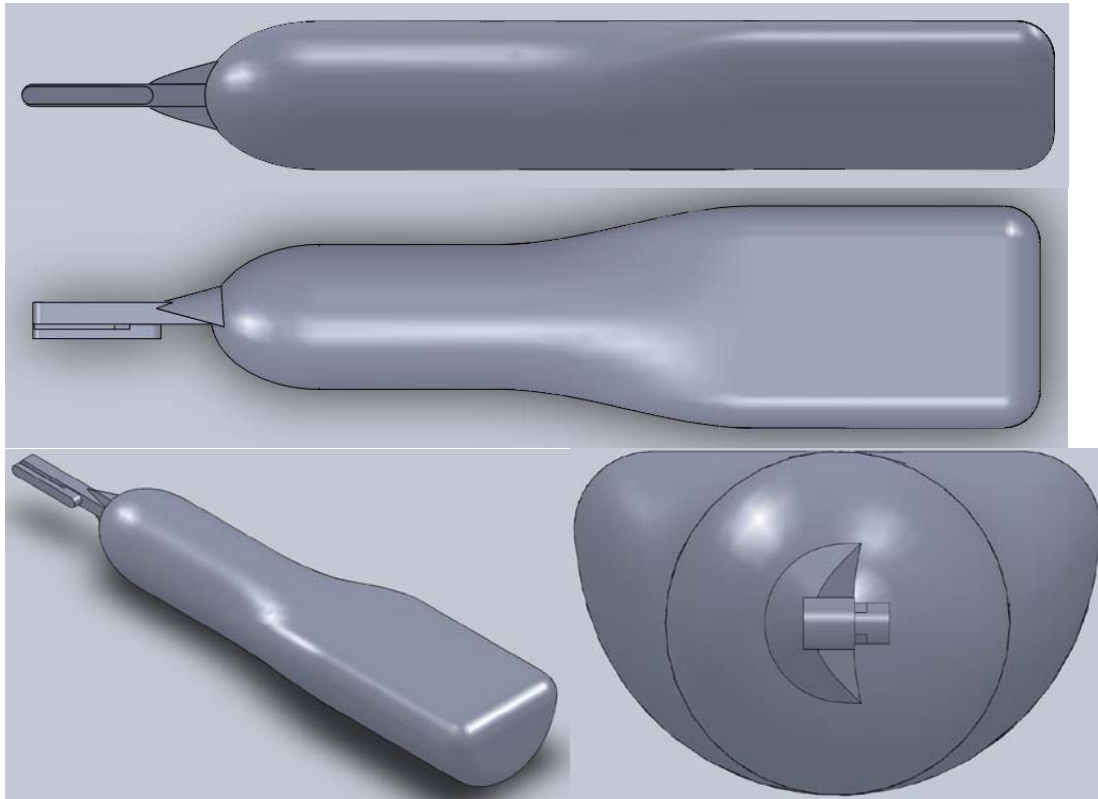

PROPRIETARY AND CONFIDENTIAL
 THE INFORMATION CONTAINED IN THIS
 DRAWING IS THE SOLE PROPERTY OF
 WORCESTER POLYTECHNIC INSTITUTE. ANY
 REPRODUCTION IN PART OR AS A WHOLE
 WITHOUT THE WRITTEN PERMISSION OF
 WORCESTER POLYTECHNIC INSTITUTE IS
 PROHIBITED.

		UNLESS OTHERWISE SPECIFIED:	NAME	DATE
		DIMENSIONS ARE IN MILLIMETERS	JCD	4/6/2010
		TOLERANCES:	DRAWN	
		FRACTIONALS:	CHECKED	
		ANGULARS: MACH ± BEND ±	ENG APPR.	
		TWO PLACE DECIMAL ±	MFG APPR.	
		THREE PLACE DECIMAL ±	Q.A.	
		INTERPRET GEOMETRIC TOLERANCING PER:	COMMENTS:	
		MATERIAL		
		FINISH		
		DO NOT SCALE DRAWING		

TITLE:	
Alternative 1	
SIZE	REV
A	
DWG. NO.	
SCALE: 1:1	WEIGHT:
	SHEET 1 OF 1

Alternative 2

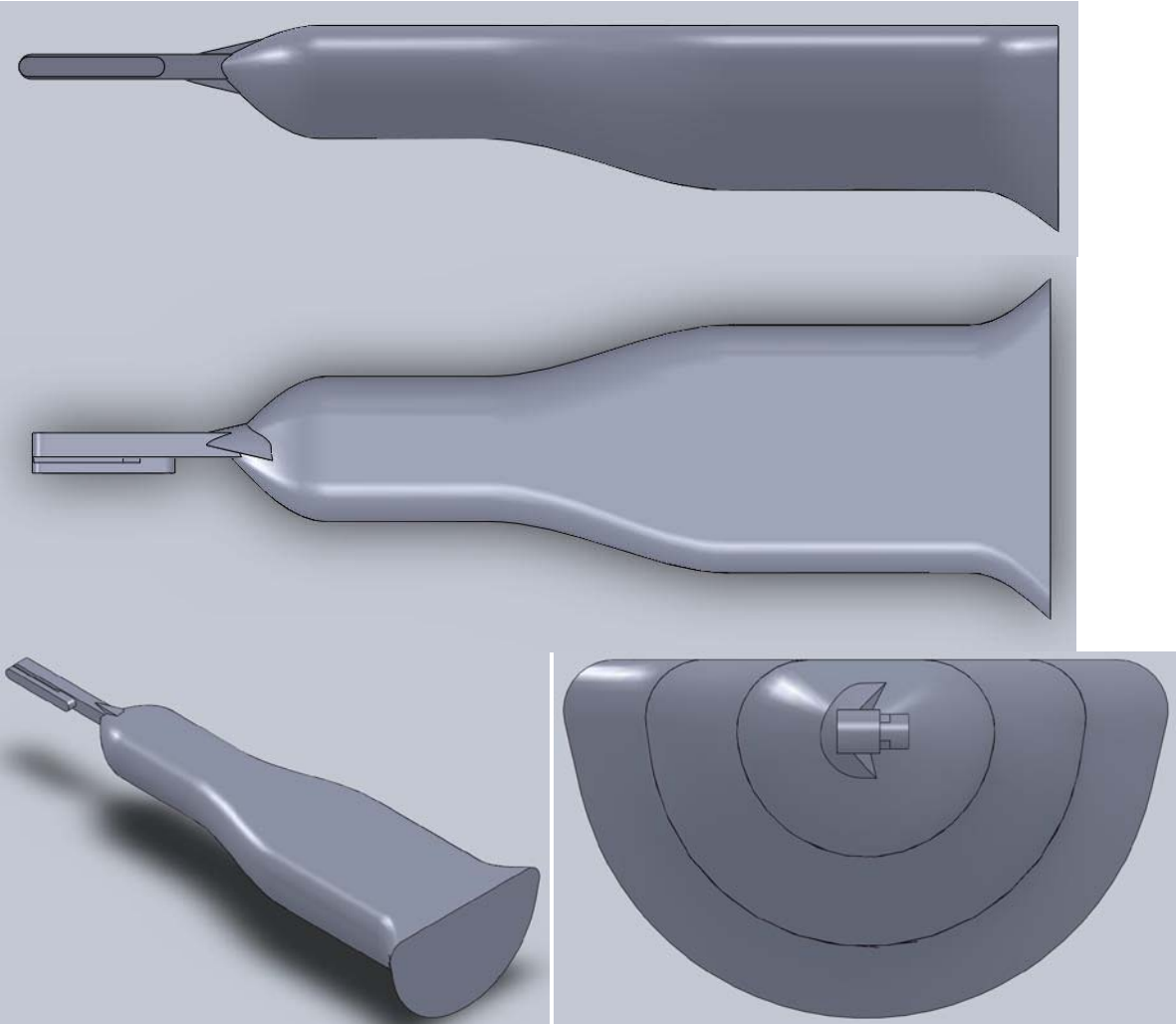

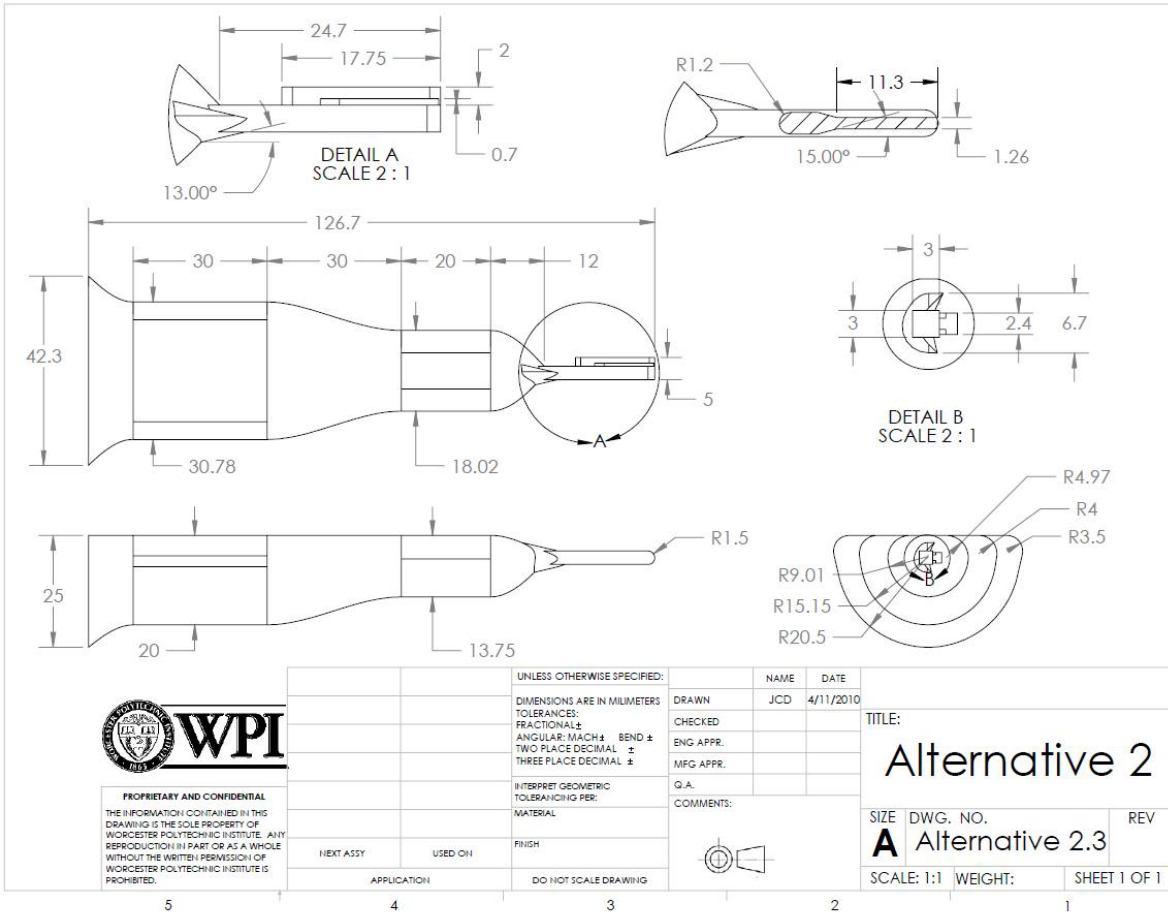

PROPRIETARY AND CONFIDENTIAL
 THE INFORMATION CONTAINED IN THIS DRAWING IS THE SOLE PROPERTY OF WORCESTER POLYTECHNIC INSTITUTE. ANY REPRODUCTION IN PART OR AS A WHOLE WITHOUT THE WRITTEN PERMISSION OF WORCESTER POLYTECHNIC INSTITUTE IS PROHIBITED.

		UNLESS OTHERWISE SPECIFIED:	NAME	DATE
		DIMENSIONS ARE IN MILLIMETERS	JCD	4/11/2010
		TOLERANCES:		
		FRACTIONAL ±		
		ANGULAR: MACH ±		
		TWO PLACE DECIMAL ±		
		THREE PLACE DECIMAL ±		
		INTERPRET GEOMETRIC TOLERANCING PER:		
		MATERIAL:		
		FINISH:		
		DO NOT SCALE DRAWING		

TITLE:	
Alternative 2	
SIZE DWG. NO.	REV
A Alternative 2.3	
SCALE: 1:1	WEIGHT:
	SHEET 1 OF 1

5

4

3

2

1

Alternative 3

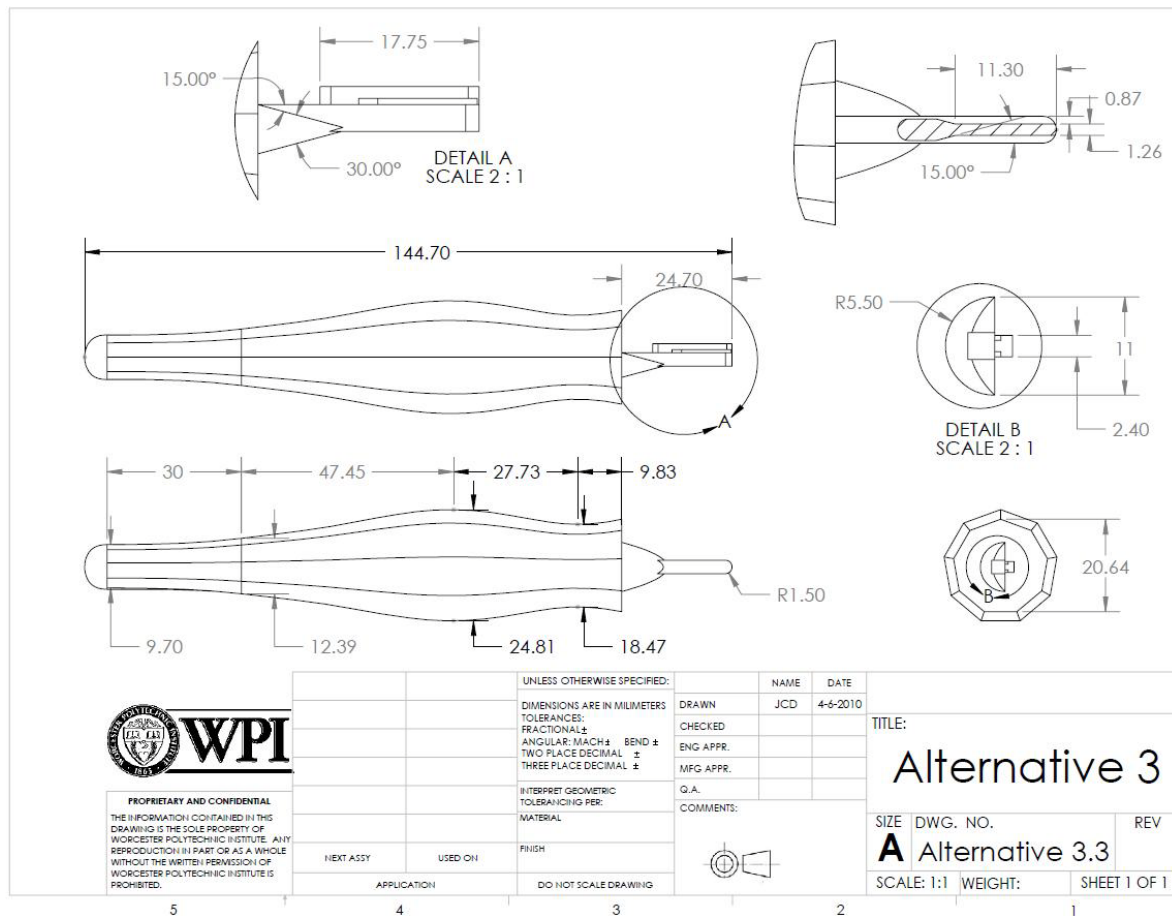
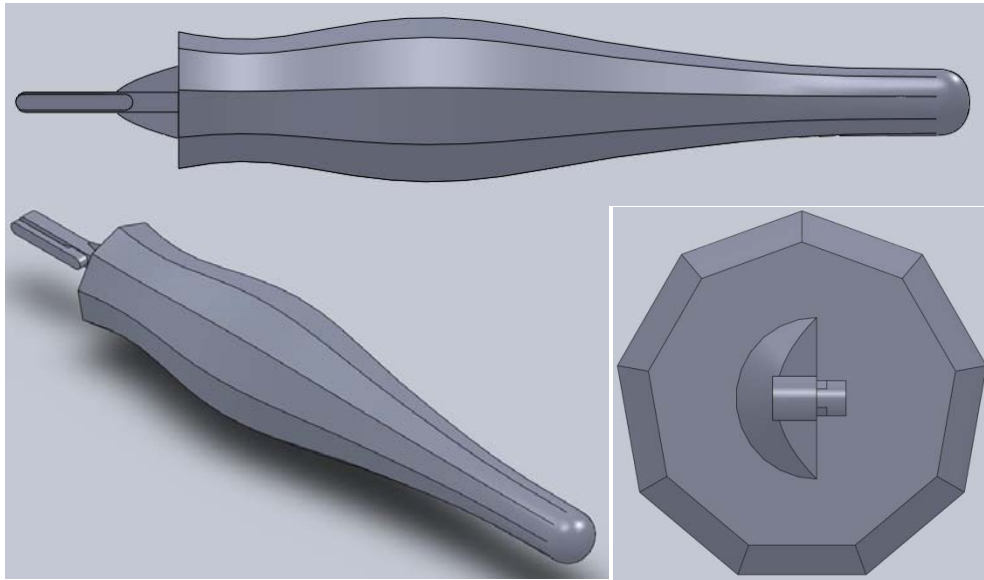

Alternative 5

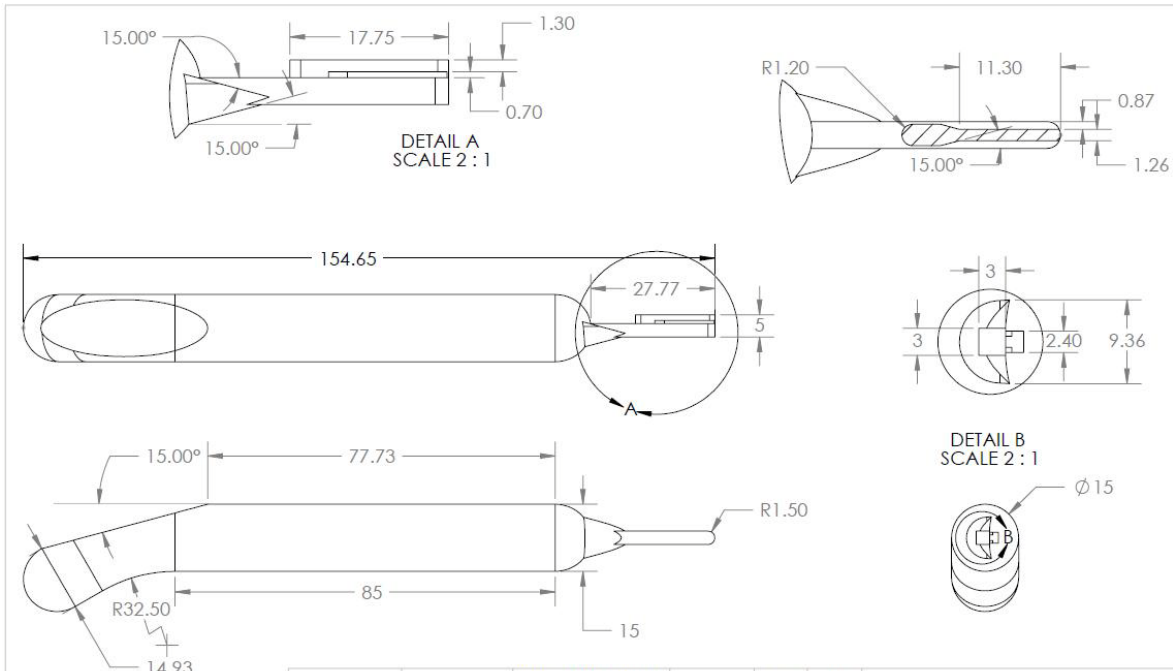
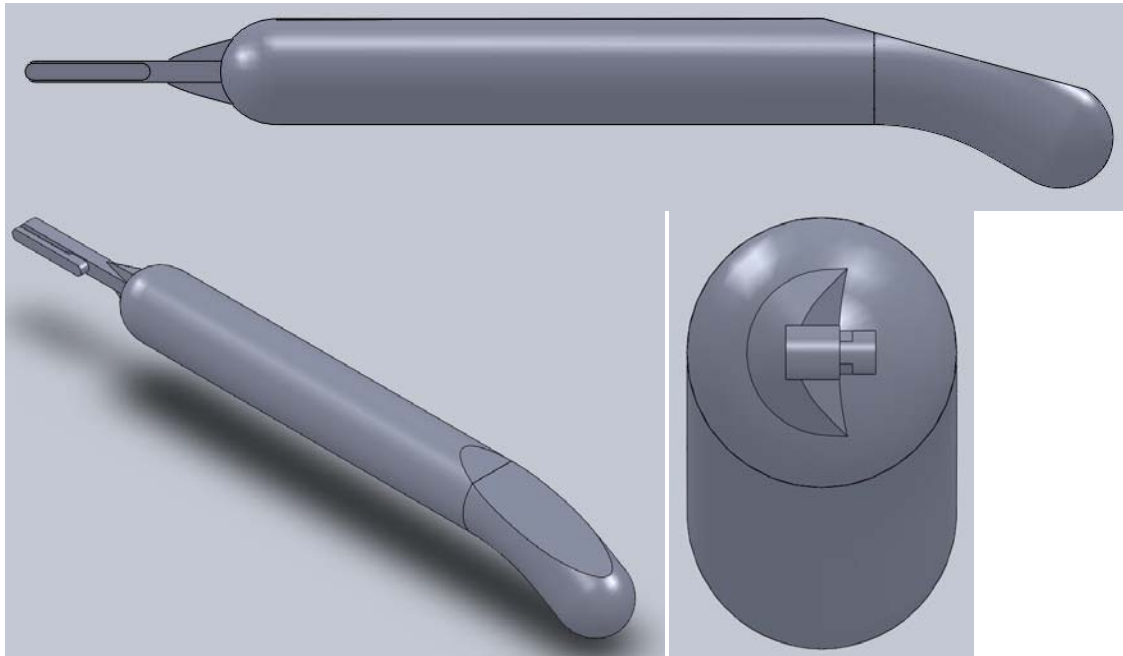

PROPRIETARY AND CONFIDENTIAL
 THE INFORMATION CONTAINED IN THIS DRAWING IS THE SOLE PROPERTY OF WORCESTER POLYTECHNIC INSTITUTE. ANY REPRODUCTION IN PART OR AS A WHOLE WITHOUT THE WRITTEN PERMISSION OF WORCESTER POLYTECHNIC INSTITUTE IS PROHIBITED.

		UNLESS OTHERWISE SPECIFIED:	NAME	DATE		
		DIMENSIONS ARE IN MILLIMETERS	DRAWN	JCD	4/6/2010	TITLE:
		TOLERANCES:	CHECKED			Alternative 5
		FRACTIONAL ±	ENG APPR.			
		ANGULAR: MACH ±	MFG APPR.			SIZE DWG. NO.
		BEND ±	Q.A.			A Alternative 5.2
		TWO PLACE DECIMAL ±	COMMENTS:			REV
		THREE PLACE DECIMAL ±				SCALE: 1:1
		INTERPRET GEOMETRIC TOLERANCING PER:				WEIGHT:
		MATERIAL:				SHEET 1 OF 1
NEXT ASSY	USED ON	FINISH				
APPLICATION	DO NOT SCALE DRAWING					

5 4 3 2 1

Redesign 1

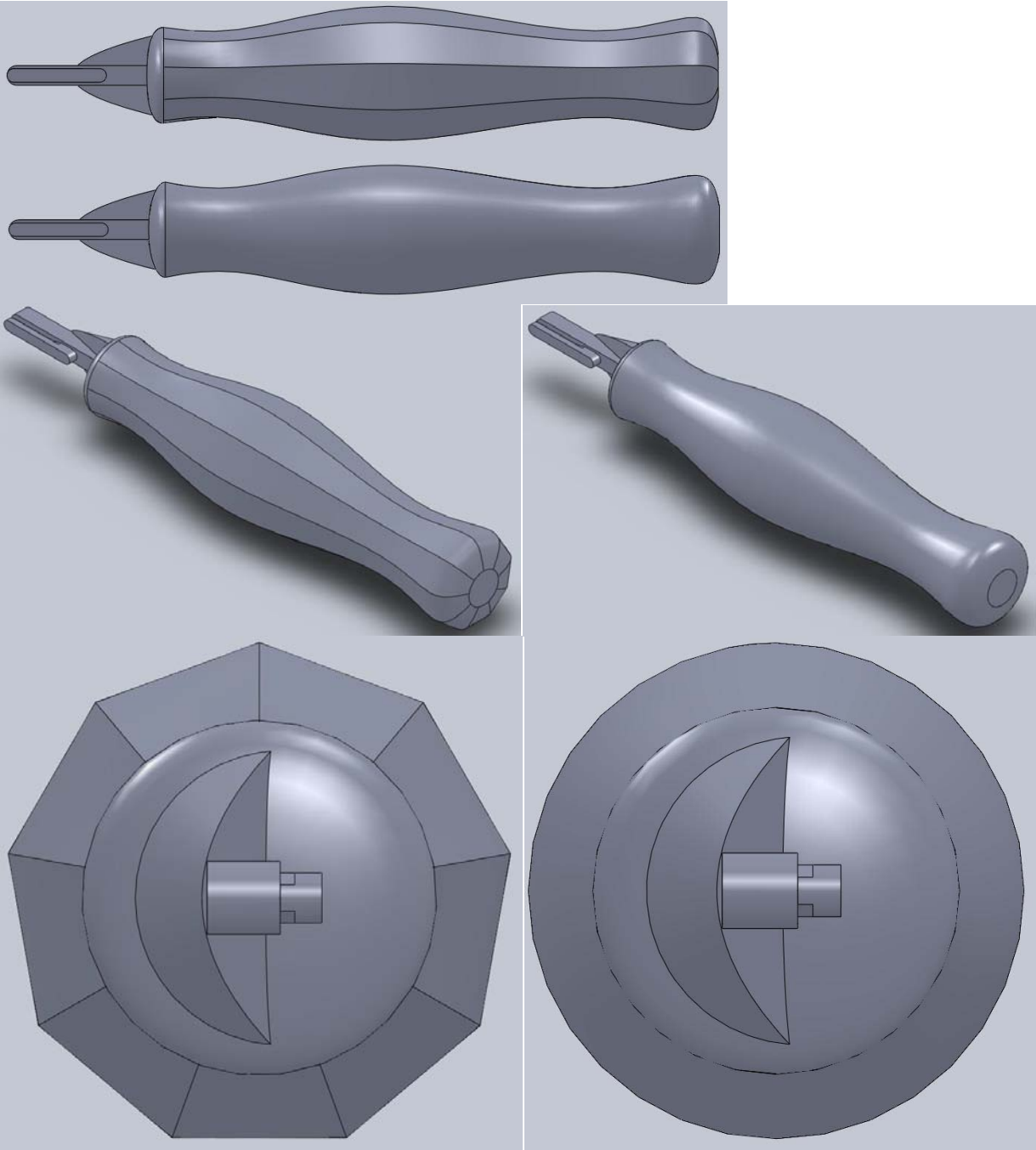

Final Design

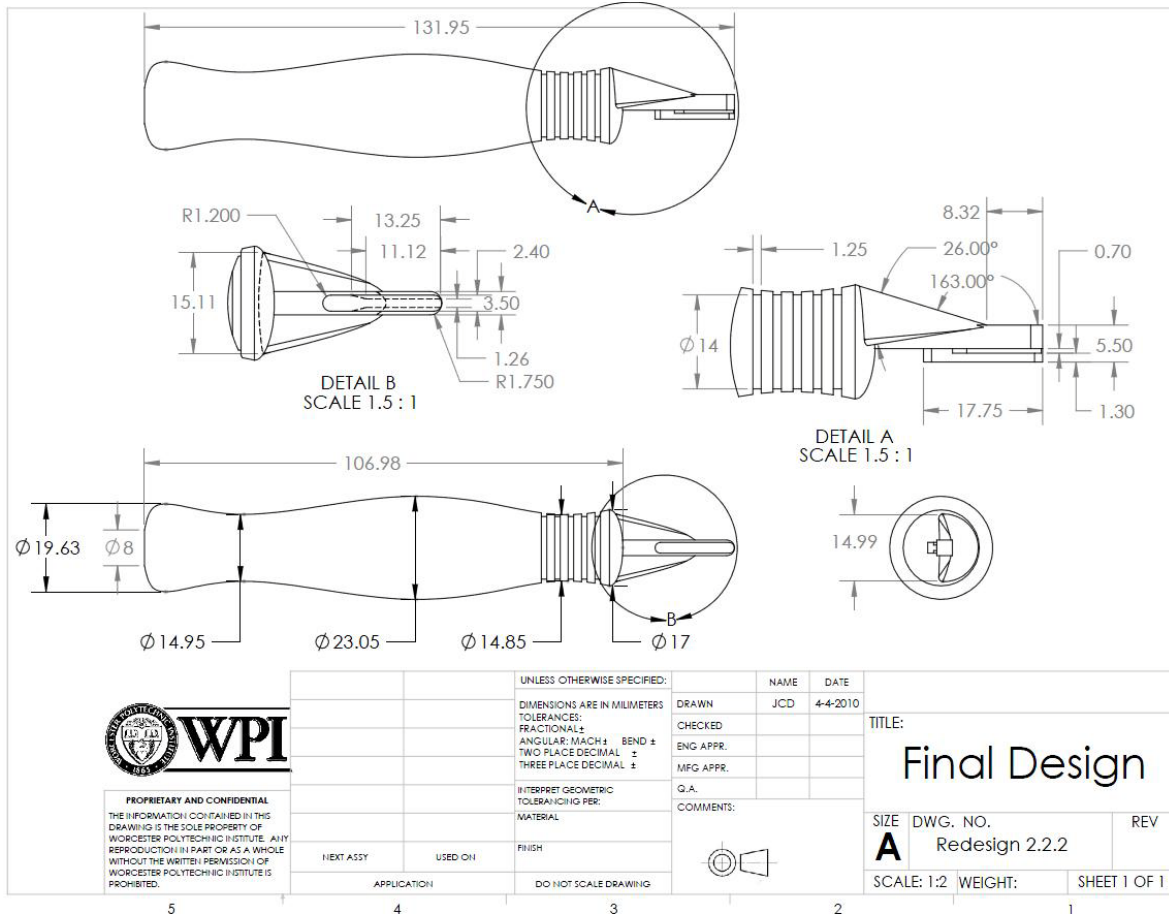
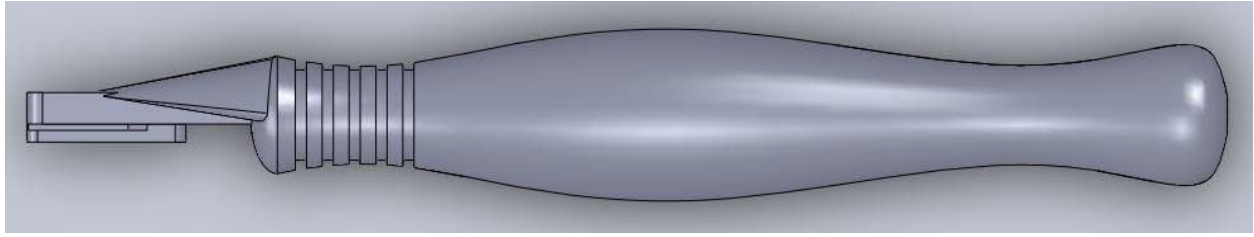

Appendix F: Testing Questionnaire

	Comments		
	Circular Incision	Elliptical Incision	Linear Incision
Support hand position/location			
Grip/ finger position			
Comfort			
Stability			
Control			
Accuracy			
Force to create incision			
Traction			
Balance			
General			

	Rating 1-5 (1 low, 5 high)		
	Circular Incision	Elliptical Incision	Linear Incision
Comfort			
Stability			
Control			
Accuracy			
Traction			
Balance			
Force to create incision			

Appendix G: Testing Data

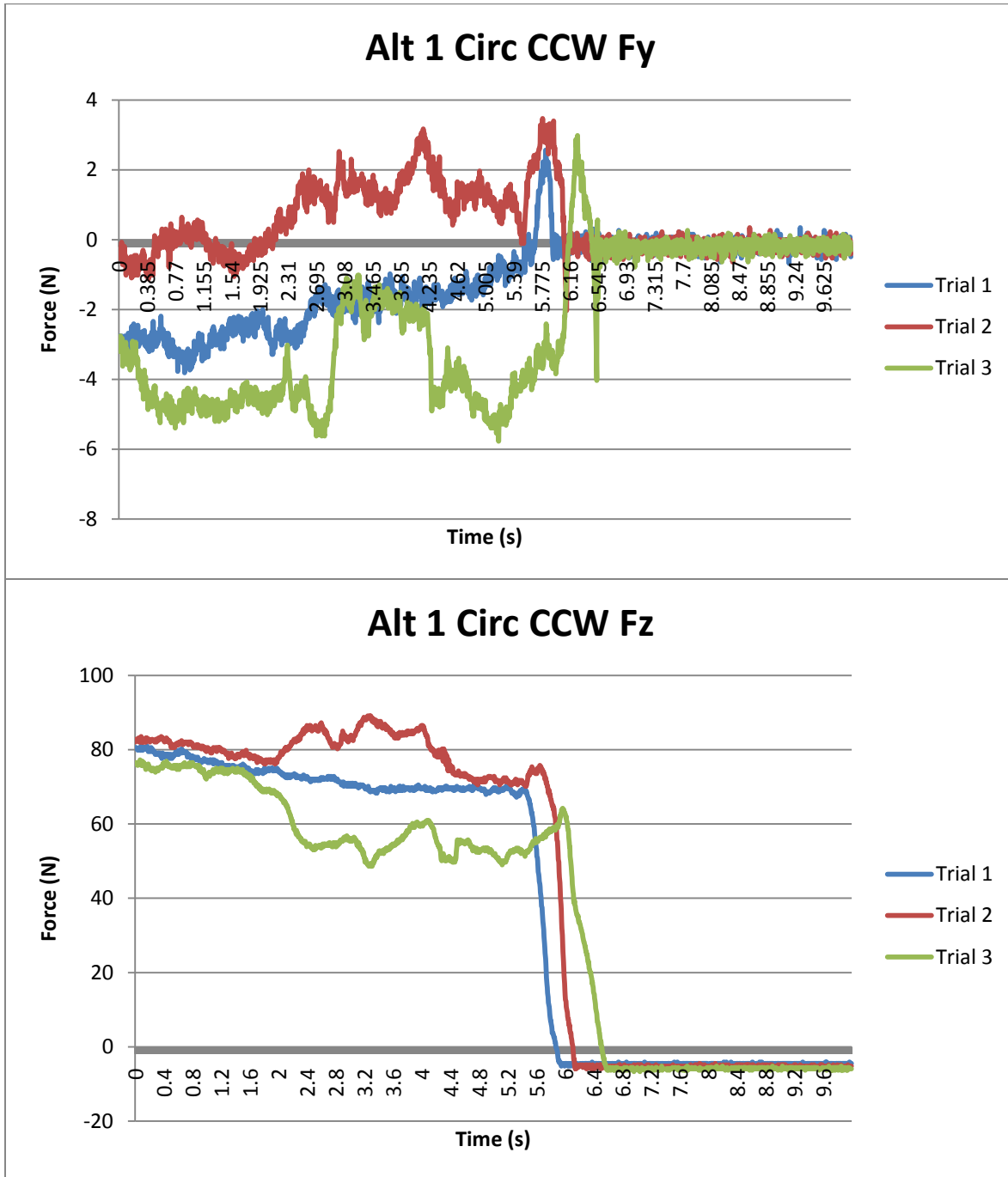

Alt 1 Circ CCW Mx

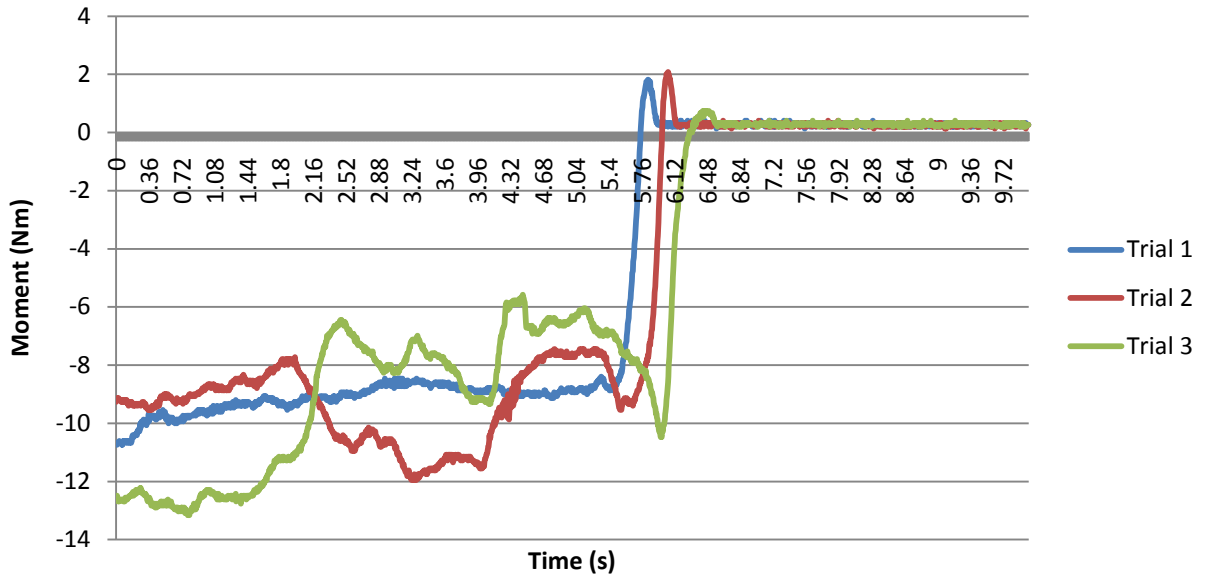

Alt 1 Circ CCW My

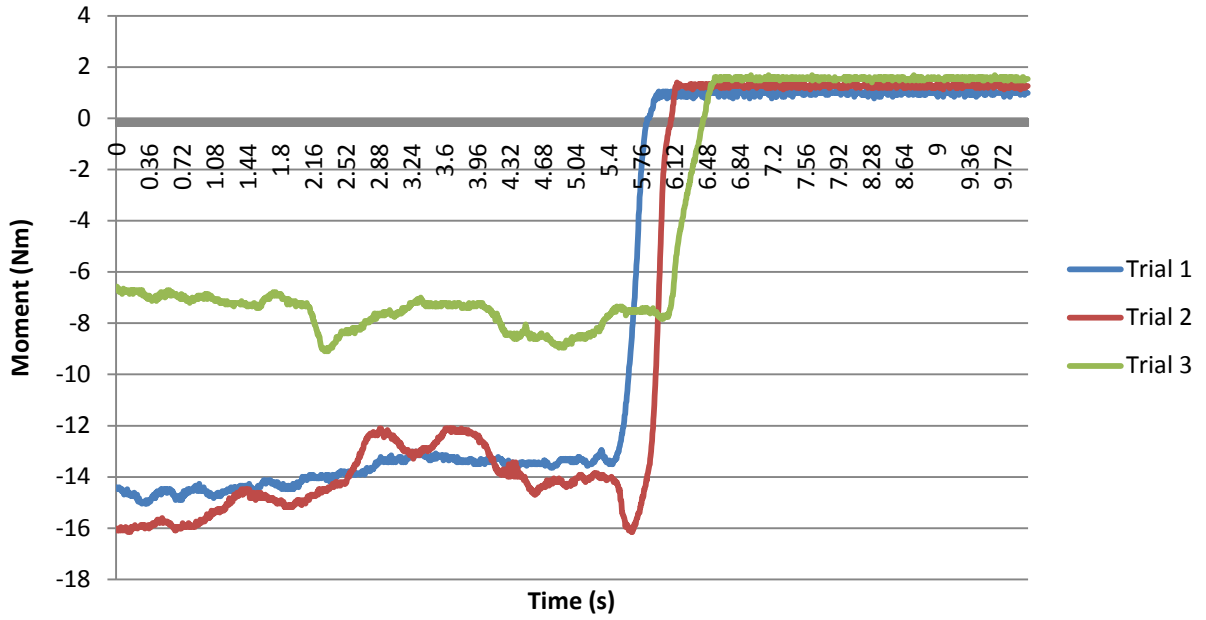

Alt 1 Circ CCW Mz

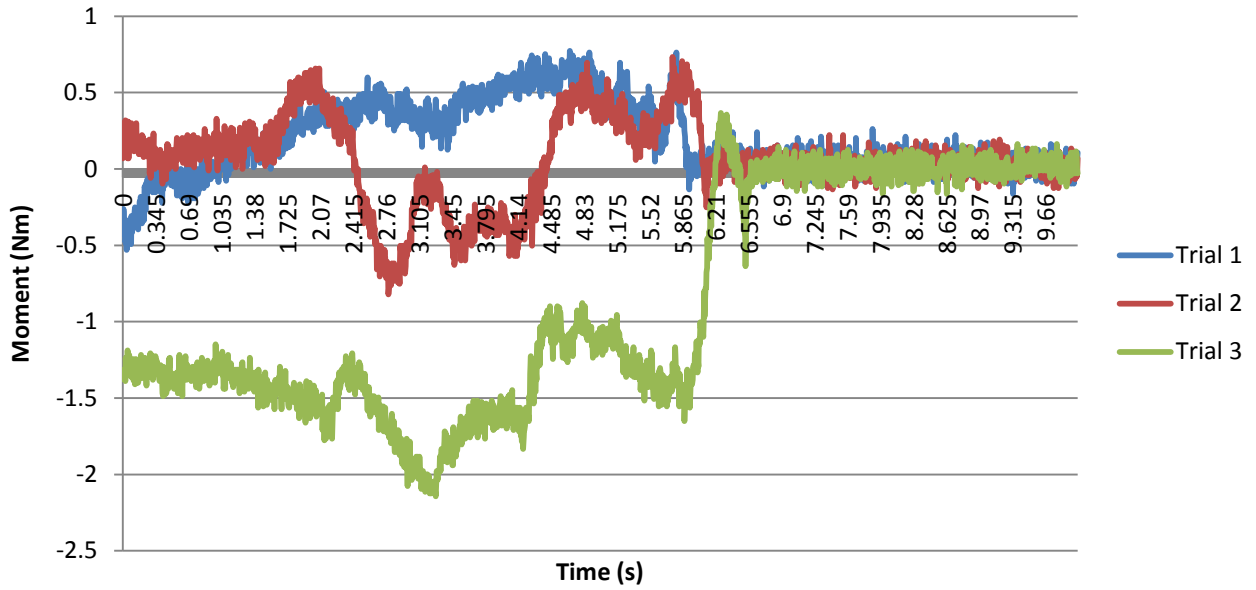

Alt 1 Circ CCW Average Fx

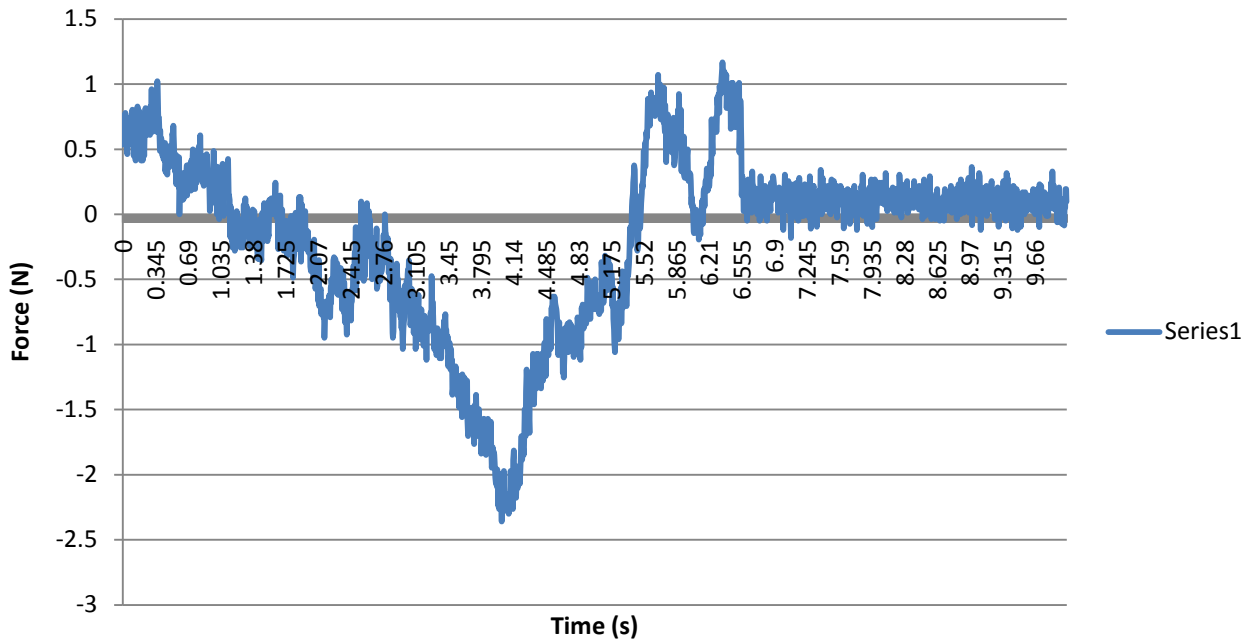

Alt 1 Circ CCW Average Fy

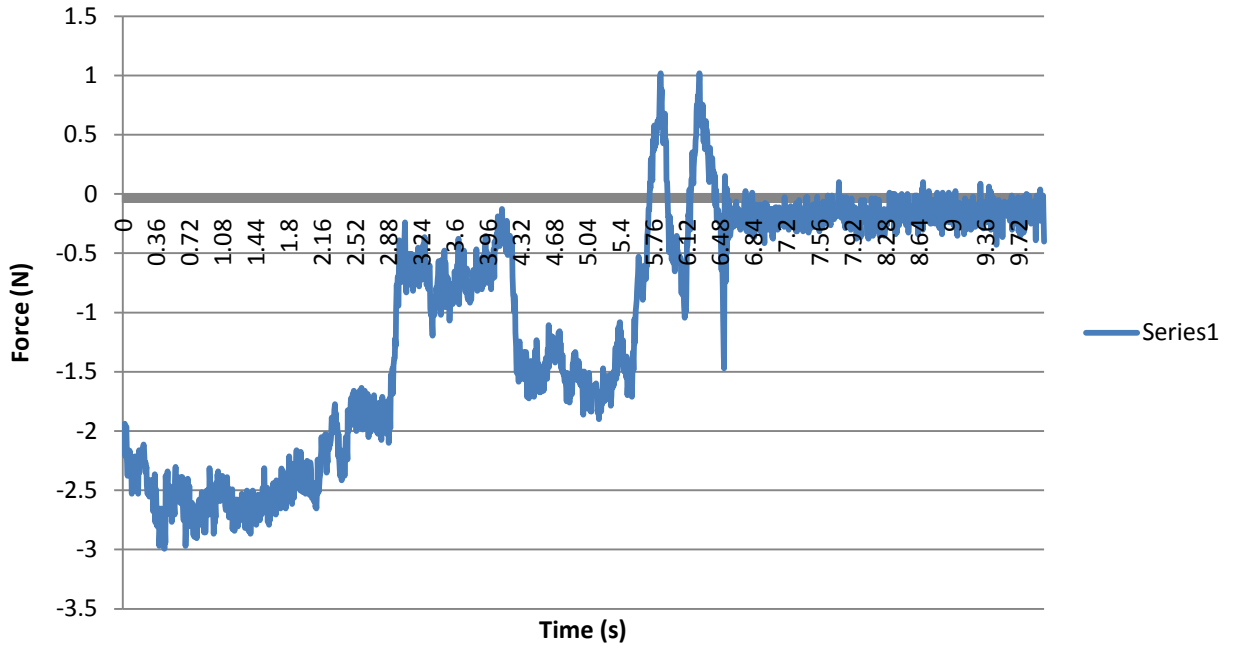

Alt 1 Circ CCW Average Fz

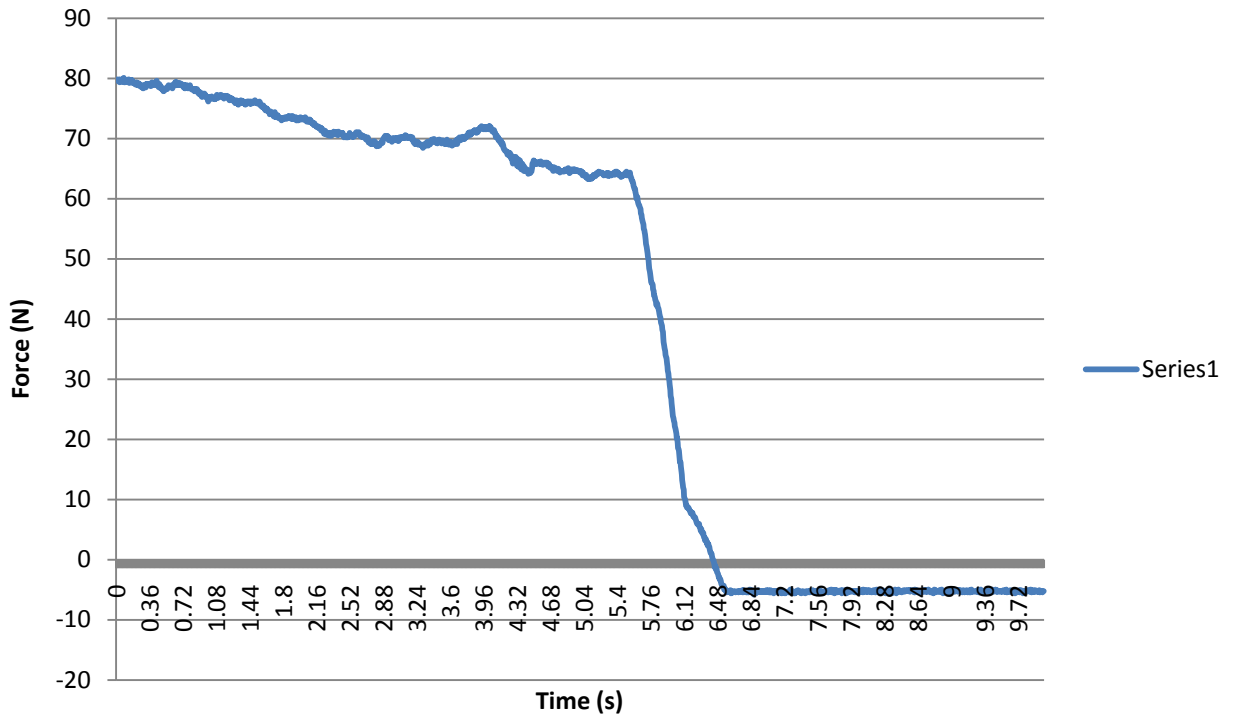

Alt 1 Circ CCW Average Mx

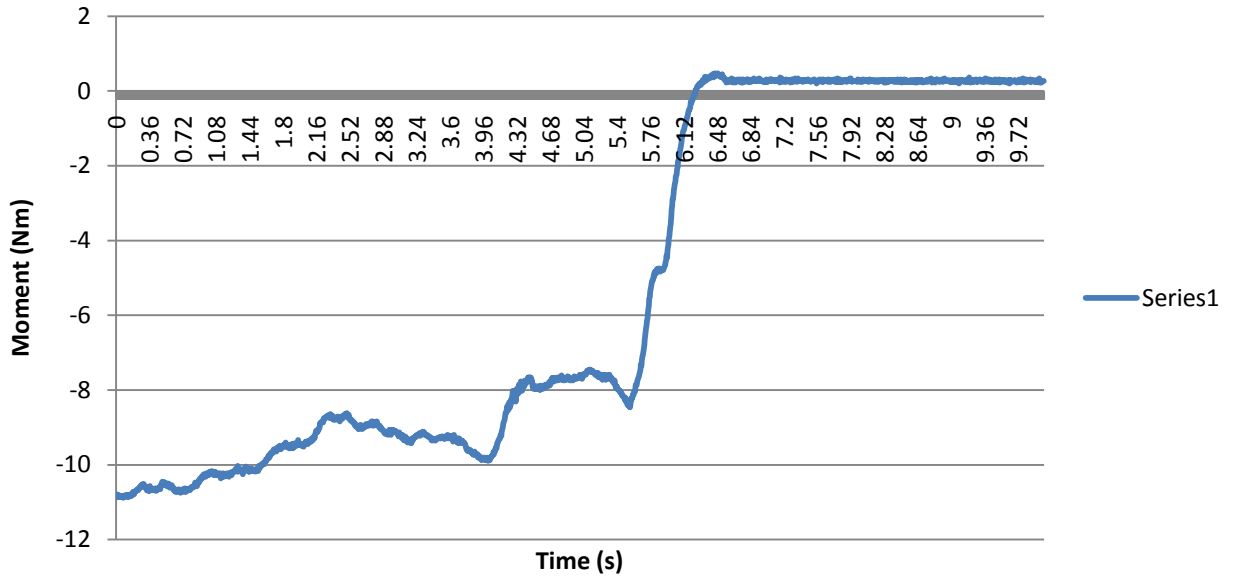

Alt 1 Circ CCW Average My

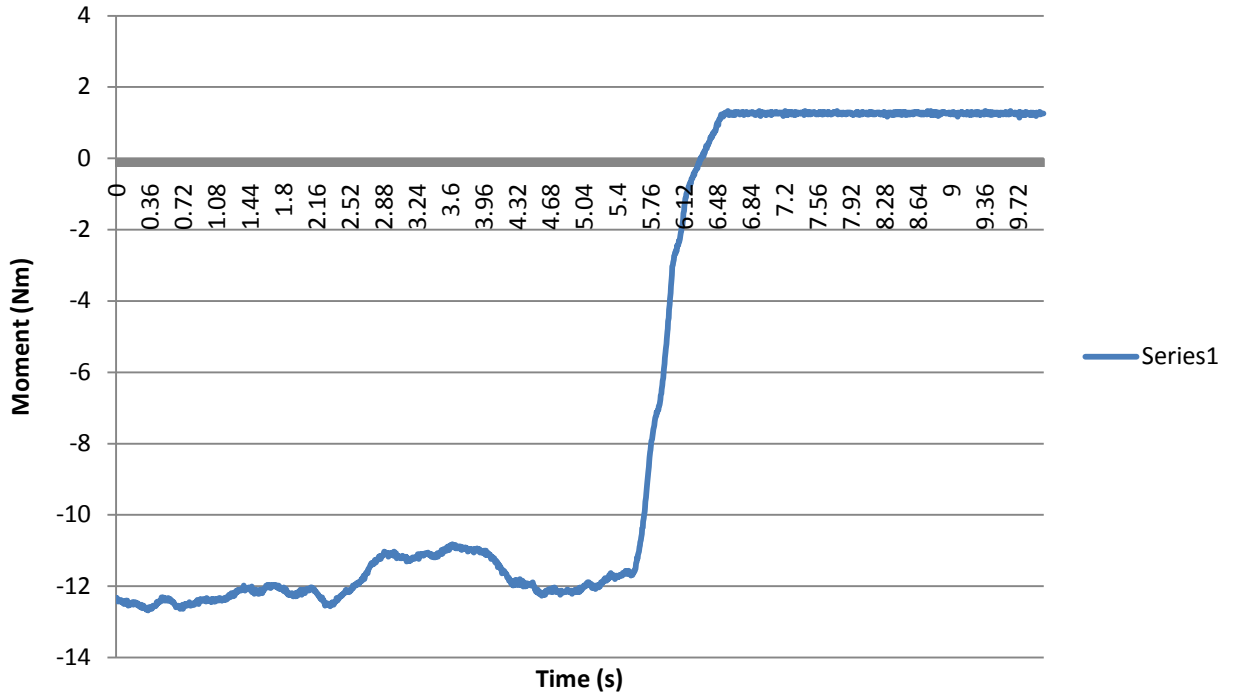

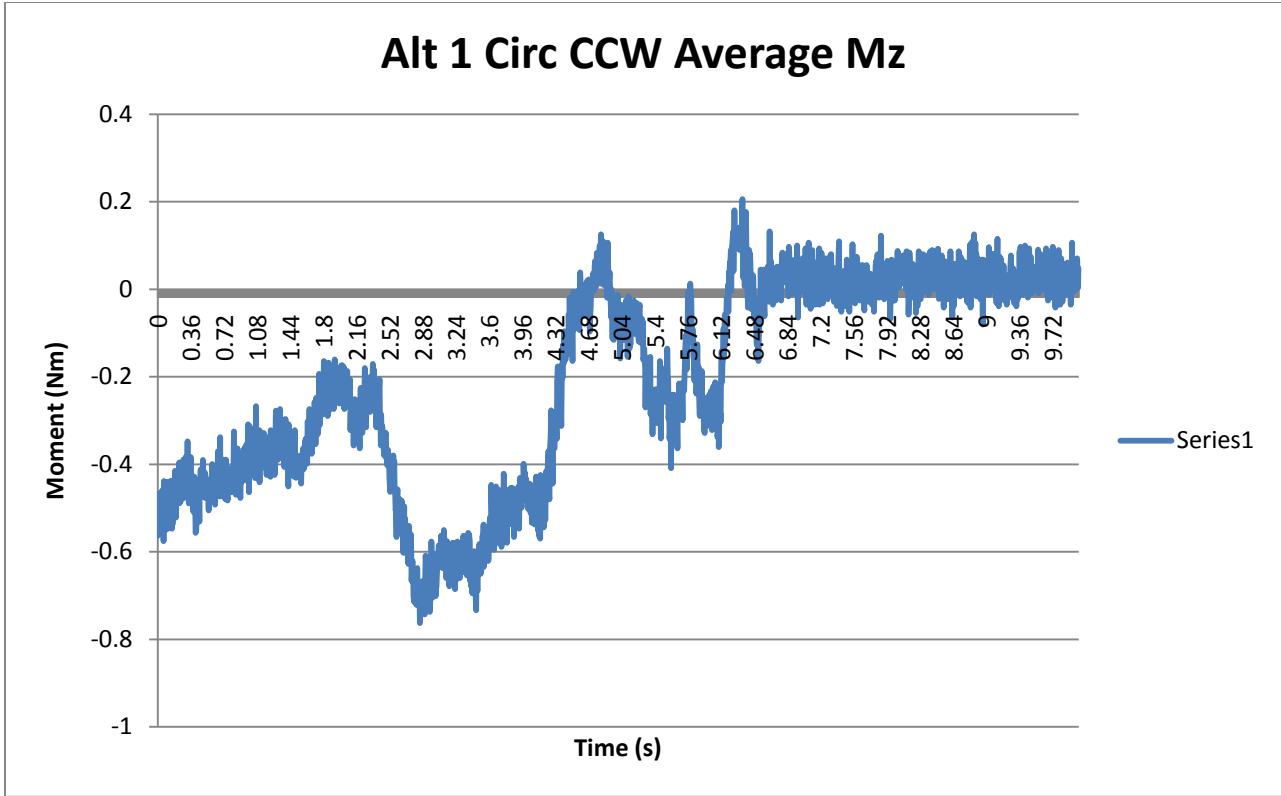

Alt 1 Circ CW Fx

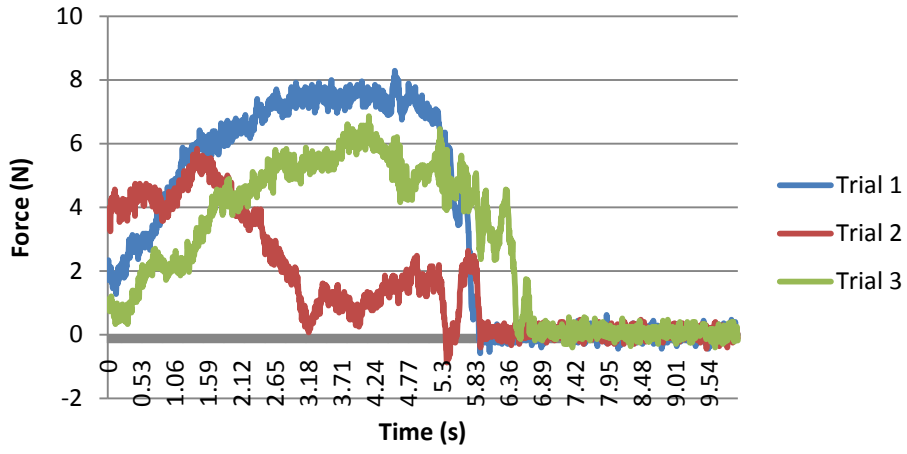

Alt 1 Circ CW Fy

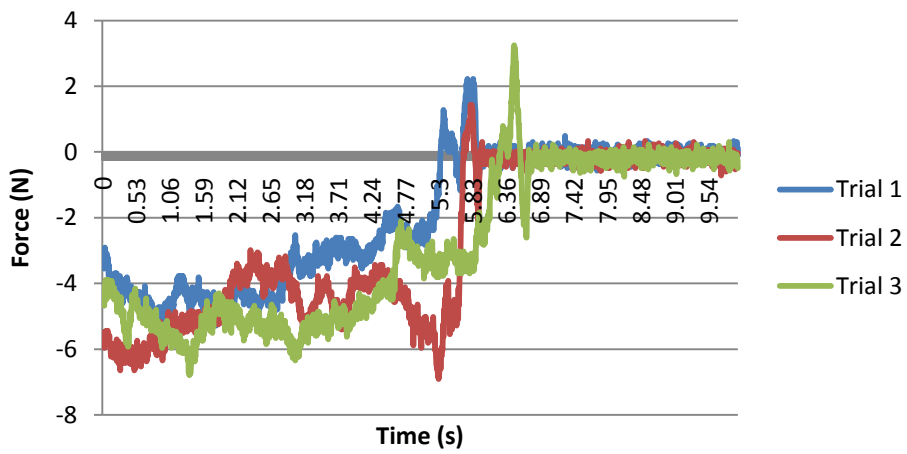

Alt 1 Circ CW Fz

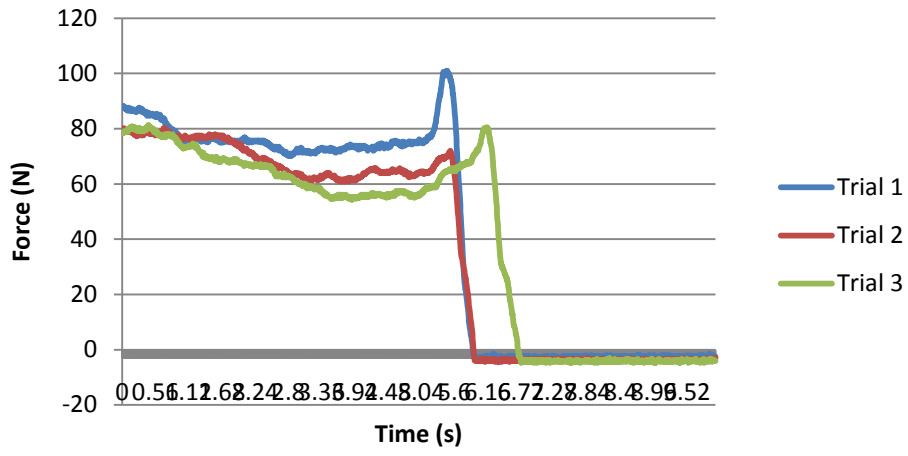

Alt 1 Circ CW Mx

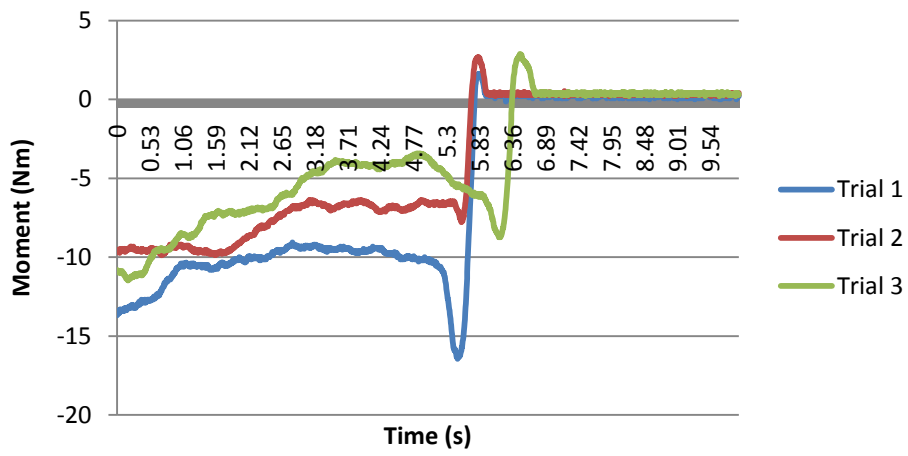

Alt 1 Circ CW My

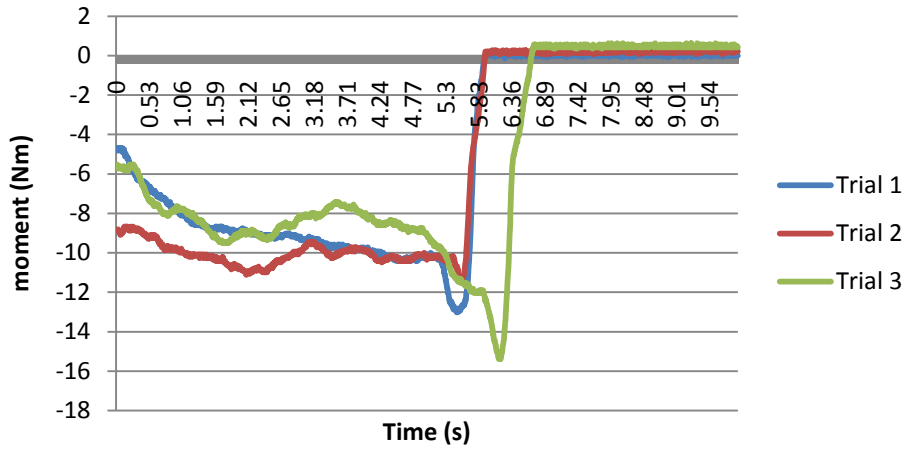

Alt 1 Circ CW Mz

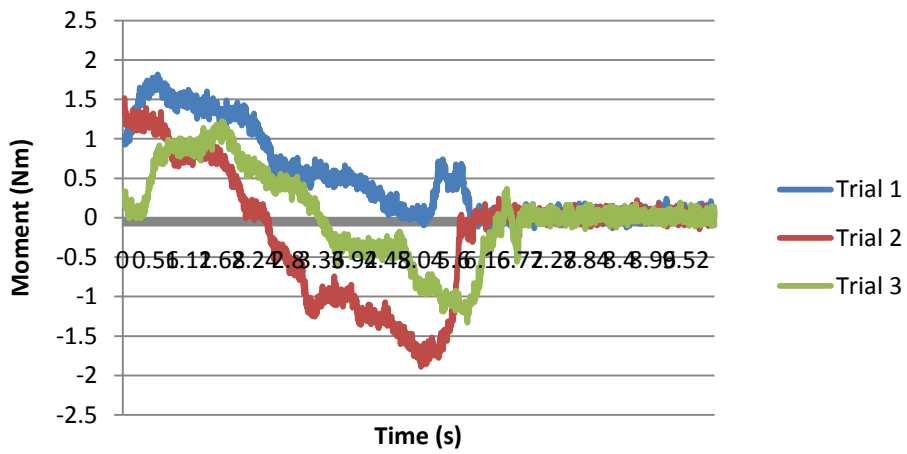

Alt 1 Circ CW Average Fx

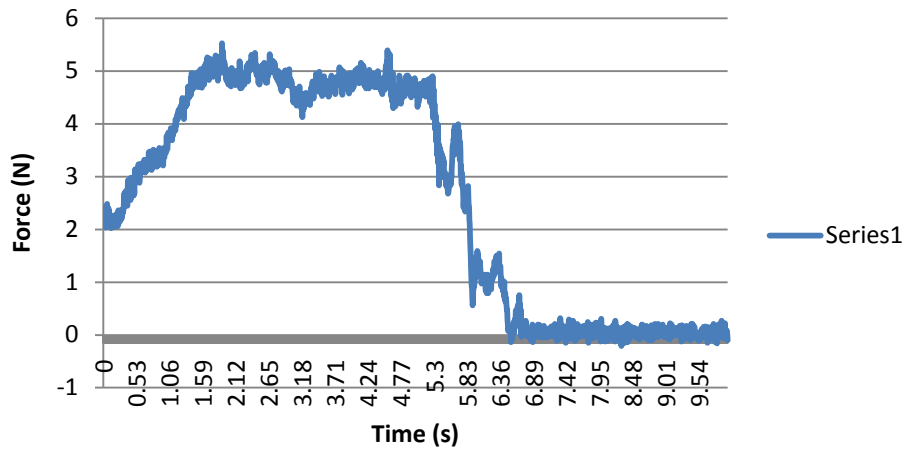

Alt 1 Circ CW Average Fy

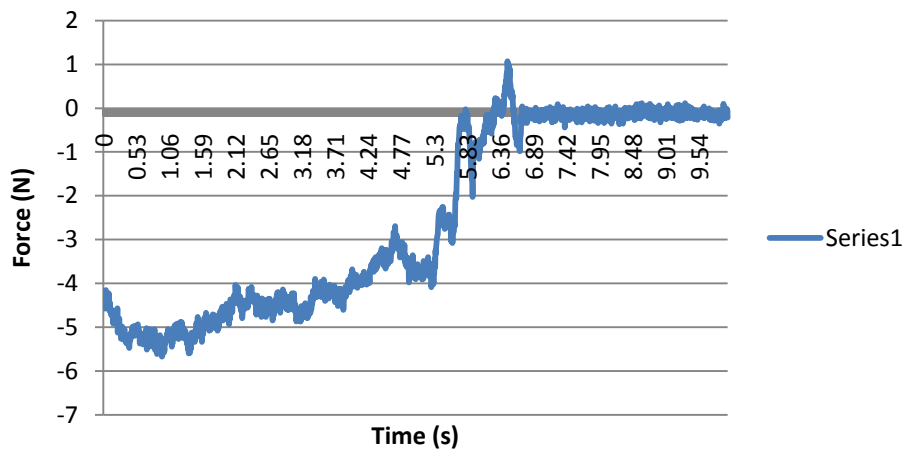

Alt 1 Circ CW Average Fz

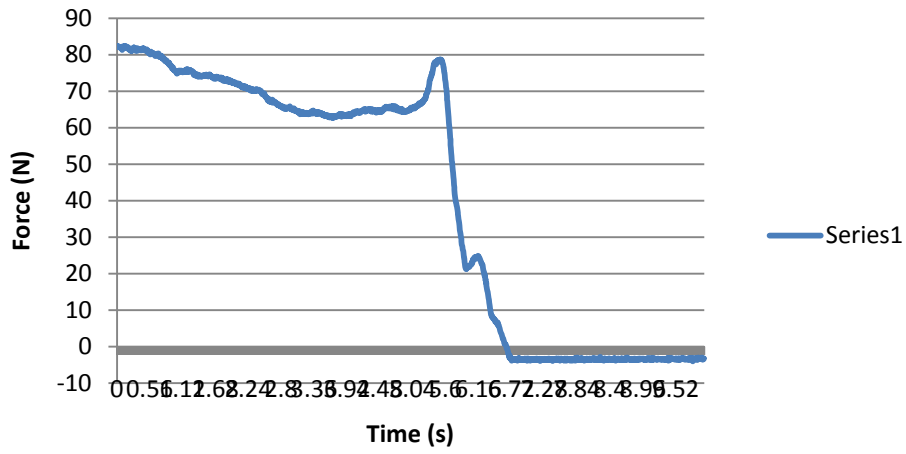

Alt 1 Circ CW Average Mx

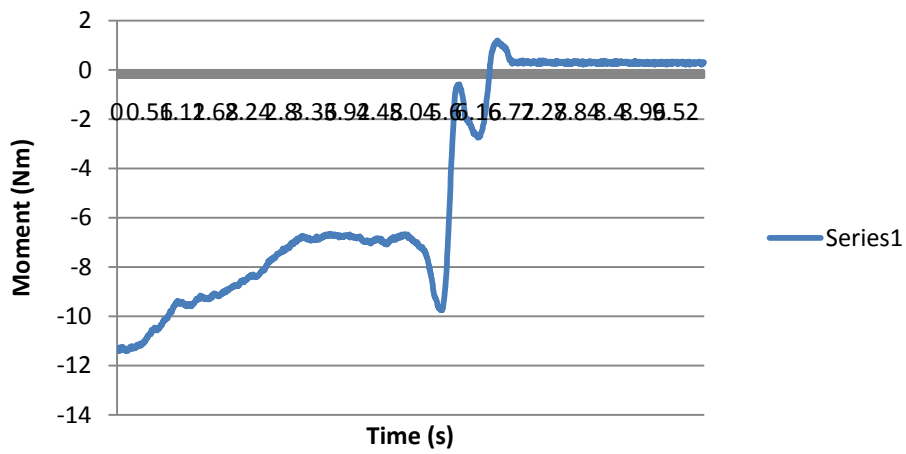

Alt 1 Circ CW Average My

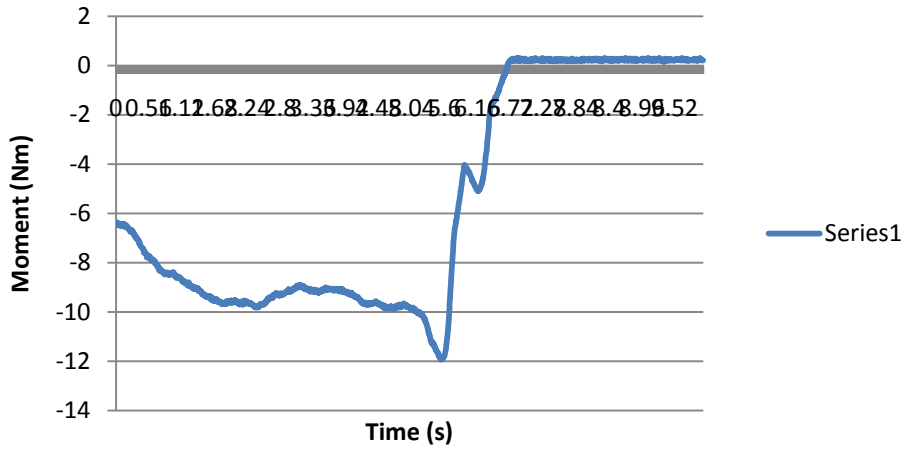

Alt 1 Circ CW Average Mz

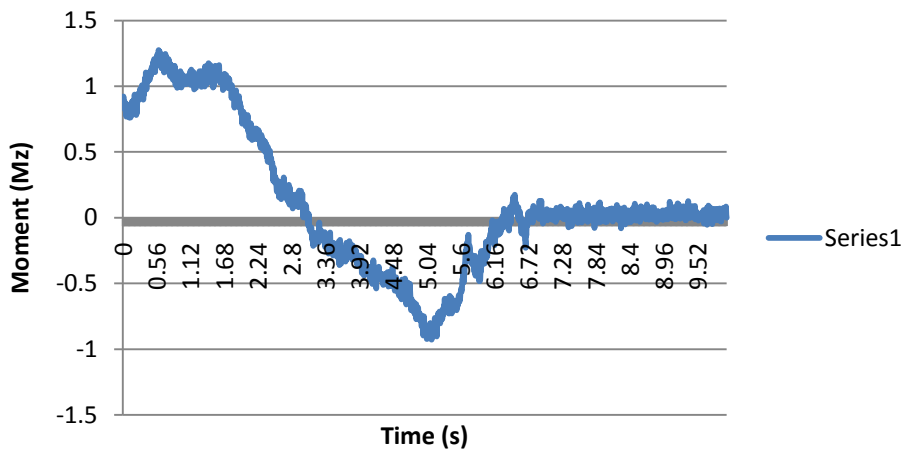

Alt 1 Elp CCW Fx

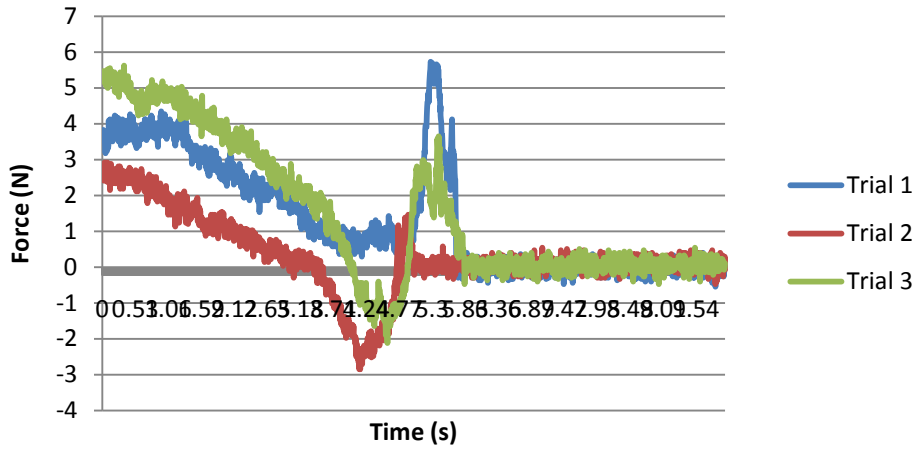

Alt 1 Elp CCW Fy

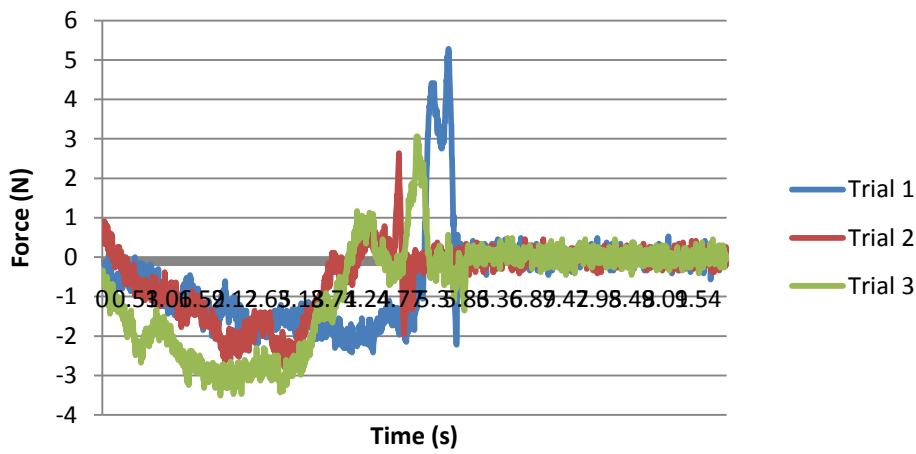

Alt 1 Elp CCW Fz

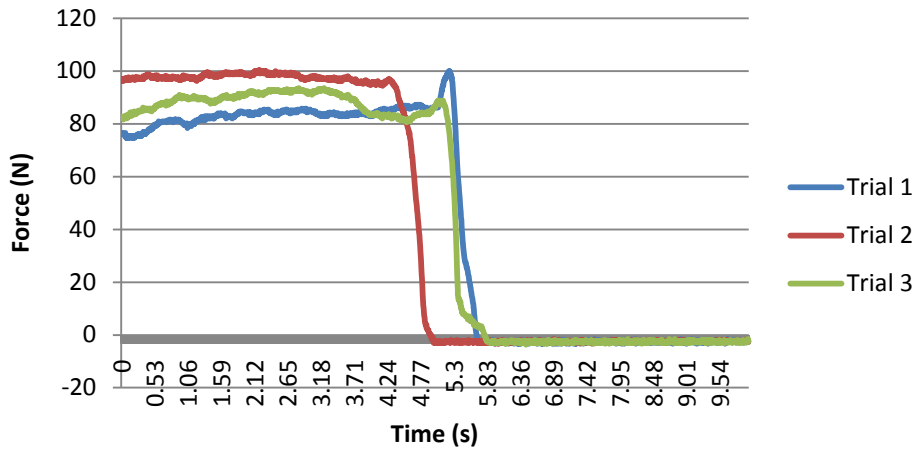

Alt 1 Elp CCW Mx

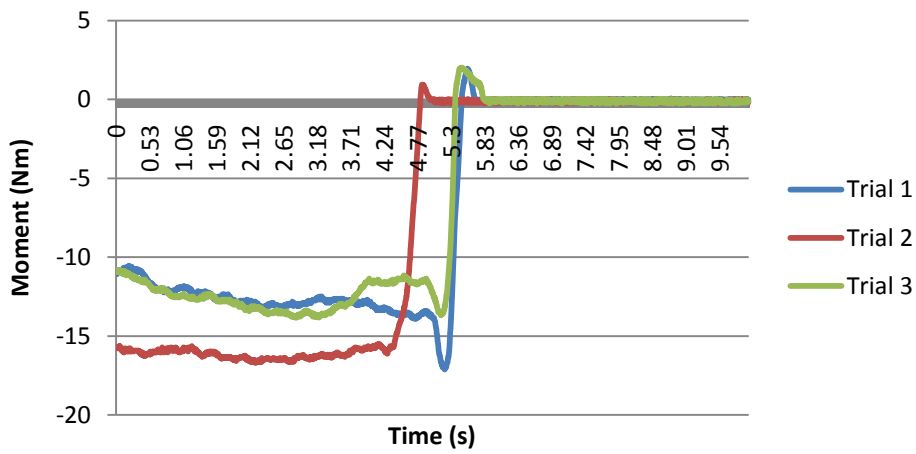

Alt 1 Elp CCW My

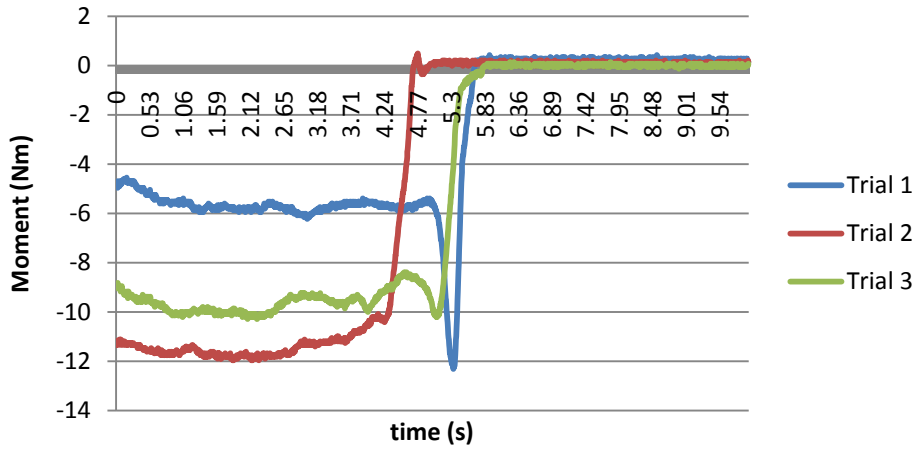

Alt 1 Elp CCW Mz

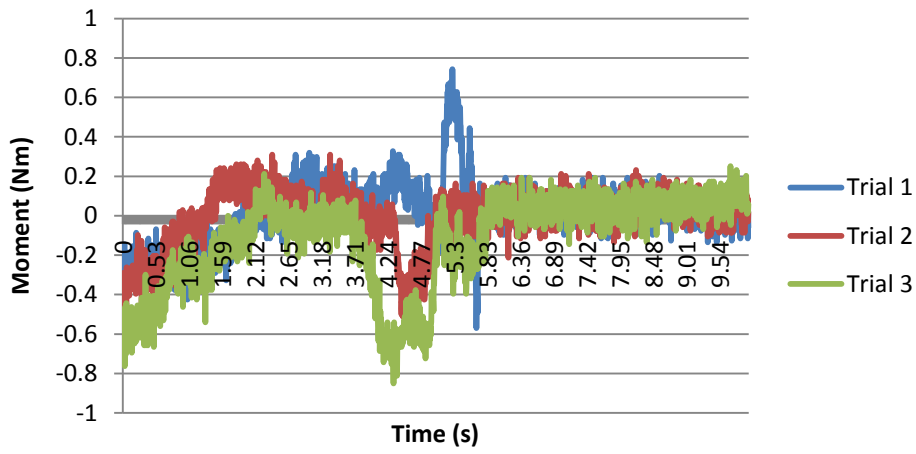

Alt 1 Elp CCW Average Fx

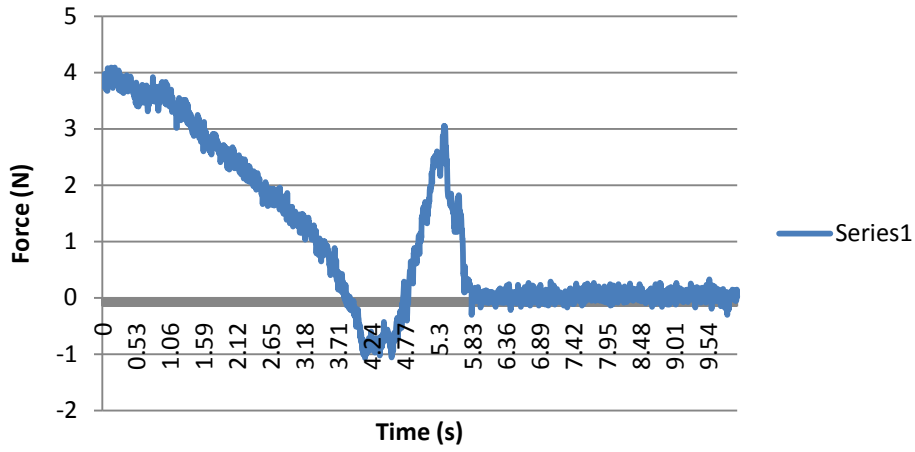

Alt 1 Elp CCW Average Fy

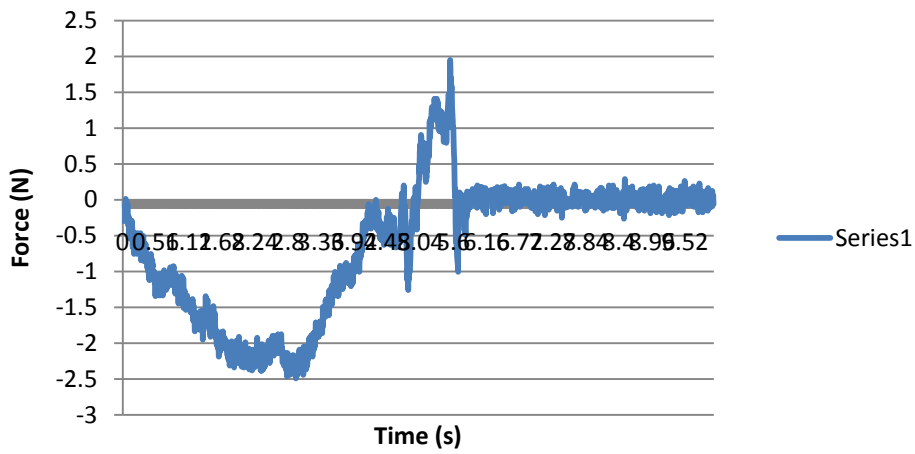

Alt 1 Elp CCW Average Fz

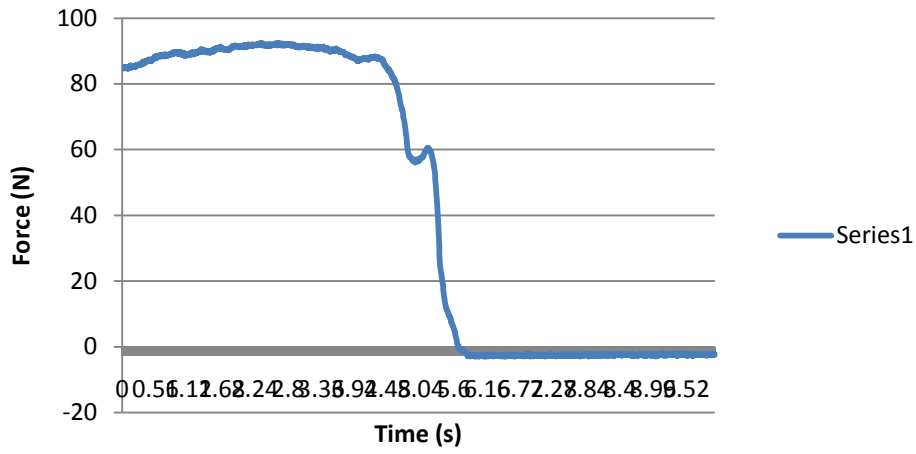

Alt 1 Elp CCW Average Mx

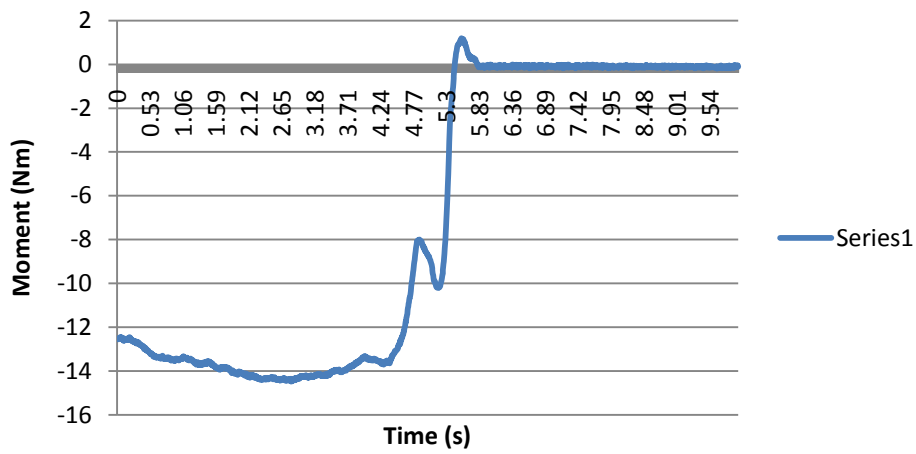

Alt 1 Elp CCW Average My

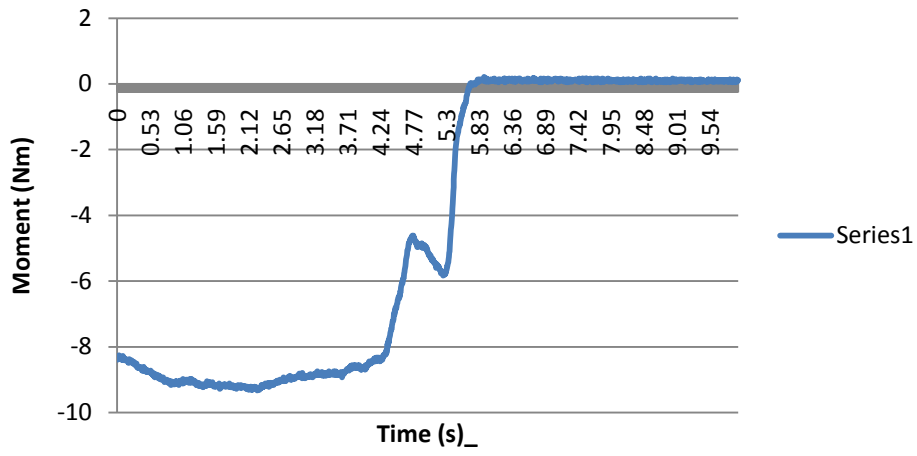

Alt 1 Elp CCW Average Mz

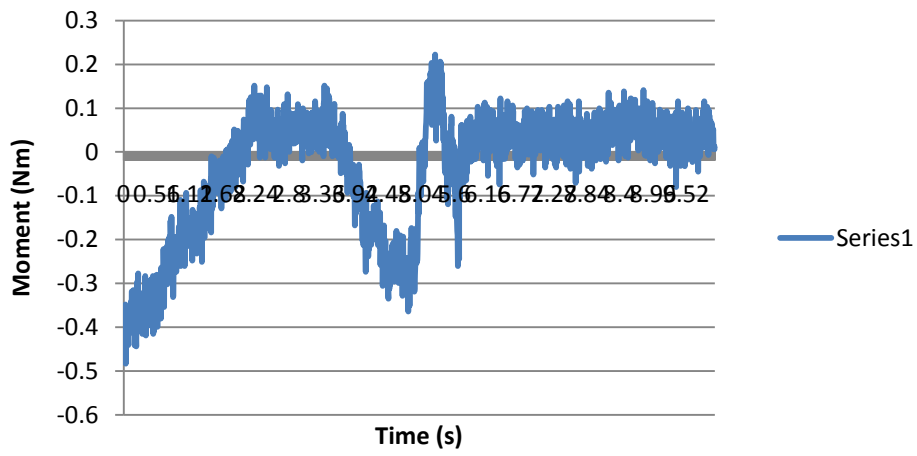

Alt 1 Elp CW Fx

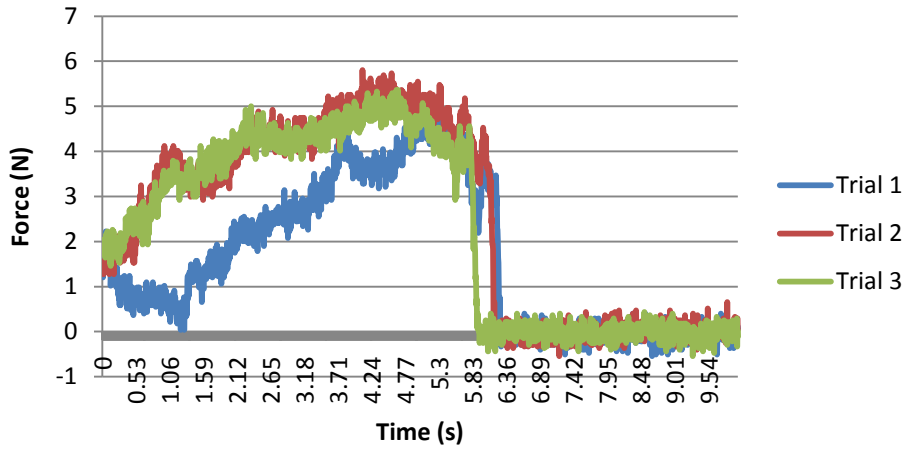

Alt 1 Elp CW Fy

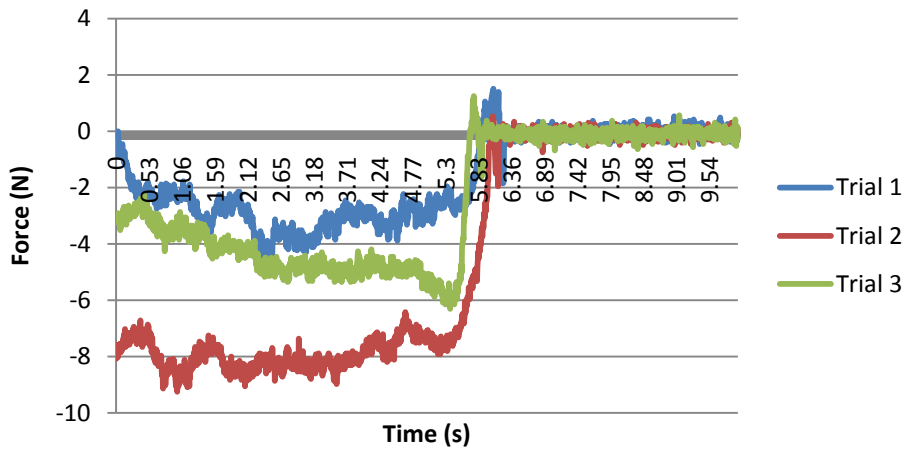

Alt 1 Elp CW Fz

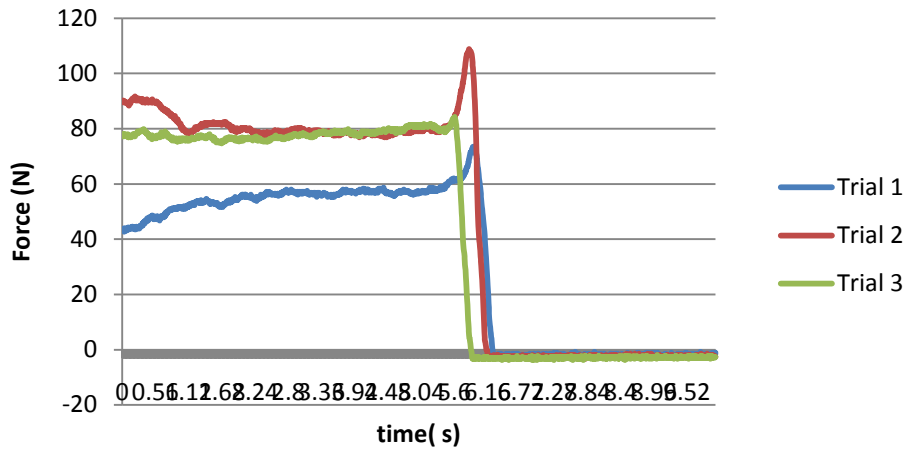

Alt 1 Elp CW Mx

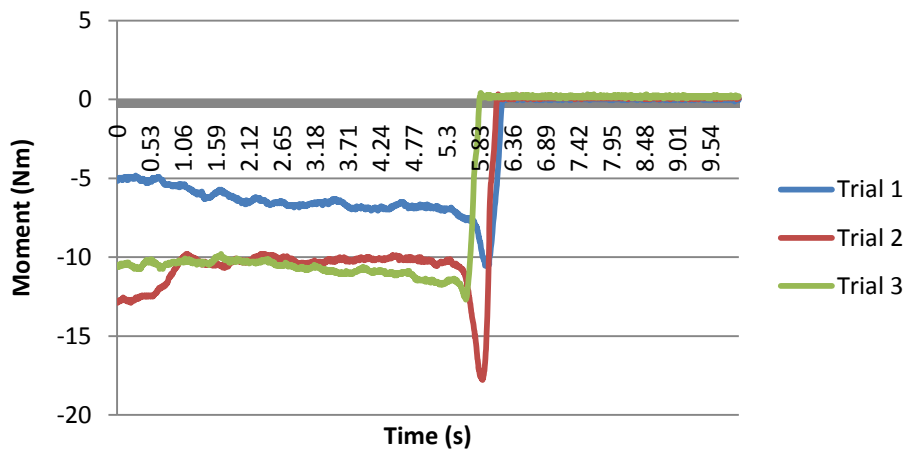

Alt 1 Elp CW My

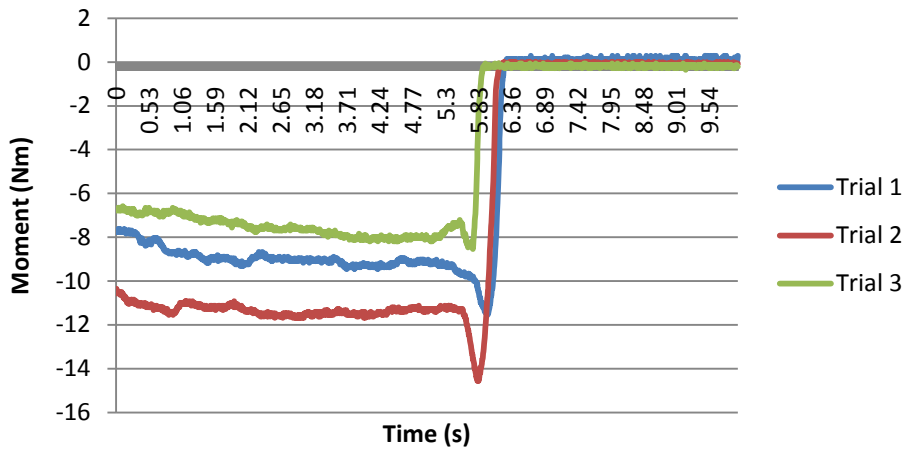

Alt 1 Elp CW Mz

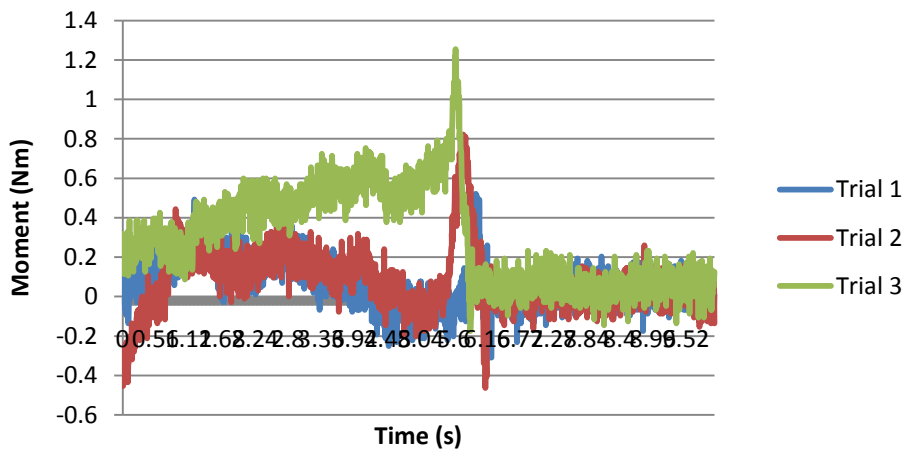

Alt 1 Elp CW Average Fx

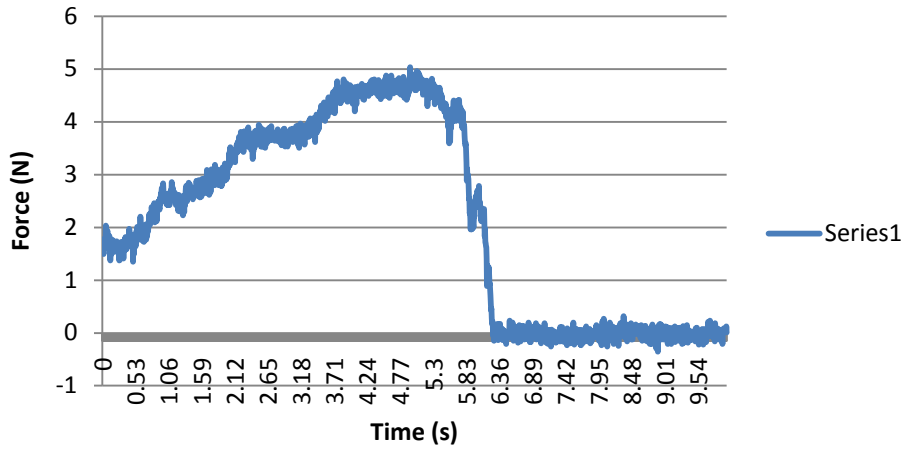

Alt 1 Elp CW Average Fy

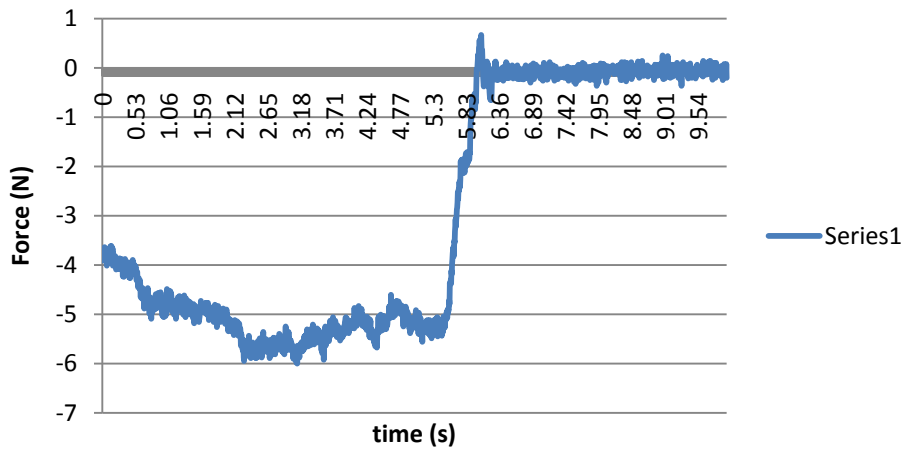

Alt 1 Elp CW Average Fz

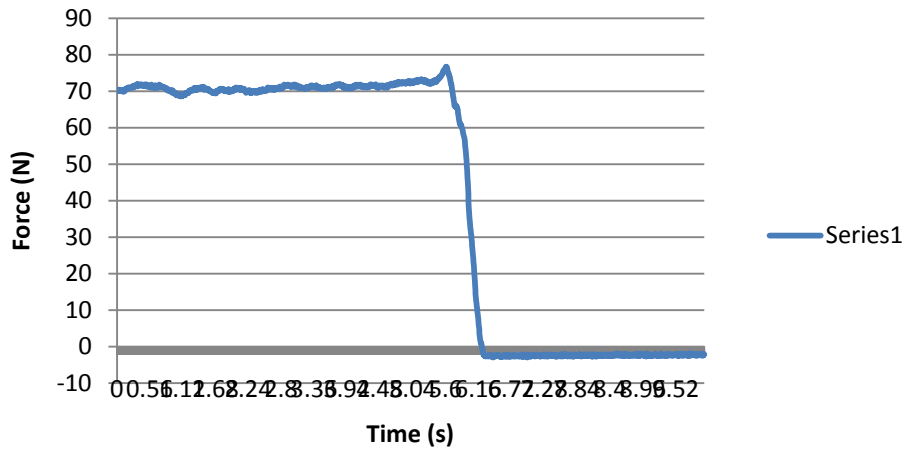

Alt 1 Elp CW Average Mx

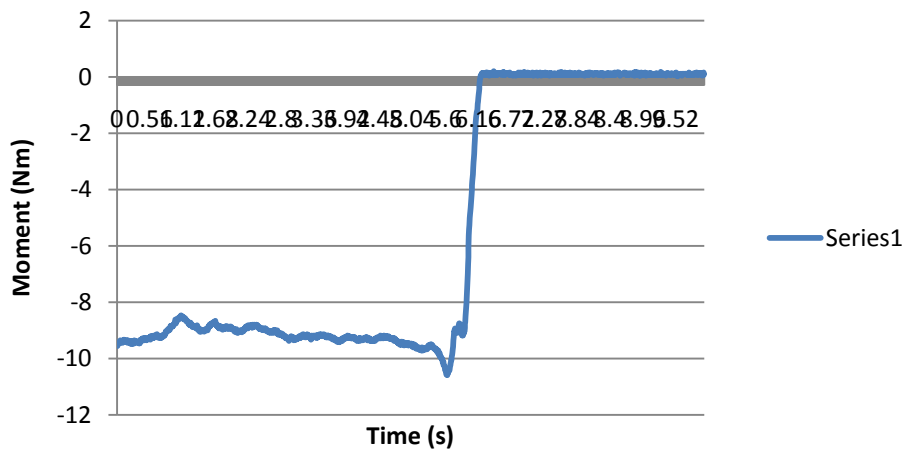

Alt 1 Elp CW Average My

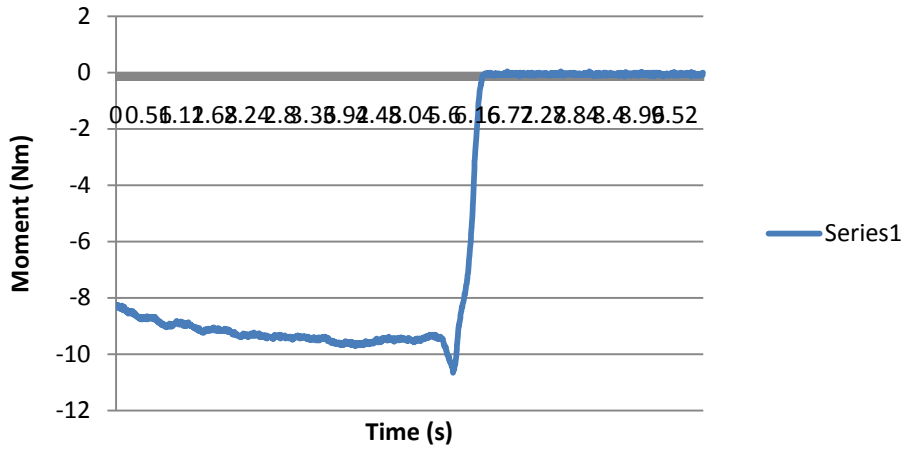

Alt 1 Elp CW Average Mz

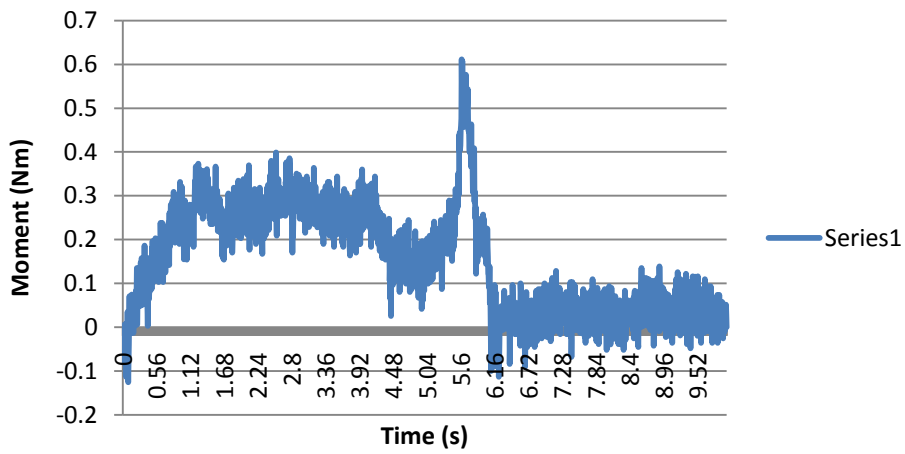

Alt 1 Horz Linear Fx

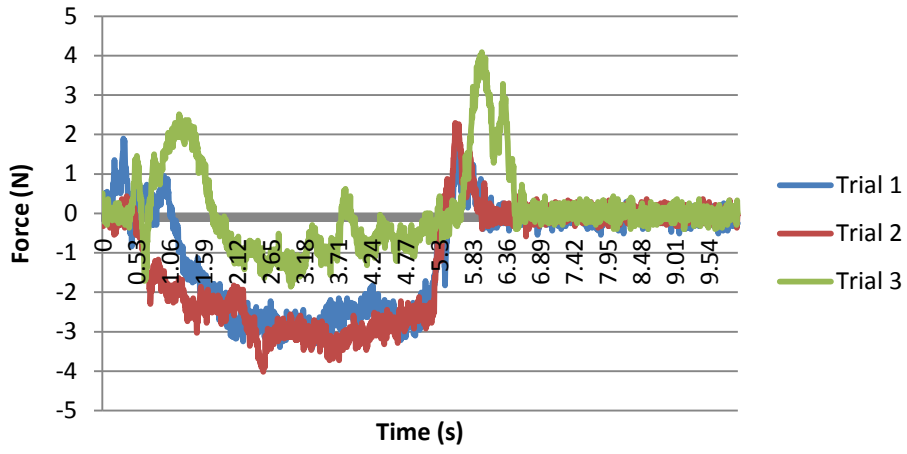

Alt 1 Horz Linear Fy

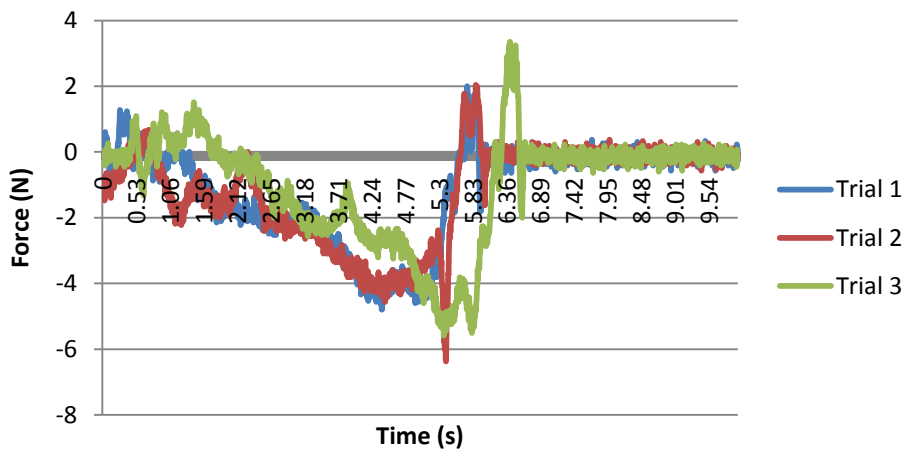

Alt 1 Horz Linear Fz

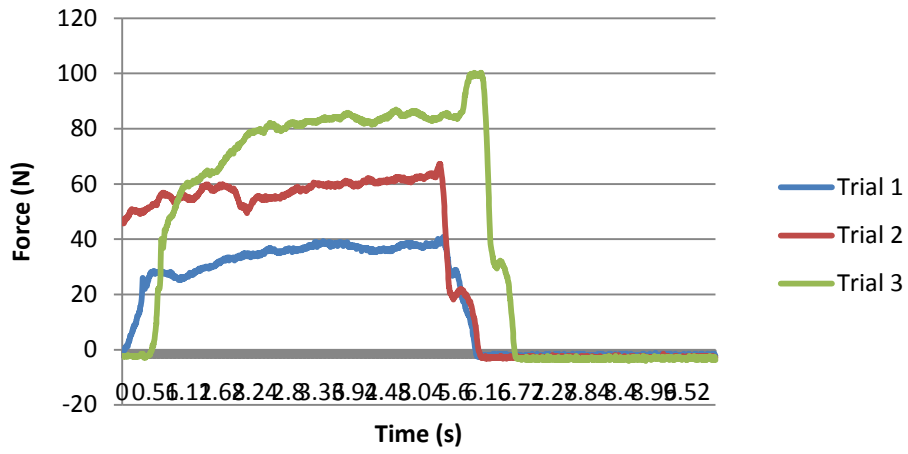

Alt 1 Horz Linear Mx

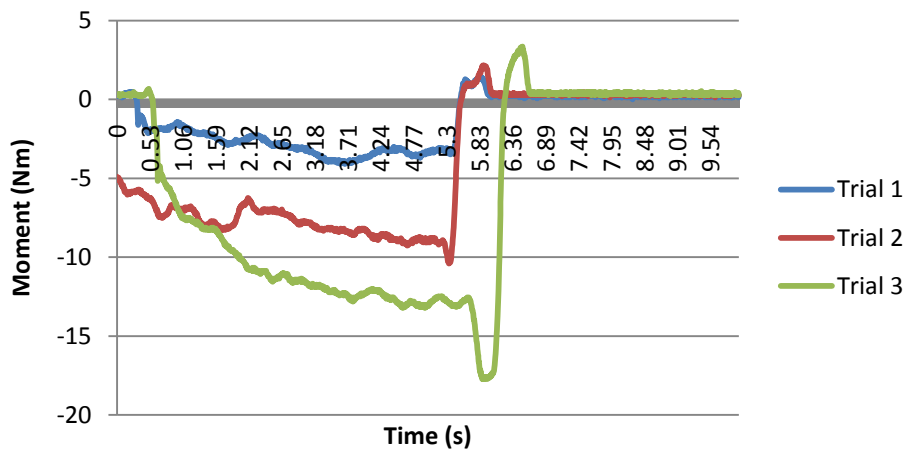

Alt 1 Horz Linear My

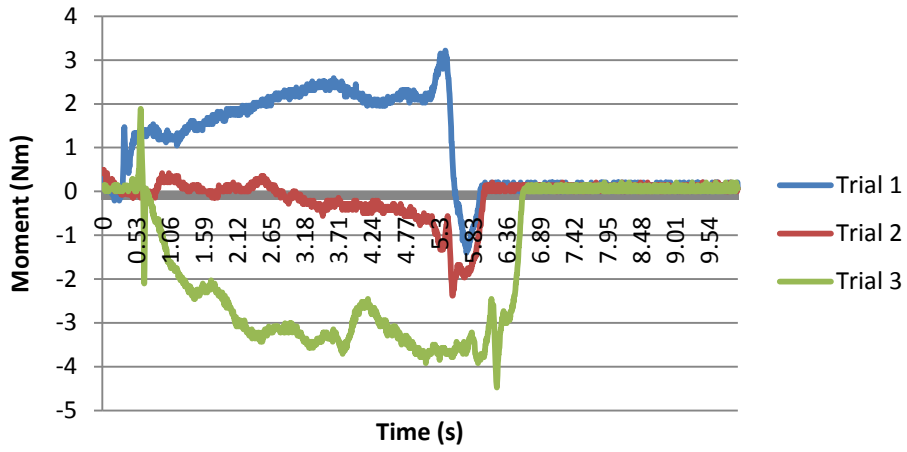

Alt 1 Horz Linear Mz

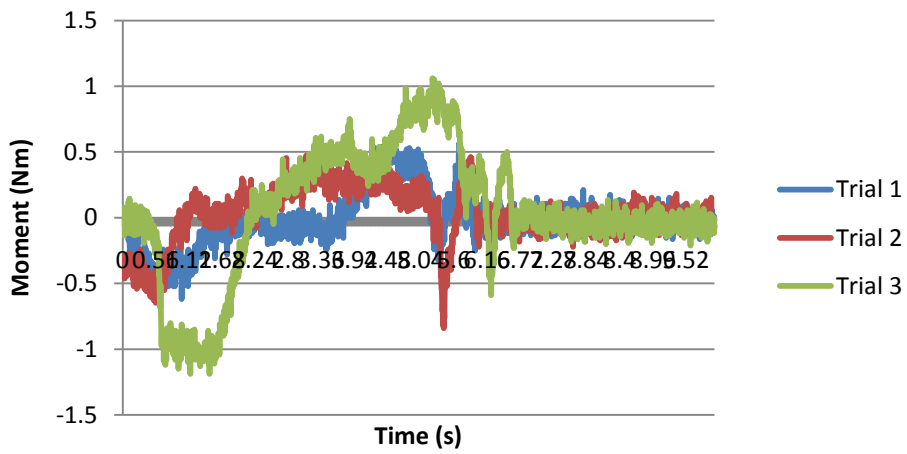

Alt 1 Horz Linear average Fx

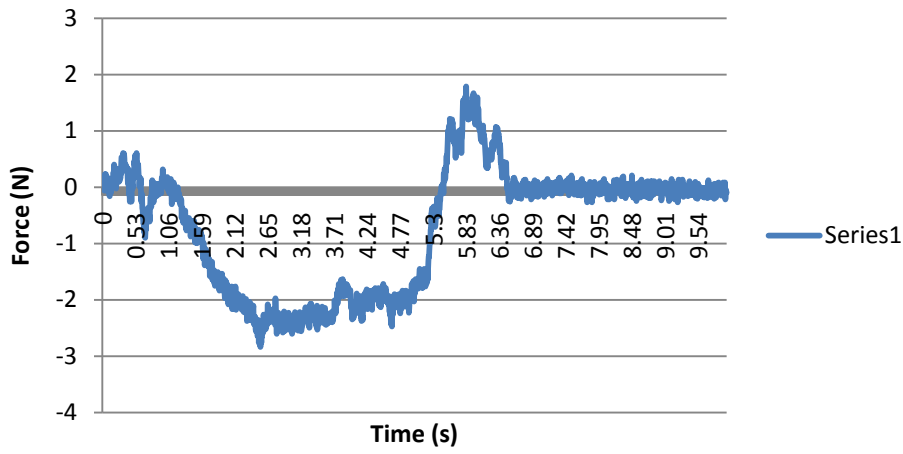

Alt 1 Horz Linear Average Fy

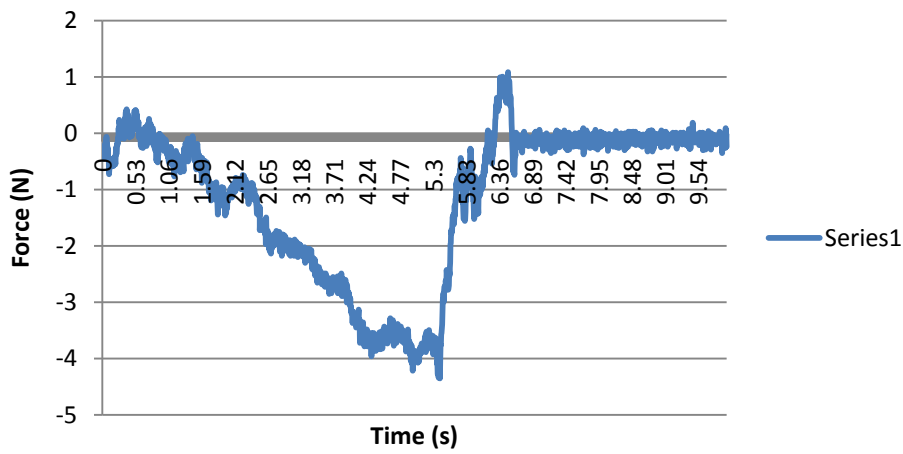

Alt 1 Horz Linear Average Fz

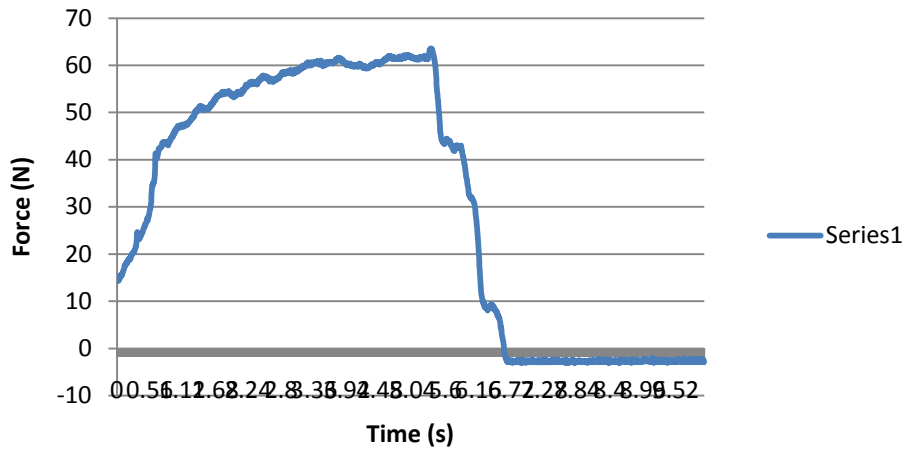

Alt 1 Horz Linear Average Mx

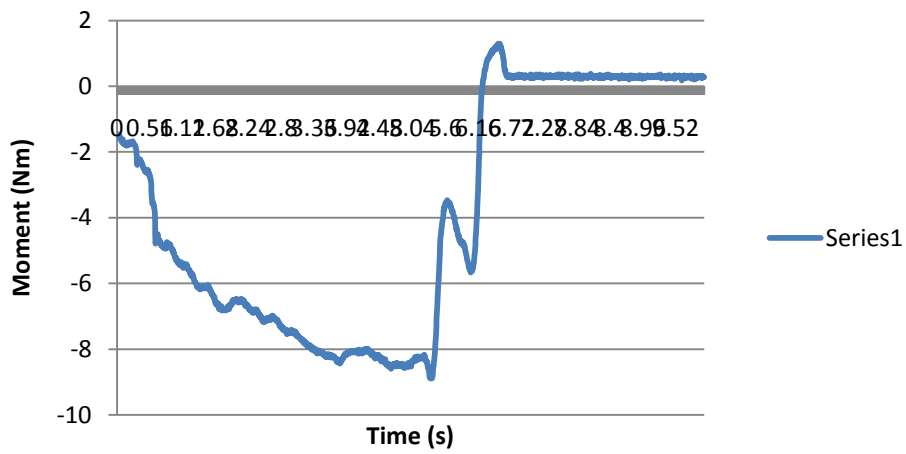

Alt 1 Horz Linear Average My

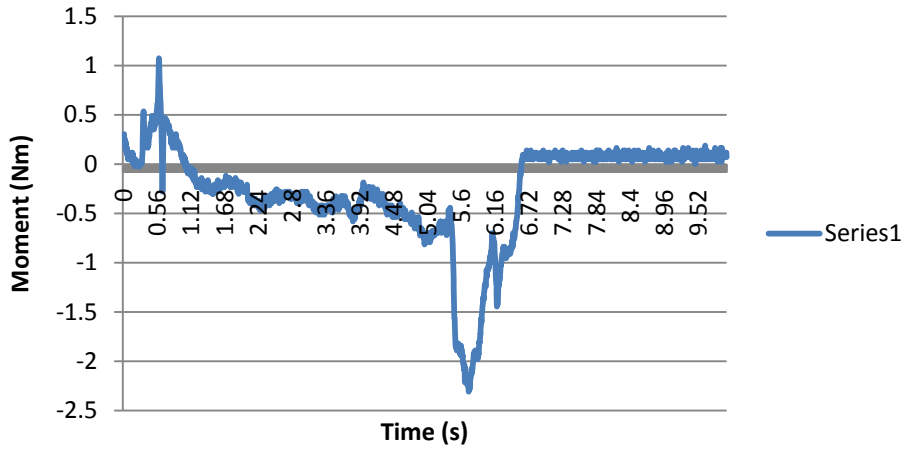

Alt 1 Horz Linear Average Mz

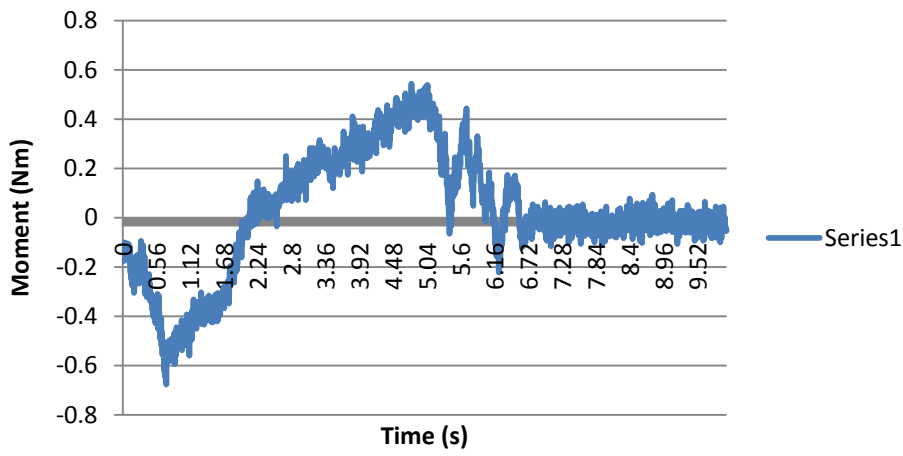

Alt 1 Vert Linear Fx

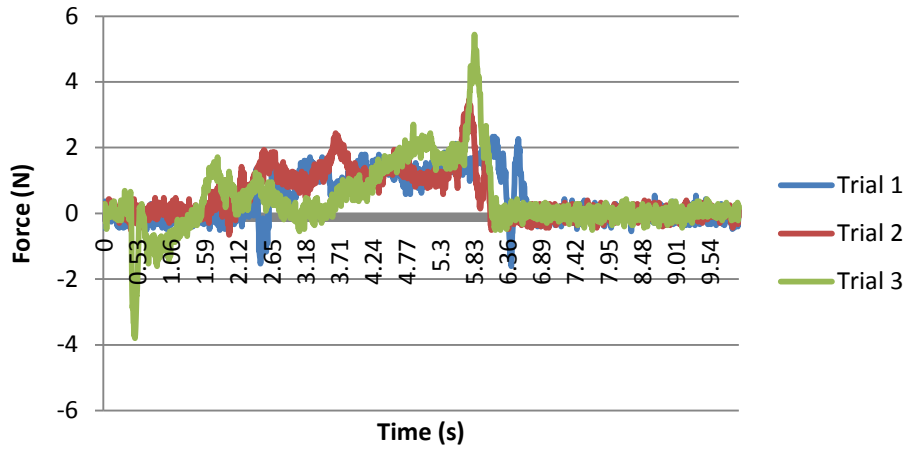

Alt 1 Vert Linear Fy

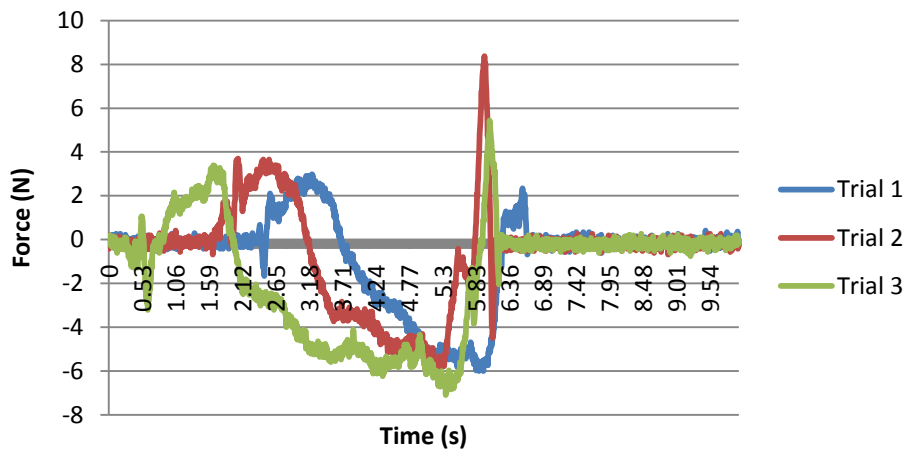

Alt 1 Vert Linear Fz

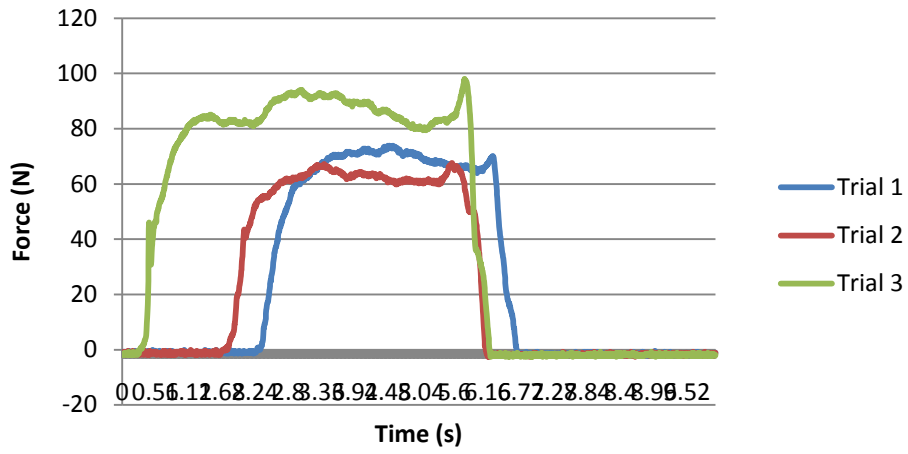

Alt 1 Vert Linear Mx

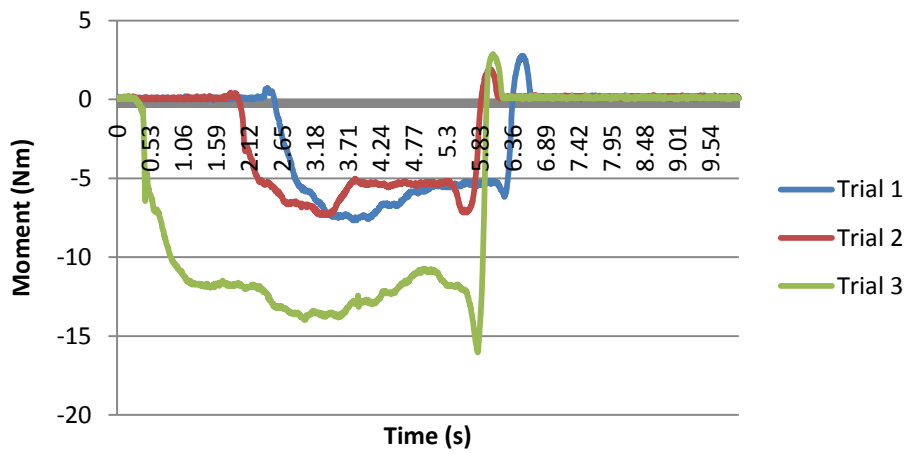

Alt 1 Vert Linear My

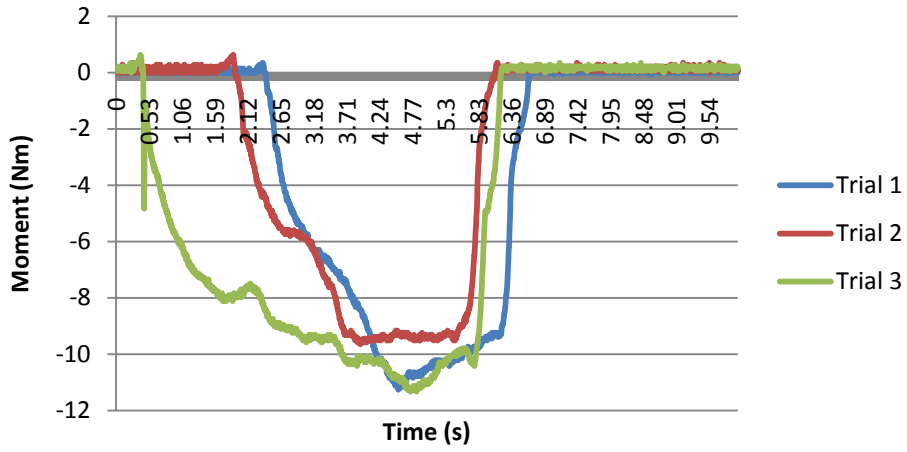

Alt 1 Vert Linear Mz

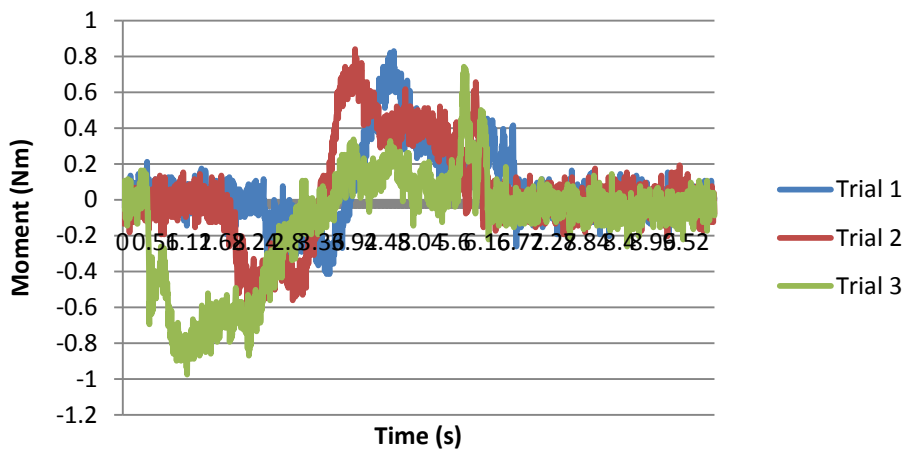

Alt 1 Vert Linear Average Fx

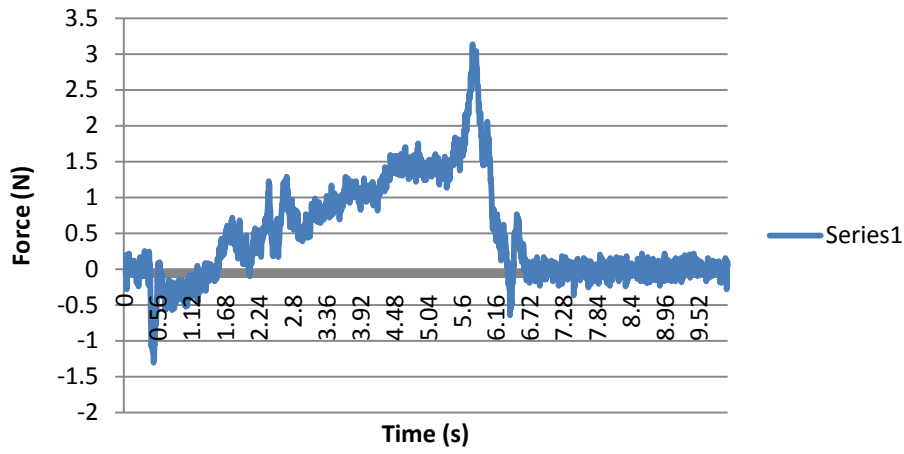

Alt 1 Vert Linear Average Fy

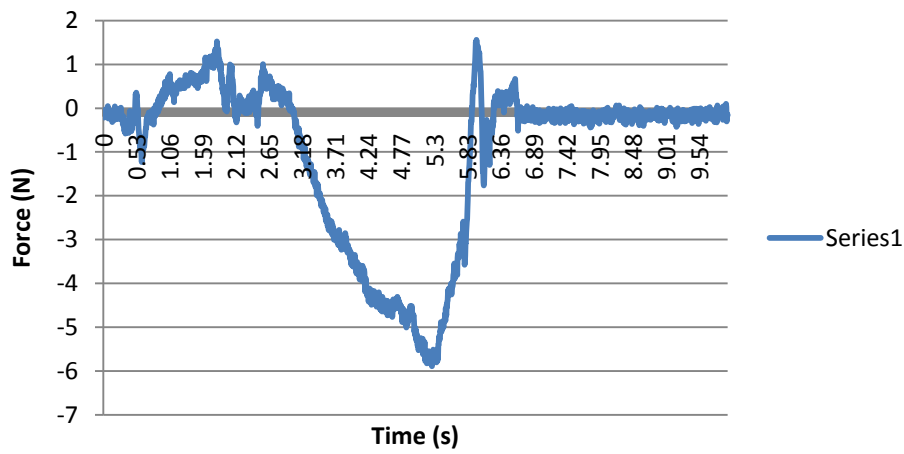

Alt 1 Vert Linear Average Fz

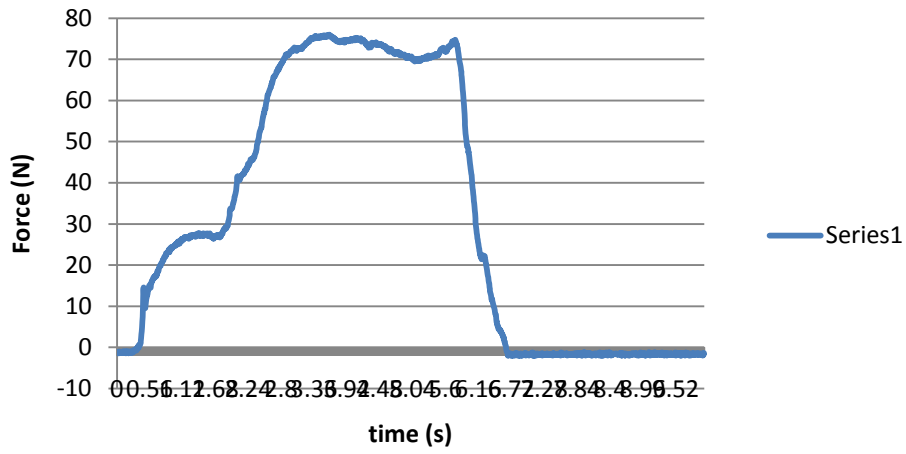

Alt 1 Vert Linear Average Mx

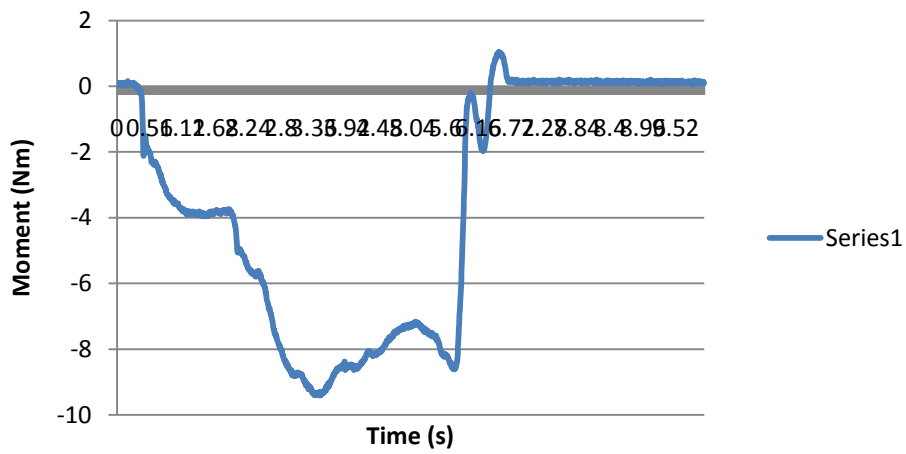

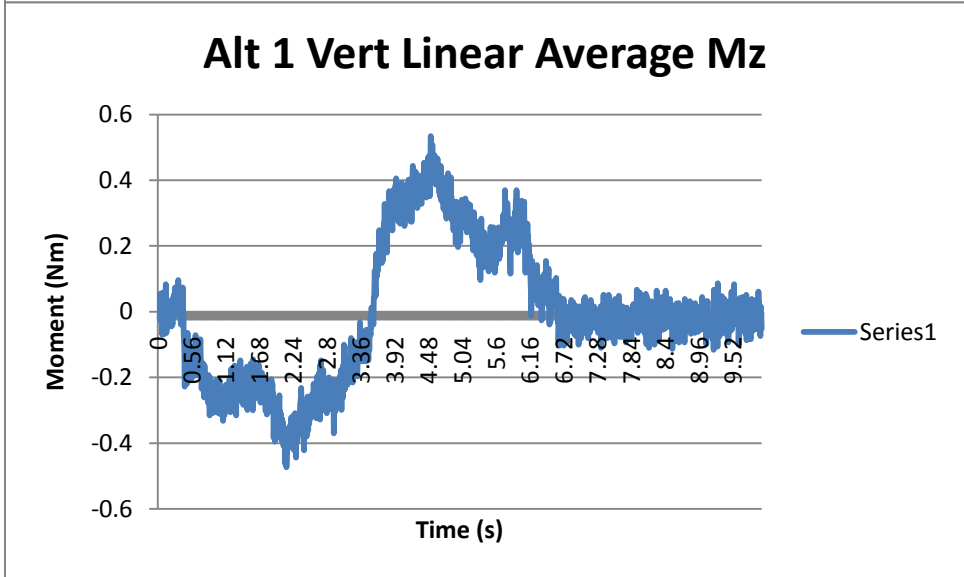
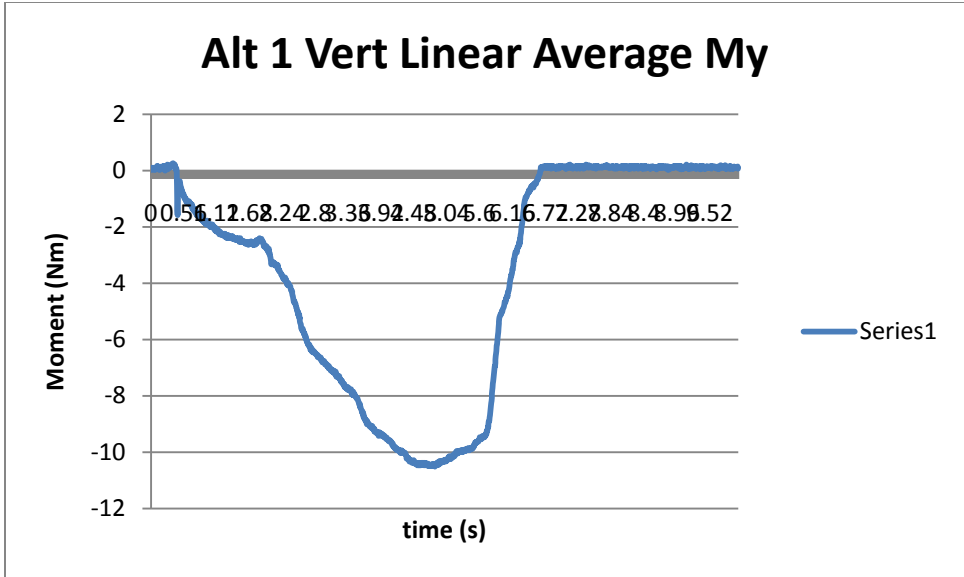

Alternative 2

Alt 2 Circ CCW Fx

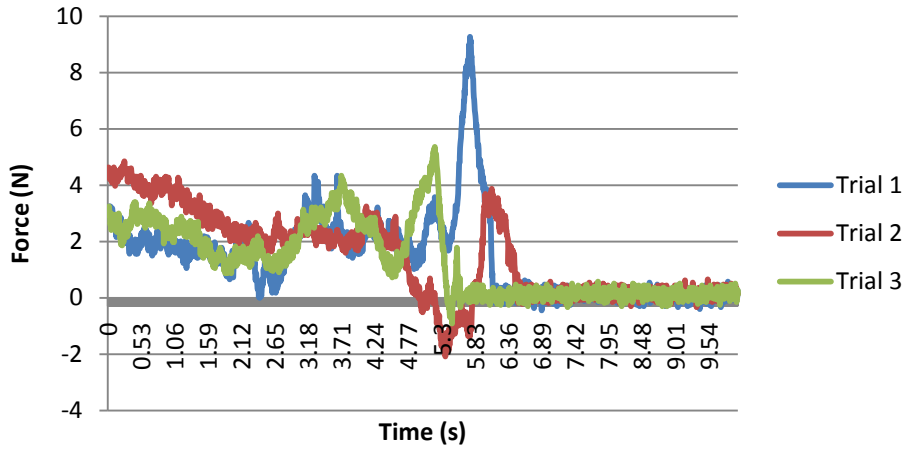

Alt 2 Circ CCW Fy

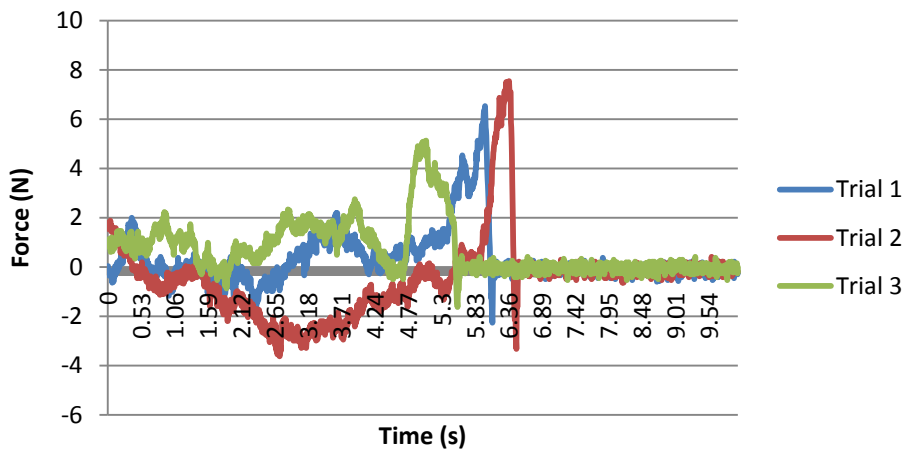

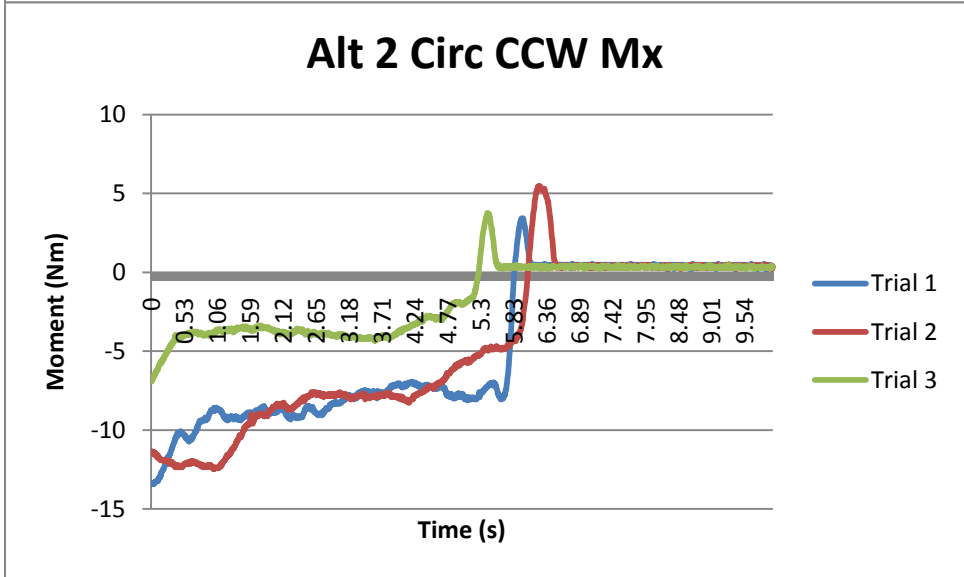
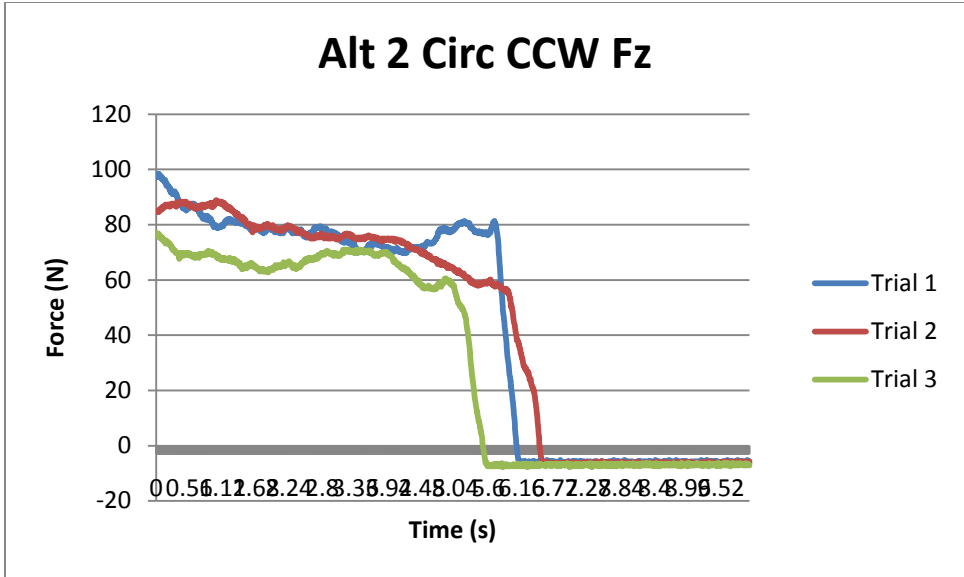

Alt 2 Circ CCW My

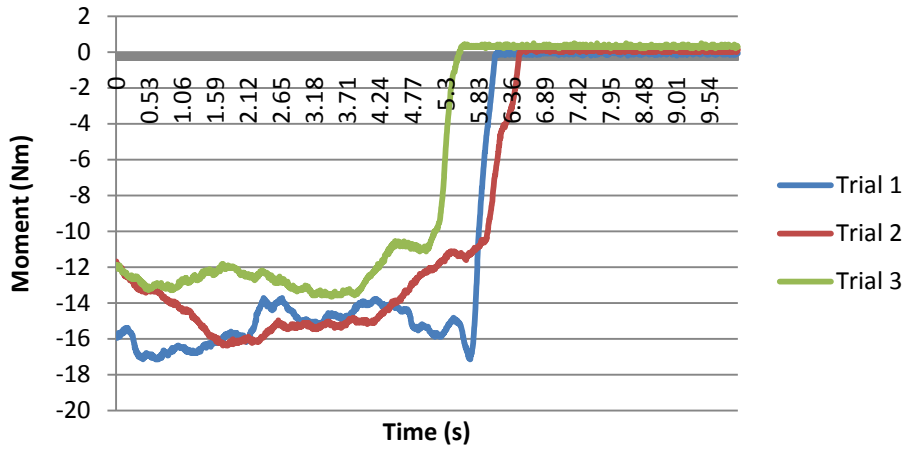

Alt 2 Circ CCW Mz

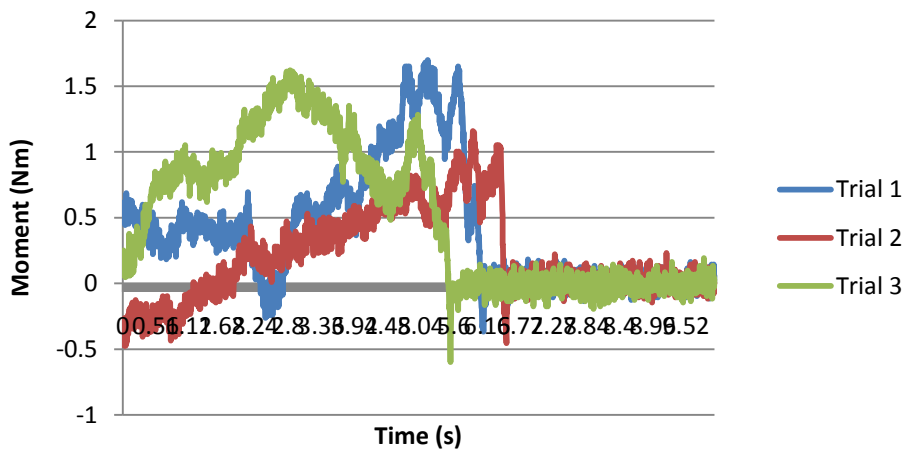

Alt 2 Circ CCW Average Fx

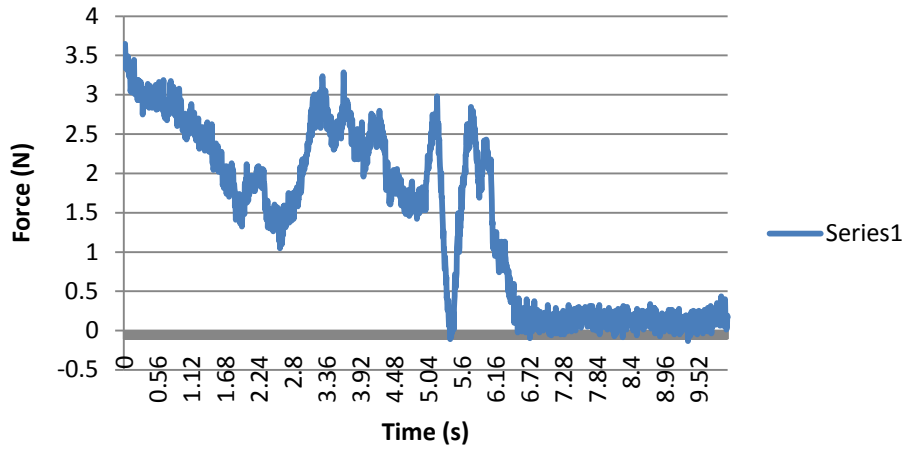

Alt 2 Circ CCW Average Fy

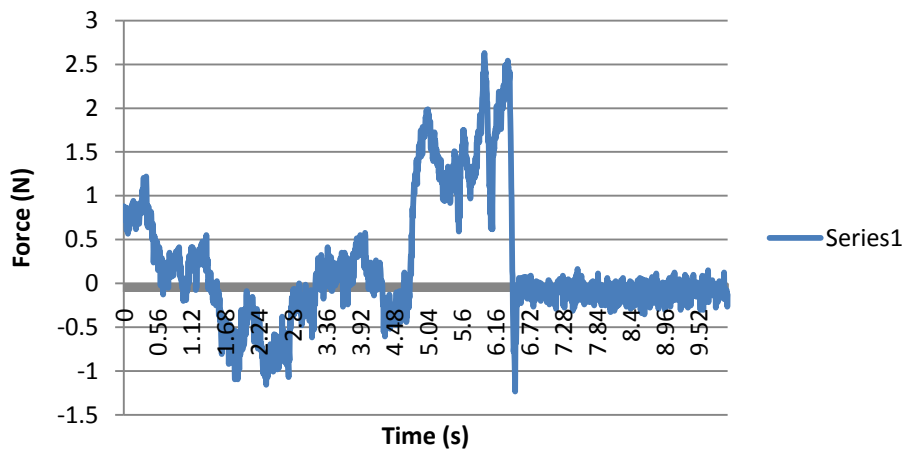

Alt 2 Circ CCW Average Fz

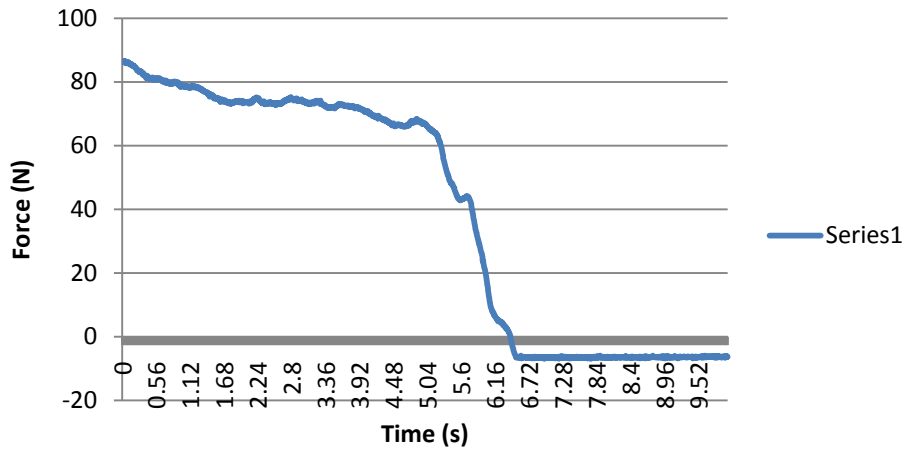

Alt 2 Circ CCW Average Mx

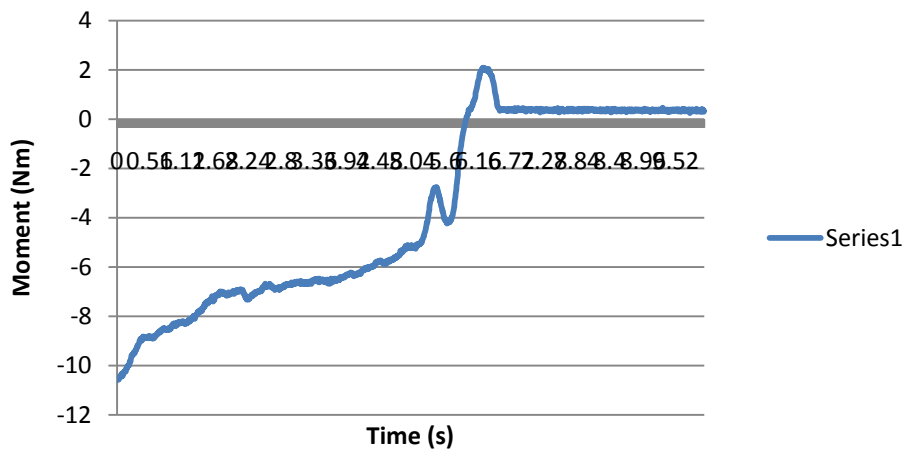

Alt 2 Circ CCW Average My

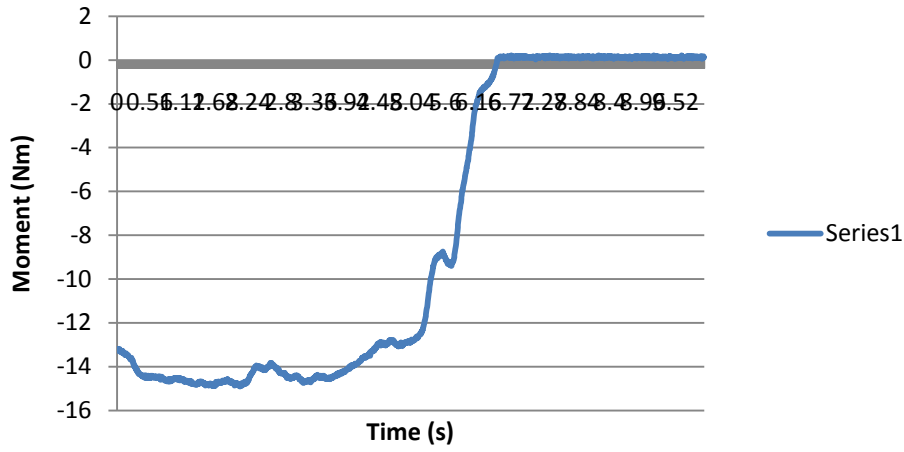

Alt 2 Circ CCW Average Mz

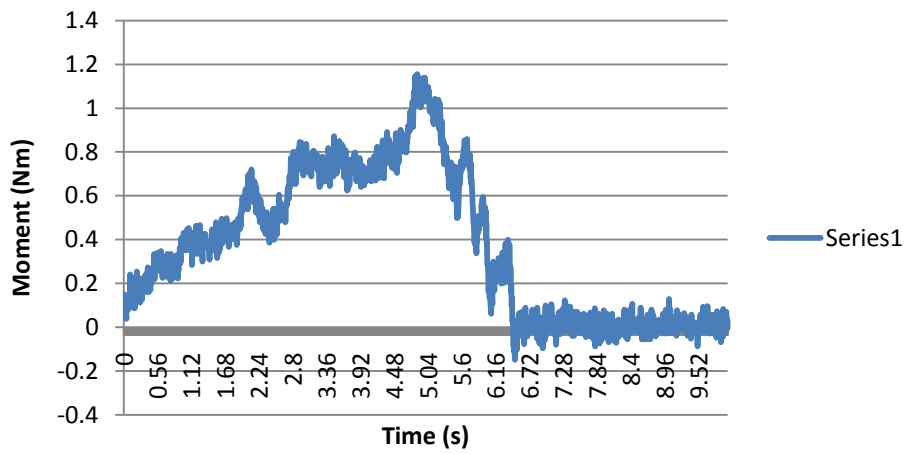

Alt 2 Circ CW Fx

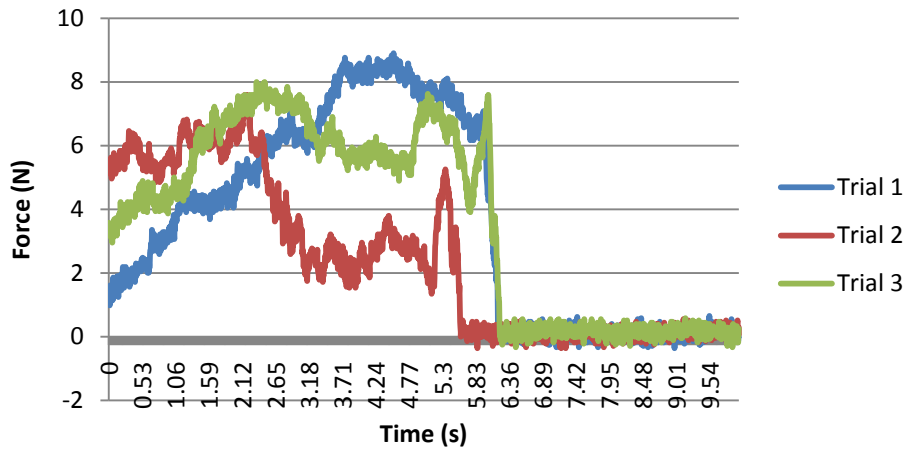

Alt 2 Circ CW Fy

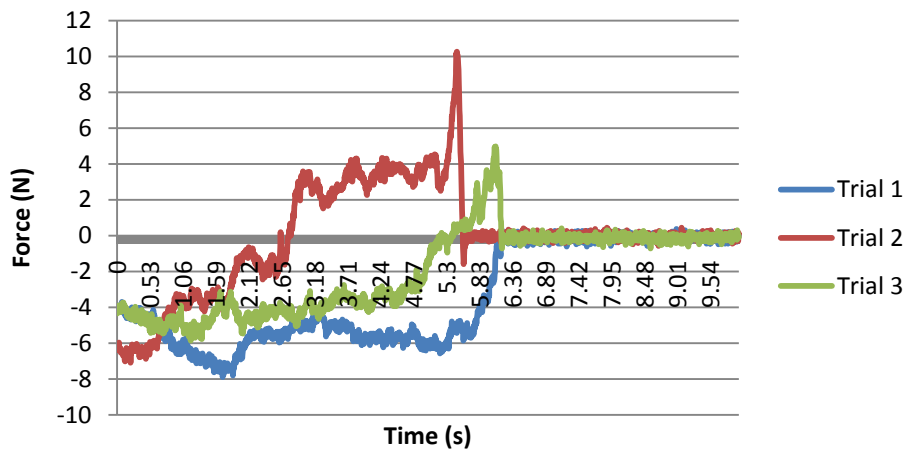

Alt 2 Circ CW Fz

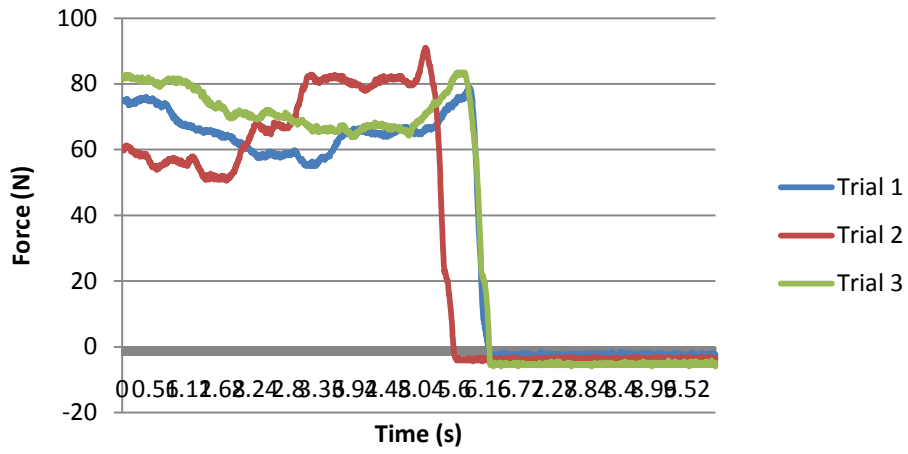

Alt 2 Circ CW Mx

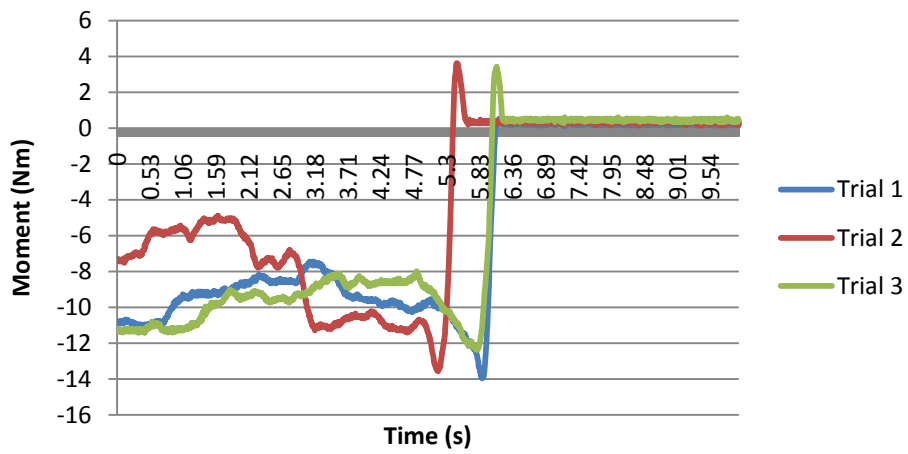

Alt 2 Circ CW My

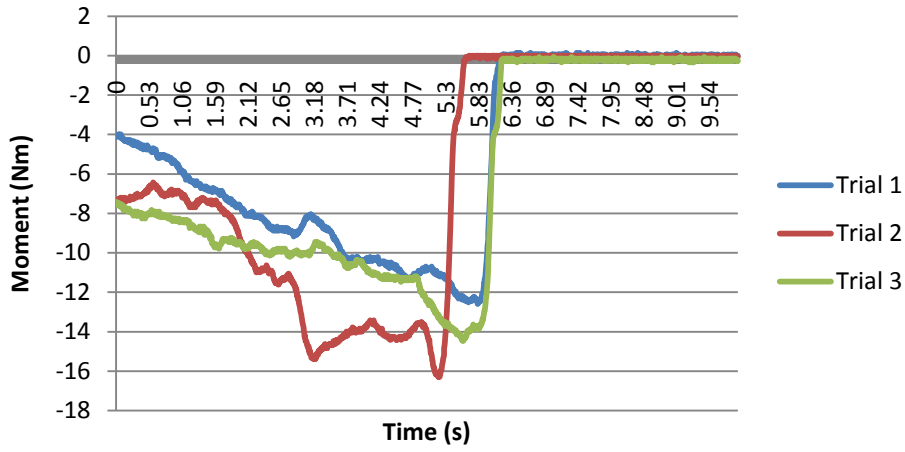

Alt 2 Circ CW Mz

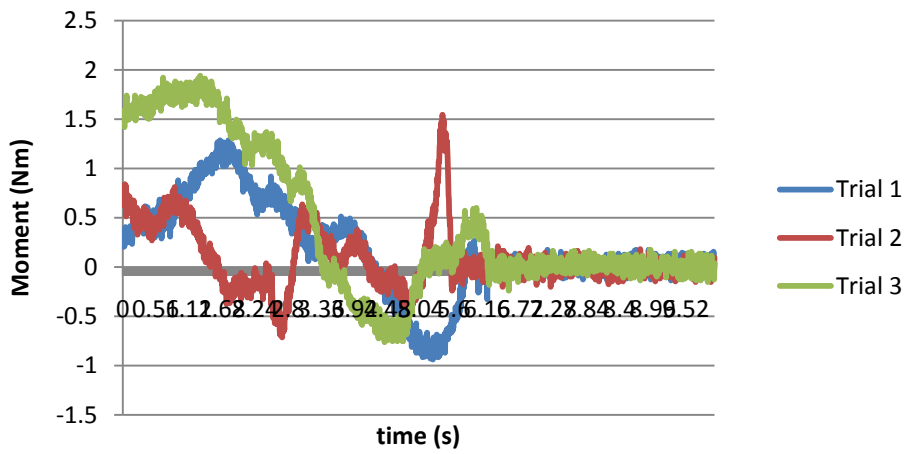

Alt 2 Circ CW Average Fx

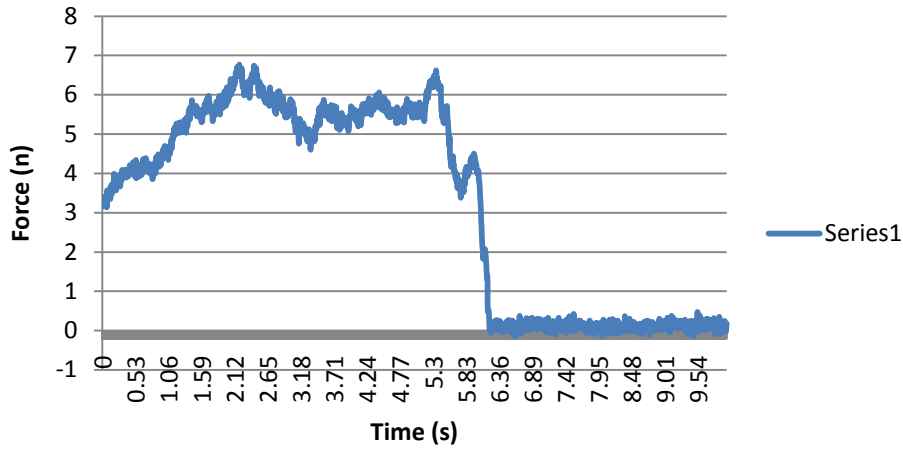

Alt 2 Circ CW Average Fy

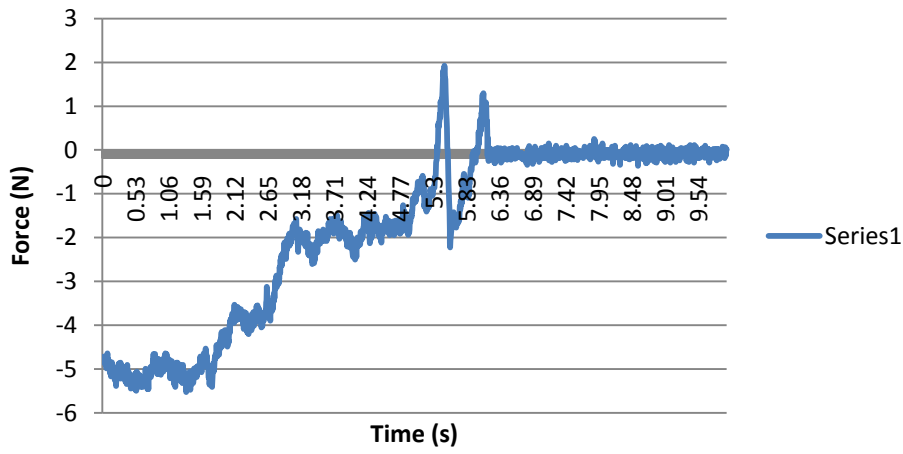

Alt 2 Circ CW Average Fz

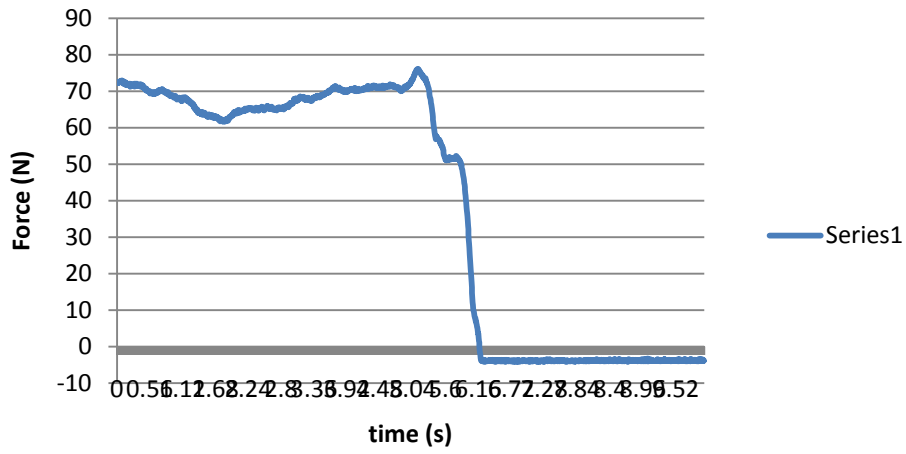

Alt 2 Circ CW Average Mx

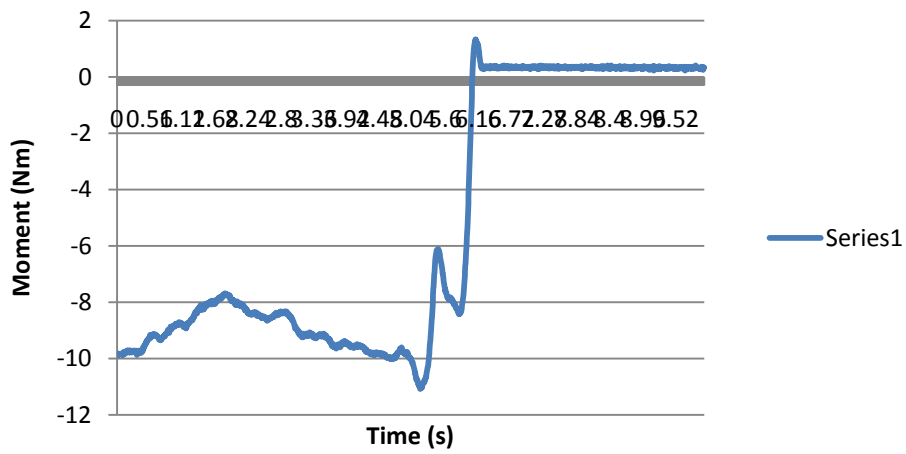

Alt 2 Circ CW Average My

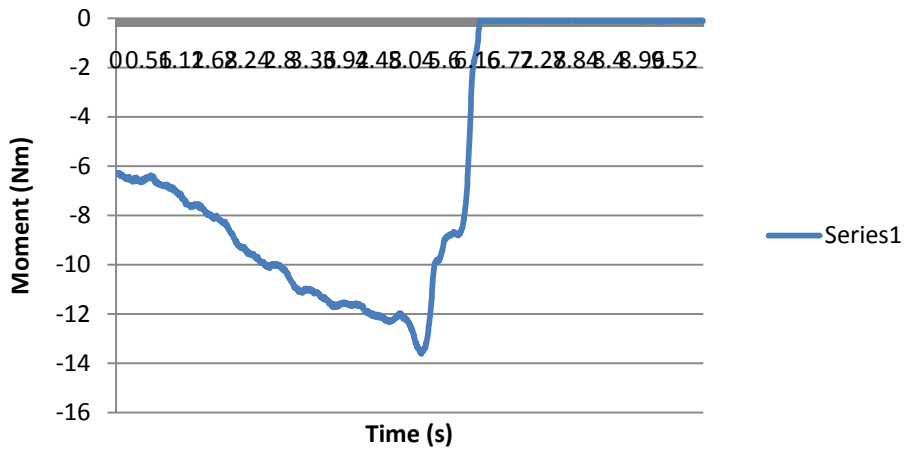

Alt 2 Circ CW Average Mz

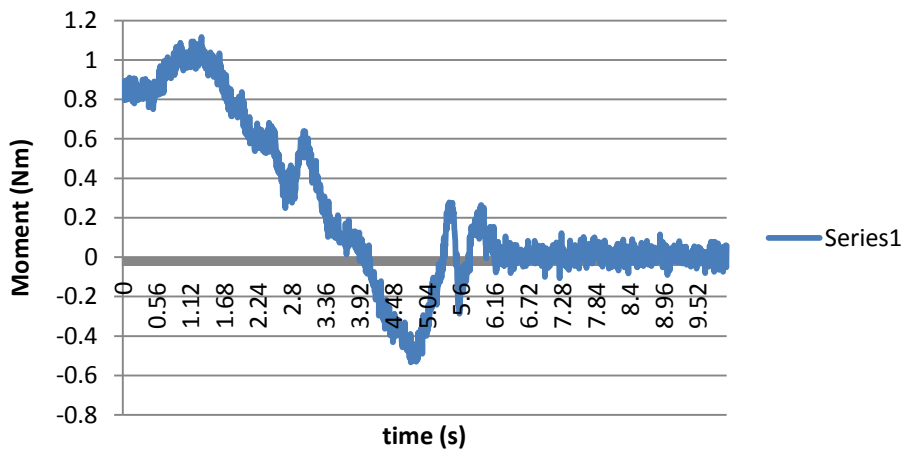

Alt 2 Elp CCW Fx

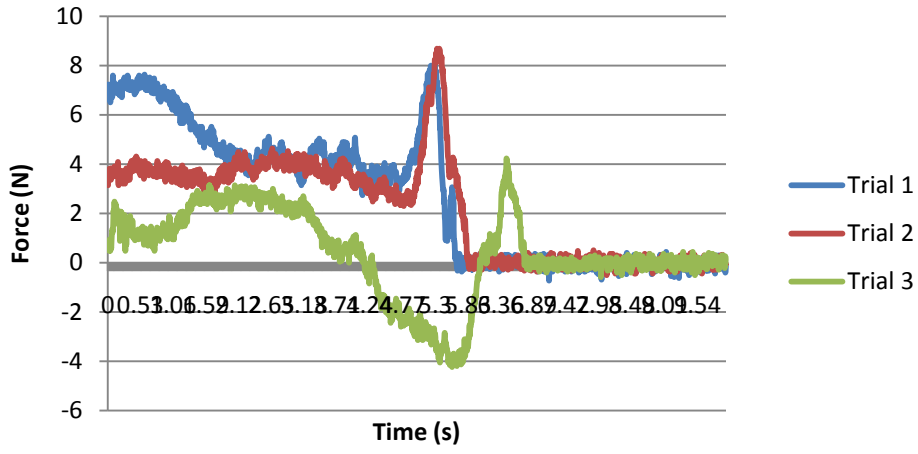

Alt 2 Elp CCW Fy

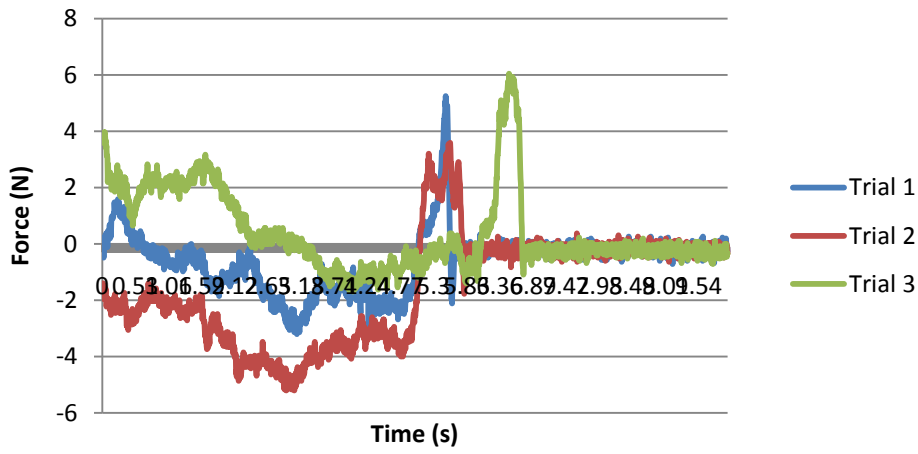

Alt 2 Elp CCW Fz

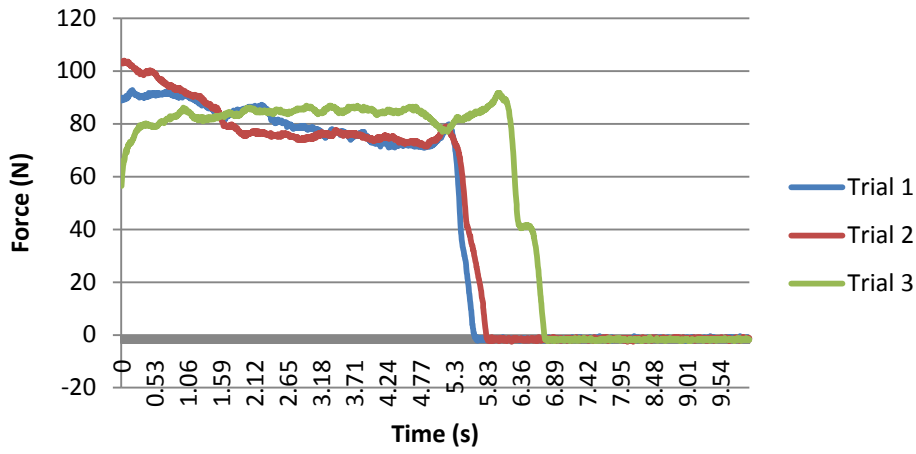

Alt 2 Elp CCW Mx

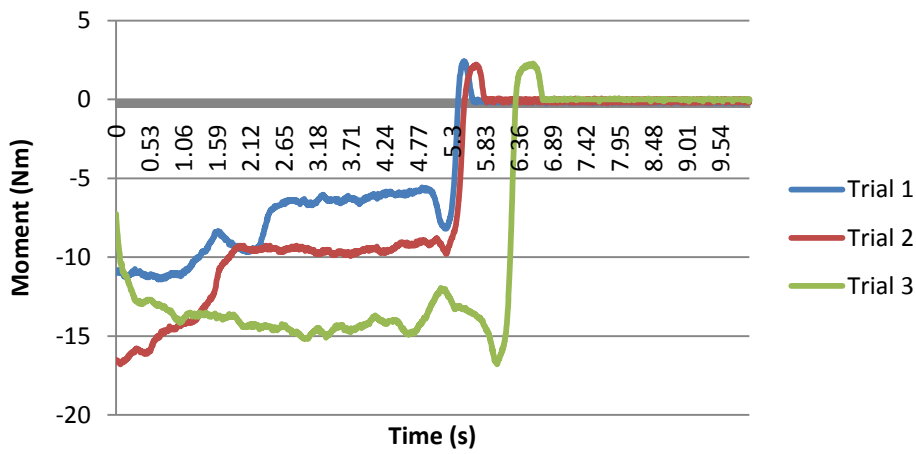

Alt 2 Elp CCW My

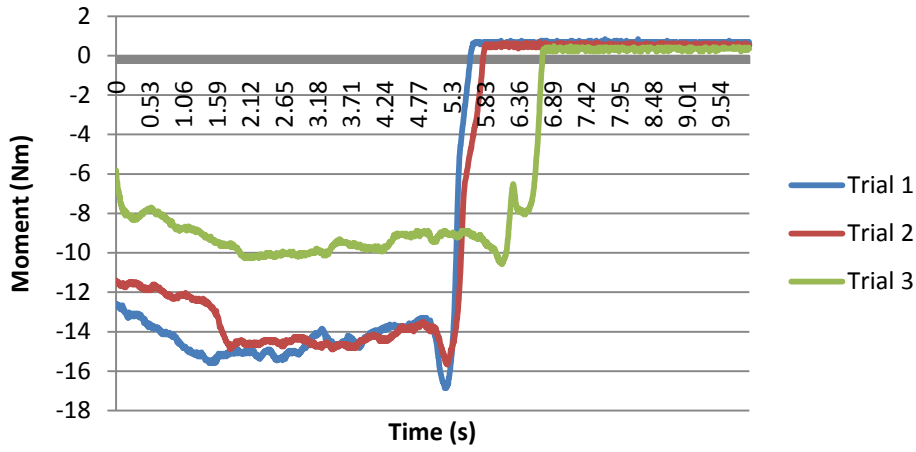

Alt 2 Elp CCW Mz

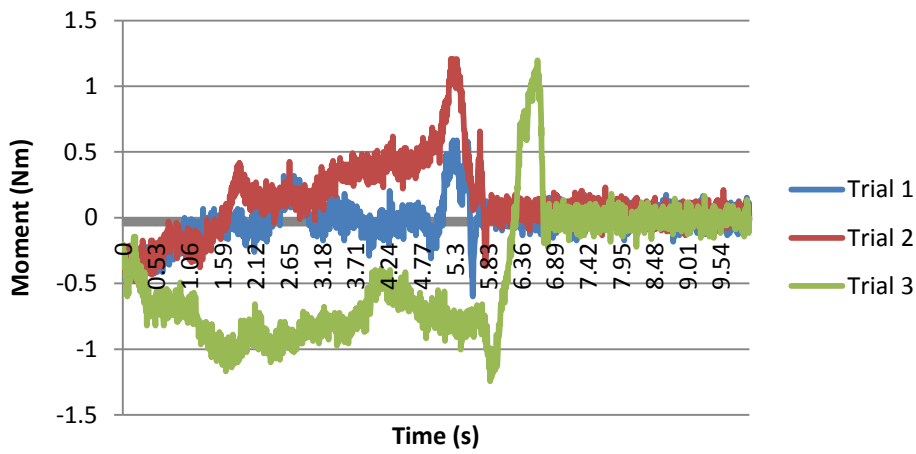

Alt 2 Elp CCW Average Fx

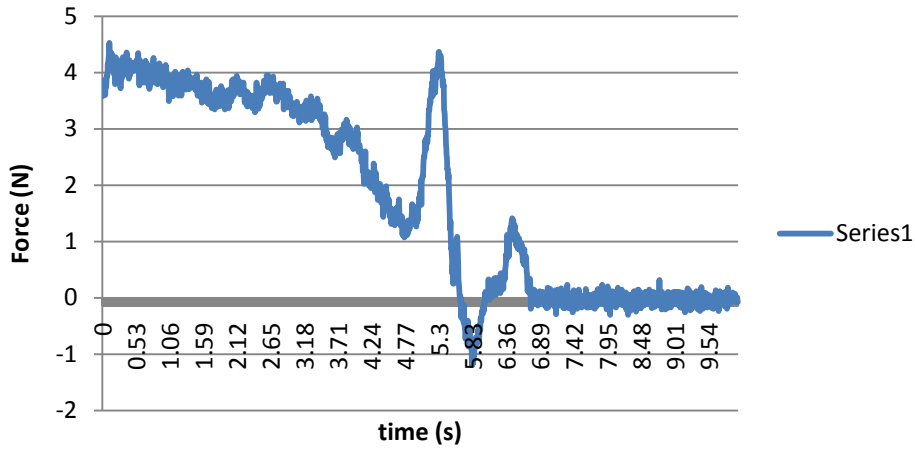

Alt 2 Elp CCW Average Fy

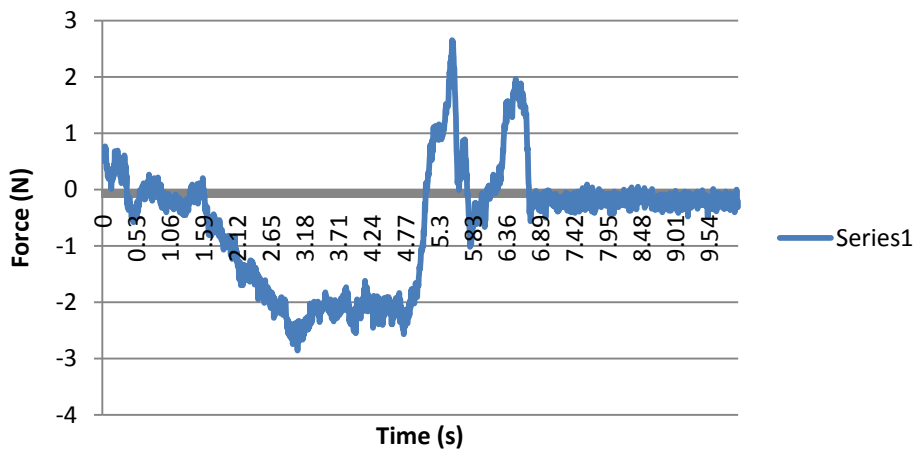

Alt 2 Elp CCW Average Fz

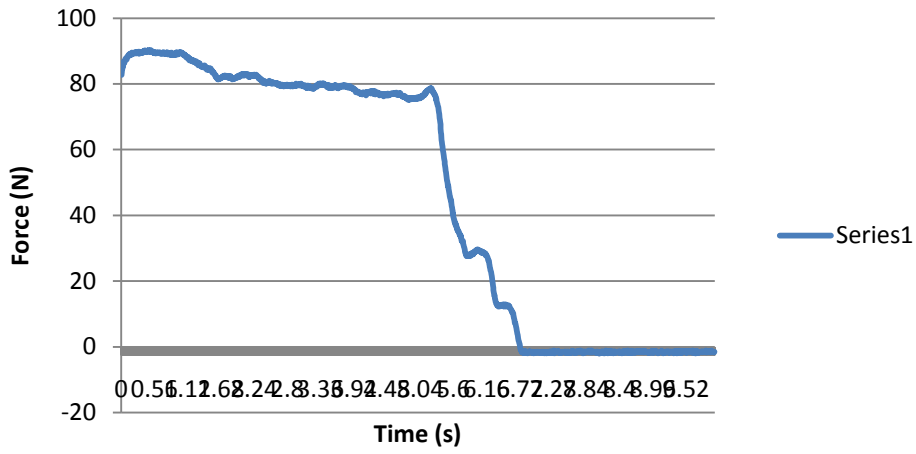

Alt 2 Elp CCW Average Mx

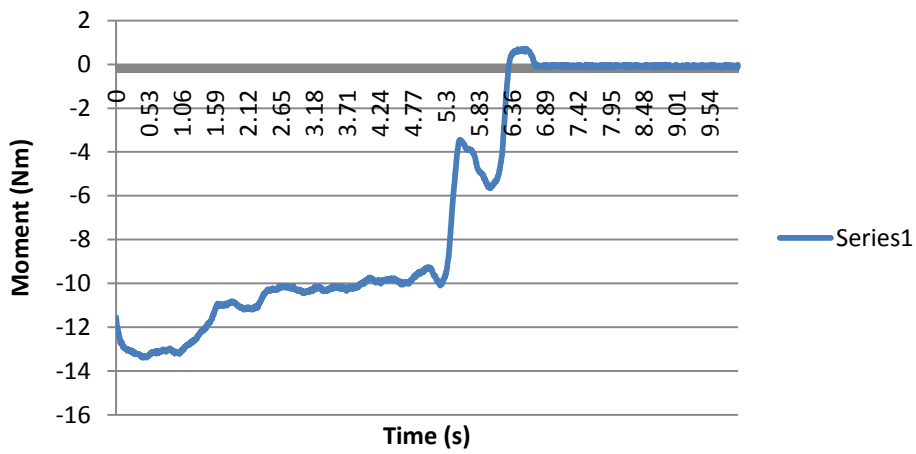

Alt 2 Elp CCW Average My

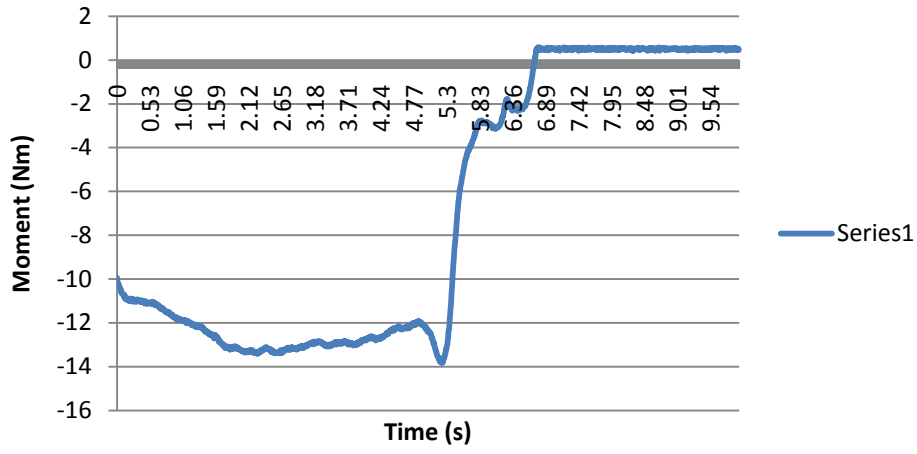

Alt 2 Elp CCW Average Mz

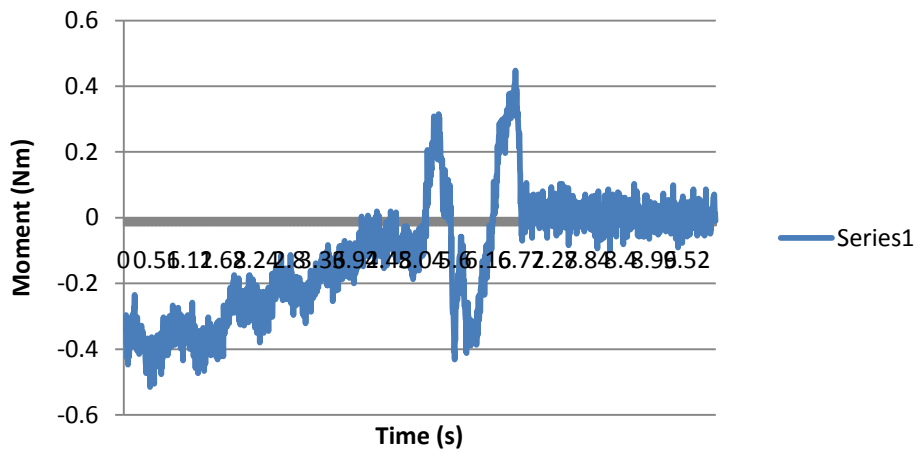

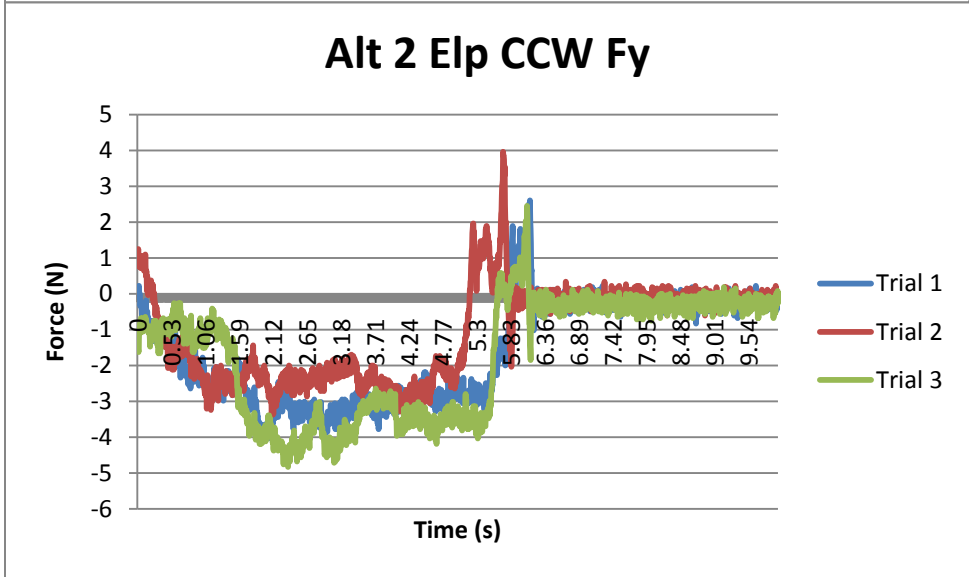
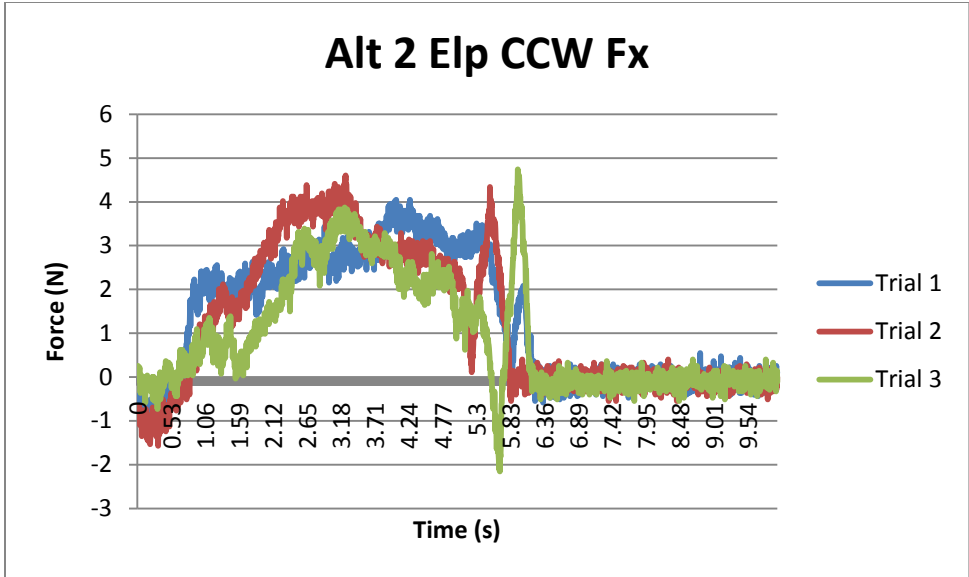

Alt 2 Elp CCW Fz

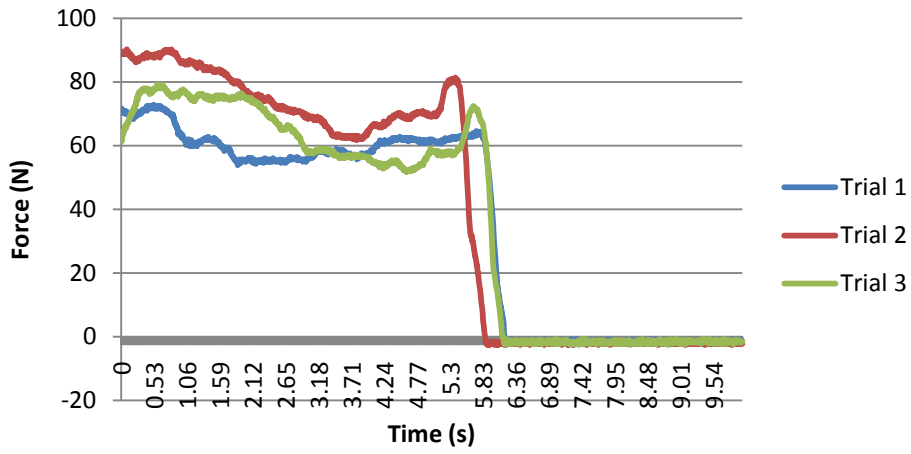

Alt 2 Elp CCW Mx

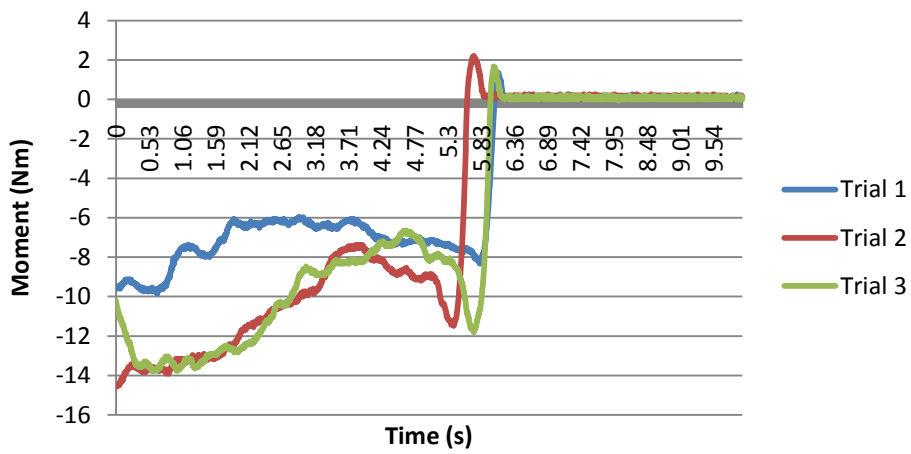

Alt 2 Elp CCW My

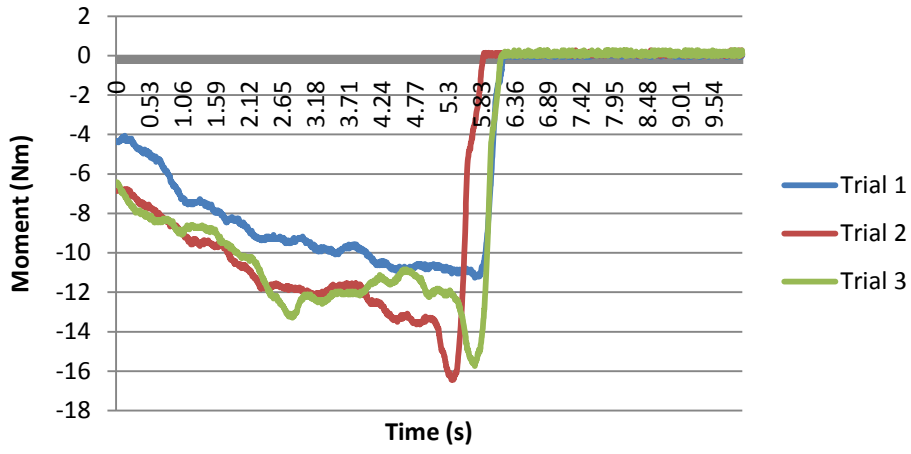

Alt 2 Elp CCW Mz

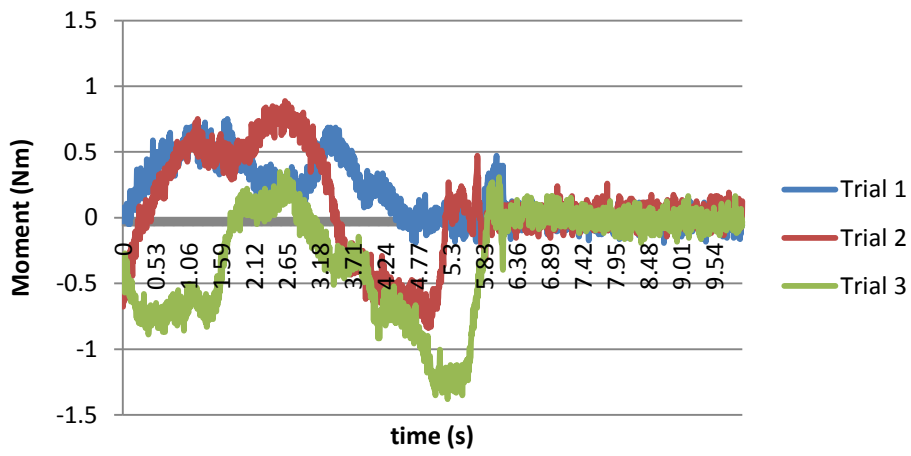

Alt 2 Elp CCW Average Fx

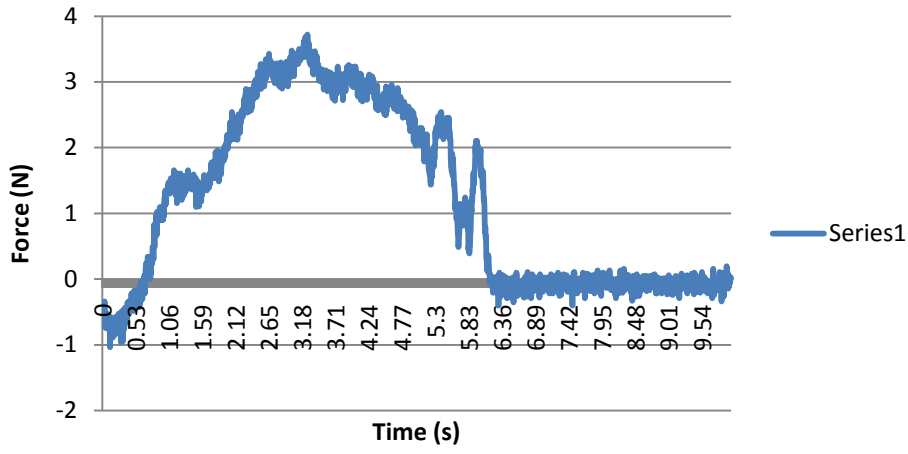

Alt 2 Elp CCW Average Fy

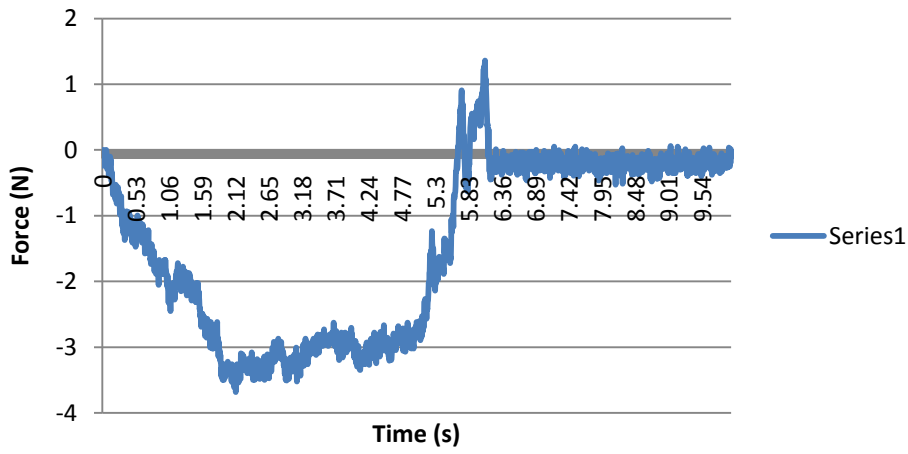

Alt 2 Elp CCW Average Fz

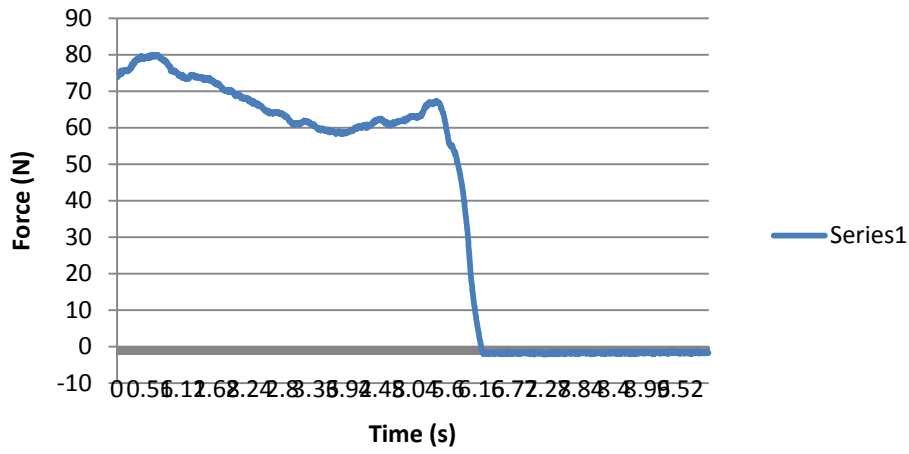

Alt 2 Elp CCW Average Mx

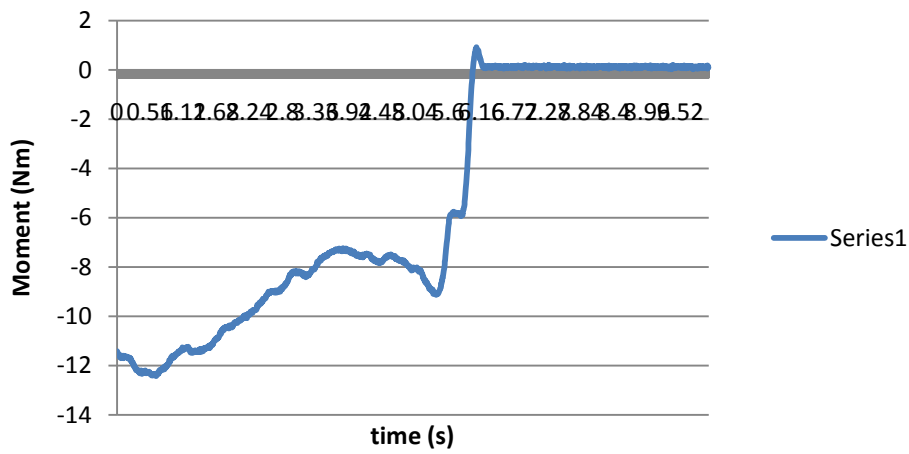

Alt 2 Elp CCW Average My

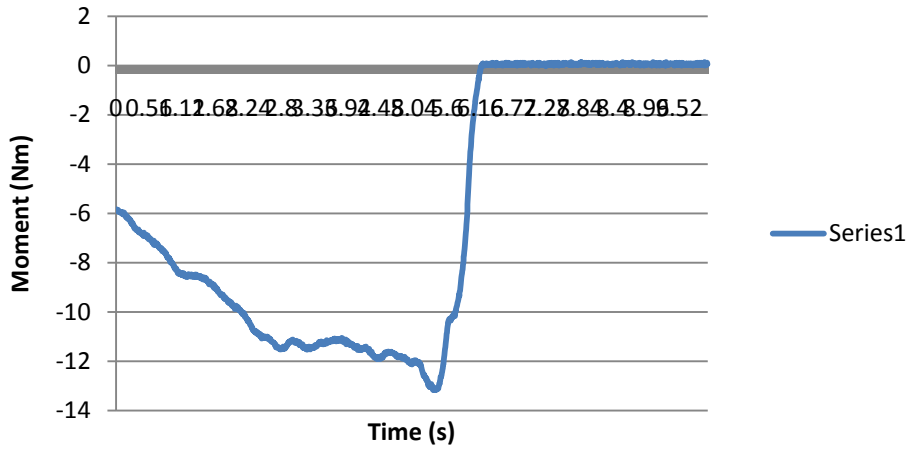

Alt 2 Elp CCW Average Mz

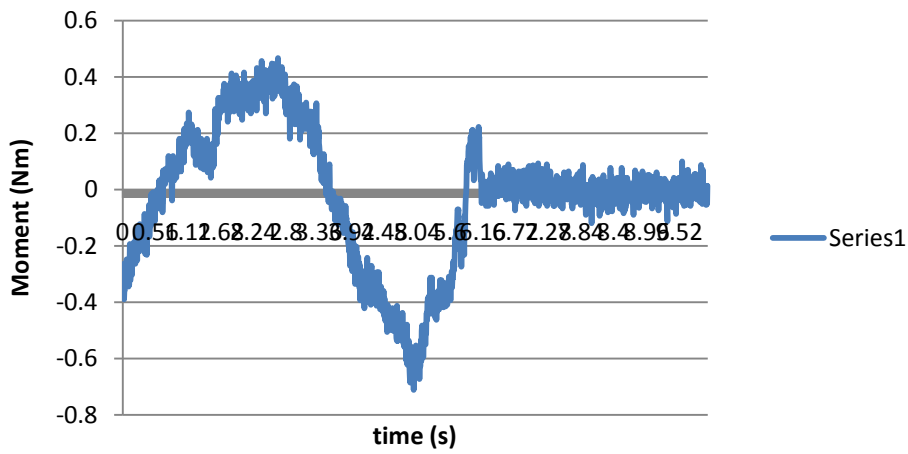

Alt 2 Vertical Linear Fx

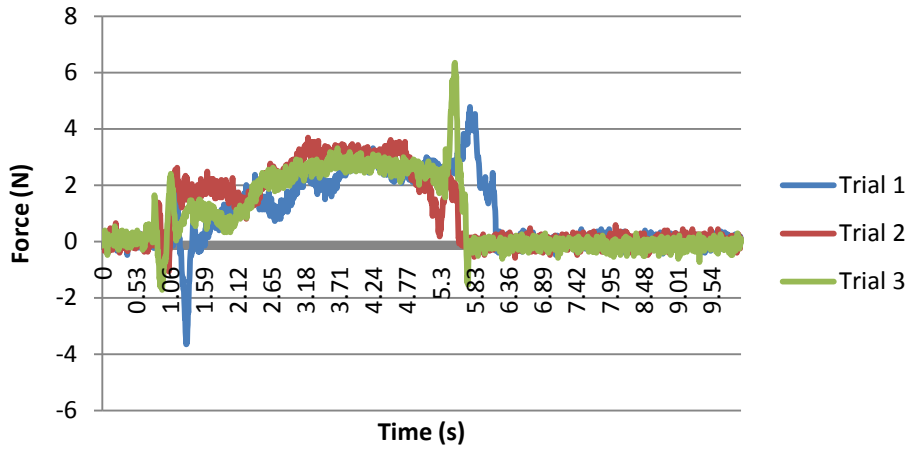

Alt 2 Vertical Linear Fy

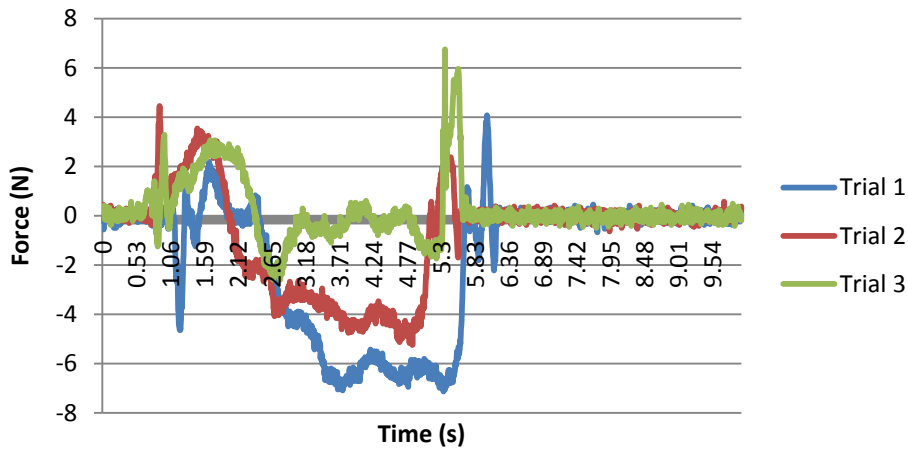

Alt 2 Vertical Linear Fz

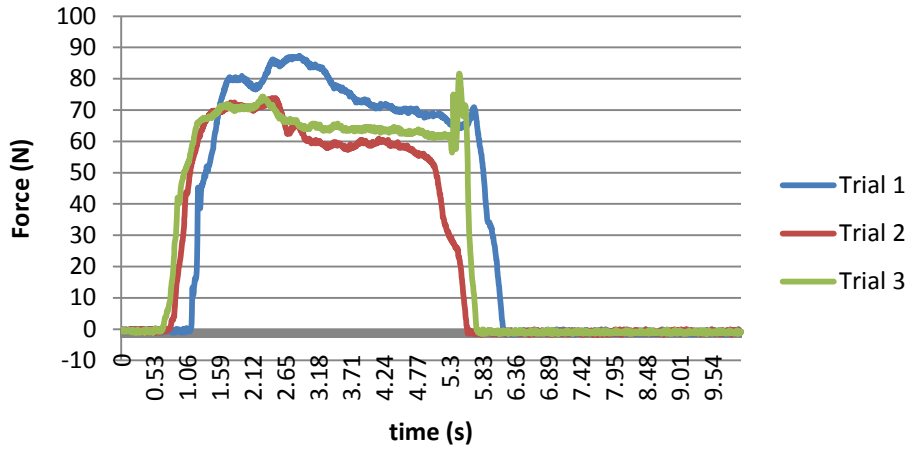

Alt 2 Vertical Linear Mx

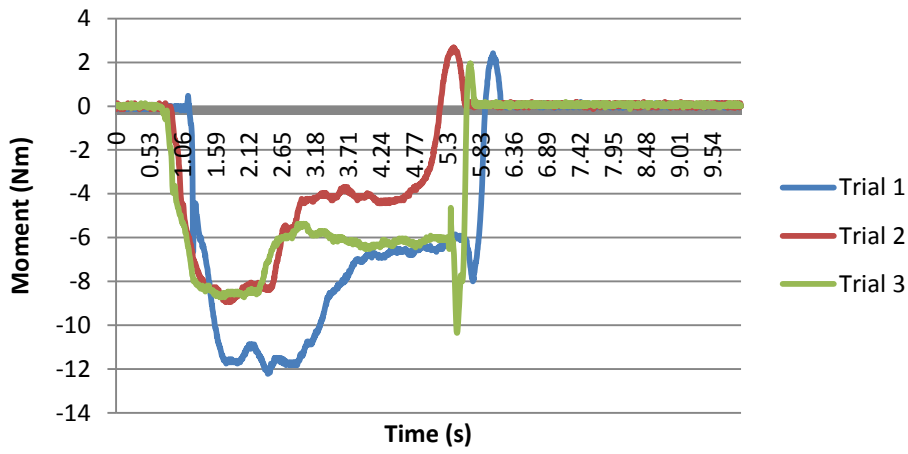

Alt 2 Vertical Linear My

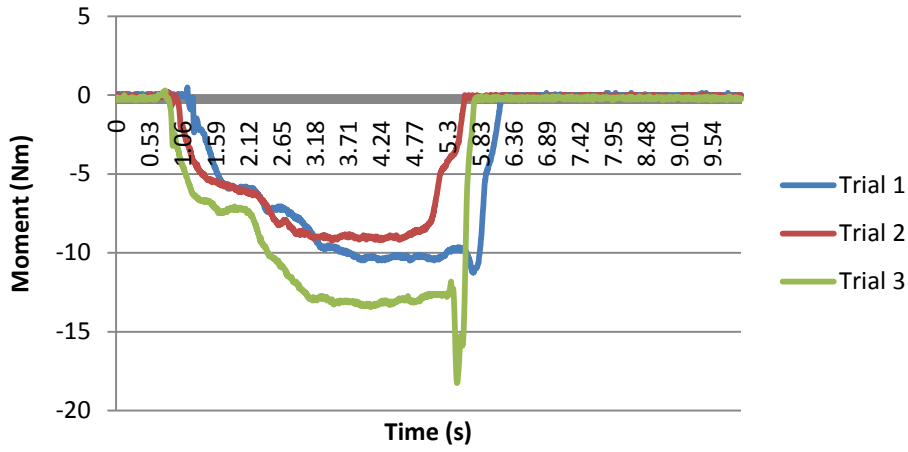

Alt 2 Vertical Linear Mz

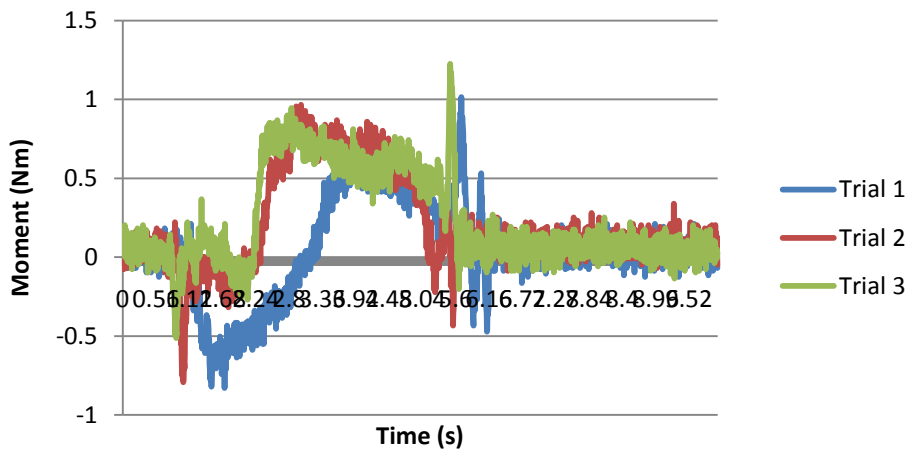

Alt 2 Vertical Linear Average Fx

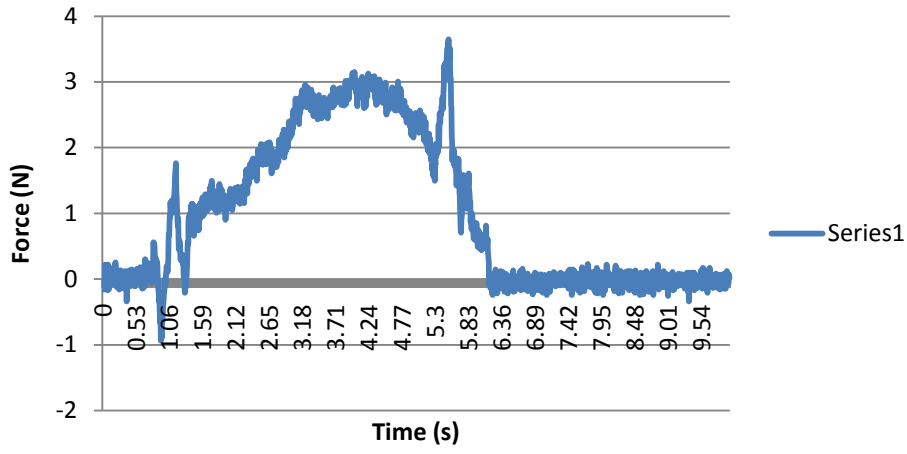

Alt 2 Vertical Linear Average Fy

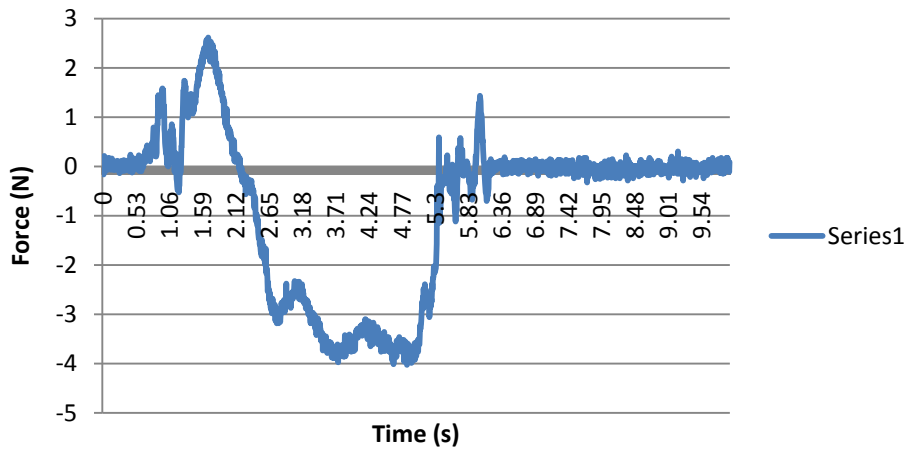

Alt 2 Vertical Linear Average Fz

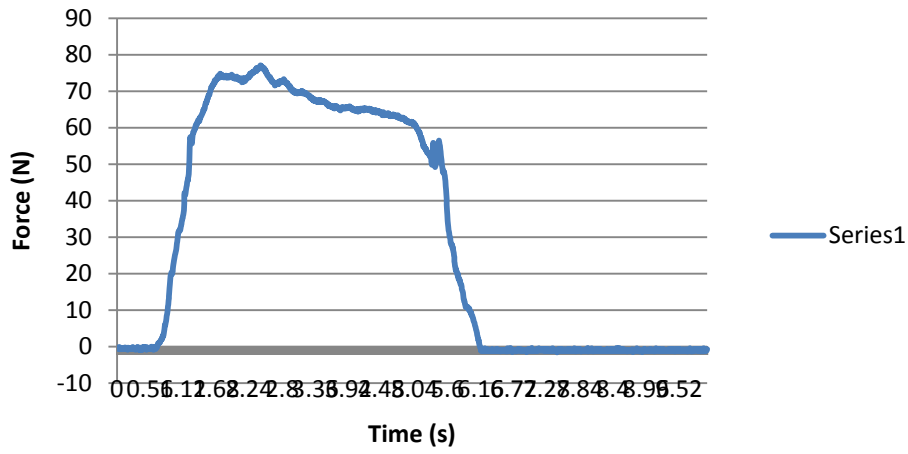

Alt 2 Vertical Linear Average Mx

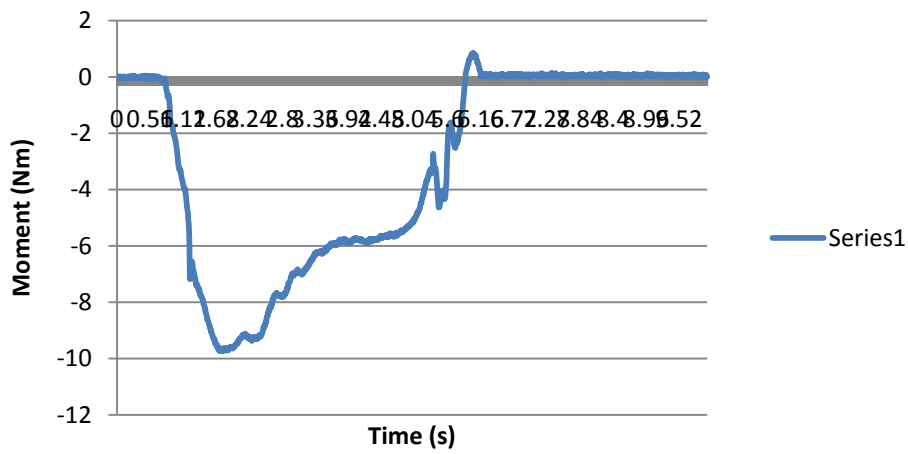

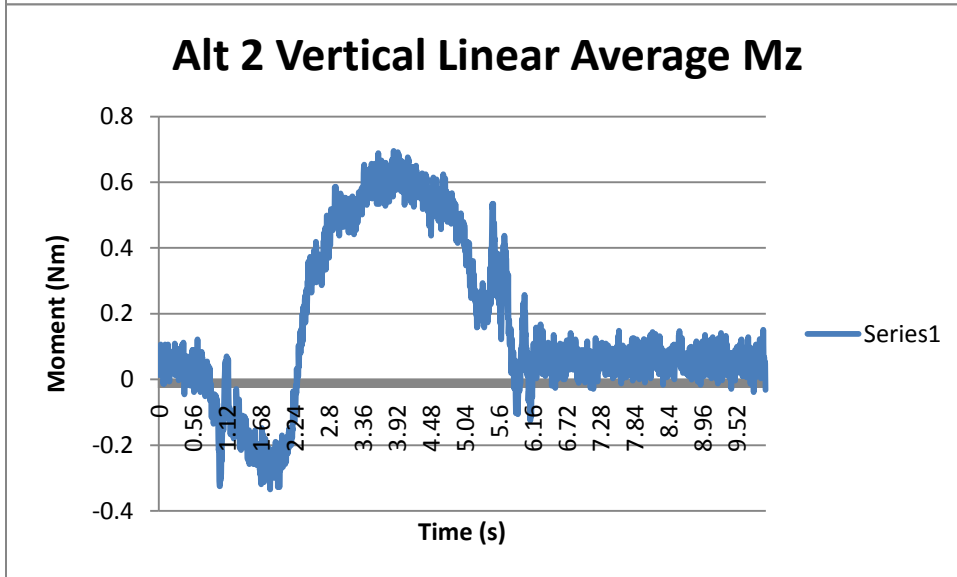
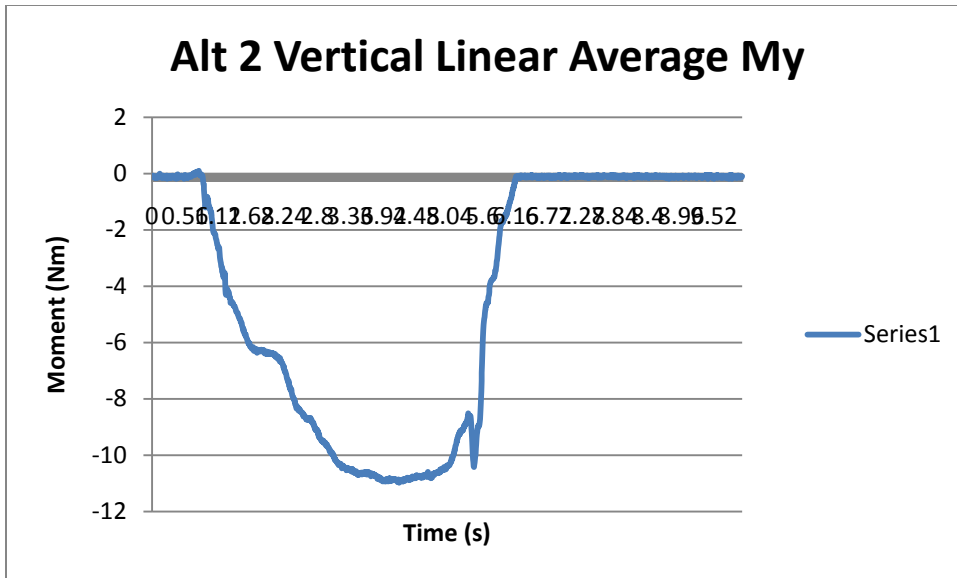

Alternative 3

Alt 3 Circ CCW Fx

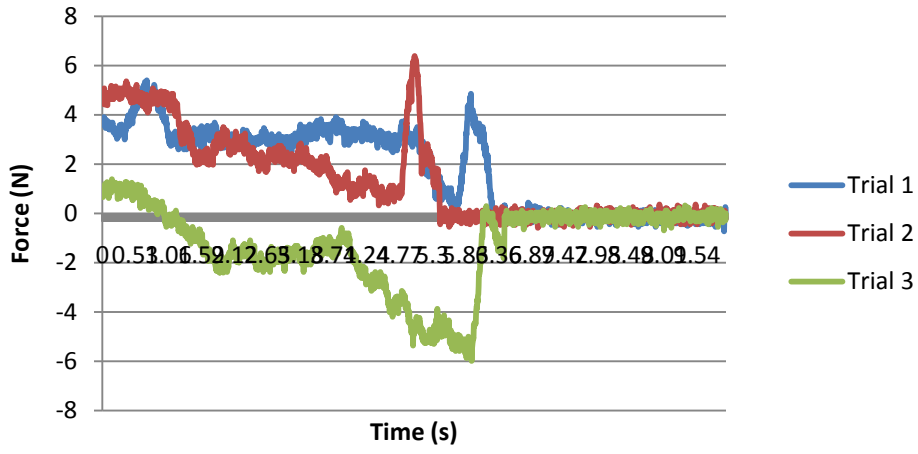

Alt 3 Circ CCW Fy

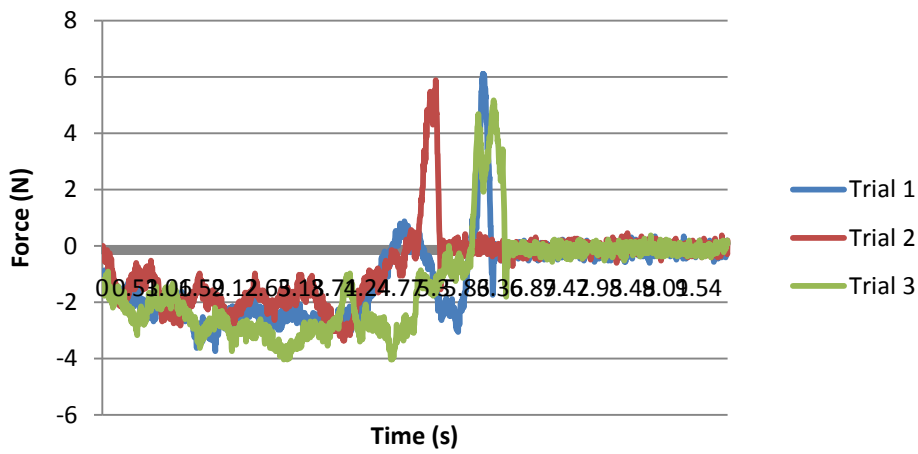

Alt 3 Circ CCW Fz

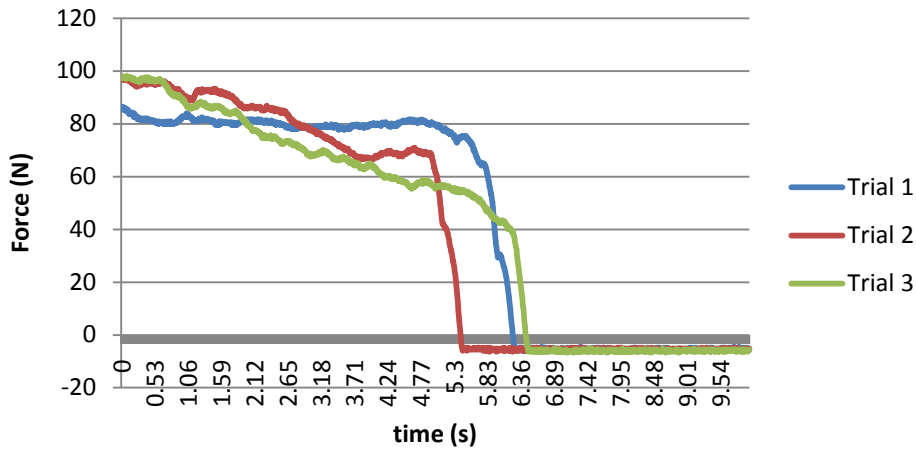

Alt 3 Circ CCW Mx

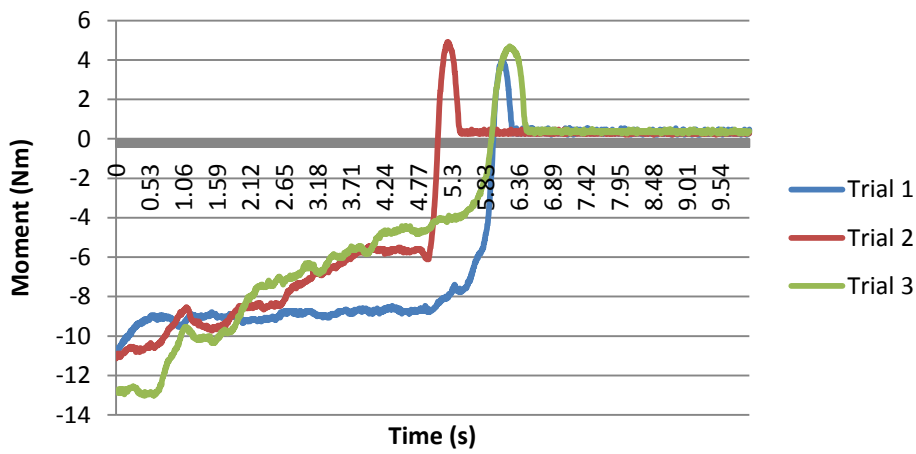

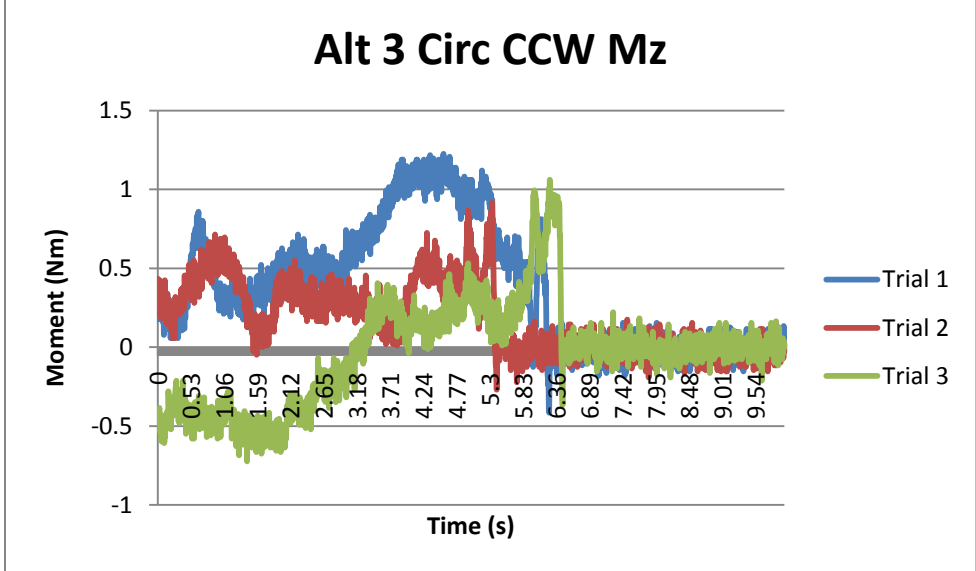
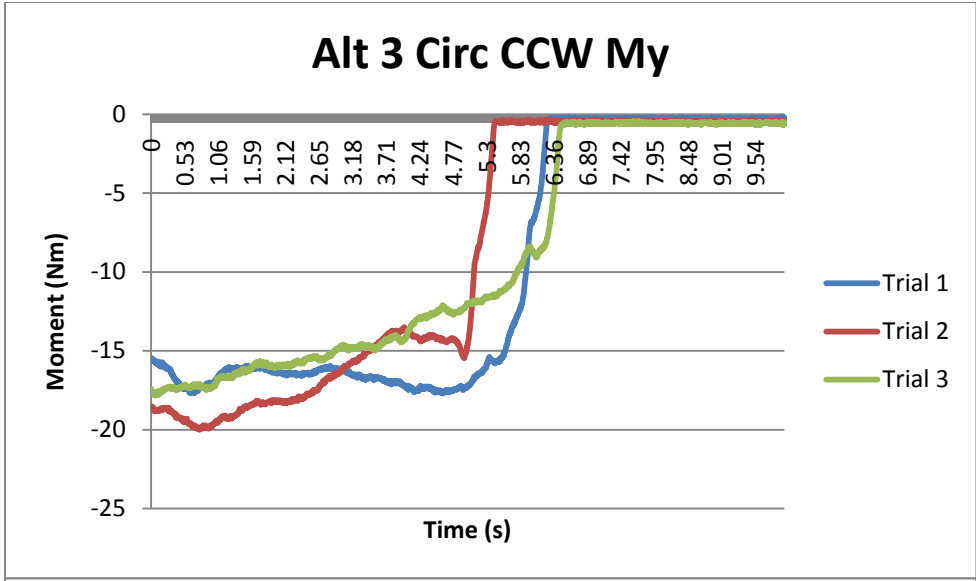

Alt 3 Circ CCW Average Fx

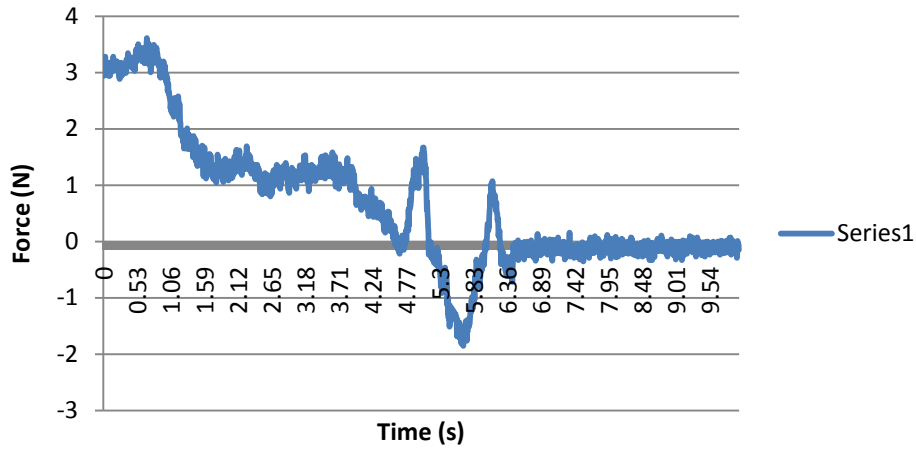

Alt 3 Circ CCW Average Fy

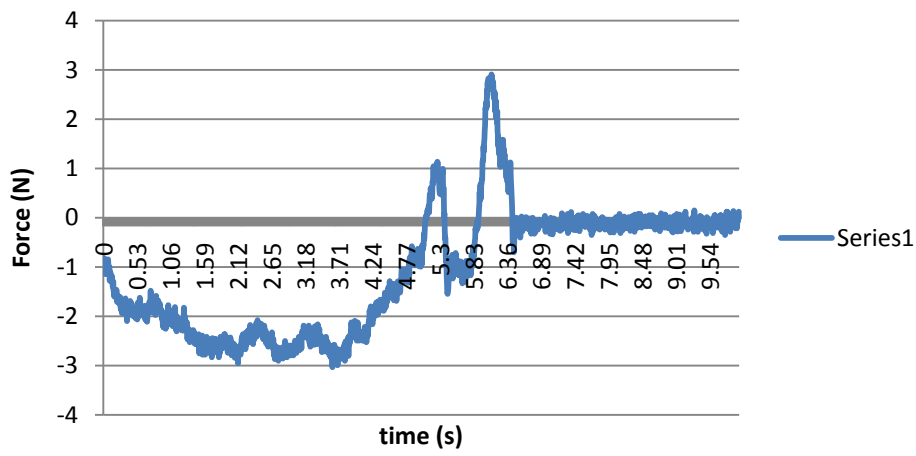

Alt 3 Circ CCW Average Fz

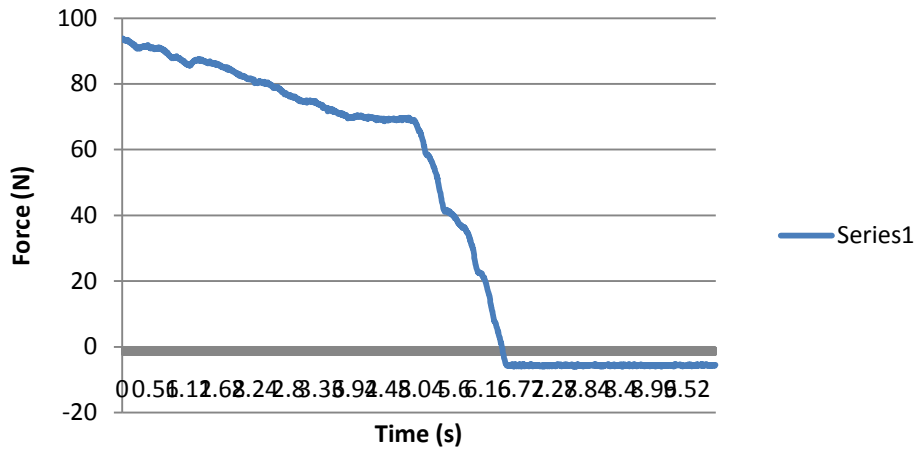

Alt 3 Circ CCW Average Mx

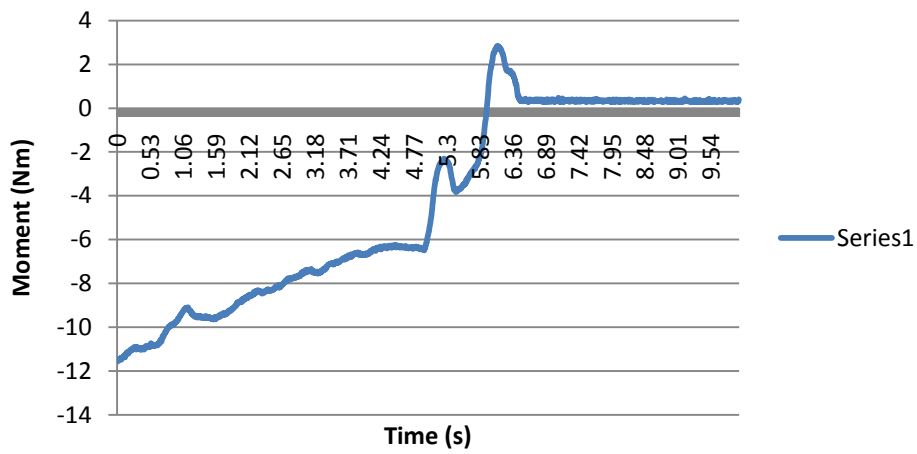

Alt 3 Circ CCW Average My

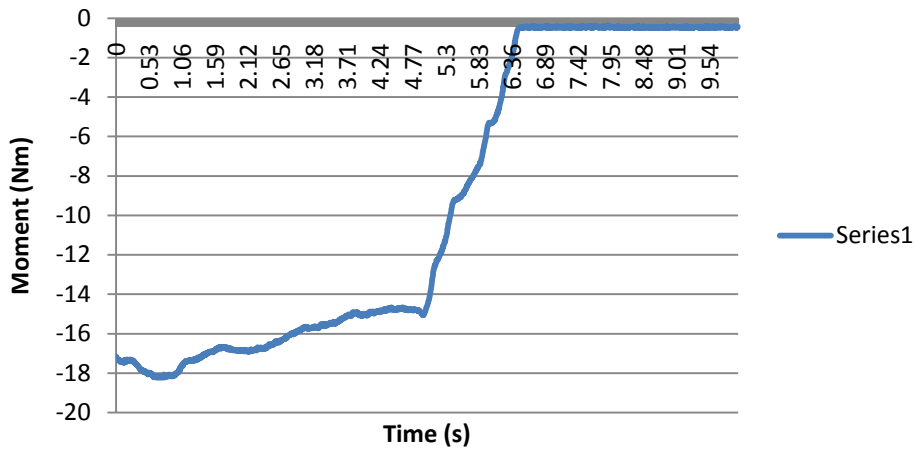

Alt 3 Circ CCW Average Mz

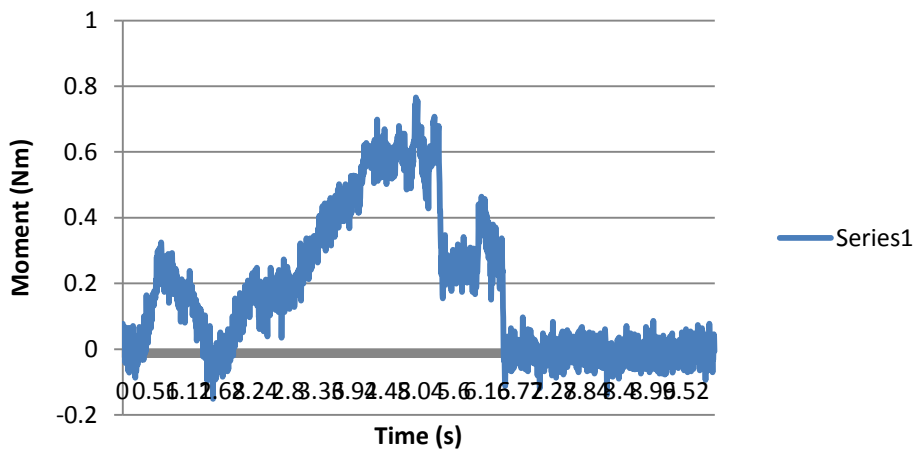

Alt 3 Circ CW Fx

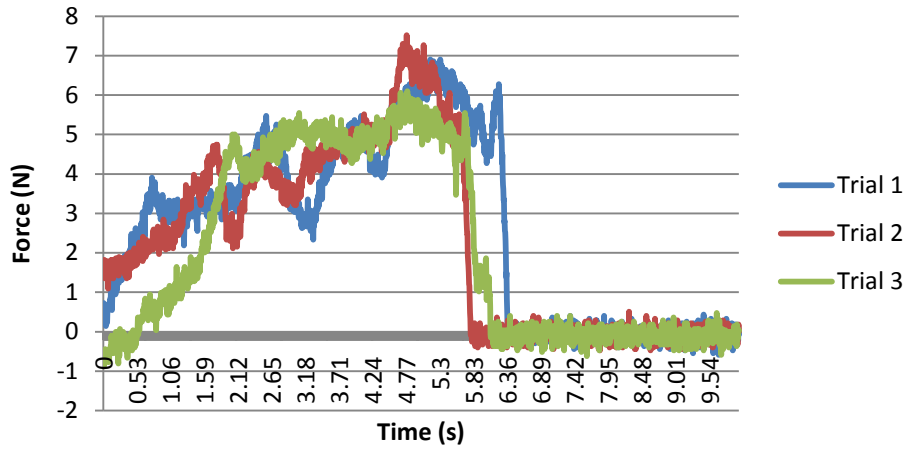

Alt 3 Circ CW Fy

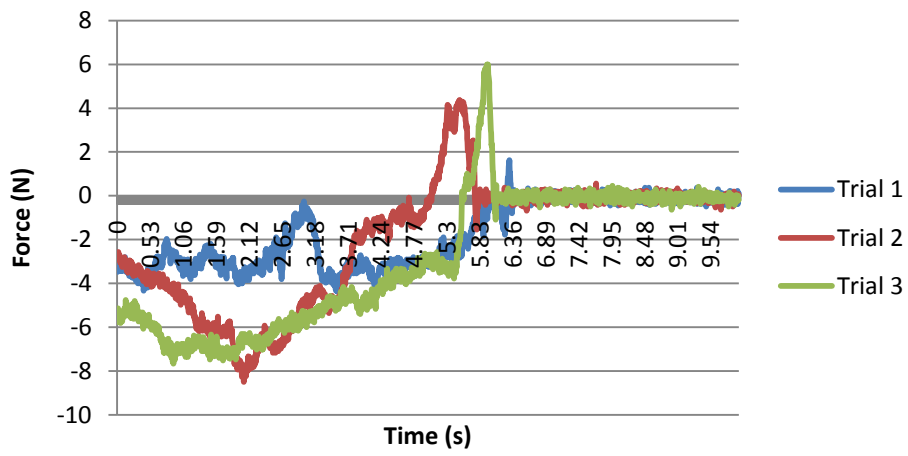

Alt 3 Circ CW Fz

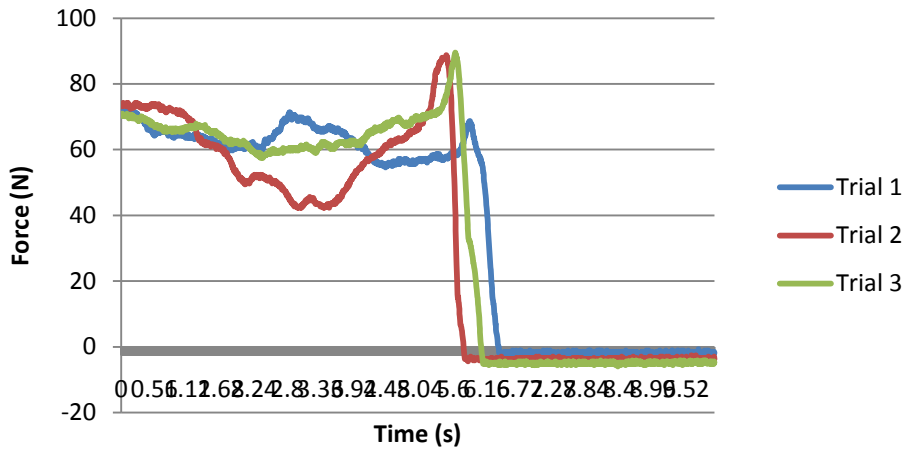

Alt 3 Circ CW Mx

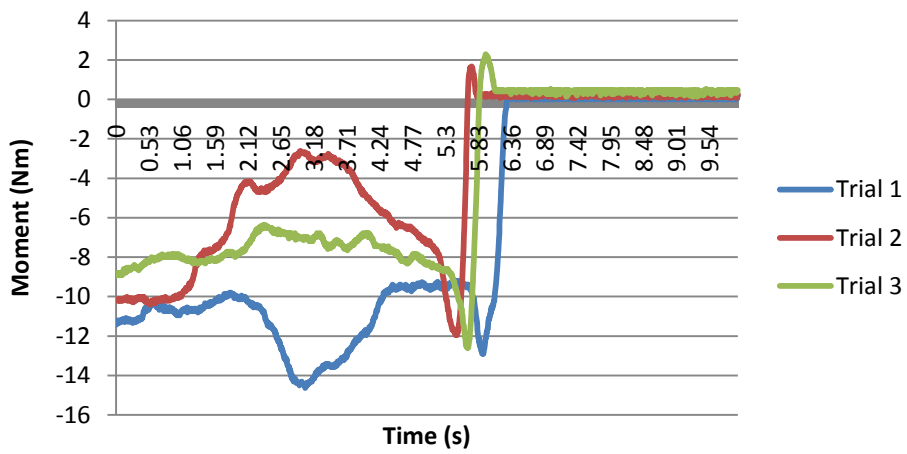

Alt 3 Circ CW My

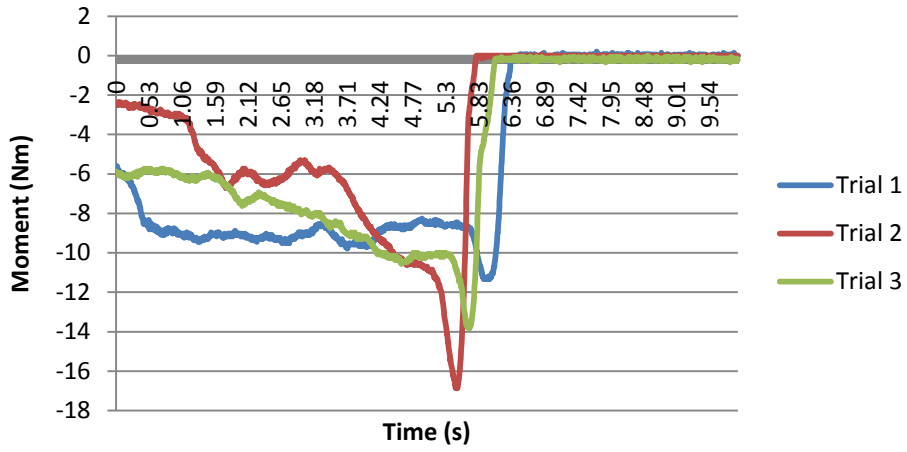

Alt 3 Circ CW Mz

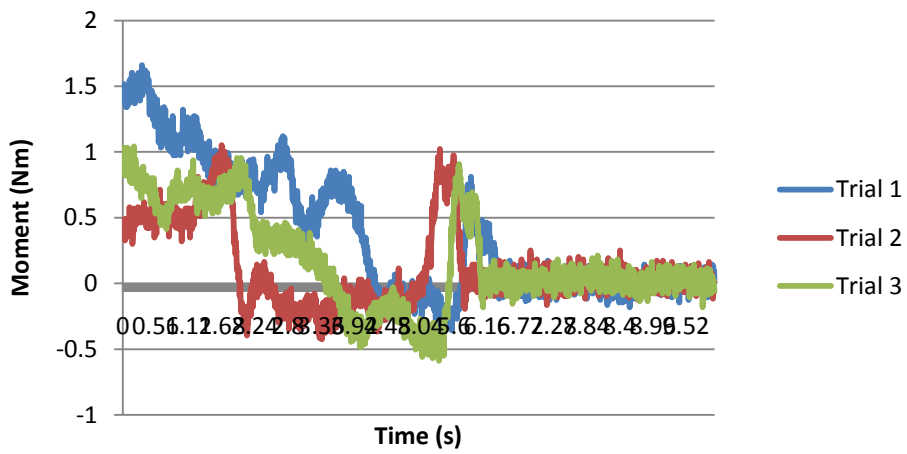

Alt 3 Circ CW Average Fx

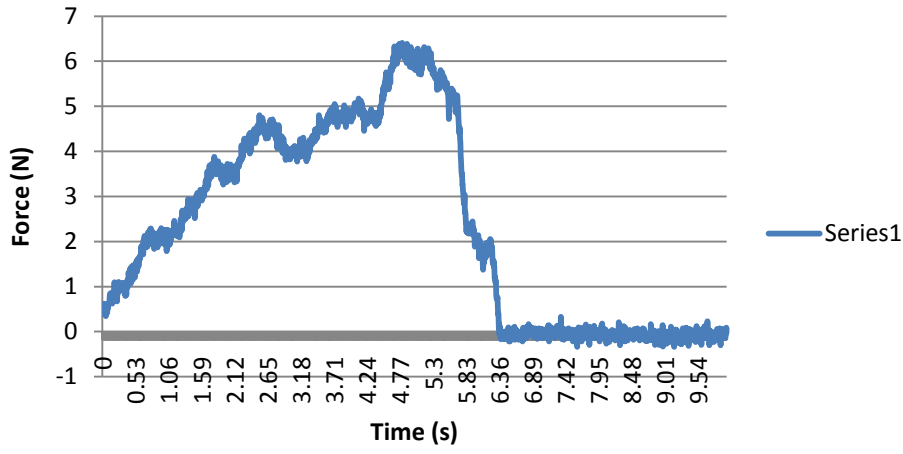

Alt 3 Circ CW Average Fy

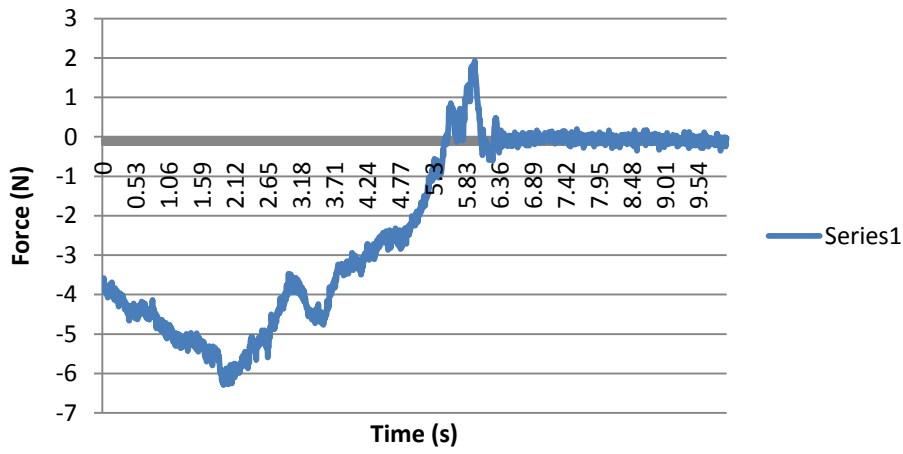

Alt 3 Circ CW Average Fz

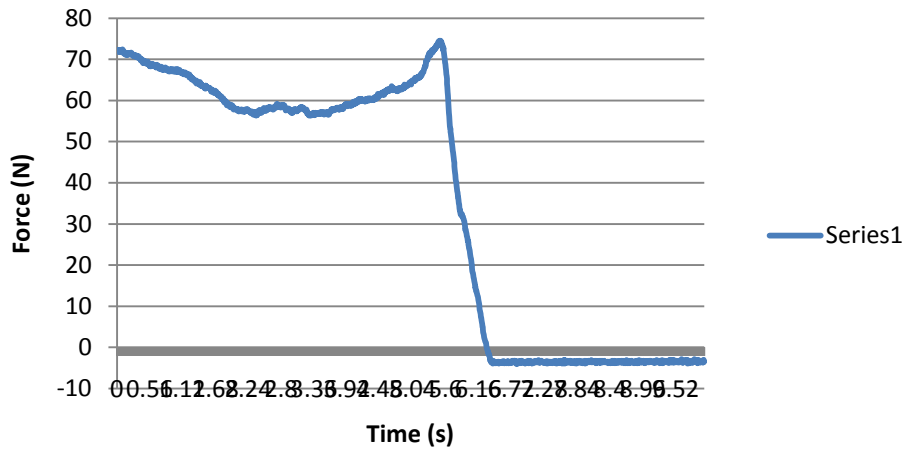

Alt 3 Circ CW Average Mx

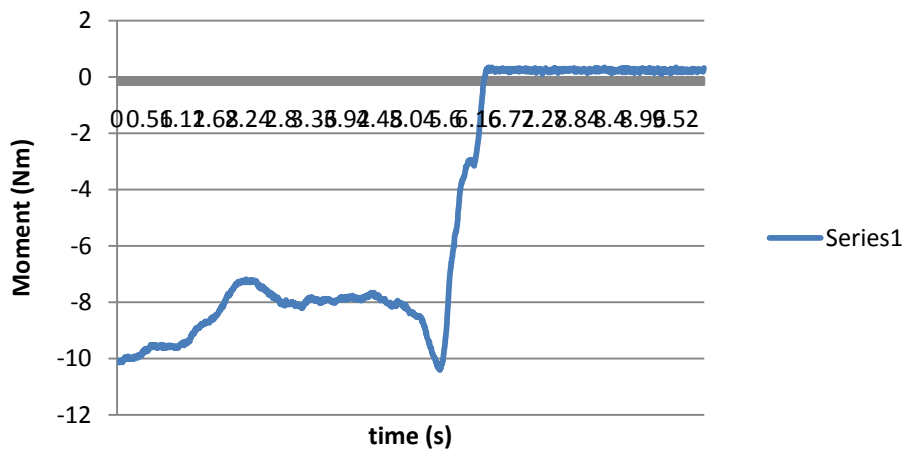

Alt 3 Circ CW Average My

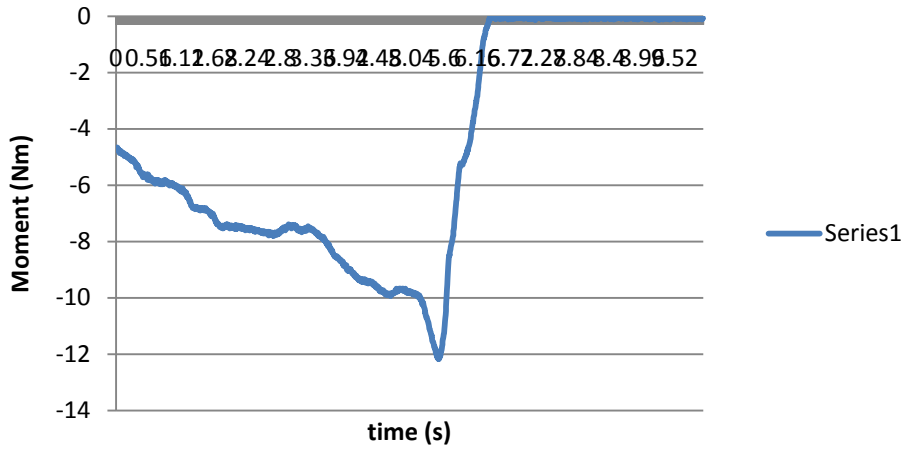

Alt 3 Circ CW Average Mz

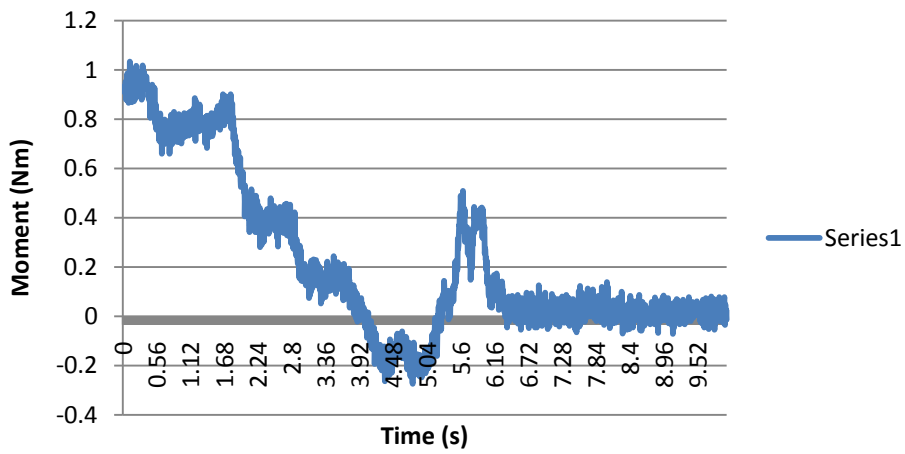

Alt 3 Elp CCW Fx

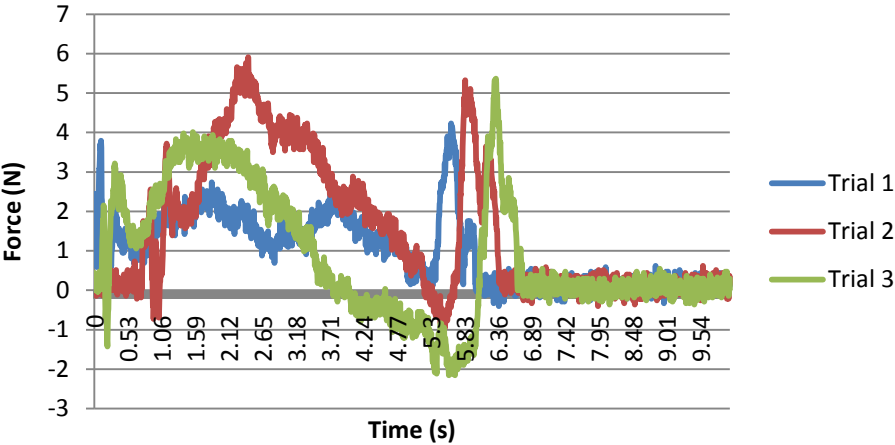

Alt 3 Elp CCW Fy

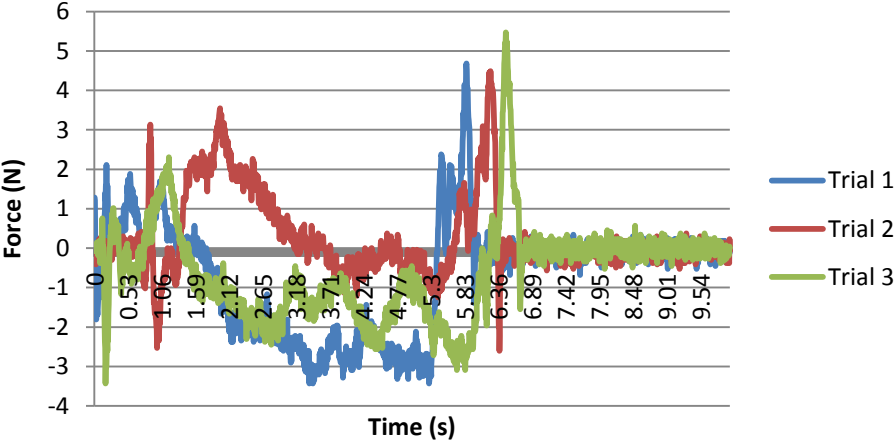

Alt 3 Elp CCW Fz

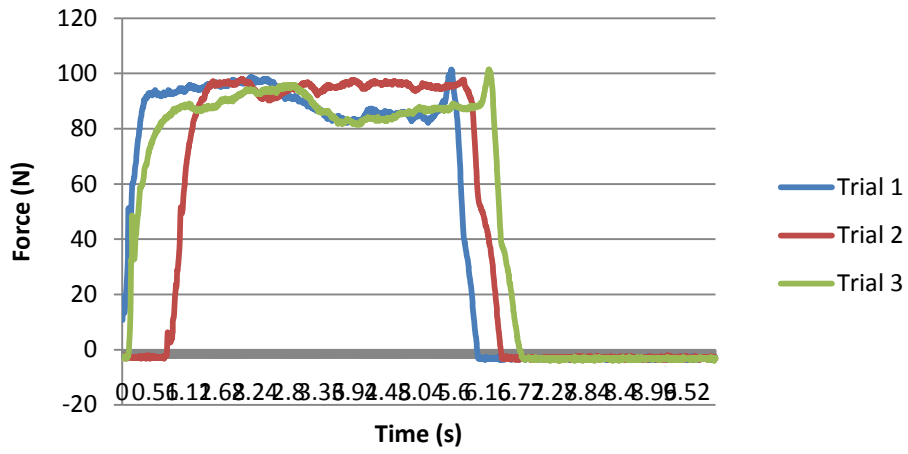

Alt 3 Elp CCW Mx

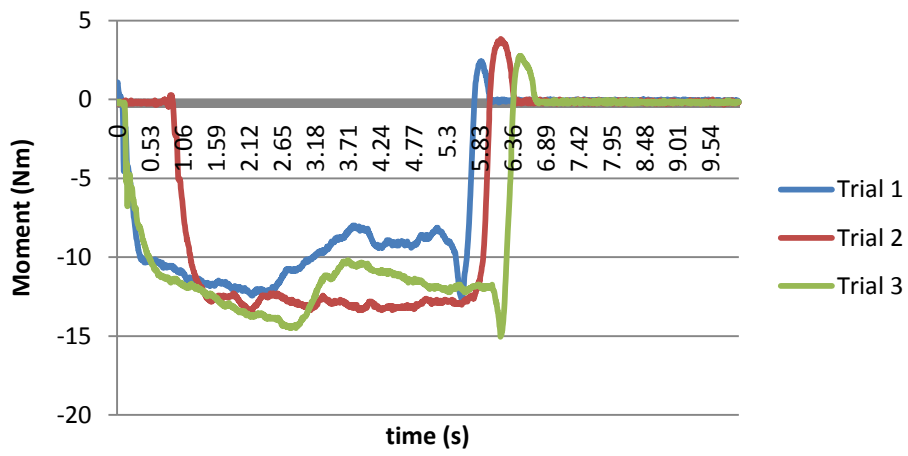

Alt 3 Elp CCW My

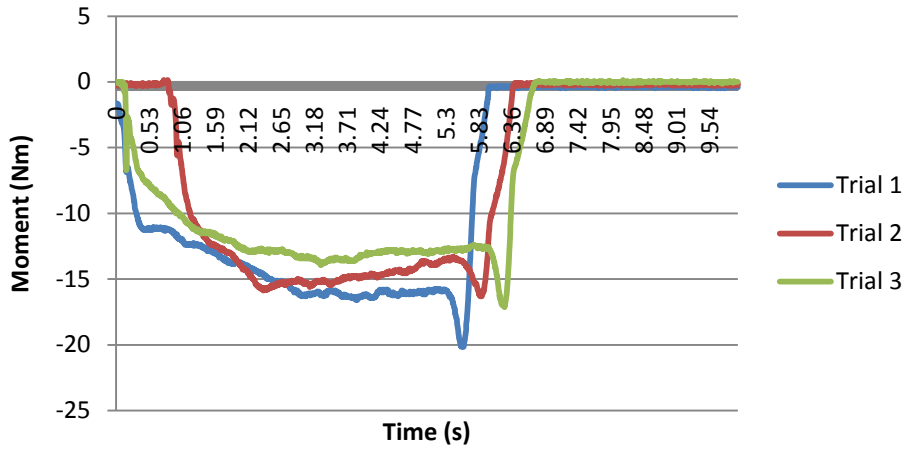

Alt 3 Elp CCW Mz

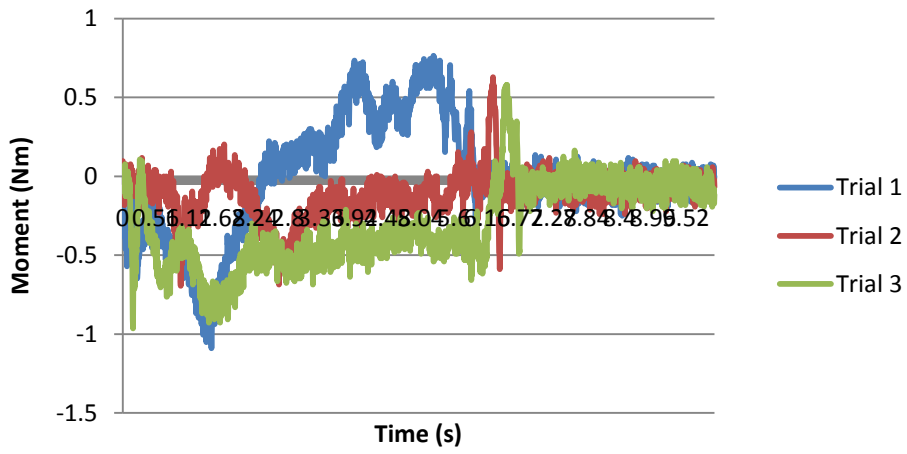

Alt 3 Elp CCW Average Fx

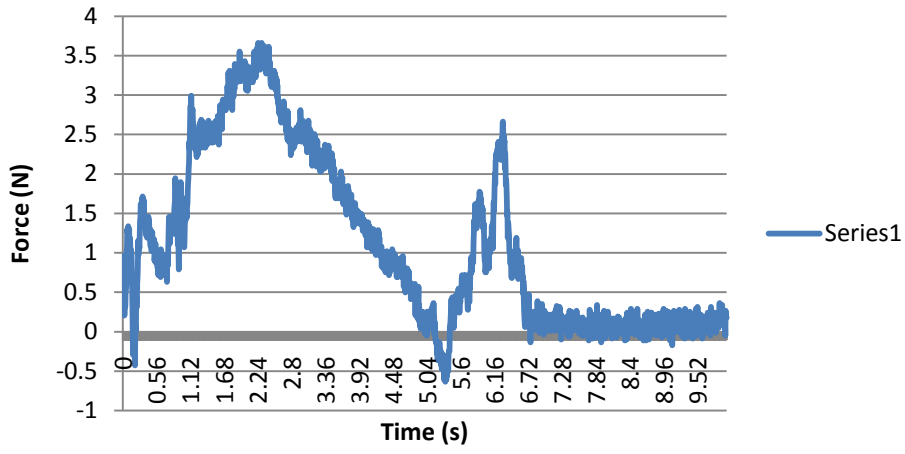

Alt 3 Elp CCW Average Fy

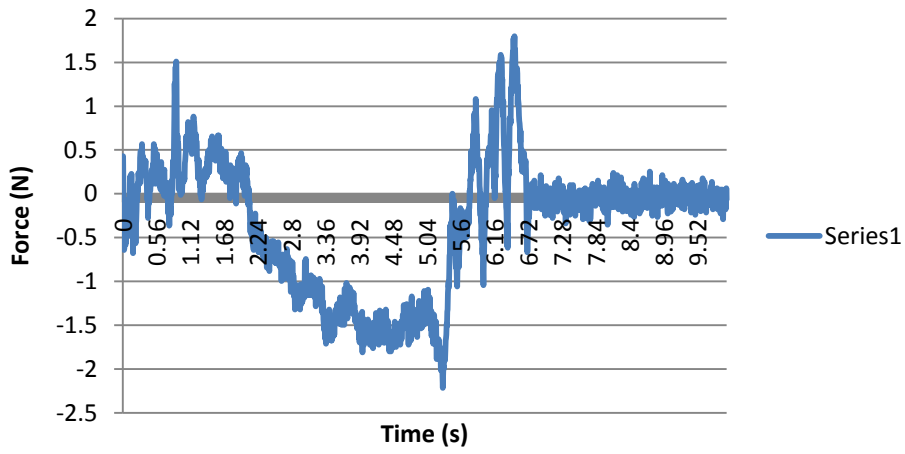

Alt 3 Elp CCW Average Fz

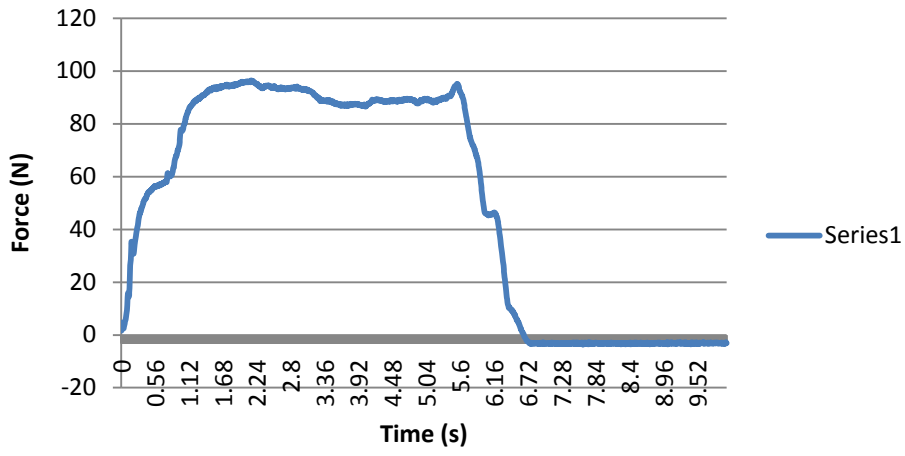

Alt 3 Elp CCW Average Mx

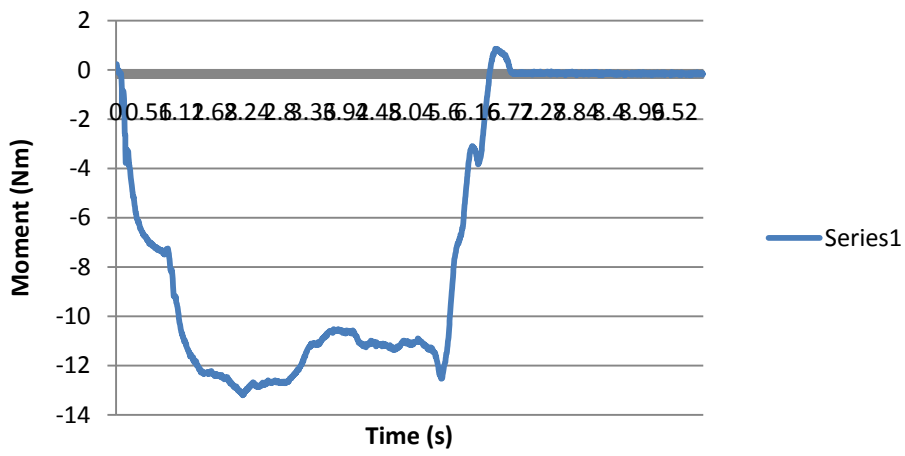

Alt 3 Elp CCW Average My

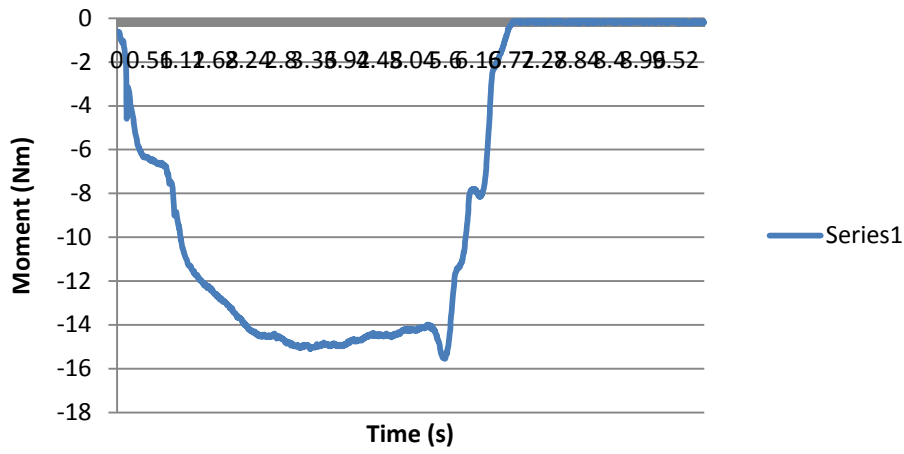

Alt 3 Elp CCW Average Mz

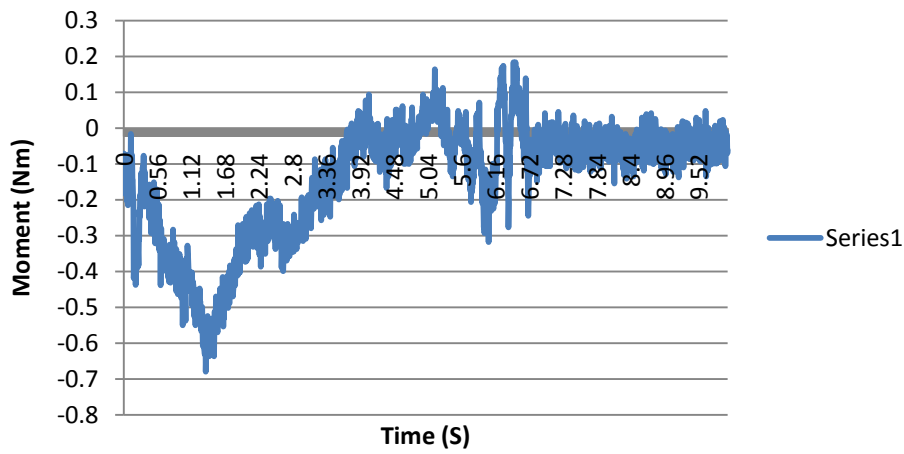

Alt 3 Elp CW Fx

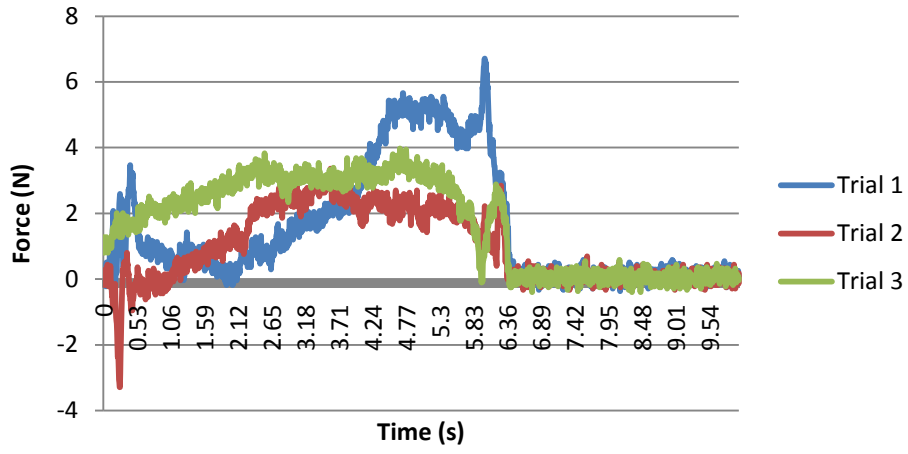

Alt 3 Elp CW Fy

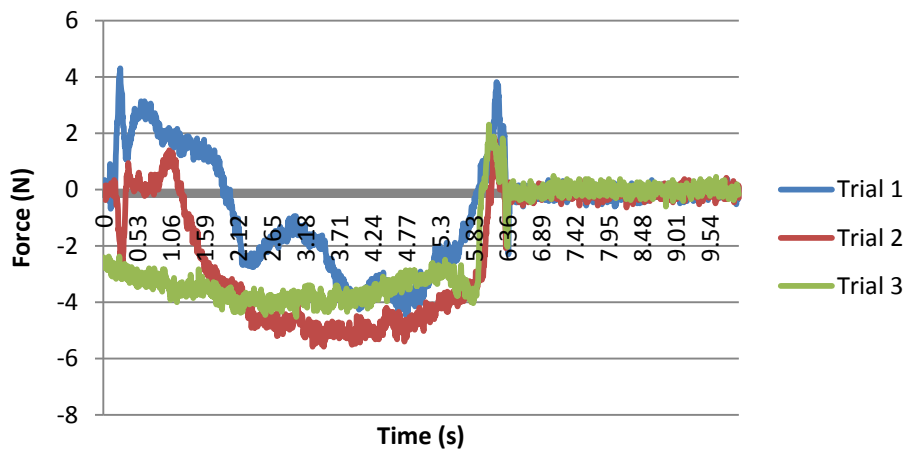

Alt 3 Elp CW Fz

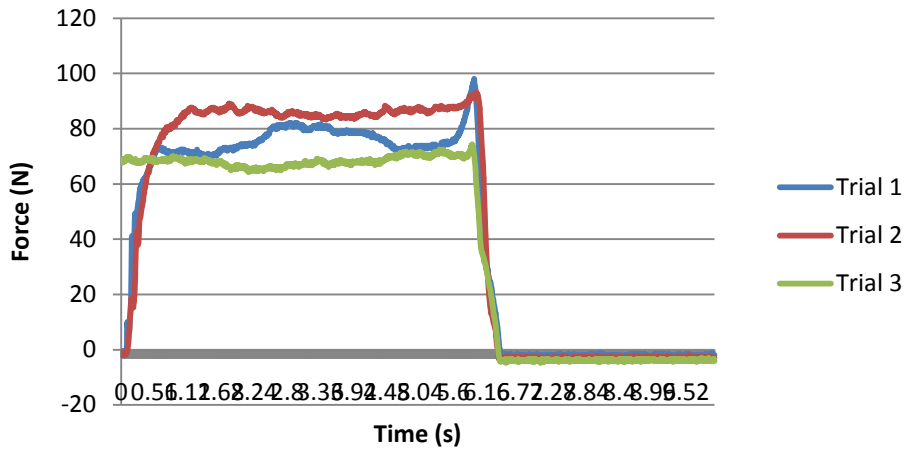

Alt 3 Elp CW Mx

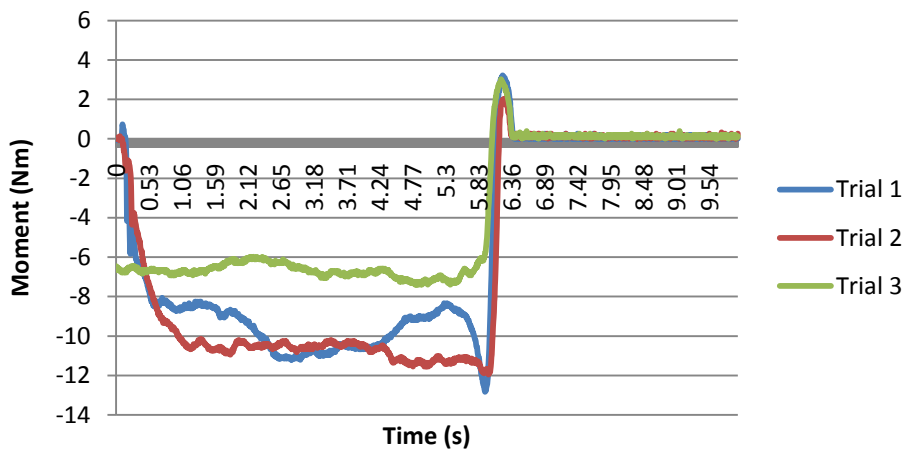

Alt 3 Elp CW My

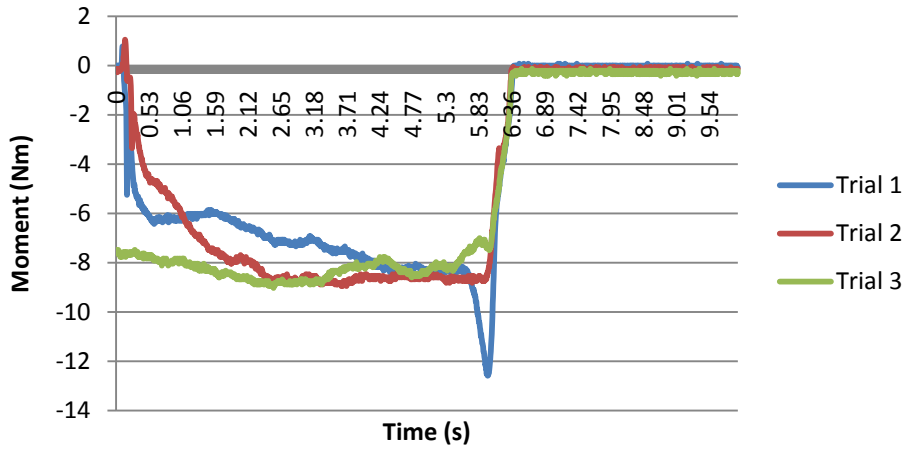

Alt 3 Elp CW Mz

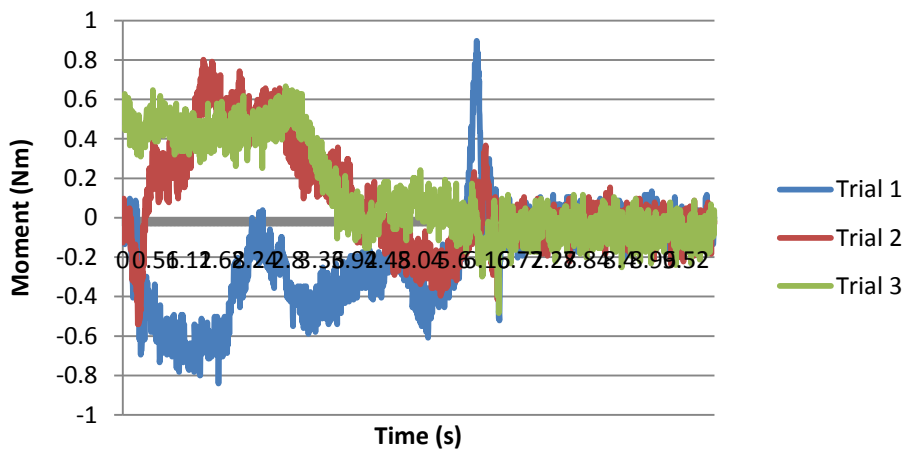

Alt 3 Elp CW Average Fx

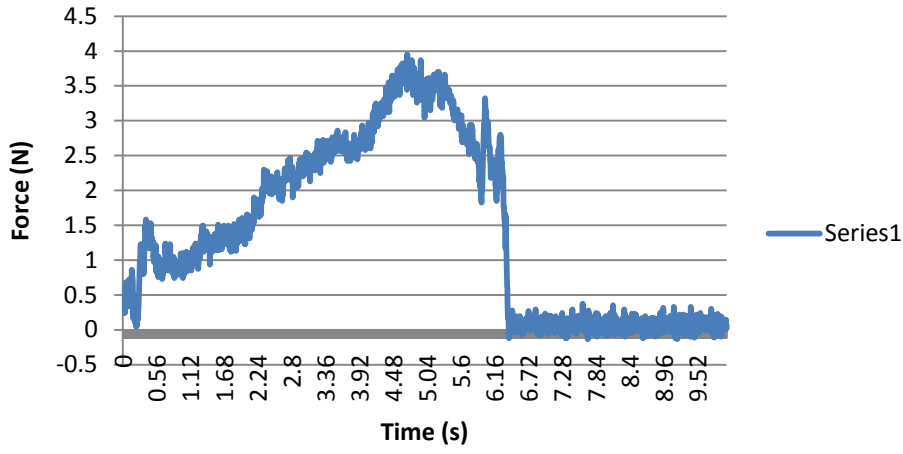

Alt 3 Elp CW Average Fy

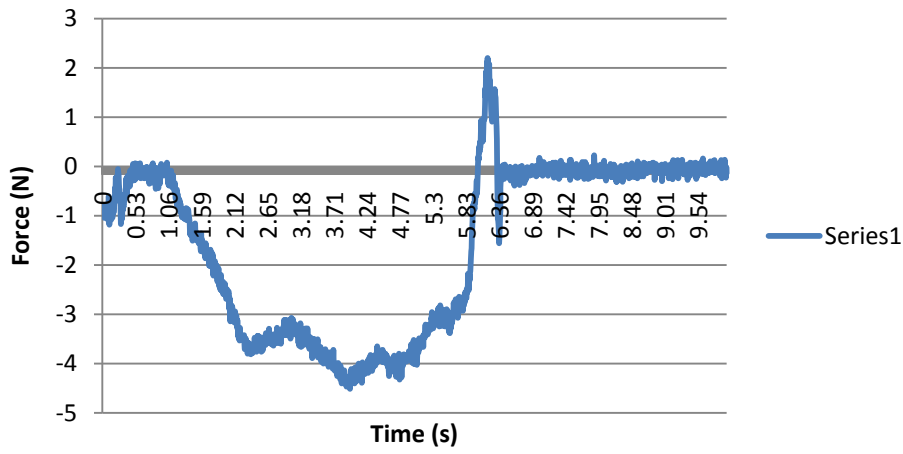

Alt 3 Elp CW Average Fz

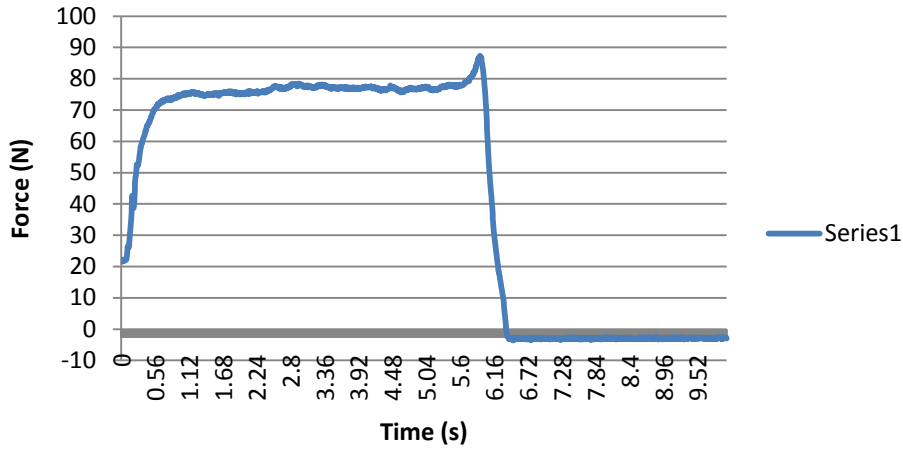

Alt 3 Elp CW Average Mx

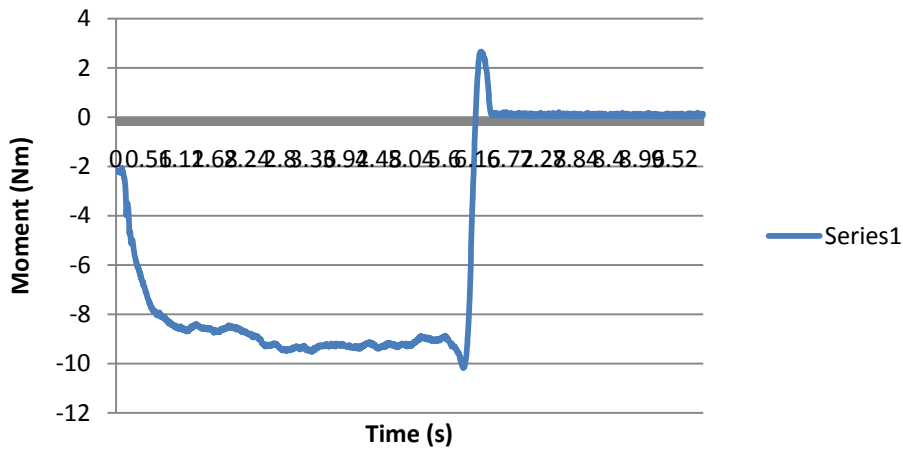

Alt 3 Elp CW Average My

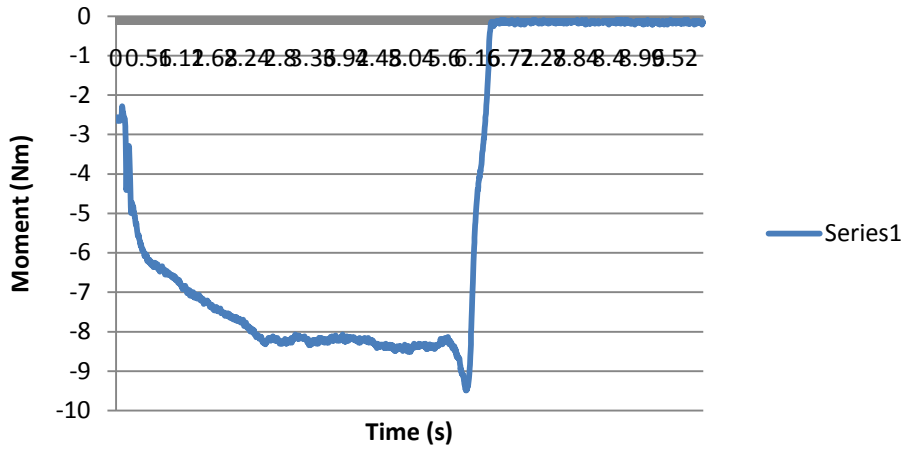

Alt 3 Elp CW Average Mz

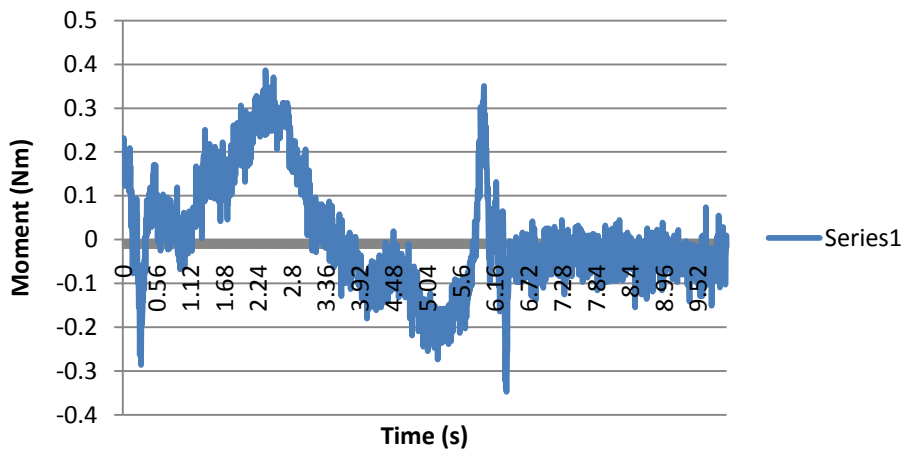

Alt 3 Vertical Linear Fx

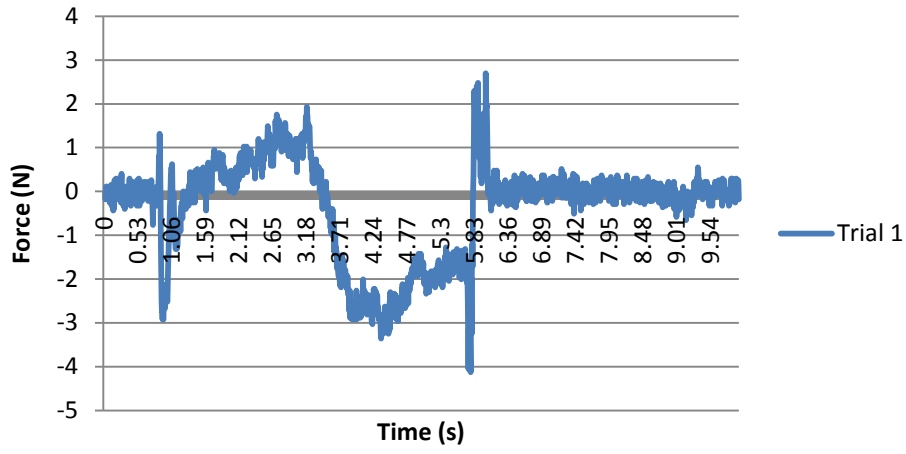

Alt 3 Vertical Linear Fy

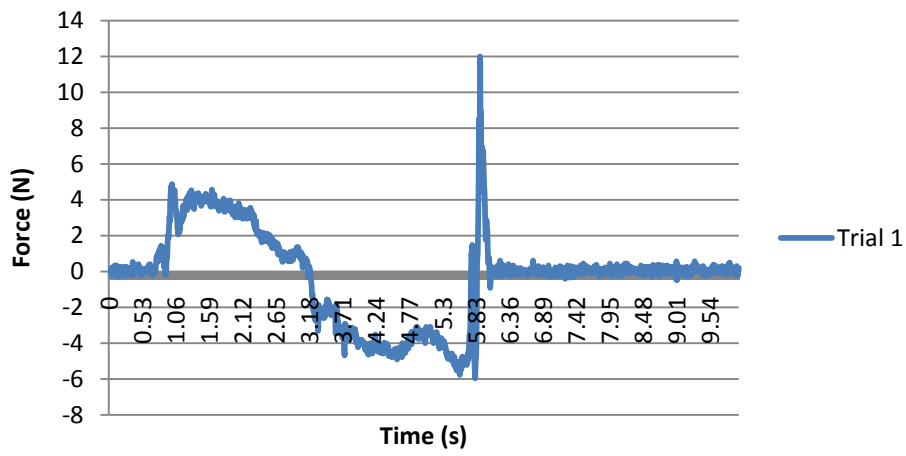

Alt 3 Vertical Linear Fz

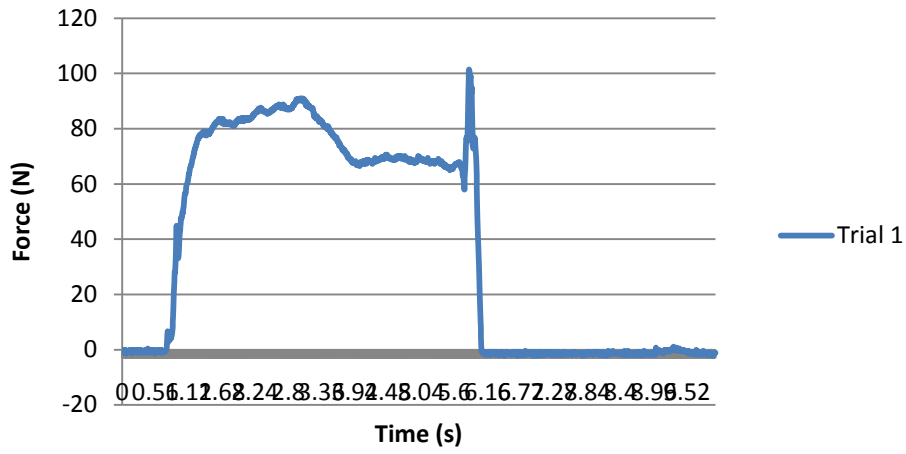

Alt 3 Vertical Linear Mx

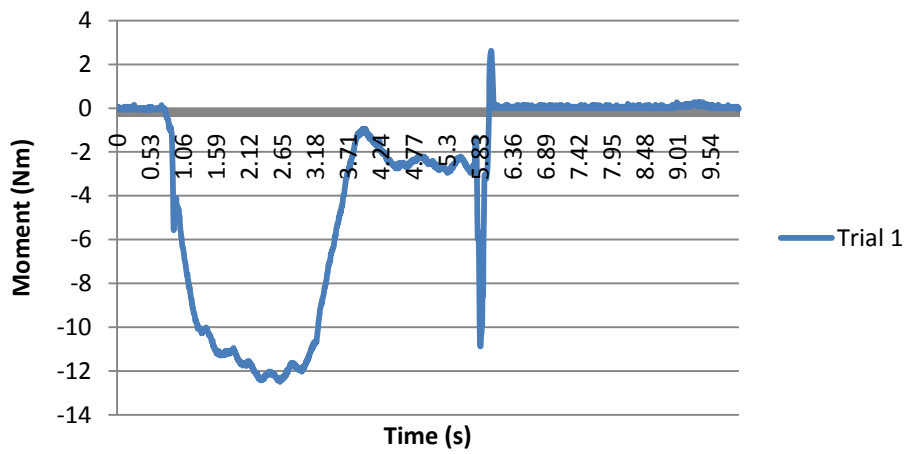

Alt 3 Vertical Linear My

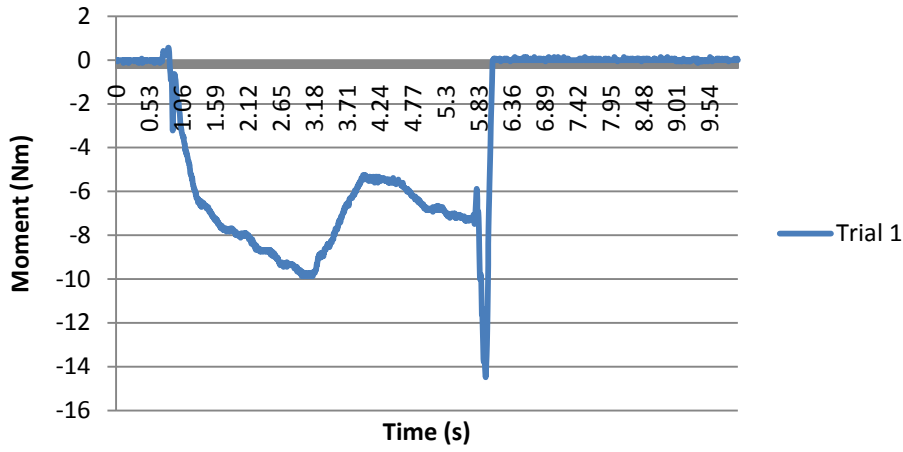

Alt 3 Vertical Linear Mz

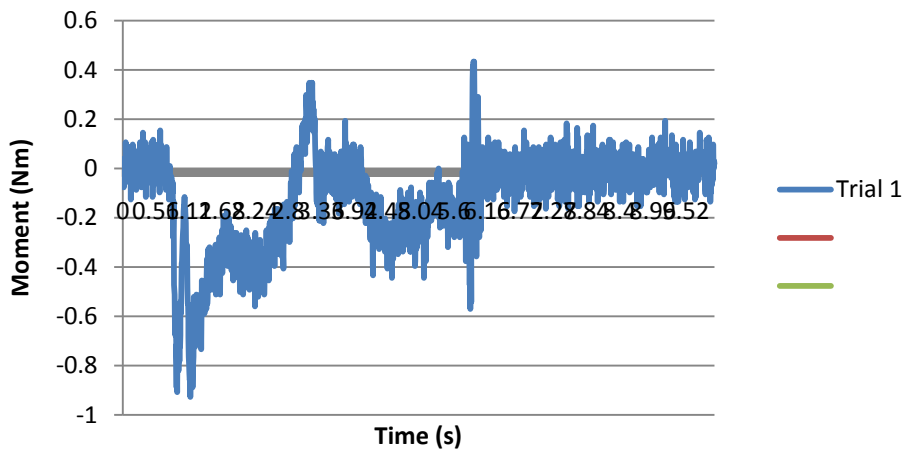

Alt 3 Vertical Linear Average Fx

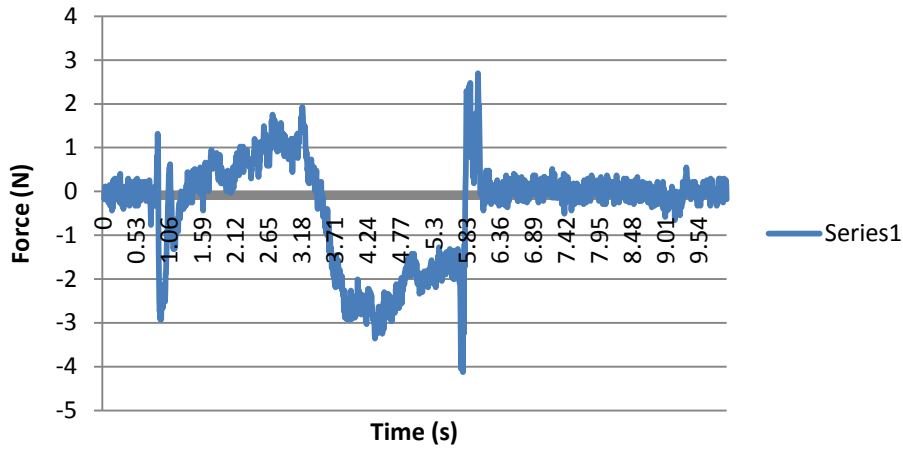

Alt 3 Vertical Linear Average Fy

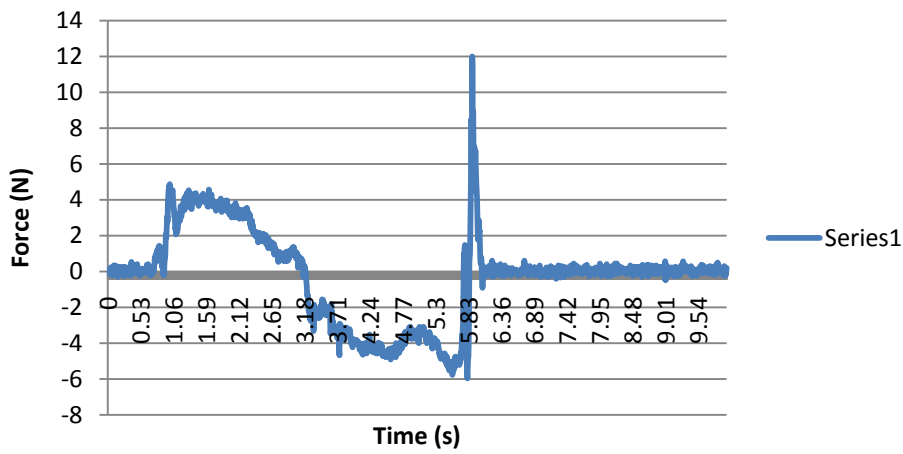

Alt 3 Vertical Linear Average Fz

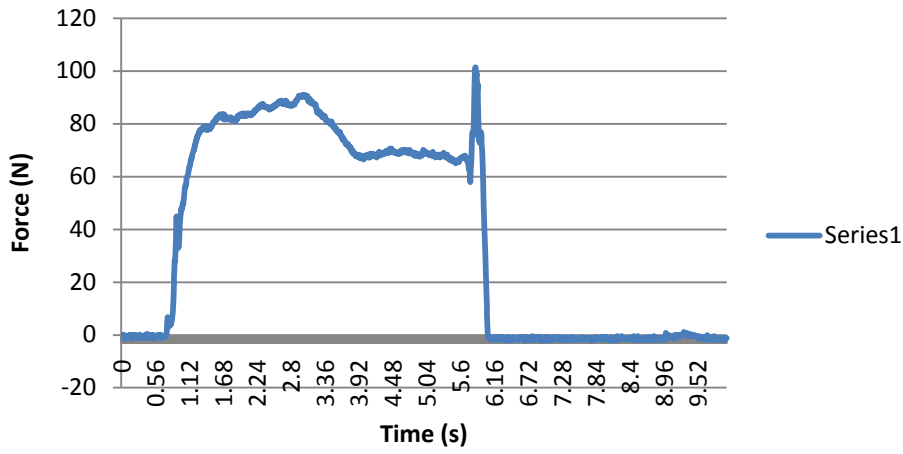

Alt 3 Vertical Linear Average Mx

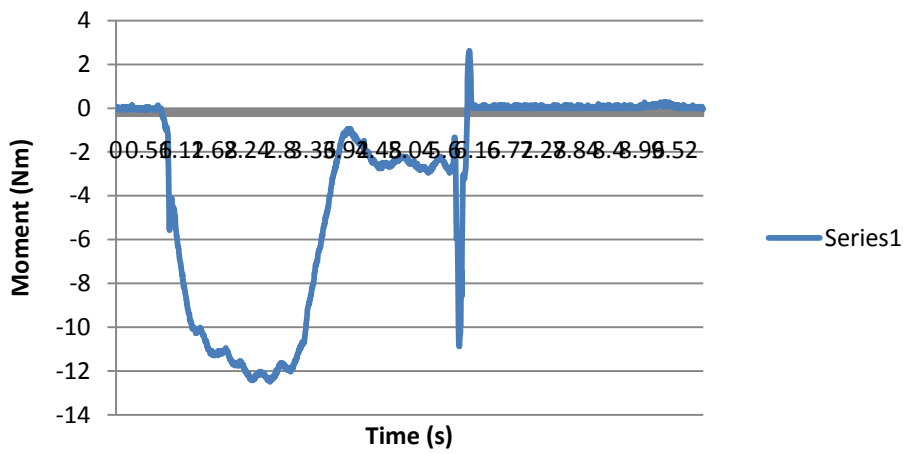

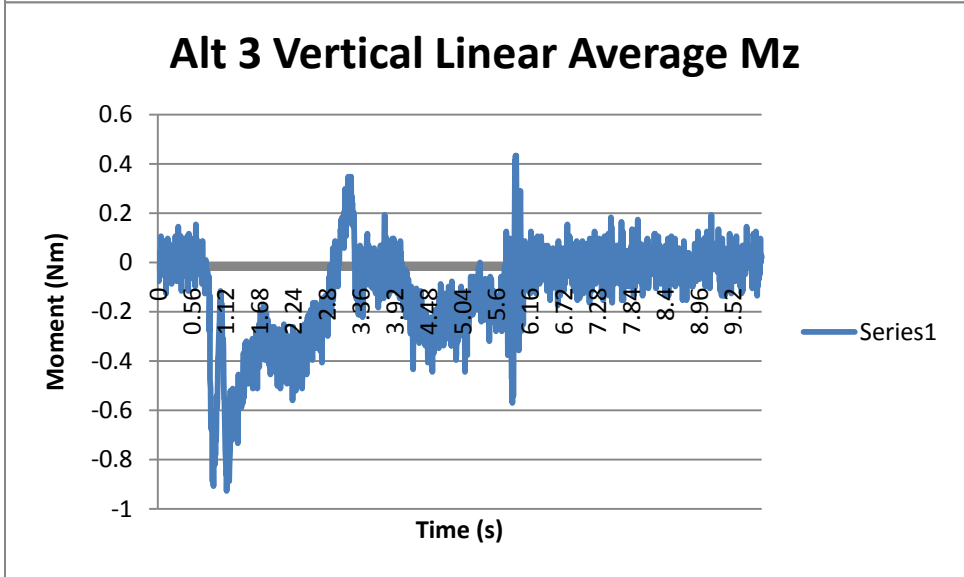
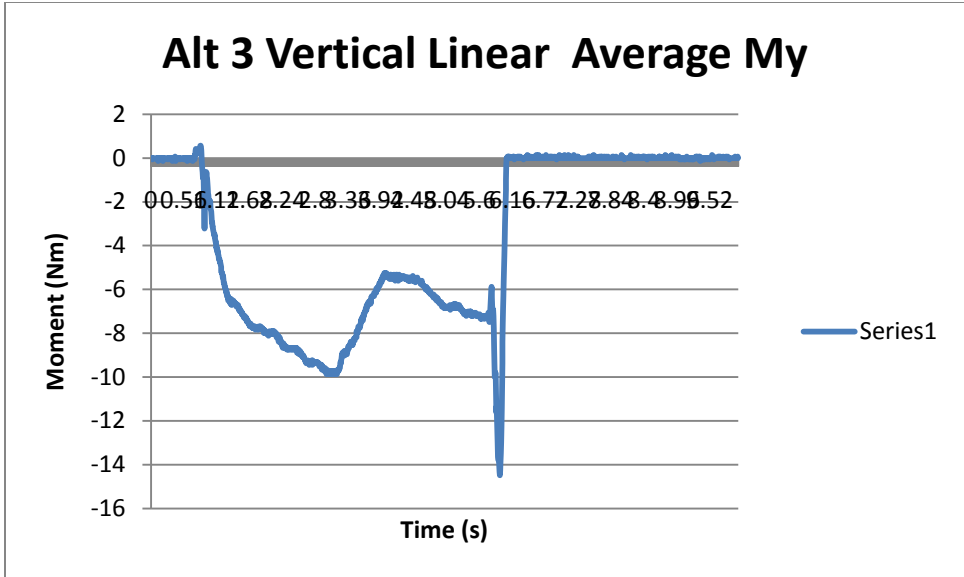

Alternative 4

Alt 4 Circ CCW Fx

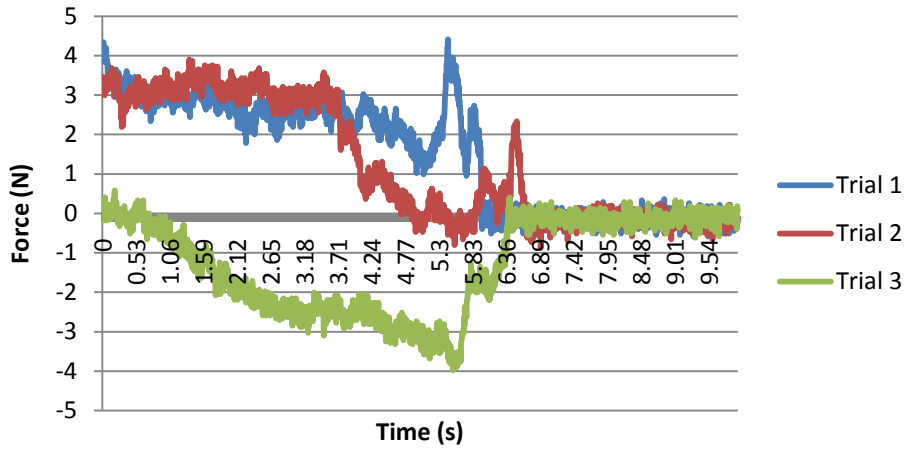

Alt 4 Circ CCW Fy

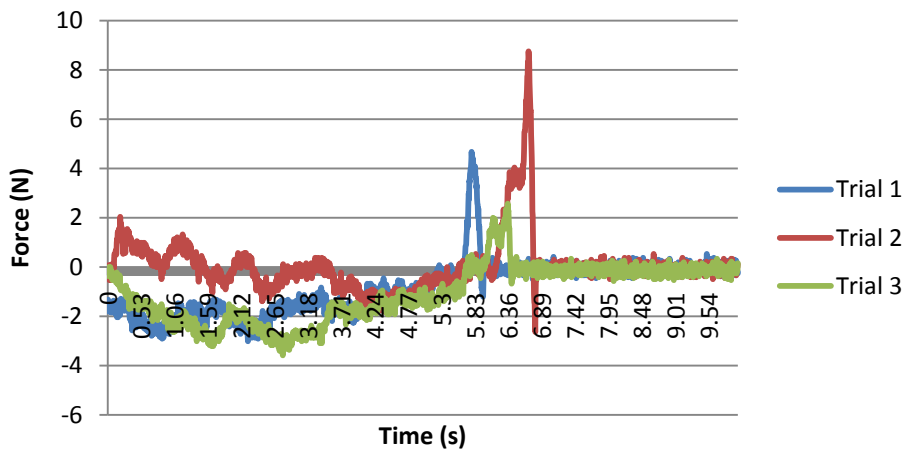

Alt 4 Circ CCW Fz

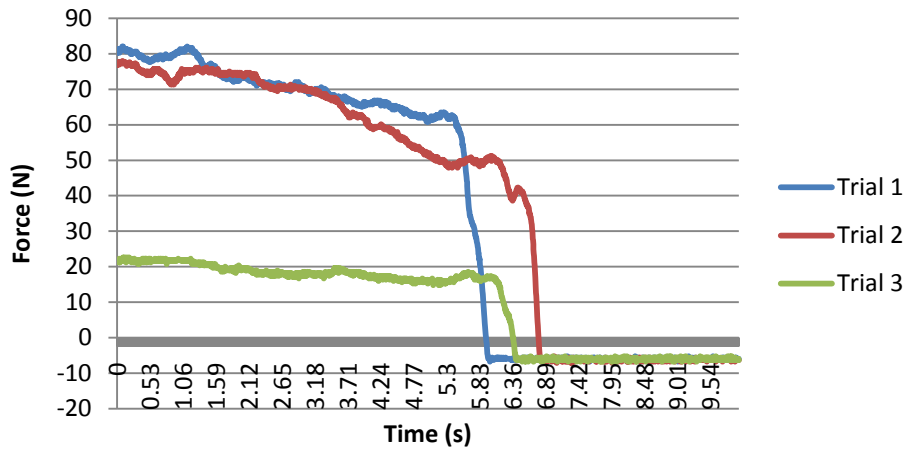

Alt 4 Circ CCW Mx

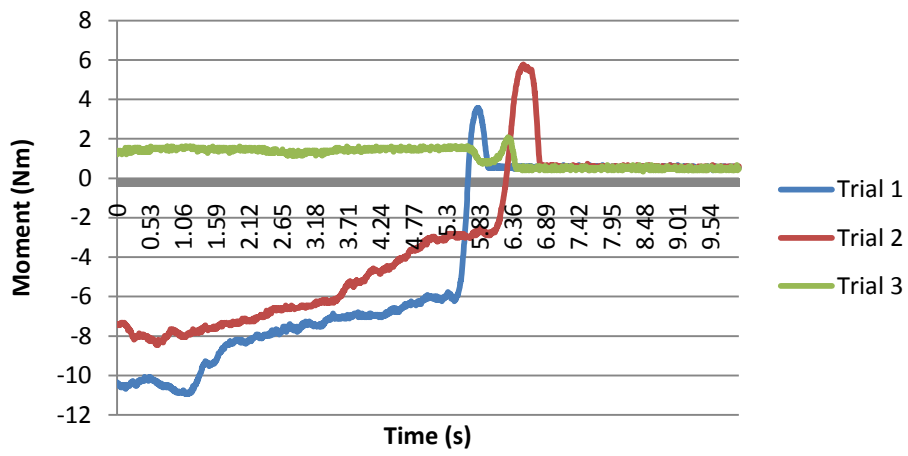

Alt 4 Circ CCW My

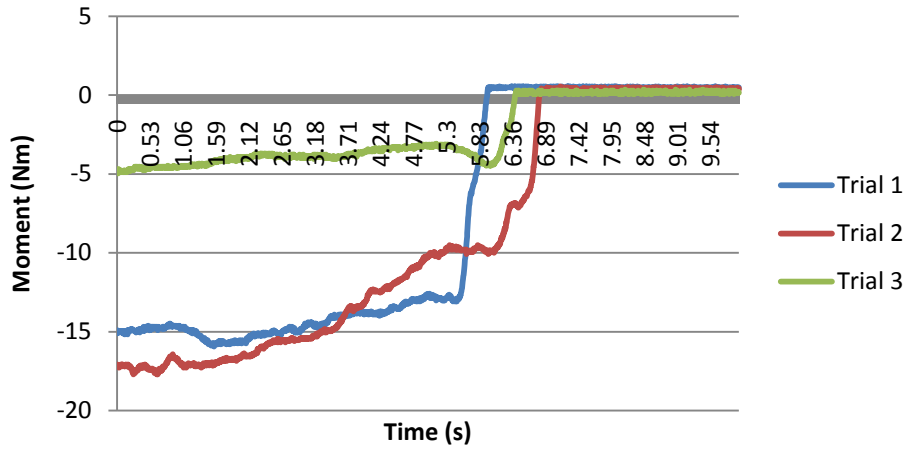

Alt 4 Circ CCW Mz

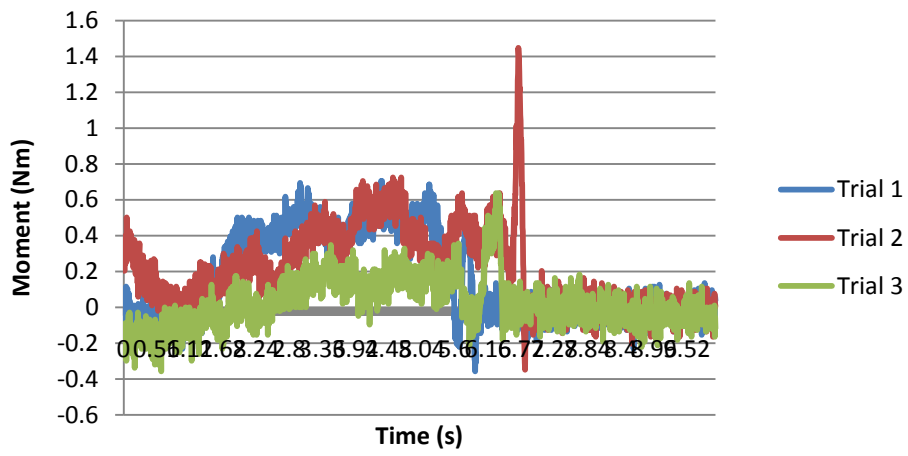

Alt 4 Circ CCW Average Fx

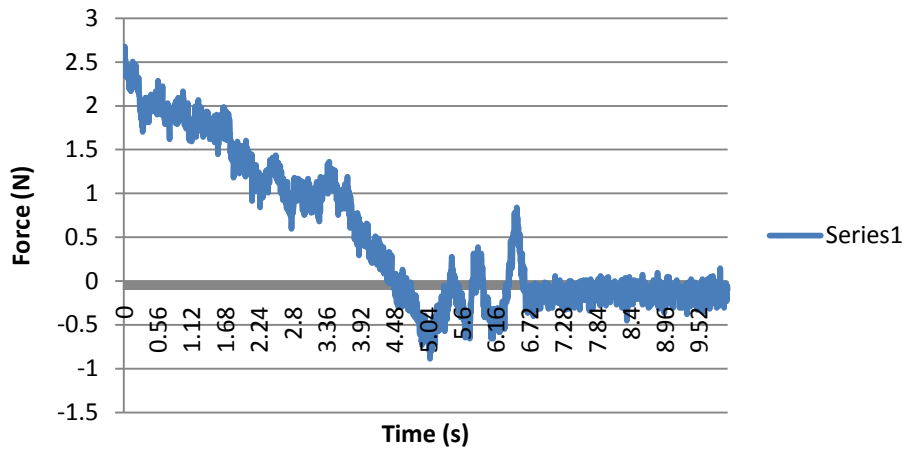

Alt 4 Circ CCW Average Fy

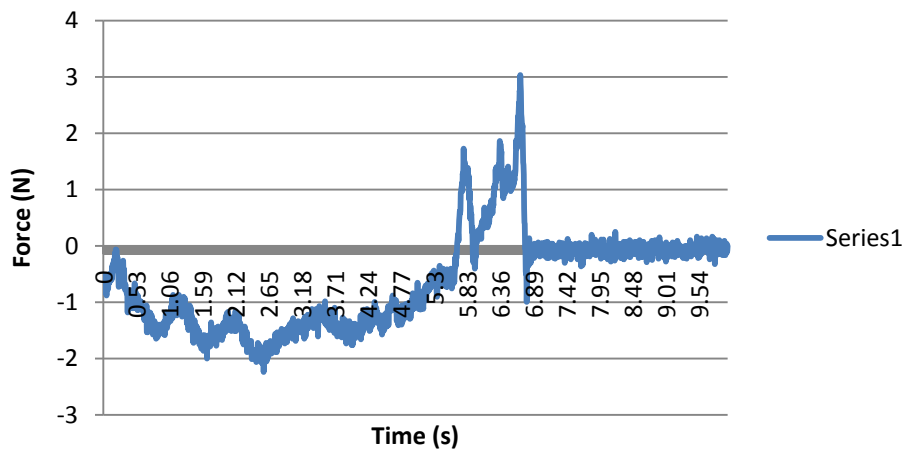

Alt 4 Circ CCW Average Fz

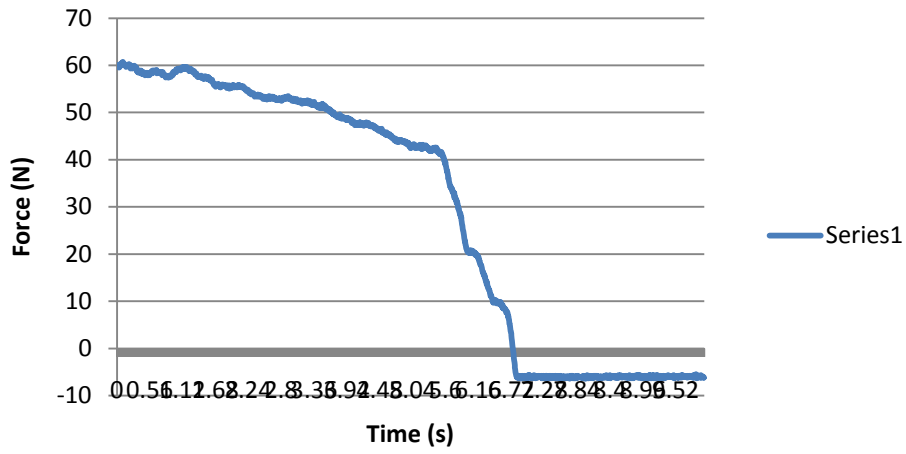

Alt 4 Circ CCW Average Mx

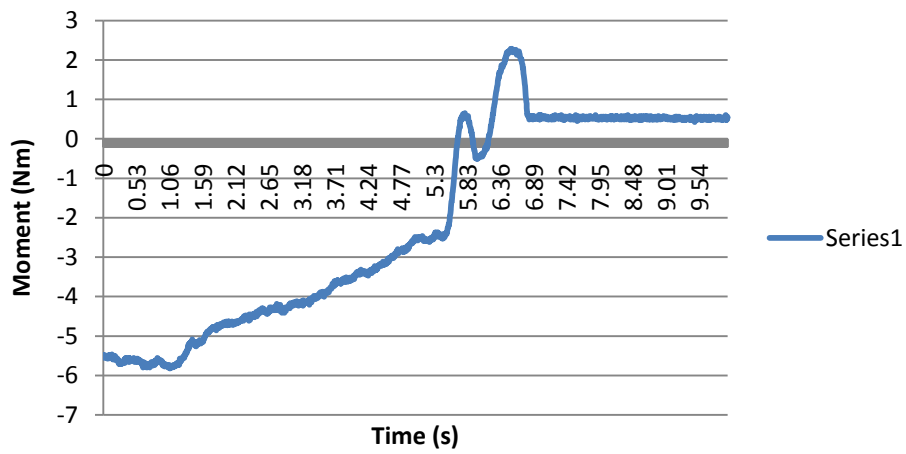

Alt 4 Circ CCW Average My

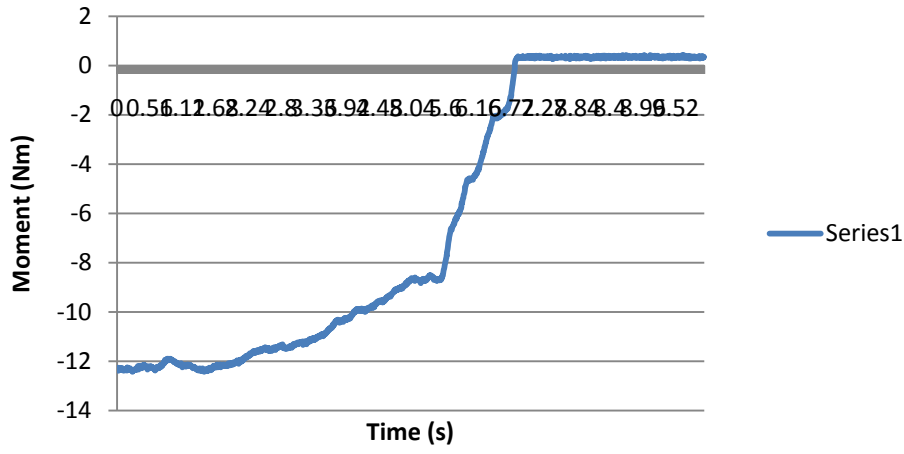

Alt 4 Circ CCW Average Mz

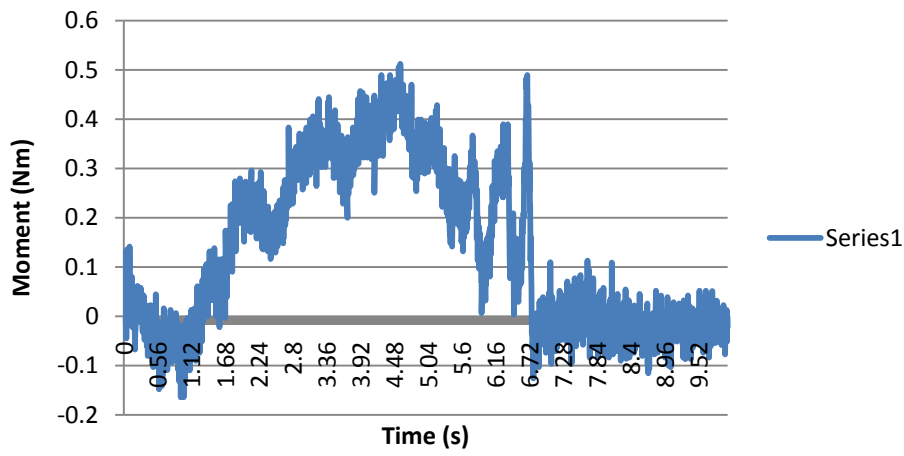

Alt 4 Circ CW Fx

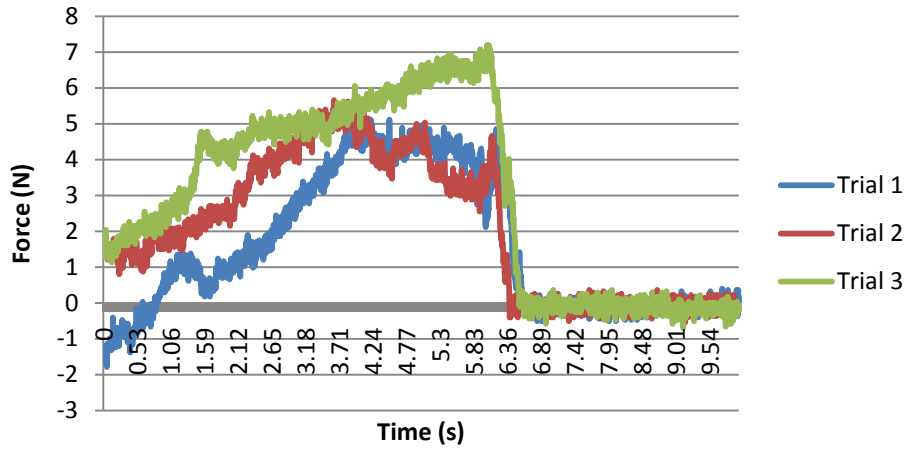

Alt 4 Circ CW Fy

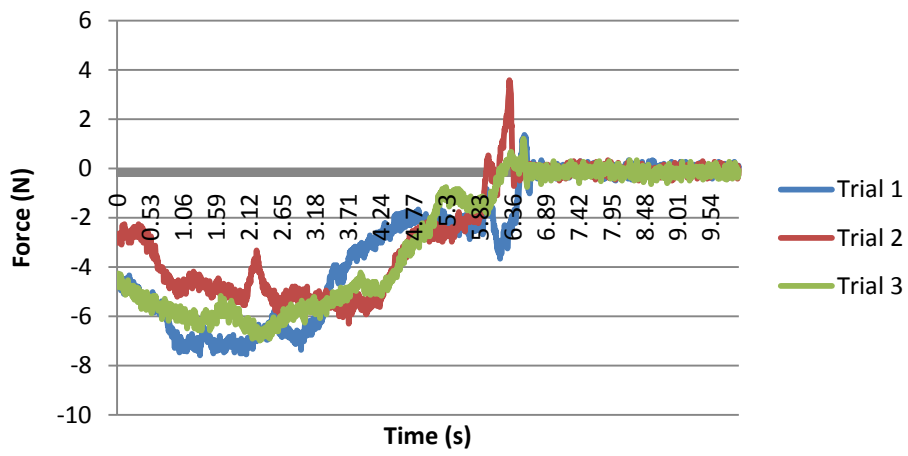

Alt 4 Circ CW Fz

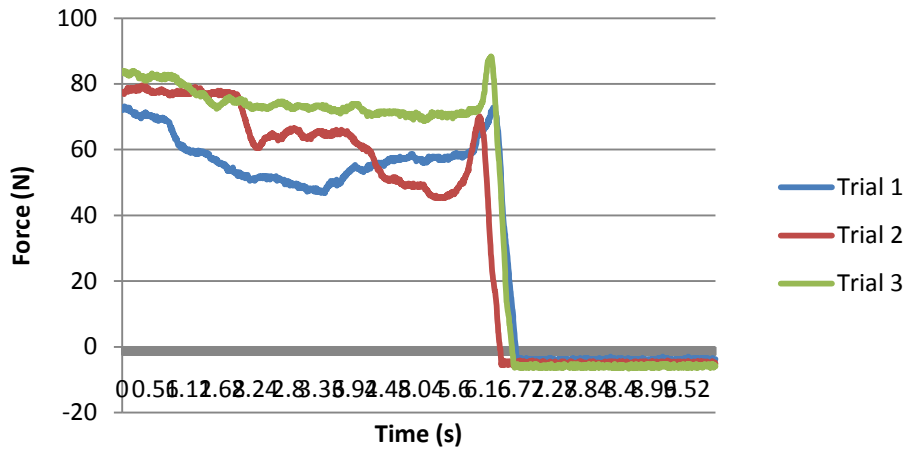

Alt 4 Circ CW Mx

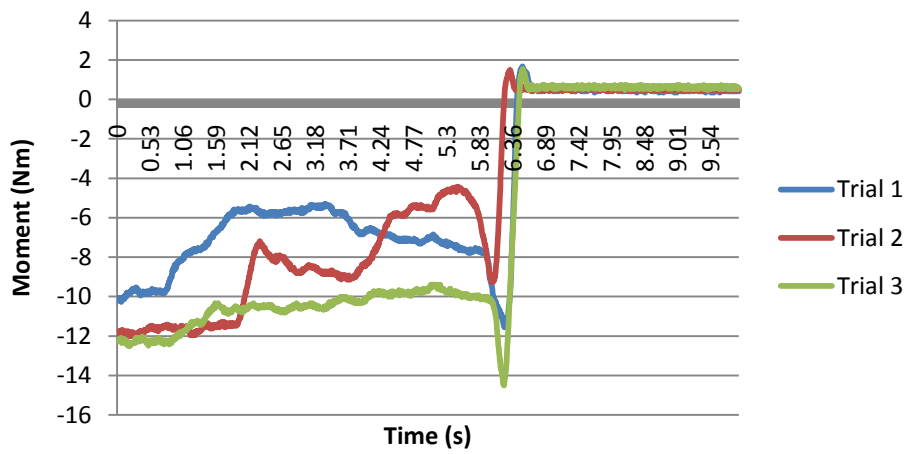

Alt 4 Circ CW My

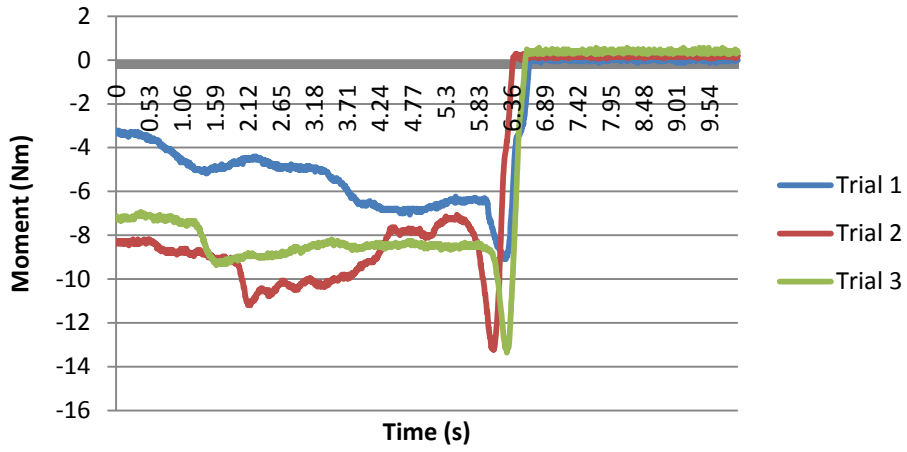

Alt 4 Circ CW Mz

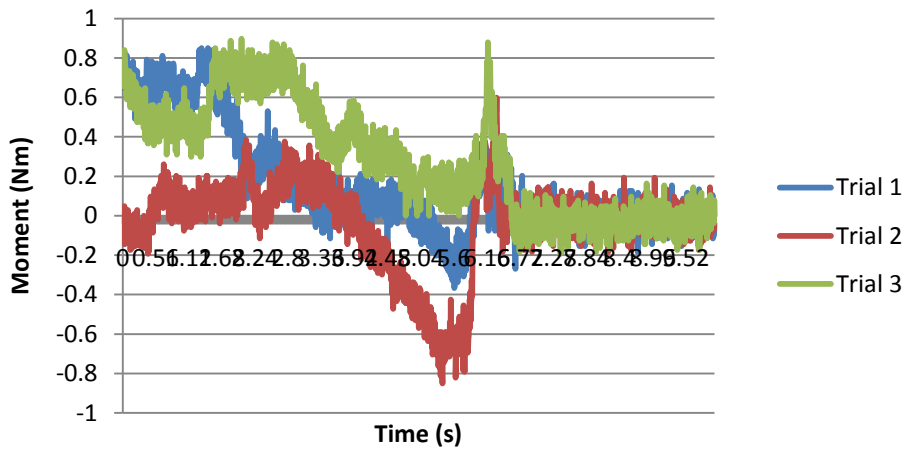

Alt 4 Circ CW Average Fx

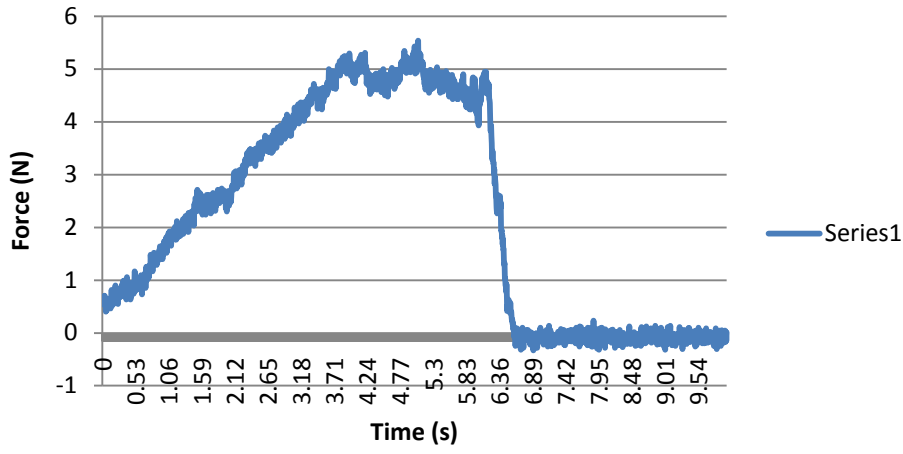

Alt 4 Circ CW Average Fy

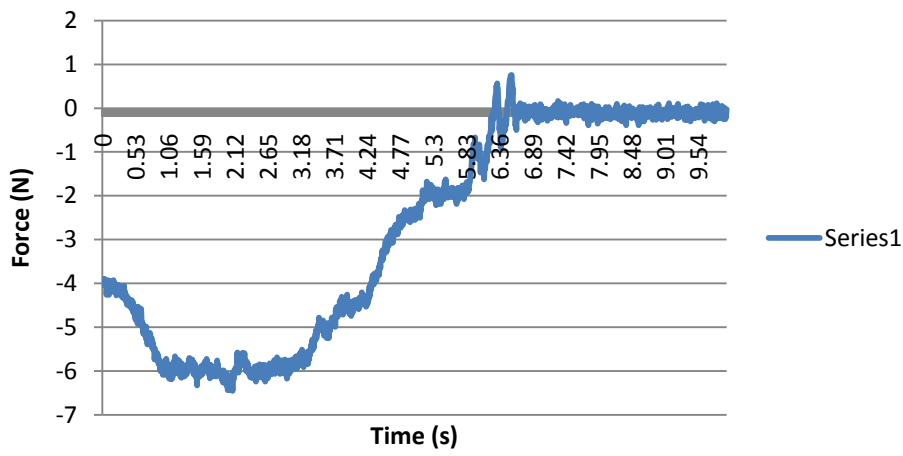

Alt 4 Circ CW Average Fz

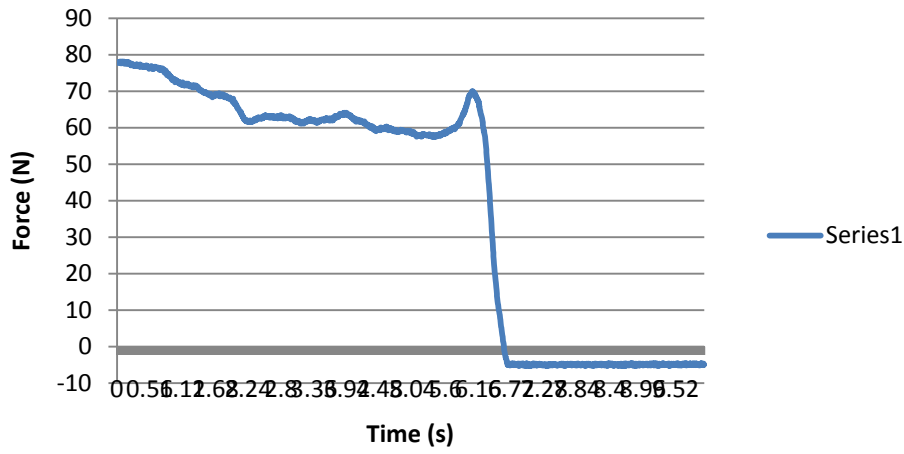

Alt 4 Circ CW Average Mx

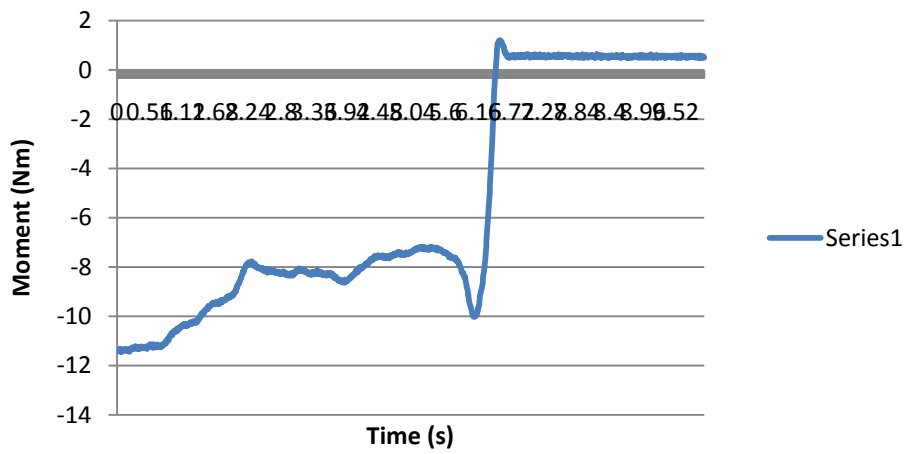

Alt 4 Circ CW Average My

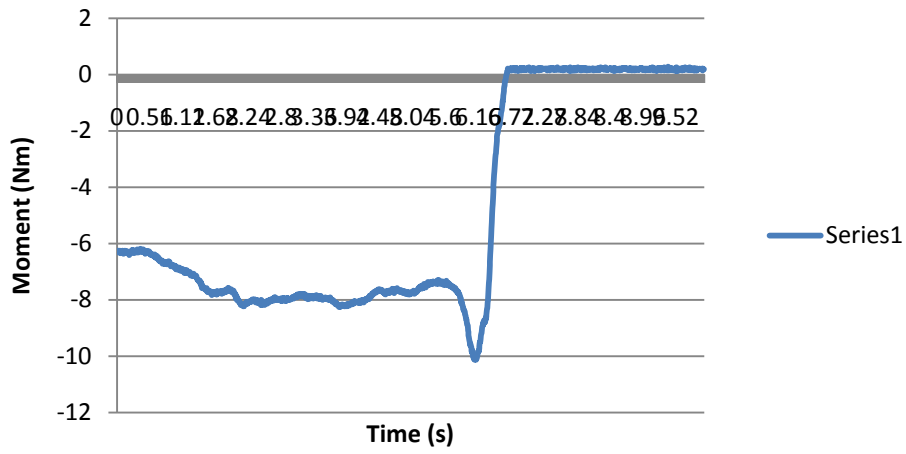

Alt 4 Circ CW Average Mz

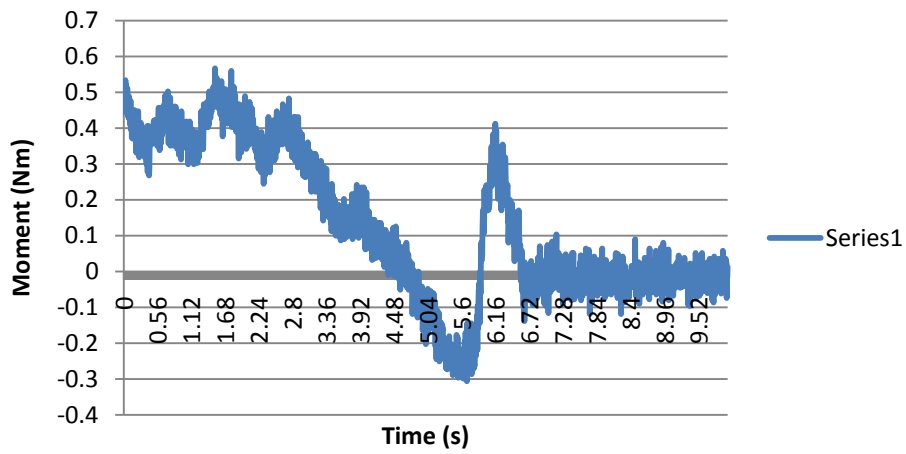

Alt 4 Circ CCW Fx

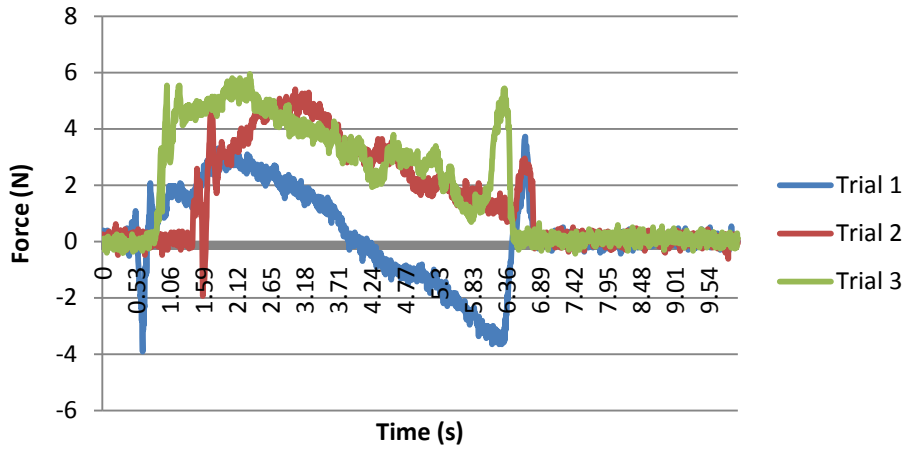

Alt 4 Circ CCW Fy

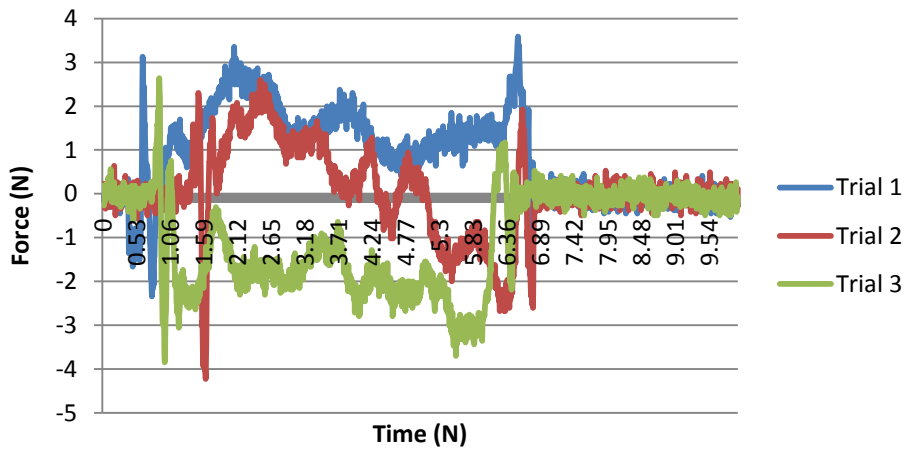

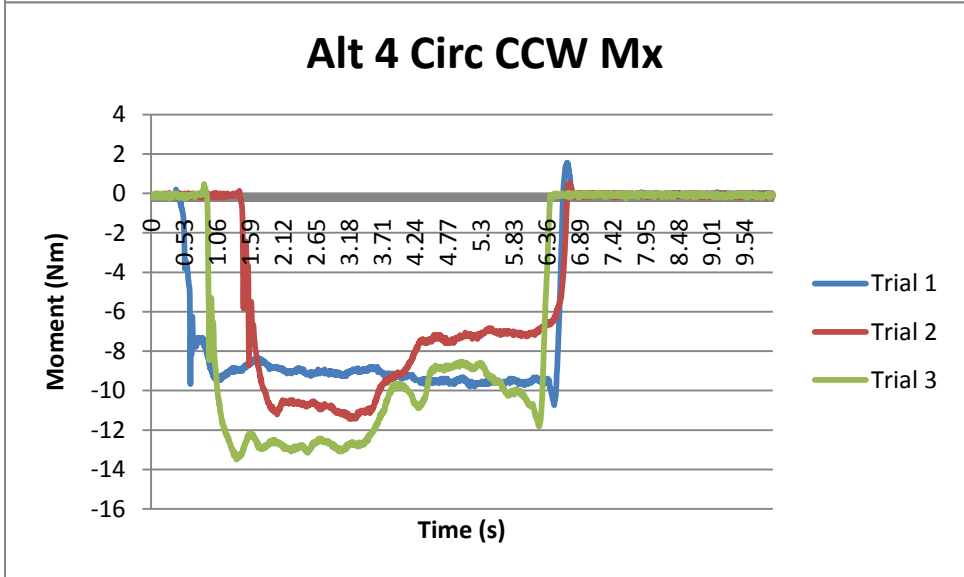
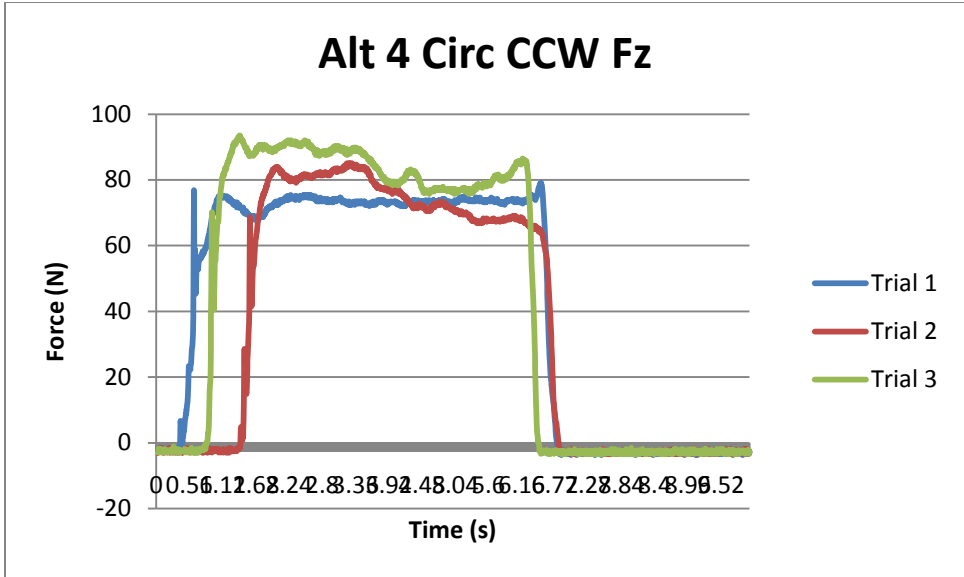

Alt 4 Circ CCW My

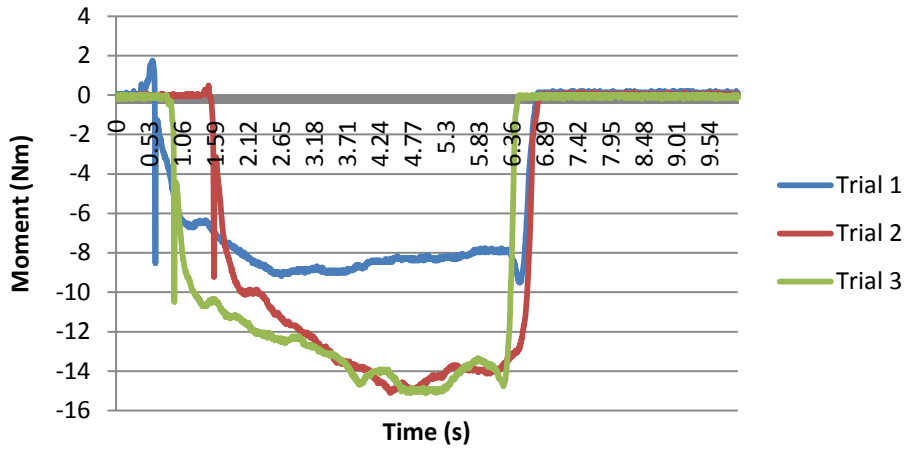

Alt 4 Circ CCW Mz

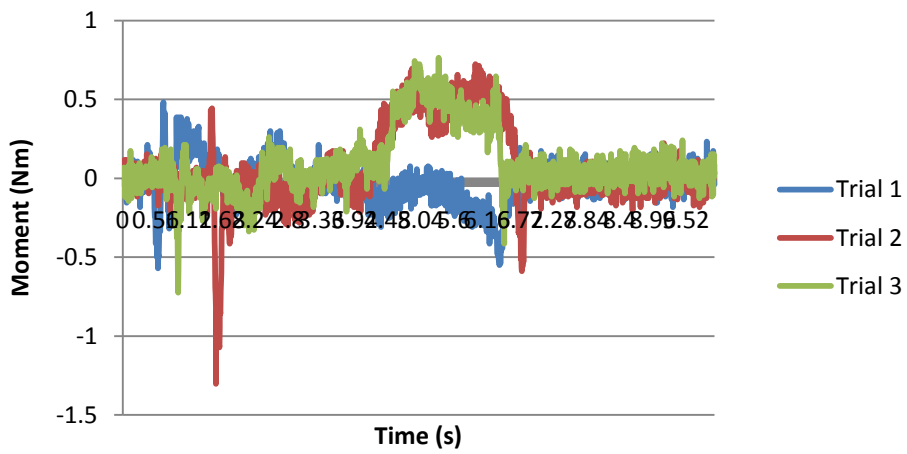

Alt 4 Circ CCW Average Fx

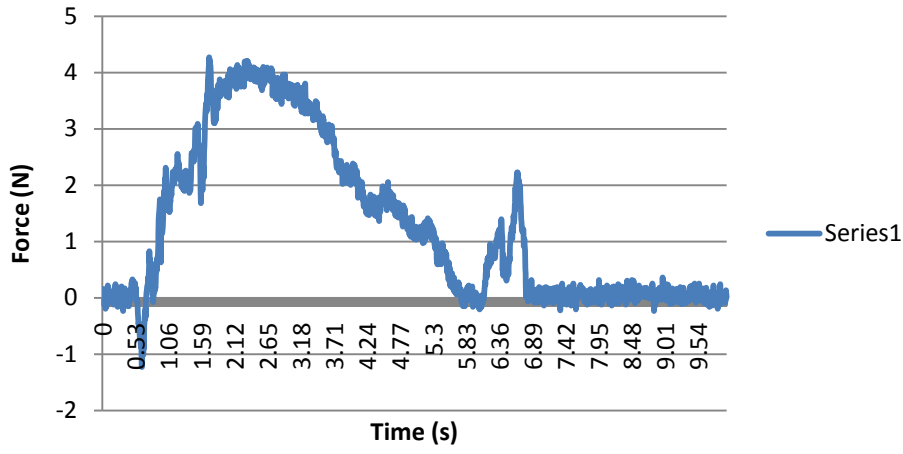

Alt 4 Circ CCW Average Fy

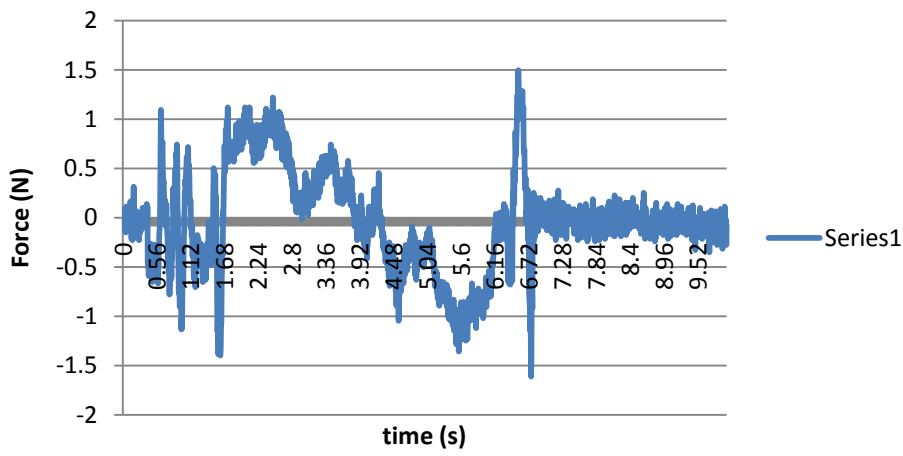

Alt 4 Circ CCW Average Fz

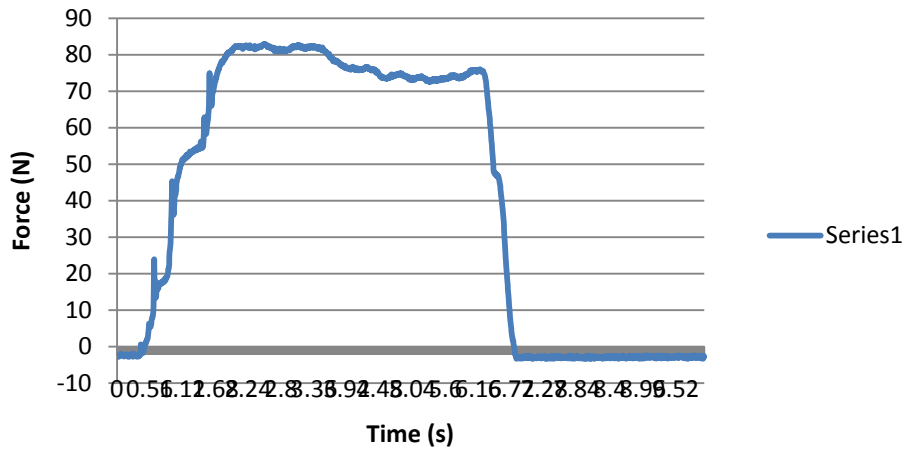

Alt 4 Circ CCW Average Mx

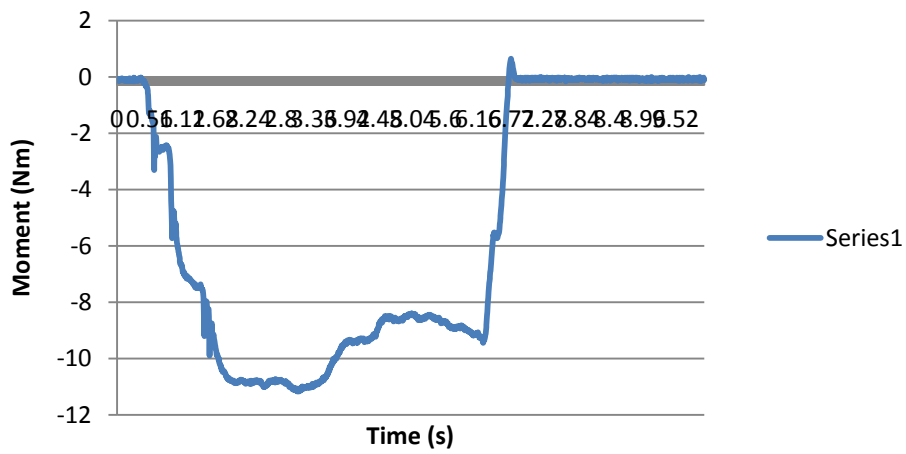

Alt 4 Circ CCW Average My

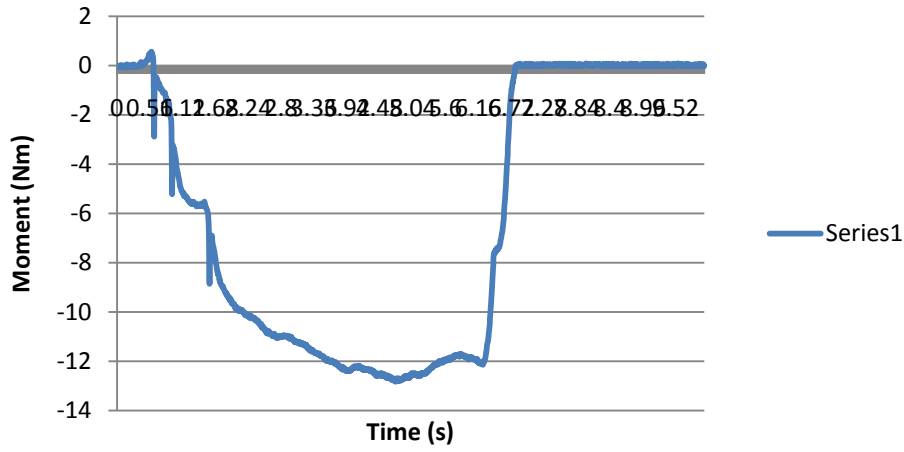

Alt 4 Circ CCW Average Mz

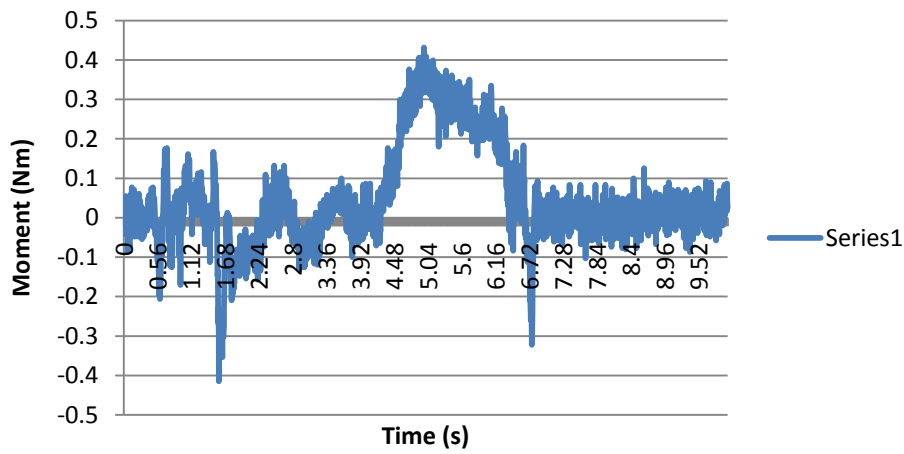

Alt 4 Elp CW Fx

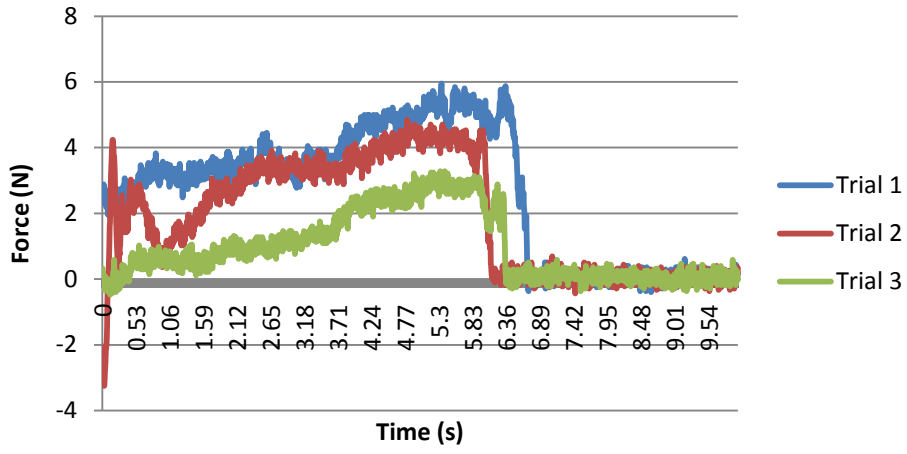

Alt 4 Elp CW Fy

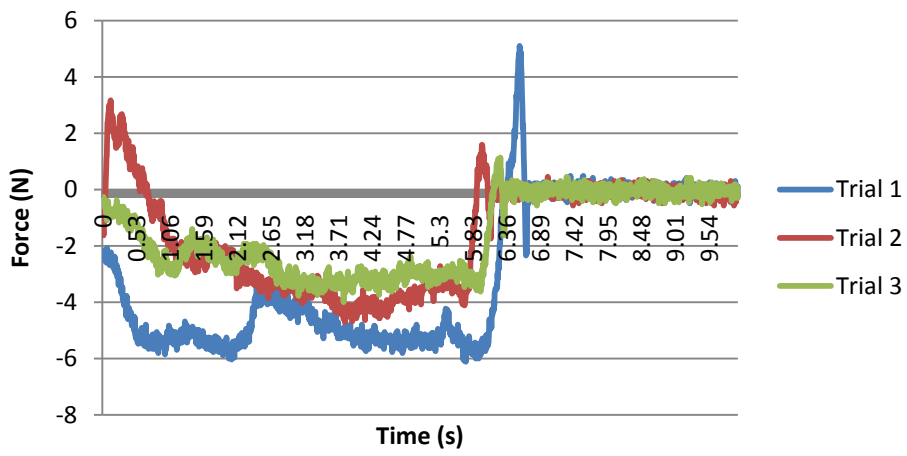

Alt 4 Elp CW Fz

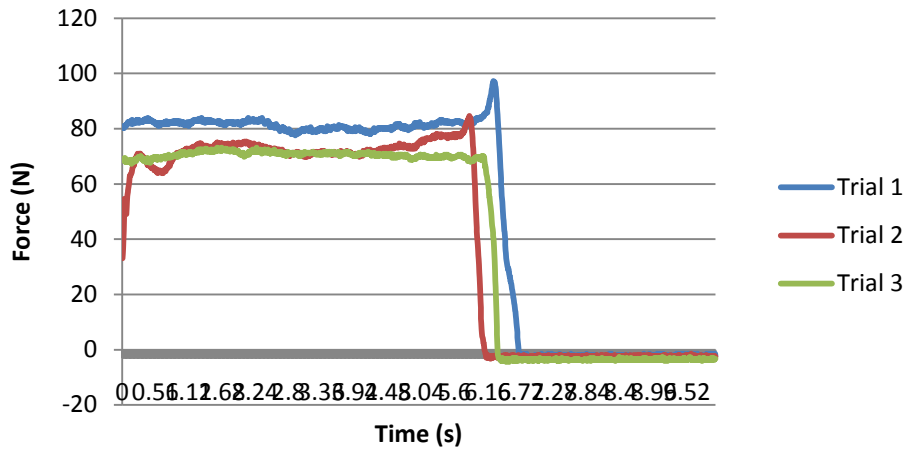

Alt 4 Elp CW Mx

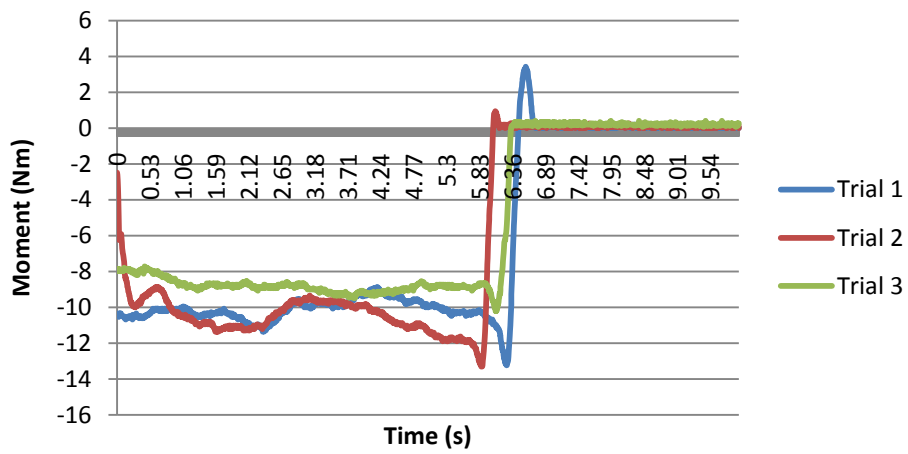

Alt 4 Elp CW My

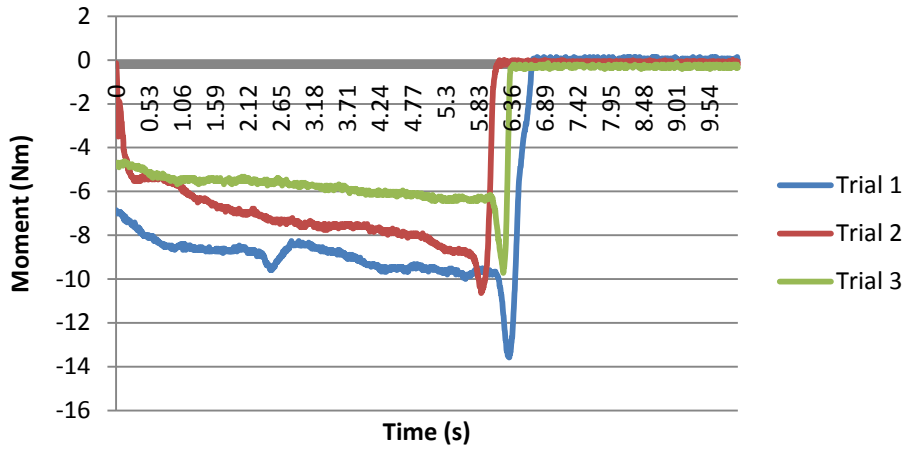

Alt 4 Elp CW Mz

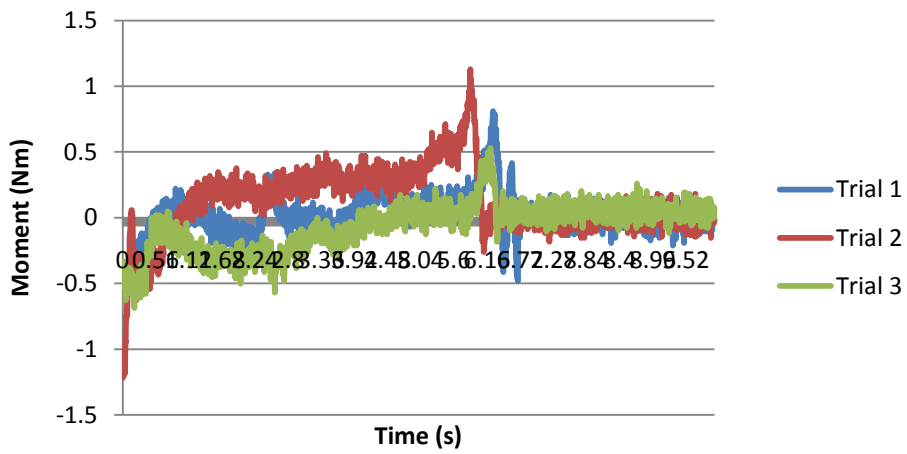

Alt 4 Elp CW Average Fx

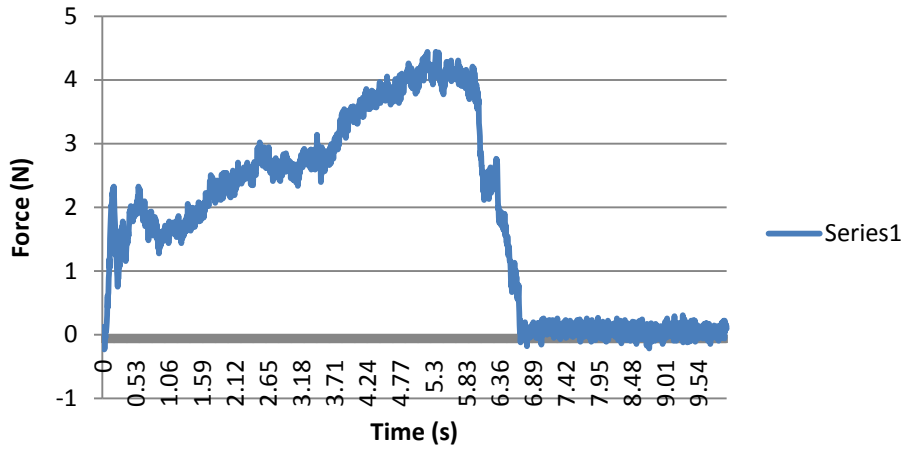

Alt 4 Elp CW Average Fy

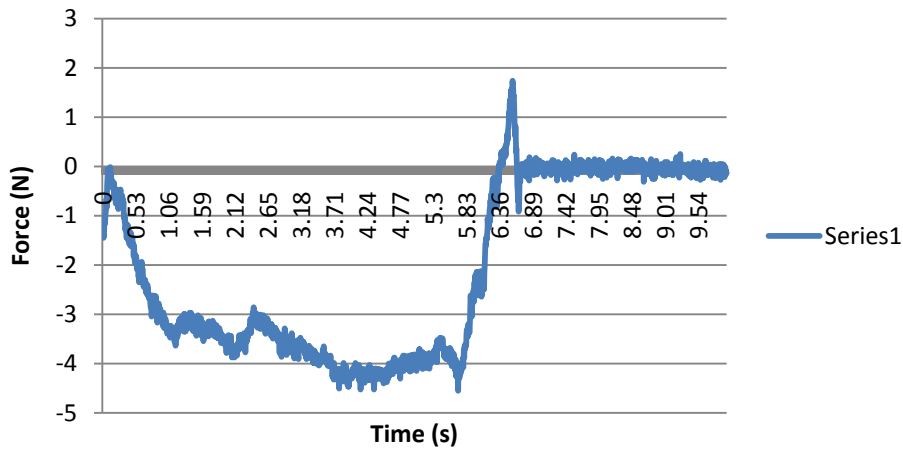

Alt 4 Elp CW Average Fz

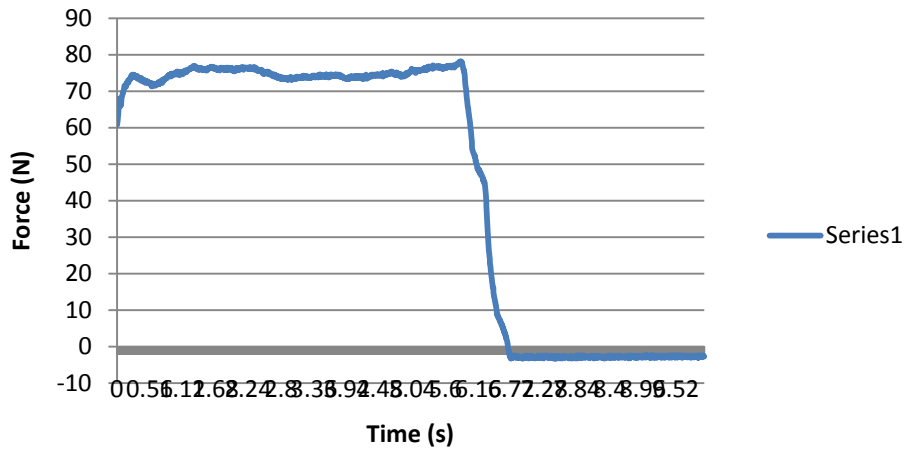

Alt 4 Elp CW Average Mx

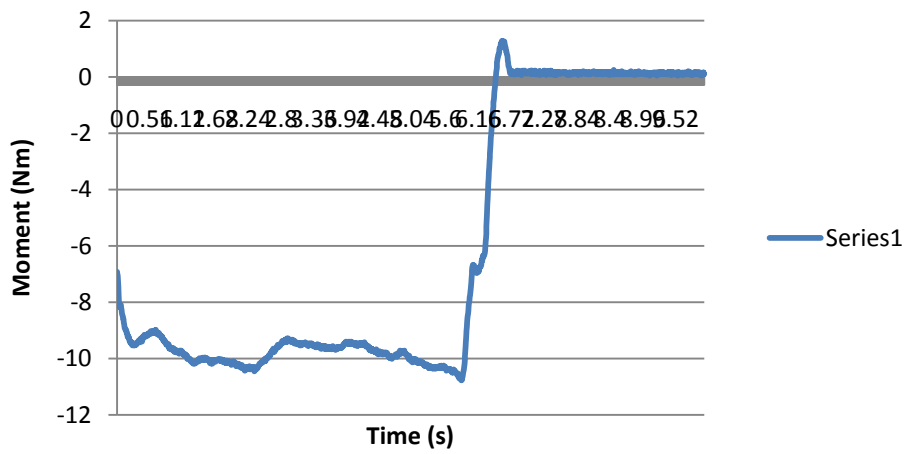

Alt 4 Elp CW Average My

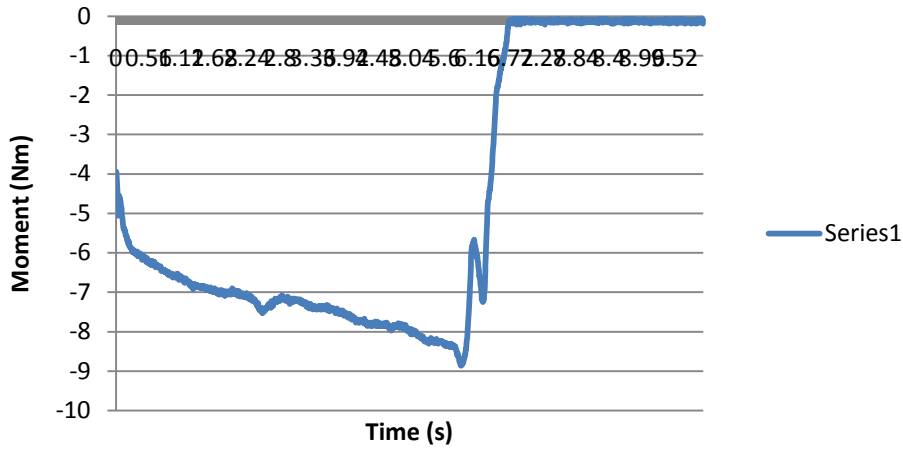

Alt 4 Elp CW Average Mz

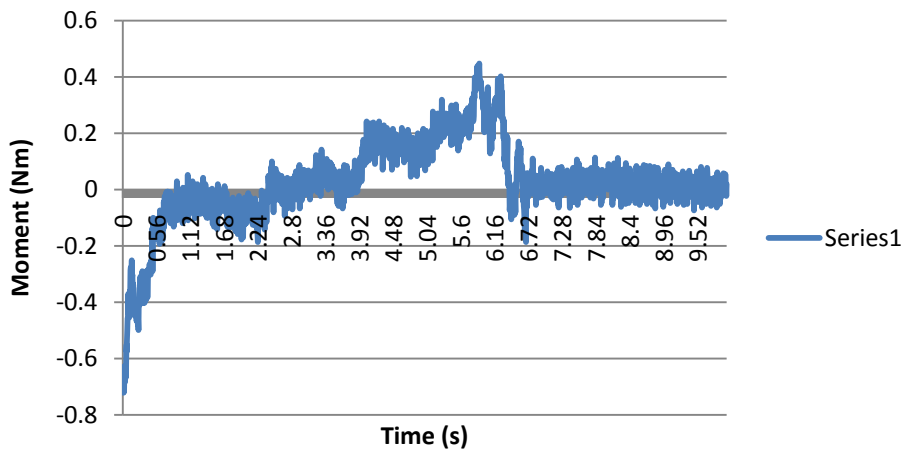

Alt 4 Horz Linear Fx

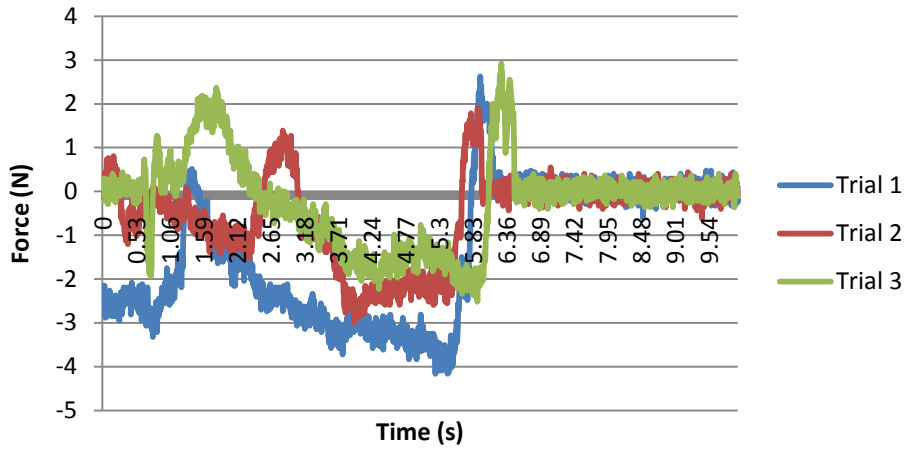

Alt 4 Horz Linear Fy

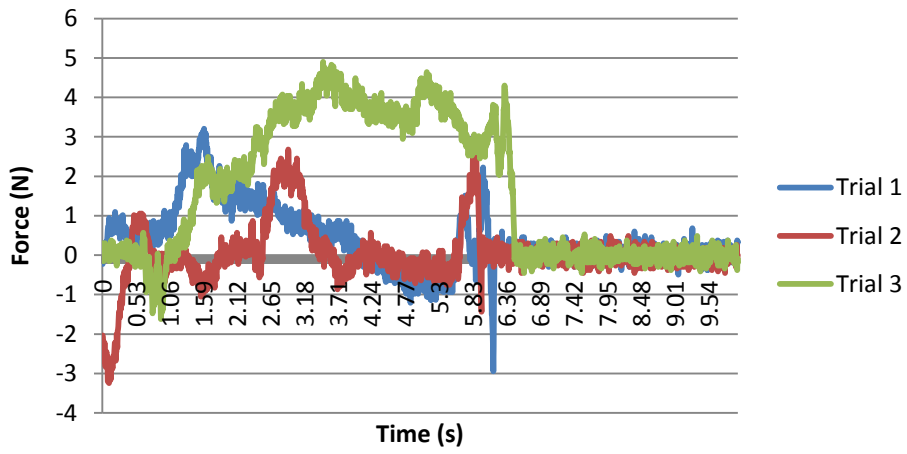

Alt 4 Horz Linear Fz

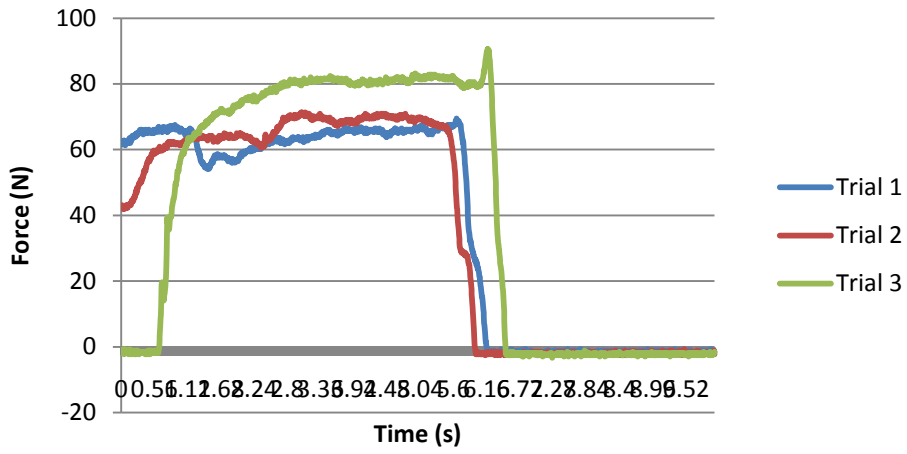

Alt 4 Horz Linear Mx

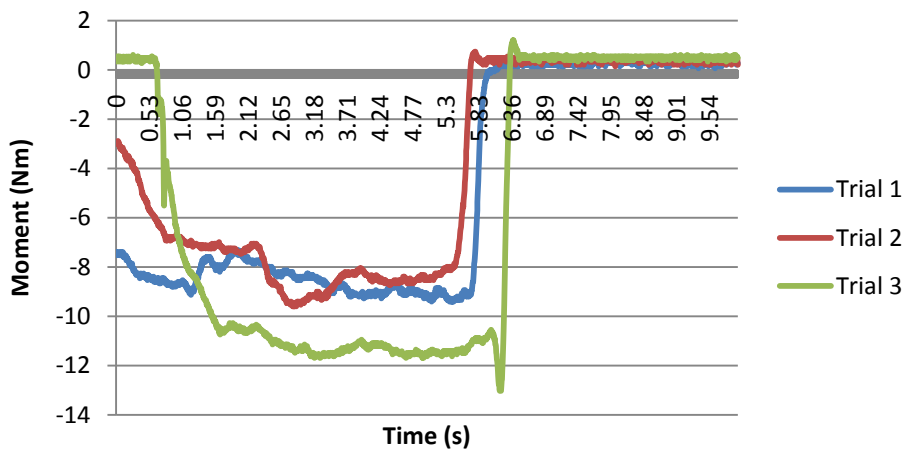

Alt 4 Horz Linear My

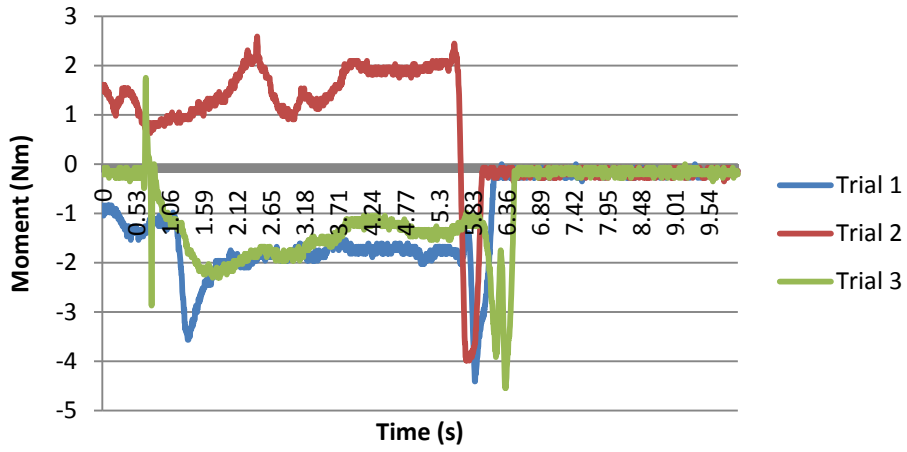

Alt 4 Horz Linear Mz

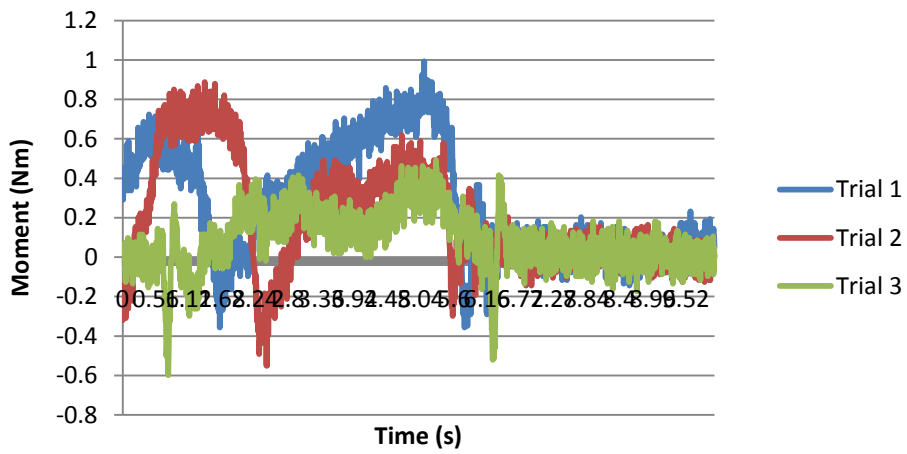

Alt 4 Horz Linear Average Fx

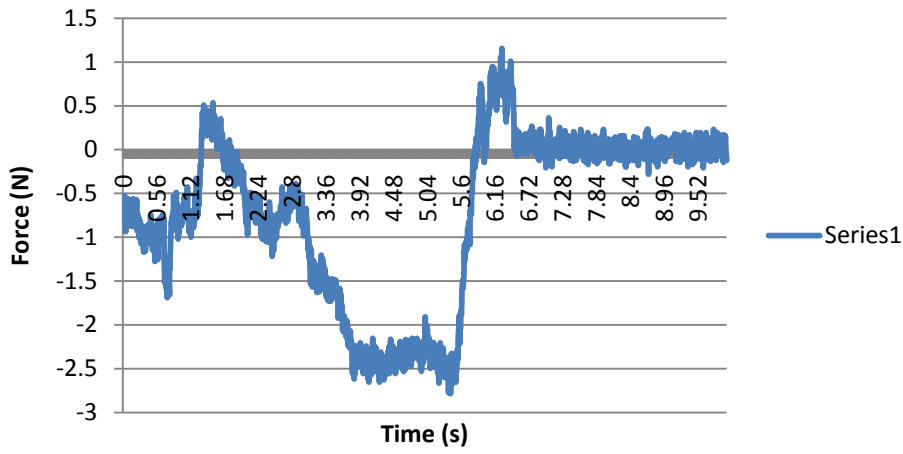

Alt 4 Horz Linear Average Fy

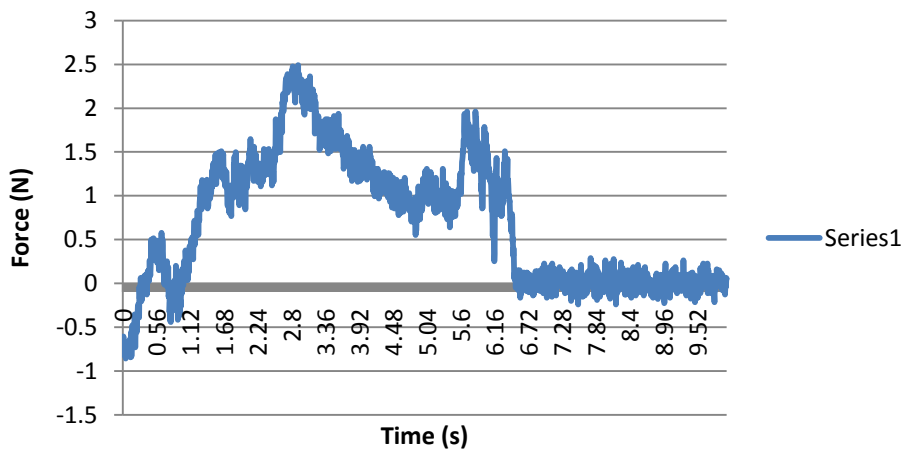

Alt 4 Horz Linear Average Fz

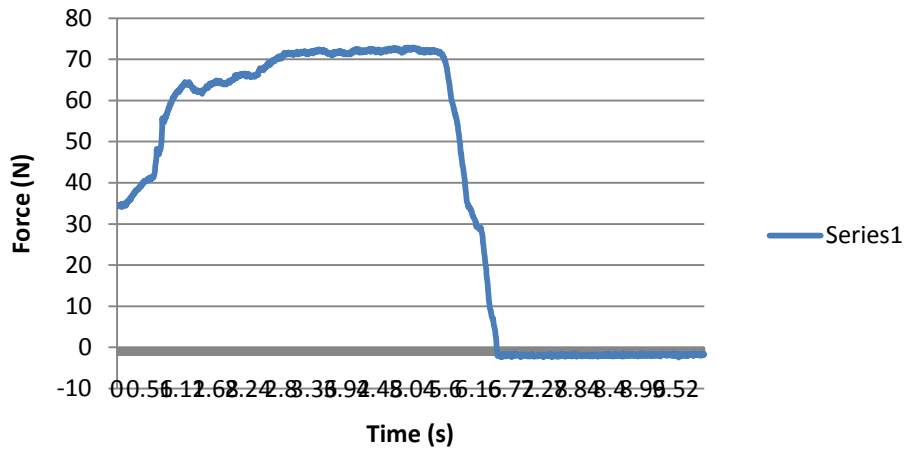

Alt 4 Horz Linear Average Mx

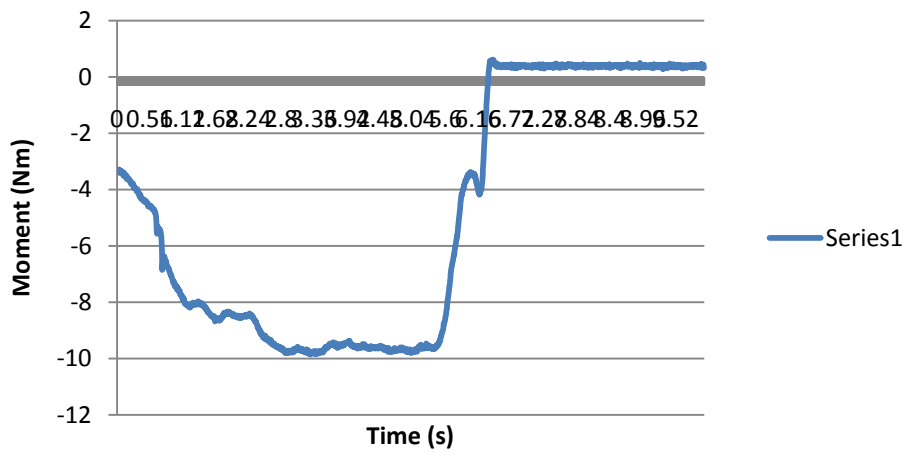

Alt 4 Horz Linear Average My

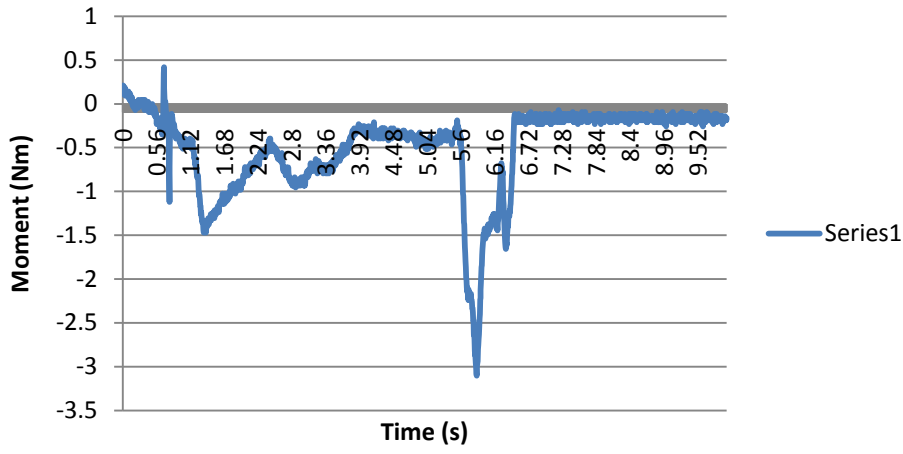

Alt 4 Horz Linear Average Mz

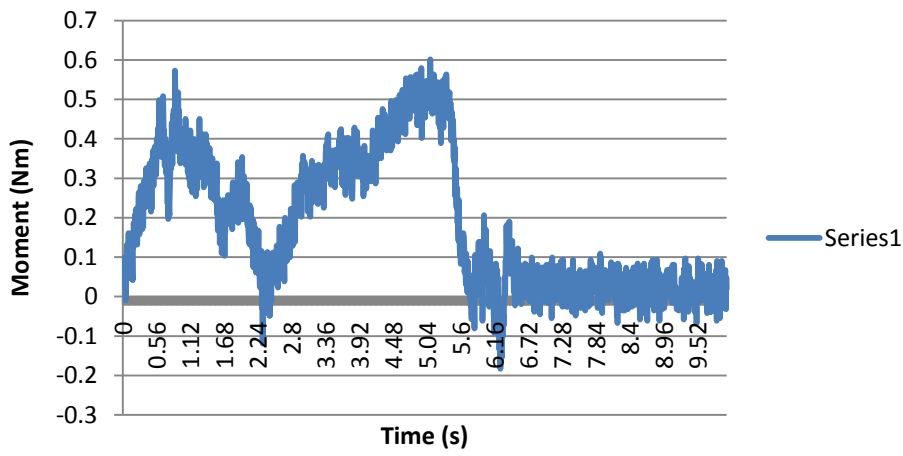

Alt 4 Vertical Linear Fx

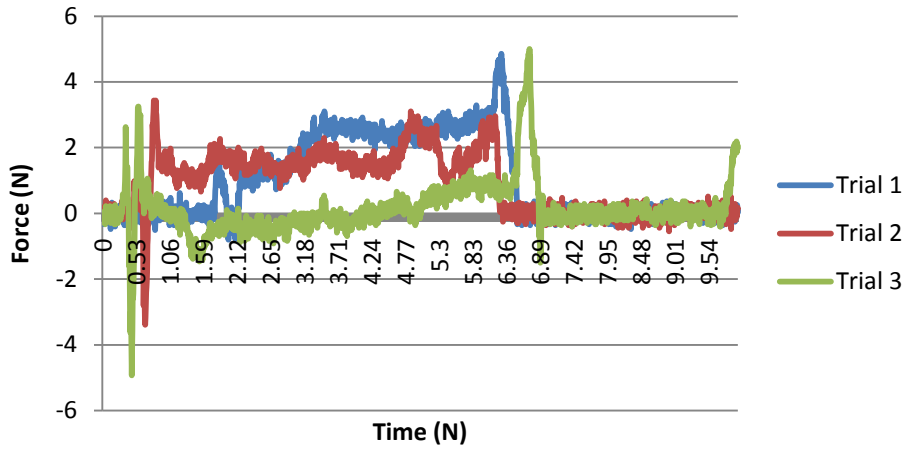

Alt 4 Vertical Linear Fy

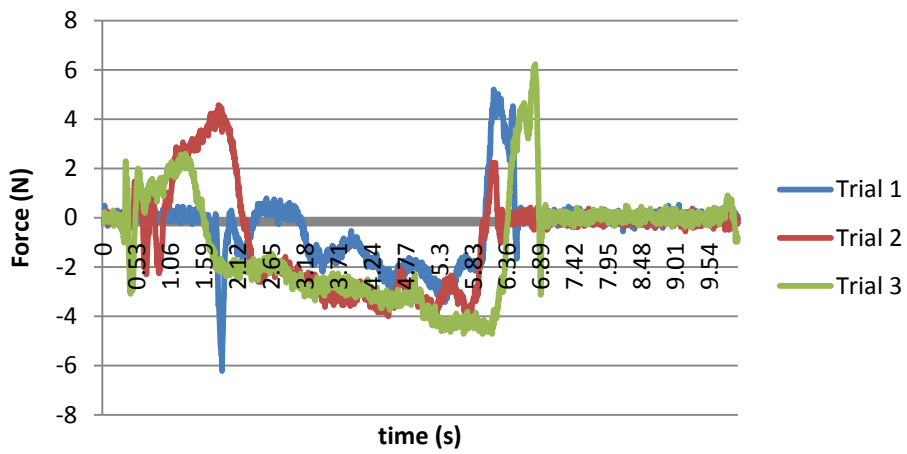

Alt 4 Vertical Linear Fz

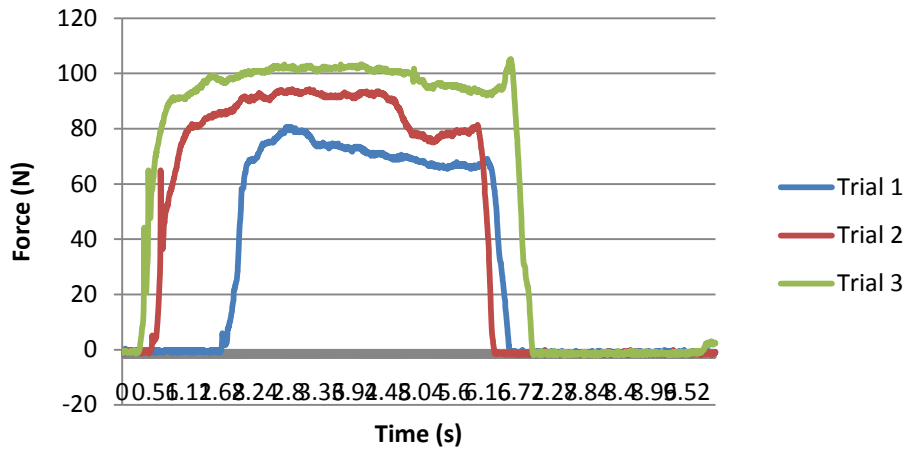

Alt 4 Vertical Linear Mx

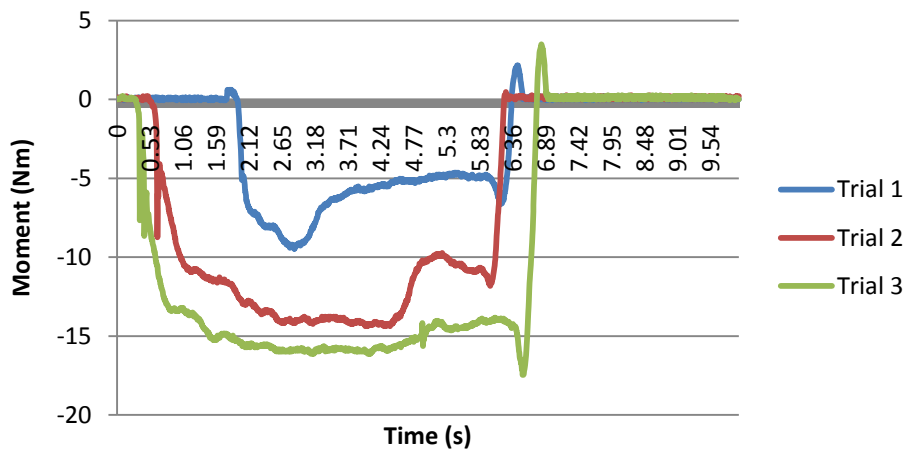

Alt 4 Vertical Linear My

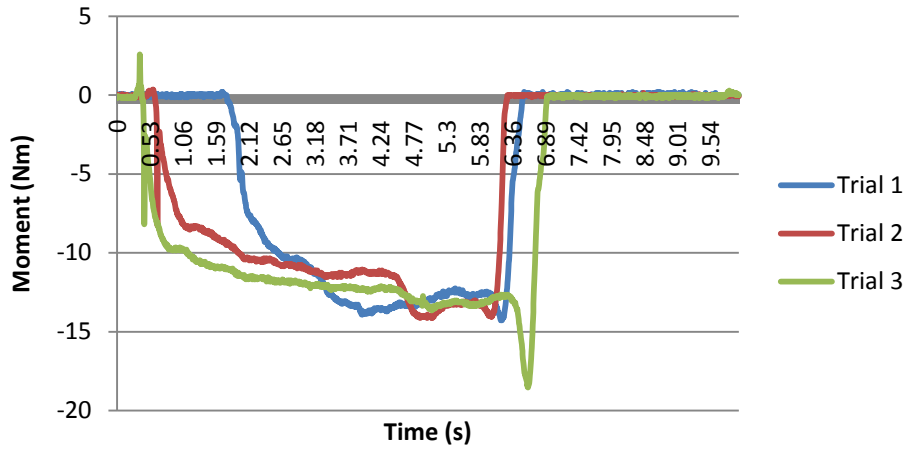

Alt 4 Vertical Linear Mz

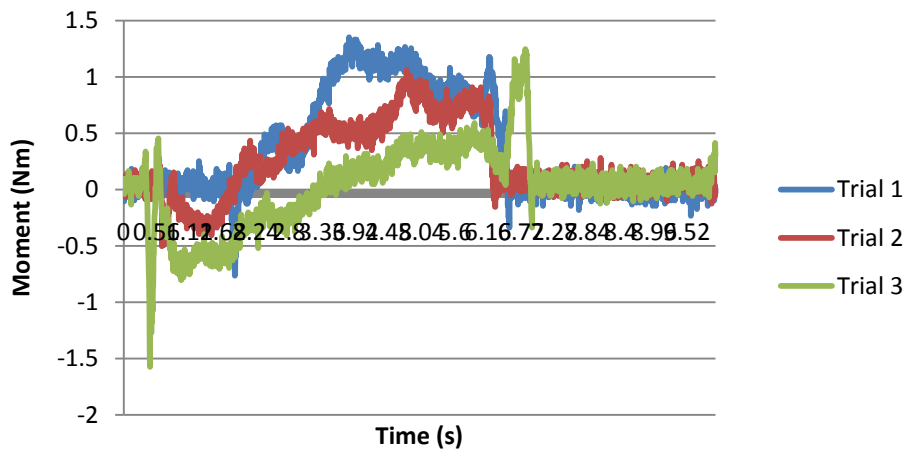

Alt 4 Vertical Linear Average Fx

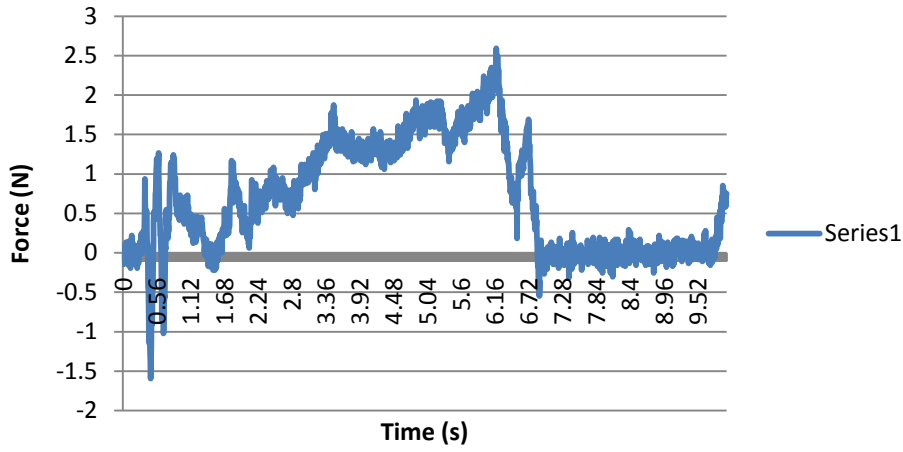

Alt 4 Vertical Linear Average Fy

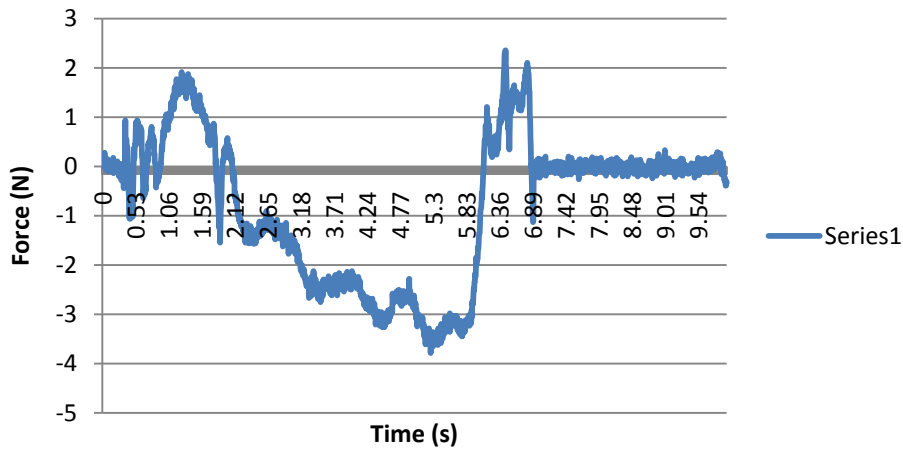

Alt 4 Vertical Linear Average Fz

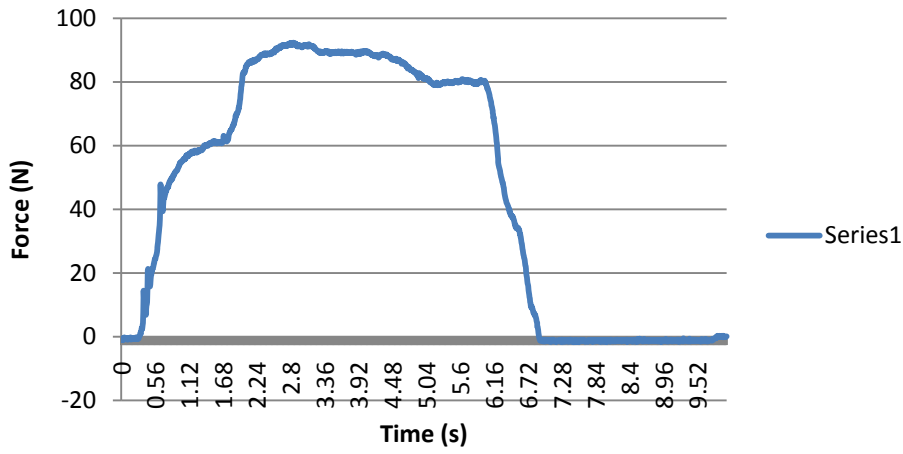

Alt 4 Vertical Linear Average Mx

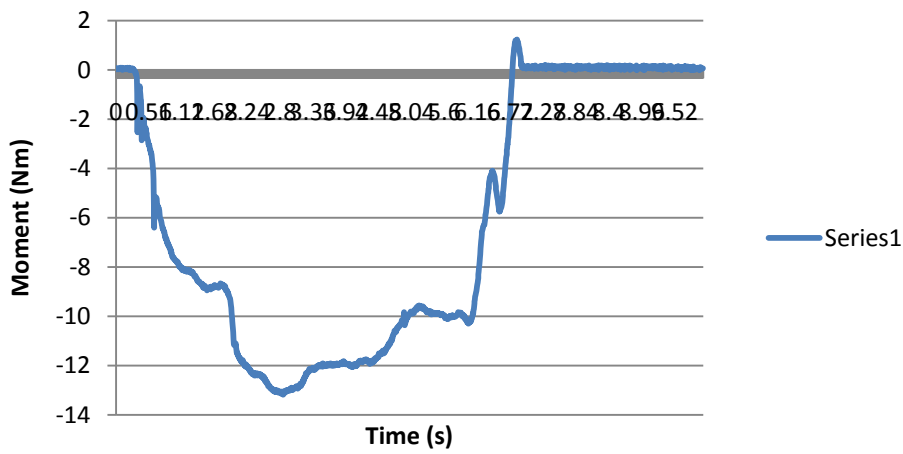

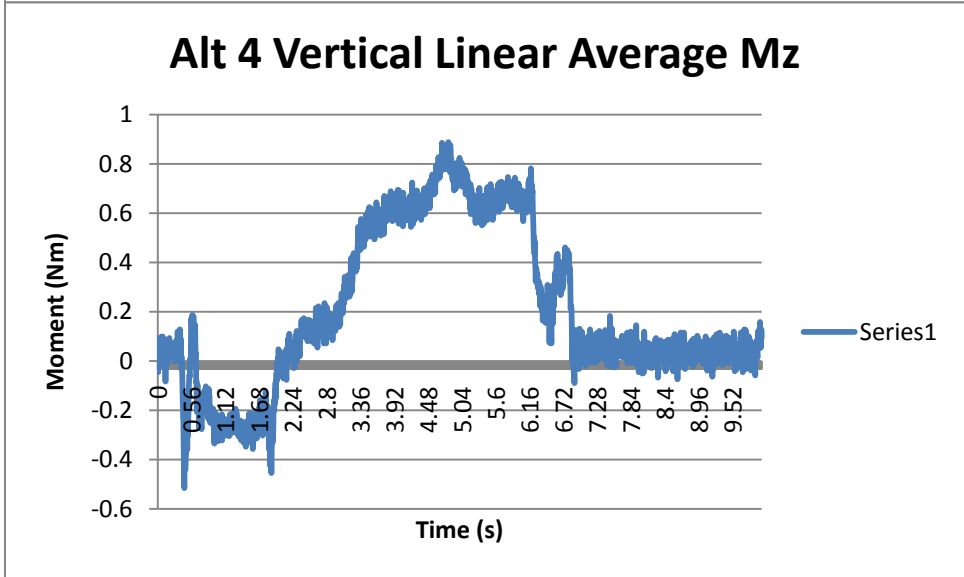
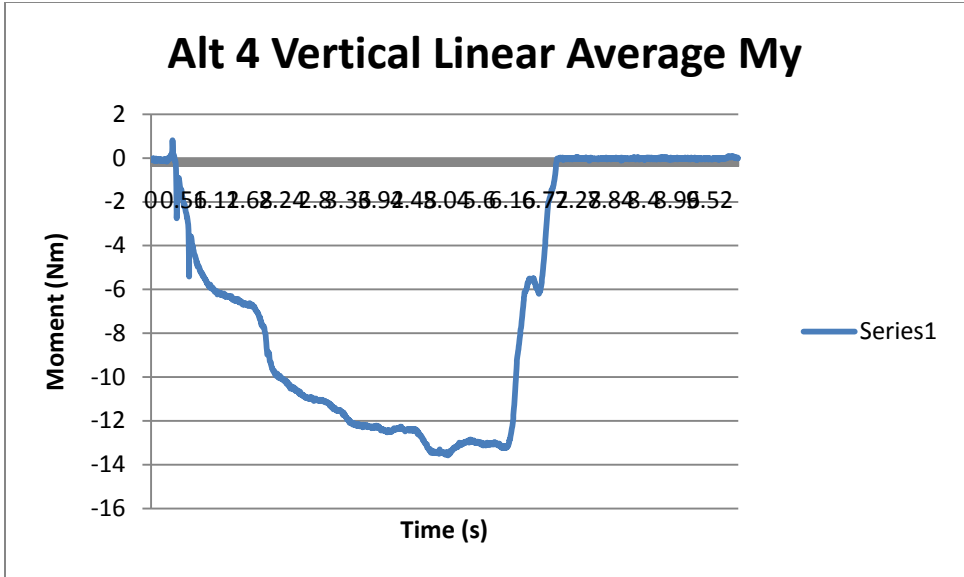

Alternative Five

Alt 5 Circ CCW Fx

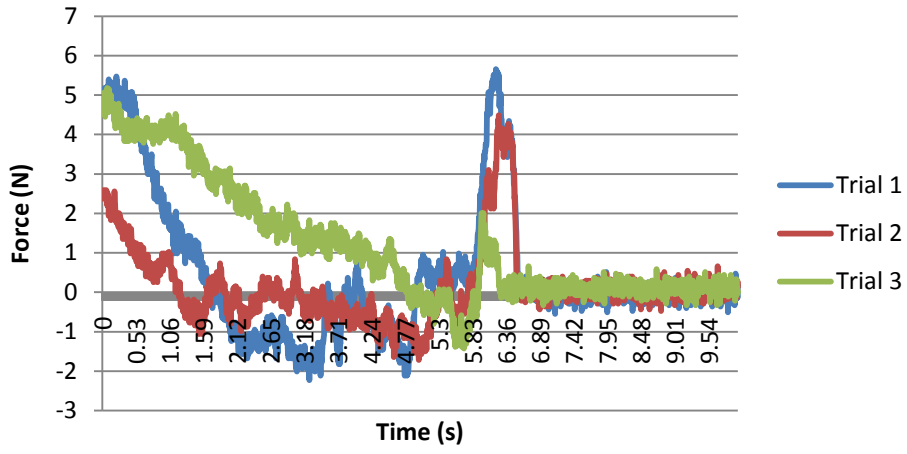

Alt 5 Circ CCW Fy

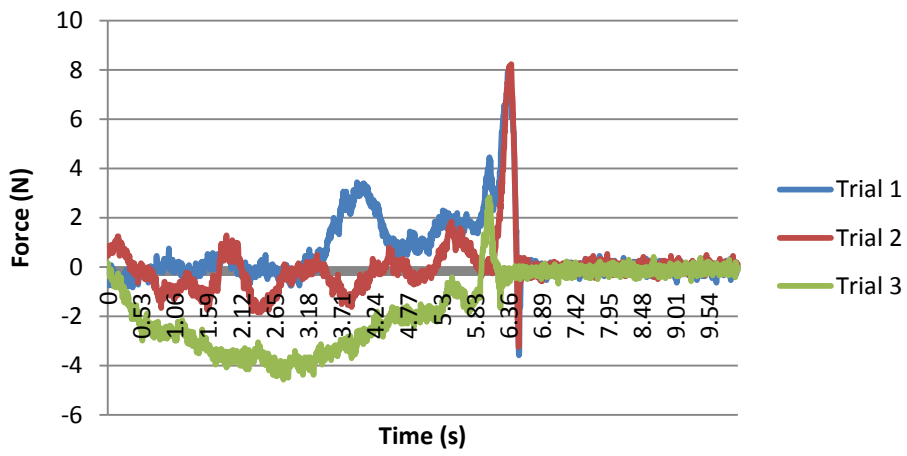

Alt 5 Circ CCW Fz

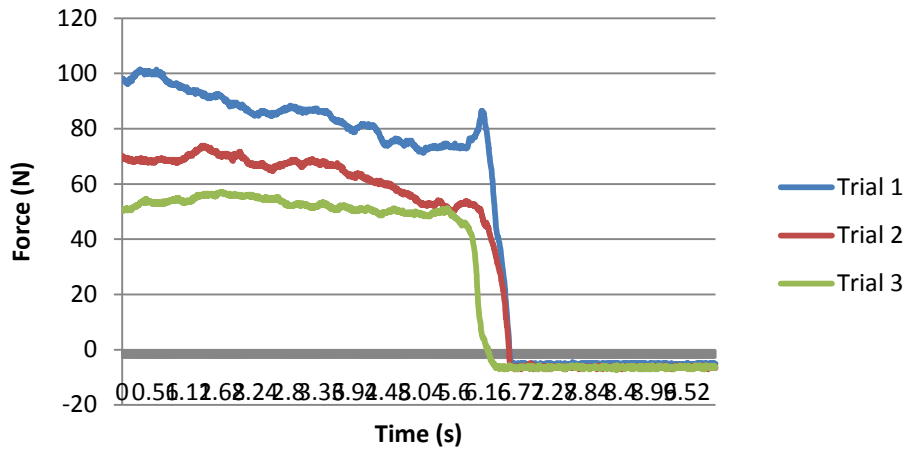

Alt 5 Circ CCW Mx

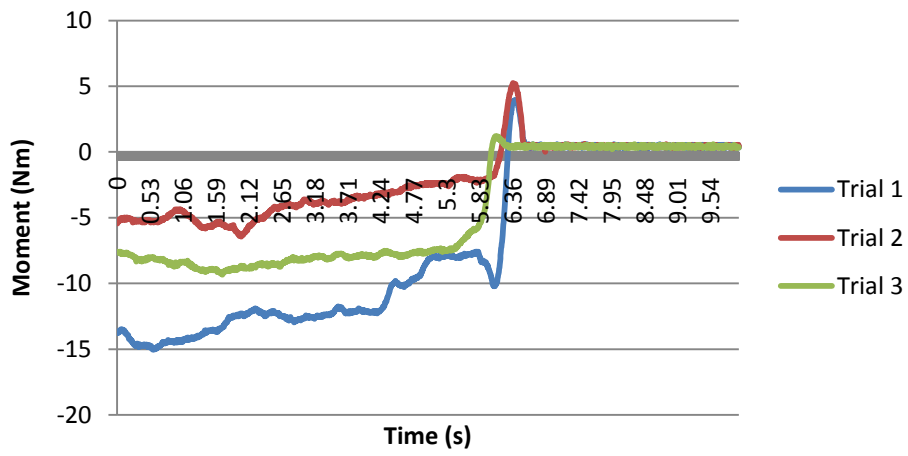

Alt 5 Circ CCW My

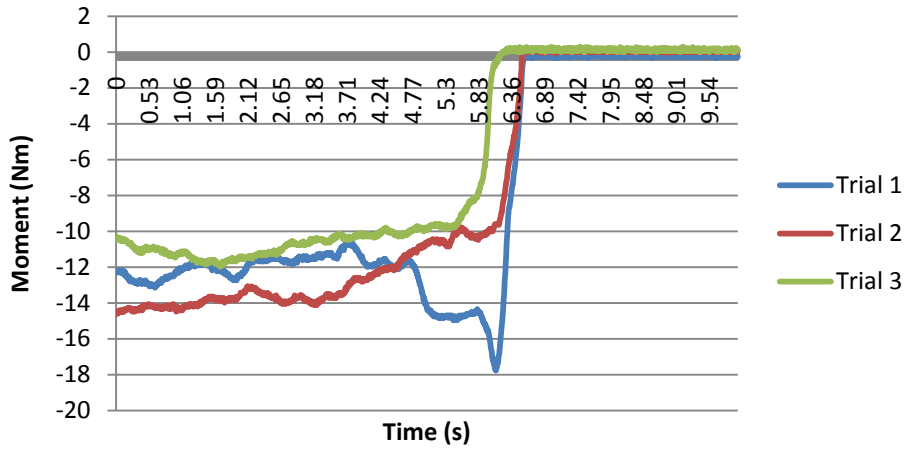

Alt 5 Circ CCW Mz

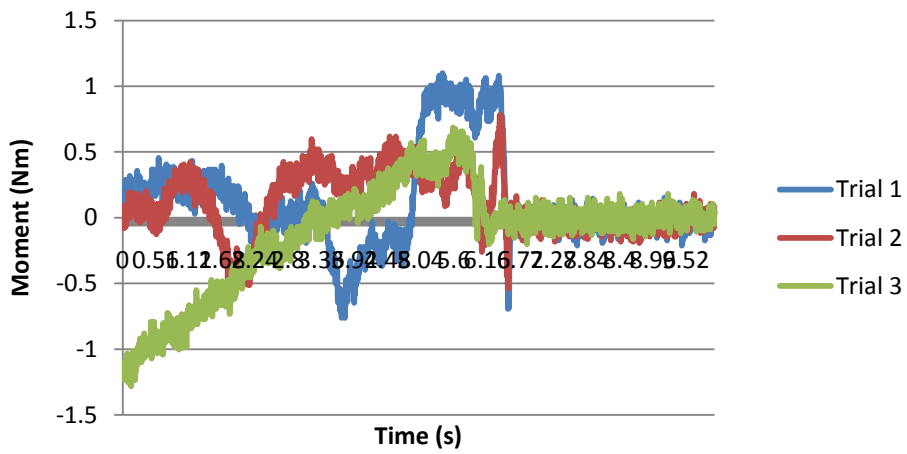

Alt 5 Circ CCW Average Fx

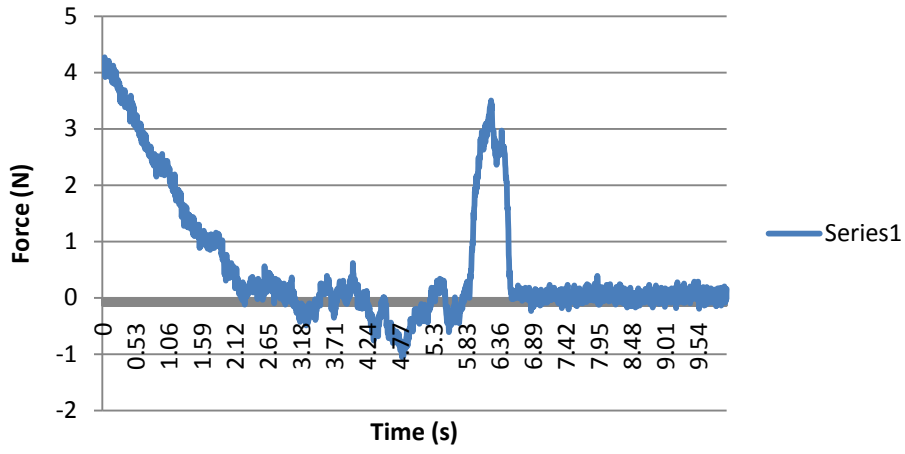

Alt 5 Circ CCW Average Fy

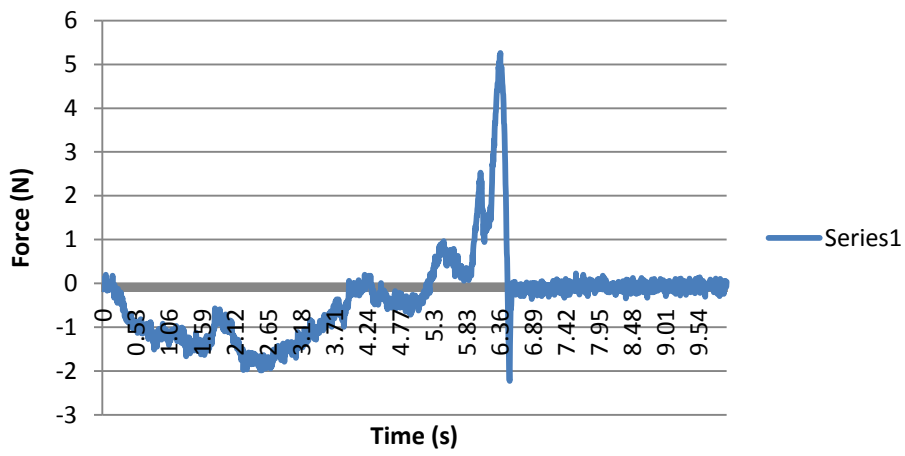

Alt 5 Circ CCW Average Fz

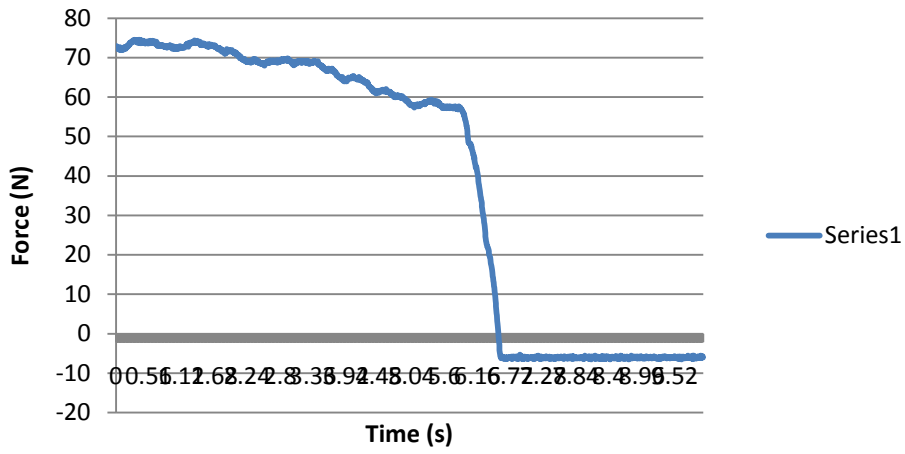

Alt 5 Circ CCW Average Mx

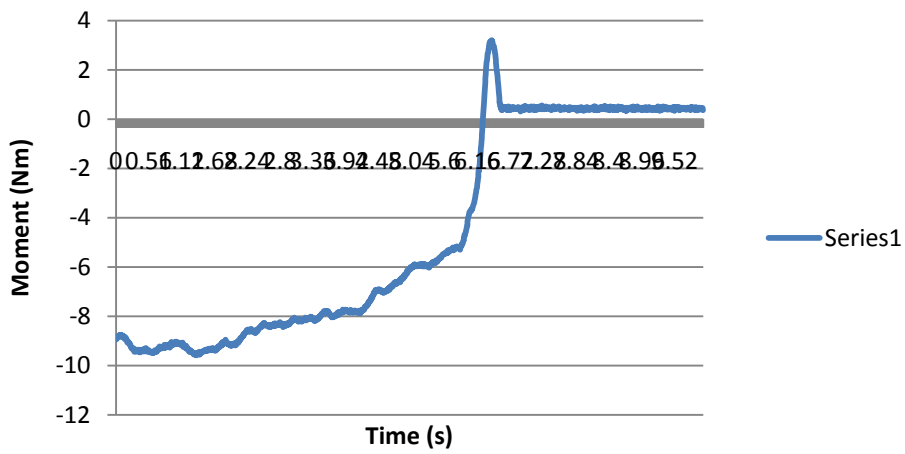

Alt 5 Circ CCW Average My

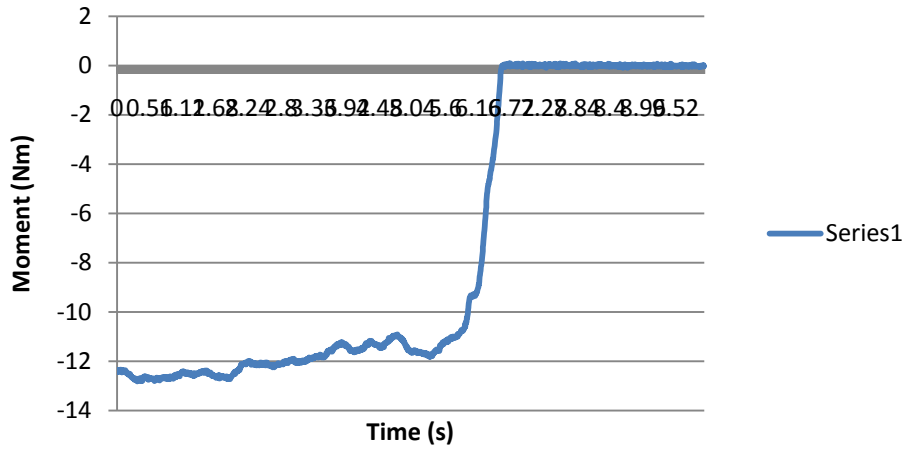

Alt 5 Circ CCW Average Mz

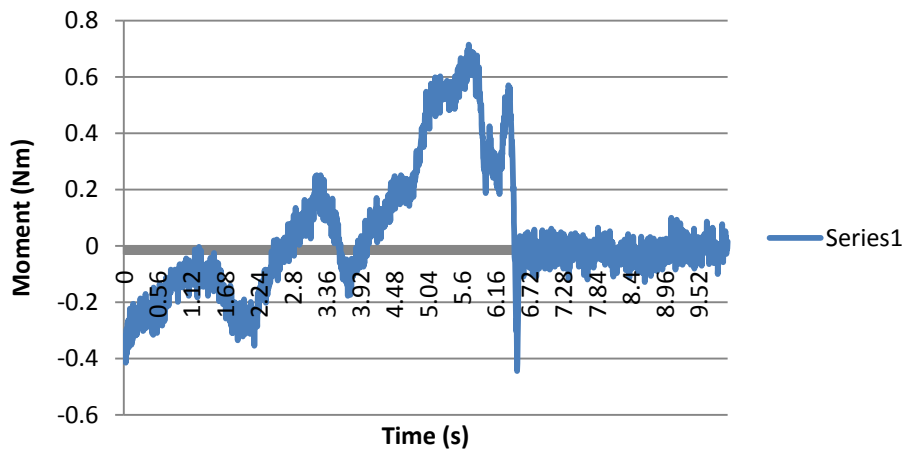

Alt 5 Circ CW Fx

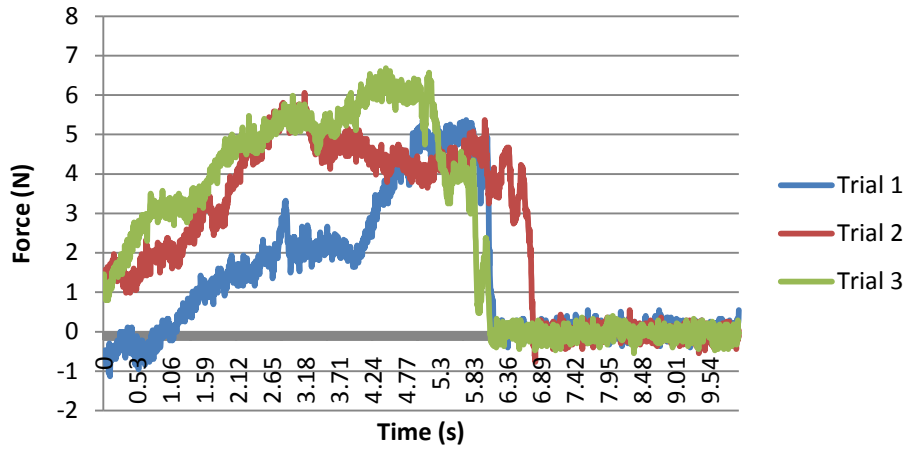

Alt 5 Circ CW Fy

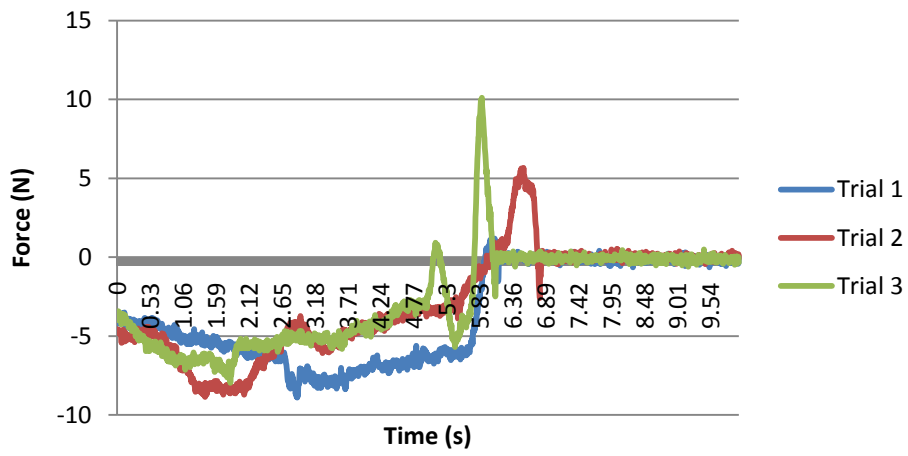

Alt 5 Circ CW Fz

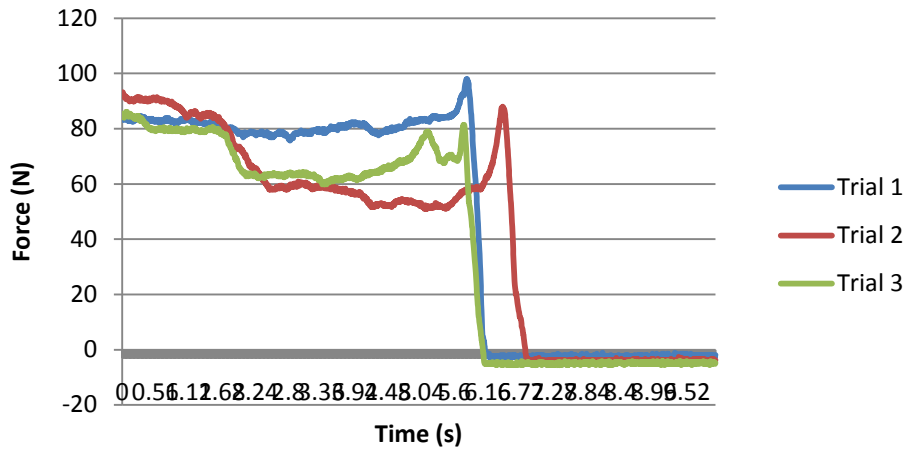

Alt 5 Circ CW Mx

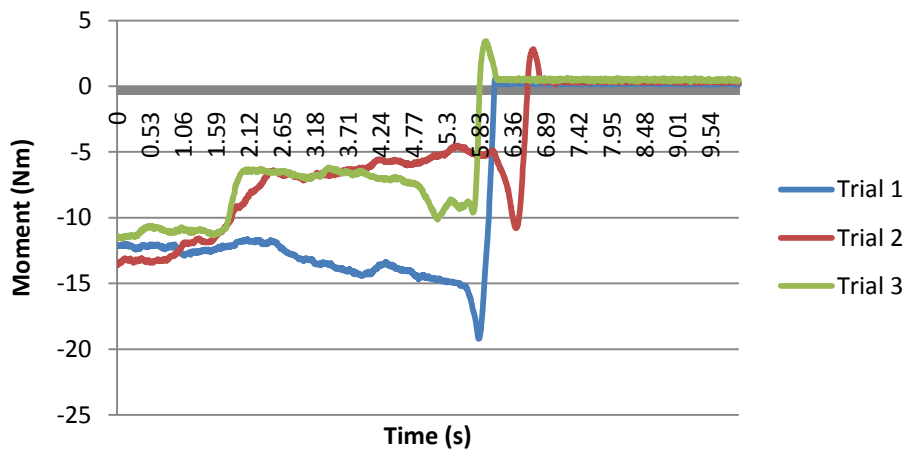

Alt 5 Circ CW My

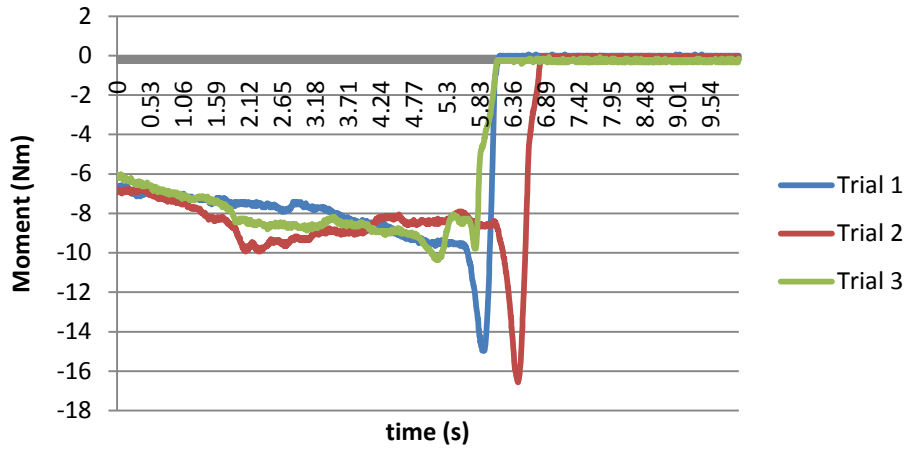

Alt 5 Circ CW Mz

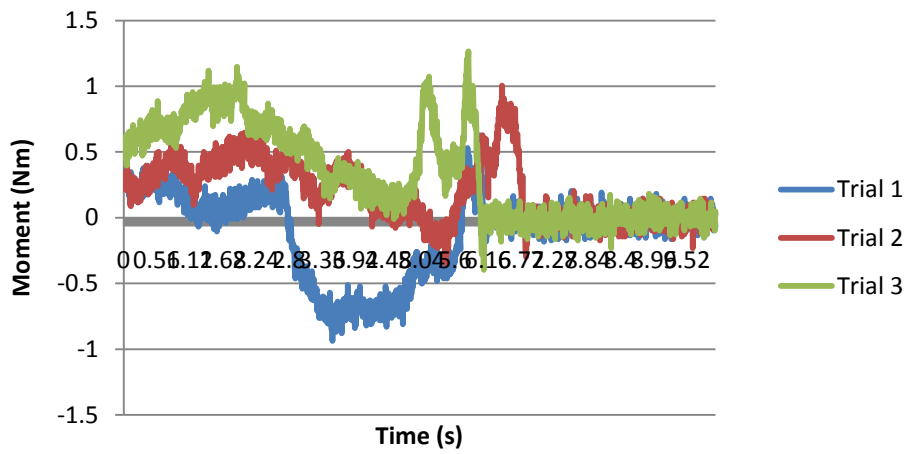

Alt 5 Circ CW Average Fx

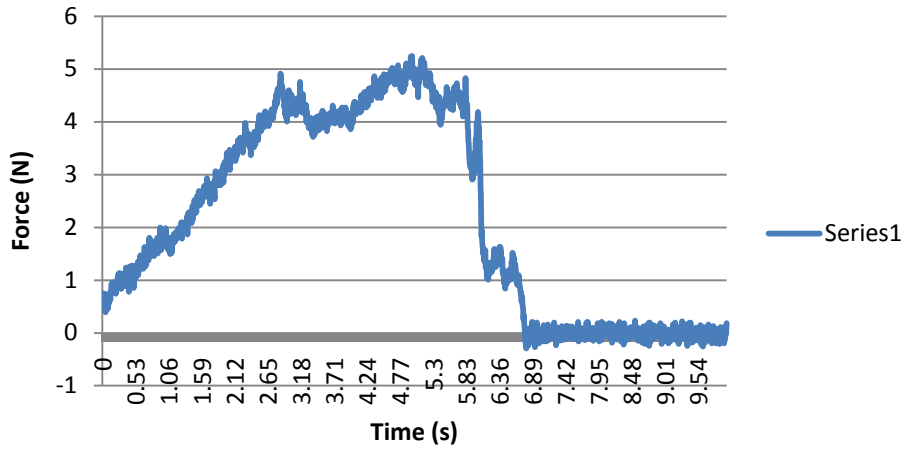

Alt 5 Circ CW Average Fy

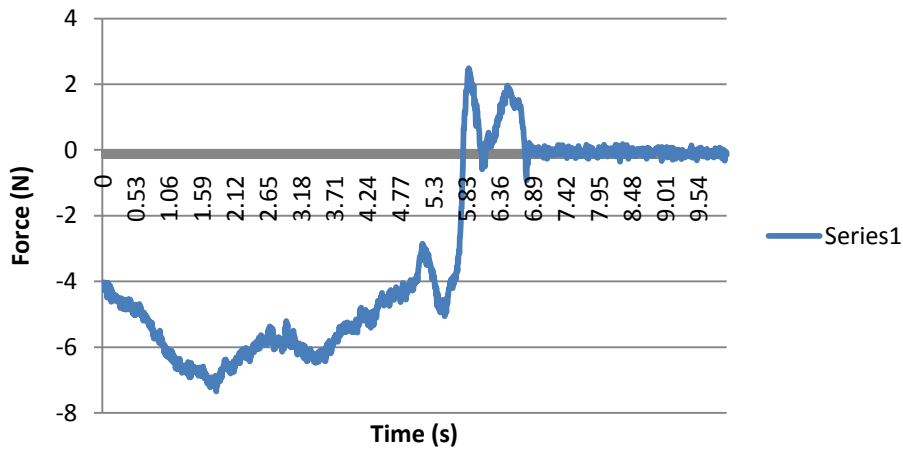

Alt 5 Circ CW Average Fz

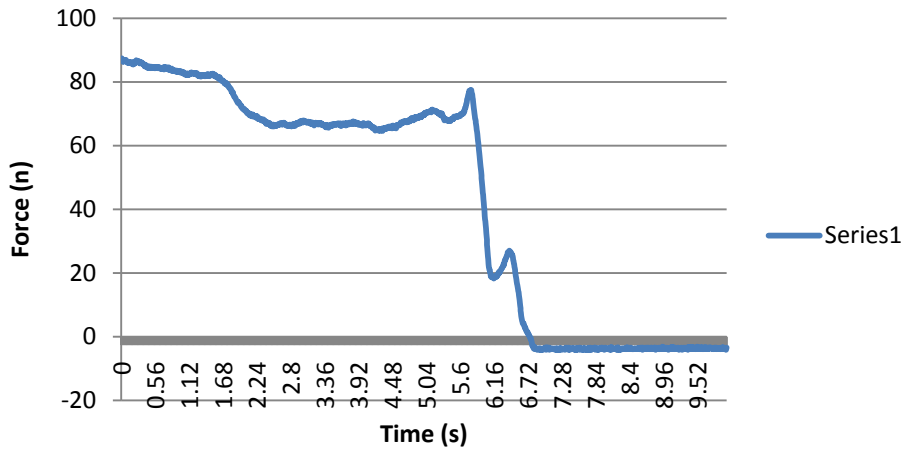

Alt 5 Circ CW Average Mx

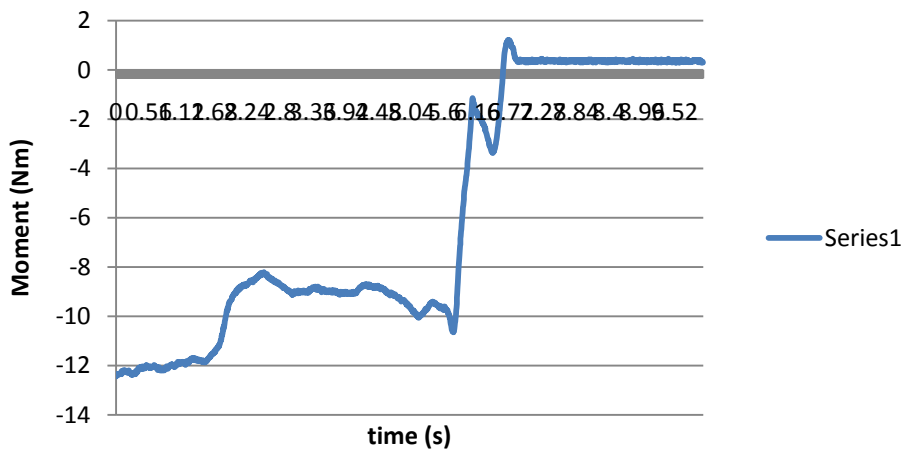

Alt 5 Circ CW Average My

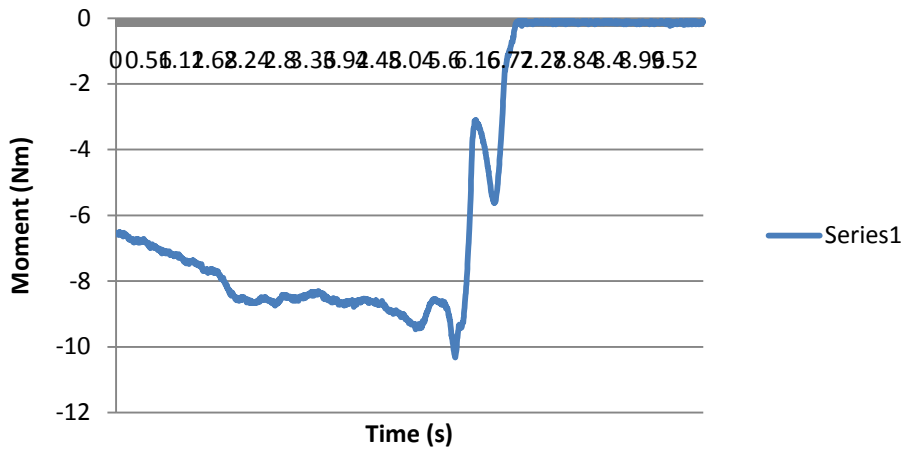

Alt 5 Circ CW Average Mz

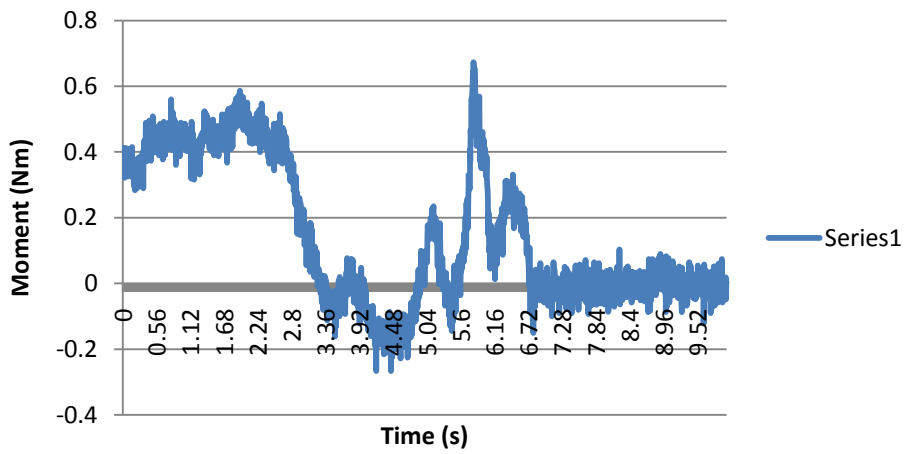

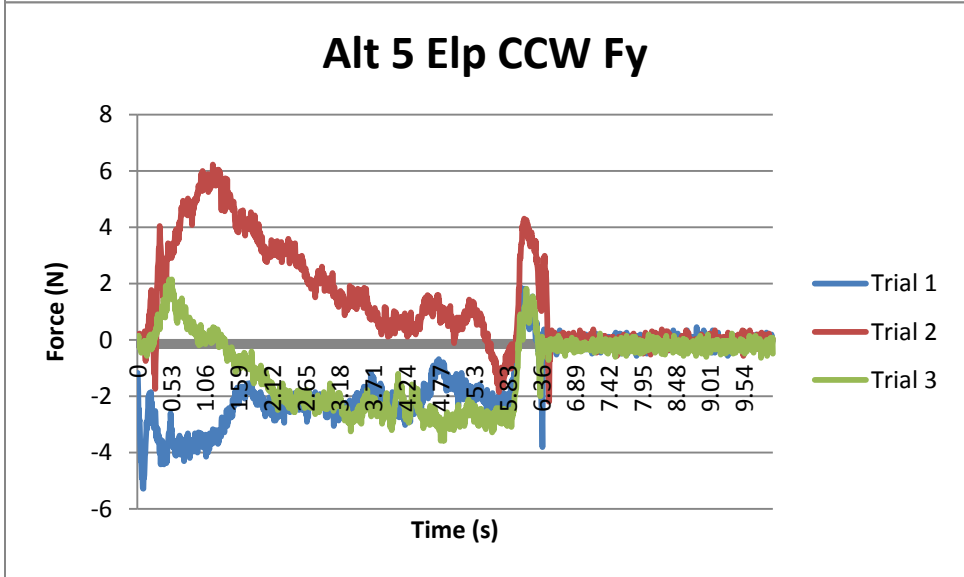
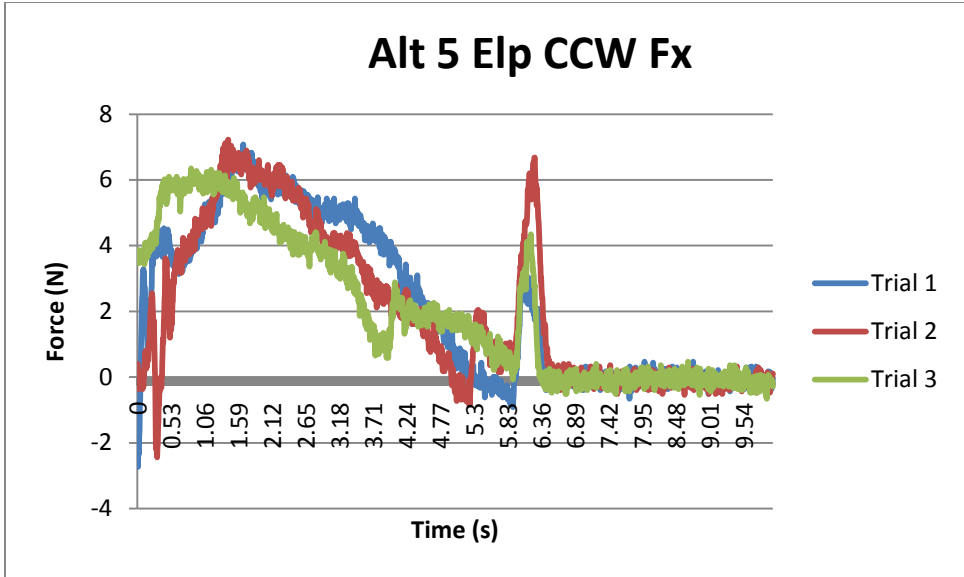

Alt 5 Elp CCW Fz

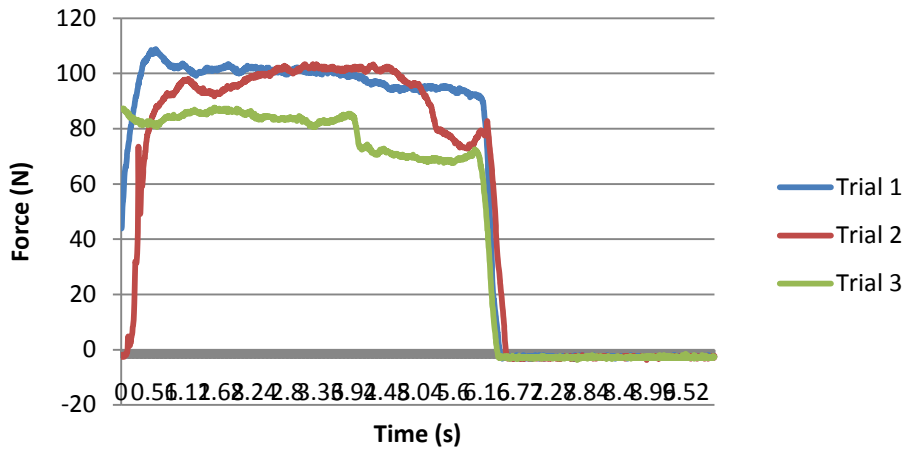

Alt 5 Elp CCW Mx

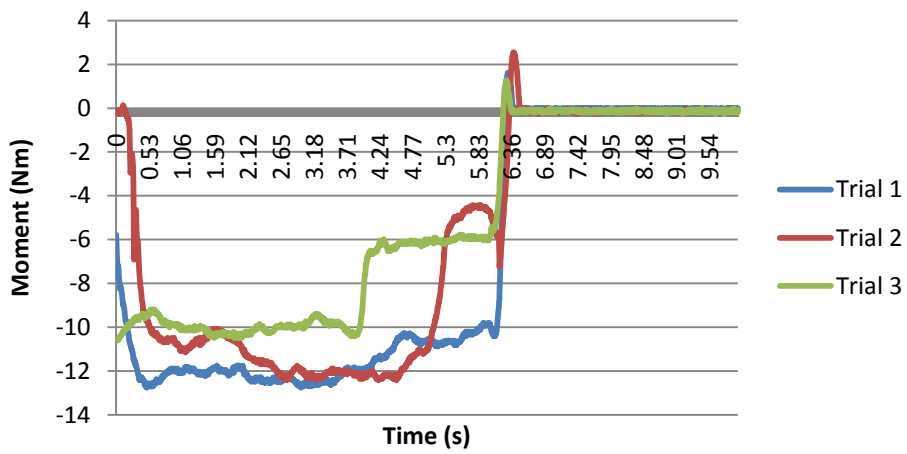

Alt 5 Elp CCW My

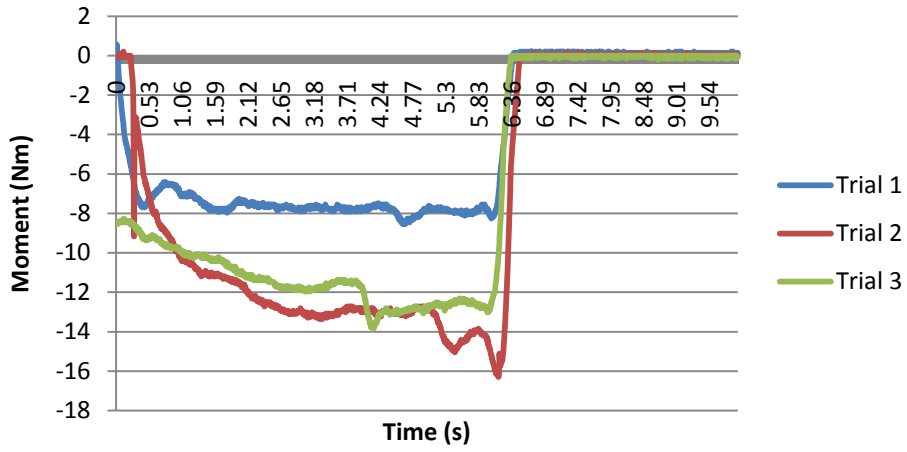

Alt 5 Elp CCW Mz

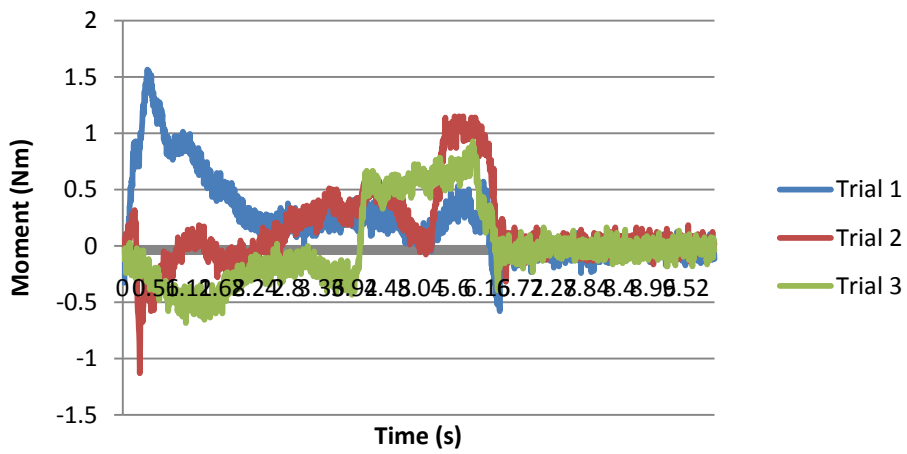

Alt 5 Elp CCW Average Fx

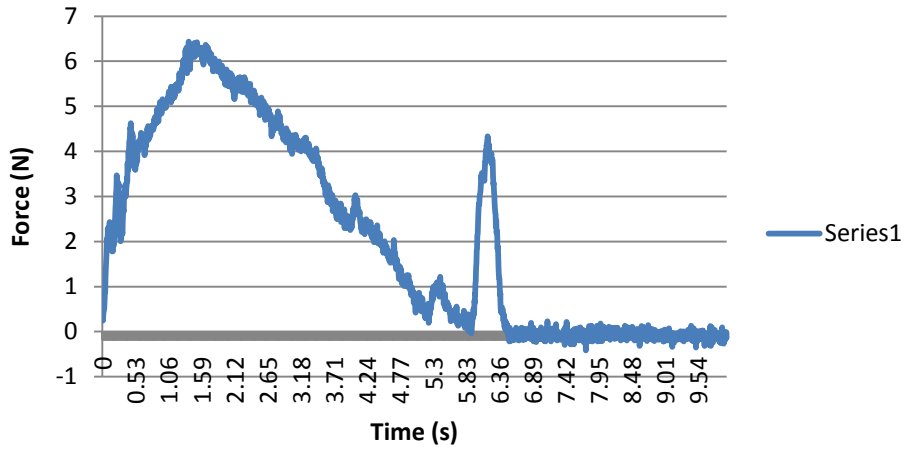

Alt 5 Elp CCW Average Fy

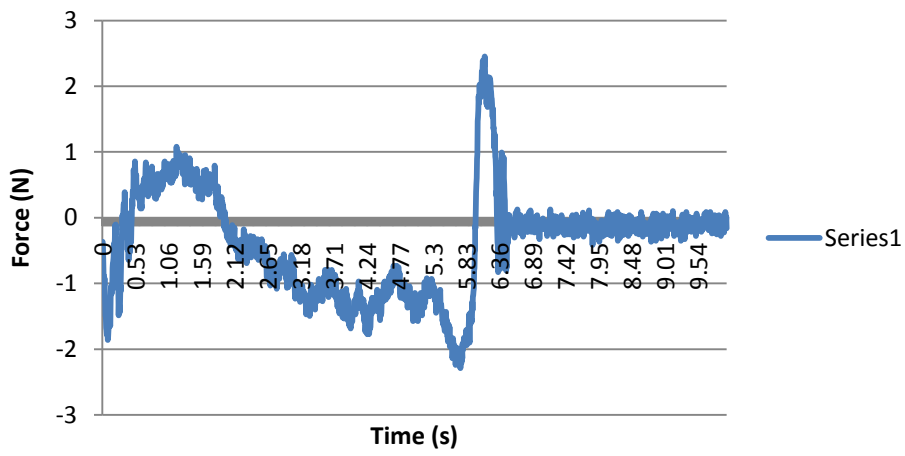

Alt 5 Elp CCW Average Fz

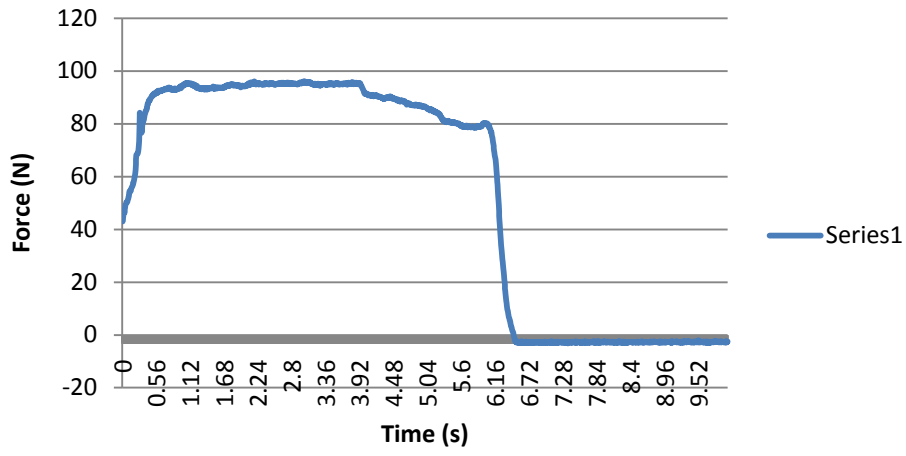

Alt 5 Elp CCW Average Mx

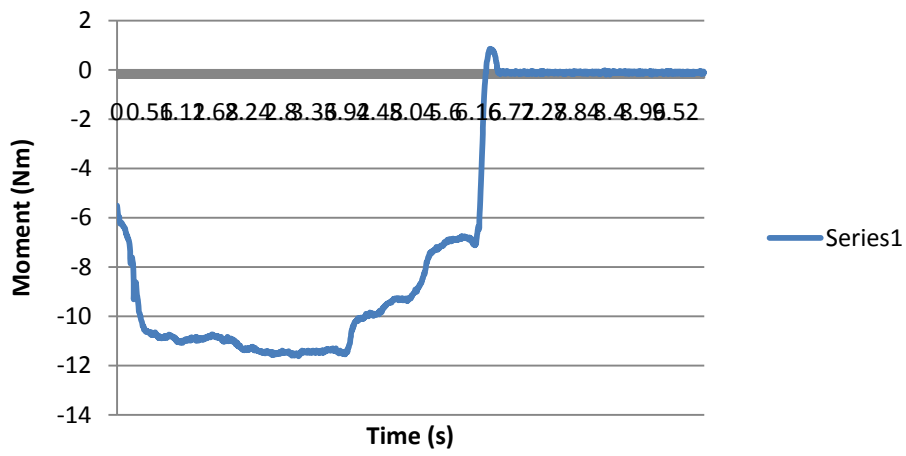

Alt 5 Elp CCW Average My

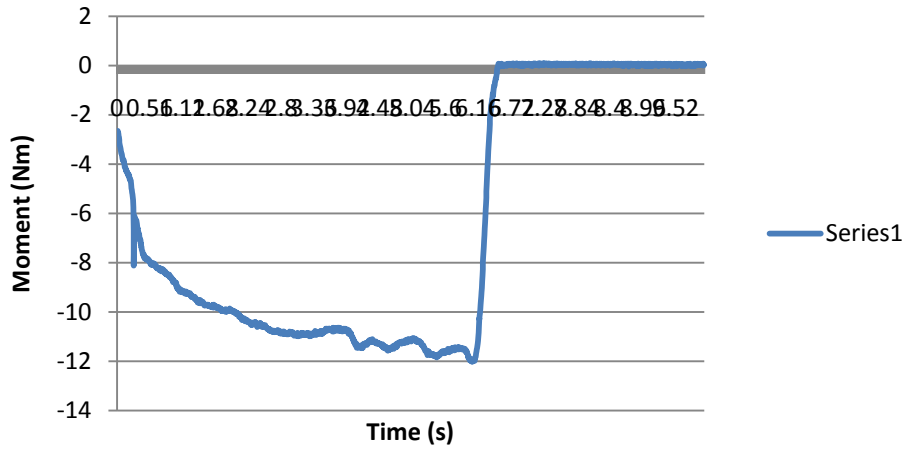

Alt 5 Elp CCW Average Mz

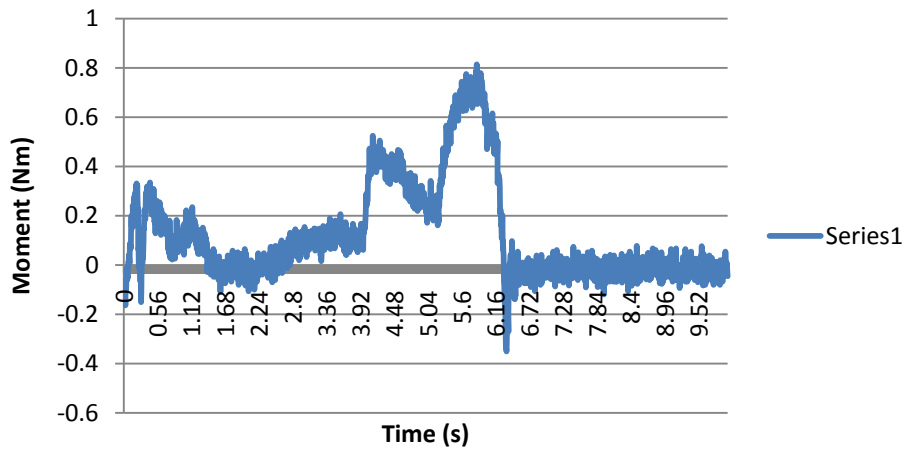

Alt 5 Elp CW Fx

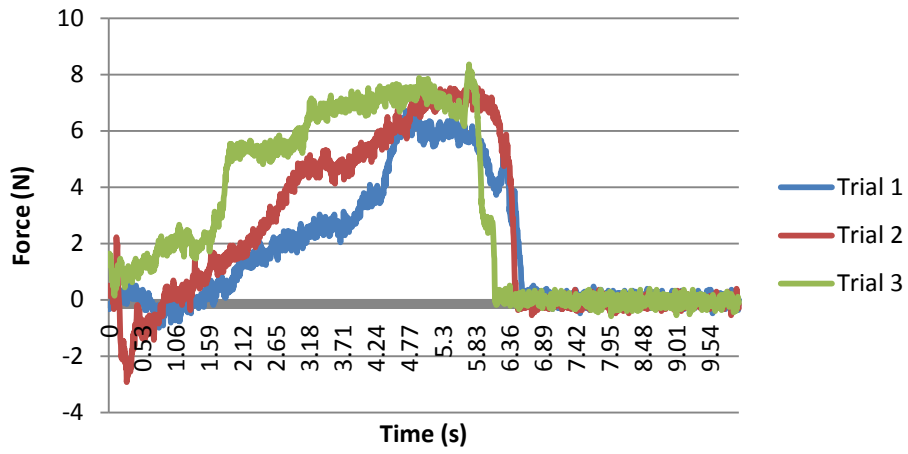

Alt 5 Elp CW Fy

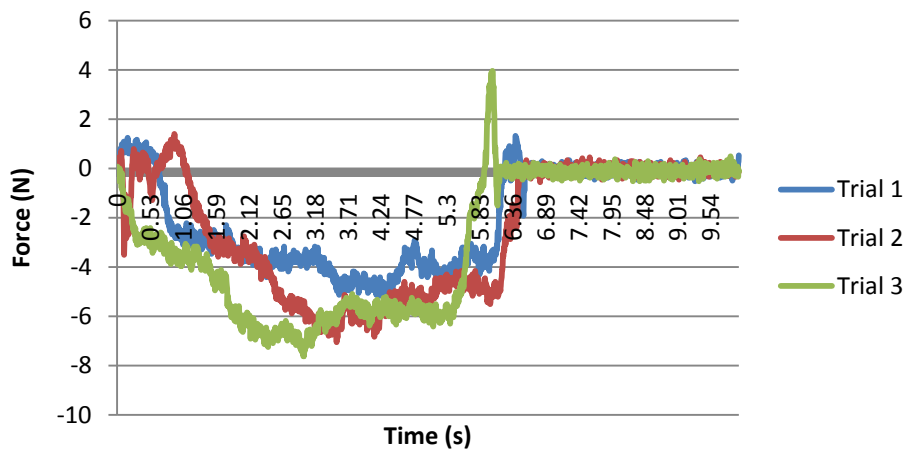

Alt 5 Elp CW Fz

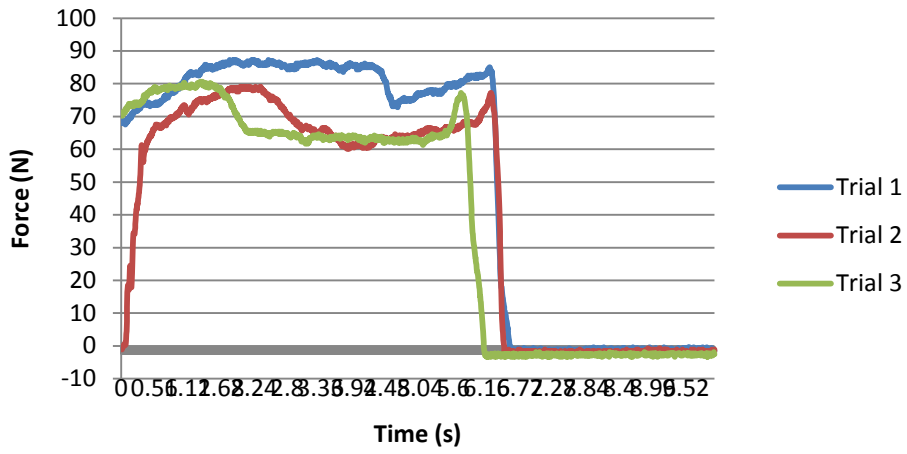

Alt 5 Elp CW Mx

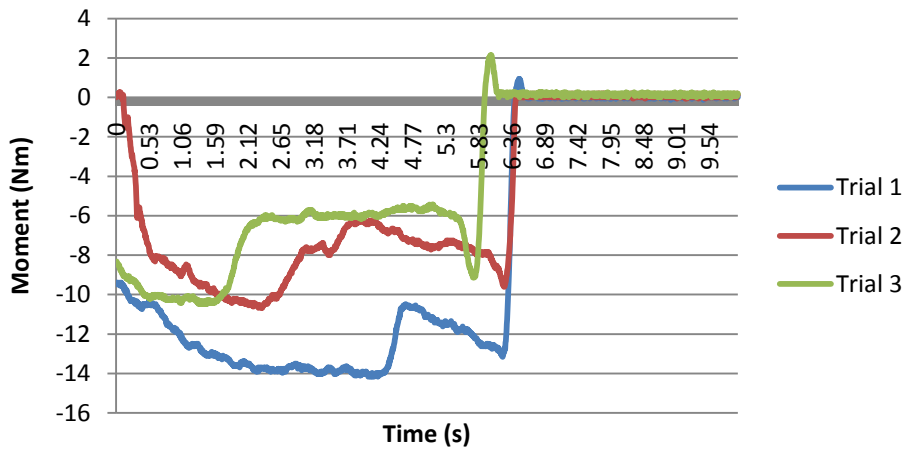

Alt 5 Elp CW My

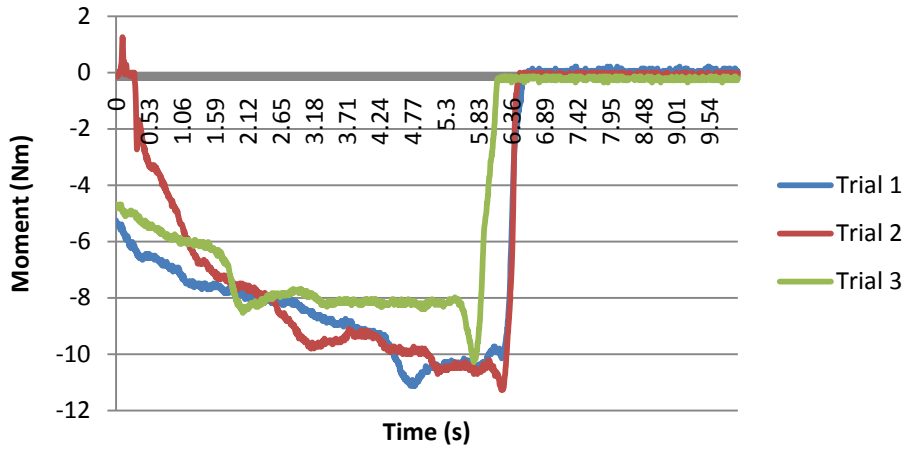

Alt 5 Elp CW Mz

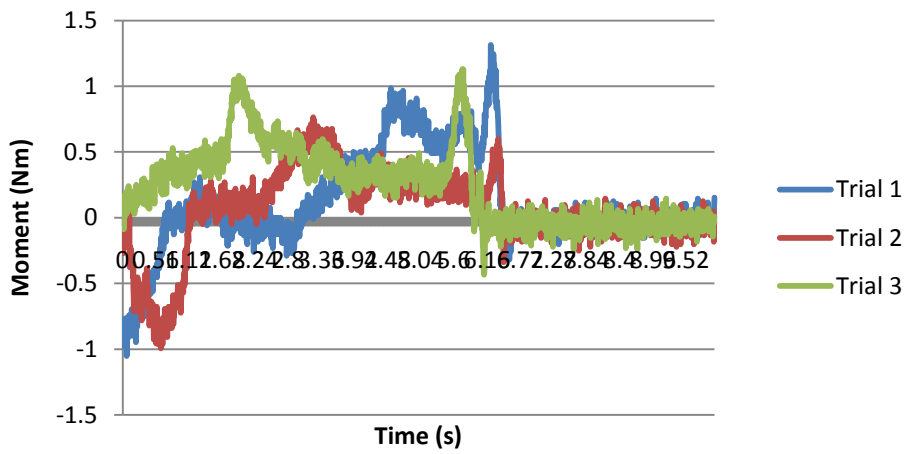

Alt 5 Elp CW Average Fx

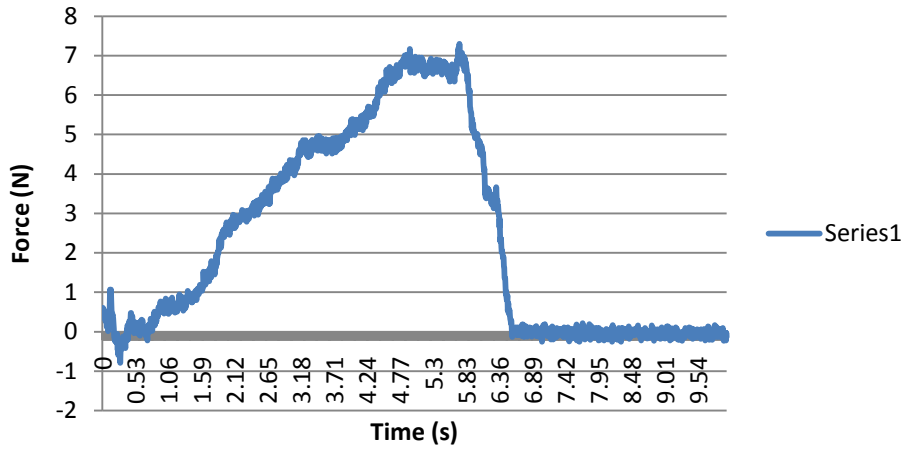

Alt 5 Elp CW Average Fy

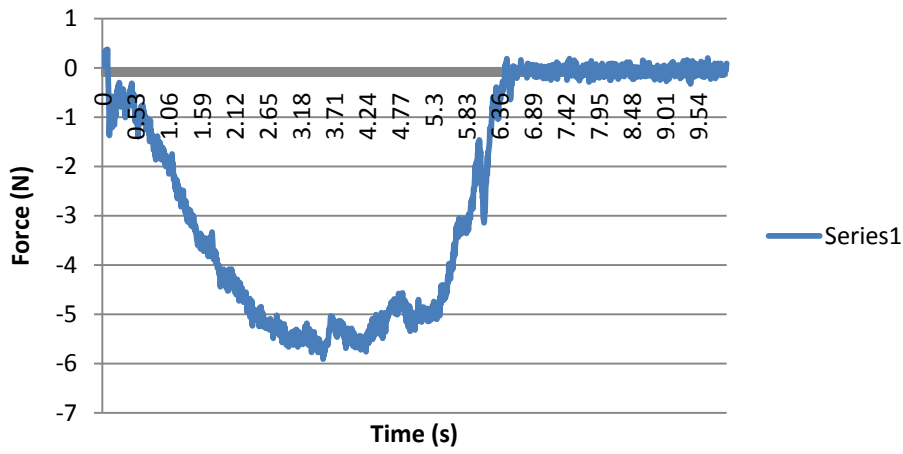

Alt 5 Elp CW Average Fz

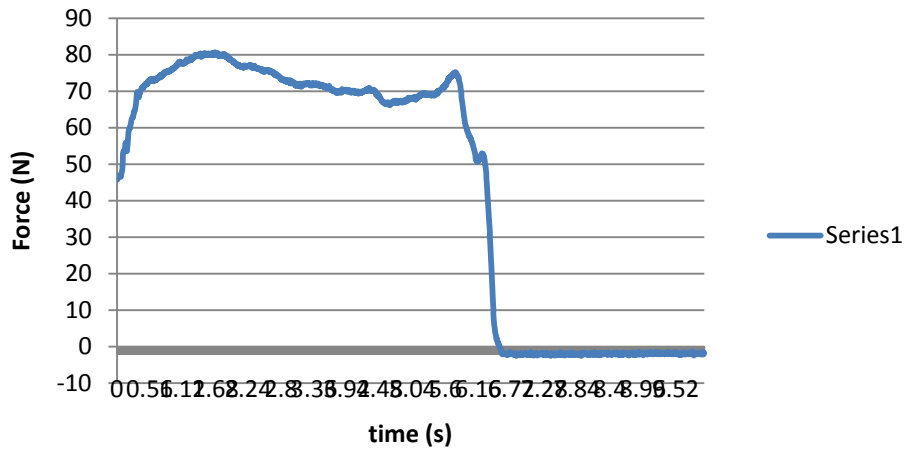

Alt 5 Elp CW Average Mx

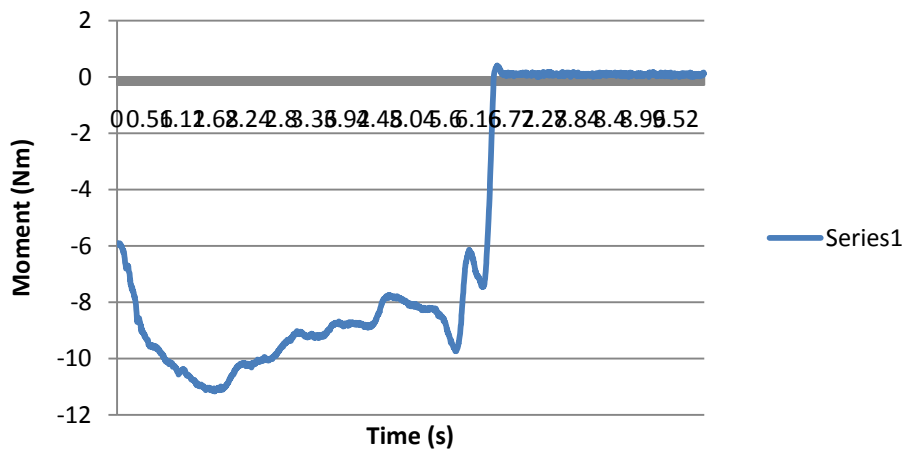

Alt 5 Elp CW Average My

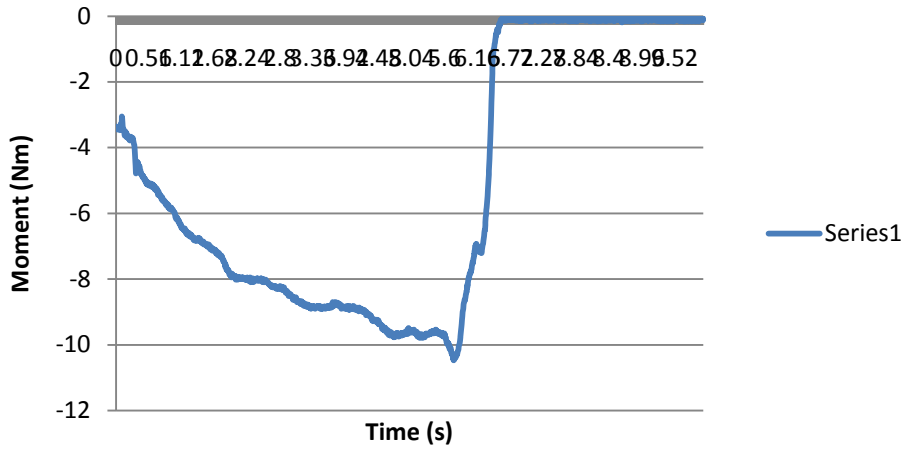

Alt 5 Elp CW Average Mz

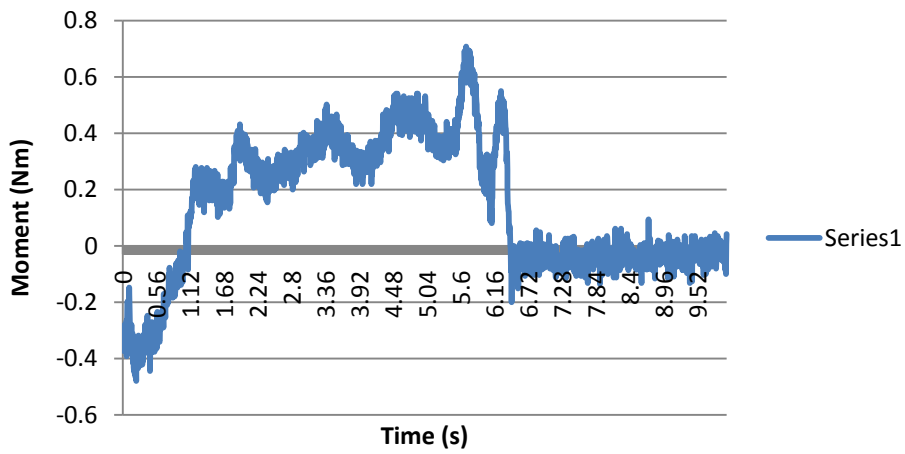

Alt 5 Horiz Linear Fx

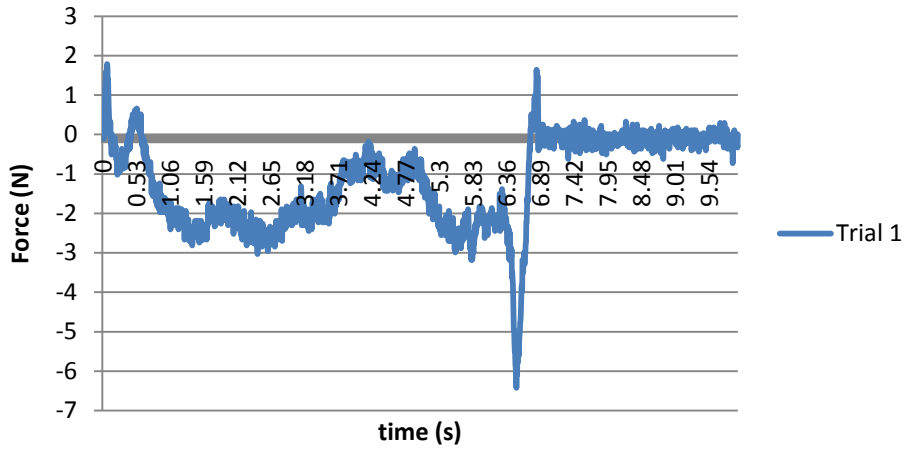

Alt 5 Horiz Linear Fy

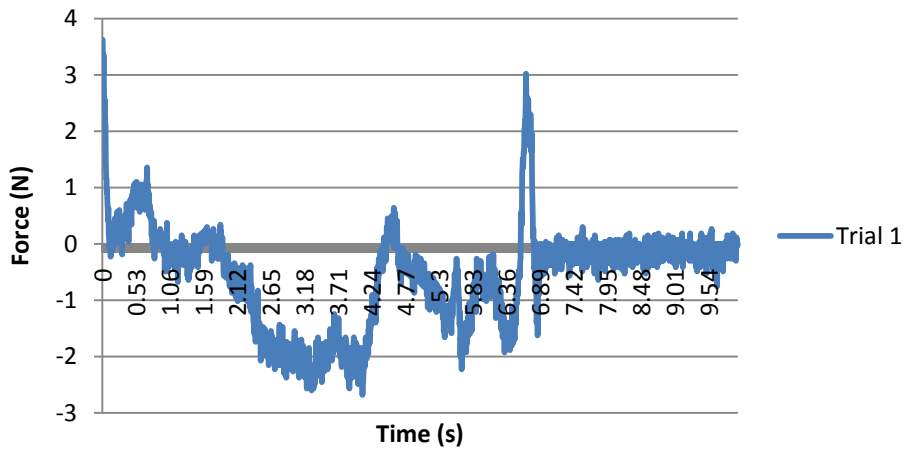

Alt 5 Horiz Linear Fz

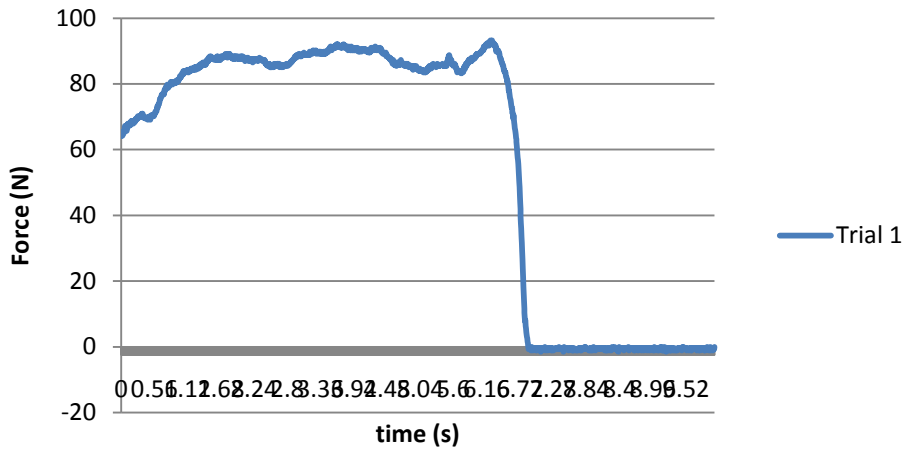

Alt 5 Horiz Linear Mx

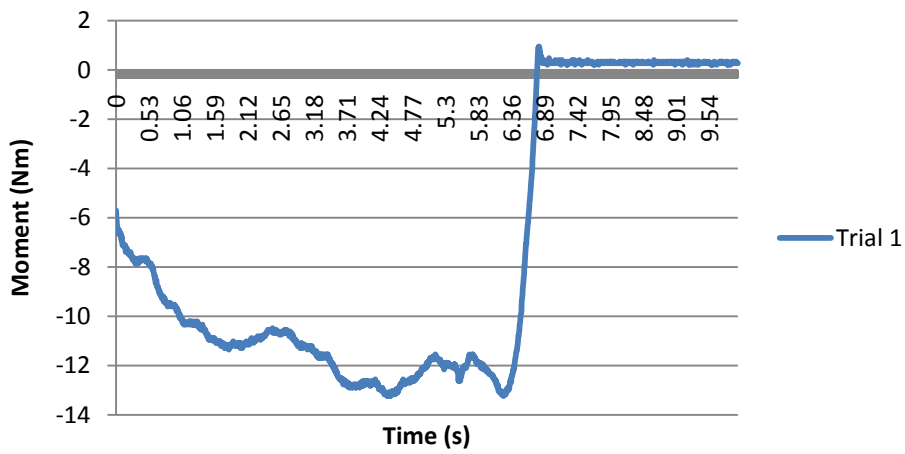

Alt 5 Horiz Linear My

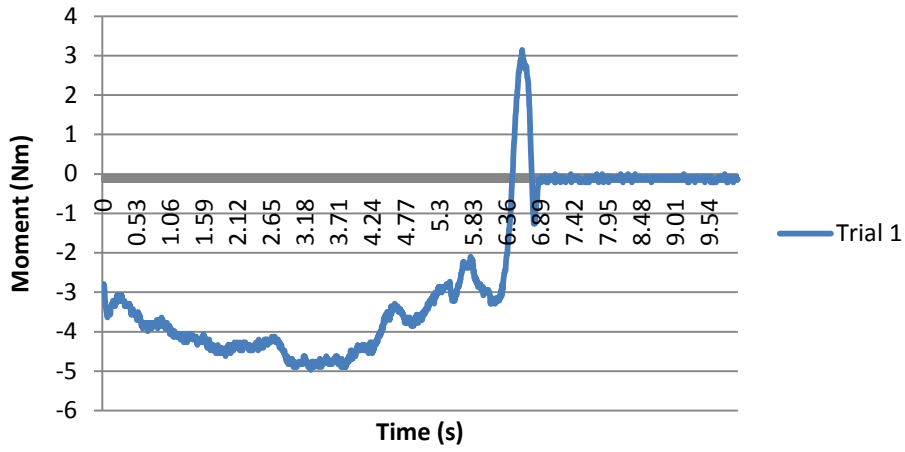

Alt 5 Horiz Linear Mz

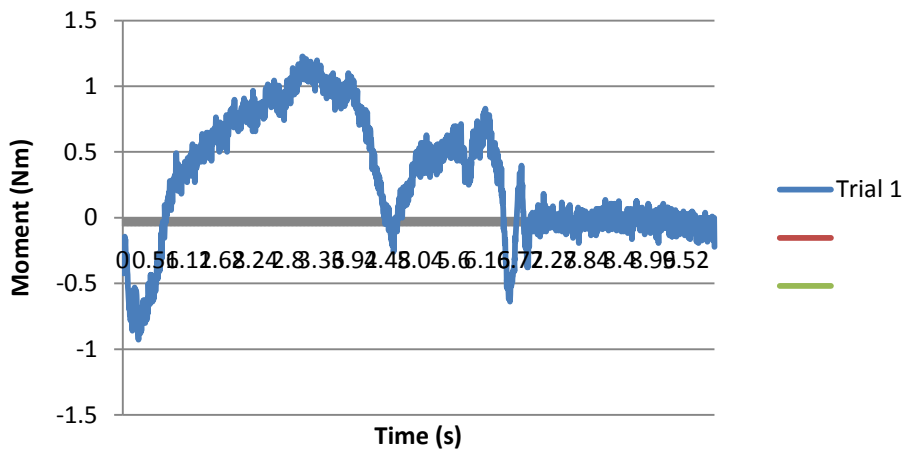

Alt 5 Horiz Linear Average Fx

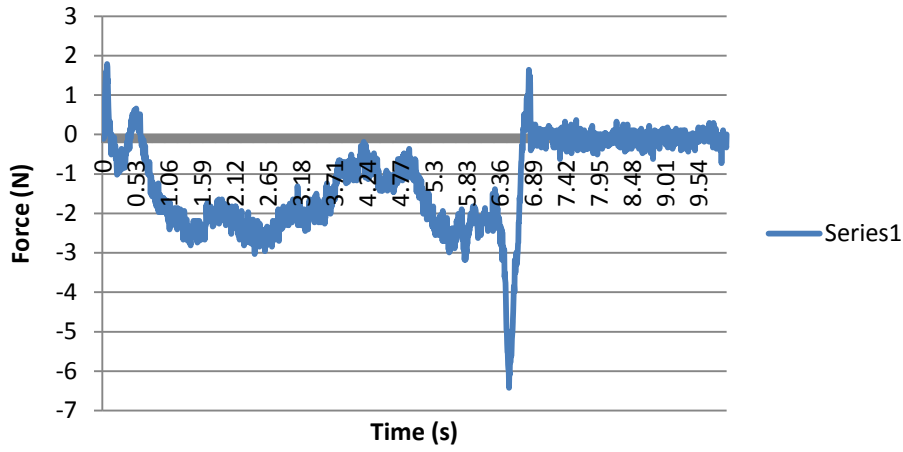

Alt 5 Horiz Linear Average Fy

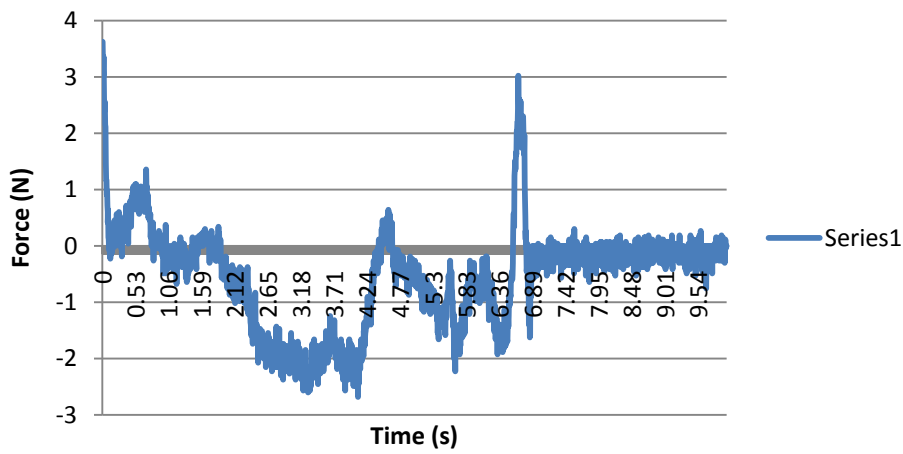

Alt 5 Horiz Linear Average Fz

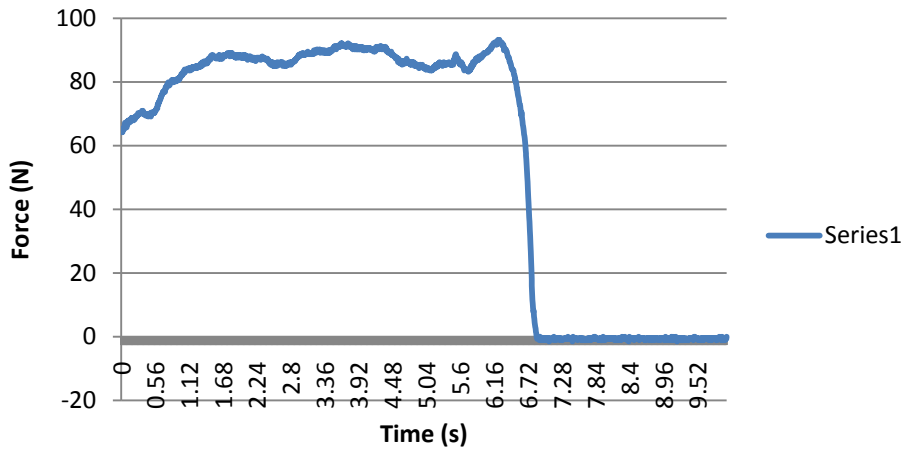

Alt 5 Horiz Linear Average Mx

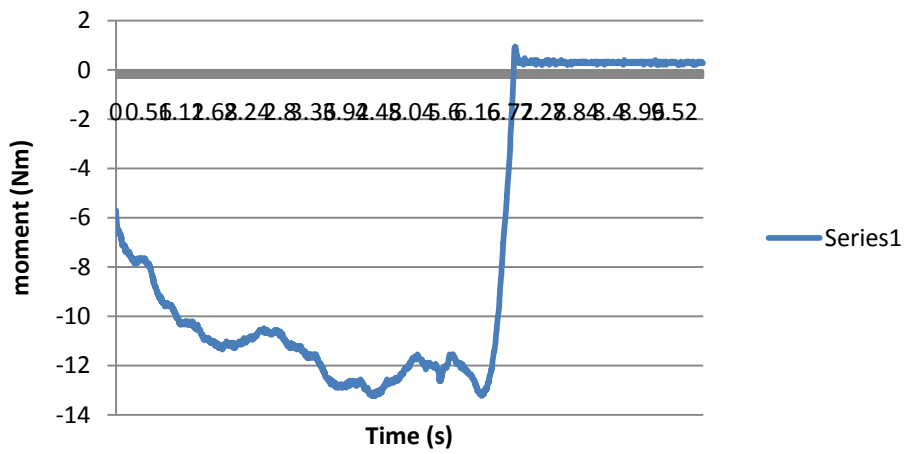

Alt 5 Horiz Linear Average My

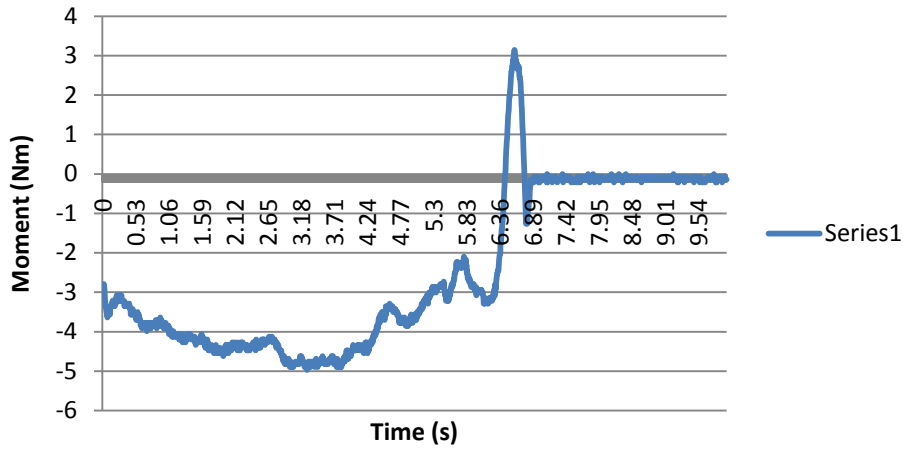

Alt 5 Horiz Linear Average Mz

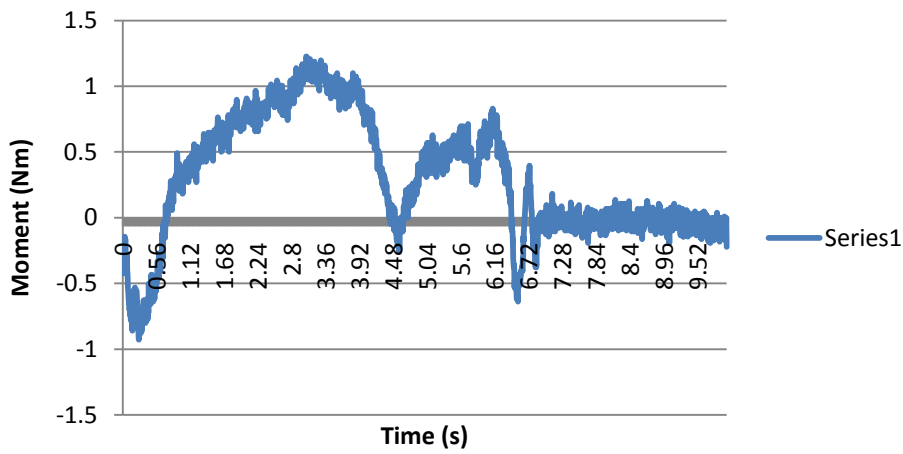

Alt 5 Vertical Linear Fx

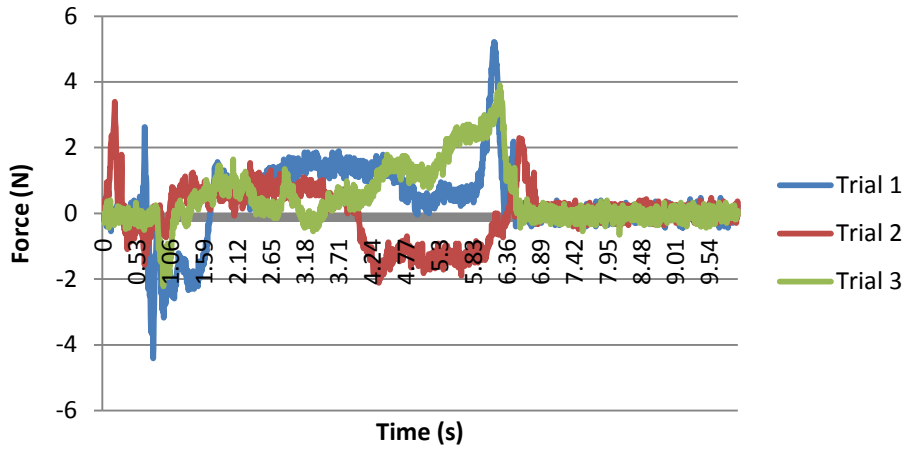

Alt 5 Vertical Linear Fy

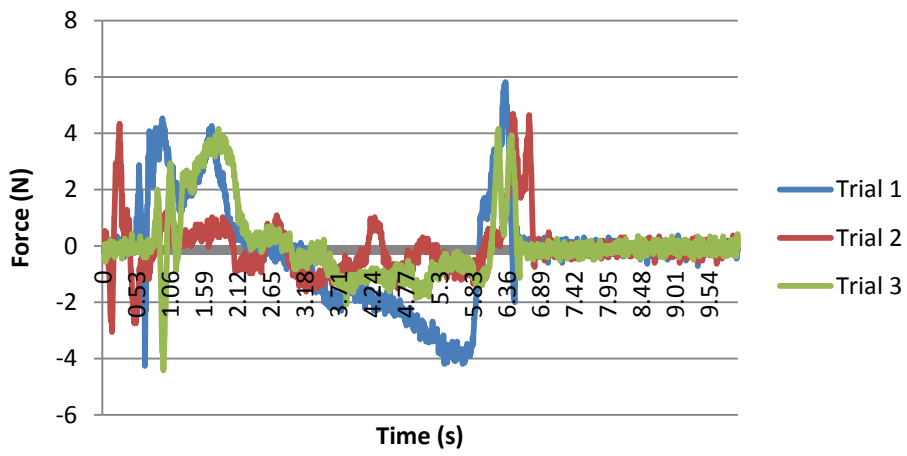

Alt 5 Vertical Linear Fz

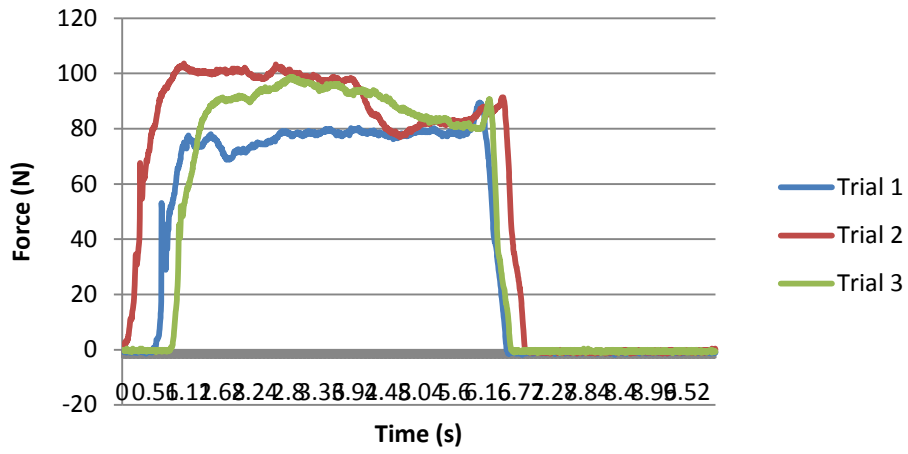

Alt 5 Vertical Linear Mx

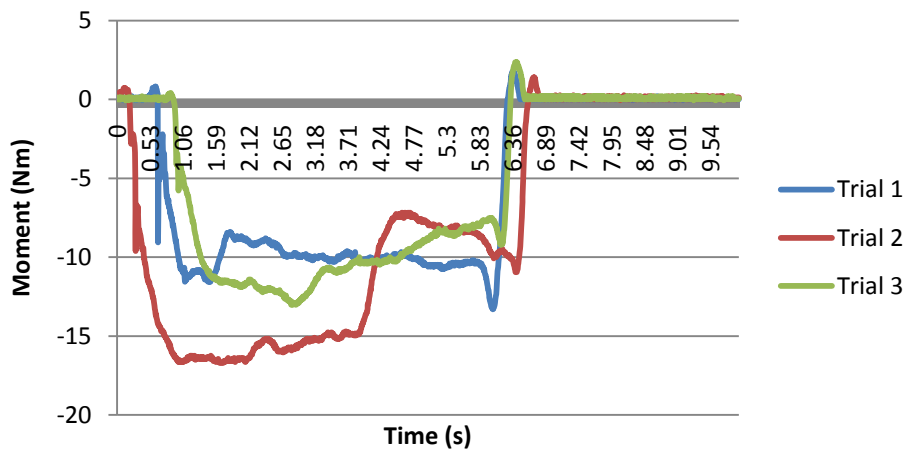

Alt 5 Vertical Linear My

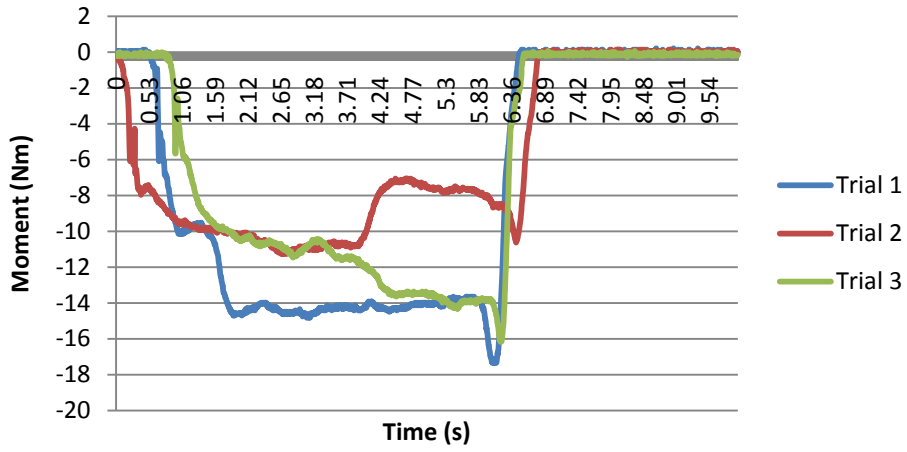

Alt 5 Vertical Linear Mz

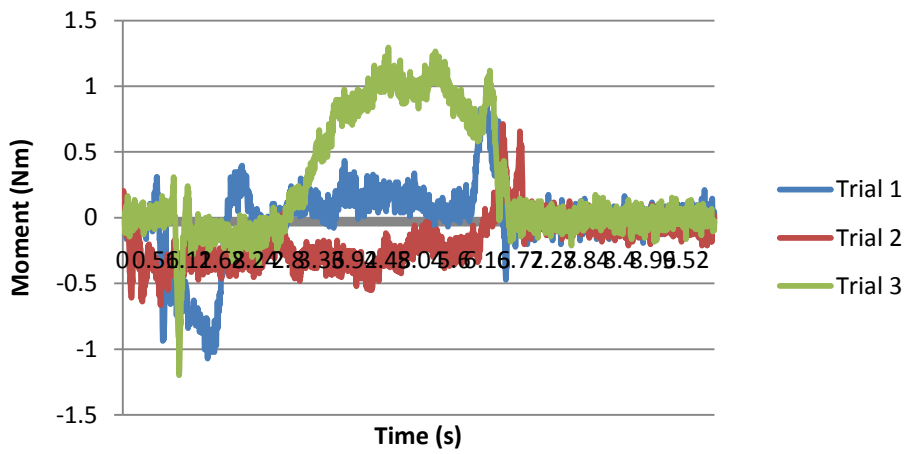

Alt 5 Vertical Linear Average Fx

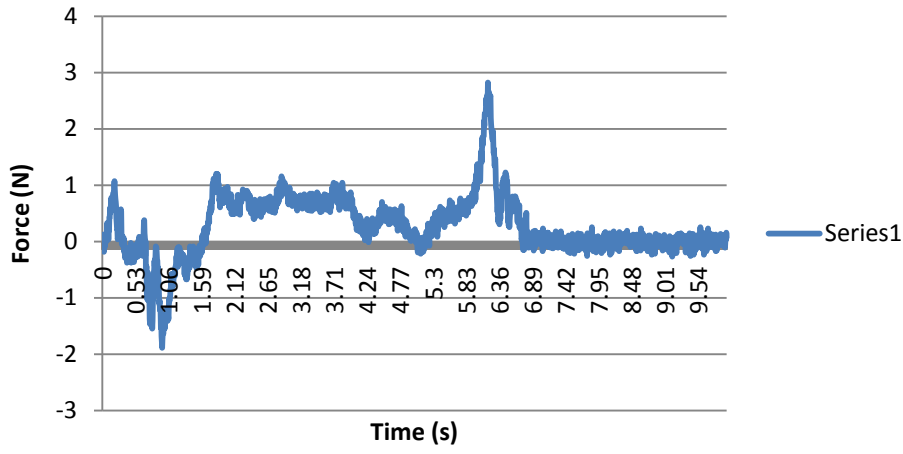

Alt 5 Vertical Linear Average Fy

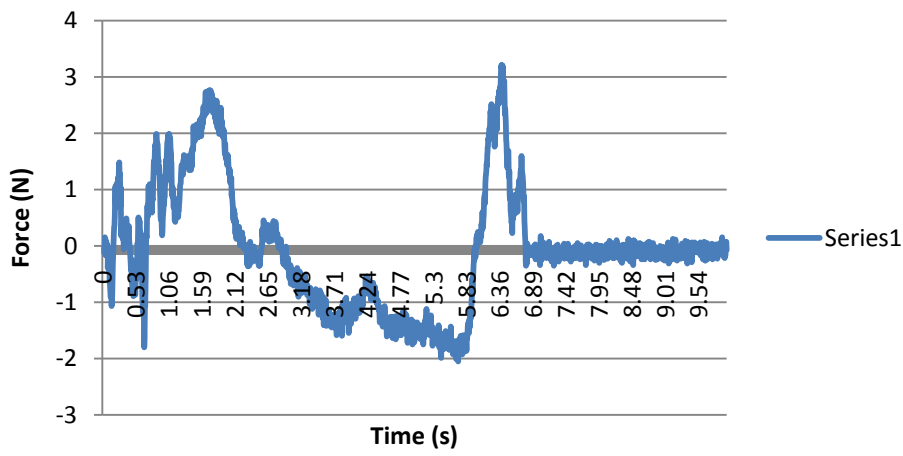

Alt 5 Vertical Linear Average Fz

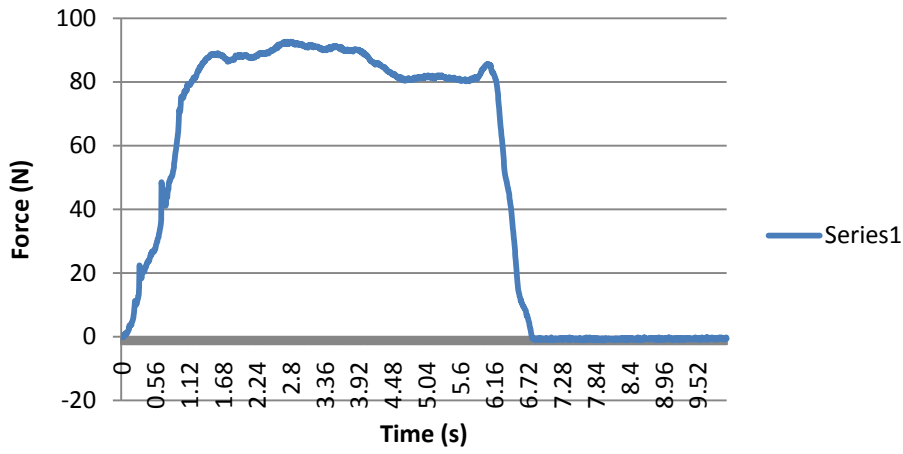

Alt 5 Vertical Linear Average Mx

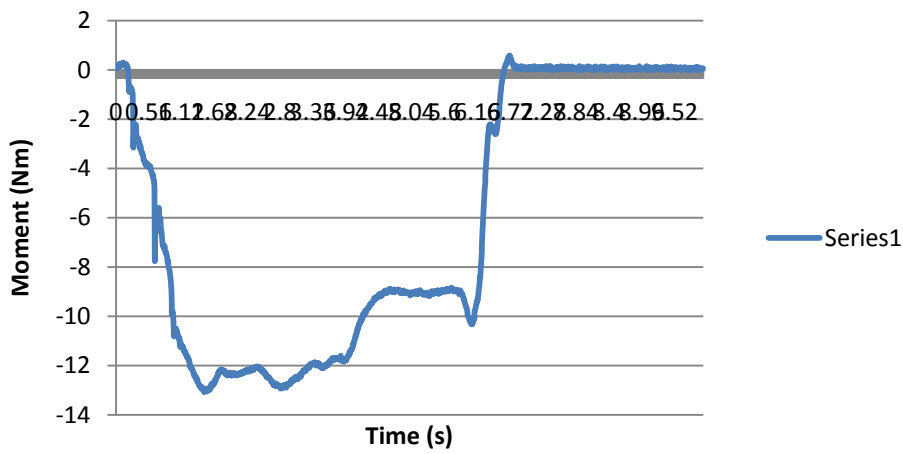

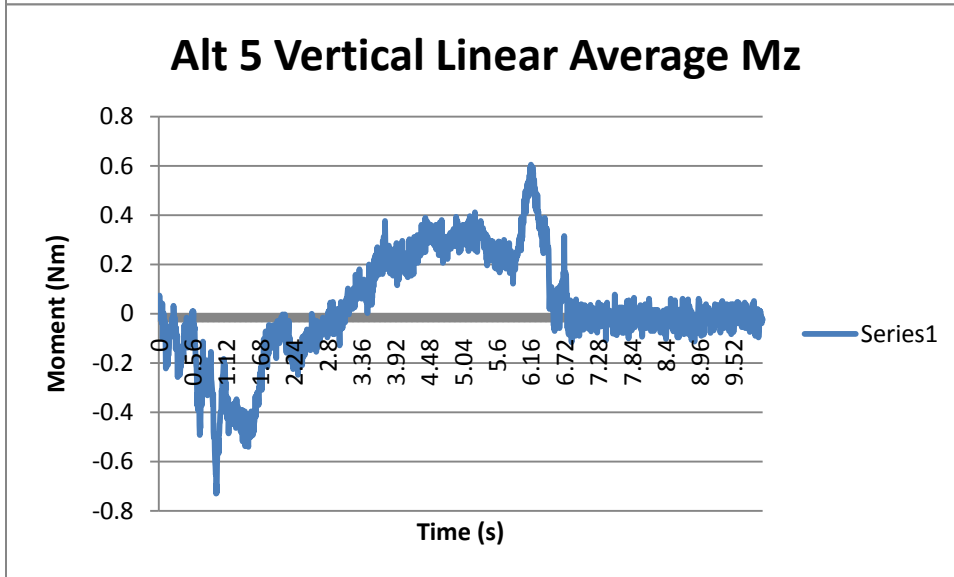
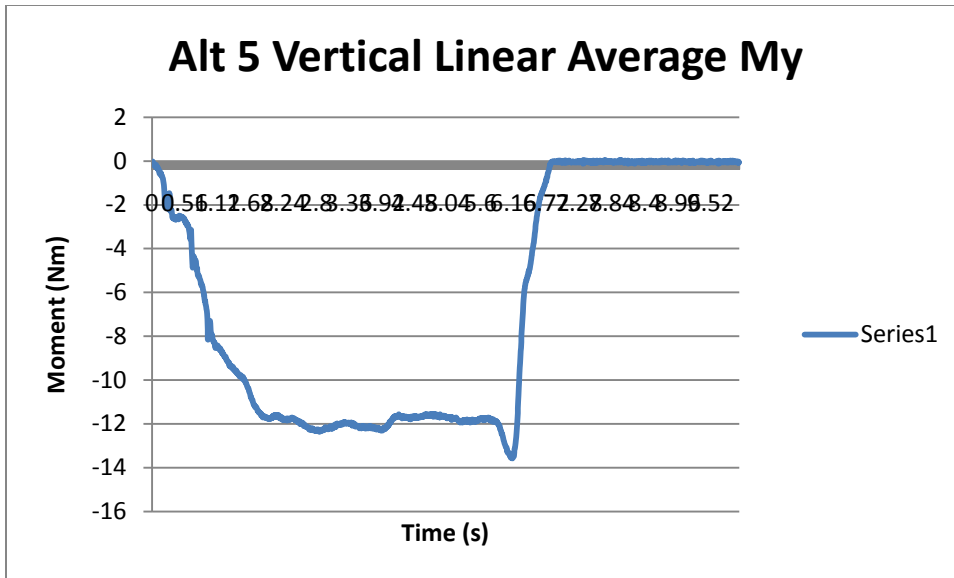

Dr. Dunn Standard Scalpel

Dr. Dunn Standard Circ CCW Fx

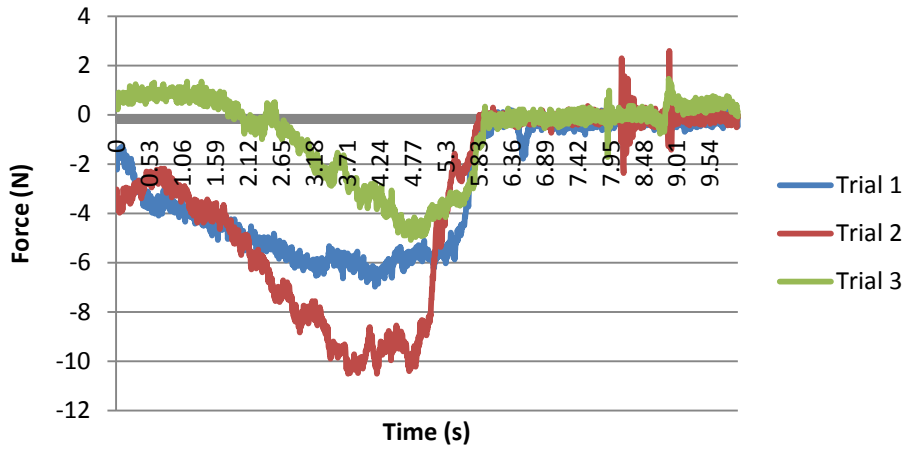

Dr. Dunn Standard Circ CCW Fy

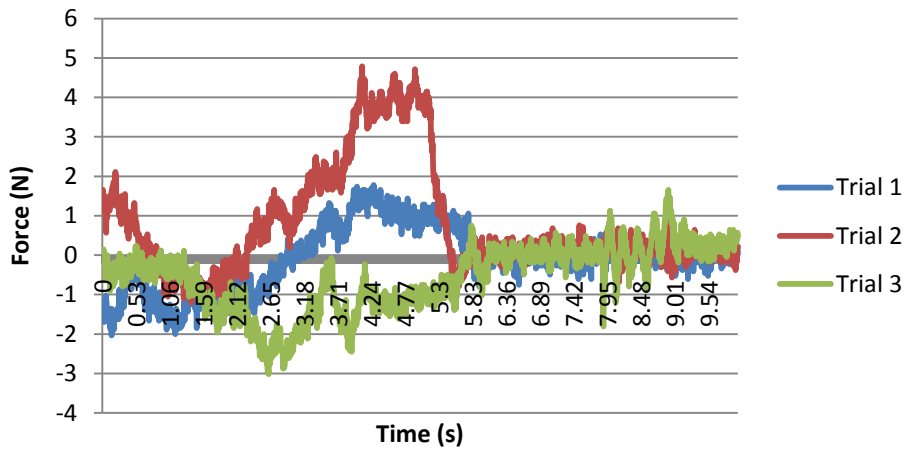

Dr. Dunn Standard Circ CCW Fz

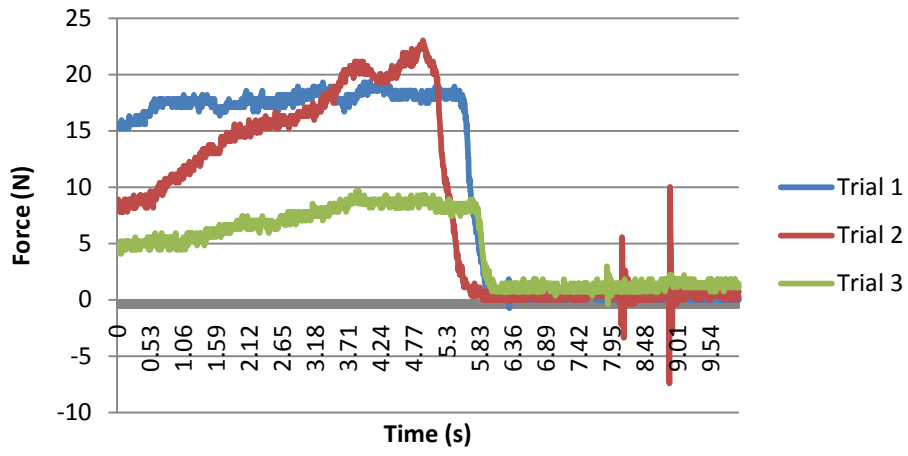

Dr. Dunn Standard Circ CCW Mx

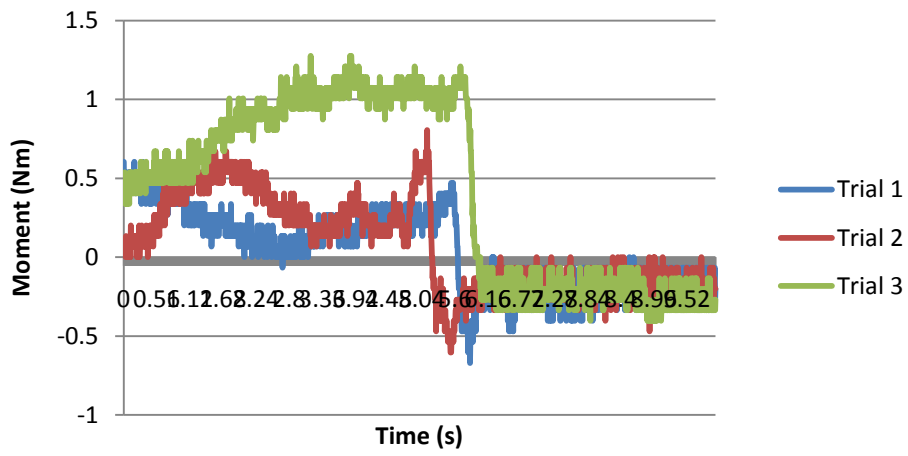

Dr. Dunn Standard Circ CCW My

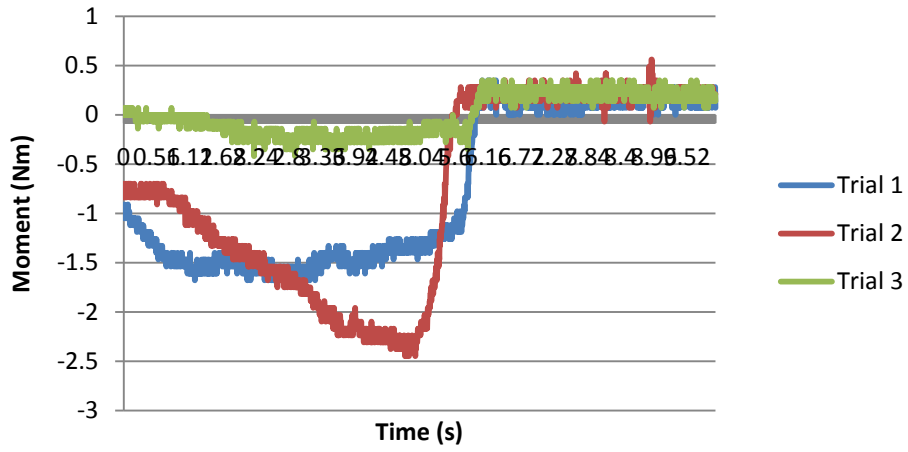

Dr. Dunn Standard Circ CCW Mz

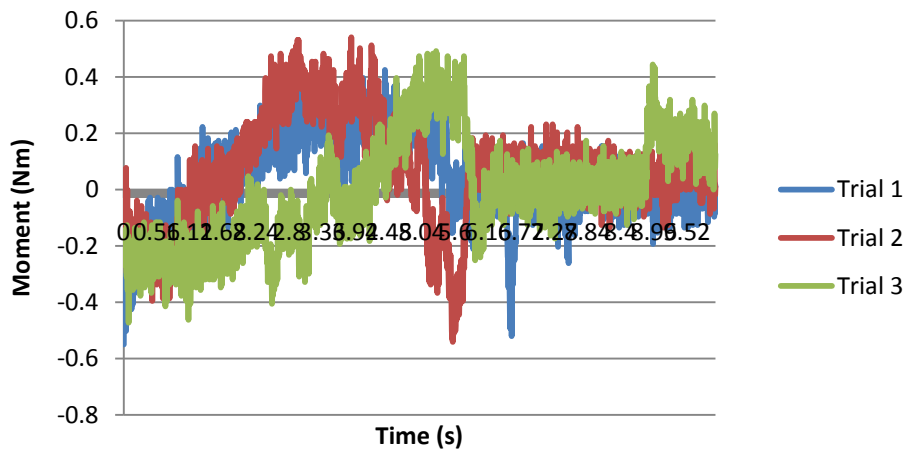

Dr. Dunn Standard Circ CCW Average Fx

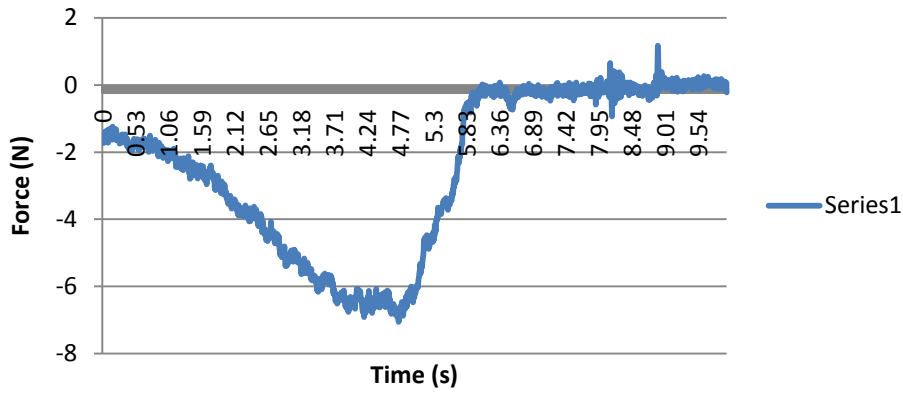

Dr. Dunn Standard Circ CCW Average Fy

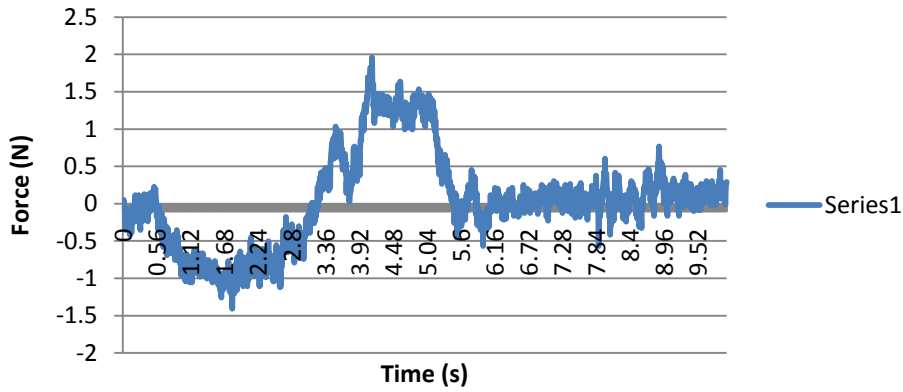

Dr. Dunn Standard Circ CCW Average Fz

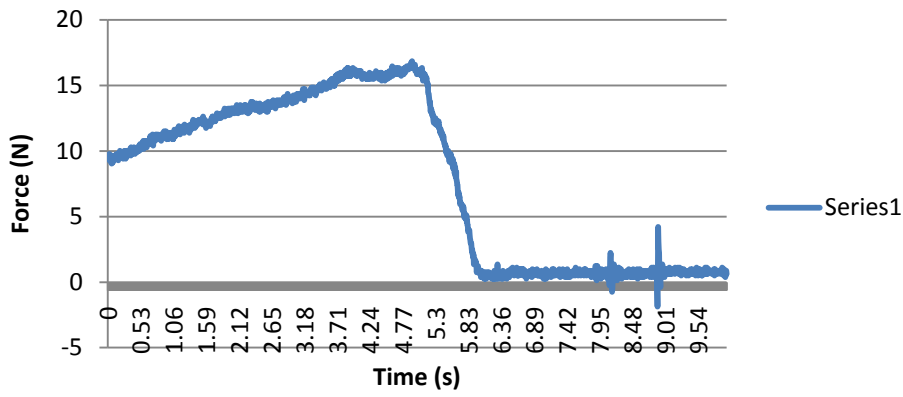

Dr. Dunn Standard Circ CCW Average Mx

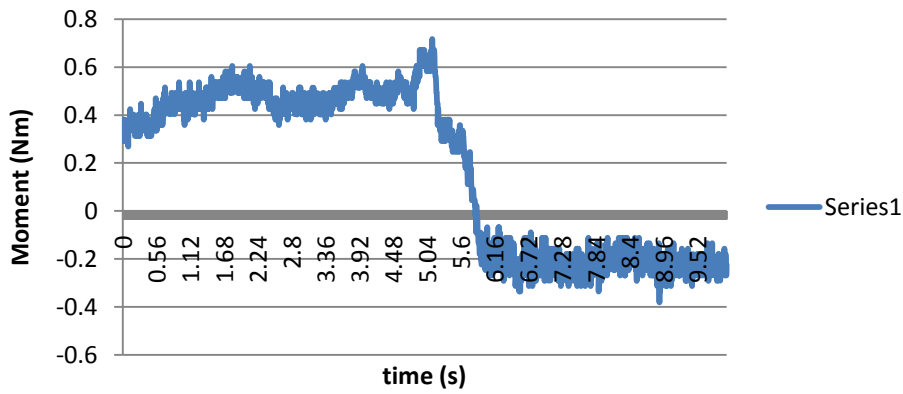

Dr. Dunn Standard Circ CCW Average My

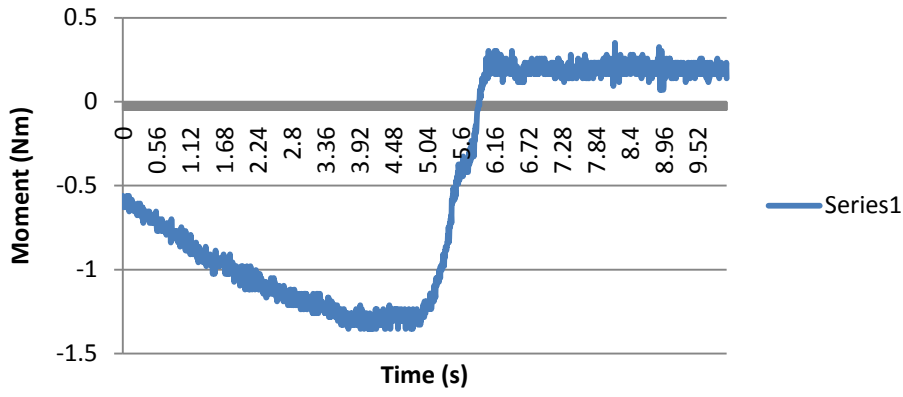

Dr. Dunn Standard Circ CCW Average Mz

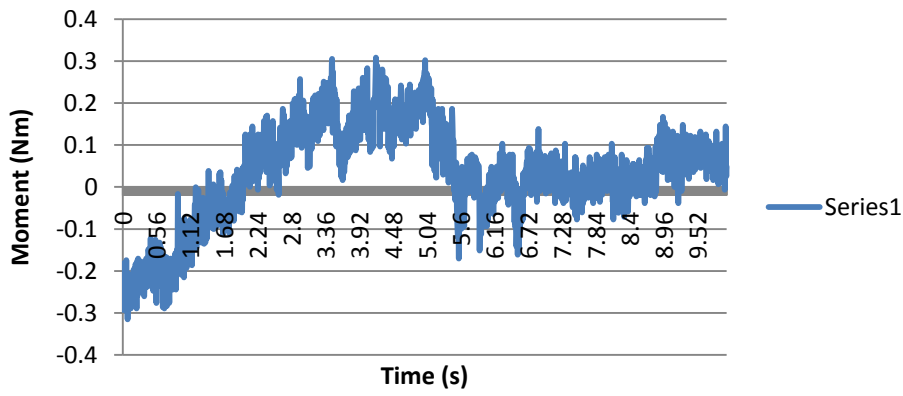

Dr. Dunn Standard Circ CW Fx

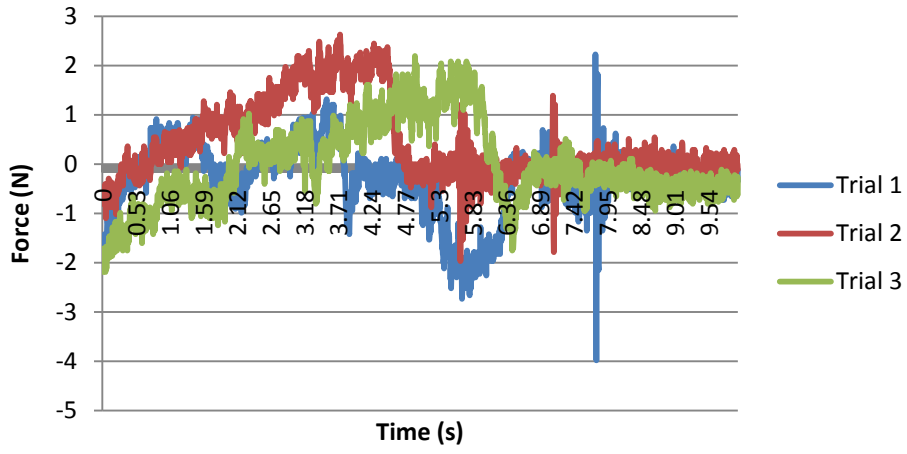

Dr. Dunn Standard Circ CW Fy

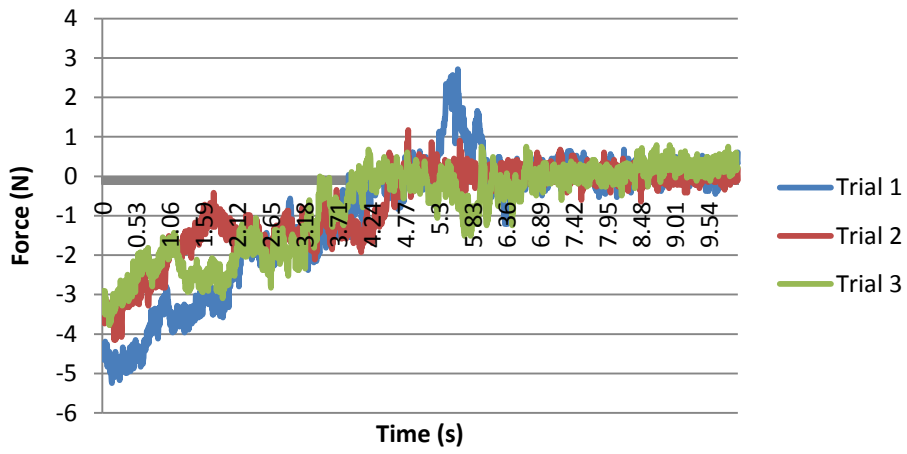

Dr. Dunn Standard Circ CW Fz

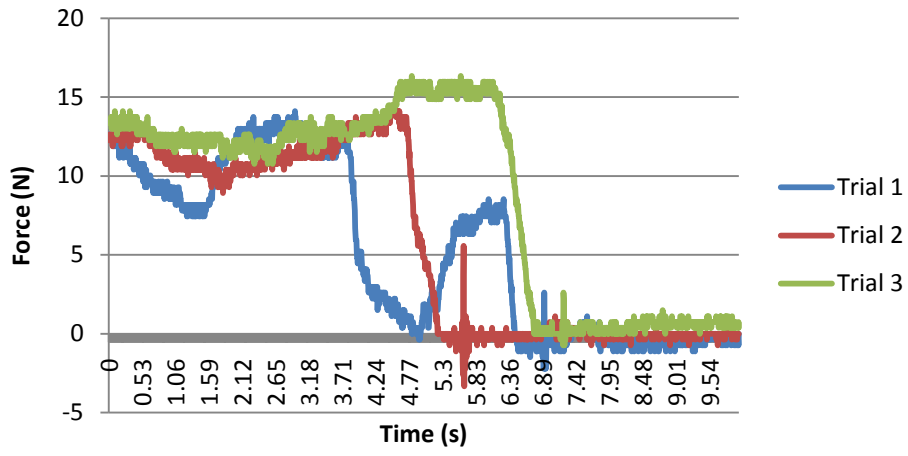

Dr. Dunn Standard Circ CW Mx

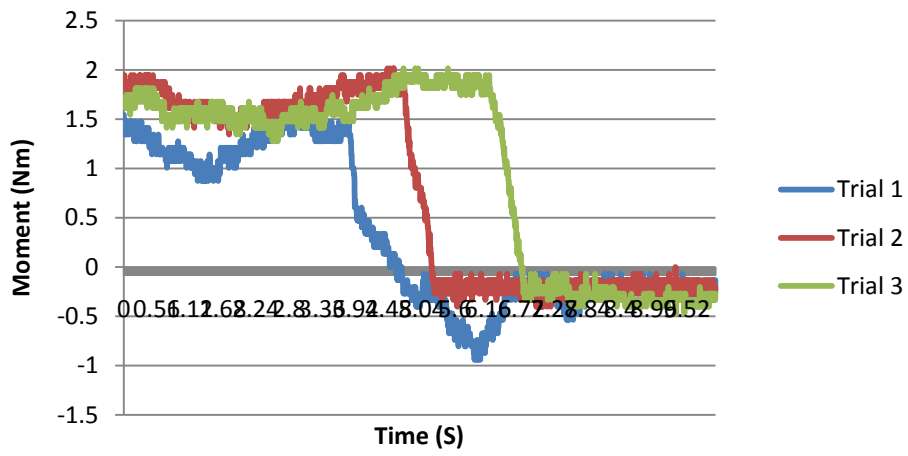

Dr. Dunn Standard Circ CW My

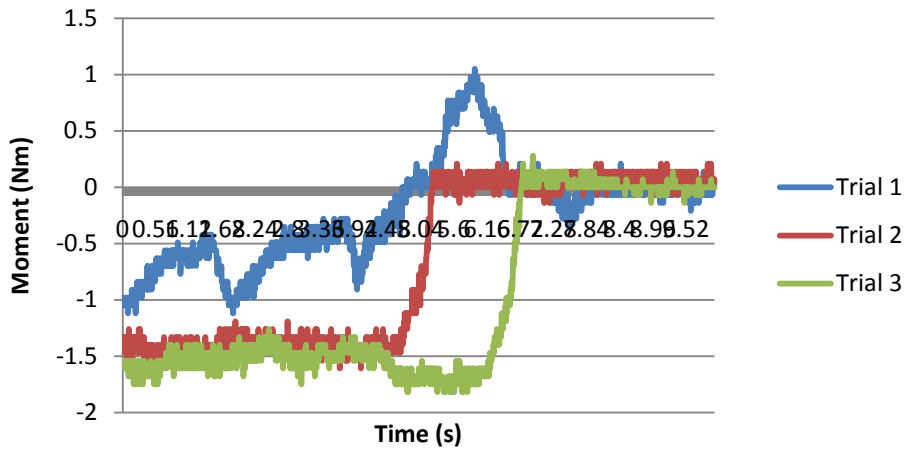

Dr. Dunn Standard Circ CW Mz

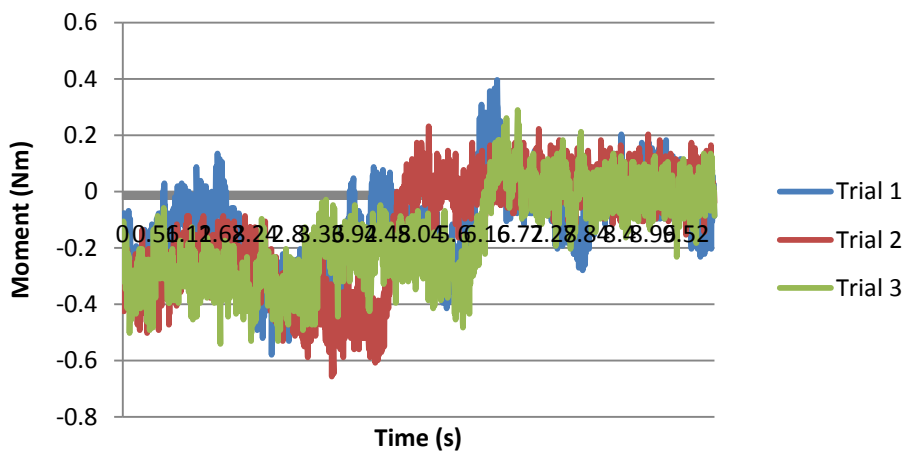

Dr. Dunn Standard Circ CW Average Fx

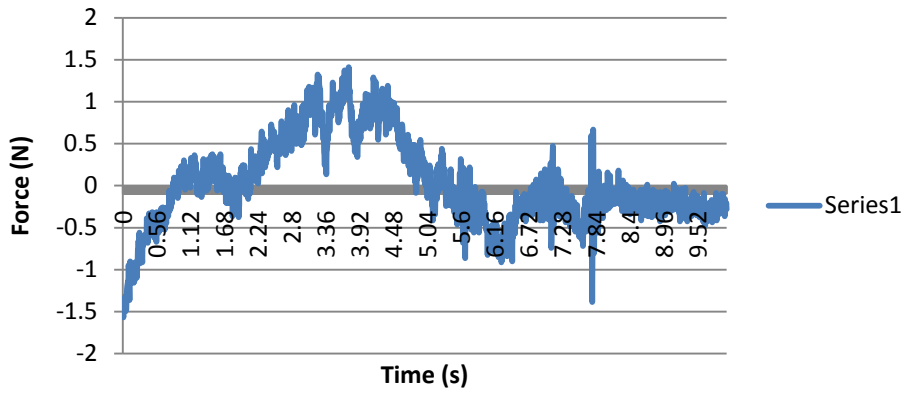

Dr. Dunn Standard Circ CW Average Fy

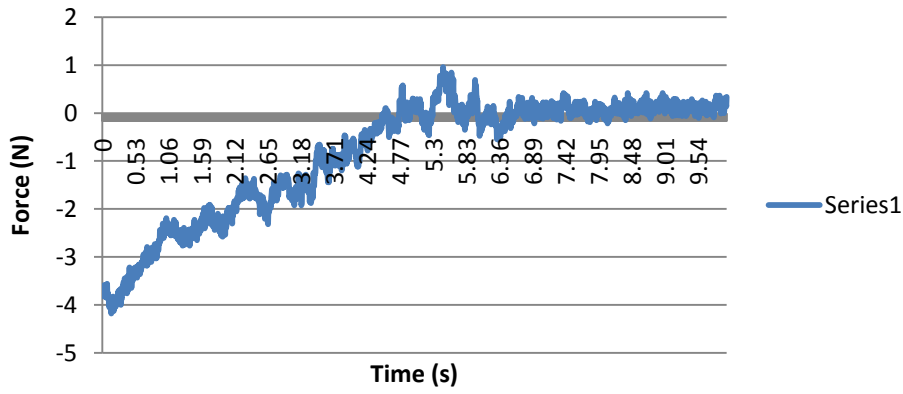

Dr. Dunn Standard Circ CW Average Fz

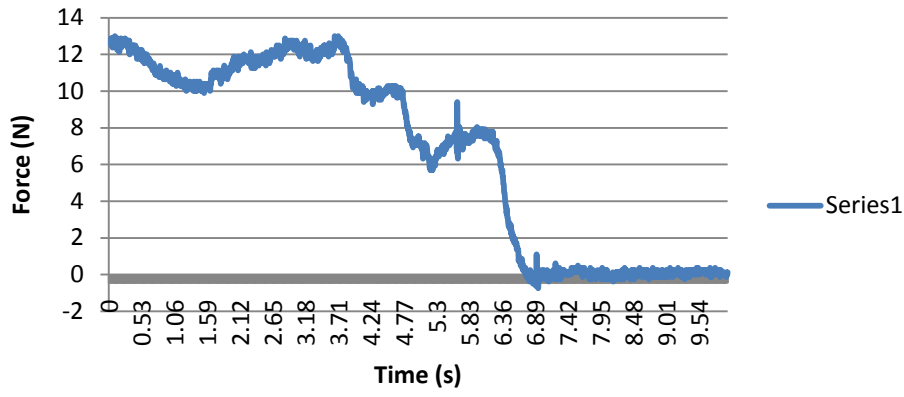

Dr. Dunn Standard Circ CW Average Mx

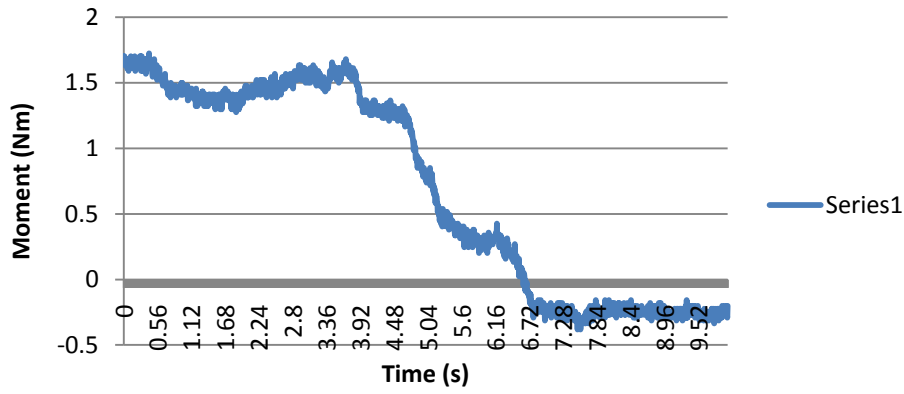

Dr. Dunn Standard Circ CW Average My

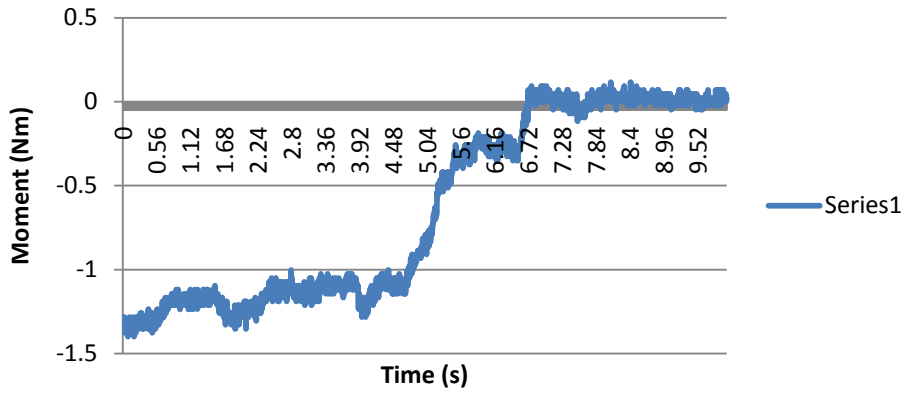

Dr. Dunn Standard Circ CW Average Mz

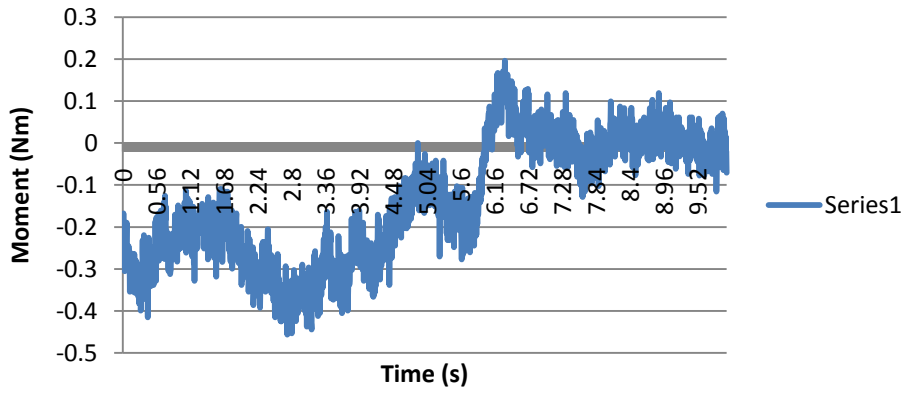

Dr. Dunn Standard Elp CCW Fx

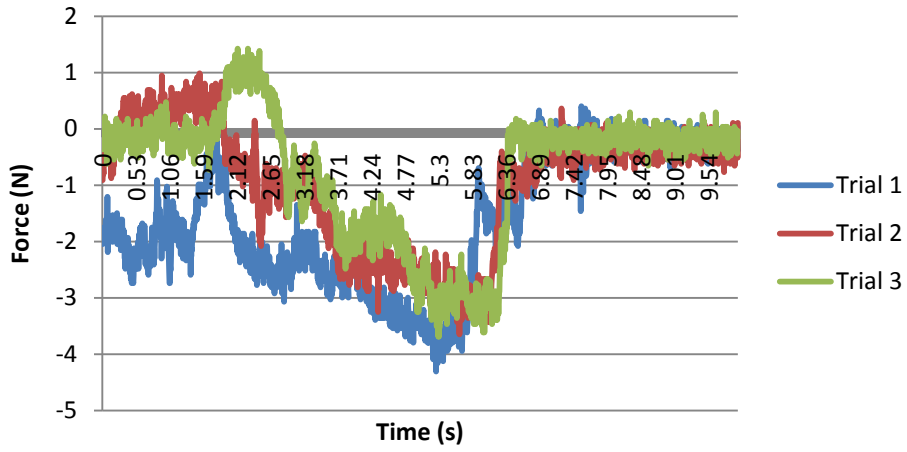

Dr. Dunn Standard Elp CCW Fy

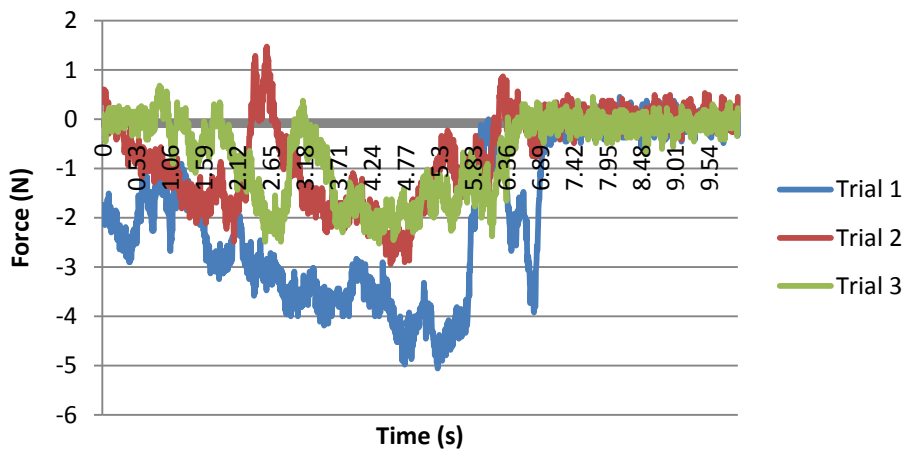

Dr. Dunn Standard Elp CCW Fz

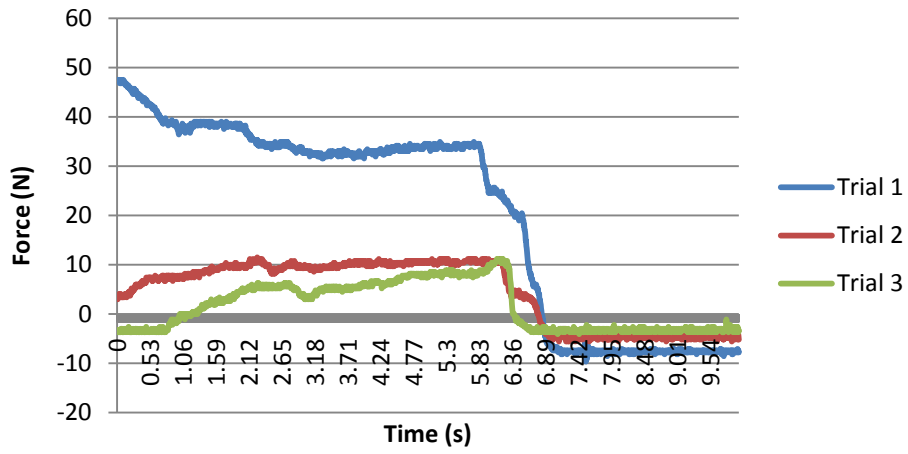

Dr. Dunn Standard Elp CCW Mx

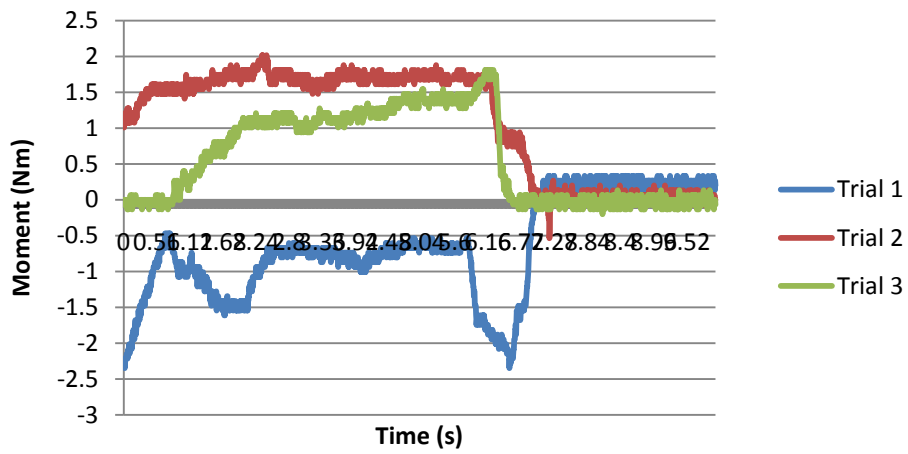

Dr. Dunn Standard Elp CCW My

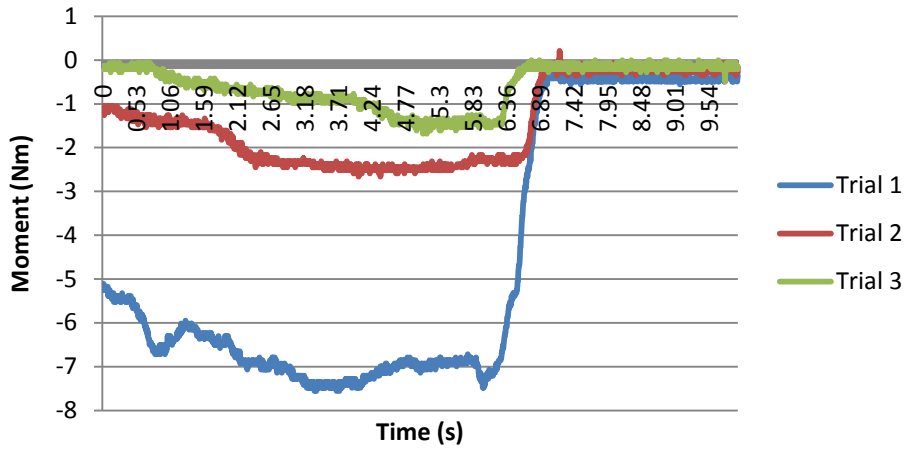

Dr. Dunn Standard Elp CCW Mz

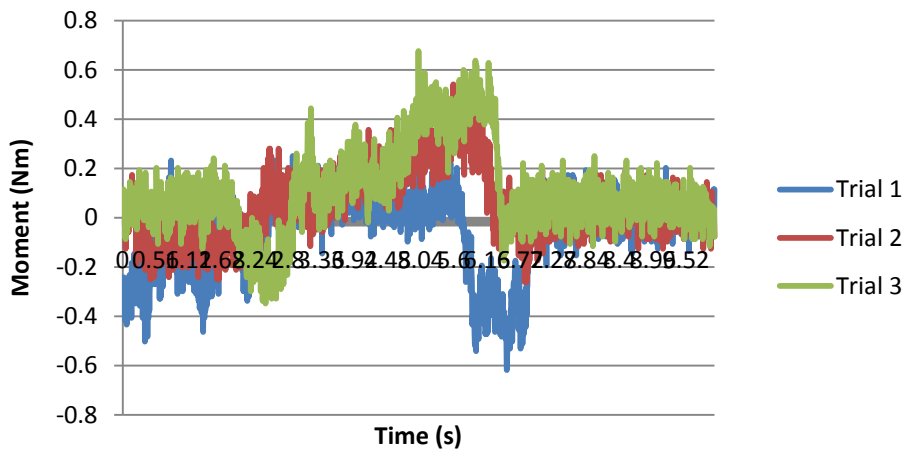

Dr. Dunn Standard Elp CCW Average Fx

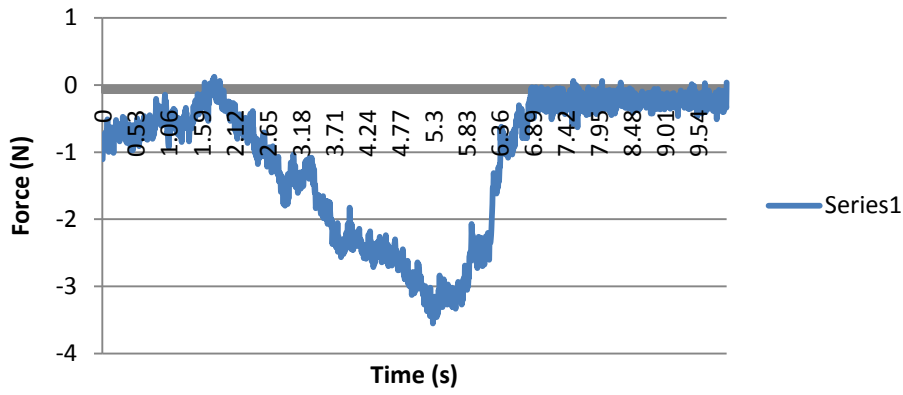

Dr. Dunn Standard Elp CCW Average Fy

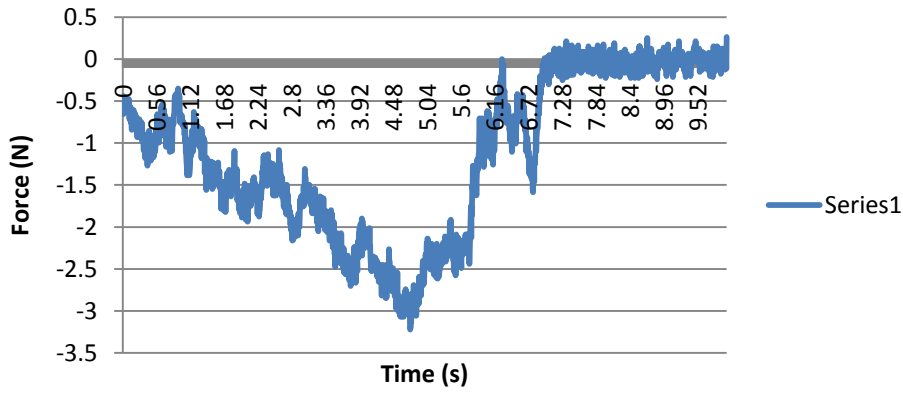

Dr. Dunn Standard Elp CCW Average Fz

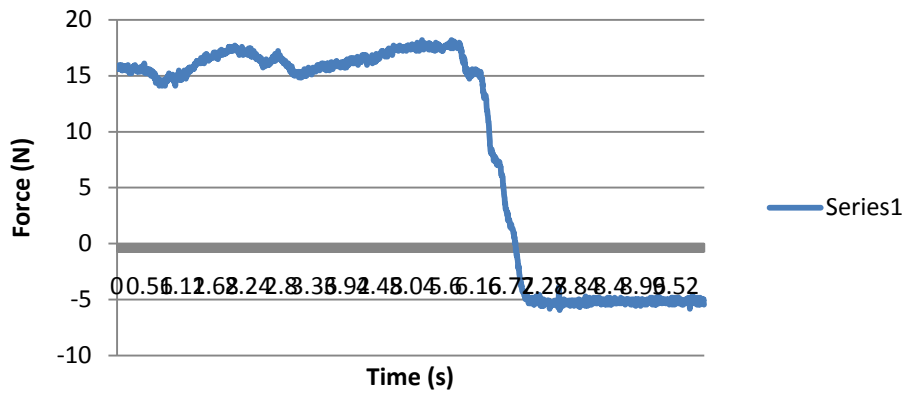

Dr. Dunn Standard Elp CCW Average Mx

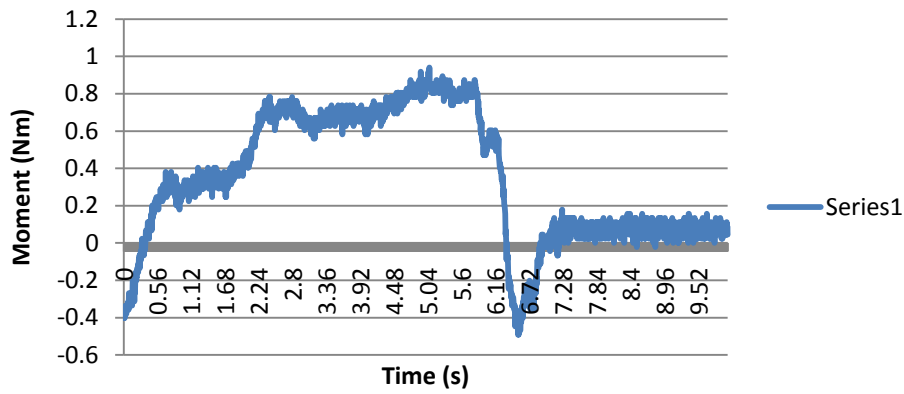

Dr. Dunn Standard Elp CCW Average My

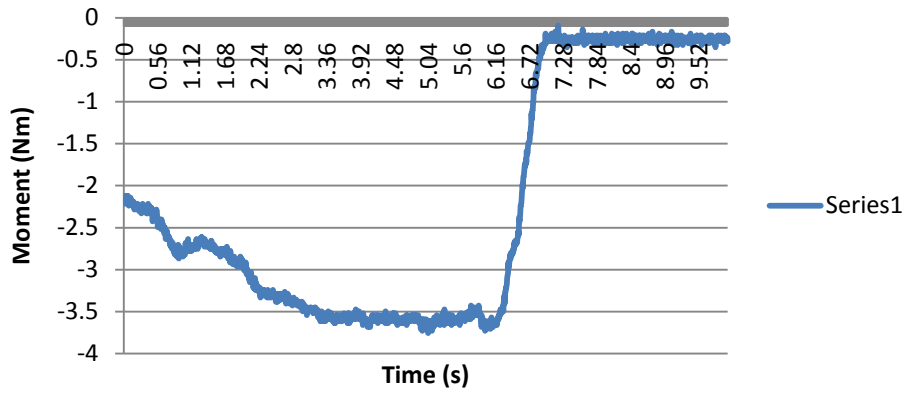

Dr. Dunn Standard Elp CCW Average Mz

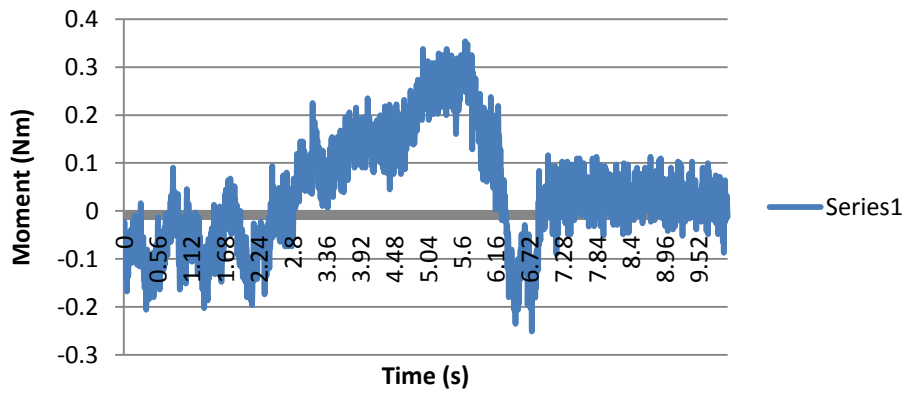

Dr Dunn Standard Elp CW Fx

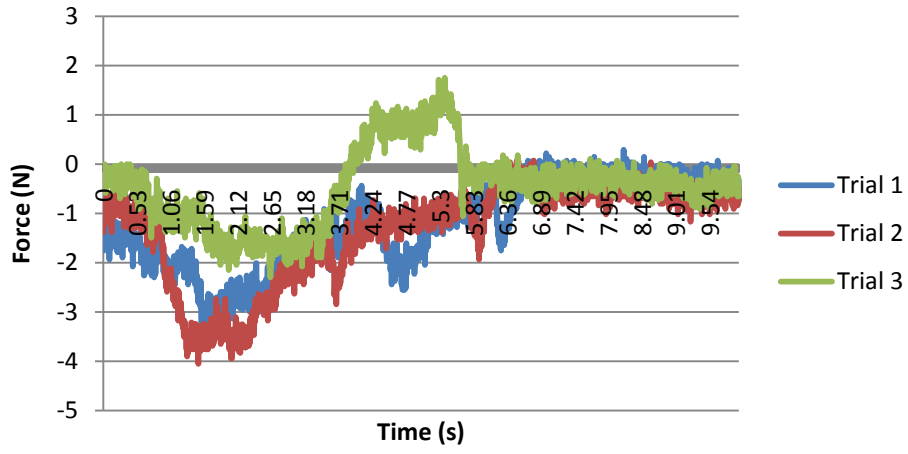

Dr Dunn Standard Elp CW Fy

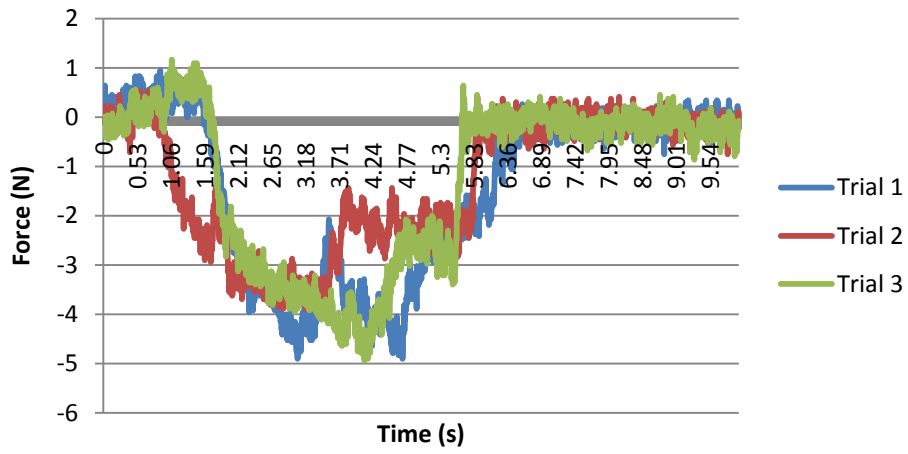

Dr Dunn Standard Elp CW Fz

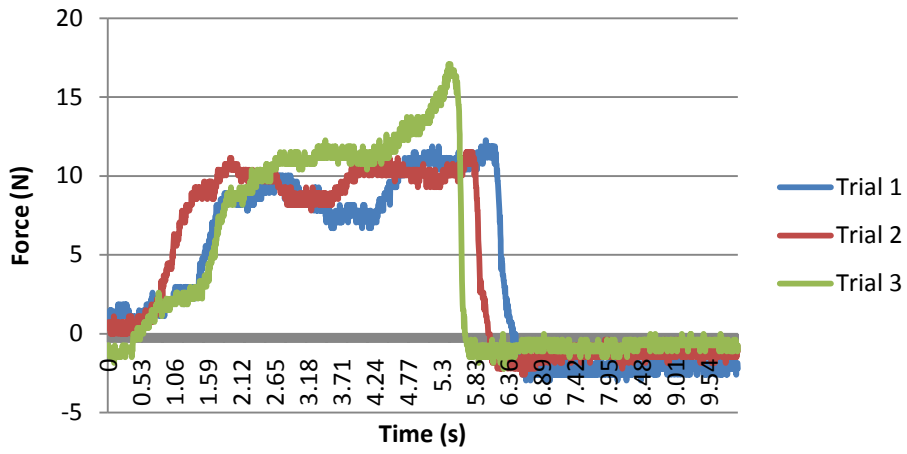

Dr Dunn Standard Elp CW Mx

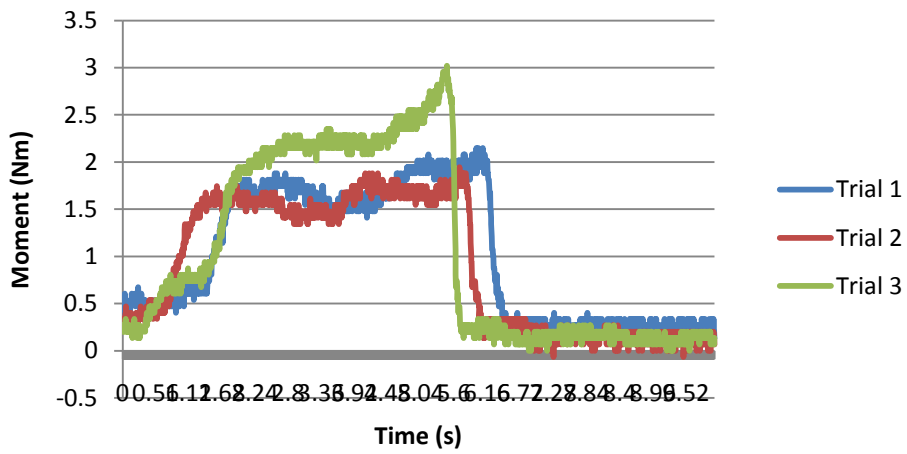

Dr Dunn Standard Elp CW My

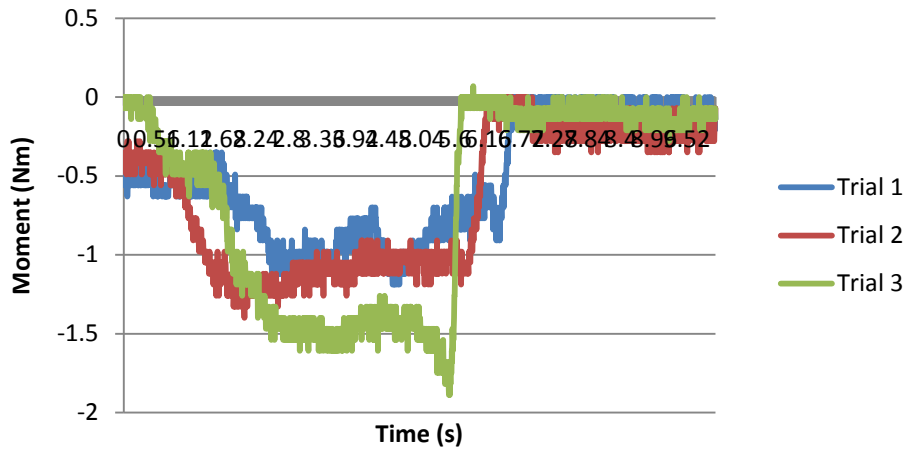

Dr Dunn Standard Elp CW Mz

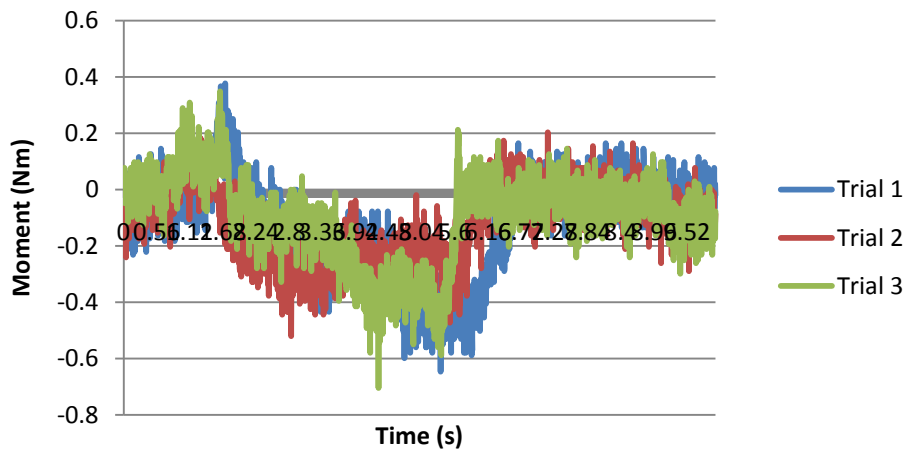

Dr Dunn Standard Elp CW Average Fx

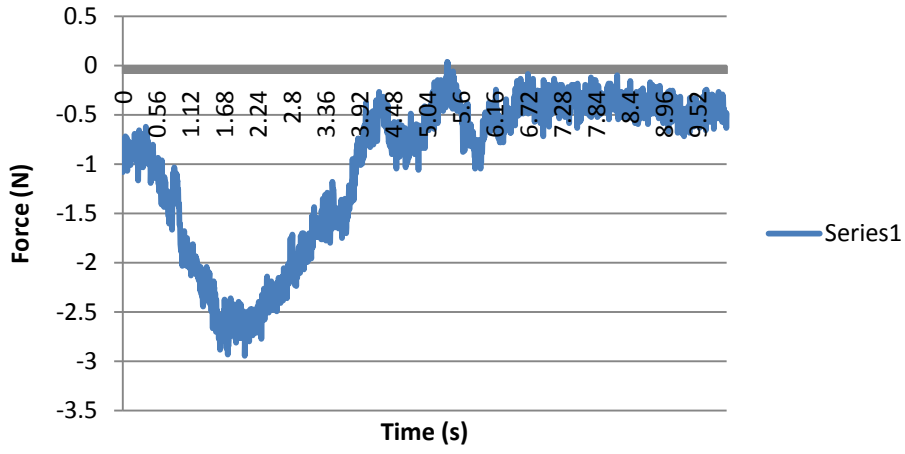

Dr Dunn Standard Elp CW Average Fy

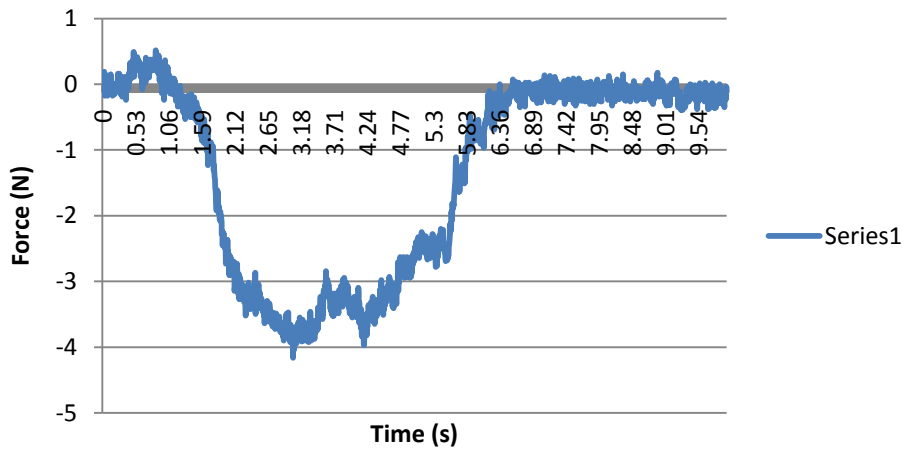

Dr Dunn Standard Elp CW Average Fz

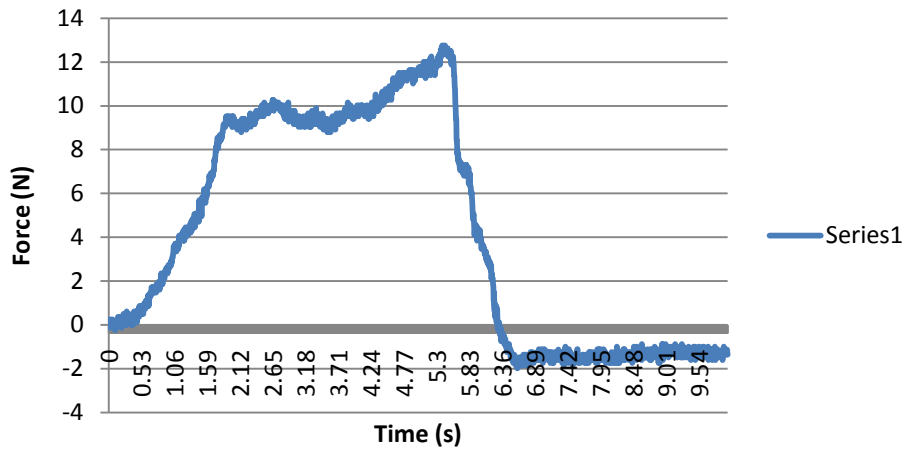

Dr Dunn Standard Elp CW Average Mx

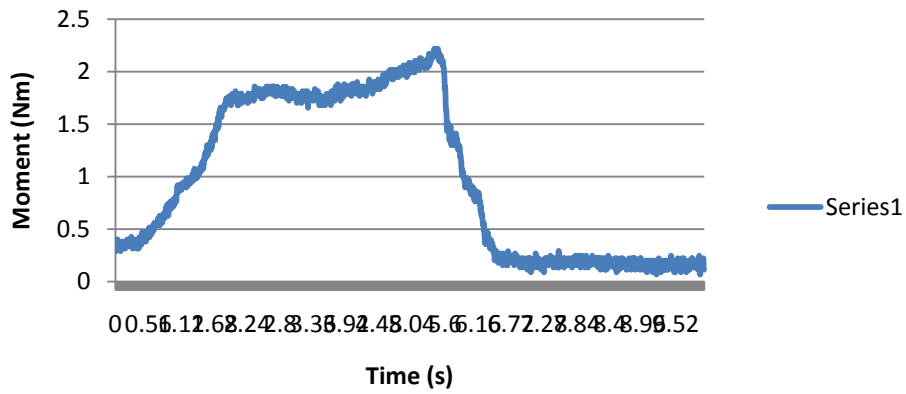

Dr Dunn Standard Elp CW Average My

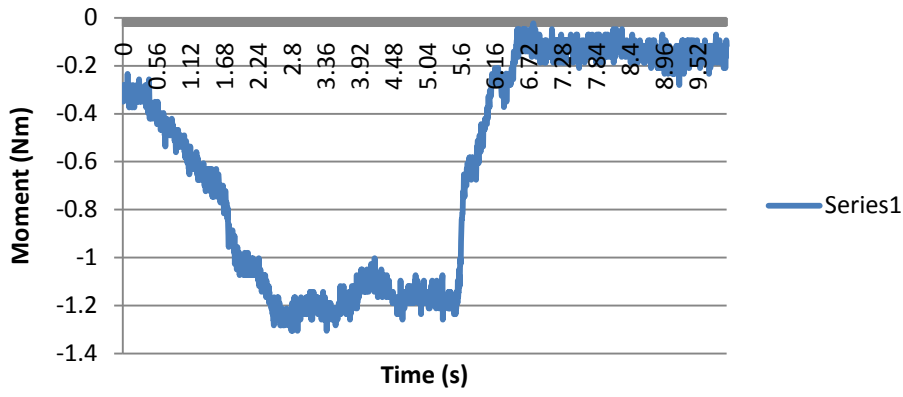

Dr Dunn Standard Elp CW Average Mz

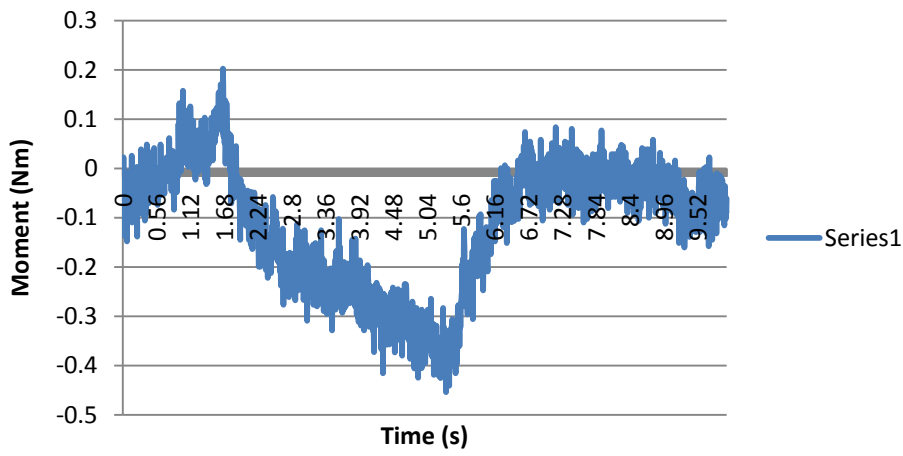

Dr Dunn Standard Horiz Linear Fx

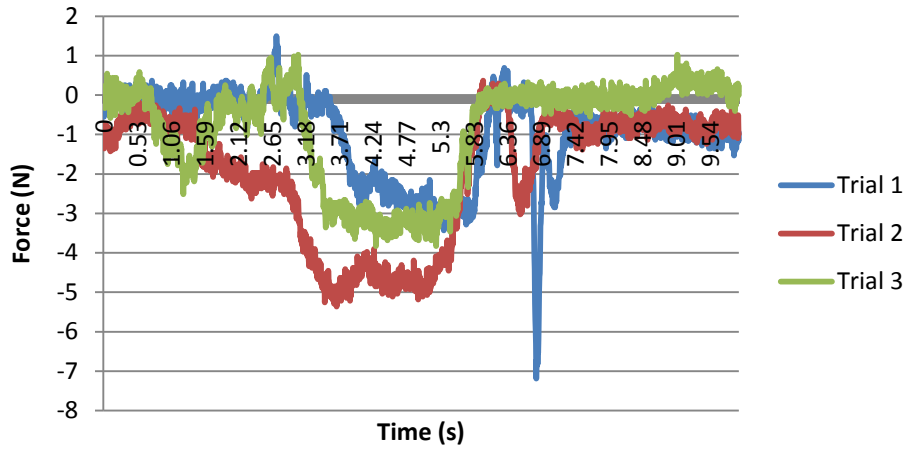

Dr Dunn Standard Horiz Linear Fy

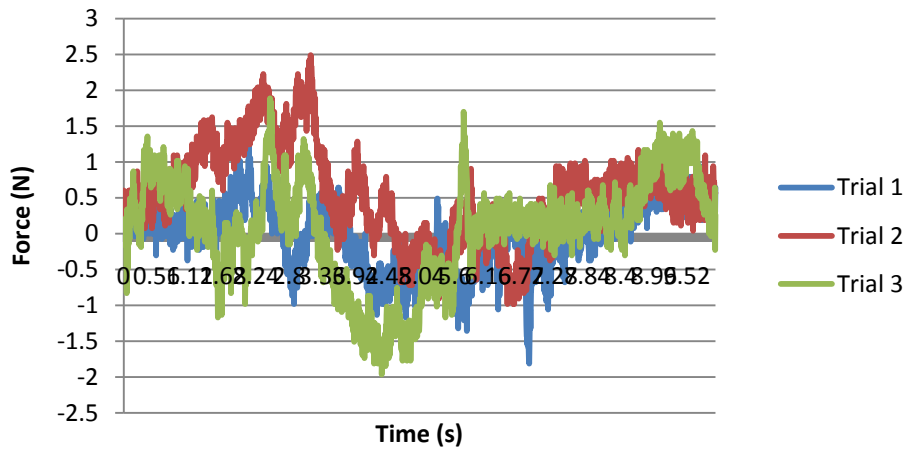

Dr Dunn Standard Horiz Linear Fz

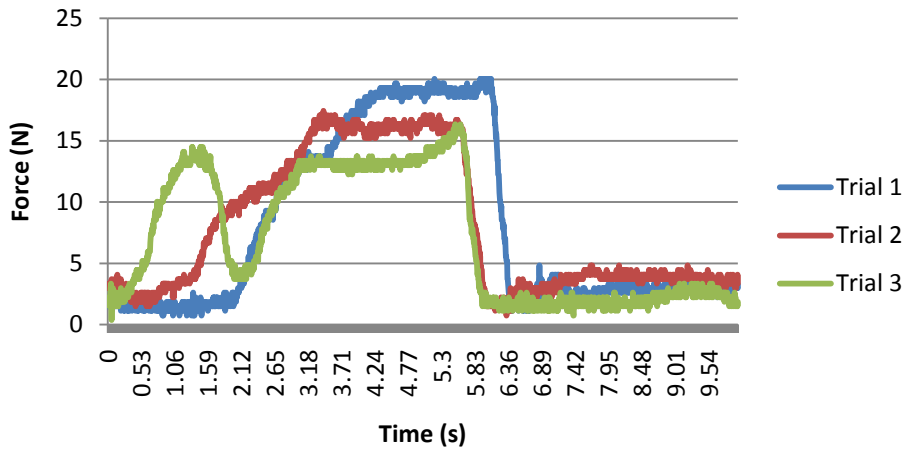

Dr Dunn Standard Horiz Linear Mx

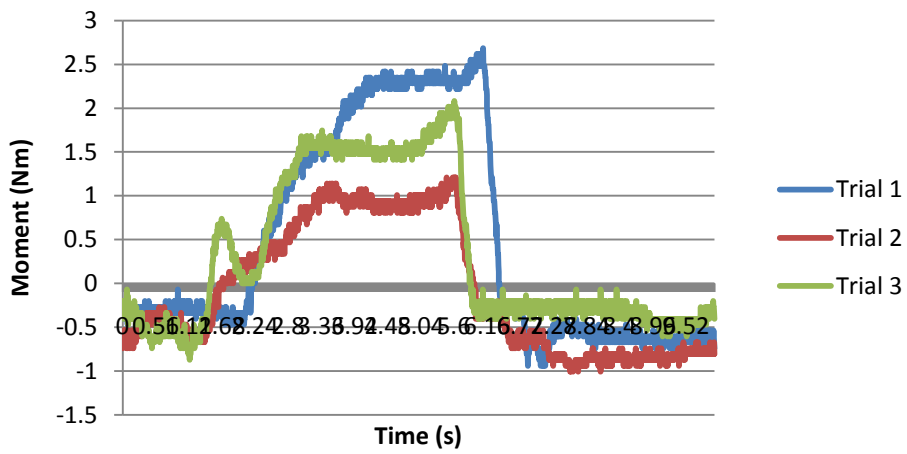

Dr Dunn Standard Horiz Linear My

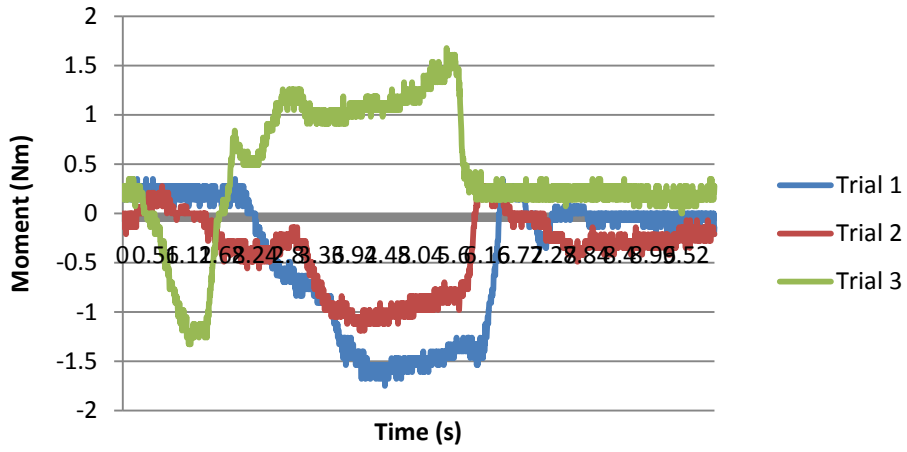

Dr Dunn Standard Horiz Linear Mz

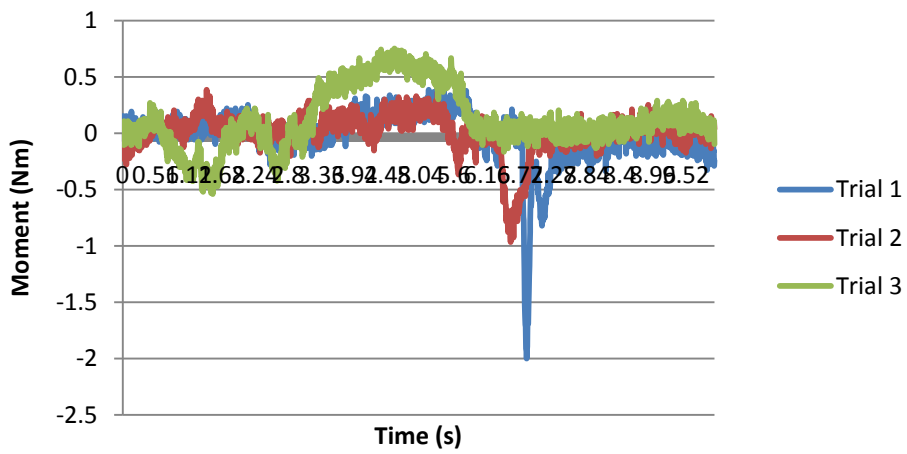

Dr Dunn Standard Horiz Linear Average Fx

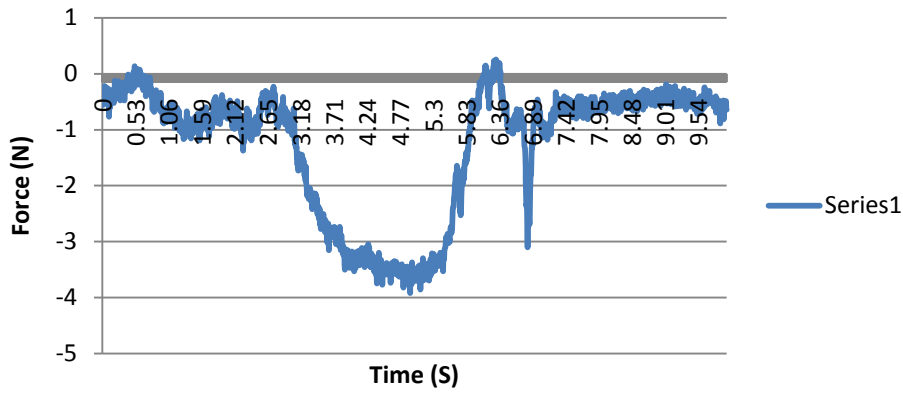

Dr Dunn Standard Horiz Linear Average Fy

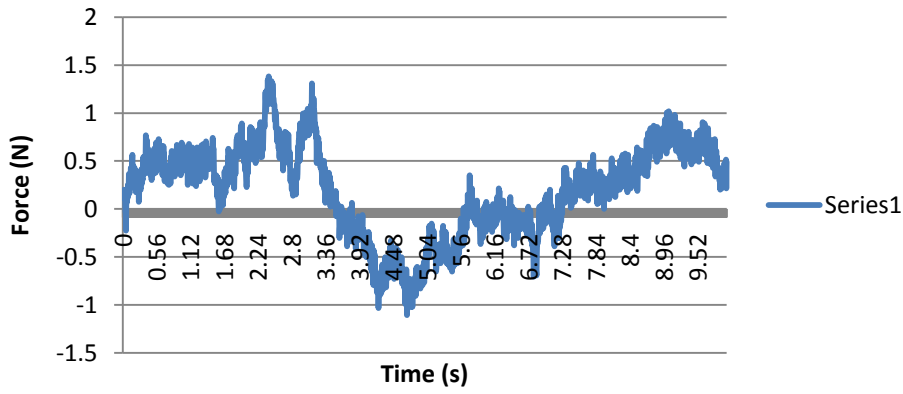

Dr Dunn Standard Horiz Linear Average Fz

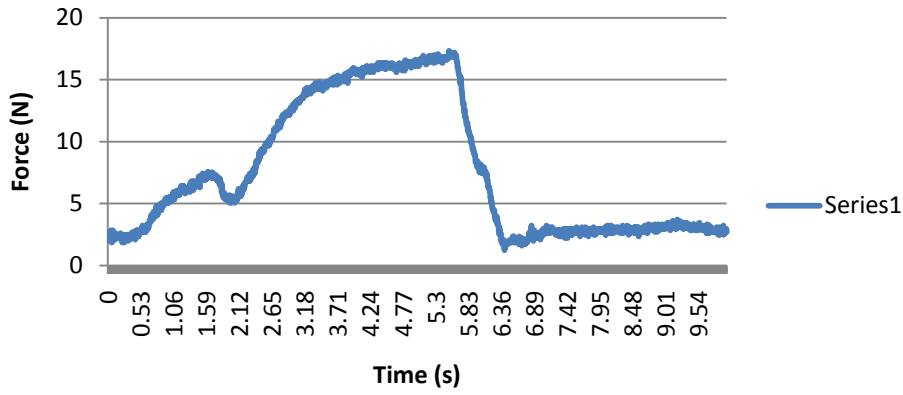

Dr Dunn Standard Horiz Linear Average Mx

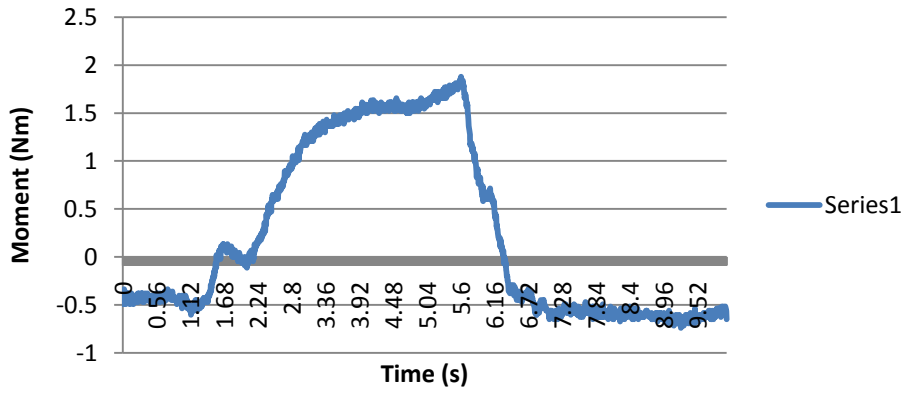

Dr Dunn Standard Horiz Linear Average My

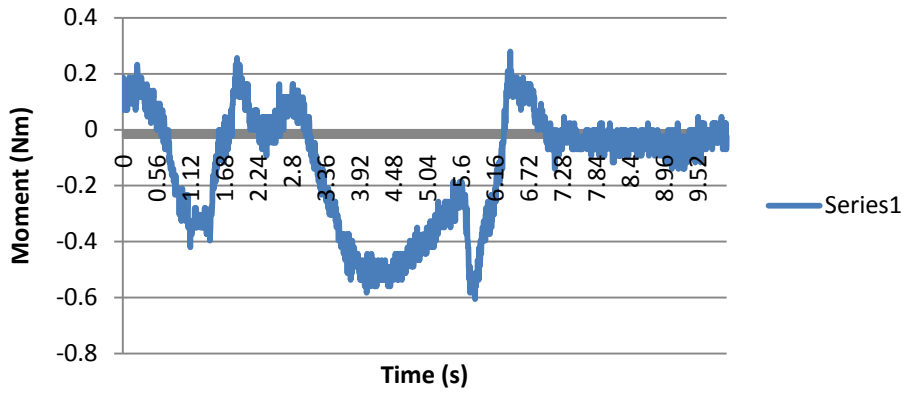

Dr Dunn Standard Horiz Linear Average Mz

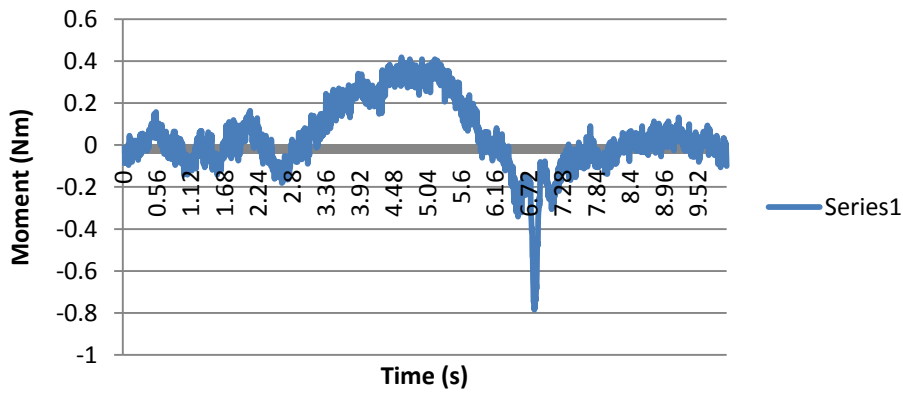

Dr Dunn Standard Vert Linear Fx

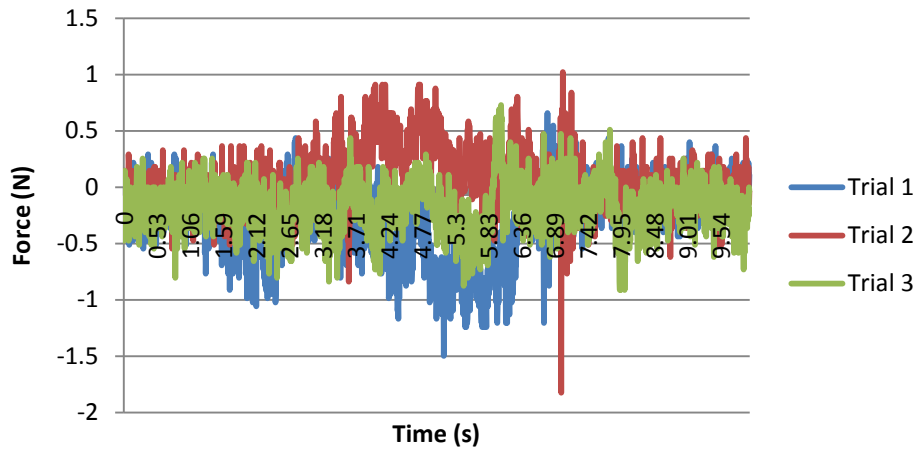

Dr Dunn Standard Vert Linear Fy

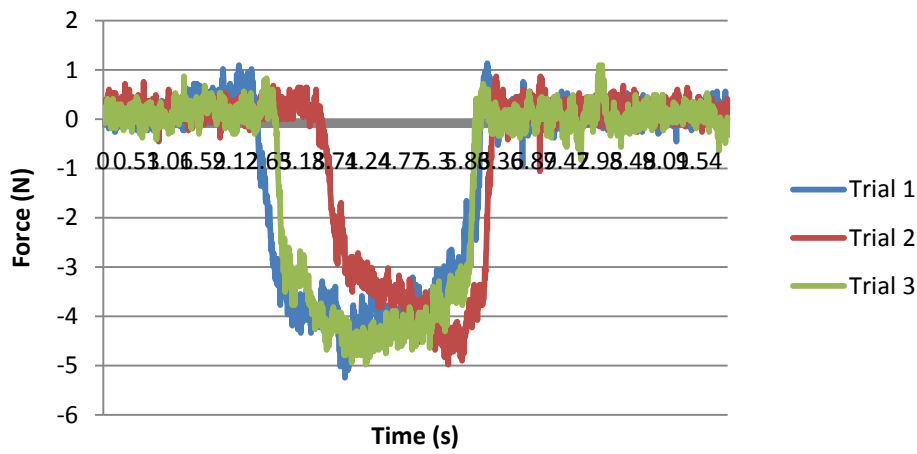

Dr Dunn Standard Vert Linear Fz

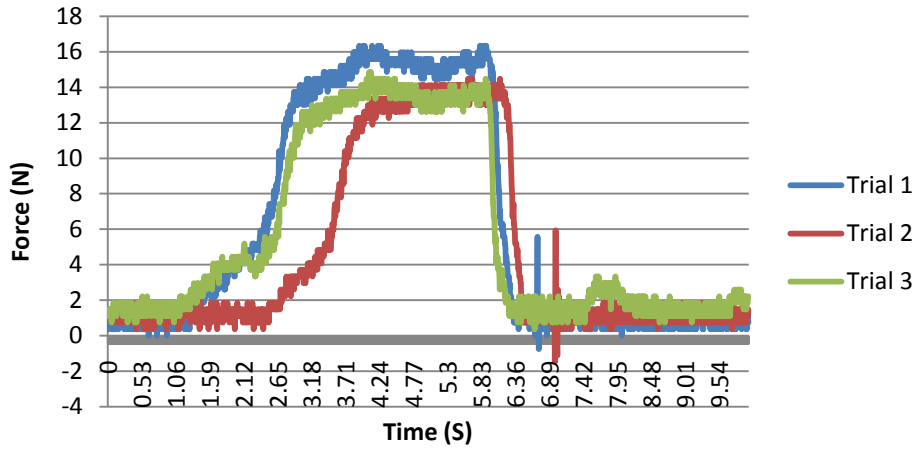

Dr Dunn Standard Vert Linear Mx

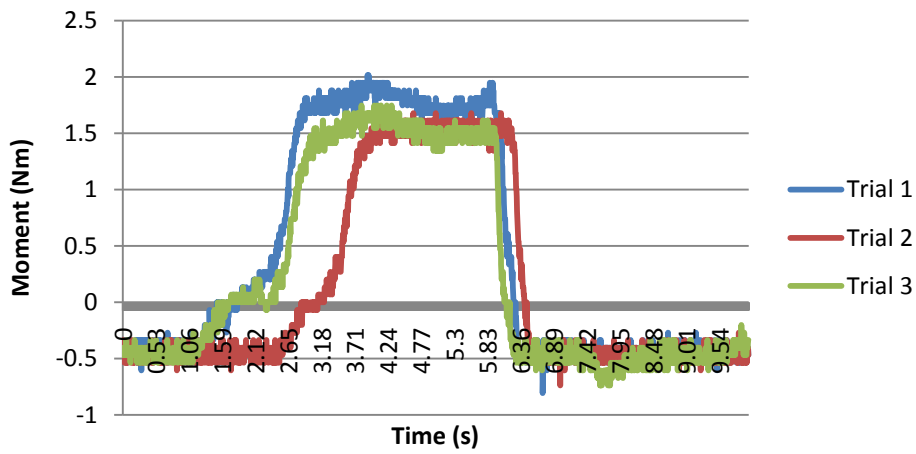

Dr Dunn Standard Vert Linear My

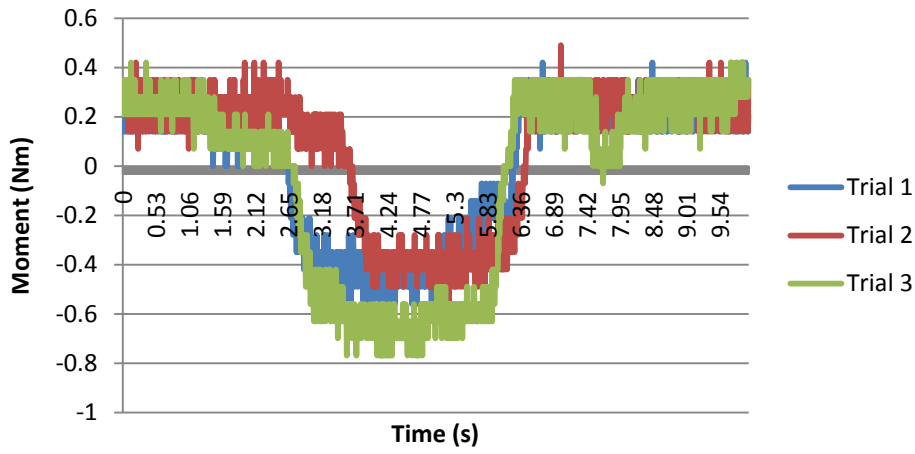

Dr Dunn Standard Vert Linear Mz

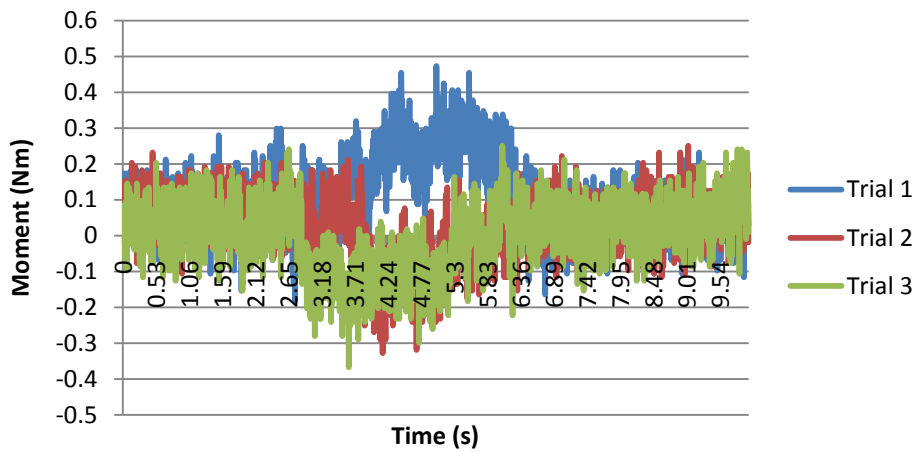

Dr Dunn Standard Vert Linear Average Fx

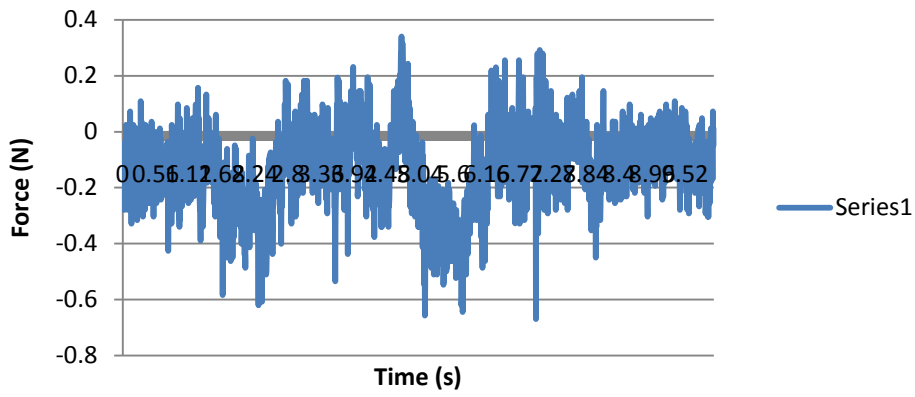

Dr Dunn Standard Vert Linear Average Fy

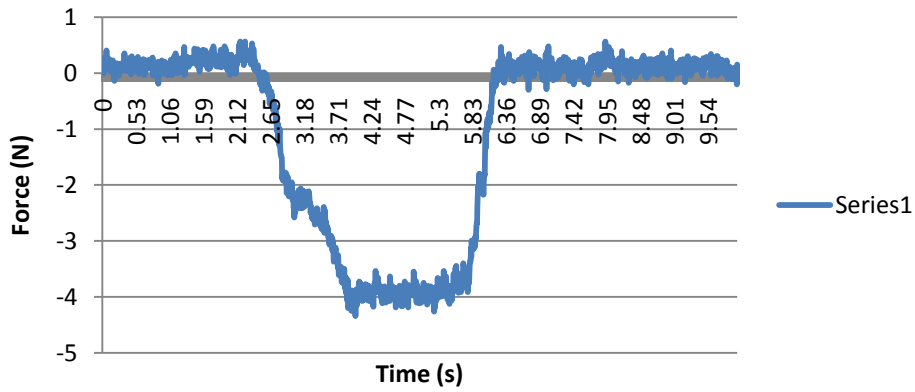

Dr Dunn Standard Vert Linear Average Fz

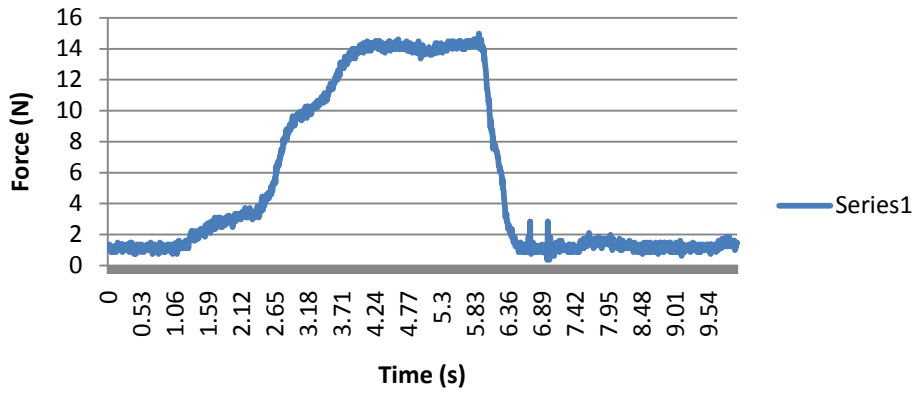

Dr Dunn Standard Vert Linear Average Mx

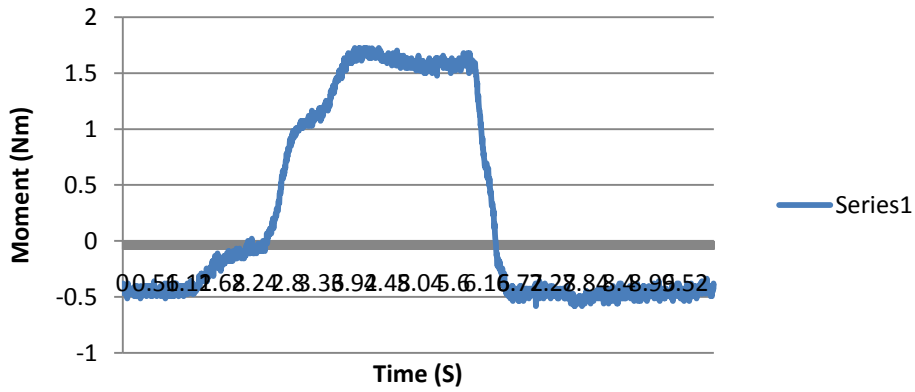

Dr Dunn Standard Vert Linear Average My

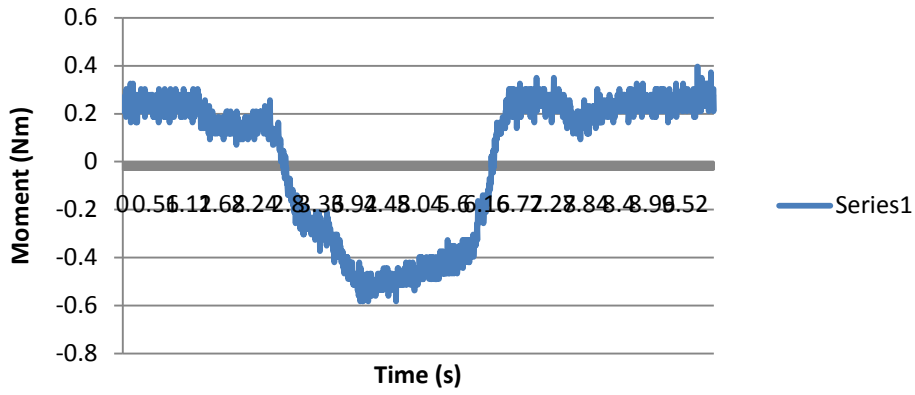

Dr Dunn Standard Vert Linear Average Mz

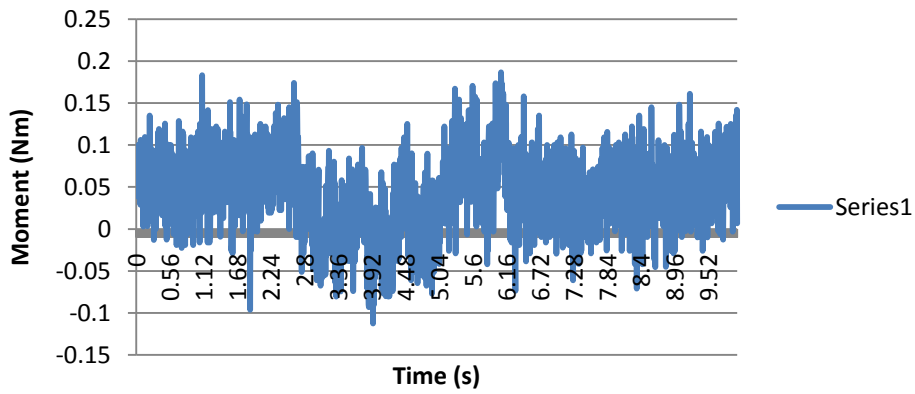

Fx for Large Handle: Counterclockwise Circular Incision

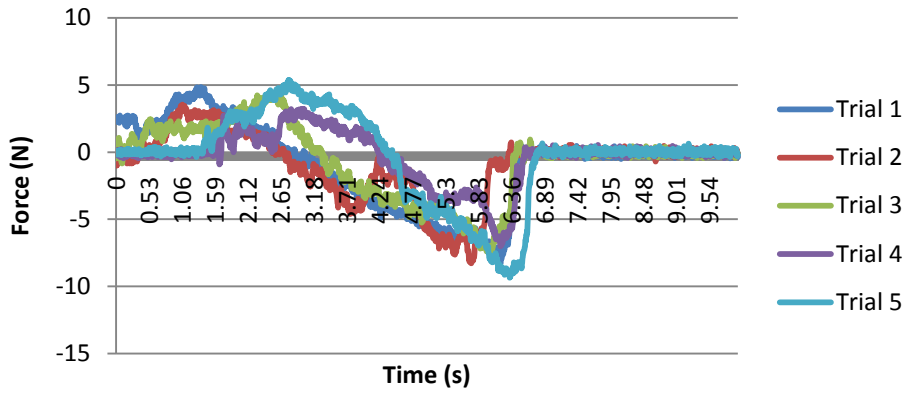

Fy for Large Handle: Counterclockwise Circular Incision

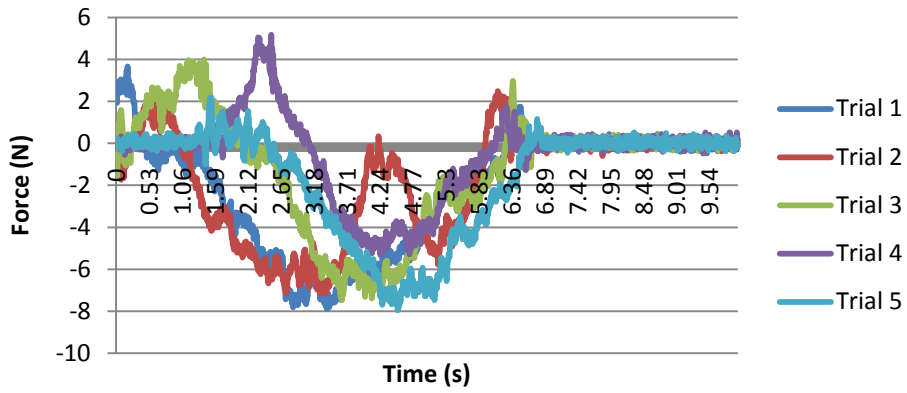

Fz for Large Handle: Counterclockwise Circular Incision

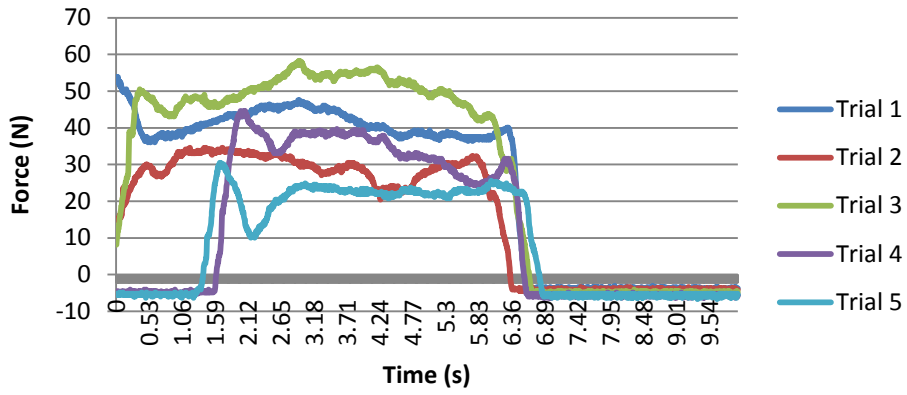

Mx for Large Handle: Counterclockwise Circular Incision

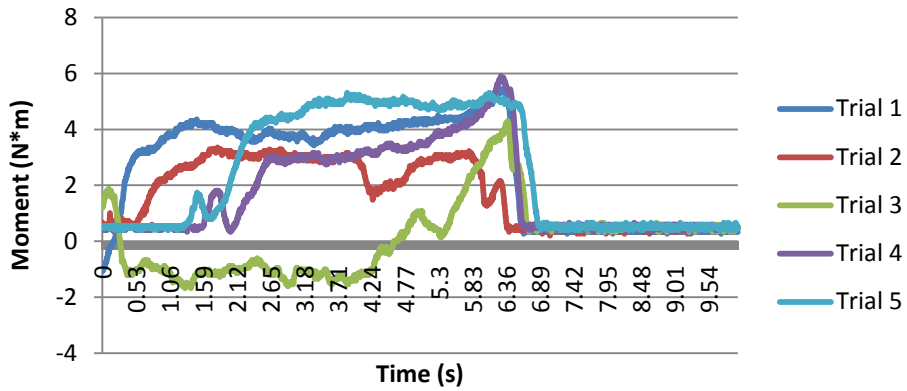

My for Large Handle: Counterclockwise Circular Incision

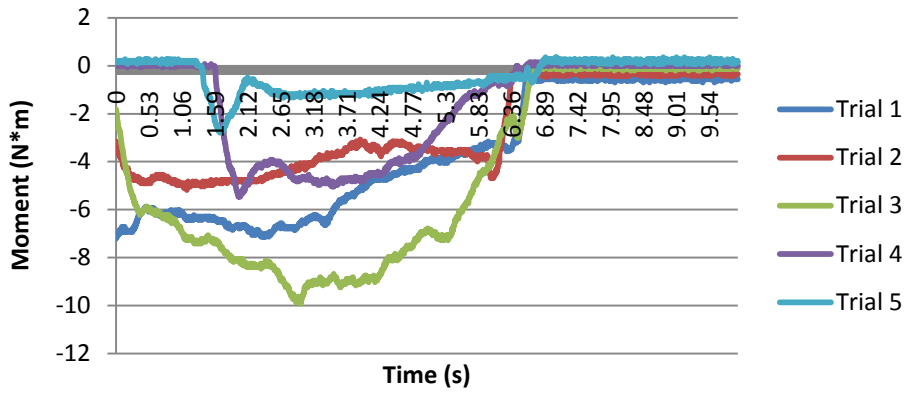

Mz for Large Handle: Counterclockwise Circular Incision

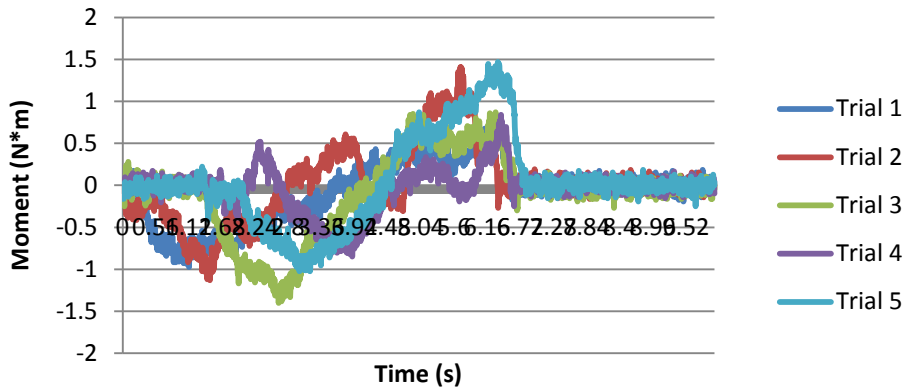

Average Fx for Large Handle: Counterclockwise Circular Incision

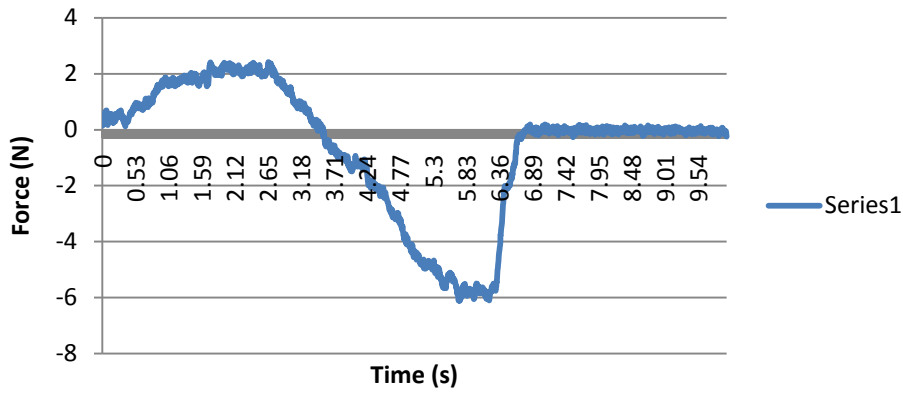

Average Fy for Large Handle: Counterclockwise Circular Incision

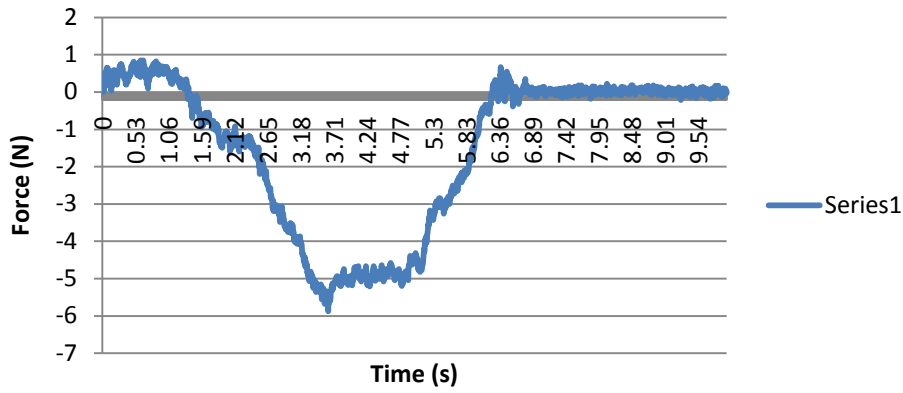

Average Fz for Large Handle: Counterclockwise Circular Incision

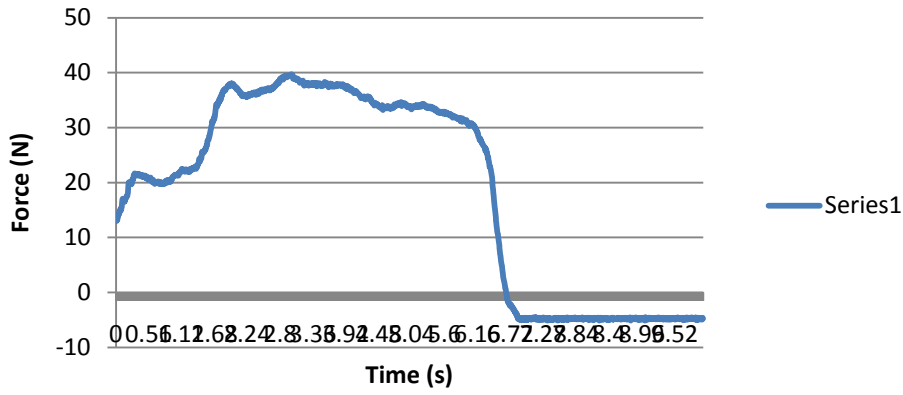

Average Mx for Large Handle: Counterclockwise Circular Incision

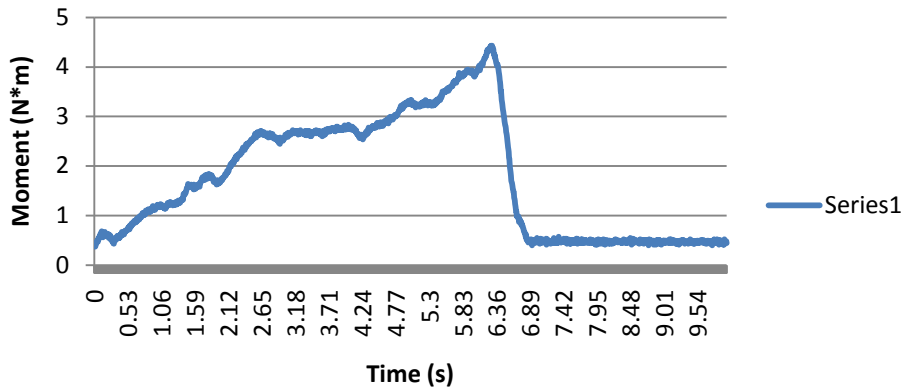

Average Mx for Large Handle: Counterclockwise Circular Incision

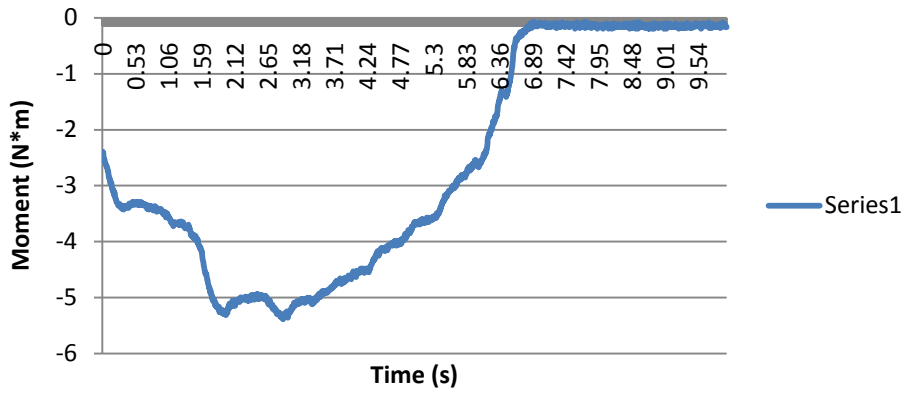

Average Mz for Large Handle: Counterclockwise Circular Incision

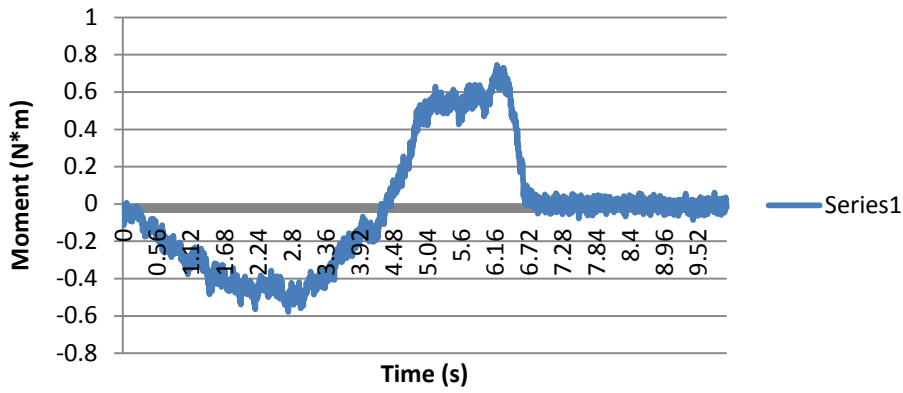

Fx for Large Handle: Clockwise Circular Incision

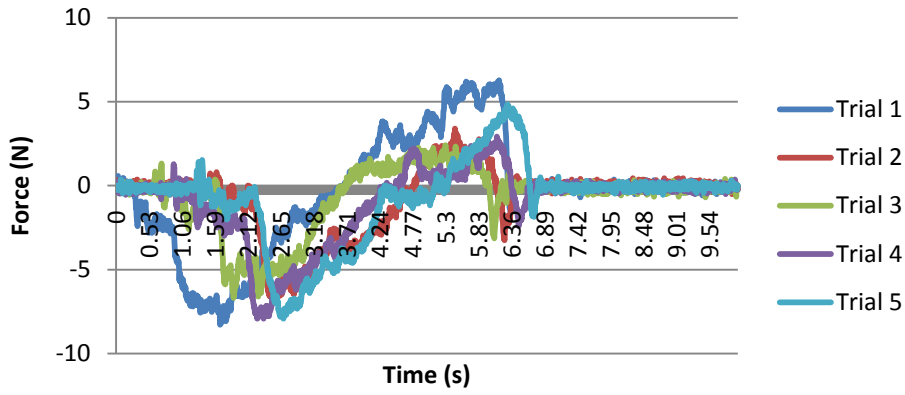

Fy for Large Handle: Clockwise Circular Incision

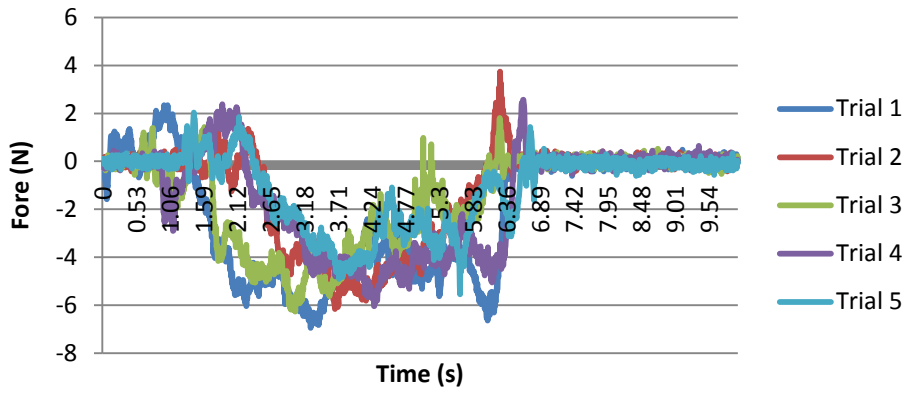

Fz for Large Handle: Clockwise Circular Incision

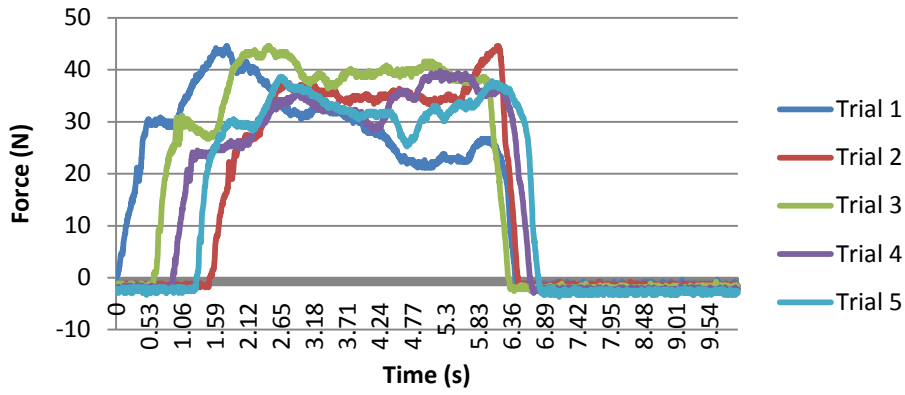

Mx for Large Handle: Clockwise Circular Incision

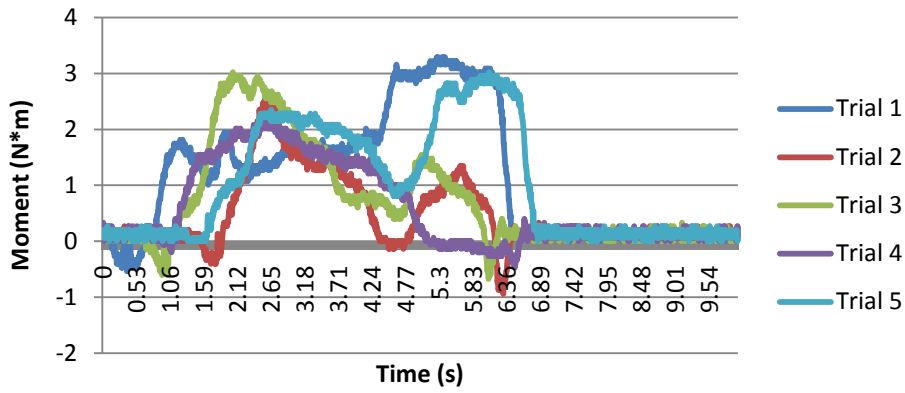

My for Large Handle: Clockwise Circular Incision

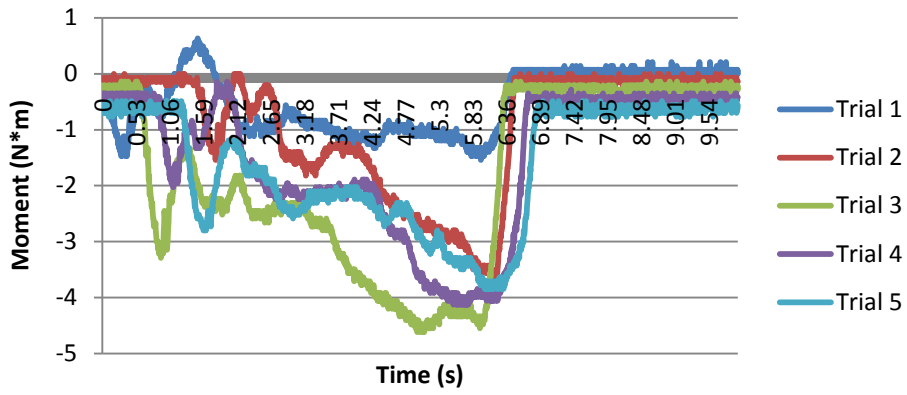

Mz for Large Handle: Clockwise Circular Incision

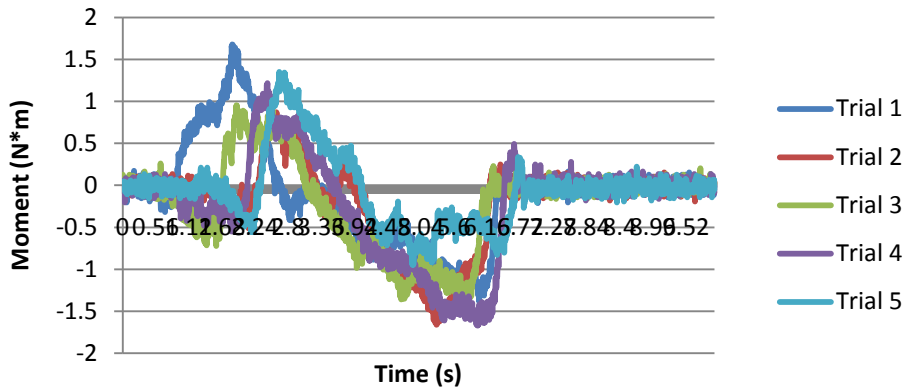

Average Fx for Large Handle: Clockwise Circular Incision

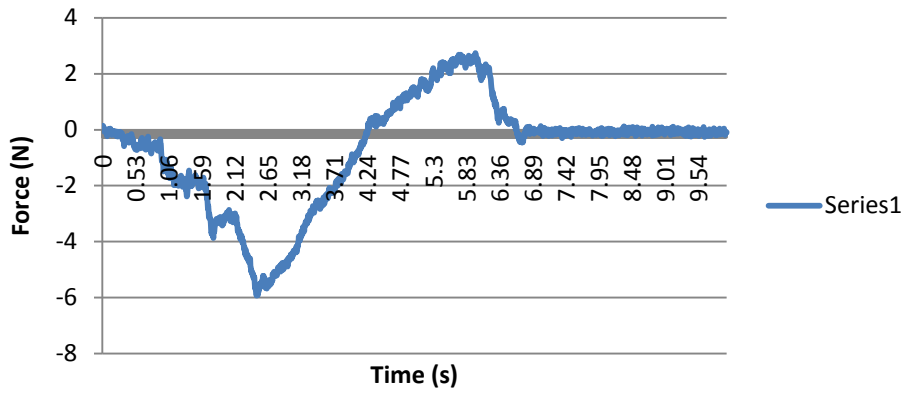

Average Fy for Large Handle: Clockwise Circular Incision

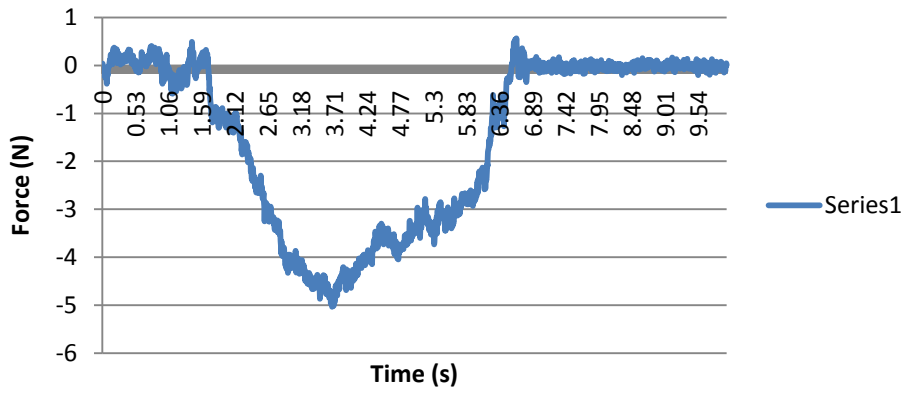

Average Fz for Large Handle: Clockwise Circular Incision

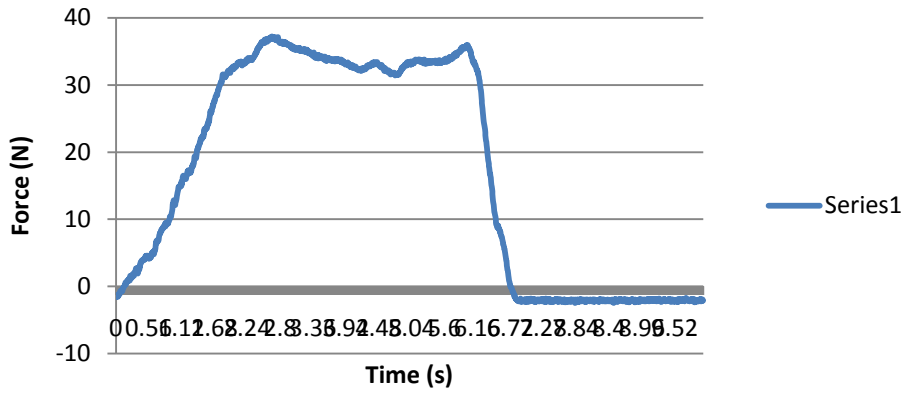

Average Mx for Large Handle: Clockwise Circular Incision

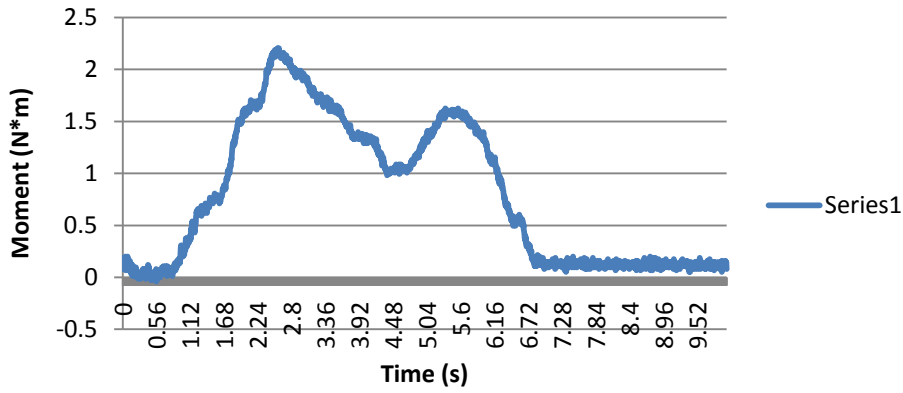

Average My for Large Handle: Clockwise Circular Incision

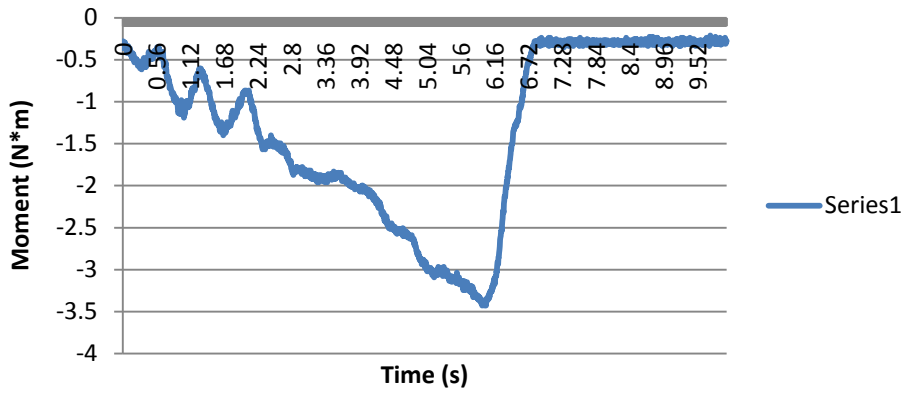

Average Mz for Large Handle: Clockwise Circular Incision

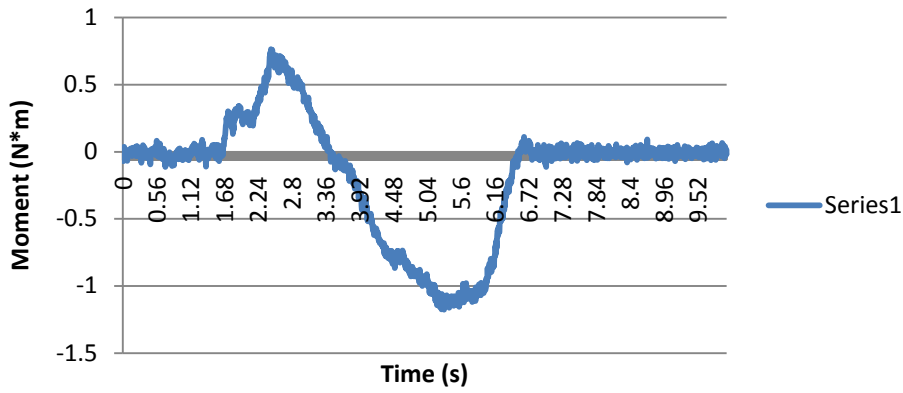

Fx for Large Handle: Counterclockwise Elliptical Incision

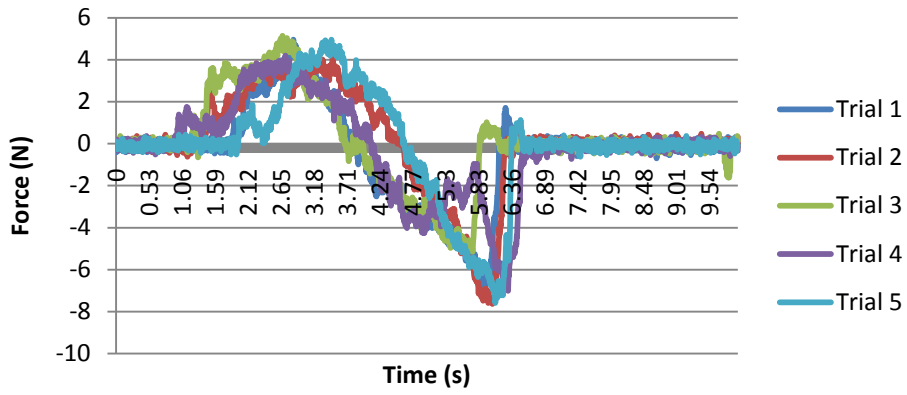

Fx for Large Handle: Counterclockwise Elliptical Incision

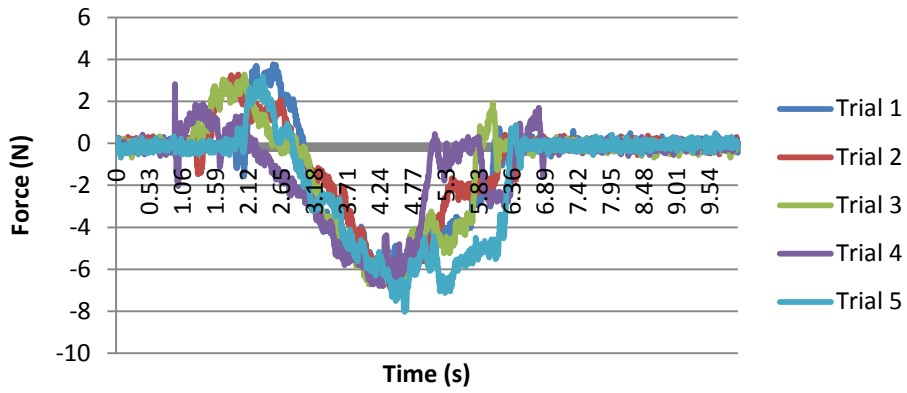

Fz for Large Handle: Counterclockwise Elliptical Incision

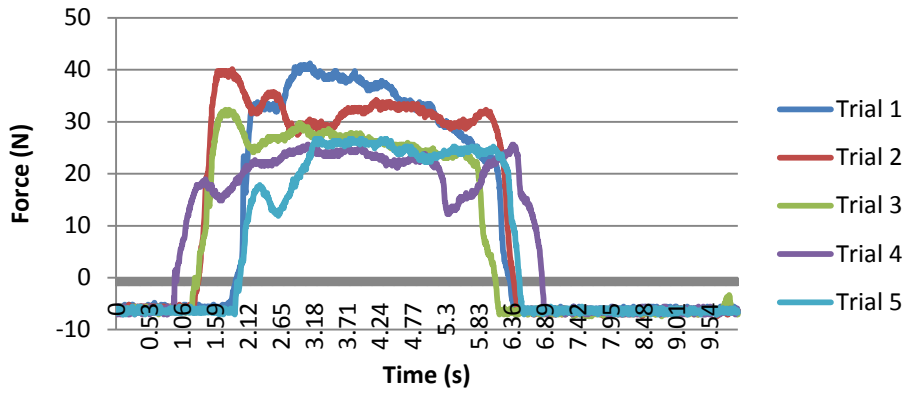

Mx for Large Handle: Counterclockwise Elliptical Incision

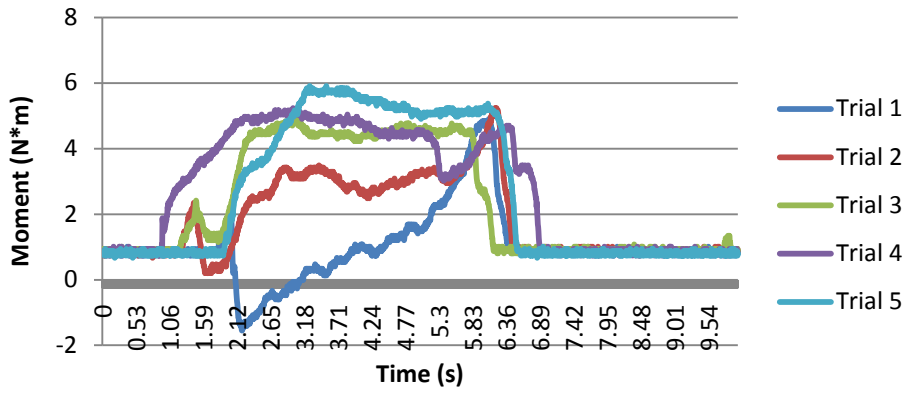

My for Large Handle: Counterclockwise Elliptical Incision

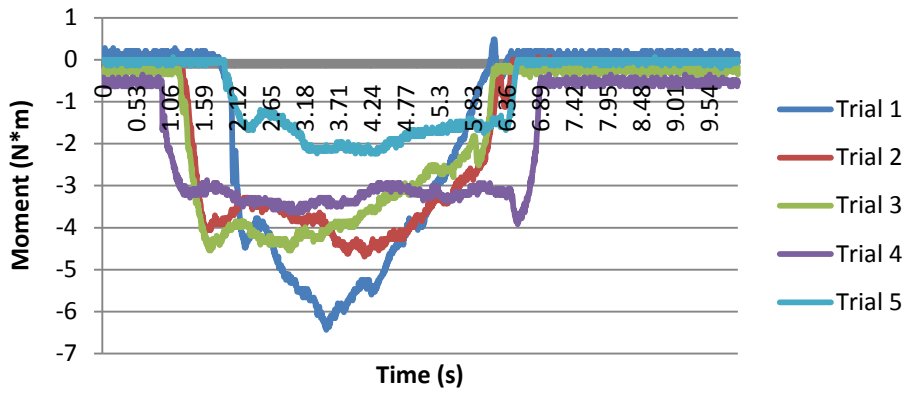

Mz for Large Handle: Counterclockwise Elliptical Incision

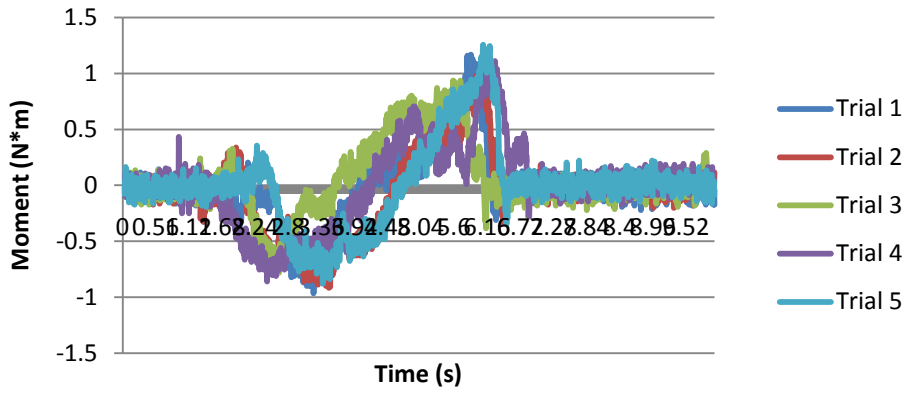

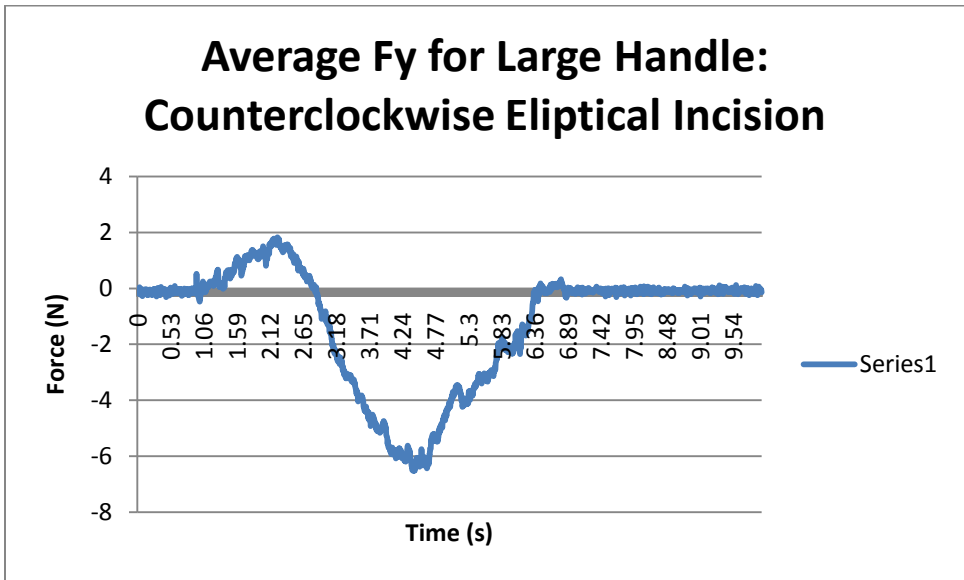
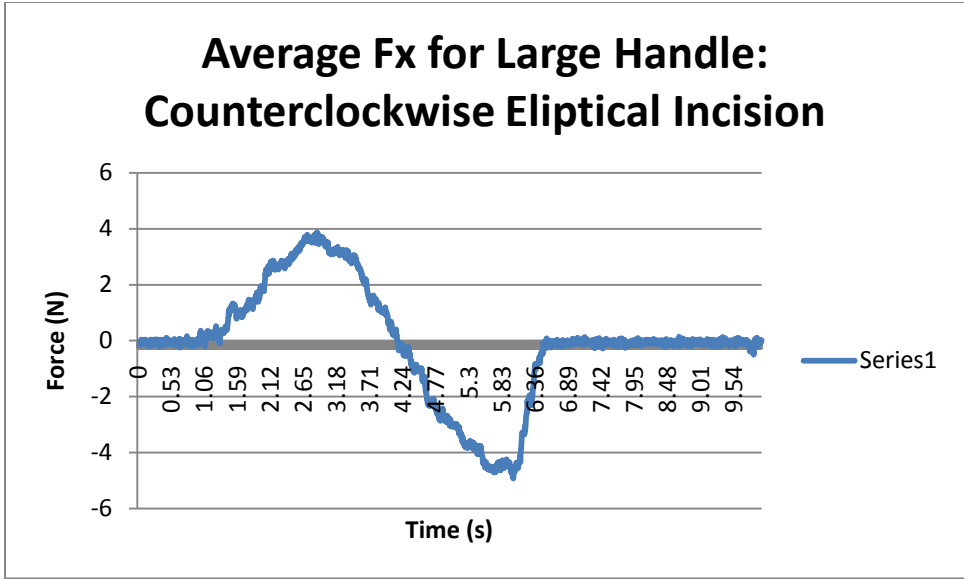

Average Fz for Large Handle: Counterclockwise Elliptical Incision

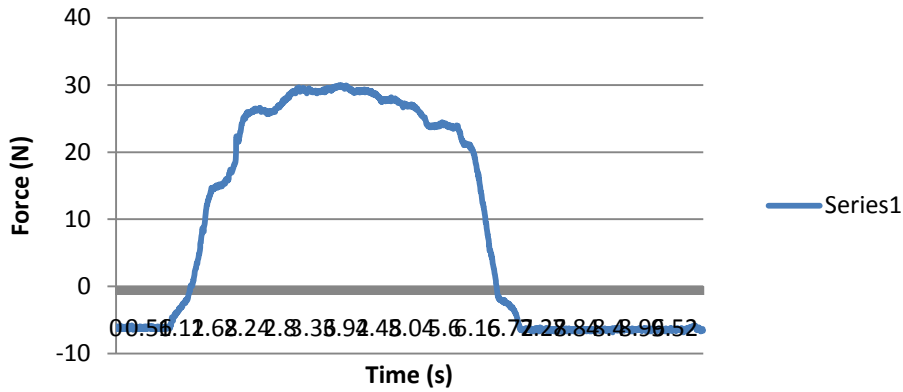

Average Mx for Large Handle: Counterclockwise Elliptical Incision

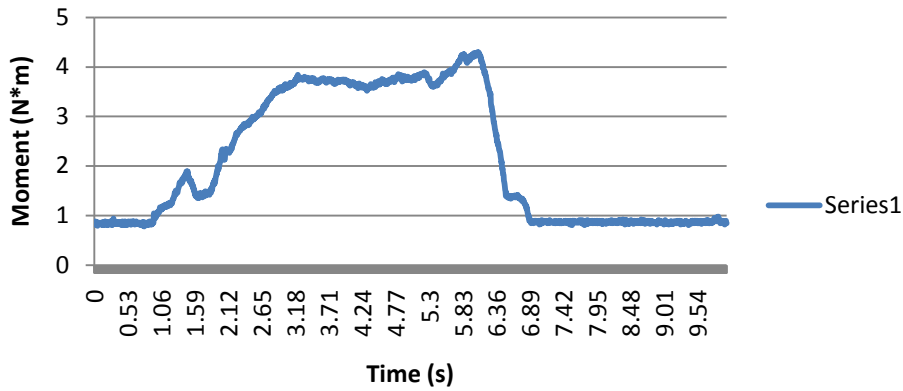

Average My for Large Handle: Counterclockwise Elliptical Incision

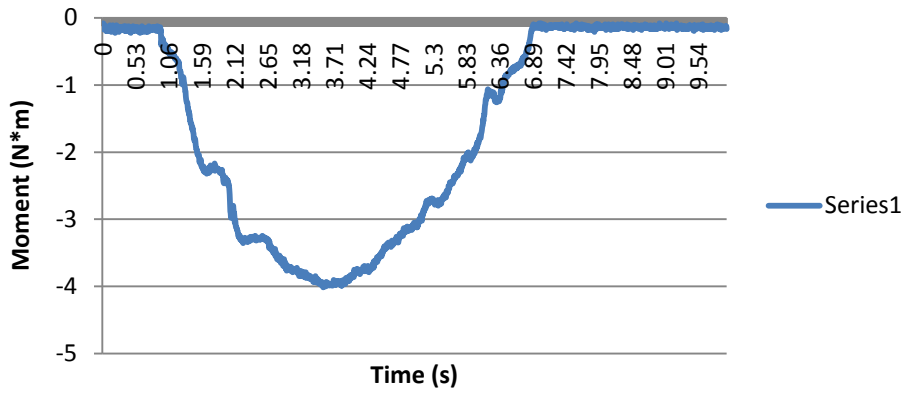

Average Mz for Large Handle: Counterclockwise Elliptical Incision

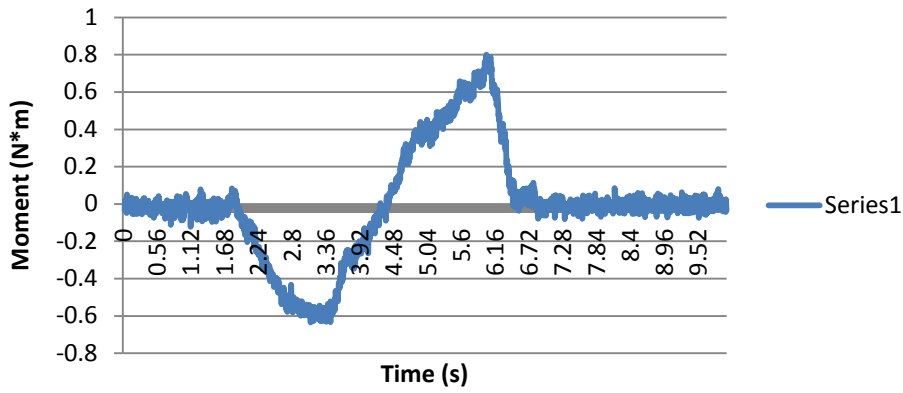

Fx for Large Handle: Clockwise Elliptical Incision

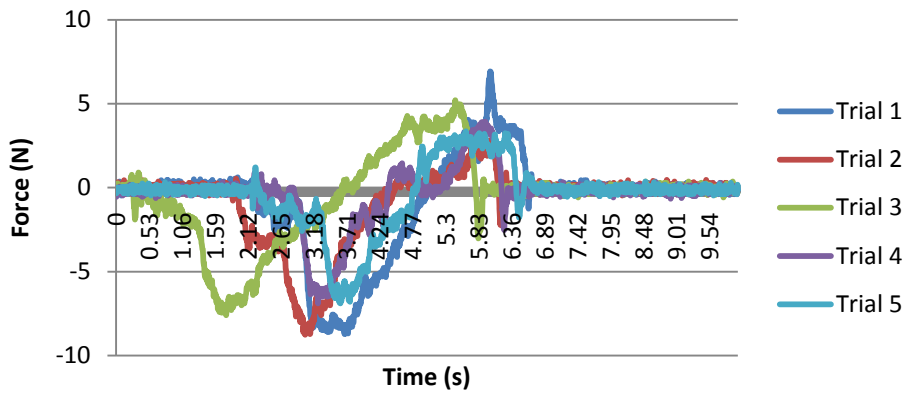

Fy for Large Handle: Clockwise Elliptical Incision

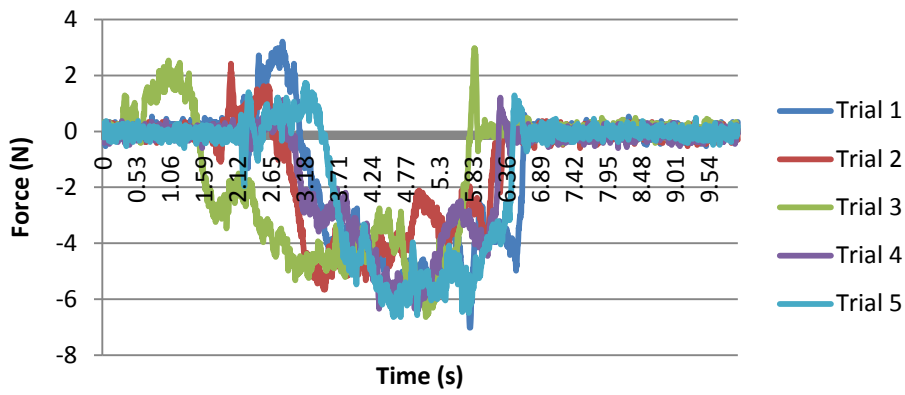

Fz for Large Handle: Clockwise Elliptical Incision

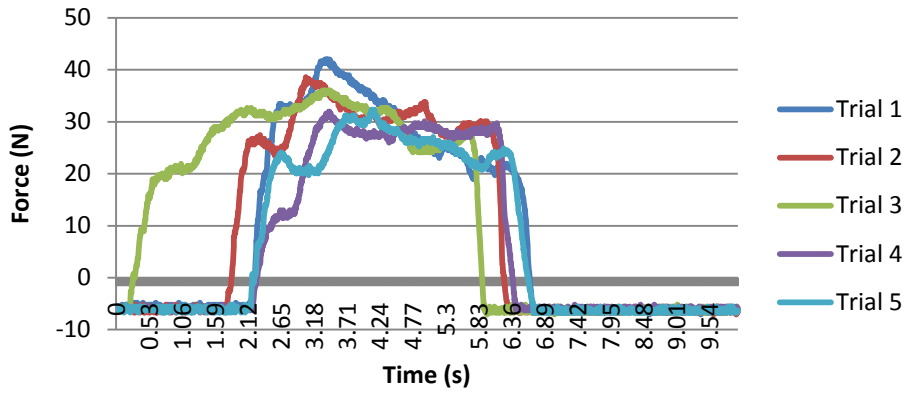

Mx for Large Handle: Clockwise Elliptical Incision

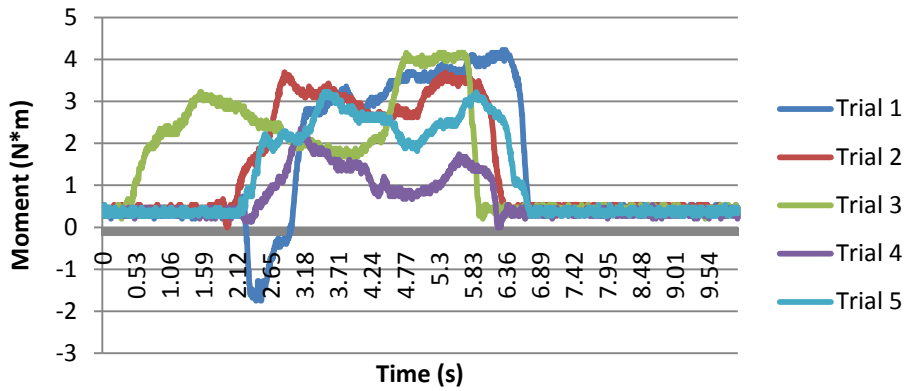

My for Large Handle: Clockwise Elliptical Incision

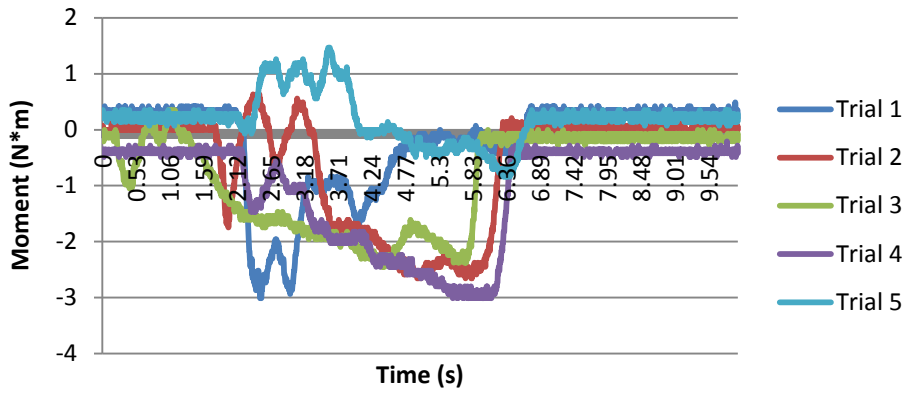

Mz for Large Handle: Clockwise Elliptical Incision

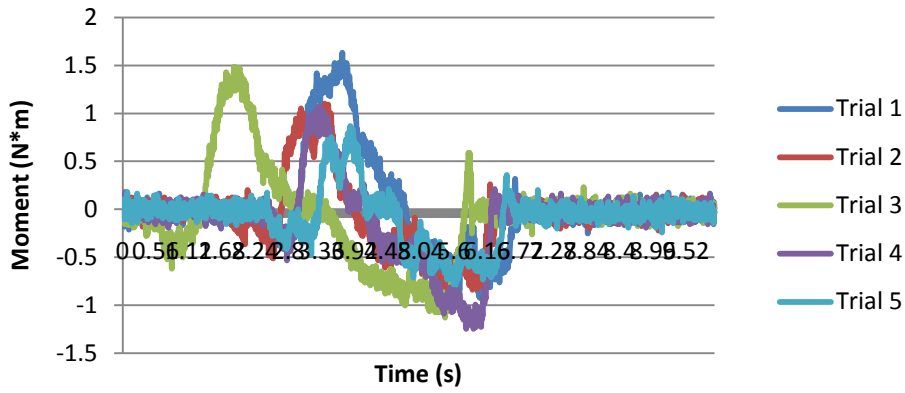

Average Fx for Large Handle: Clockwise Elliptical Incision

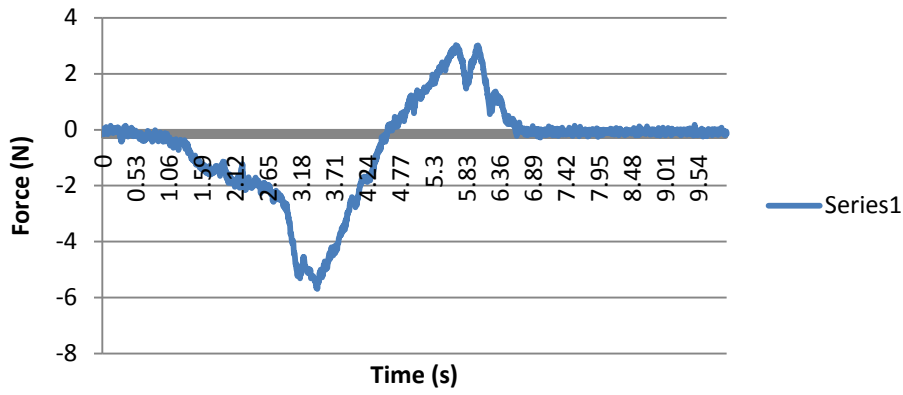

Average Fy for Large Handle: Clockwise Elliptical Incision

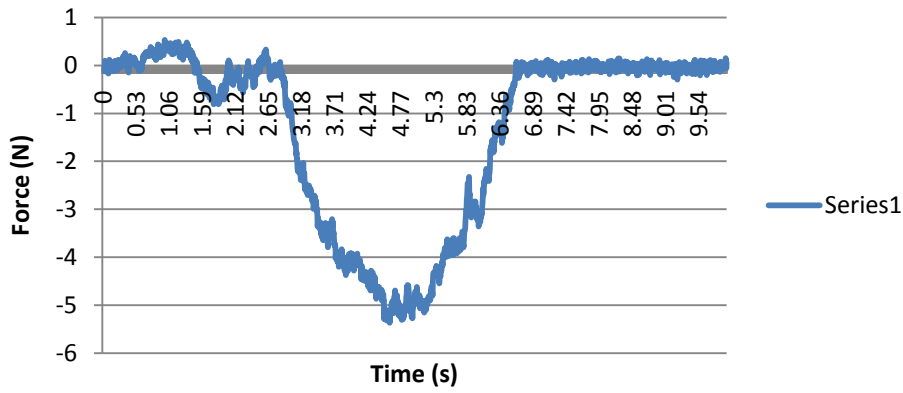

Average Fz for Large Handle: Clockwise Elliptical Incision

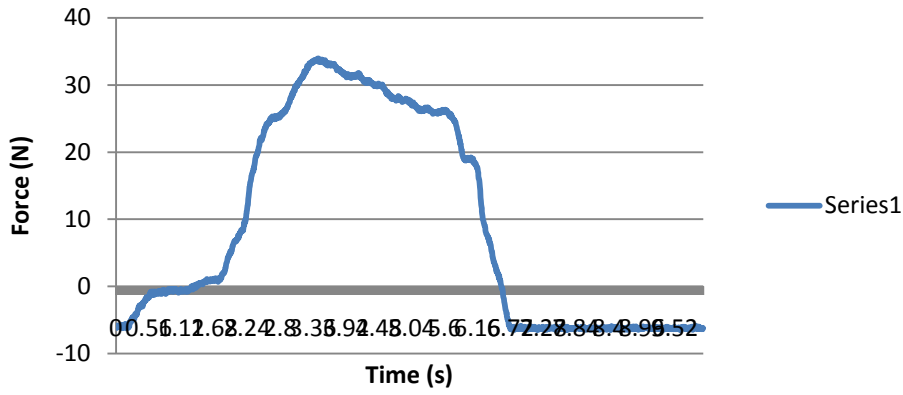

Average Mx for Large Handle: Clockwise Elliptical Incision

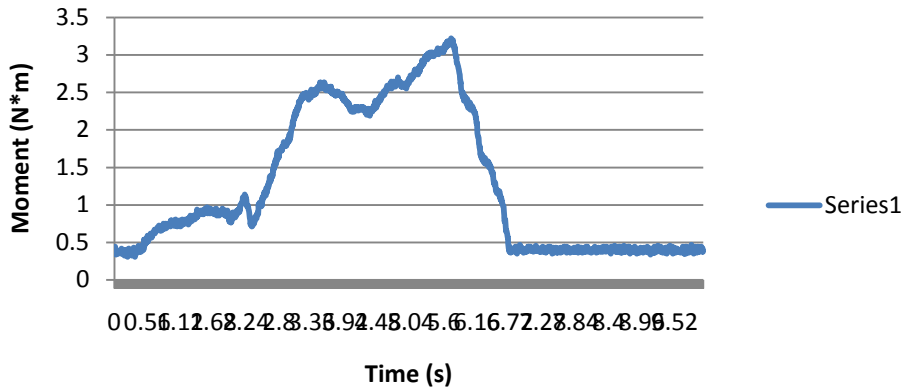

Average My for Large Handle: Clockwise Elliptical Incision

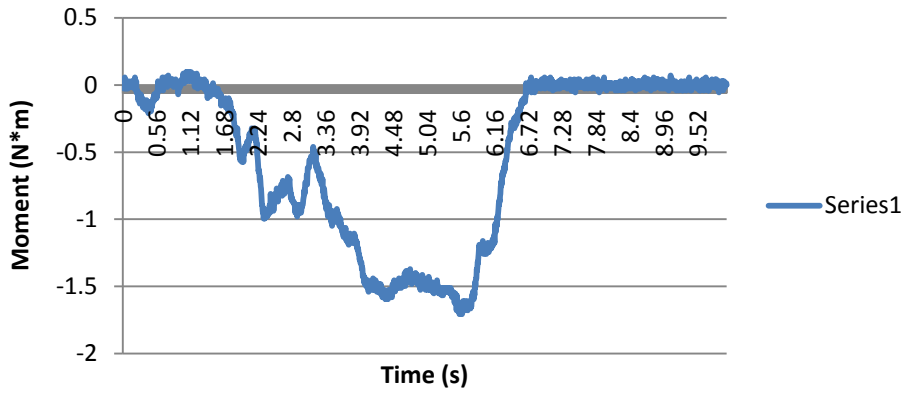

Average Mz for Large Handle: Clockwise Elliptical Incision

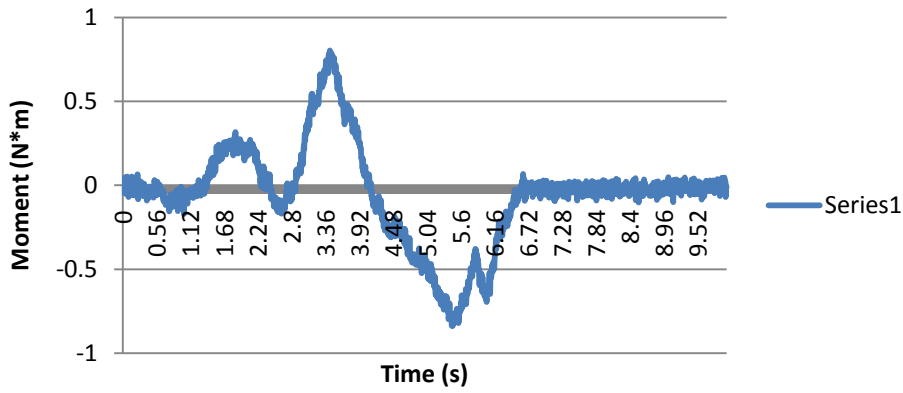

Fx for Large Handle: Horizontal Linear Incision

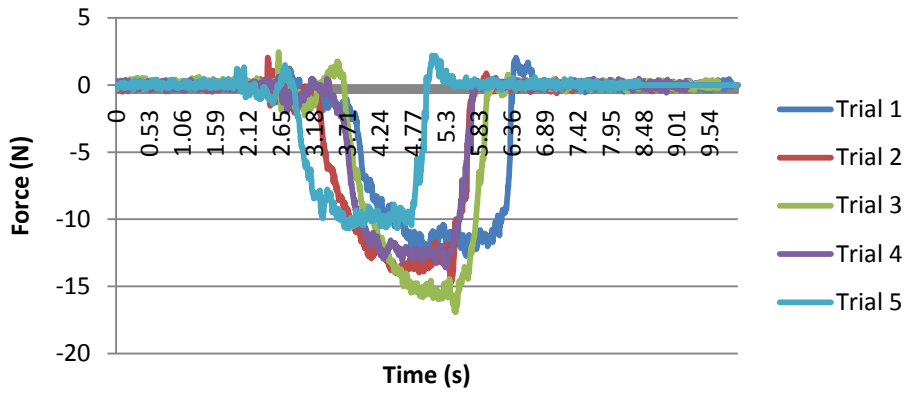

Fy for Large Handle: Horizontal Linear Incision

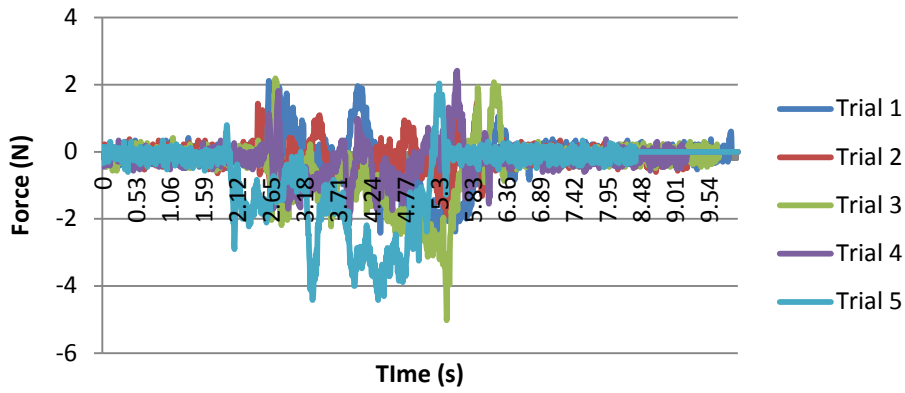

Fz for Large Handle: Horizontal Linear Incision

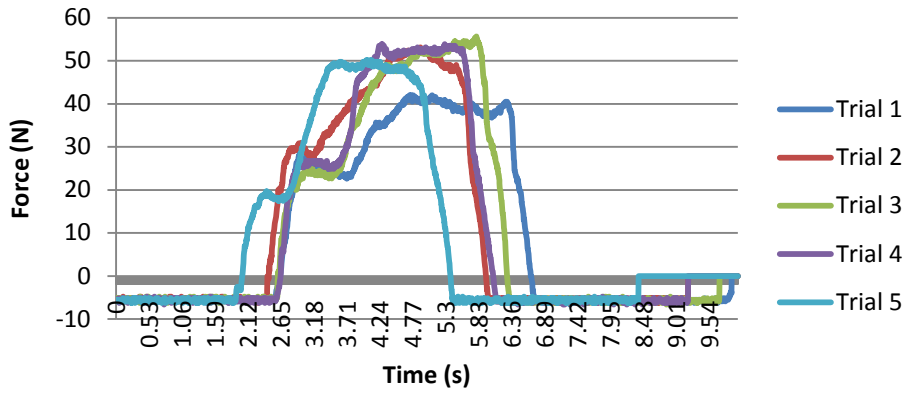

Mx for Large Handle: Horizontal Linear Incision

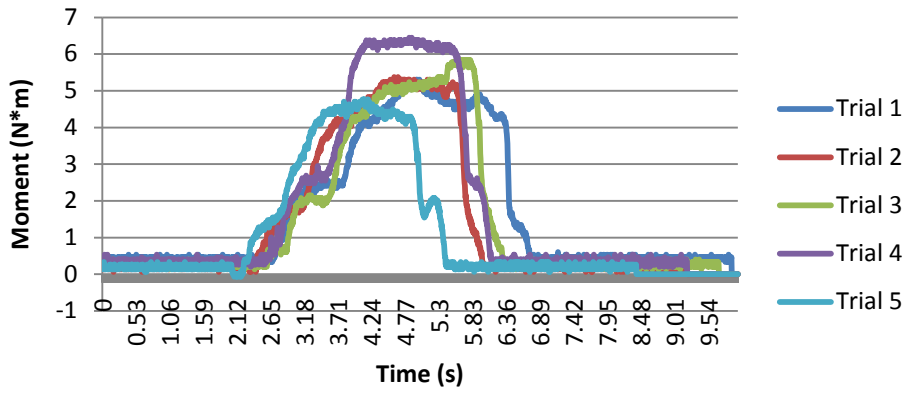

My for Large Handle: Horizontal Linear Incision

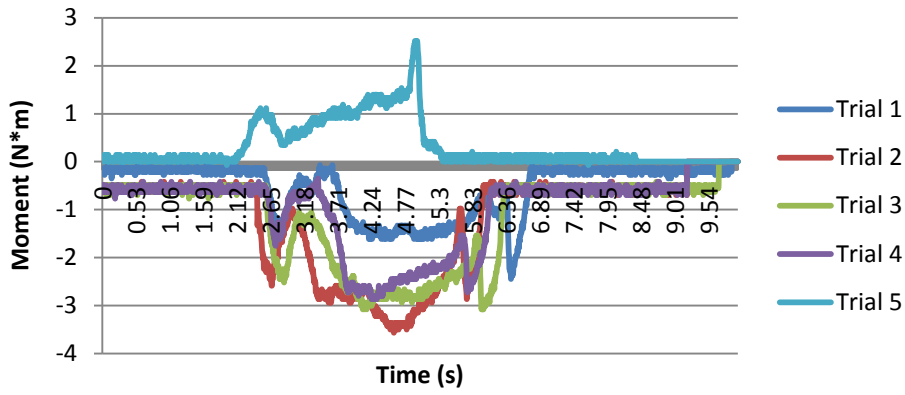

Mz for Large Handle: Horizontal Linear Incision

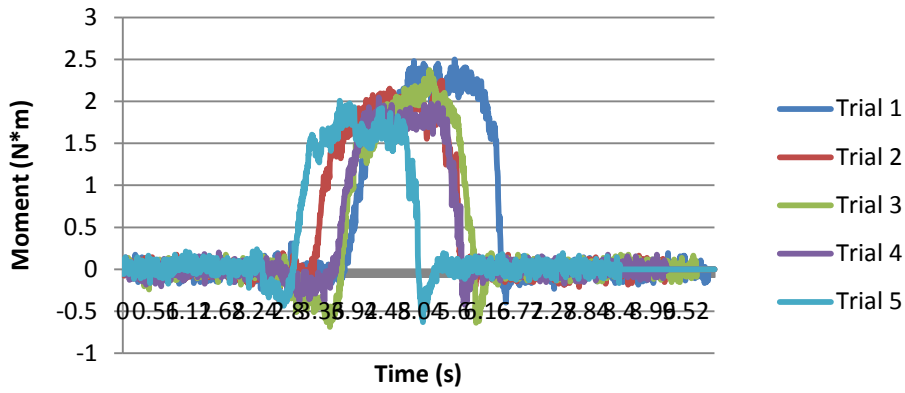

Average Fx for Large Handle: Horizontal Linear Incision

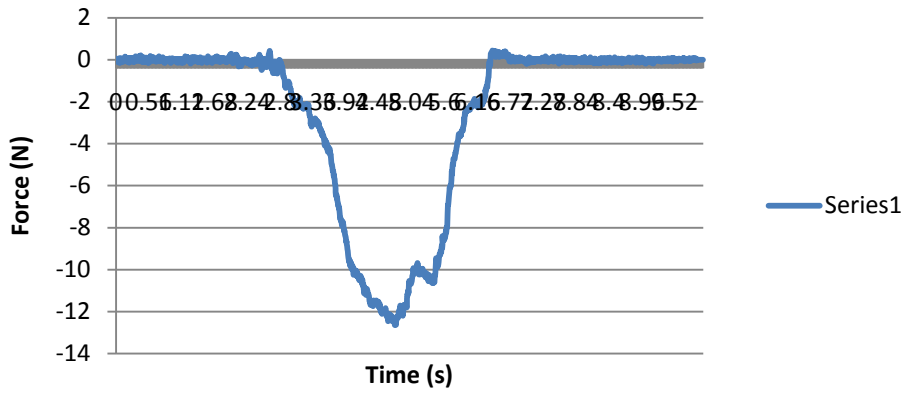

Average Fy for Large Handle: Horizontal Linear Incision

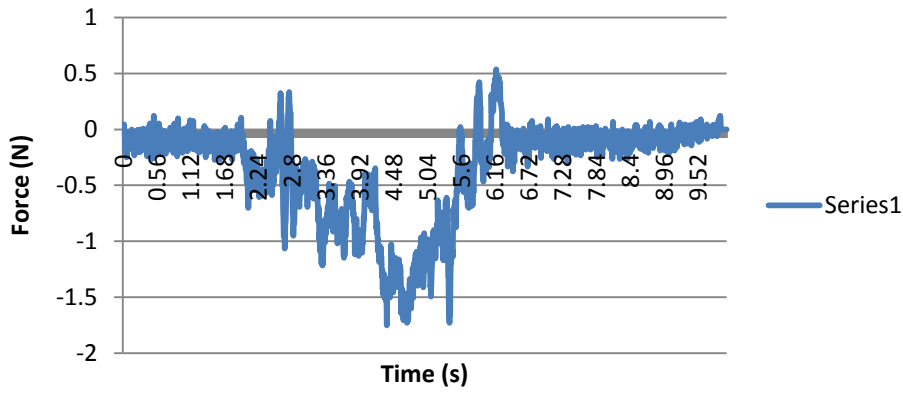

Average Fz for Large Handle: Horizontal Linear Incision

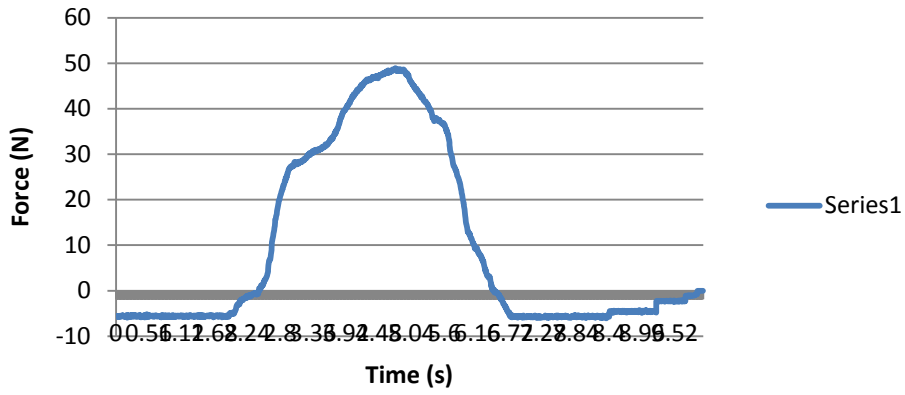

Average Mx for Large Handle: Horizontal Linear Incision

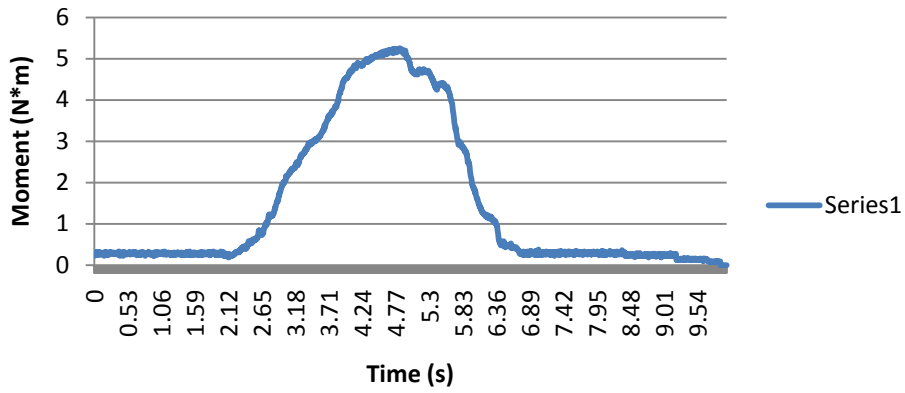

Average My for Large Handle: Horizontal Linear Incision

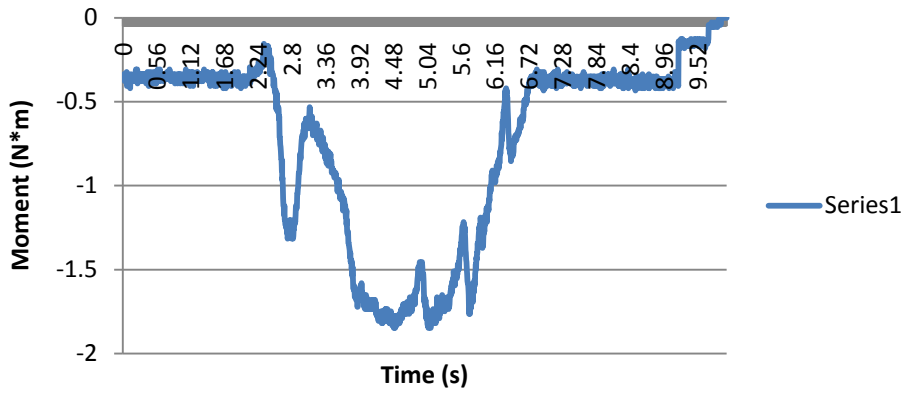

Average Mz for Large Handle: Horizontal Linear Incision

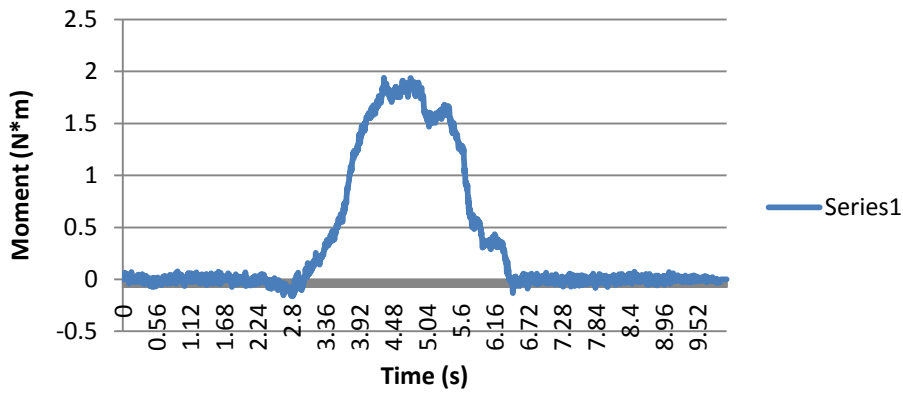

Fx for Large Handle: Vertical Linear Incision

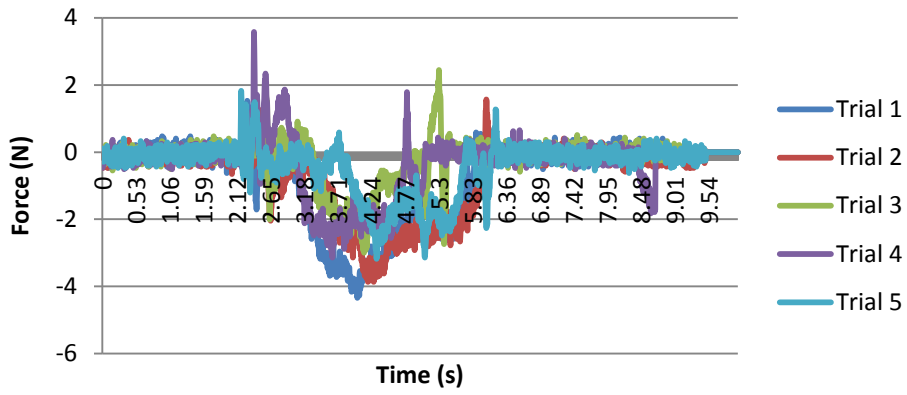

Fy for Large Handle: Vertical Linear Incision

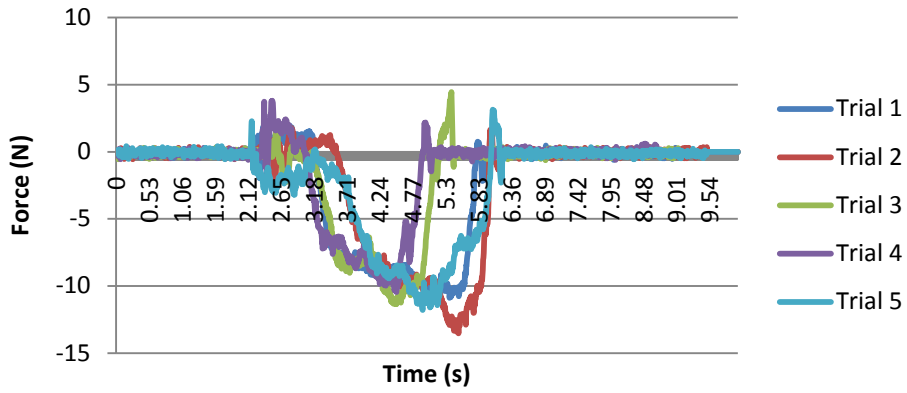

Fz for Large Handle: Vertical Linear Incision

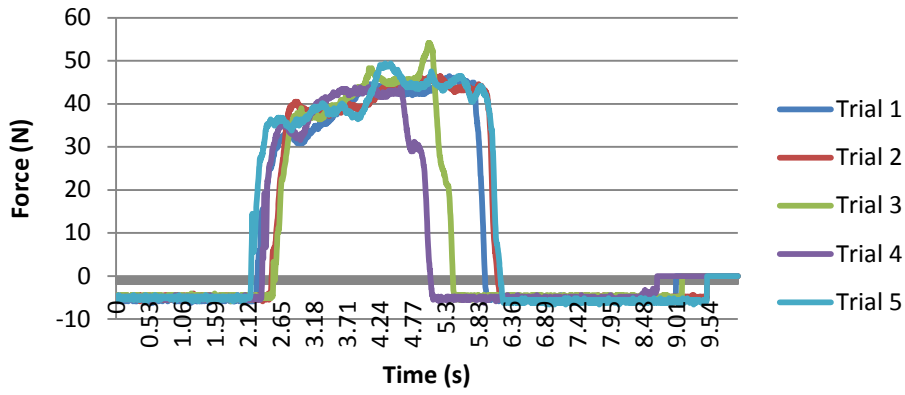

Mx for Large Handle: Vertical Linear Incision

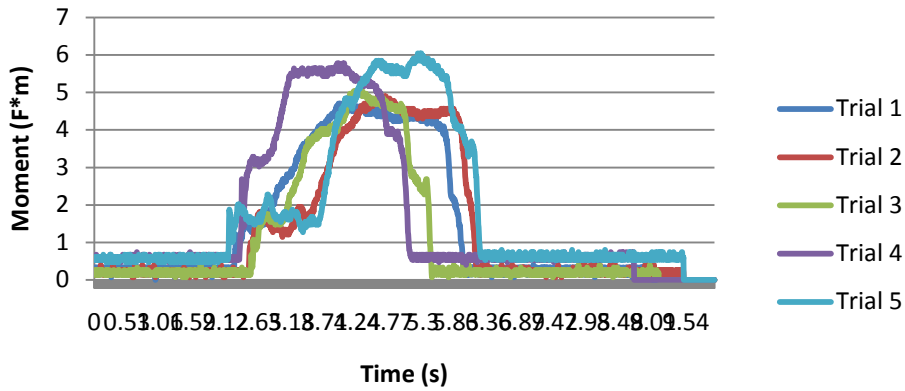

My for Large Handle: Vertical Linear Incision

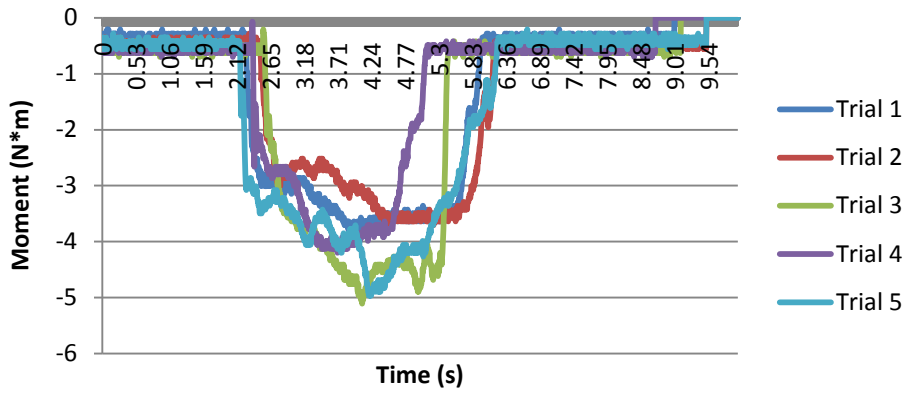

Mz for Large Handle: Vertical Linear Incision

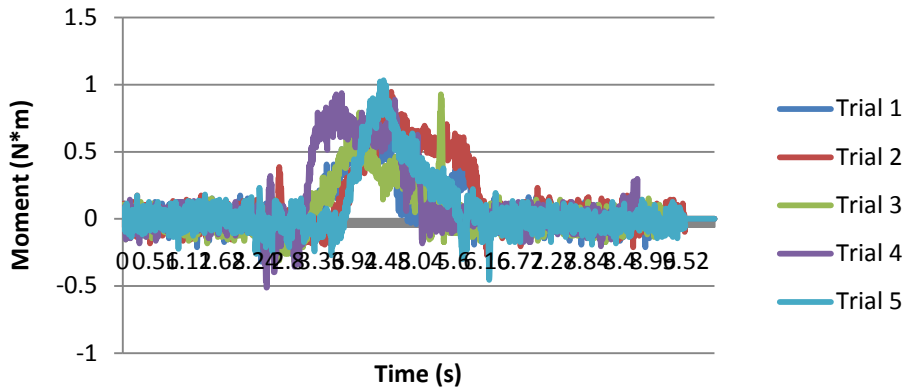

Average Fx for Large Handle: Vertical Linear Incision

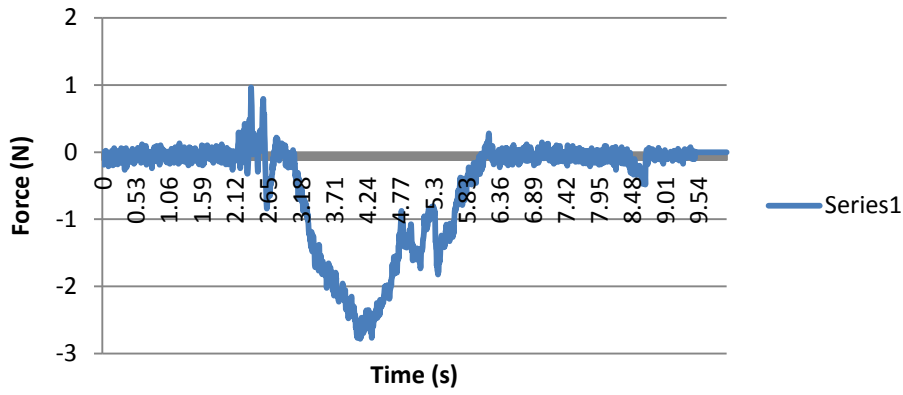

Average Fy for Large Handle: Vertical Linear Incision

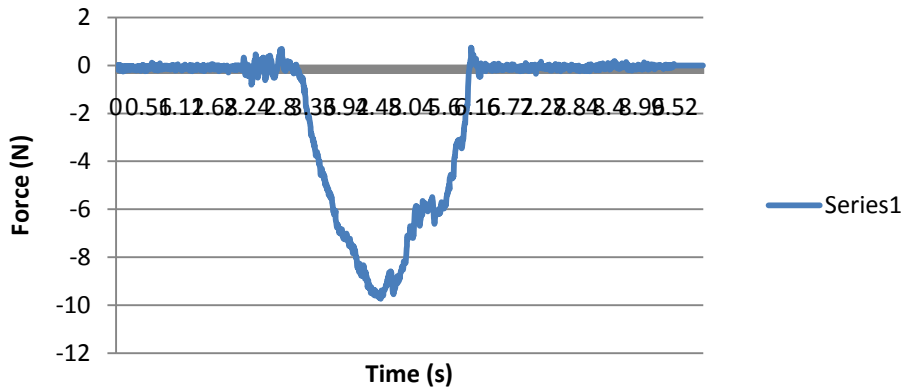

Average Fz for Large Handle: Vertical Linear Incision

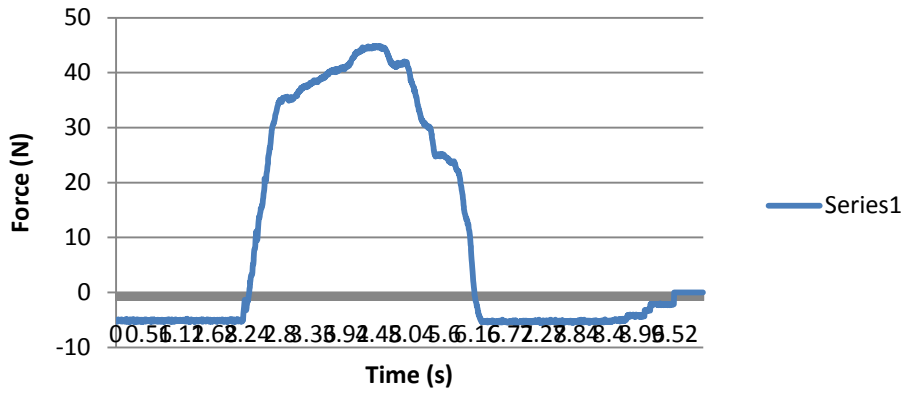

Average Mx for Large Handle: Vertical Linear Incision

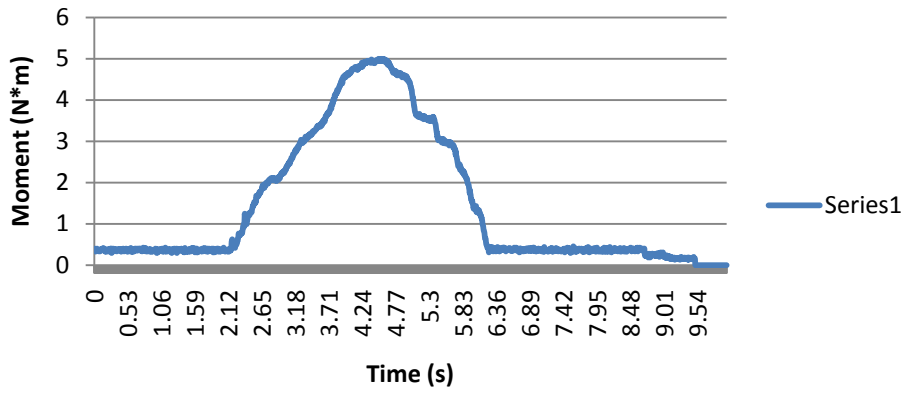

Average My for Large Handle: Vertical Linear Incision

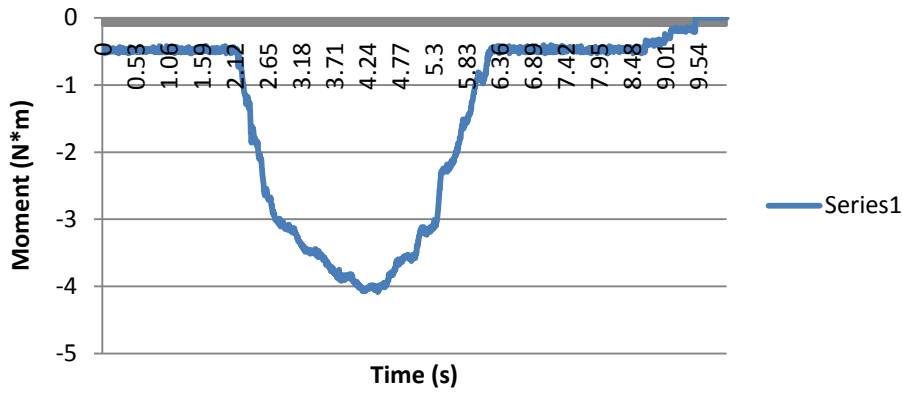

Average Mz for Large Handle: Vertical Linear Incision

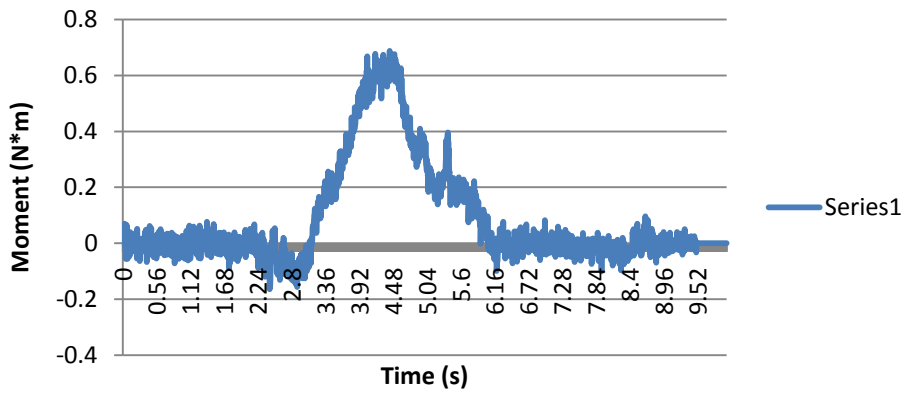

Fx for Green Handle: Counterclockwise Circular Incision

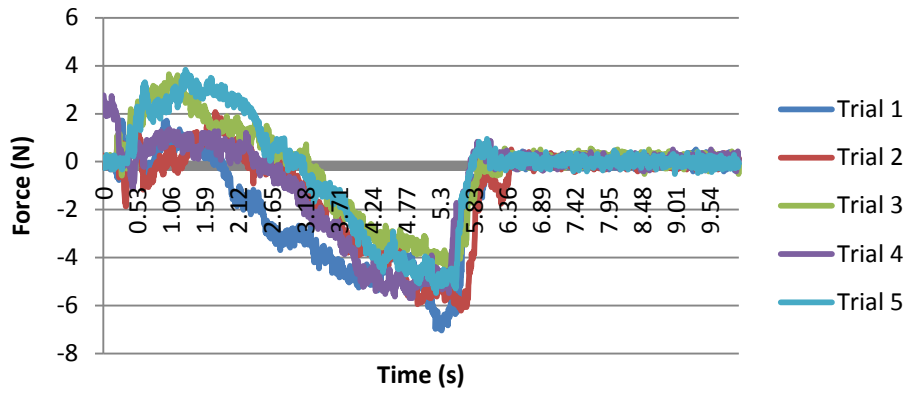

Fy for Green Handle: Counterclockwise Circular Incision

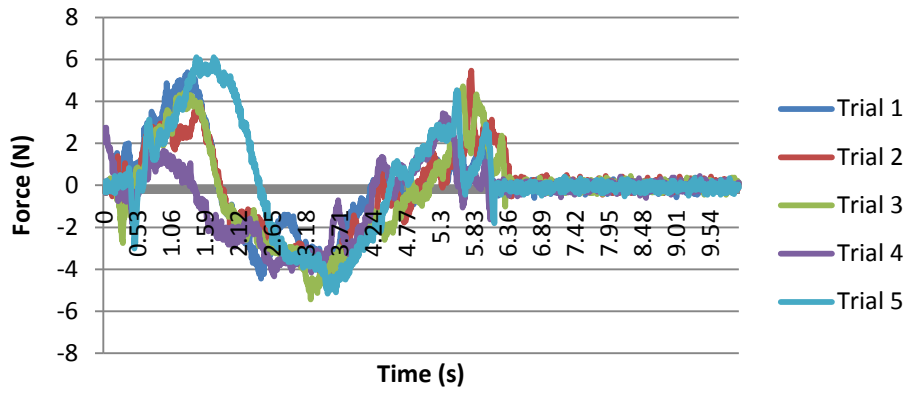

Fz for Green Handle: Counterclockwise Circular Incision

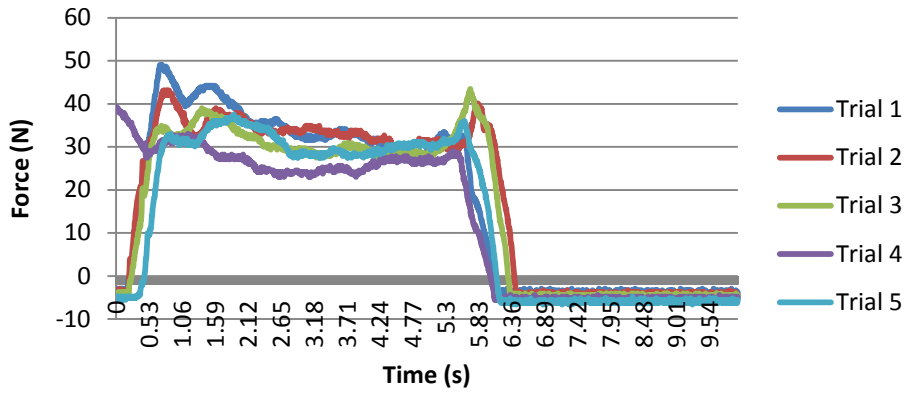

Mx for Green Handle: Counterclockwise Circular Incision

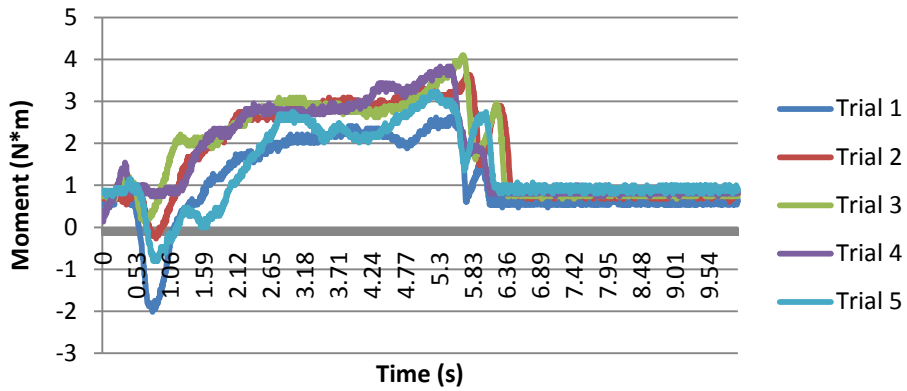

My for Green Handle: Counterclockwise Circular Incision

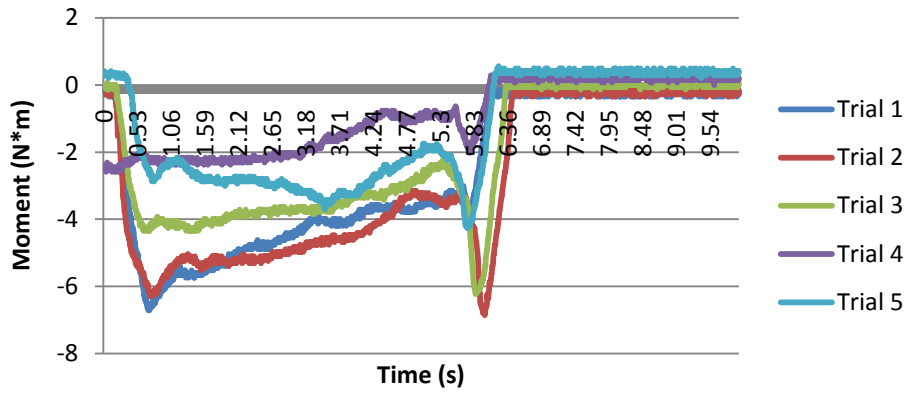

Mz for Green Handle: Counterclockwise Circular Incision

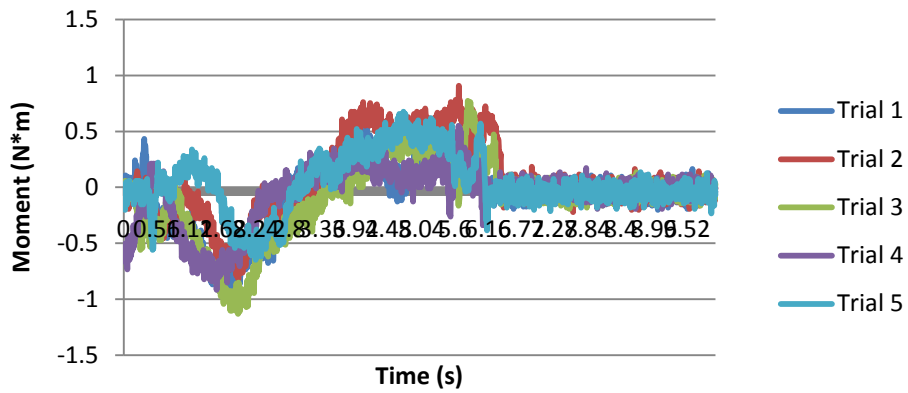

Average Fx for Green Handle: Counterclockwise Circular Incision

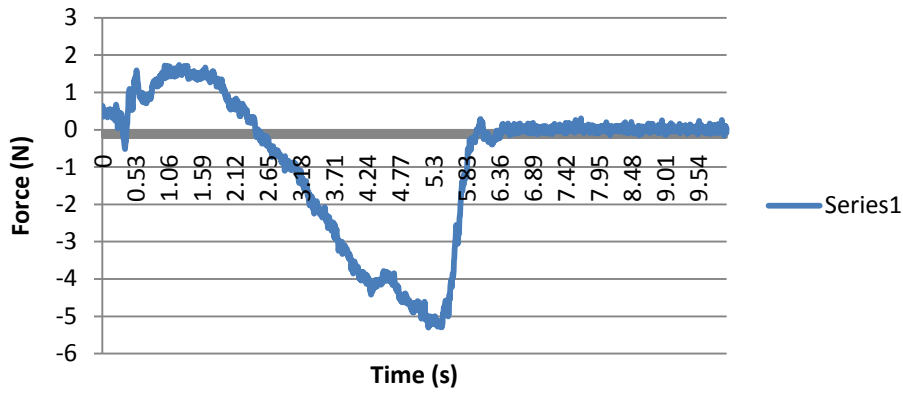

Average Fy for Green Handle: Counterclockwise Circular Incision

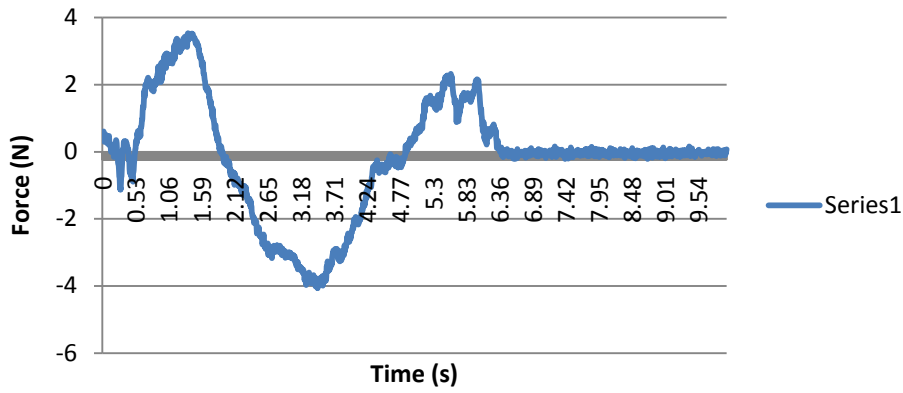

Average Fz for Green Handle: Counterclockwise Circular Incision

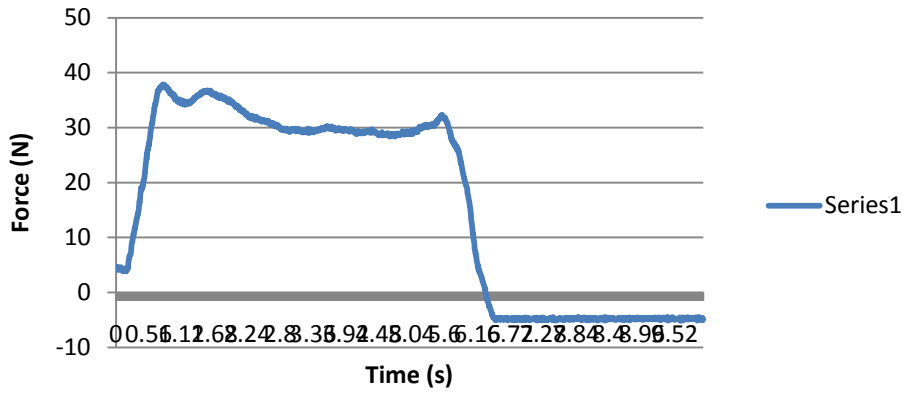

Average Mx for Green Handle: Counterclockwise Circular Incision

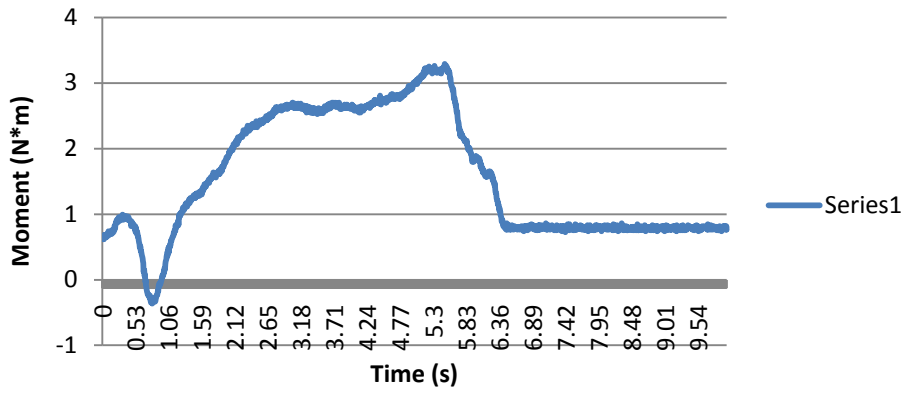

Average M_y for Green Handle: Counterclockwise Circular Incision

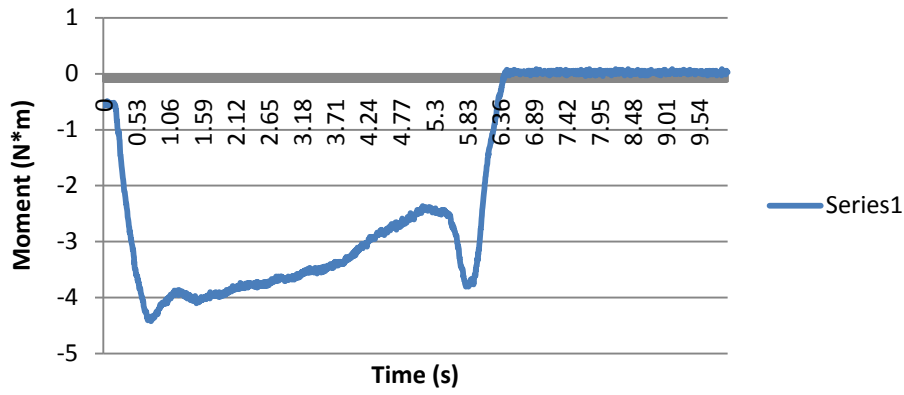

Average M_z for Green Handle: Counterclockwise Circular Incision

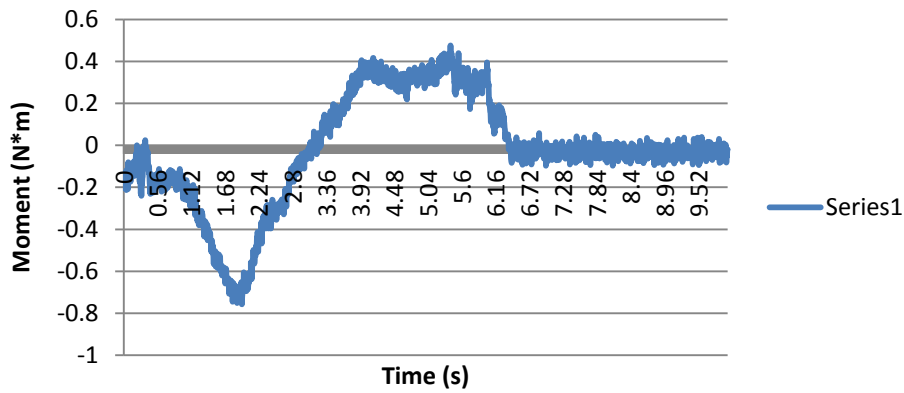

Fx for Green Handle: Clockwise Circular Incision

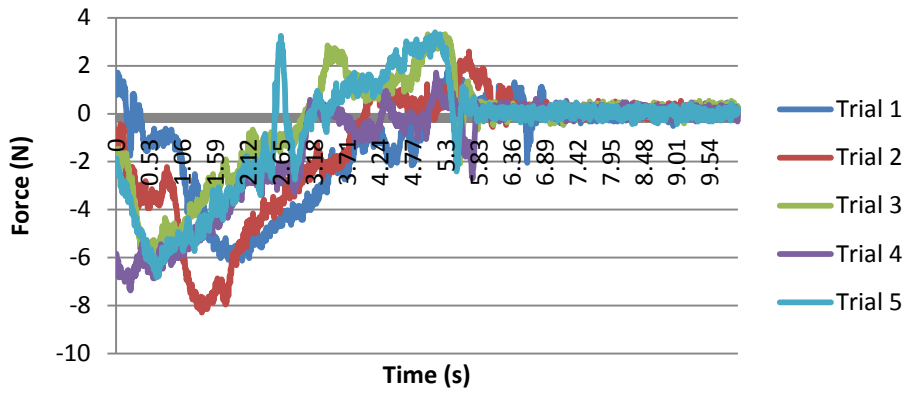

Fy for Green Handle: Clockwise Circular Incision

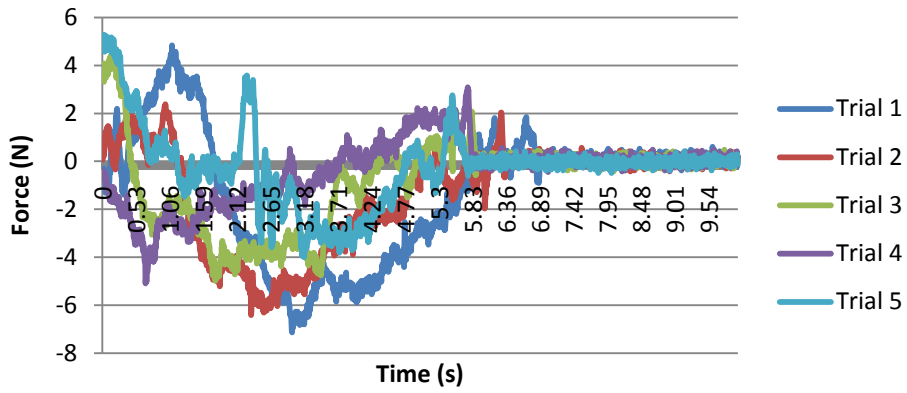

Fz for Green Handle: Clockwise Circular Incision

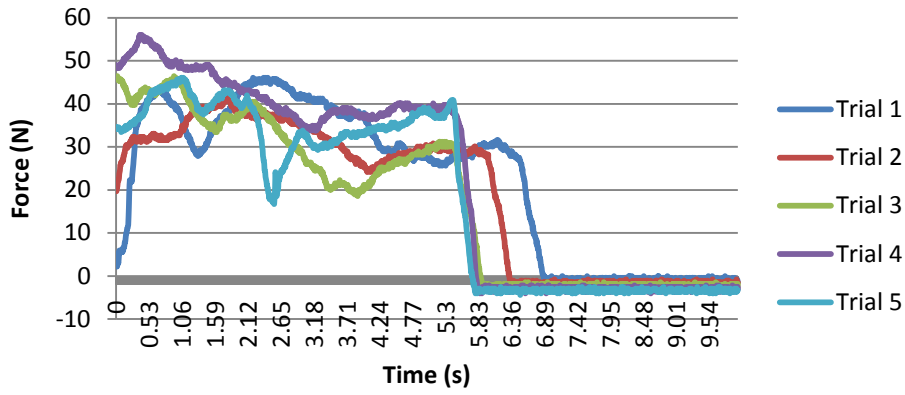

Mx for Green Handle: Clockwise Circular Incision

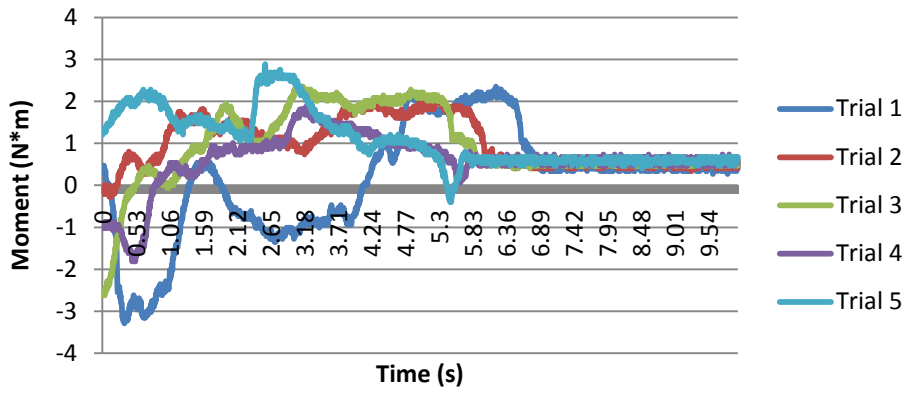

My for Green Handle: Clockwise Circular Incision

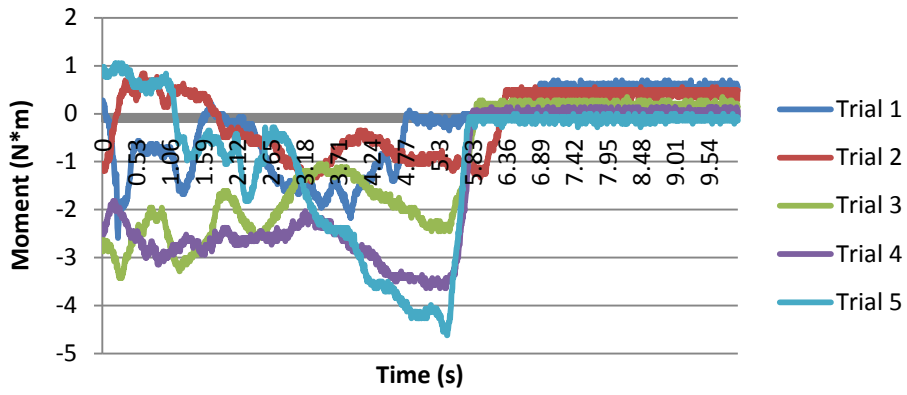

Mz for Green Handle: Clockwise Circular Incision

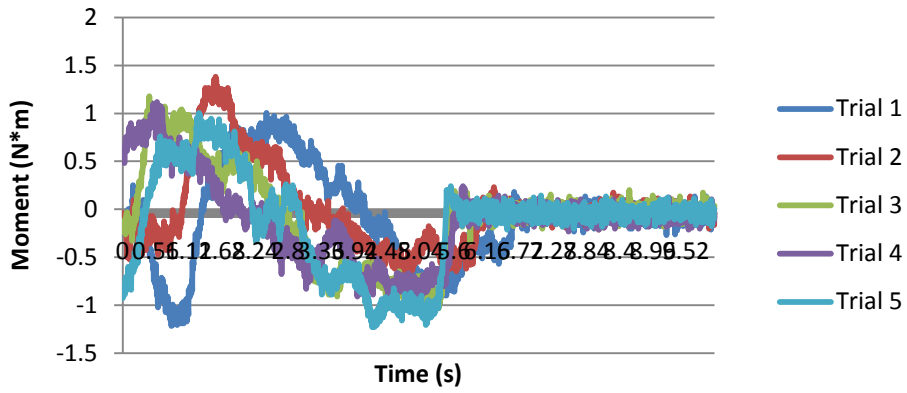

Average Fx for Green Handle: Clockwise Circular Incision

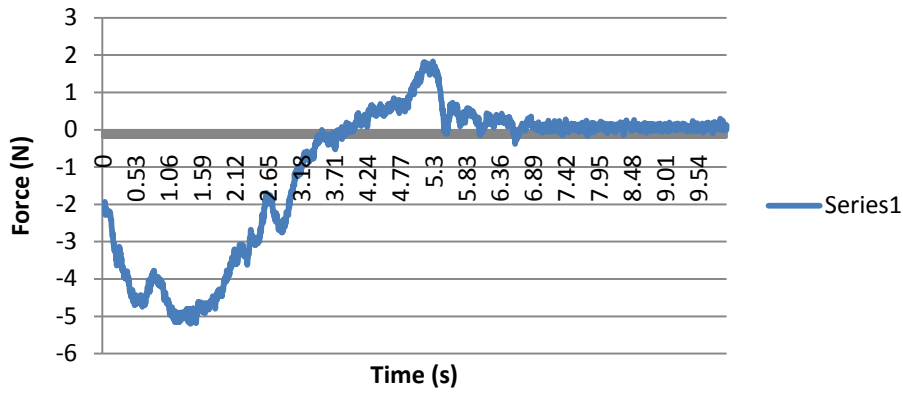

Average Fy for Green Handle: Clockwise Circular Incision

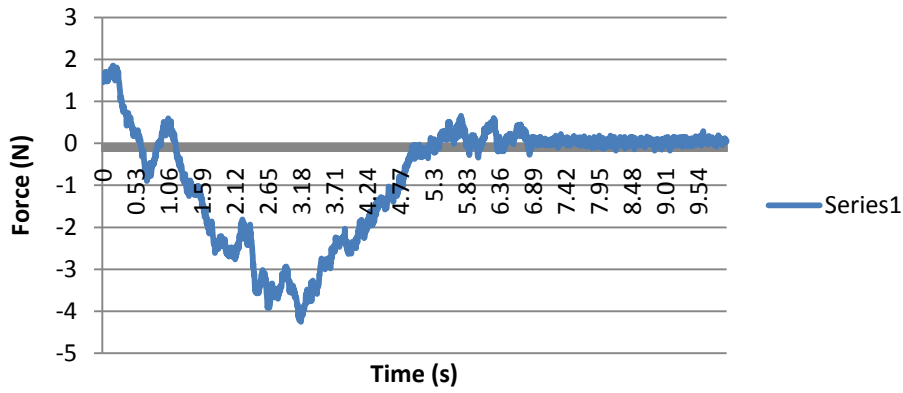

Average Fz for Green Handle: Clockwise Circular Incision

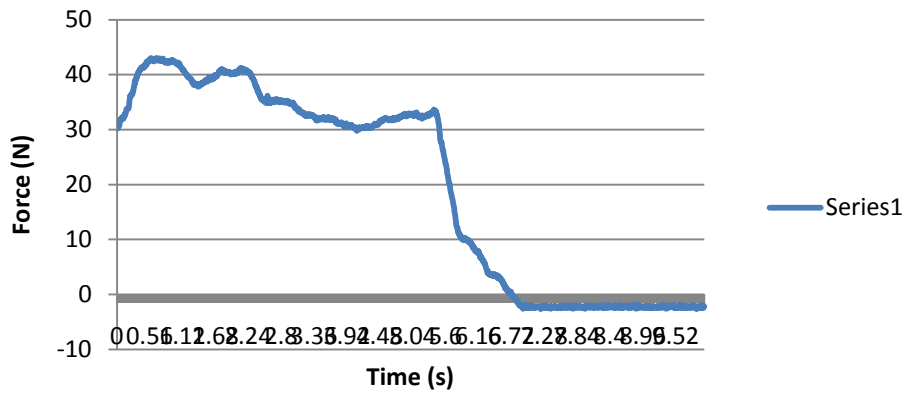

Average Mx for Green Handle: Clockwise Circular Incision

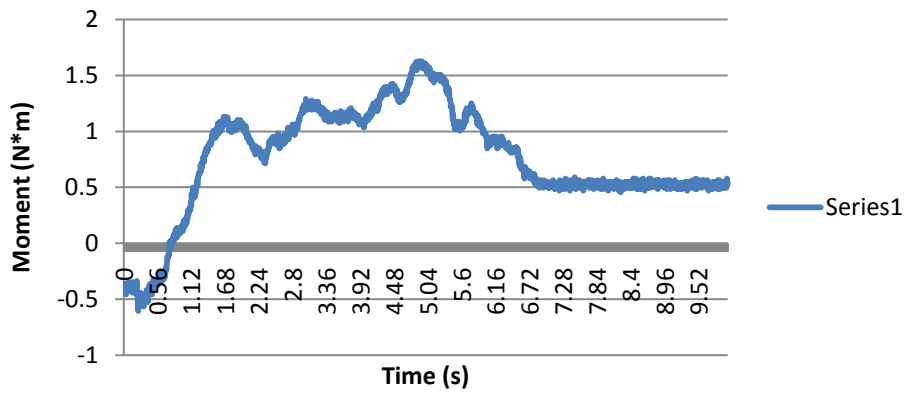

Average My for Green Handle: Clockwise Circular Incision

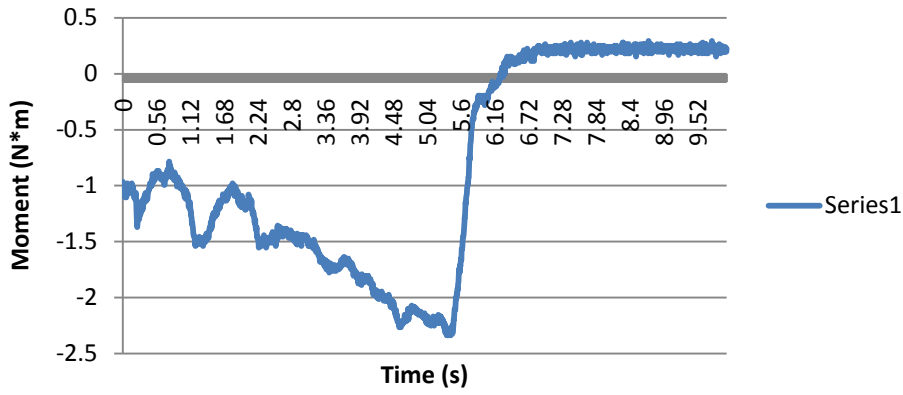

Average Mz for Green Handle: Clockwise Circular Incision

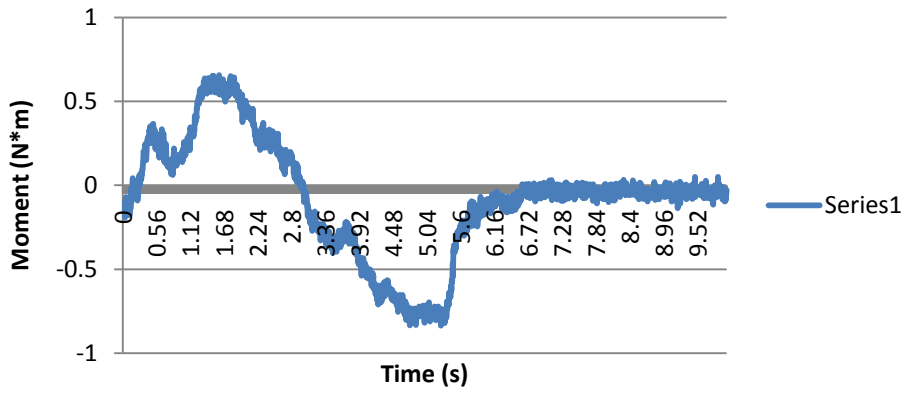

Fx for Green Handle: Counterclockwise Elliptical Incision

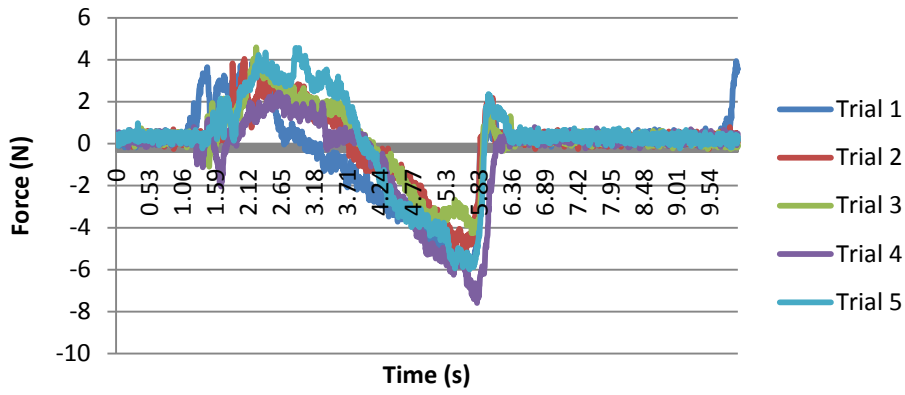

Fy for Green Handle: Counterclockwise Elliptical Incision

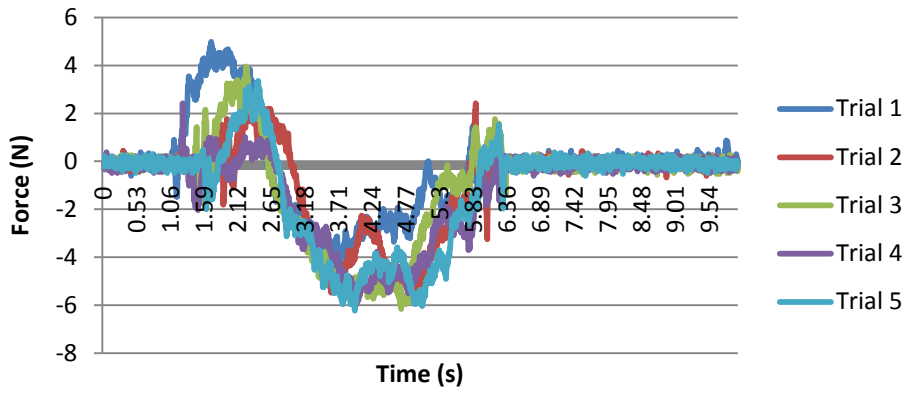

Fz for Green Handle: Counterclockwise Elliptical Incision

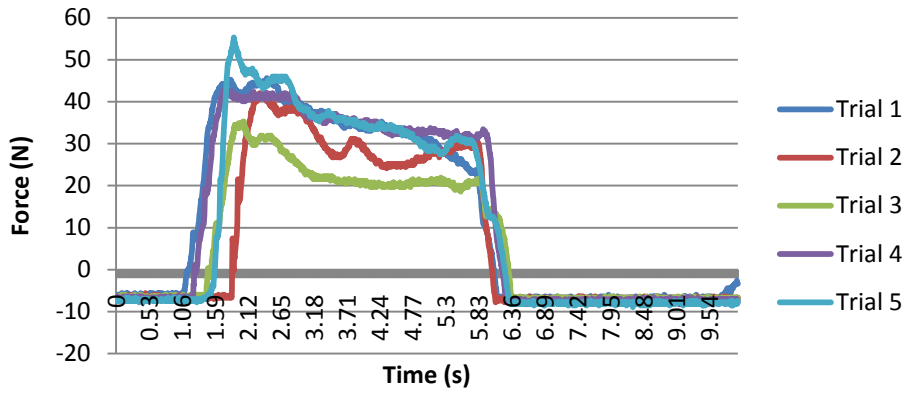

Mx for Green Handle: Counterclockwise Elliptical Incision

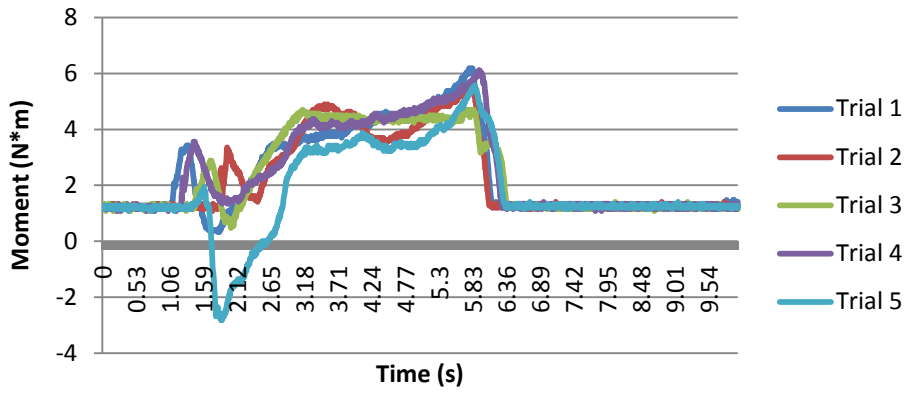

My for Green Handle: Counterclockwise Elliptical Incision

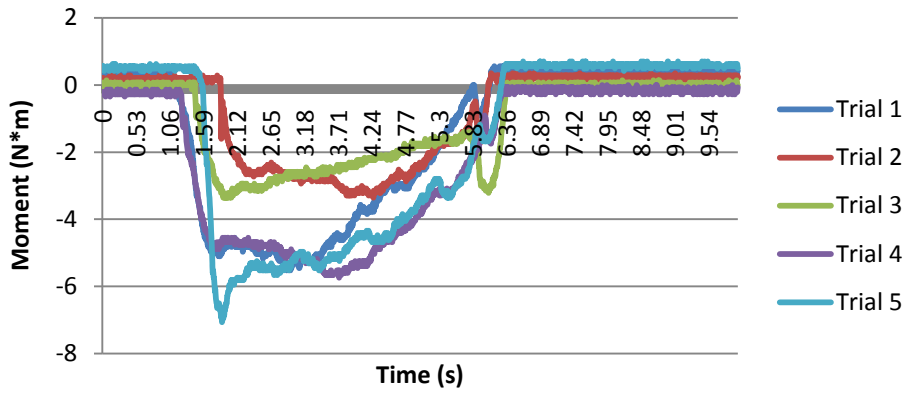

Mz for Green Handle: Counterclockwise Elliptical Incision

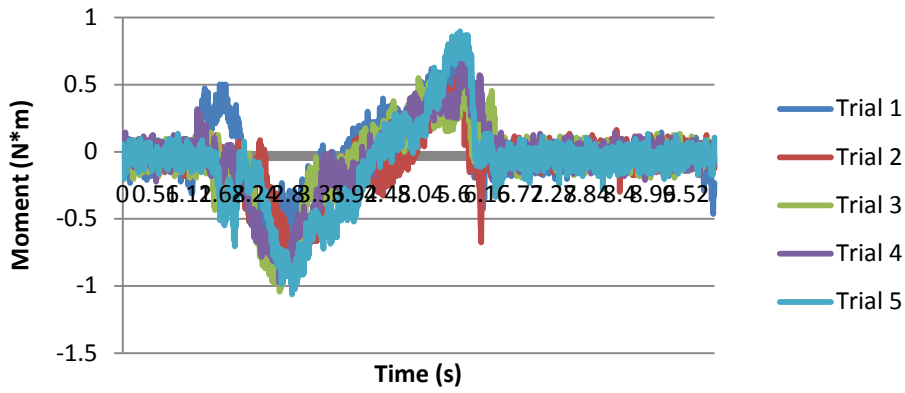

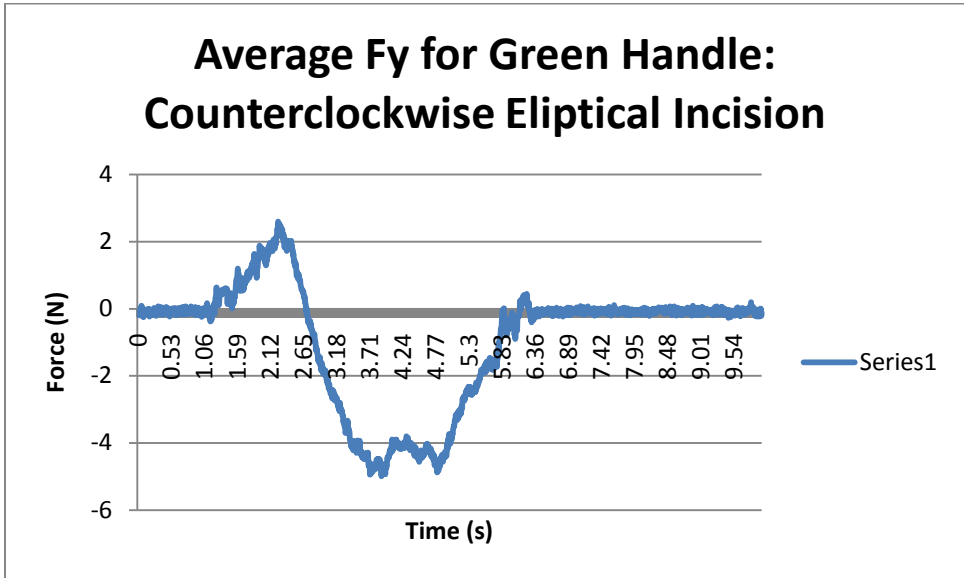
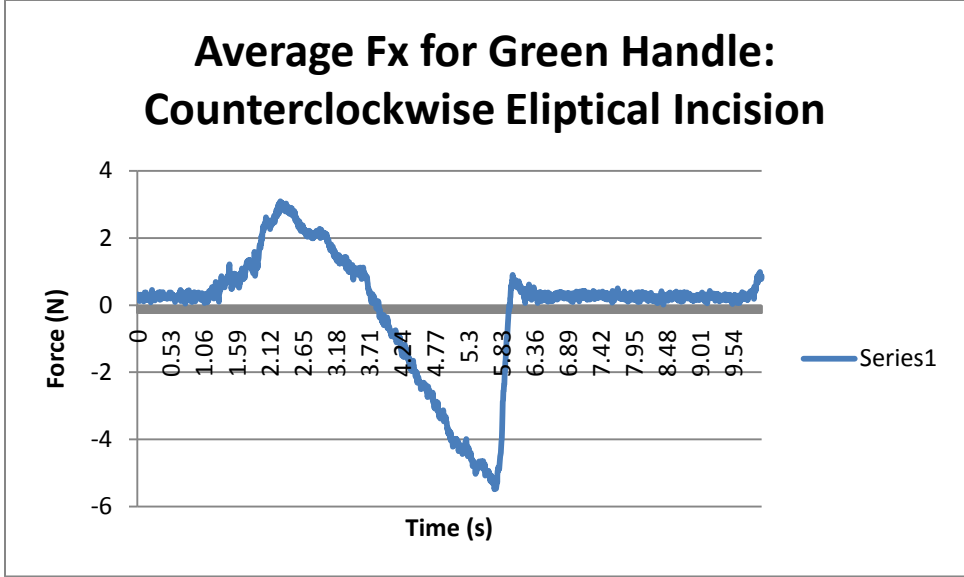

Average Fz for Green Handle: Counterclockwise Elliptical Incision

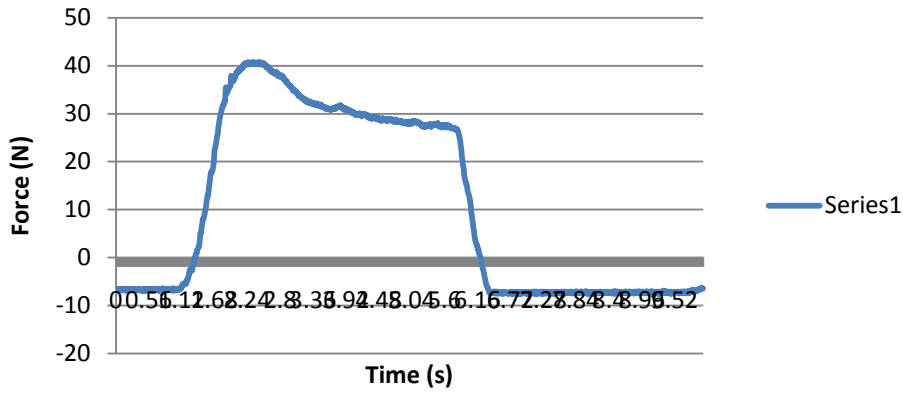

Average Mx for Green Handle: Counterclockwise Elliptical Incision

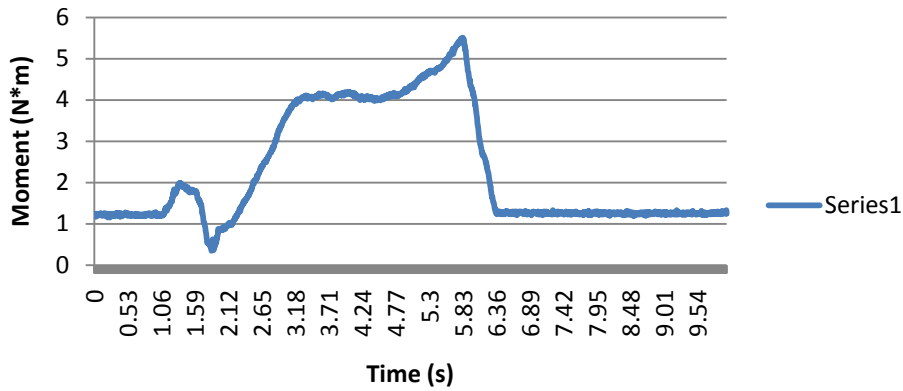

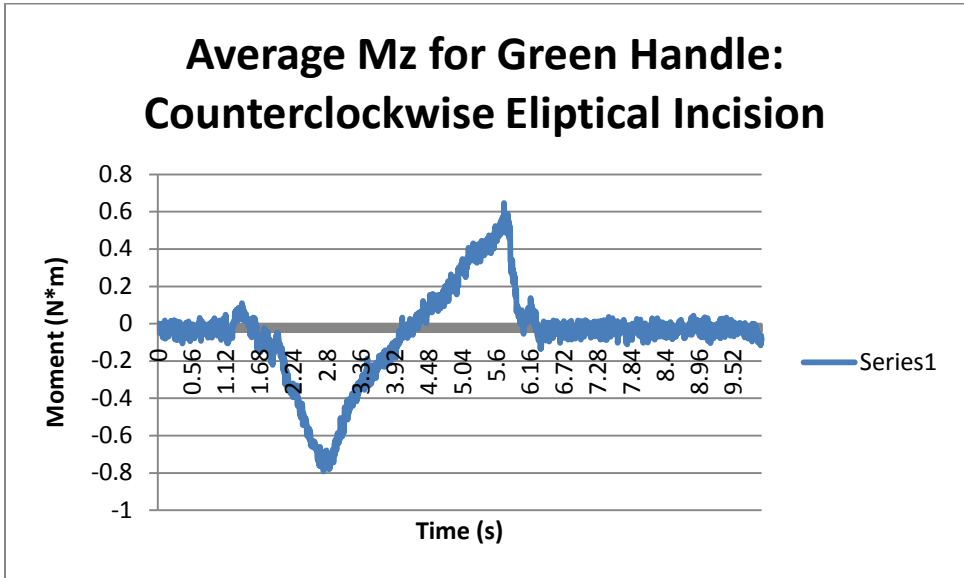
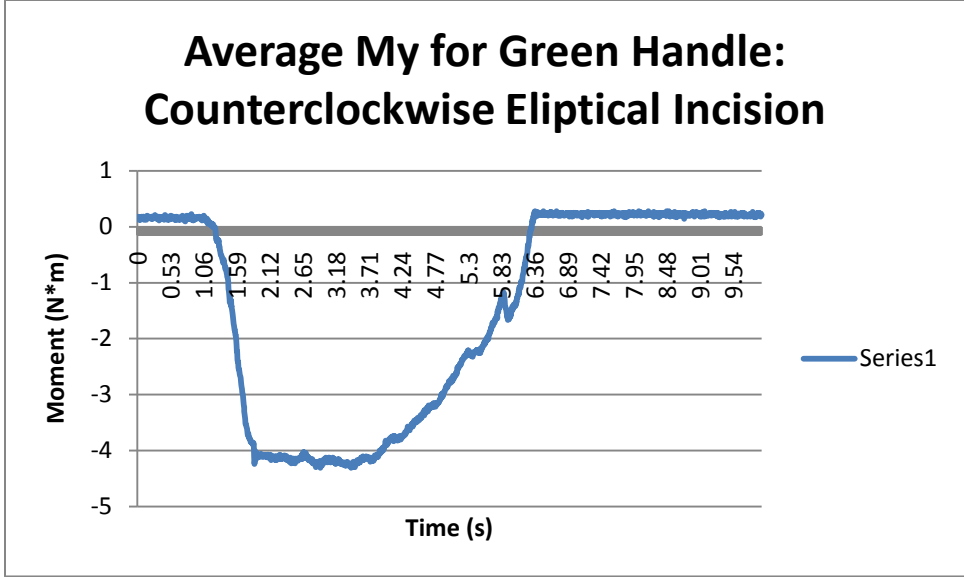

Fx for Green Handle: Clockwise Elliptical Incision

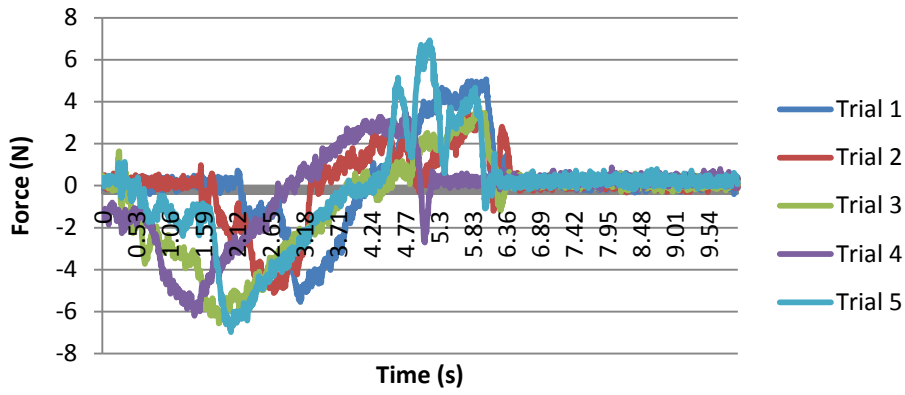

Fy for Green Handle: Clockwise Elliptical Incision

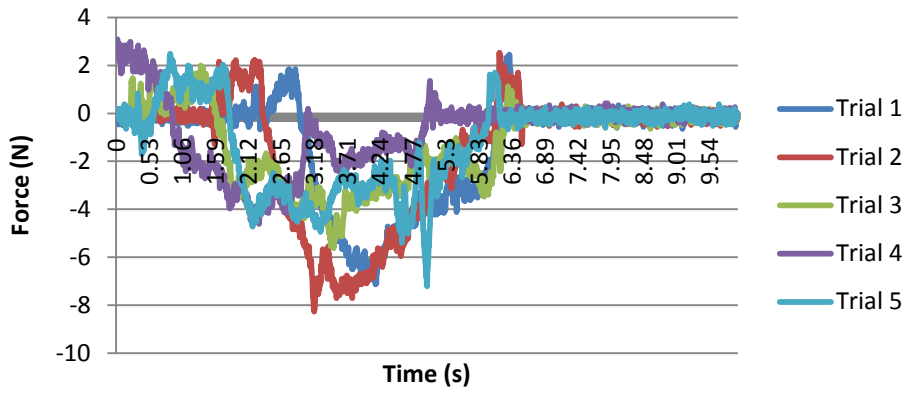

Fz for Green Handle: Clockwise Elliptical Incision

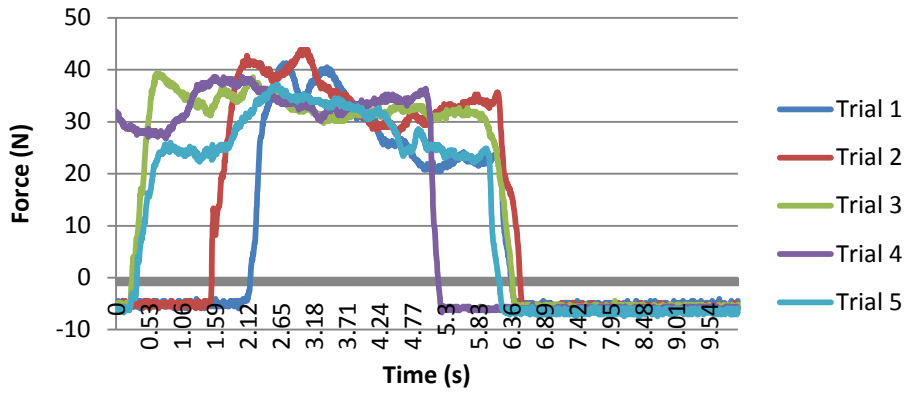

Mx for Green Handle: Clockwise Elliptical Incision

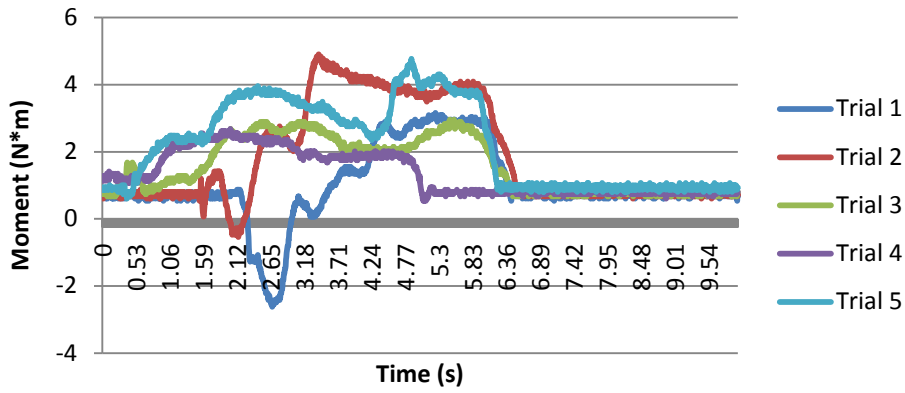

My for Green Handle: Clockwise Elliptical Incision

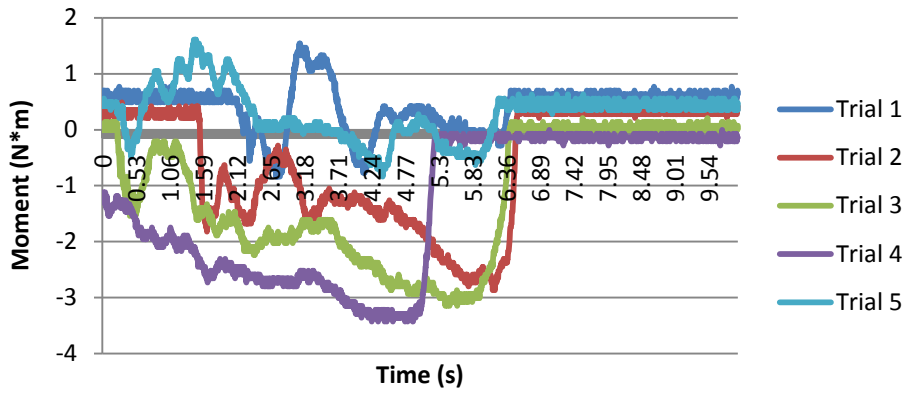

Mz for Green Handle: Clockwise Elliptical Incision

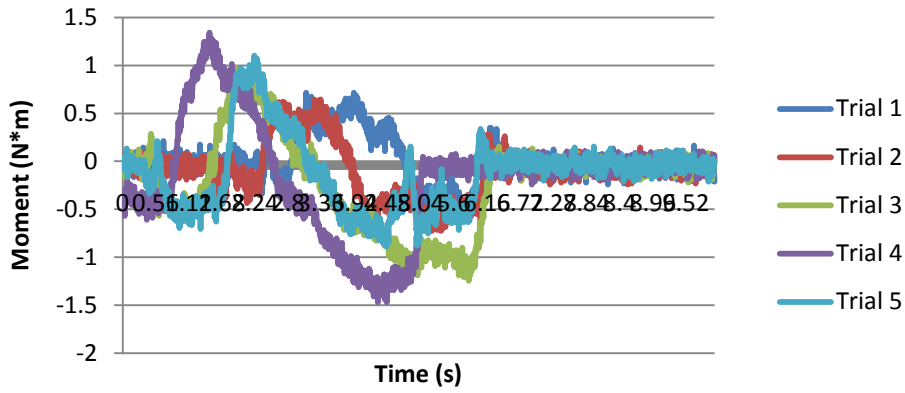

Average Fx for Green Handle: Clockwise Elliptical Incision

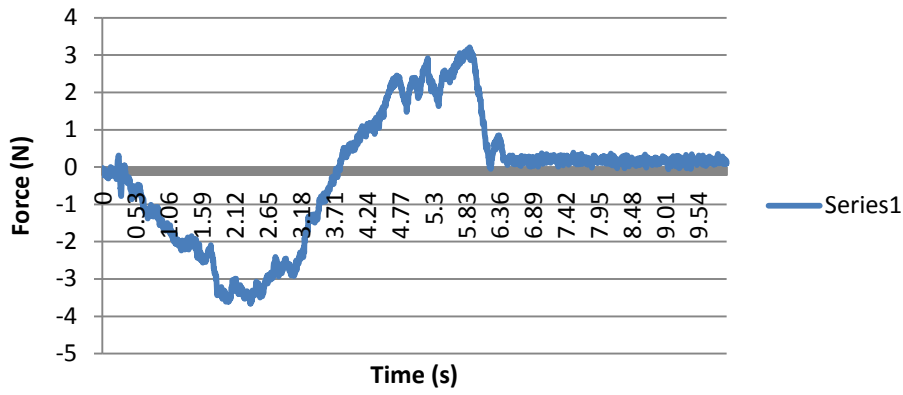

Average Fy for Green Handle: Clockwise Elliptical Incision

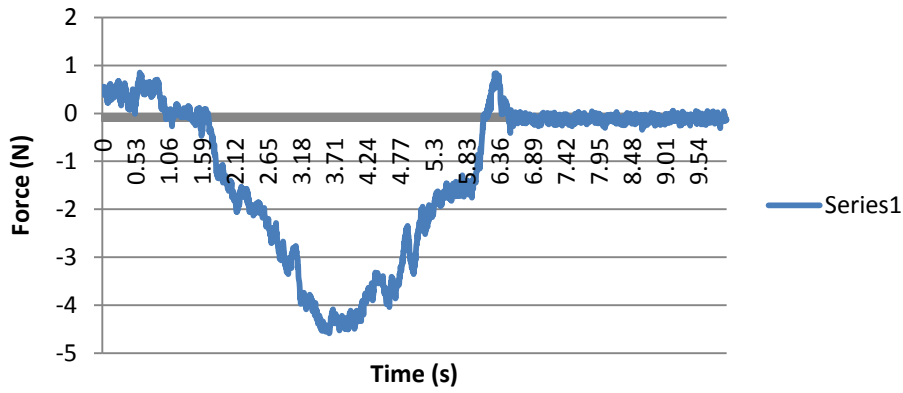

Average Fz for Green Handle: Clockwise Elliptical Incision

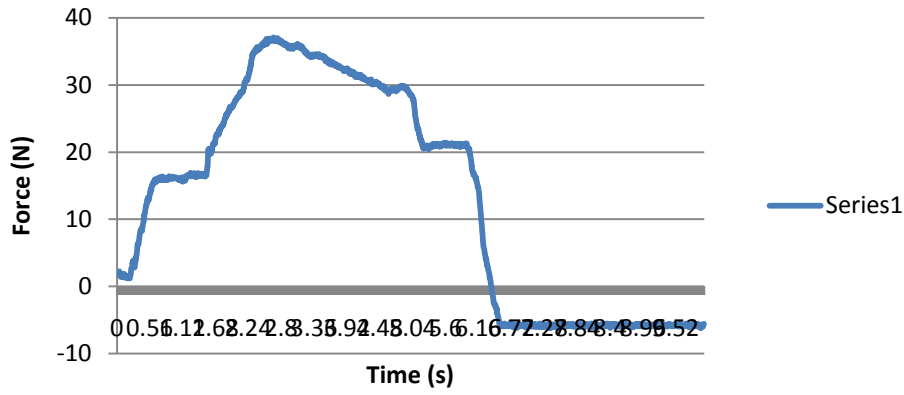

Average Mx for Green Handle: Clockwise Elliptical Incision

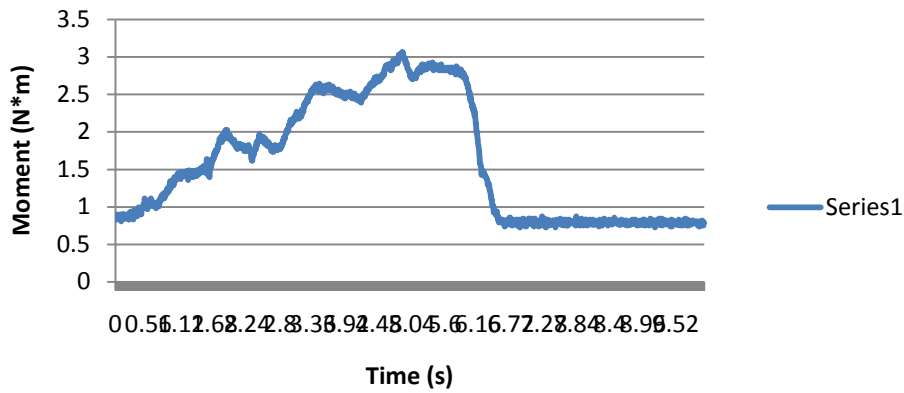

Average My for Green Handle: Clockwise Elliptical Incision

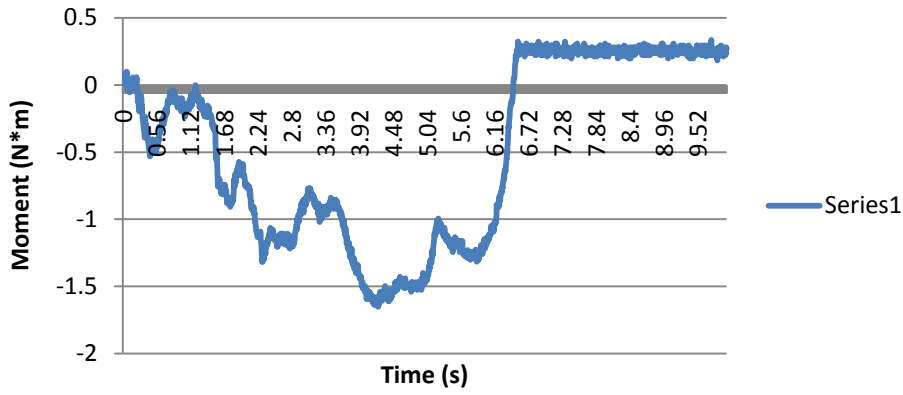

Average Mz for Green Handle: Clockwise Elliptical Incision

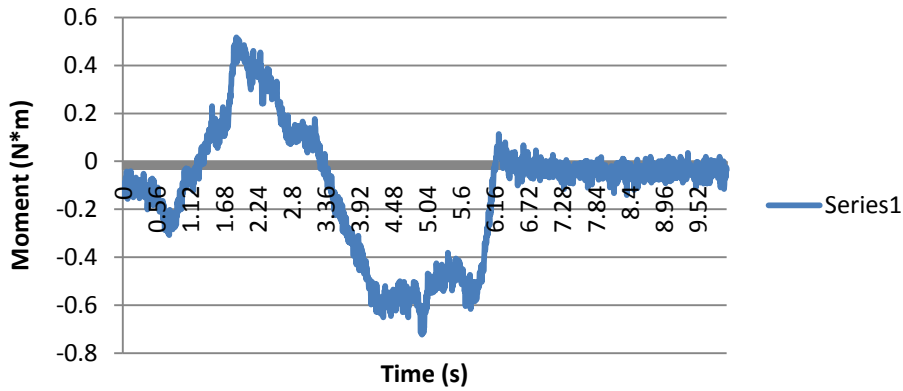

Fx for Green Handle: Horizontal Linear Incision

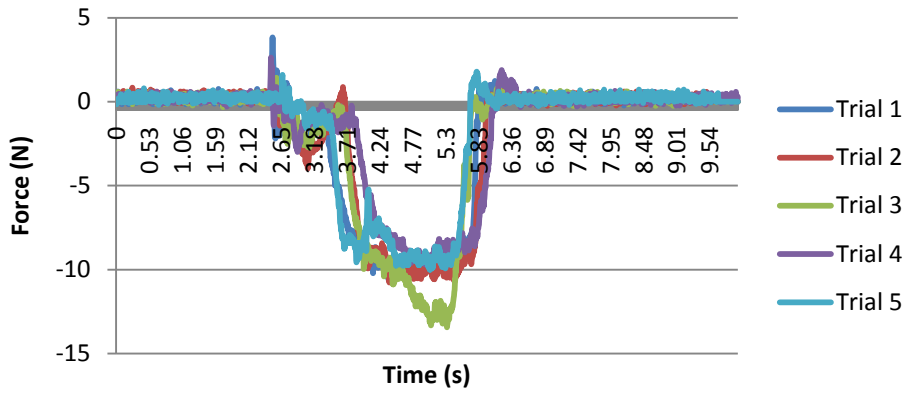

Fy for Green Handle: Horizontal Linear Incision

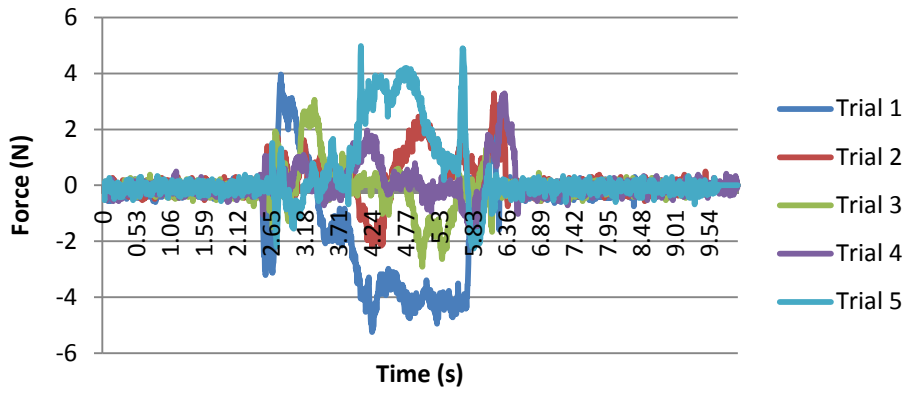

Fz for Green Handle: Horizontal Linear Incision

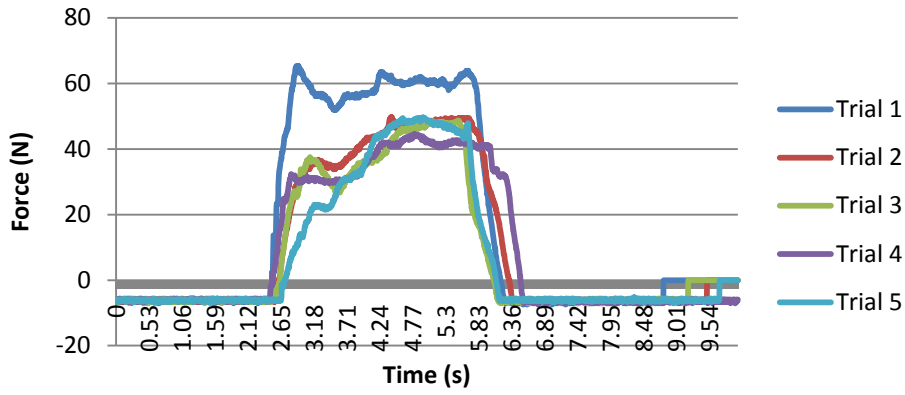

Mx for Green Handle: Horizontal Linear Incision

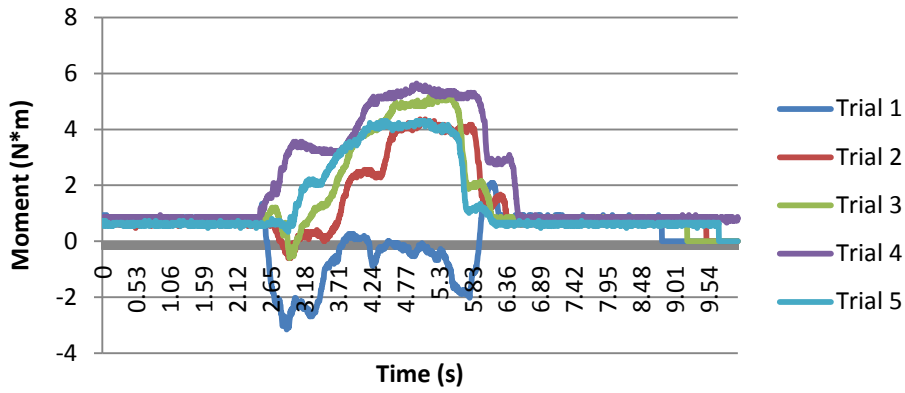

My for Green Handle: Horizontal Linear Incision

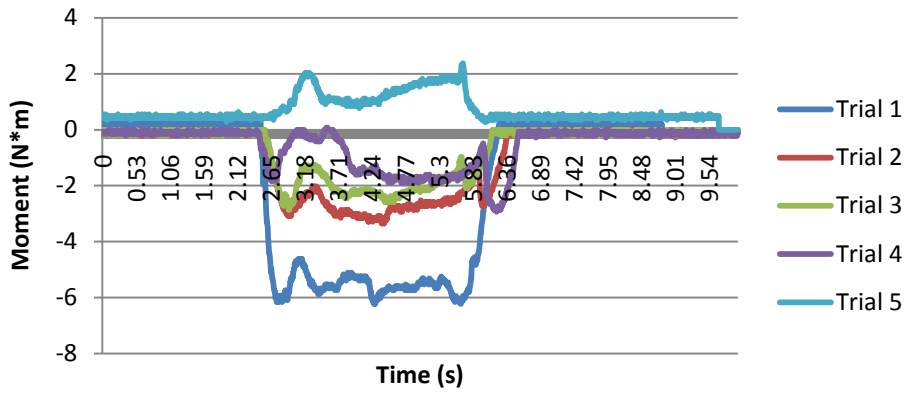

Mz for Green Handle: Horizontal Linear Incision

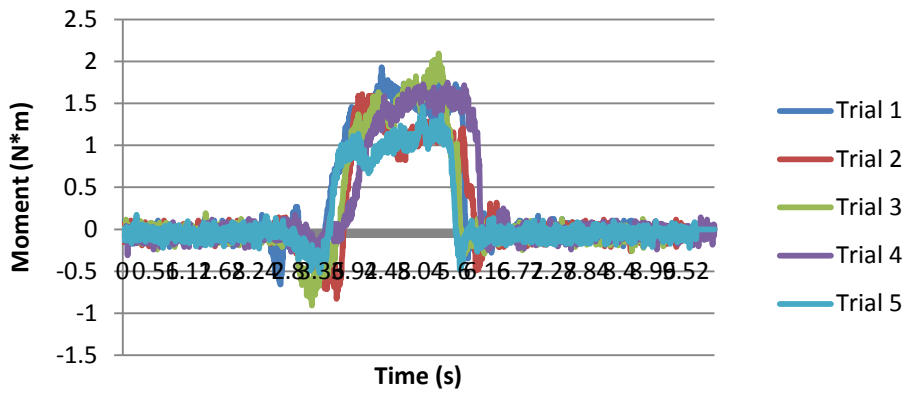

Average Fx for Green Handle: Horizontal Linear Incision

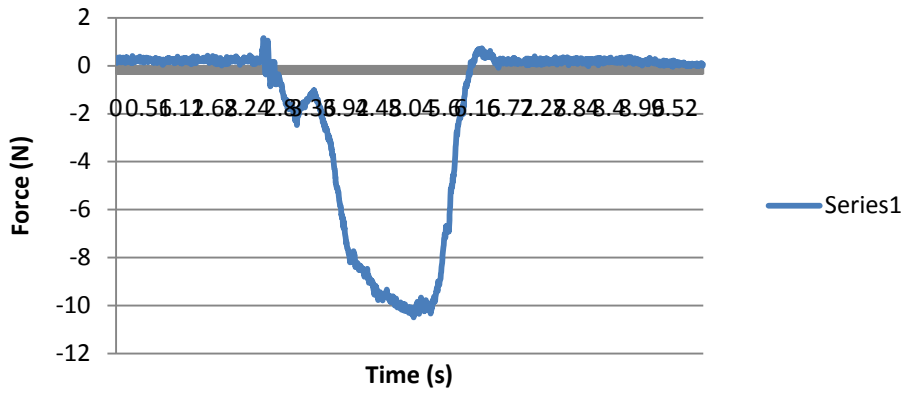

Average Fy for Green Handle: Horizontal Linear Incision

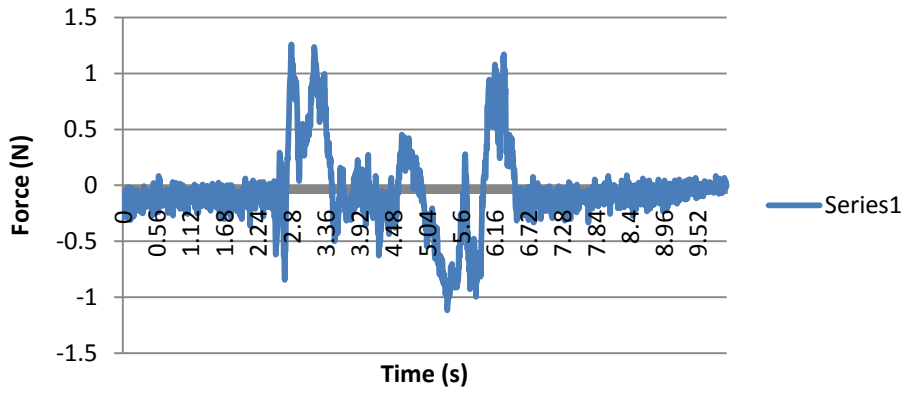

Average Fz for Green Handle: Horizontal Linear Incision

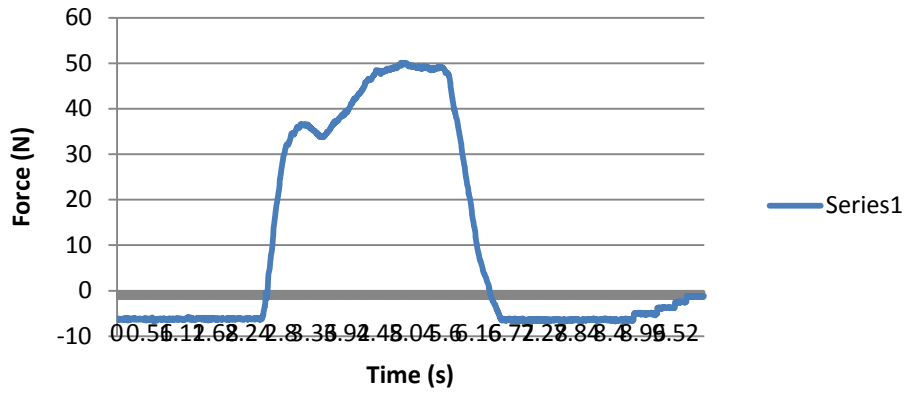

Average Mx for Green Handle: Horizontal Linear Incision

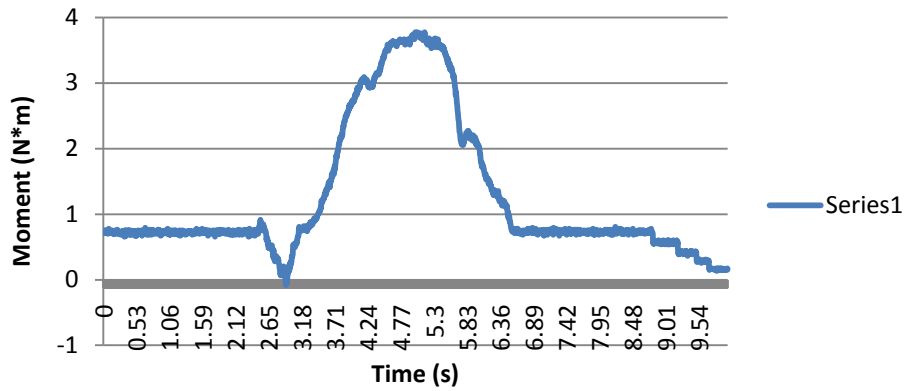

Average My for Green Handle: Horizontal Linear Incision

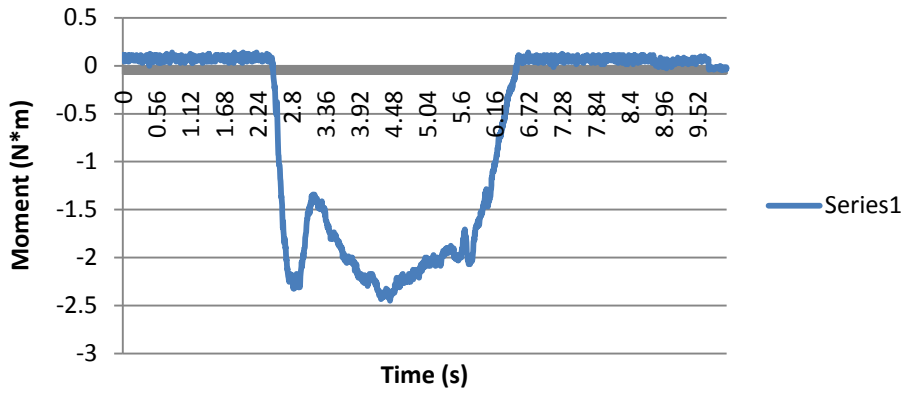

Average Mz for Green Handle: Horizontal Linear Incision

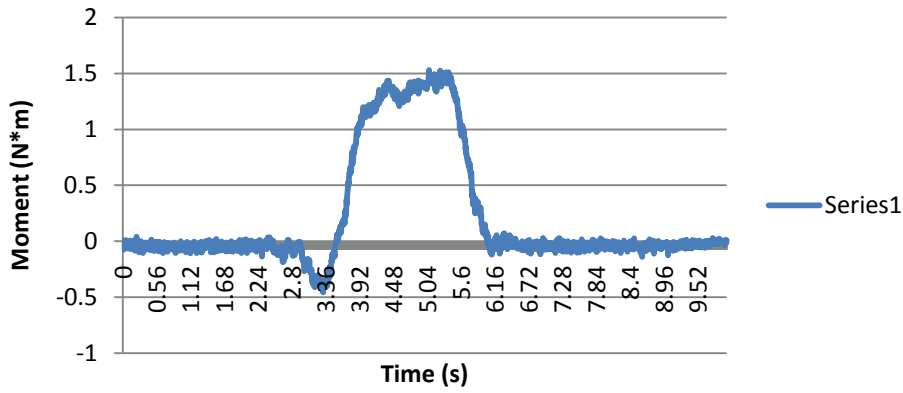

Fx for Green Handle: Vertical Linear Incision

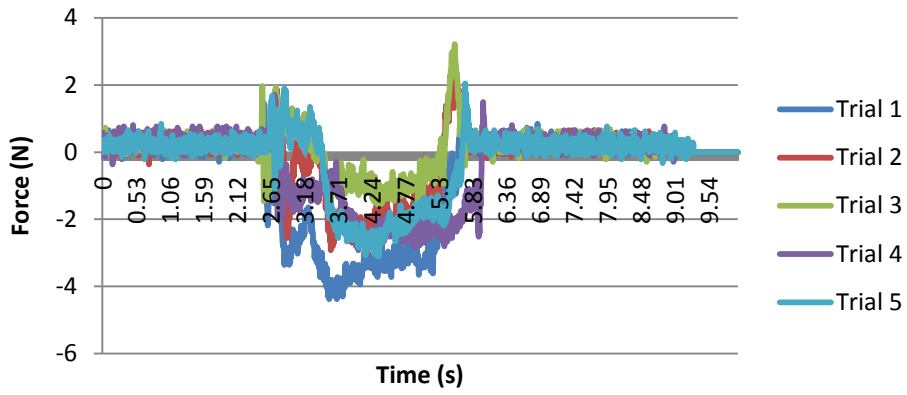

Fy for Green Handle: Vertical Linear Incision

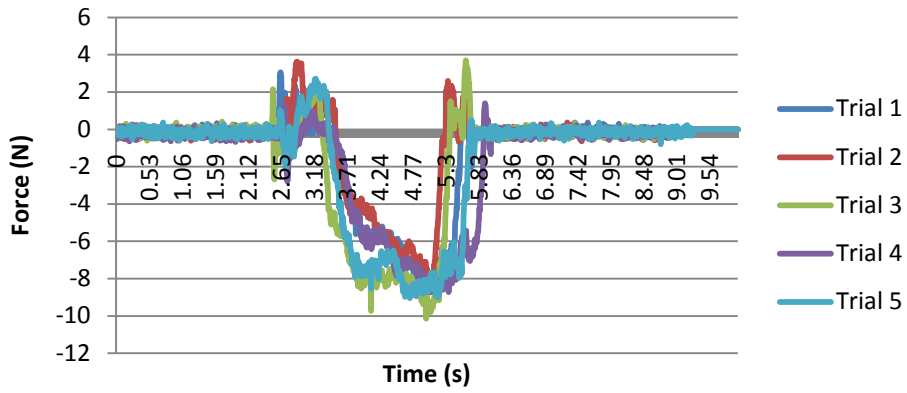

Fz for Green Handle: Vertical Linear Incision

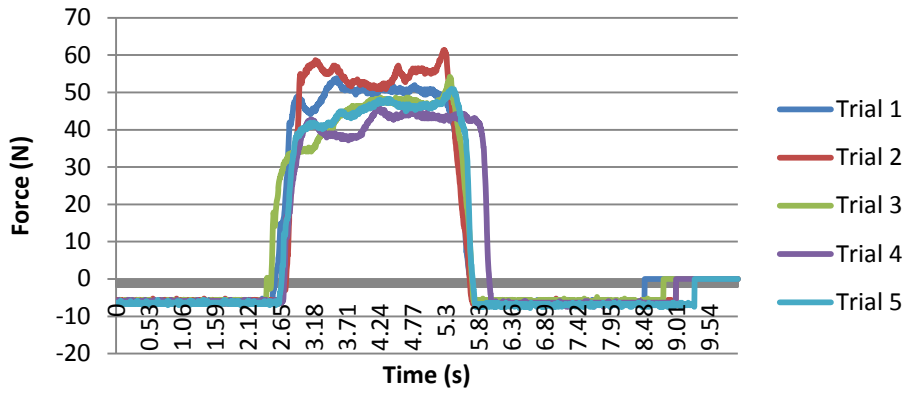

Mx for Green Handle: Vertical Linear Incision

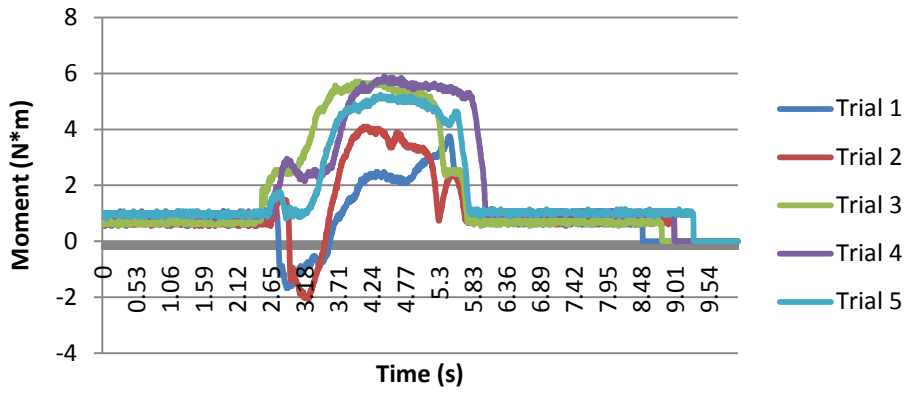

My for Green Handle: Vertical Linear Incision

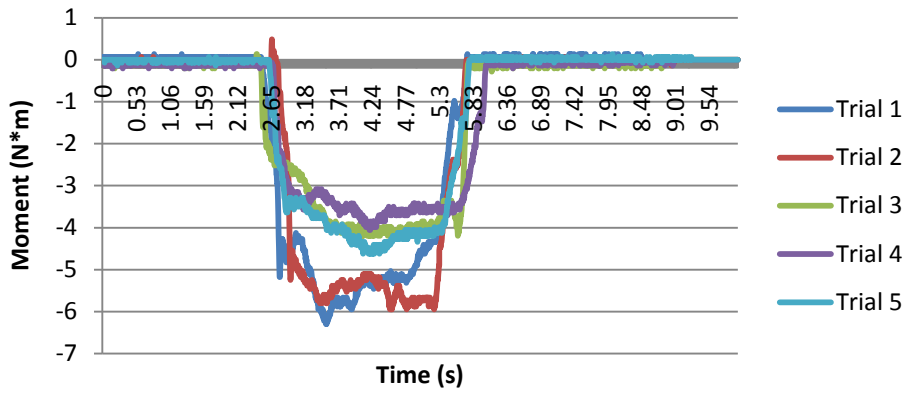

Mz for Green Handle: Vertical Linear Incision

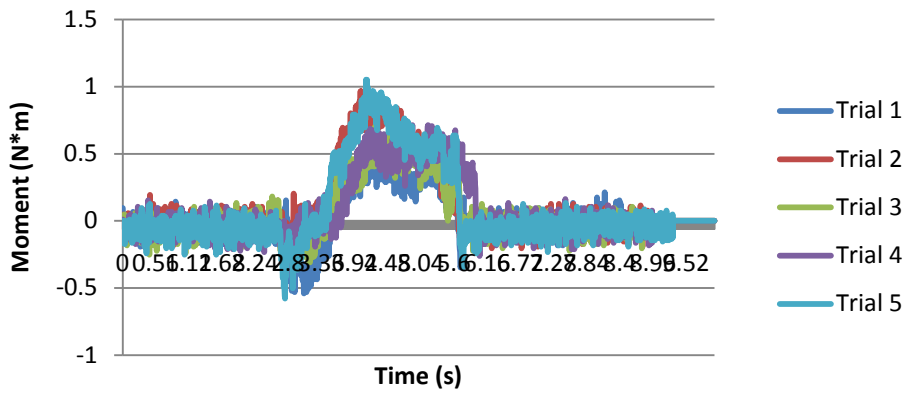

Average Fx for Green Handle: Vertical Linear Incision

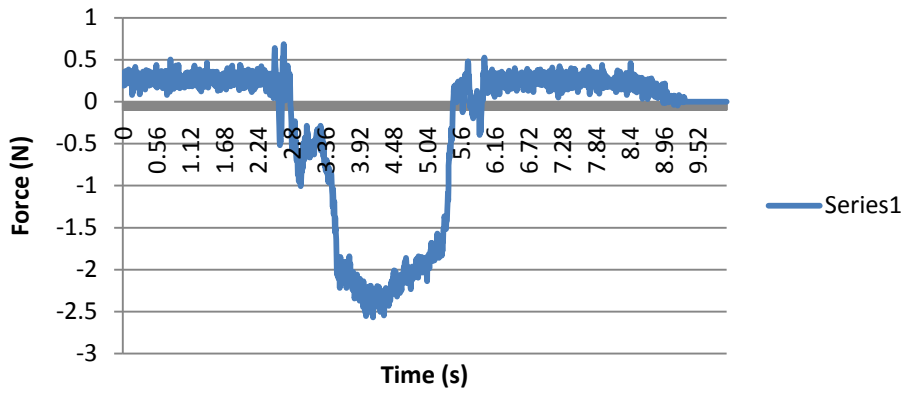

Average Fy for Green Handle: Vertical Linear Incision

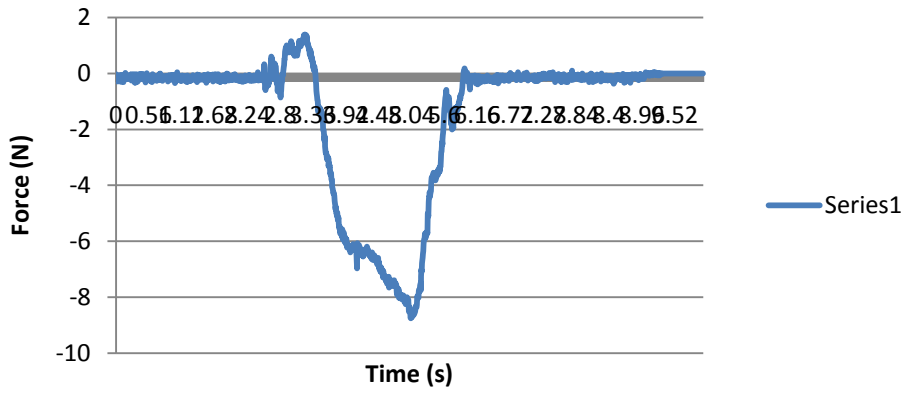

Average Fz for Green Handle: Vertical Linear Incision

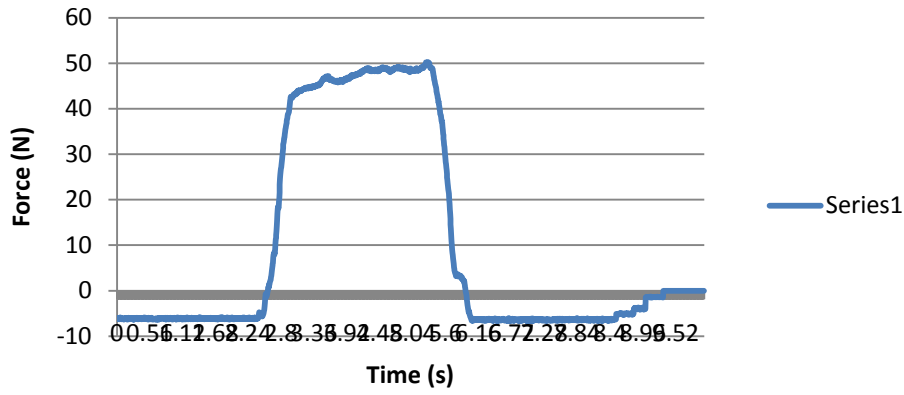

Average Mx for Green Handle: Vertical Linear Incision

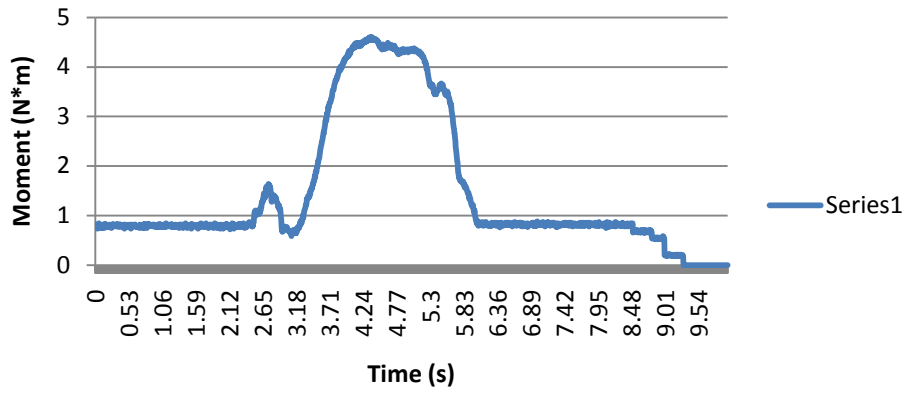

Average My for Green Handle: Vertical Linear Incision

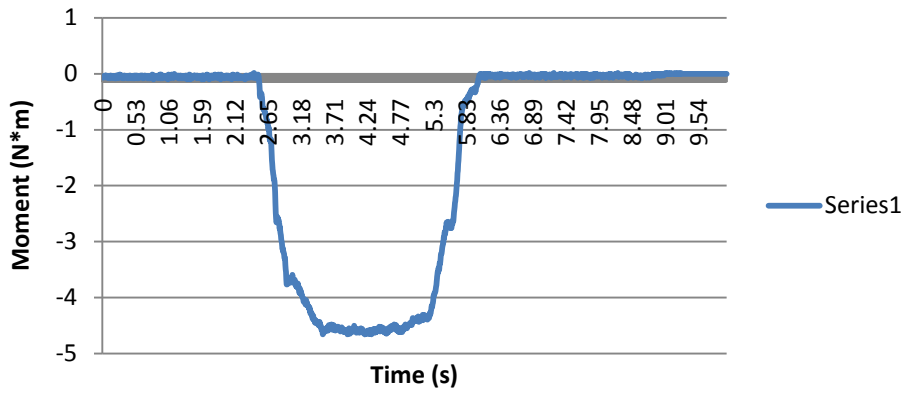

Average Mz for Green Handle: Vertical Linear Incision

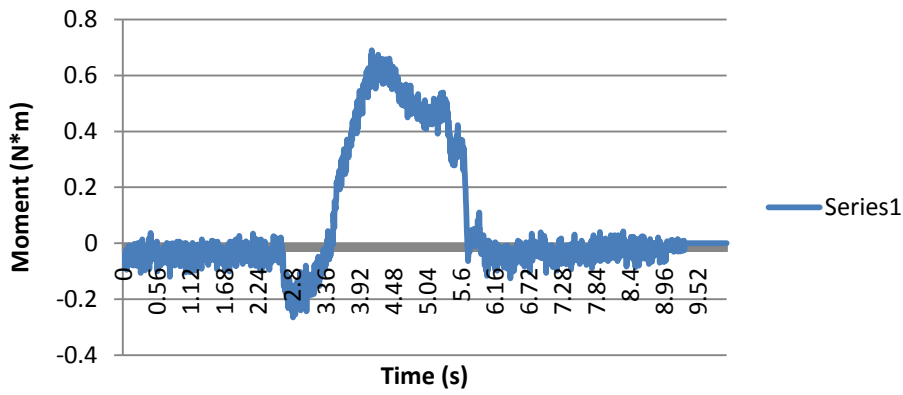

Fx for Ergonomic Handle: Counterclockwise Circular Incision

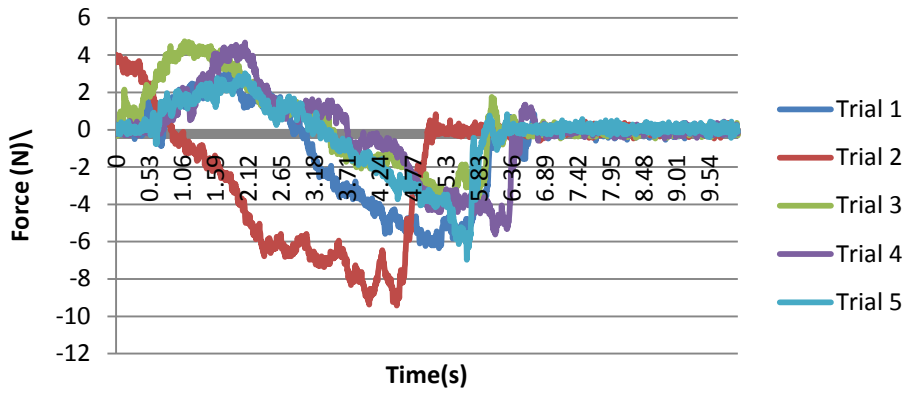

Fy for Ergonomic Handle: Counterclockwise Circular Incision

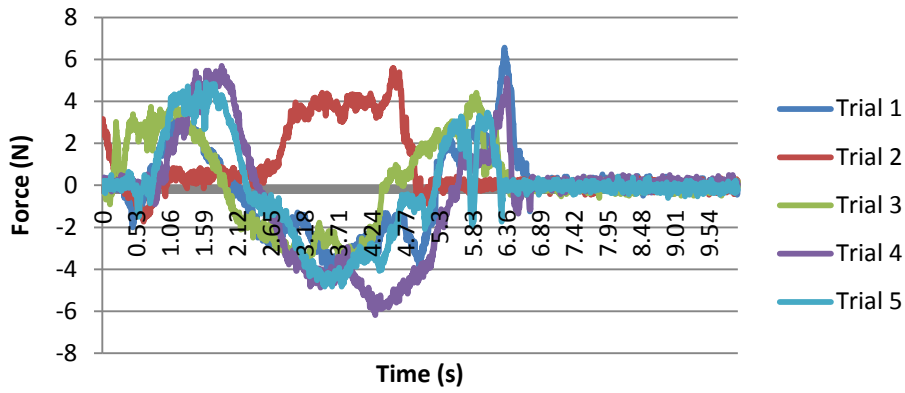

Fz for Ergonomic Handle: Counterclockwise Circular Incision

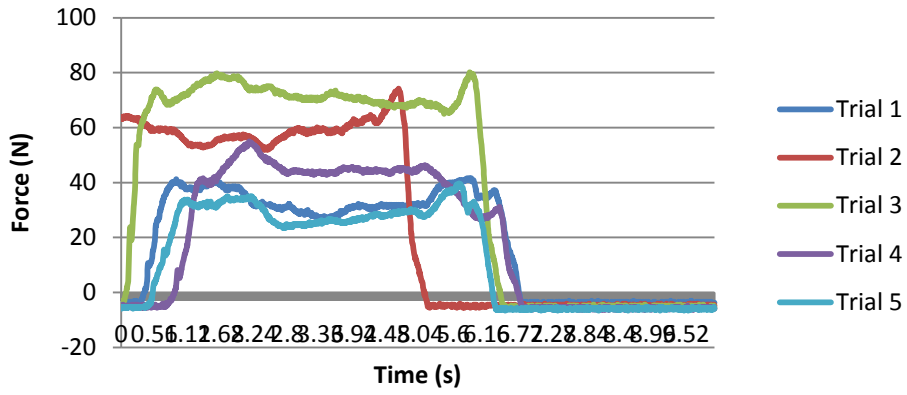

Mx for Ergonomic Handle: Counterclockwise Circular Incision

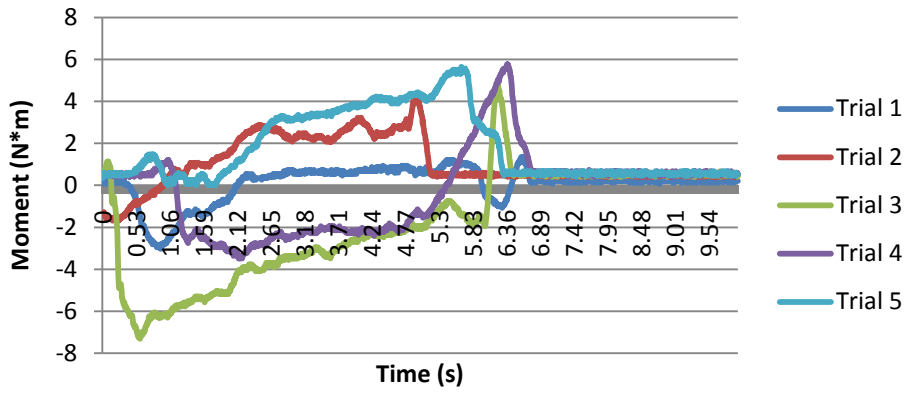

My for Ergonomic Handle: Counterclockwise Circular Incision

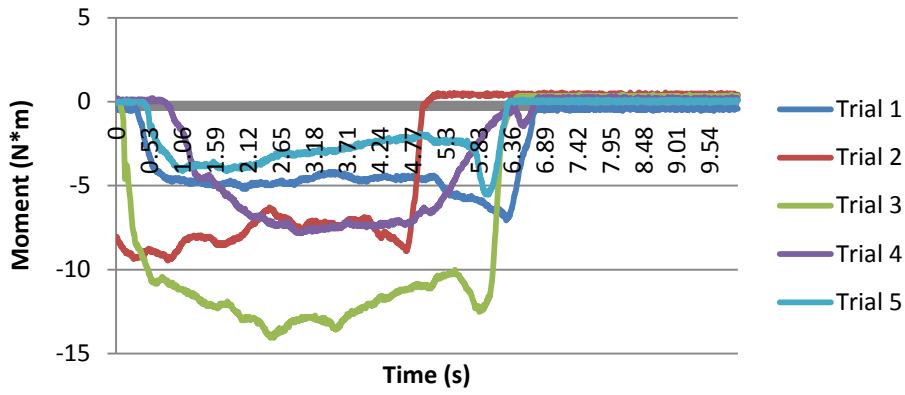

Mz for Ergonomic Handle: Counterclockwise Circular Incision

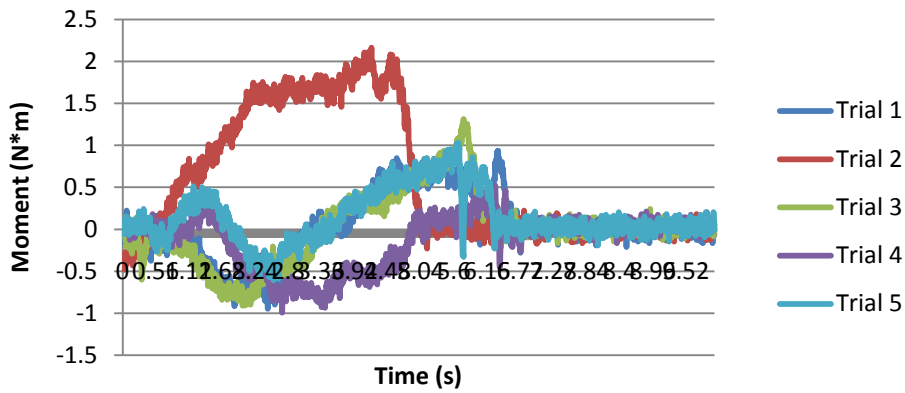

Average Fx for Ergonomic Handle: Counterclockwise Circular Incision

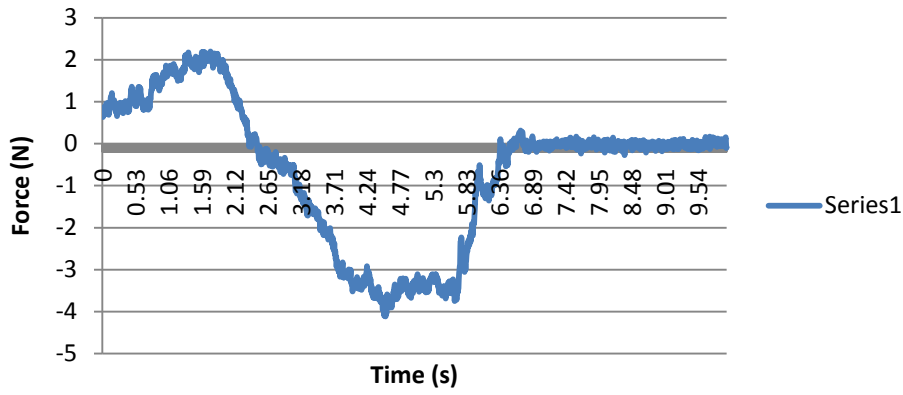

Average Fy for Ergonomic Handle: Counterclockwise Circular Incision

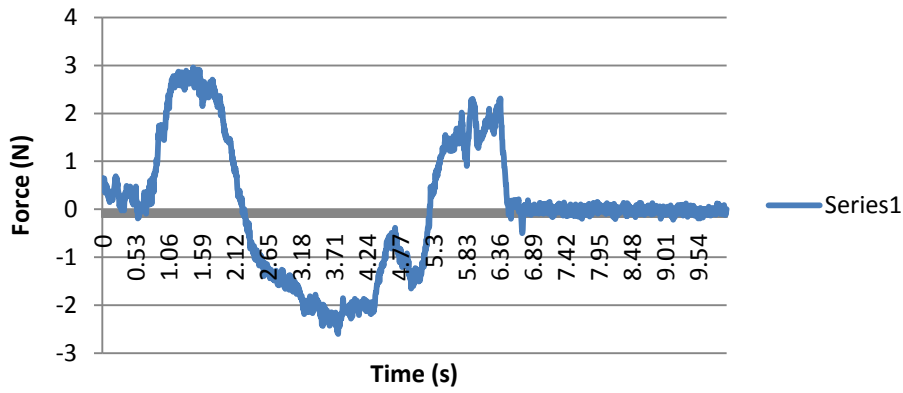

Average Fz for Ergonomic Handle: Counterclockwise Circular Incision

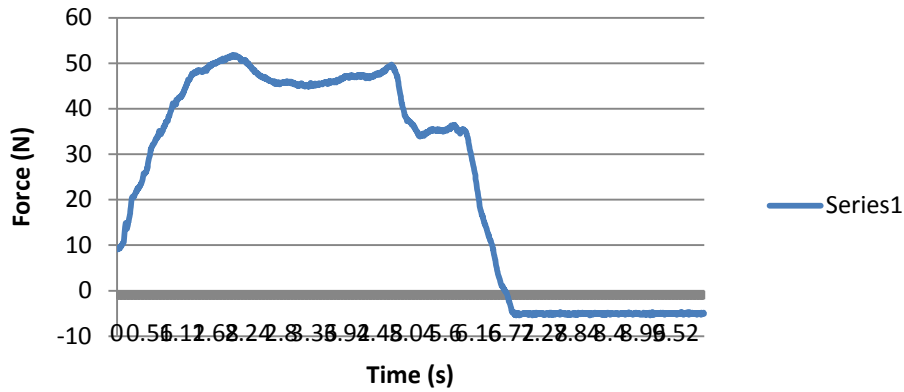

Average Mx for Ergonomic Handle: Counterclockwise Circular Incision

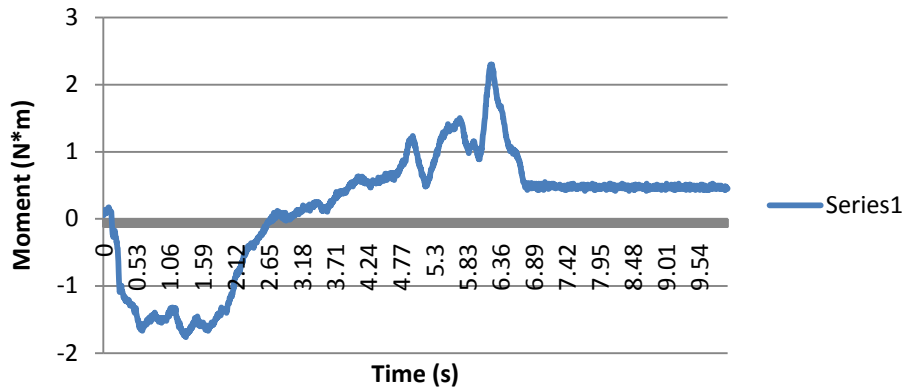

Average My for Ergonomic Handle: Counterclockwise Circular Incision

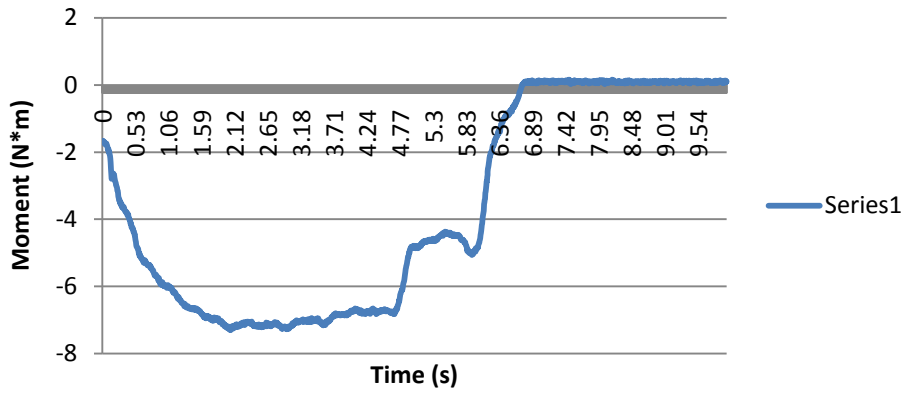

Average Mz for Ergonomic Handle: Counterclockwise Circular Incision

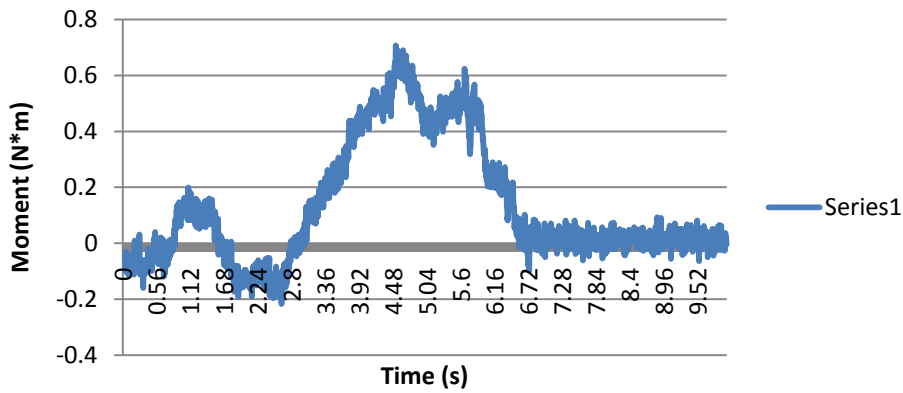

Fx for Ergonomic Handle: Clockwise Circular Incision

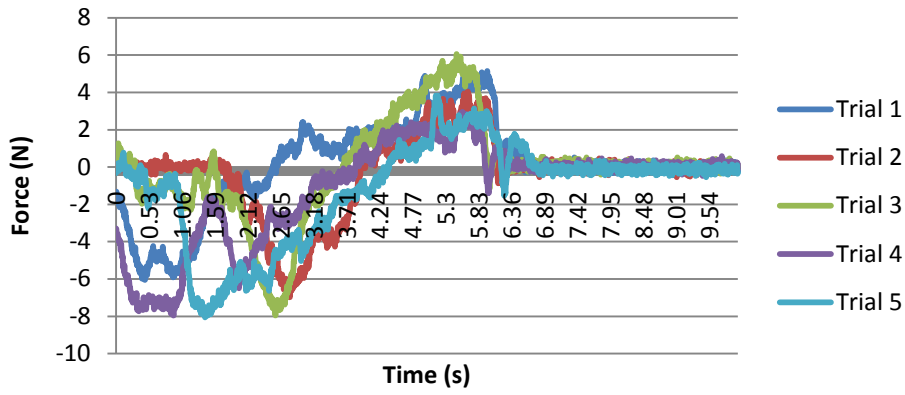

Fy for Ergonomic Handle: Clockwise Circular Incision

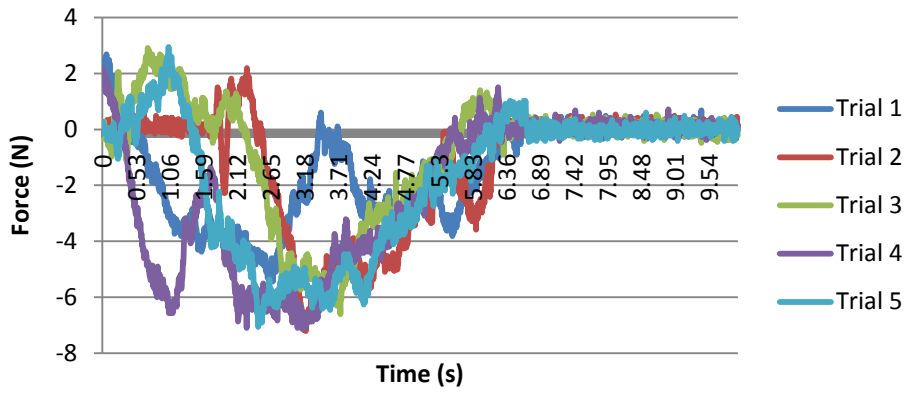

Fz for Ergonomic Handle: Clockwise Circular Incision

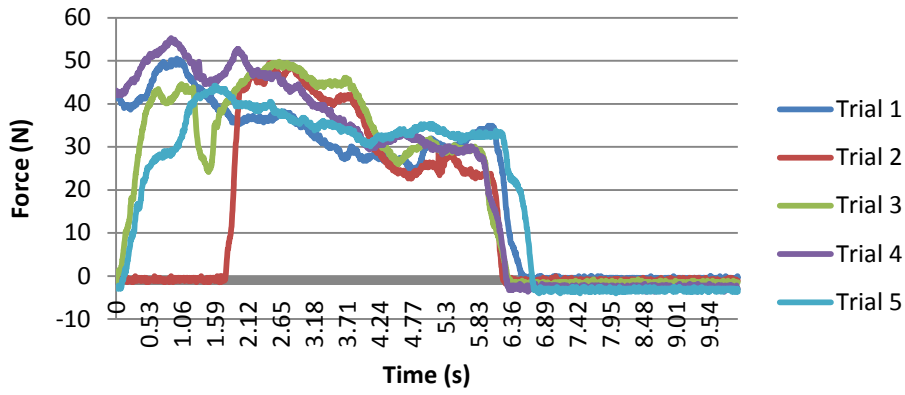

Mx for Ergonomic Handle: Clockwise Circular Incision

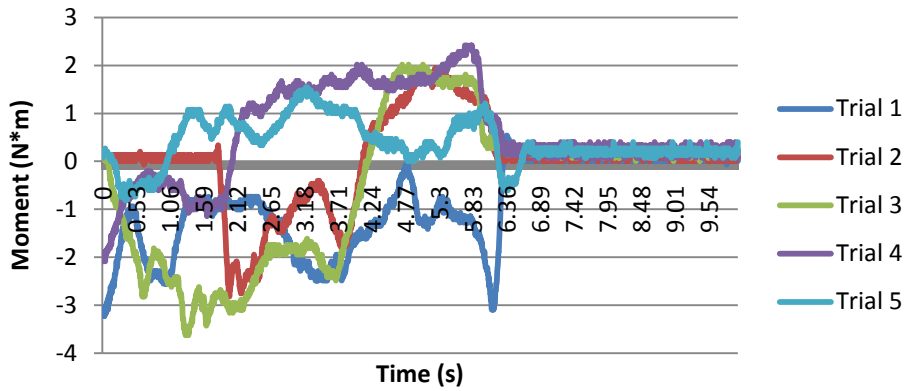

My for Ergonomic Handle: Clockwise Circular Incision

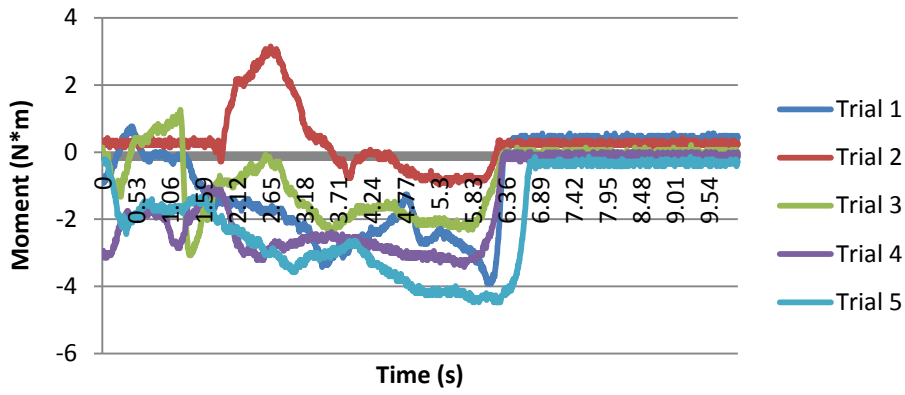

Mz for Ergonomic Handle: Clockwise Circular Incision

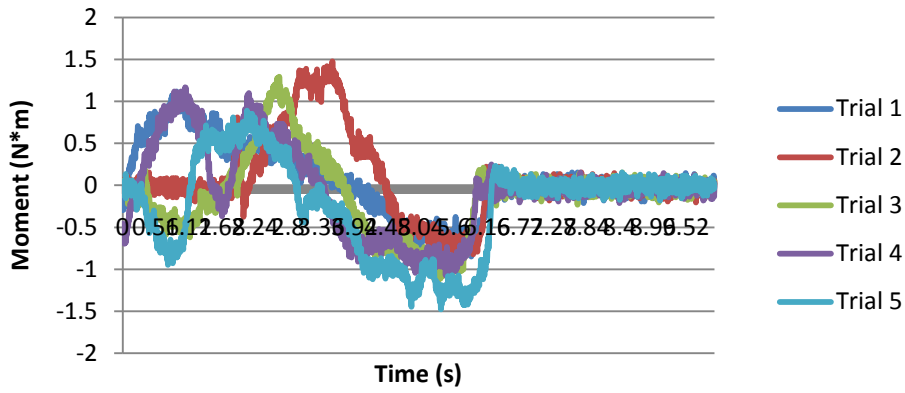

Average Fx for Ergonomic Handle: Clockwise Circular Incision

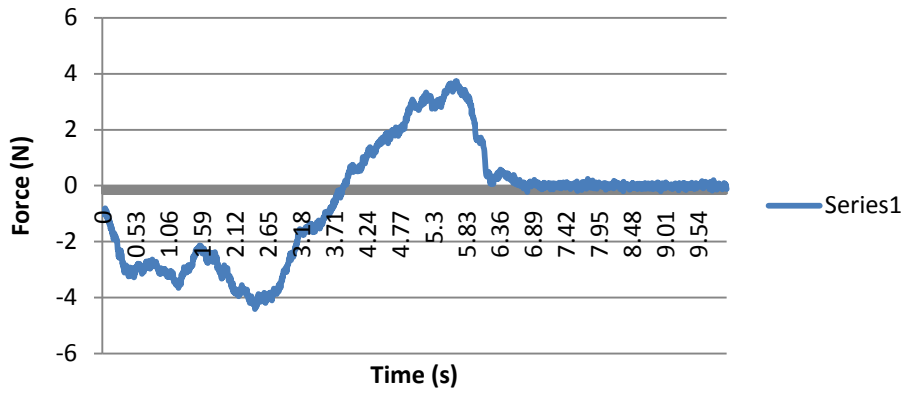

Average Fy for Ergonomic Handle: Clockwise Circular Incision

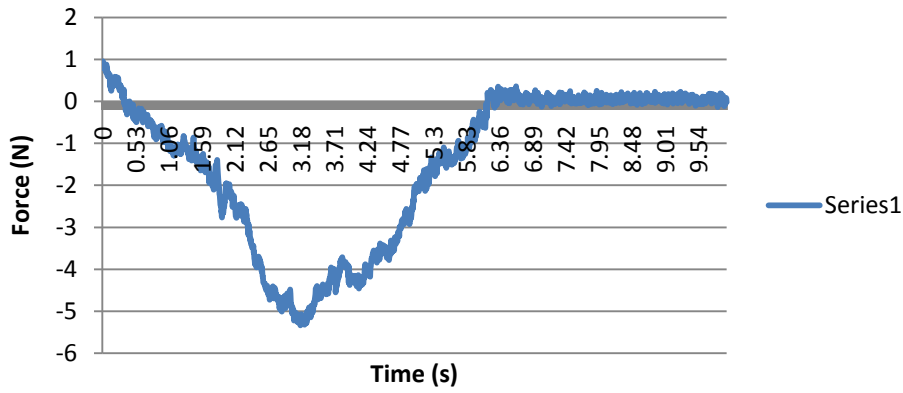

Average Fz for Ergonomic Handle: Clockwise Circular Incision

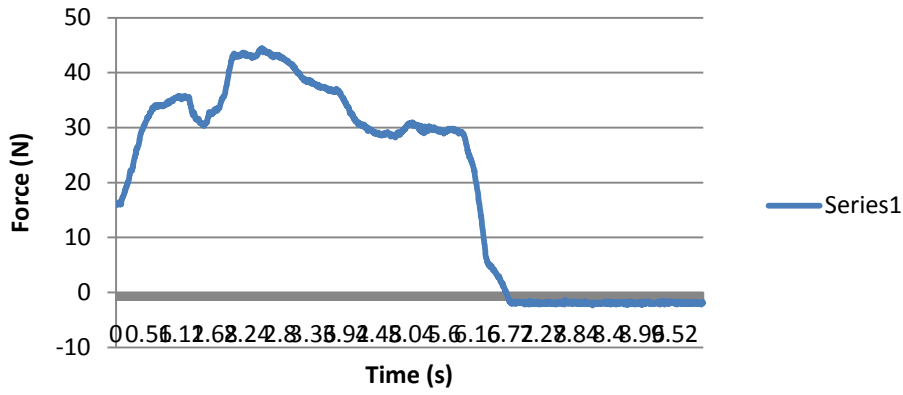

Average Mx for Ergonomic Handle: Clockwise Circular Incision

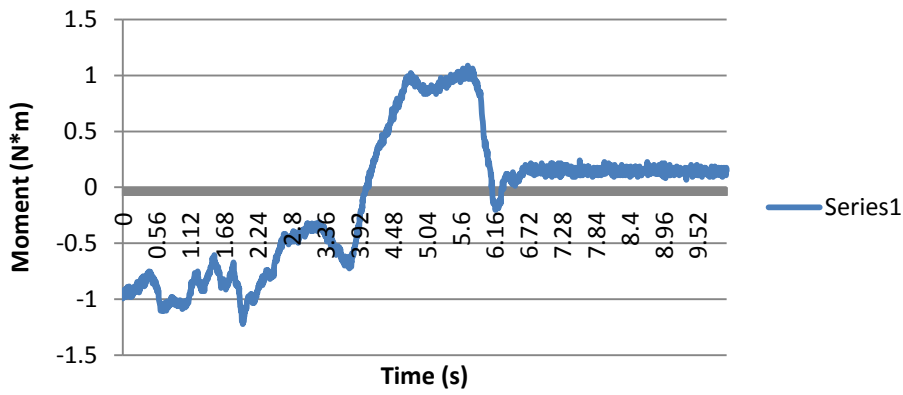

Average My for Ergonomic Handle: Clockwise Circular Incision

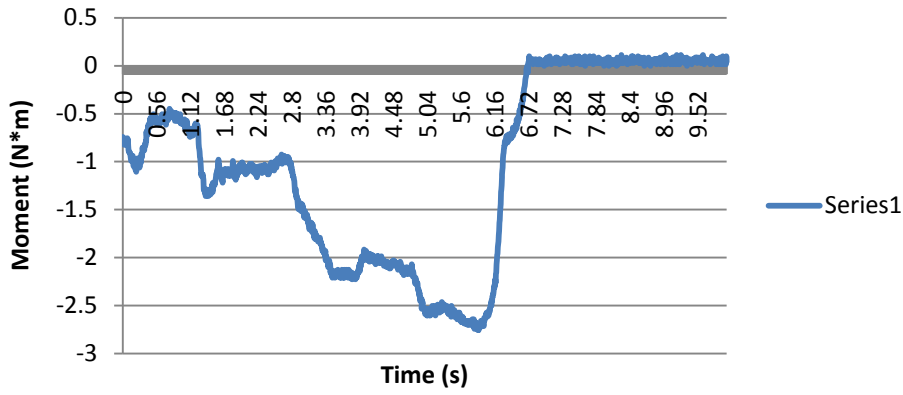

Average Mz for Ergonomic Handle: Clockwise Circular Incision

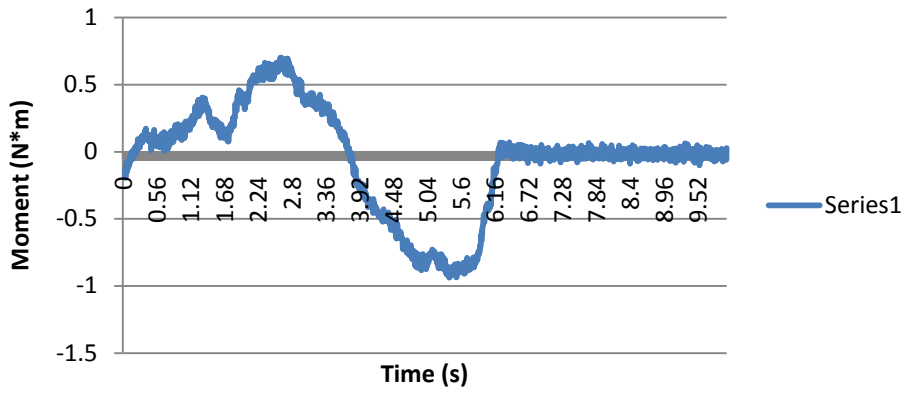

Fx for Ergonomic Handle: Counterclockwise Elliptical Incision

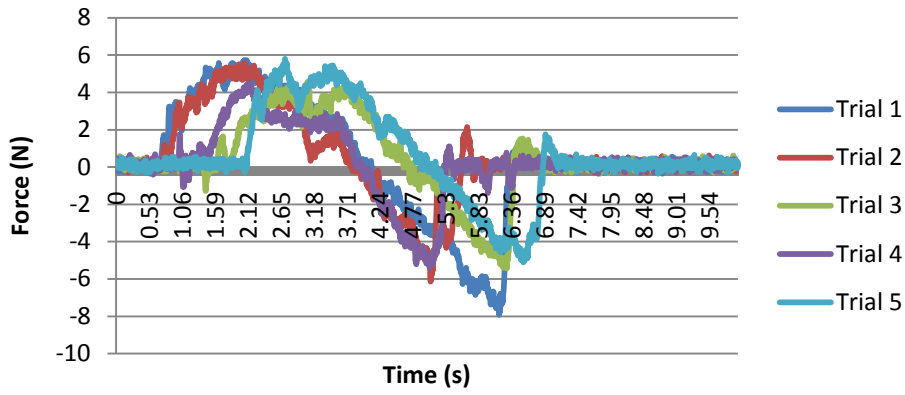

Fy for Ergonomic Handle: Counterclockwise Elliptical Incision

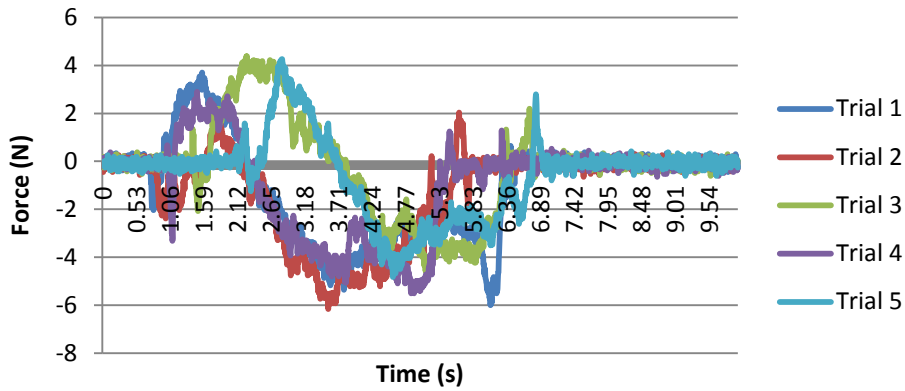

Fz for Ergonomic Handle: Counterclockwise Elliptical Incision

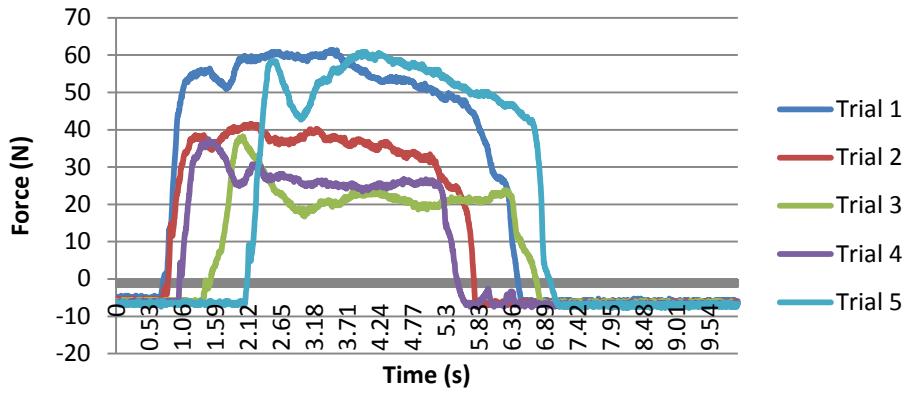

Mx for Ergonomic Handle: Counterclockwise Elliptical Incision

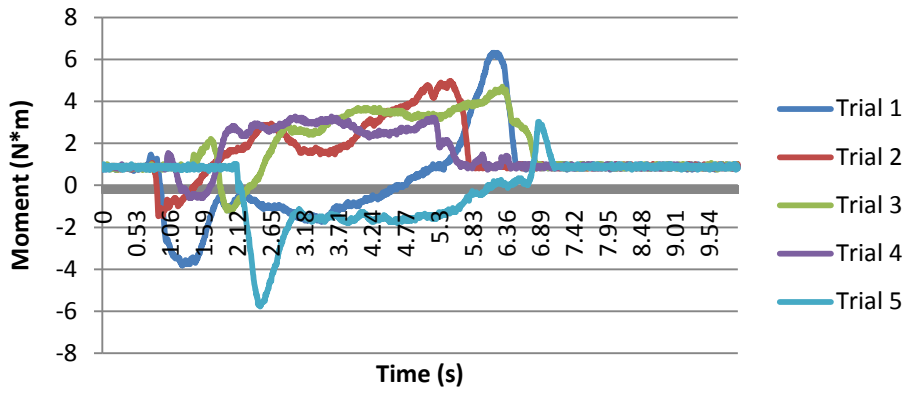

My for Ergonomic Handle: Counterclockwise Elliptical Incision

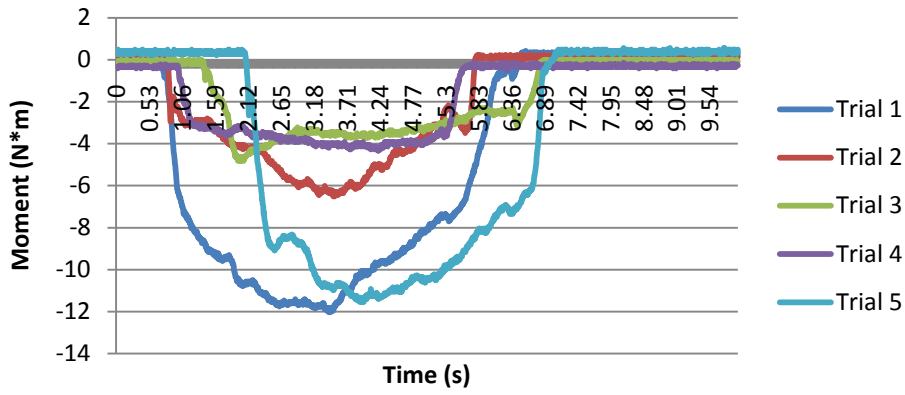

Mz for Ergonomic Handle: Counterclockwise Elliptical Incision

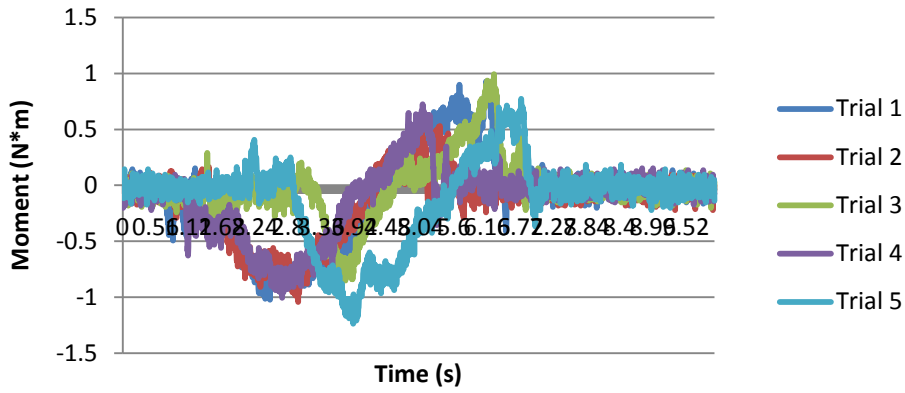

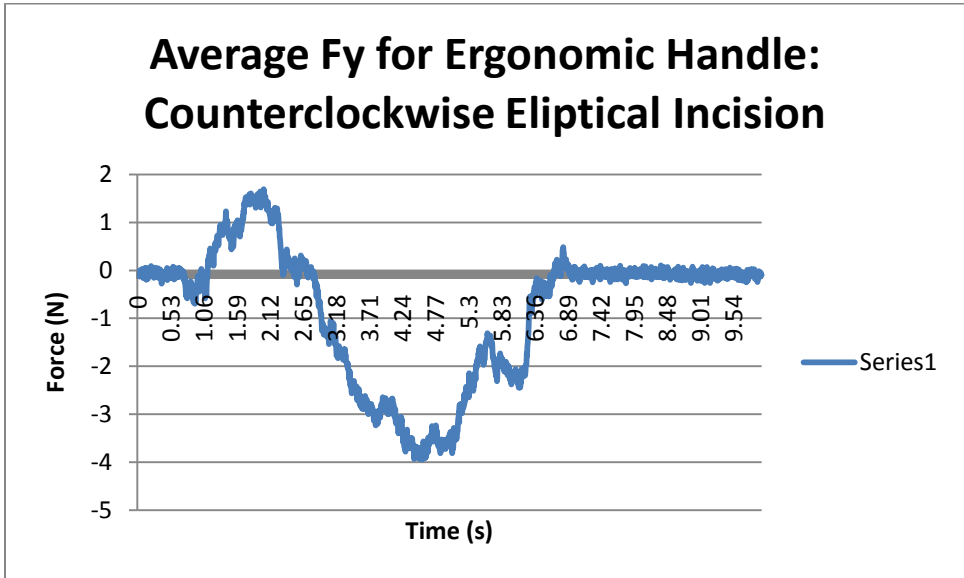
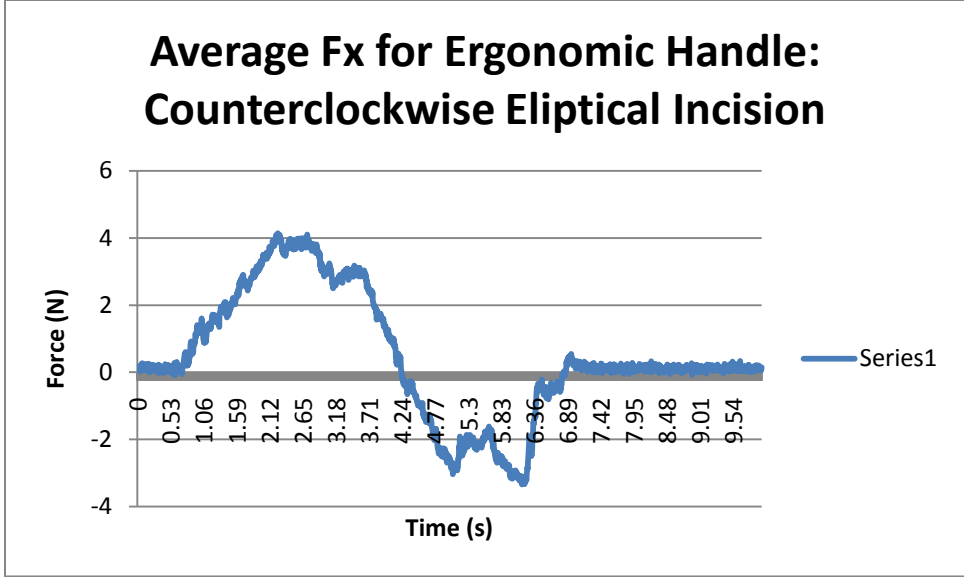

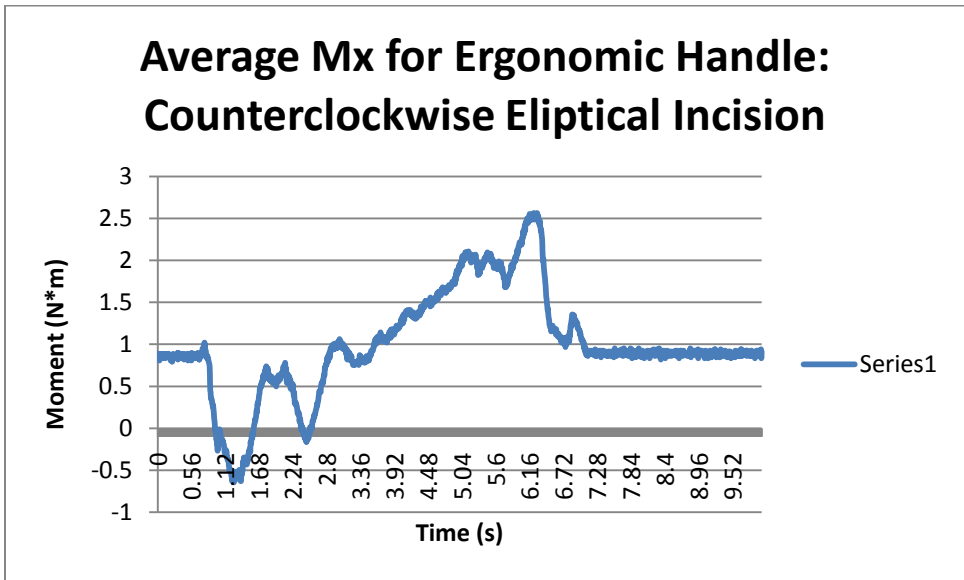
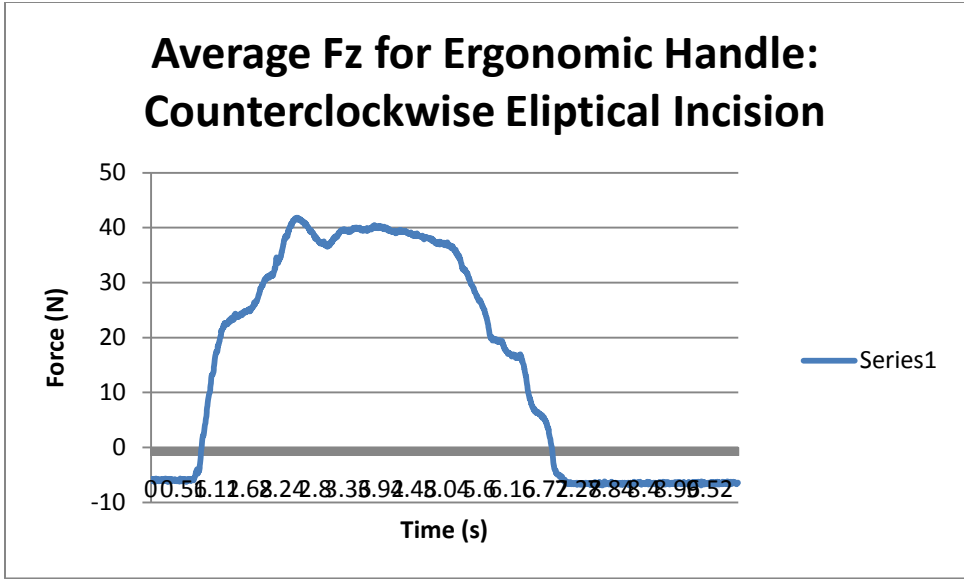

Average My for Ergonomic Handle: Counterclockwise Elliptical Incision

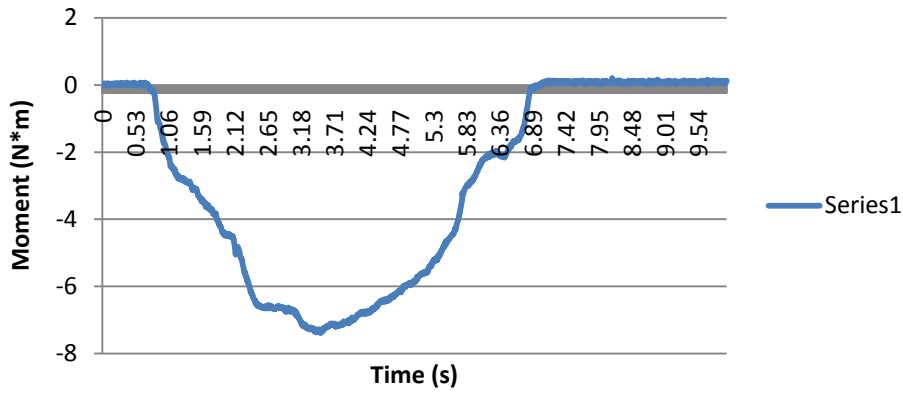

Average Mz for Ergonomic Handle: Counterclockwise Elliptical Incision

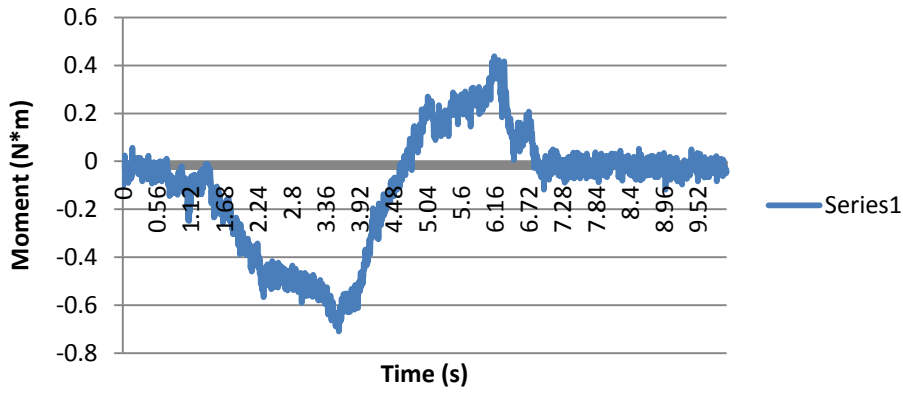

Fx for Ergonomic Handle: Clockwise Elliptical Incision

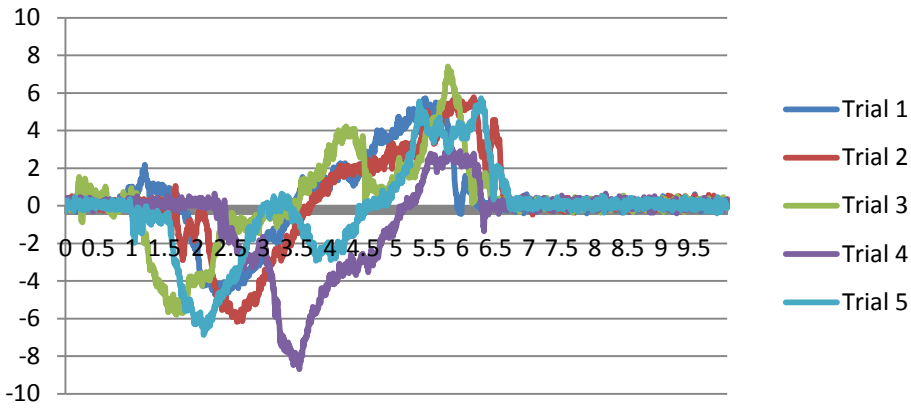

Fy for Ergonomic Handle: Clockwise Elliptical Incision

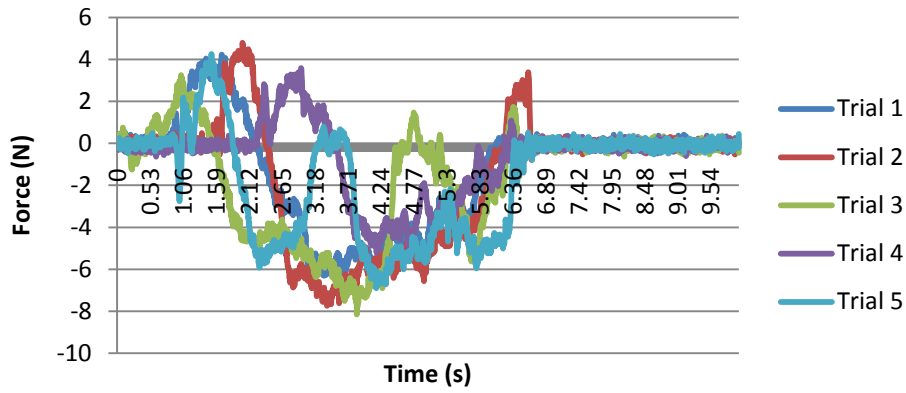

Fz for Ergonomic Handle: Clockwise Elliptical Incision

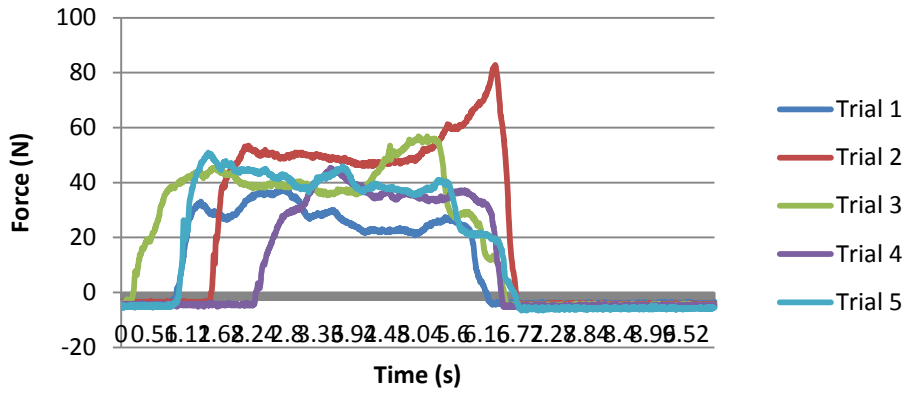

Mx for Ergonomic Handle: Clockwise Elliptical Incision

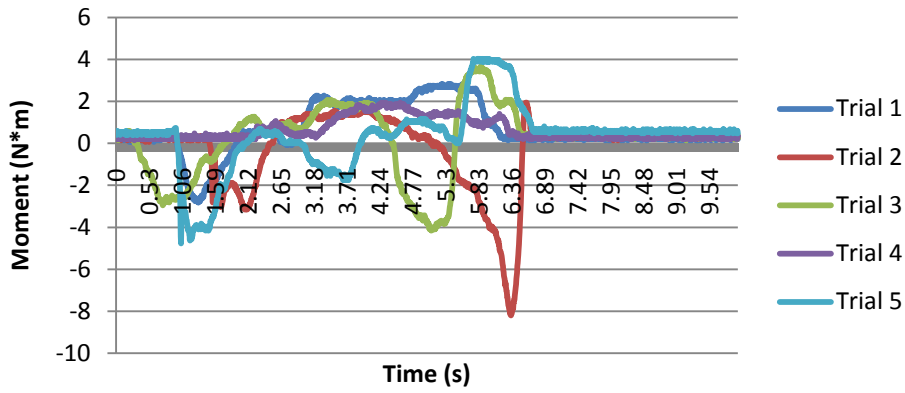

My for Ergonomic Handle: Clockwise Elliptical Incision

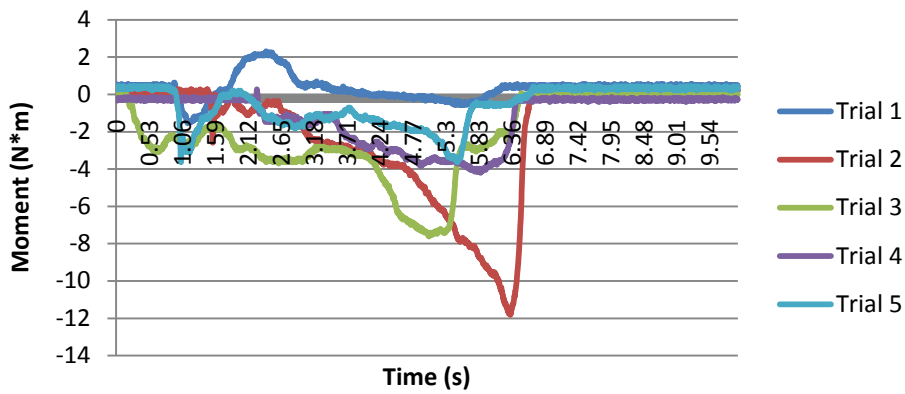

Mz for Ergonomic Handle: Clockwise Elliptical Incision

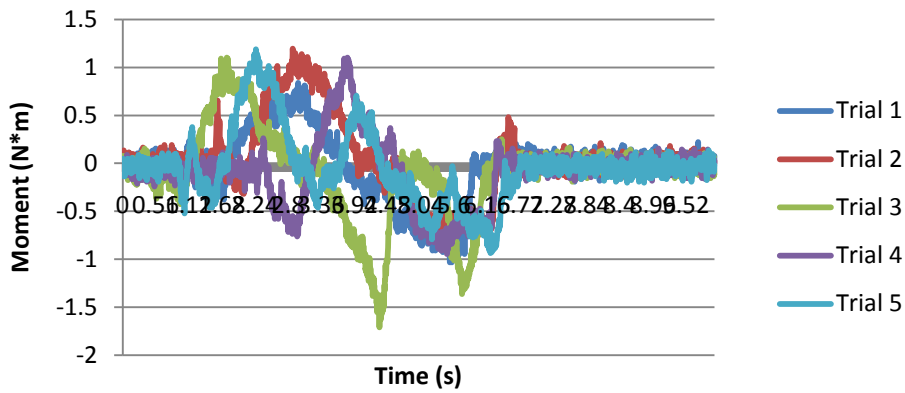

Average Fx for Ergonomic Handle: Clockwise Elliptical Incision

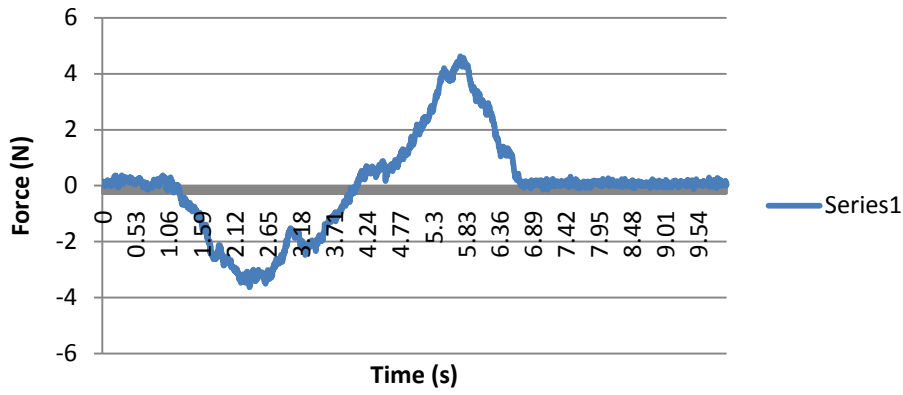

Average Fy for Ergonomic Handle: Clockwise Elliptical Incision

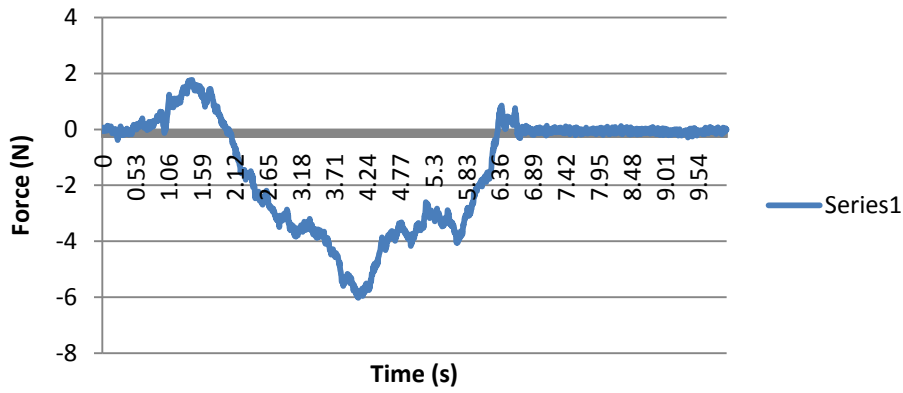

Average Fz for Ergonomic Handle: Clockwise Elliptical Incision

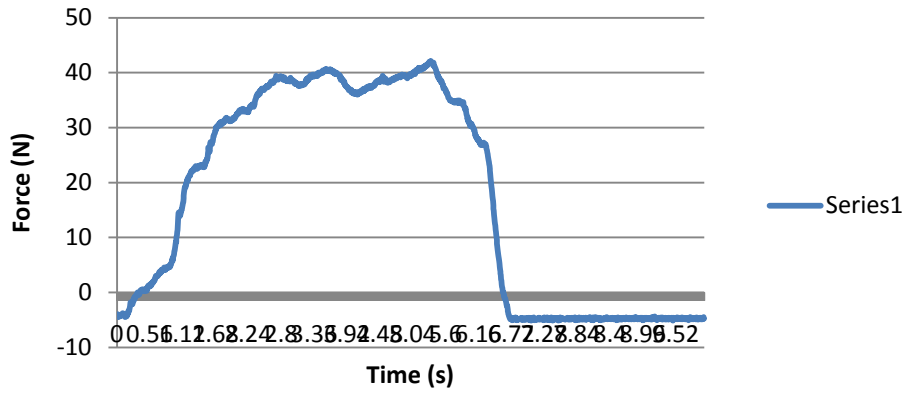

Average Mx for Ergonomic Handle: Clockwise Elliptical Incision

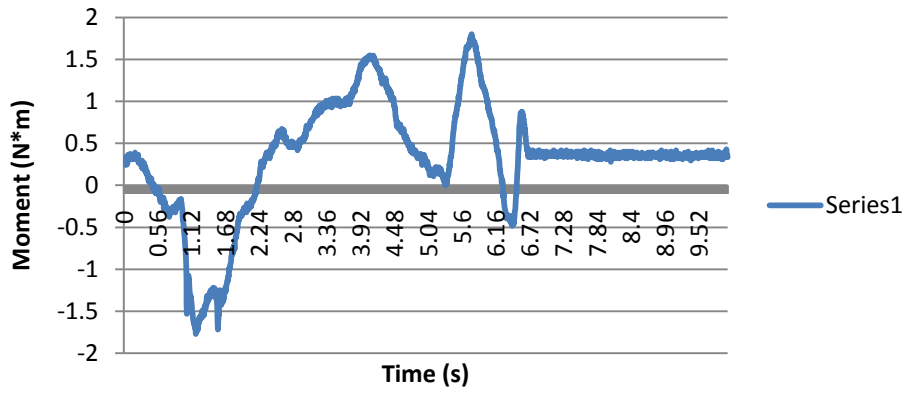

Average My for Ergonomic Handle: Clockwise Elliptical Incision

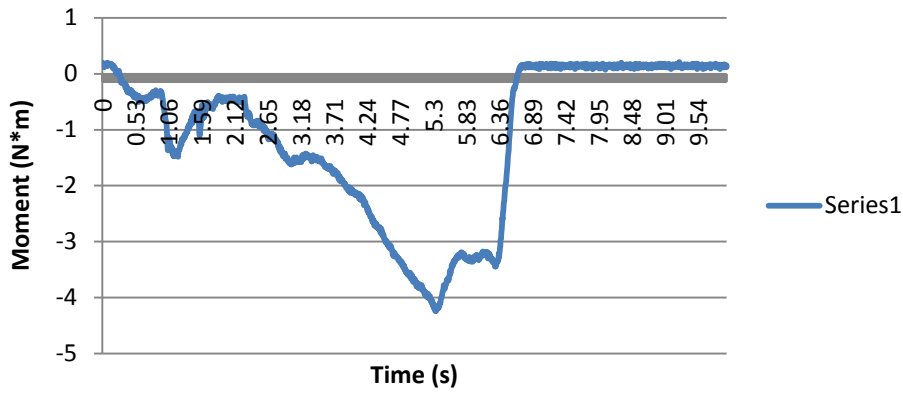

Average Mz for Ergonomic Handle: Clockwise Elliptical Incision

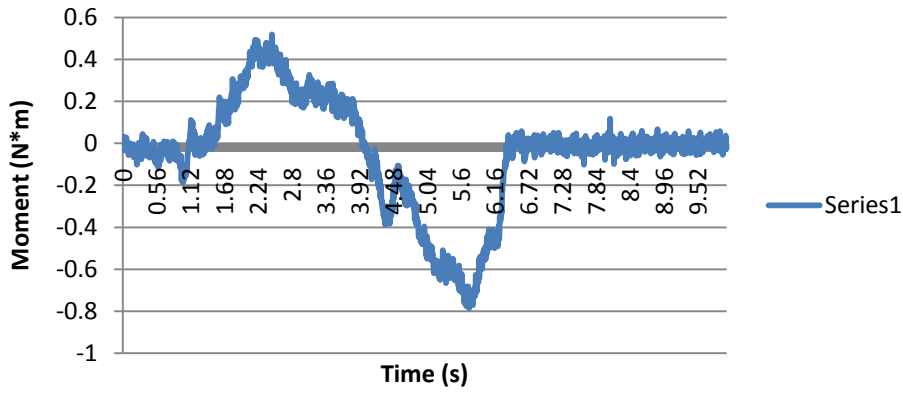

Fx for Ergonomic Handle: Horizontal Linear Incision

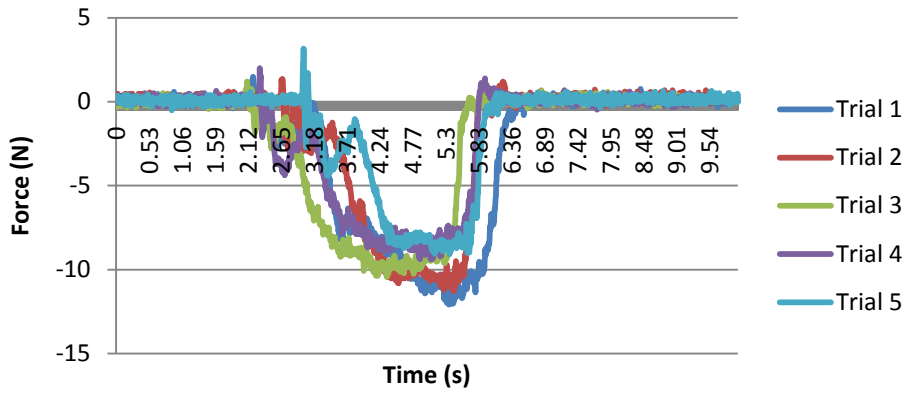

Fy for Ergonomic Handle: Horizontal Linear Incision

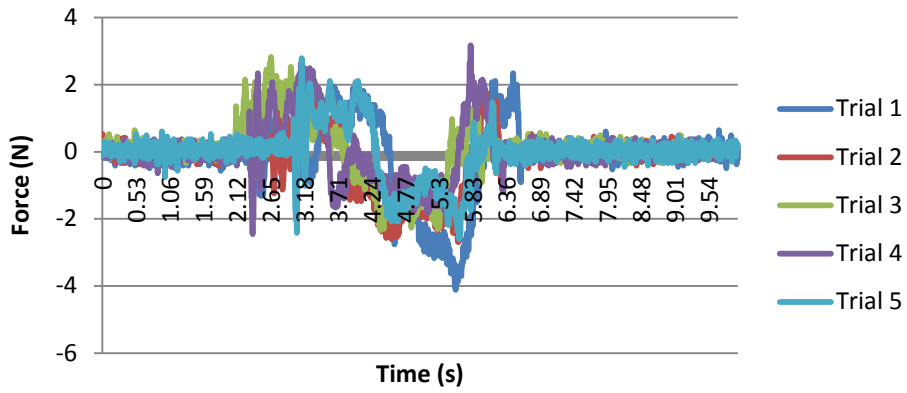

Fz for Ergonomic Handle: Horizontal Linear Incision

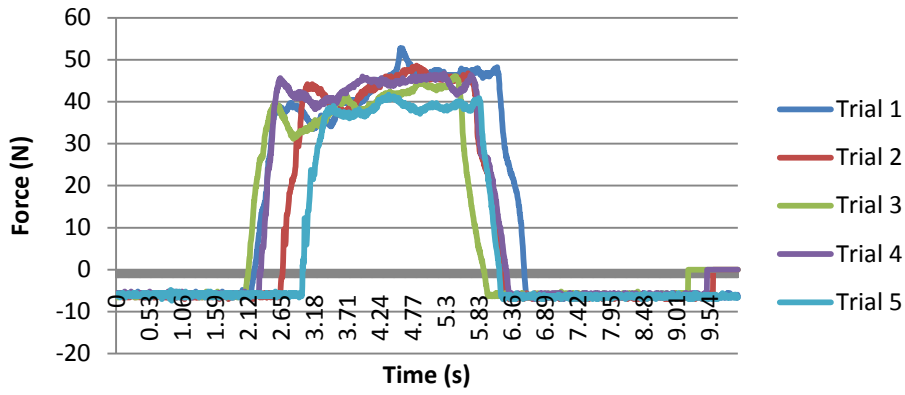

Mx for Ergonomic Handle: Horizontal Linear Incision

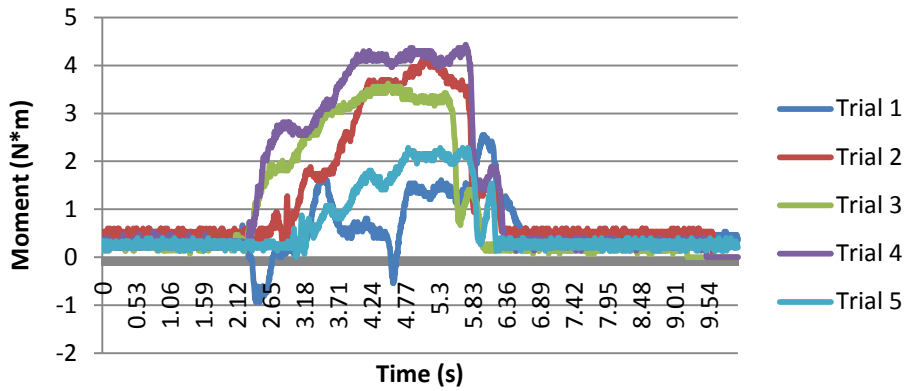

My for Ergonomic Handle: Horizontal Linear Incision

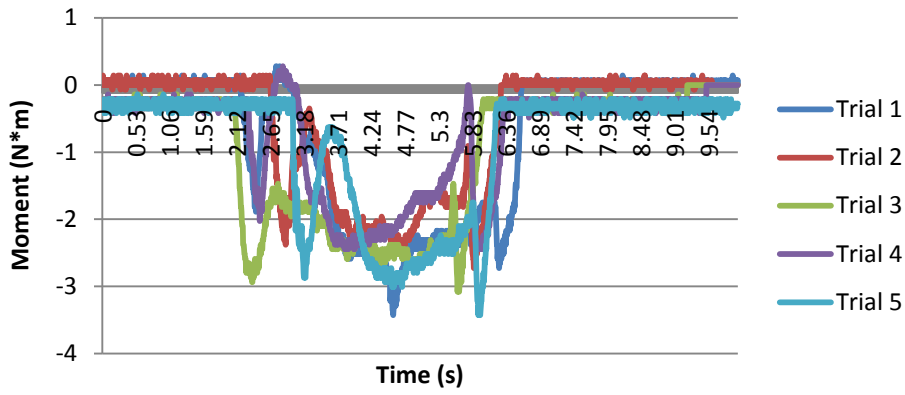

Mz for Ergonomic Handle: Horizontal Linear Incision

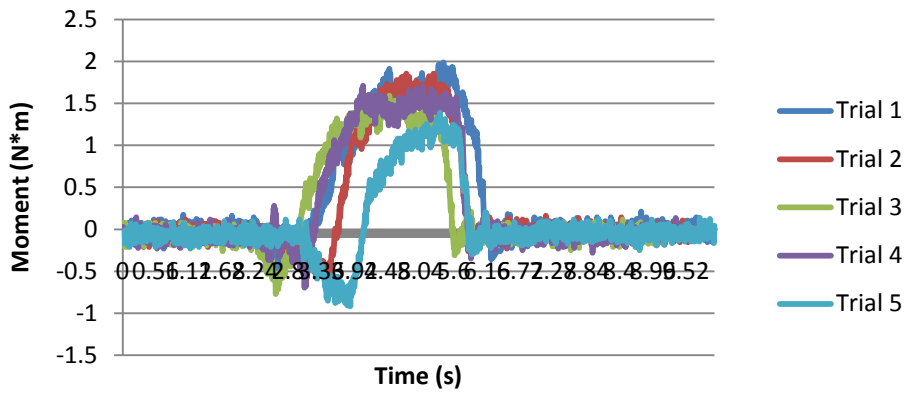

Average Fy for Ergonomic Handle: Horizontal Linear Incision

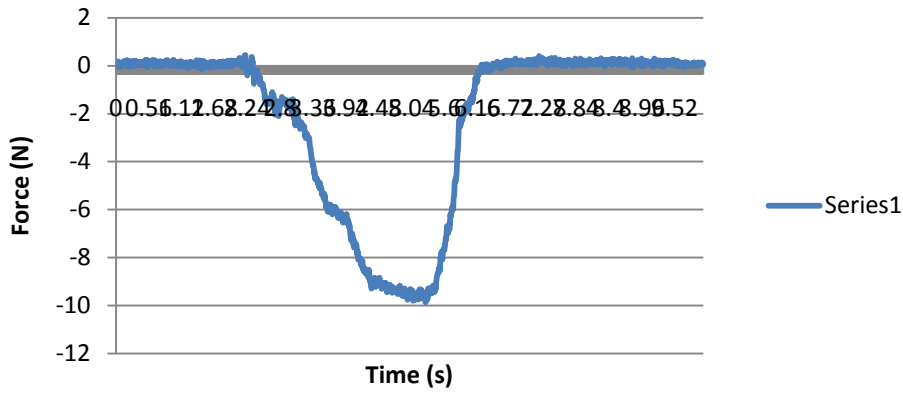

Average Fz for Ergonomic Handle: Horizontal Linear Incision

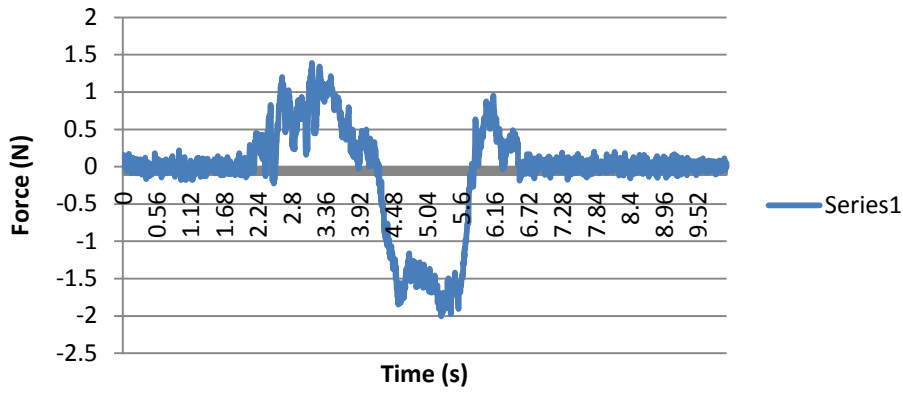

Average Fz for Ergonomic Handle: Horizontal Linear Incision

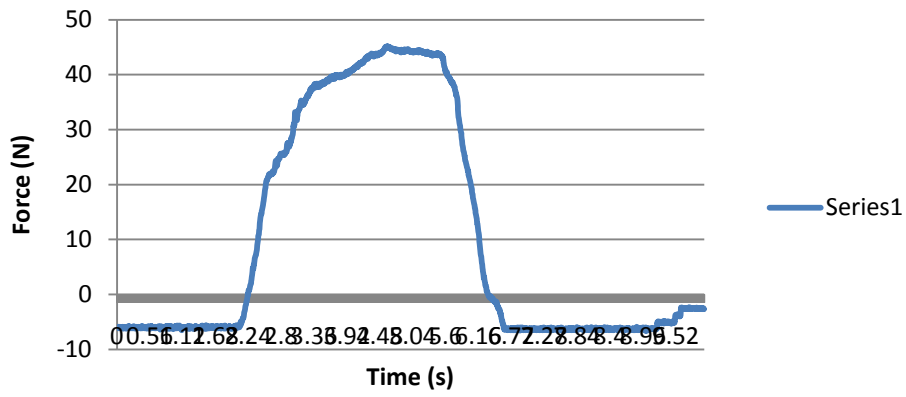

Average Mx for Ergonomic Handle: Horizontal Linear Incision

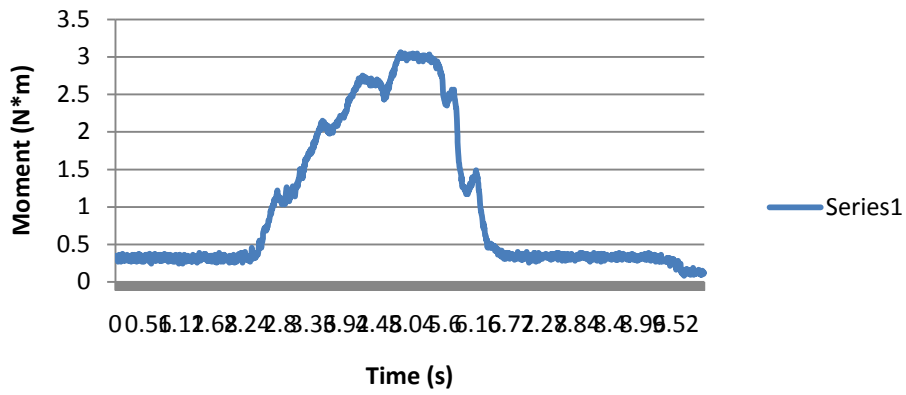

Average My for Ergonomic Handle: Horizontal Linear Incision

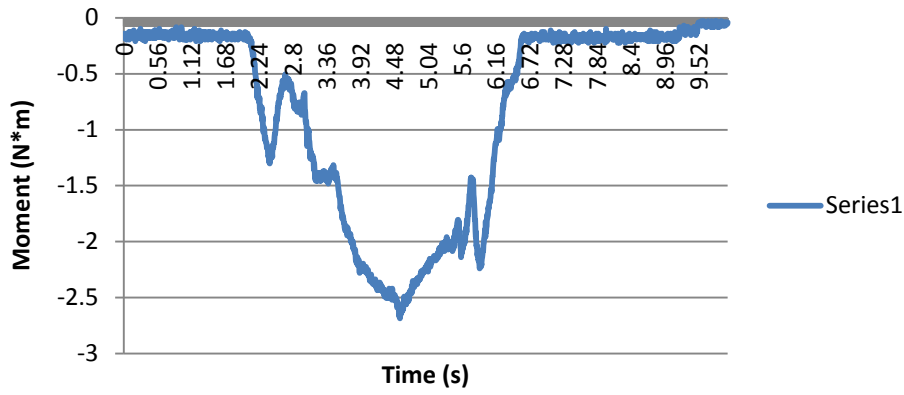

Average Mz for Ergonomic Handle: Horizontal Linear Incision

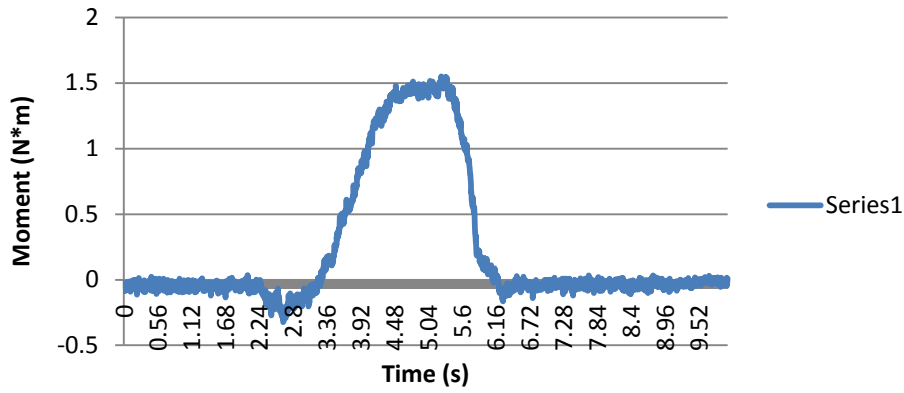

Fx for Ergonomic Handle: Vertical Linear Incision

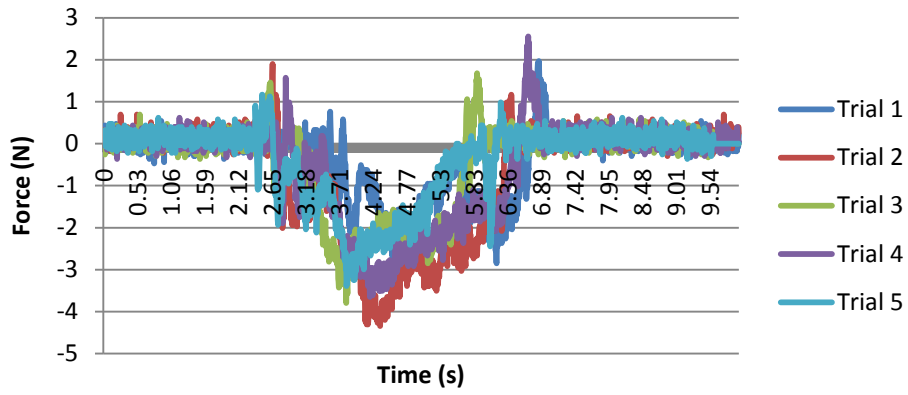

Fy for Ergonomic Handle: Vertical Linear Incision

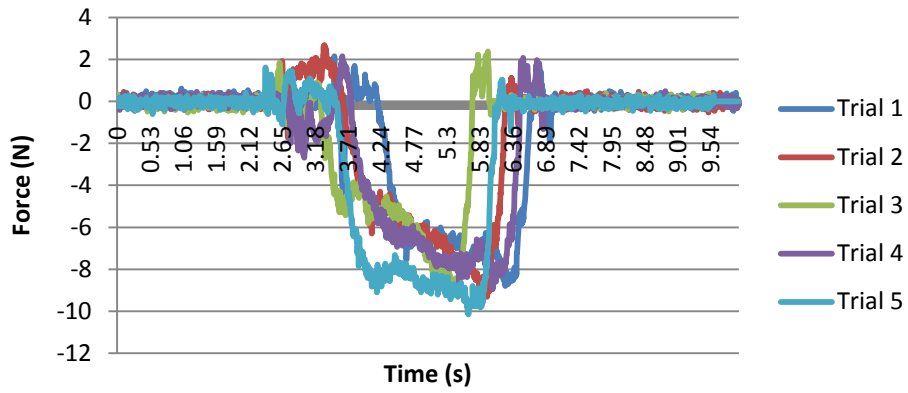

Fz for Ergonomic Handle: Vertical Linear Incision

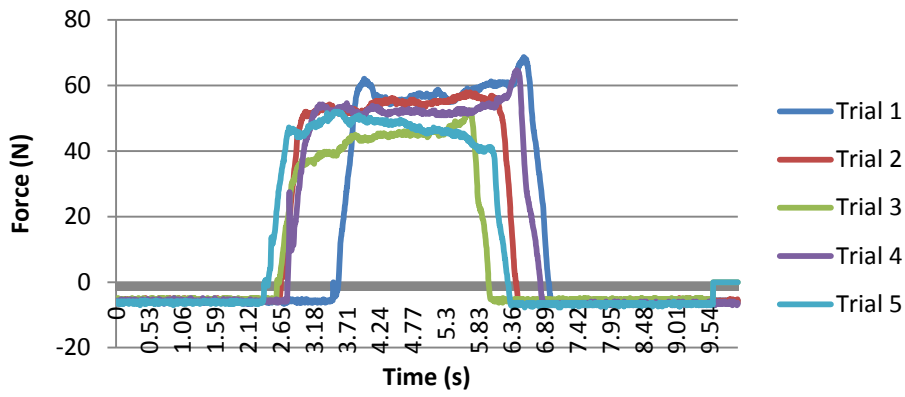

Mx for Ergonomic Handle: Vertical Linear Incision

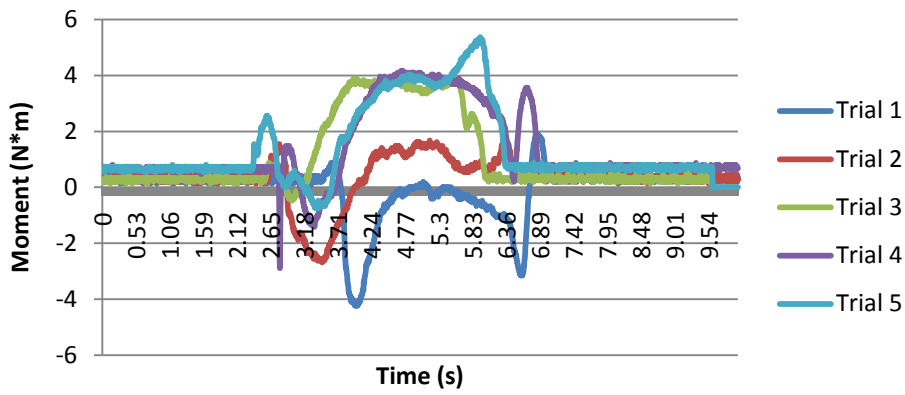

My for Ergonomic Handle: Vertical Linear Incision

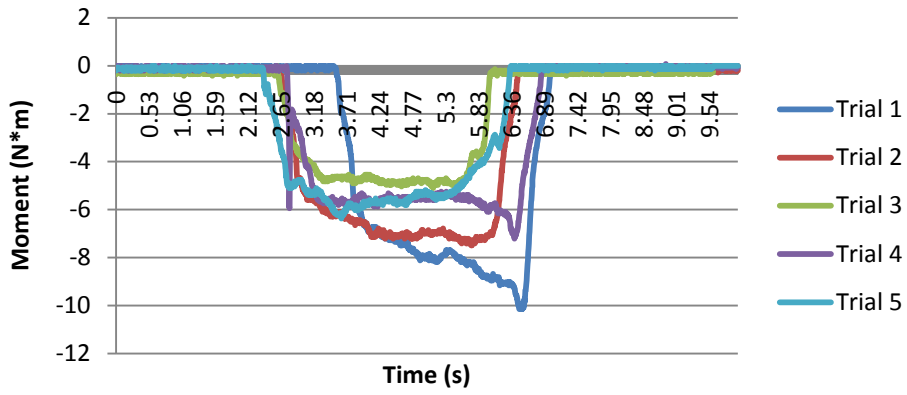

Mz for Ergonomic Handle: Vertical Linear Incision

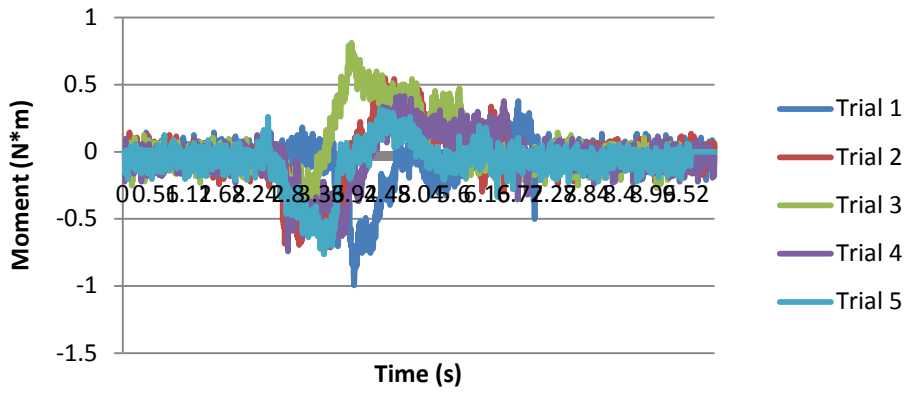

Average Fx for Ergonomic Handle: Vertical Linear Incision

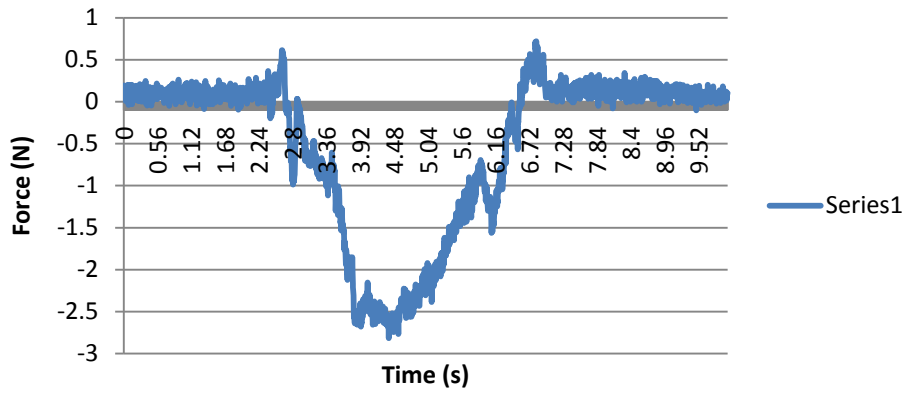

Average Fy for Ergonomic Handle: Vertical Linear Incision

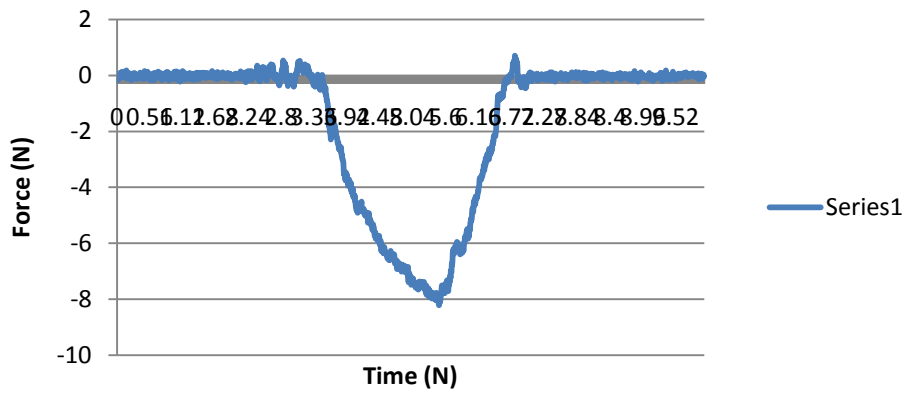

Average Fz for Ergonomic Handle: Vertical Linear Incision

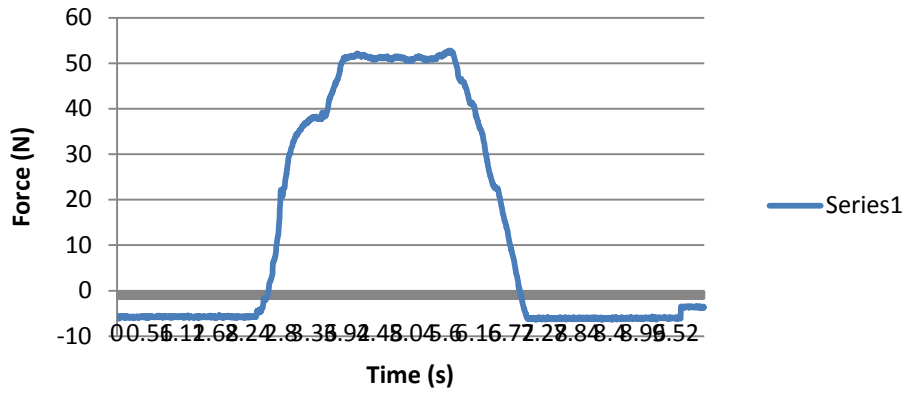

Average Mx for Ergonomic Handle: Horizontal Linear Incision

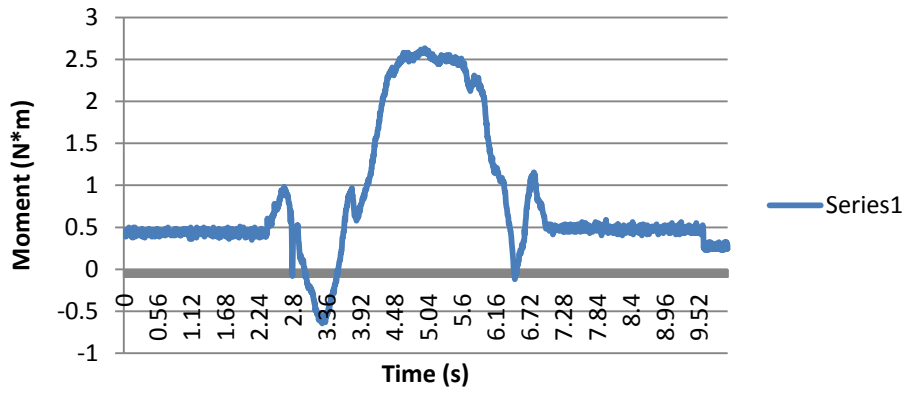

Average My for Ergonomic Handle: Vertical Linear Incision

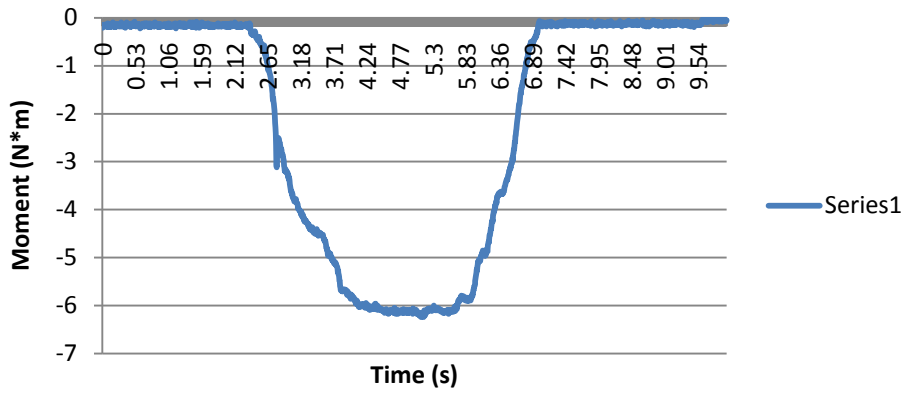

Average Mz for Ergonomic Handle: Vertical Linear Incision

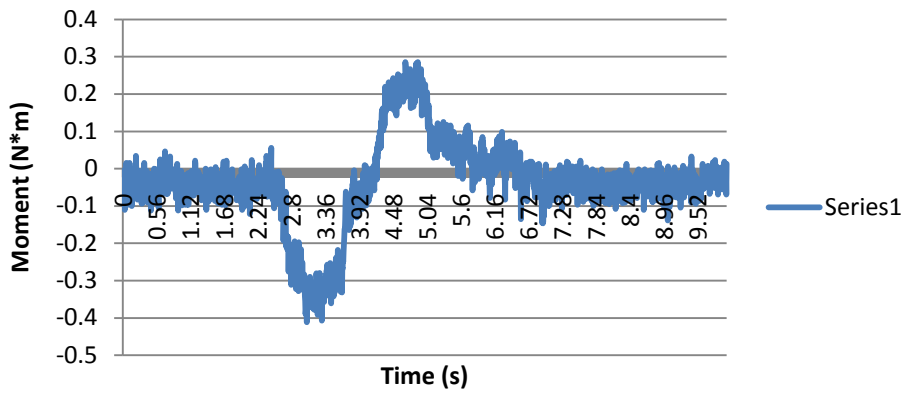

Appendix H: Surgeon Questionnaire

Name:

Ergonomic Scalpel Design Survey

Abstract: The goal of this project was to design, prototype, and test scalpel handles for small lesion removal. Scalpels are one of the most extensively used surgical tools in medicine today. However, the current flat-sided design limits the surgeons' ability to create precise, small incisions because the scalpel handle tends to rotate in their hands, especially for nonlinear incisions. To overcome this problem, we designed an ergonomic scalpel handle which features a cylindrical cross-section and smooth tapering that naturally fits hand positions which are used for creating an incision. Specifically, the scalpel handle was designed to increase the comfort, control, and precision a surgeon has during surgery.

Objective: The purpose of this survey is to determine which scalpel handle his preferred by surgeons.

Terms:

- *Comfort:* qualitative assessment of how the scalpel handle feels in the user's hand. Comfort derives from the hand positioning in relation to the design of the scalpel handle. Scalpel handle and blade length, diameter of grip, cross-sectional design, and balance are factors that affect the user's comfort.
- *Control:* A description of how well the scalpel handle interfaces with the user's hand. A design that tends to turn or flop in the user's hand during a particular incision will be a design that provides less control than one where the scalpel handle remains stationary in the user's grasp. Control is gained by a design that does not slip or rotate unexpectedly in the hand.
- *Precision:* Precision is generated from the surgeon's ability to stabilize their arms, shoulders, and torso, limiting unbalanced movements. Improving precision requires the scalpel handle to be designed such that it will not force the surgeon to move their body in an undesirable manner.

Prototype Survey		
Preferred Design # (#s: 1-x)		Rating 1-5 (1 Low or not preferred, 5 High or preferred)
Comfort	Length	
	Diameter of grip	
	Cross-sectional design	
	Balance	
	Comments	
Control	Rotational issues	
	Comments	
Precision	Body stability issues	
	Comments	

Appendix I: Table Relating Handle Dimensions to the Golden Ratio

Design Name	Grip Diameter	Grip Perimeter	#10 Blade Length	Blade Length/ Grip Circumference	% Error from Golden Ratio	#10 Blade Length (Sharpened Portion)	Sharpened Length/ Grip Circumference	% Error from Golden Ratio
	mm	mm	mm			mm		
Standard	N/A	28.00	38	1.36	-120%	27	0.96	-56%
VWR	N/A	60.60	38	0.63	-1%	27	0.45	28%
Large Handle	N/A	49.80	38	0.76	-23%	27	0.54	12%
Canica		34.00	38	1.12	-81%	27	0.79	-28%
ErgoCut		42.10	38	0.90	-46%	27	0.64	-4%
M2D2 Design	20.30	63.77	38	0.60	4%	27	0.42	31%
Alternative 1	20.00	62.83	38	0.60	2%	27	0.43	30%
Alternative 2	18.00	56.55	38	0.67	-9%	27	0.48	23%
Alternative 3	18.47	58.03	38	0.65	-6%	27	0.47	25%
Alternative 4	N/A	53.73	38	0.71	-14%	27	0.50	19%
Alternative 5	15.00	47.12	38	0.81	-30%	27	0.57	7%
Redesign 1.1	14.67	46.09	38	0.82	-33%	27	0.59	5%
Redesign 1.2	12.82	40.28	38	0.94	-53%	27	0.67	-8%
Redesign 1.3	14.67	46.09	38	0.82	-33%	27	0.59	5%
Redesign 1.4	14.67	46.09	38	0.82	-33%	27	0.59	5%
Redesign 2.1	13.85	43.51	38	0.87	-41%	27	0.62	0%
Redesign 2.2	14.85	46.65	38	0.81	-32%	27	0.58	6%
Redesign 2.3	15.85	49.79	38	0.76	-23%	27	0.54	12%
Final Design	10.85	34.09	38	1.11	-80%	27	0.79	-28%

Appendix J: Notes from Meeting with Client for Feedback on Designs

Commercial Alternatives (date)

- Standard Scalpel
 - Flat narrow, rectangular
 - Grooves near tip are supposed to prevent slipping
 - Limited effectiveness
 - Rotating the blade involves moving the whole hand
 - Rectangular handle cannot roll in the fingers
 - Back end does not naturally fit in the hand
 - Rotating the blade to a certain point causes it to flop to a 90 degree angle
 - Some blade angles require shoulder and arm movement
 - Even ineffective for straight incisions
 - Little fine control
 - Uncomfortable pinching required for grip
 - Difficult to remain straight and not drift off of the line
 - Blade is not naturally perpendicular to the skin
 - Perpendicular cuts are always symmetric, giving clean wound closure that is difficult to achieve with oblique cuts
- Ergocut Scalpel
 - Slippery surface, no tactile stability
 - No etching or roughness, although not polished smooth either
 - “Thumb rest”
 - Intended to lock the blade in place
 - Tendency to rest thumb there, but it moves
 - If it were intended as a thumb rest, it could keep the hand from sliding down into the blade area
 - Diameter too small
 - Fingers easily slip into the blade area
 - Natural gripping location is closer to the blade than intended by the design
- Large Handle Scalpel
 - Not round, so still limited to 90 degree turns
 - No texturing at all
 - The hand easily slips into the blade area
- VWR Scalpel
 - Plastic molded over the standard scalpel
 - Taper near the blade ends abruptly
 - Grip surface is lightly textured, but ineffective
 - Fails to create a resting spot for the webspace of the hand
- Desired handle features

- Rotation & digital manipulation
- Back of handle rests in the thumb webspace
 - Trough near the back of the design
- Gripping surface to minimize slipping
- Thumb rest

M2D2 Design and Alternatives 1-5 (date)

- Overall:
 - The finger side & thumb side may need to be different
 - Tactile effect near tip
 - the fingers slip as these are used
 - Alternative 2
 - flat surface is a no-go
 - don't ignore aesthetics
 - balance
 - Alternative 4
 - nice tapering at the tip
 - feels like good control at the tip end
 - Alternative 1
 - What are the aesthetics of the thickness?
 - May need a trough along the underside for the webspace
 - The radius at the tip is too abrupt, The radius of Alternative 4 is preferred
 - M2D2
 - Better
 - Grip surface is too far back
 - Best backside thus far
 - Alternative 3
 - Body isn't bad
 - The flare out for the palm is better than on the M2D2
 - The proximity toward the tip is closer, and gives better control
 - Better contact around fingers & thumb
 - The tail end is better on the M2D2
 - The lack of actual trough at the back end is a detriment
 - The trough helps position the scalpel in the hand
 - The flare out at the tip is good, but aesthetically it would be better if rounded slightly
 - No opinion about the nonagonal cross-section until a better gripping surface is on it
 - The balance is front-heavy
 - The M2D2 has more weight in the back, giving it a better feel

- Alternative 5
 - Seems like a cheap version of Alternative 4
 - The flattened area does nothing
- Desired traits of next prototype:
 - Tip of Alternative 4
 - good tapering from grip area to blade attachment
 - Diameter somewhere between Alternative 4 and M2D2
 - Grip area of Alternative 3
 - Distance & Curvature from tip to flare out along palm
 - Tail of M2D2
 - Thickness
 - Bulb at end
 - Finger trough oblique not horizontal
 - further back for the thumb than for the index finger
 - Hopefully, the new handle will reduce the need of the surgeon to move around the patient for different cuts
- Testing with new Handles
 - Some force tests were performed by Dr. Dunn with Alternative 3 and the M2D2 design
 - The blades were a bit wobbly, but Dr. Dunn repeatedly declared that the handles were "so much better" than the scalpels used at UMass
 - "They are better than the standard issue, right out of the gate. As far as I'm concerned."

Redesign 1.1-1.4 (date)

- Redesign 1.1
 - Distance between troughs needs to be extended
- Redesign 1.2
 - The thickness of 1 is better
- Redesign 1.3
 - Way too short
- Redesign 1.4
 - The shorter back trough is good, but the trough-trough difference needs to be ~1 cm longer
 - The back end is a bit light
 - Lengthening the handle may fix this
 - The back end beyond the trough could be rounded out to add more material
- Overall Impressions
 - Dr. Dunn wants to grip closer to the blade
 - look into integrating the half-circular blade attachment support into the handle
 - The whole design should be heavier
 - Shape is almost there, so the focus needs to shift to weight & balance

- Circular Cross-Section
 - more slippery than the nonagonal
 - The lack of appropriate surface is a factor
 - Circular can be knurled, but nonagonal may be cheaper if it doesn't need to be knurled
 - With knurling, the round is probably preferable to the nonagonal
 - Which cross-section is easier to manufacture? Circular or nonagonal?
 - at least have a good idea of this
- Dr. Dunn would like us to run tests with residents to get more feedback/data on our design
 - Subjects who are less biased than Dr. Dunn
 - How is this done in industry?
 - Companies will regularly run focus groups at UMass
 - How are these results used?
- Force Plate Data Collection
 - Dr. Dunn tries Redesign 1.4a first, then Redesign 1.4b
 - Dr. Dunn wants #15 blades to get a bit closer to the blade point while making the cuts
 - A #15 blade is used for shorter cuts while a #10 is used for longer cuts