



# Energy Analysis of Butanol Extraction Using Supercritical Carbon Dioxide

A Major Qualifying Project Report  
Submitted to the faculty of  
WORCESTER POLYTECHNIC INSTITUTE  
In partial fulfillment of the requirements for the  
Degree of Bachelor of Science

Submitted to:  
Michael Timko

By:  
Rachel Cody  
Vincent Sabo  
Halsey Vandenberg

April 28, 2016

## Abstract

This project documents the energy analysis of a butanol extraction process using supercritical carbon dioxide. Production of butanol as a biofuel has gained popularity in recent years but is limited by operating conditions of bacteria used for production and current extraction technologies. The project utilizes butanol production by *B. megaterium* and a continuous, in-situ supercritical carbon dioxide extraction and separation process as a method of reducing overall energy usage. Through energy analysis, the production and extraction process proved to be more efficient than other current methods.

Recommendations include process optimization and construction of a pilot model. These findings serve as support for increased research and commercialization of this extraction method.

## Acknowledgements

The team gratefully acknowledges Professor Michael Timko for his continual guidance and feedback, Professor Bernardo Castro-Dominguez for assistance with AspenPlus® modeling, and Professor Sergio Peres for assistance with preliminary calculations and assumptions.

# Table of Contents

Abstract .....	2
Acknowledgements .....	3
Introduction .....	6
Literature Review .....	9
Relevance of Butanol Production .....	9
Reaction Kinetics and Theory .....	10
Current Extraction Methods .....	11
Process Design .....	12
Supercritical Carbon Dioxide Extraction .....	13
Methodology .....	14
Process Diagram .....	14
A) Initial Solvent to Feedstock Ratio .....	14
B) Fermentation Substitution for Butanol in Feed .....	15
C) Mutual Solubilities of Carbon Dioxide and Water .....	15
D) Carbon Dioxide Separation in Turbine .....	16
Recycle Stream Temperatures .....	16
Distillation Column .....	17
Compressor Staging and Available Carbon Dioxide .....	17
AspenPlus Simulations for Energy Analysis .....	17
Results and Discussion .....	20
Energy Analysis .....	20
Initial Feed Ratio and Fermentation Assumption .....	21
Mutual Solubility Assumption .....	21
Turbine Separation Assumption .....	22
Conclusion and Recommendations .....	23
References .....	24
Appendix A – Calculations .....	26
Butanol Fermentation in Reactor .....	26
Mutual Solubilities of Carbon Dioxide and Water .....	27
Recycle Stream Temperatures .....	28
Energy Balance Calculations .....	29
Appendix B – Energy Requirements for Varying Situations .....	31
Appendix C – Aspen Process Diagrams .....	34
Appendix D – Aspen Input File .....	35
Aspen Input File for 1 bar, 25°C Carbon Dioxide Feed Scenario .....	35
Aspen Input File for 100 bar, 25°C Carbon Dioxide Feed Scenario .....	39
Aspen Input File for 100 bar, 40°C Carbon Dioxide Feed Scenario .....	42

## Table of Figures

Figure 1: Metabolic Pathway of ABE Fermentation by Clostridium Strains (Ranjan & Moholkar, 2012)	10
Figure 2: Process Diagram Using 1 bar, 25 °C Supercritical Carbon Dioxide	14
Figure 3: Solubility of Carbon Dioxide in Water Phase (King, 1992)	16
Figure 4: Solubility of Water in Carbon Dioxide Phase (King, 1992)	16
Figure 5: Distillation Column Sensitivity Analysis	18
Figure 6: Aspen Process Diagram for 1 Bar, 25 °C Carbon Dioxide Feed	34
Figure 7: Aspen Process Diagram for 100 Bar, 25 °C and 100 Bar, 40 °C Carbon Dioxide Feed	34

## Table of Tables

Table 1: Comparison of Liquid Fuels	9
Table 2: Fermentation Production Rates	15
Table 3: Energy Requirement of Units: Initial 1 bar, 25 °C Carbon Dioxide Feed Stream	18
Table 4: Energy Requirements of Different Extraction Methods (A. Oudshoorn, 2012; Qureshi, Hughes, Maddox, & Cotta, 2005).	20
Table 5: Energy Requirements of Different Feed Condition	21
Table 6: Energy Requirements of Heat Exchanger Units: Initial 1 bar, 25 °C Carbon Dioxide Feed System	31
Table 7: Energy Requirements of Units: Initial 100 bar, 25 °C Carbon Dioxide Feed System	31
Table 8: Energy Requirements of Heat Exchanger Units: Initial 100 bar, 25 °C Carbon Dioxide Feed System	32
Table 9: Energy Requirements of Units: Initial 100 bar, 40 °C Carbon Dioxide Feed System	32
Table 10: Energy Requirements of Heat Exchanger Units: Initial 100 bar, 40 °C Carbon Dioxide Feed System	33

## Introduction

Climate change has recently become a major global issue for energy production and risen to the forefront as motivation for renewable energy research and development. President Barack Obama has stated that “climate change is a massive problem... a generational problem. It's a problem that by definition is just about the hardest thing for a political system to absorb” (Peralta, 2015). After years of denying humanity’s contribution to globally rising temperatures, Vladimir Putin, President of Russia, recently declared “climate change has become one of the gravest changes humanity has ever faced” (The New York Times, 2015). Elon Musk, Founder of Tesla and SpaceX, related the current Syrian refugee crisis to future climate change refugee crises by stating “today, the challenge is in terms of millions of people, but in the future, based on what the scientific consensus is, the problem will be in the hundreds of millions and much more severe”. Geopolitics and big business aside, 97% of climate scientists agree global warming is caused by human activities involving the release of greenhouse gases into the atmosphere (Tenenbaum & Shaftel, 2015). Fossil fuel extraction for energy production, livestock production and industrialization, and mass deforestation efforts have all severely exacerbated the effects of climate change, and it is becoming an increasing problem for the world population to continue these habits. Human nature makes it difficult to want to change the simplest aspects of everyday life, but advancements in renewable energy technology and sustainable practices make combating climate change possible.

With the recent shift towards renewable energy resources, the ability of biofuel production to incorporate waste as a feedstock makes biofuel an attractive resource. Although biobutanol was not originally accepted as a promising fuel source, applications of biobutanol in the chemical industry were implemented several decades prior to petrochemical and fossil fuel commercialization. Biobutanol applications first became viable for large scale production in 1912 with Charles Weizmann’s patent of acetone-butanol-ethanol (ABE) fermentation using *Clostridium acetobutylicum* (Weizmann, 1919). ABE fermentation was widely used during World War I to make acetone for ammunition and during World War II to make lacquer for automobile coatings. After World War II, ABE fermentation declined drastically due to advancements in petrochemical technology (Zverlov, Berezina, Velikodvorskaya, & Schwarz, 2006). However, between 2000 and 2014, ethanol production in the United States increased from 1.6 billion gallons to 14 billion gallons per year (Energy Information Administration, 2015).

Although ethanol is currently one of the largest biofuel markets in the United States, Amrita Ranjan has identified several physical advantages that butanol has over ethanol as a fuel in her 2014 thesis. One of the major advantages is that “it can be blended well to any ratio of gasoline as well as diesel directly in the refinery,” making it more effective in combustion engines than ethanol-gasoline

mixtures (Ranjan & Moholkar, 2012). Another important aspect Ranjan explains is that “the air to fuel ratio for butanol is close to that of gasoline,” making for a simple adaptation of combustion engines for the use of butanol (Ranjan & Moholkar, 2012). Butanol also has higher energy content than ethanol and is therefore more worthwhile to the consumer and producer.

A National Geographic article showcases a modern, second-generation ABE fermentation process at a whiskey distillery, the Tullibardine, in Scotland. The article explains that only 10 percent of the outlet stream of the final product is marketable whiskey (Grose, 2001). The other 90 percent is a combination of draff (barley grain residue) and pot ale (fermented grain residue). This waste is often very hard to dispose of and is abundant in a region of the world where whiskey is widely produced. A company by the name of Celtic Renewables is working with Tullibardine to help reduce the amount of waste that the whiskey industry produces by fermenting their biomass waste stream to produce biobutanol. Taking advantage of this industry’s waste, Martin Tangney, founder and CEO of Celtic Renewables believes he can create a \$90 million biofuels industry (Grose, 2001).

While operational in industry, there are problems with current butanol fermentation processes. Products generated in ABE fermentation can limit the continuing process after certain concentration levels are reached within the system. The amount of solvent remaining in the system places limitations on the amount of glucose that can be utilized and present. To account for this, it would be necessary for the solvents to be continuously removed (Ranjan & Moholkar, 2012). The process also generates additional bacterial cultures, which can affect the subsequent compositions and yield of butanol. The formation of ABE butanol in the fermentation fluid can also limit the continual fermentation, subsequently creating a toxic environment. The toxicity causes “low productivity and low concentration of solvents in the fermentation broth and... limits the solvent yield”. A solution to these effects is the continual removal of ABE solvent from the fermentation fluid (Ranjan & Moholkar, 2012).

ABE separation requires optimization of energy and material costs as well as the purity of the separation. To maintain profit margins, it is not beneficial to utilize more energy than the profit of the butanol produced. There are currently several methods for ABE extraction in industry with the most energy-efficient methods being distillation, liquid-liquid extraction, gas stripping, and supercritical carbon dioxide extraction. The details of these methods and the typical equipment involved with each of these extraction processes will be explained in depth in the background section of this paper. Most current extraction technologies are applied to batch processes, but an ideal design would allow for continuous operation.

This project will address the proposal of continuous, in situ butanol extraction from a glucose feedstock using supercritical carbon dioxide and *B. megaterium*, a new bacteria strain being explored at Massachusetts Institute of Technology (MIT).



## Literature Review

### Relevance of Butanol Production

Today, the majority of fuel is derived from non-renewable resources, such as petroleum oil and coal. With the current high depletion rate of fossil fuels and greenhouse gas emissions, efforts are shifting to renewable energies. While renewables sources such as solar and wind successfully produce energy, the majority of fuels for chemical production and transportation are carbon based (A. Oudshoorn, 2012). For these demands, biofuel is a highly relevant alternative. Biofuel is carbon based, carbon neutral, and can be blended with petroleum fuels up to 20% to be compatible with existing technologies.

Biodiesel, ethanol and butanol are common biofuels, but butanol shows several advantages over the rest. Ethanol offers low energy content, limiting the blending capacities of the fuel. Ethanol is also prone to separation from gasoline when in the presence of water, posing operation problems. Butanol offers energy content comparable to biodiesel, and does not separate from gasoline in the presence of water. As observed in Table 1 below, similar properties of butanol and gasoline allow butanol blends in any ratio with gasoline or diesel. The biofuel is less corrosive to pipes due to the low vapor pressure of butanol, making transport of the fuel easy. With existing technologies, butanol can be blended with gasoline up to 20%. Following improvements to air: fuel ratios, higher blend ratios can be expected (Ranjan & Moholkar, 2012). Butanol is also able to be blended with biodiesels, due to the compounds low polarity (A. Oudshoorn, 2012). The heat of vaporization for butanol is higher than that for gasoline, lowering risk for “cold start” problems with existing technologies (Ranjan & Moholkar, 2012).

**TABLE 1: COMPARISON OF Liquid Fuels (RANJAN & MOHOLKAR, 2012)**

Fuel	Energy Density (MJ L <sup>-1</sup> )	Air: Fuel Ratio	Heat of Vaporization (MJ/kg)	Research octane number	Motor octane number	Cetane number
<b>Gasoline</b>	32	14.6	0.36	91-99	81-89	-
<b>Butanol</b>	29.2	11.2	0.43	96	78	-
<b>Ethanol</b>	19.6	9.0	0.92	129	102	54
<b>Methanol</b>	16	6.5	1.2	136	104	
<b>Biodiesel</b>	31-33	12.5	-	-	-	48-65

## Reaction Kinetics and Theory

In addition to these advantages, biobutanol is biodegradable and can be produced from renewable resources such as biological substrates and bacteria strains. The most common strains utilized are Clostridium. The optimum temperature for butanol clostridium strains is between 30-40 °C. In butanol production, there are two major phases of fermentation: acidogenesis and solventogenesis. The metabolic pathway for clostridial cultures detailing these phases can be followed below in Figure 1.

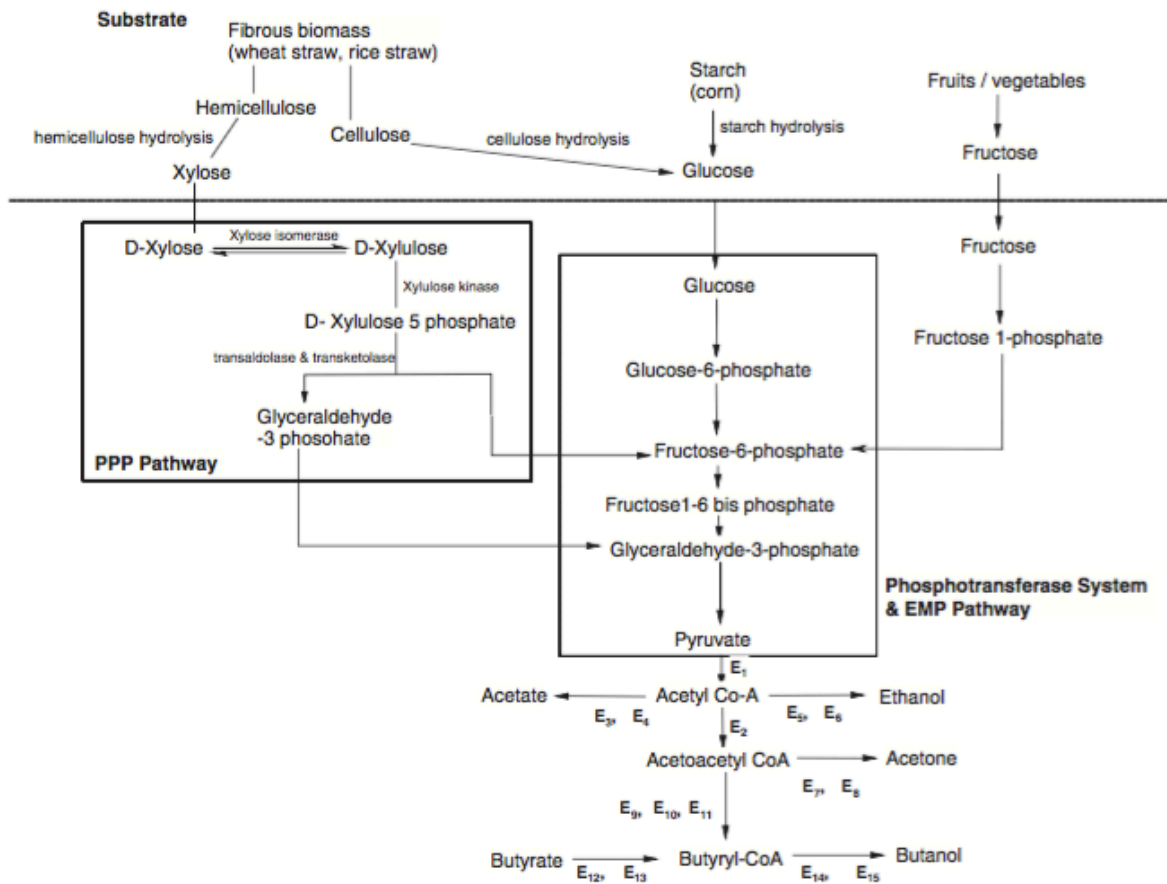

**FIGURE 1: METABOLIC PATHWAY OF ABE FERMENTATION BY CLOSTRIDIUM STRAINS (RANJAN & MOHOLKAR, 2012)**

During acidogenesis, acid is produced and the initial pH of the broth drops from 6.8-7 to 4.5-5 due to the secretion of acetate and butyrate by the growing cells. Sugars from the substrates are metabolized via the Embden-Meyerhof pathway (EMP) or Pentose Phosphate Pathway (PPP) depending on the chemical structure of the sugar. Pyruvate is produced from glucose through glycolysis, and the PPP produces carbon dioxide. The produced glycolysis is broken down to produce carbon dioxide and acetyl-CoA. Butyryl-CoA is also produced. Acetyl-CoA and butyryl-CoA are later converted to acetate and

butyrate respectively by enzymes. This causes a drop in pH. Following this drop in pH, the cells respond and switch to the solvent producing phase. During this phase, the products are re-incorporated and converted to acetone and butanol by the enzyme Co-A transferase (Ranjan & Moholkar, 2012).

## Current Extraction Methods

Today, there are several separation techniques to separate butanol from the fermentation broth. This report will review five methods in particular: distillation, ternary extraction, gas stripping, and supercritical extraction.

Distillation is the most traditional method of separation in industry (Arjan Oudshoorn, Van Der Wielen, & Straathof, 2009). Distillation utilizes differences in boiling point and vapor pressure of the various substances. In the case of butanol separation from the fermentation broth, water is the light key in the system. Therefore, the majority of energy utilized by the process will be caused by the evaporation of water in the broth. A binary azeotrope exists at 92.7 °C, but can be broken by introducing a third component to the mixture or adjusting the column pressure (A. Oudshoorn, 2012). These adjustments will increase performance, and additionally the energy consumption of the column. Scale will also affect the energy consumption, and in turn, associated costs. In all cases, “pure butanol can be obtained at the cost of energy and investment in equipment” (Arjan Oudshoorn et al., 2009).

Ternary extraction utilizes the introduction of a third component to aid in phase separation. In the case of butanol and water, butanol remains soluble in water upon reaching the maximum concentration of 20 g/L tolerated by the cell cultures. Through the addition of salts, a phase split can be caused by the reduced solubility of butanol in water. However, entry of the salts into the fermenter also results in salt concentrations too high for fermentation to occur. This disrupts the fermentation process for most *Clostridium* strains, and therefore this process is still being researched (Arjan Oudshoorn et al., 2009).

Gas stripping utilizes an oxygen-free gas to sparge the fermentation broth of butanol. This process can occur in the reactor or in a separate vessel (Arjan Oudshoorn et al., 2009). Oxygen-free gas, generally nitrogen, is utilized to preserve the anaerobic conditions required for fermentation, and can be recycled within the system after separating it from the butanol (Ranjan & Moholkar, 2012). Low risk of fouling both equipment and the fermentation broth allows gas stripping can be used in batch, fed-batch, and continuous processes (Arjan Oudshoorn et al., 2009). Advantages of utilizing gas stripping include simplicity of process, clean product removal, and the ability to use gases generated through fermentation to strip the broth. Additionally, the removal rate of butanol can be increased by improving the gas-to-liquid contact in the broth. Packing and countercurrent contact can increase contact area and improve this rate (Ranjan & Moholkar, 2012).

General extraction methods rely on partition coefficients of butanol and water, and the solubility of butanol in water. Introduction of a highly nonpolar solvent achieves this by negatively affecting the solubility of butanol in the solvent, increasing selectivity. This allows butanol to concentrate in the solvent with a higher boiling point for direct distillation, rather than distillation from the fermentation broth (Arjan Oudshoorn et al., 2009). Carbon dioxide meets these criteria, and poses minimal risks with use due to its nontoxic and nonflammable nature. Carbon dioxide is also a low cost solvent (Laitinen & Kaunisto, 1999a). Supercritical extraction utilizes reduced pressure to easily remove the supercritical fluid from the extracted organic material (Khosravi-Darani & Vasheghani-Farahani, 2005; Arjan Oudshoorn et al., 2009). As with general extraction, supercritical carbon dioxide is frequently selected as the supercritical fluid. This is due to its “critical temperature (31.3°C) and pressure (7.3 MPa)” which aid in extracting volatile components (Khosravi-Darani & Vasheghani-Farahani, 2005). Supercritical carbon dioxide also causes minimal fouling, resulting in minimum wear on process equipment. Processing carbon dioxide into a supercritical fluid develops a density similar to liquids, and shifts viscosity to a value between common gas and liquid values. Utilizing carbon dioxide under supercritical conditions is generally simpler and more cost effective than a traditional liquid-liquid extraction (Laitinen & Kaunisto, 1999a). Increasing surface contact between the supercritical carbon dioxide and fermentation broth can further improve the process and production yield (Güvenç, Mehmetoglu, & Calimli, 1998).

## Process Design

Within industry, there are three design methods for processing butanol: batch, fed-batch, and continuous. Batch fermentation is the simplest design, utilizing a mechanically stirred reactor. This reactor would include additional design aspects, such as gas spargers or temperature controlling jackets. Batch fermentation reactors begin with substrate and any additional nutrients in the reactor, and an automated process is started to control the reactor temperature. Oxygen-free nitrogen or carbon dioxide flows over the fermentation broth to maintain the anaerobic conditions necessary to cell growth. Upon reaching a solvent concentration of 20g/L, cell growth is inhibited and fermentation stops. Reaching this concentration usually takes 48-72 hours (Ranjan & Moholkar, 2012). Following the stop of fermentation, cells and solids are removed via centrifugation and the liquid is recovered in a process unit.

Fed-batch fermentation is utilized when the “substrate is toxic to microbial culture”. In fed-batch fermentation, the reactor is “initially in batch mode with low substrate concentration” (Ranjan & Moholkar, 2012). The broth fills approximately half of the reactor volume, and is continually added as the cells consume the substrate to maintain a solvent concentration below the toxic level. Assuming the solvent is not removed continuously, the process ceases when the volume occupies approximately 75% of

the reactor volume. With this process, the fermentation must be paired with a suitable solvent removal process to prevent reaching a solvent concentration toxic to the cell cultures.

With all process designs, production is greatly inhibited by the upper limit concentrations for the products, due to the negative affect the product has on the cell cultures. This problem can be limited by continuous removal of the product (A. Oudshoorn, 2012). Continuous fermentation is designed to improve reactor production, although a low concentration of product is generally produced compared to batch fermentation. The major difficulty that continuous fermentation poses is the fluctuating solvent level due to continuous removal. This design has been explored as both single stage, two-stage, or multistage systems. In particular, two-stage fermentation has been explored to separate the two phases of fermentation into separate vessels. Studies have shown that single-stage continuous fermentation had a production rate of 1.5 g/L-h at a solvent concentration of 15.9 g/L, and a production rate of 0.4 g/L-h at a solvent concentration of 12 g/L. Studies also showed a production rate of 0.55 g/L-h at a solvent concentration of 18.2 g/L, and a production rate of 2-3g/L-h at a solvent concentration of 12-15 g/L (Ranjan & Moholkar, 2012).

### **Supercritical Carbon Dioxide Extraction**

In this particular report, a continuous supercritical carbon dioxide extraction of butanol with *B. megaterium* will be designed. This particular bacterium is being explored by individuals at Massachusetts Institute of Technology (MIT) and is able to exclusively produce butanol under higher pressures than *Clostridium* bacteria strains. For theoretical design purposes, a system placing the *B. megaterium* culture under 100 bar was designed.

## Methodology

Our process is designed to reduce the amount of energy required to produce 1 kg of butanol compared to the currently practiced separation techniques as described in the Literature Review. The following subsections describe our methodology for process design. A supercritical (SC) carbon dioxide feed at 1 bar and 25°C is utilized for discussion of our methodology; figures and tables for the process using 1 bar and 40°C SC carbon dioxide and 100 bar and 40°C SC carbon dioxide can be found in Appendix B.

## Process Diagram

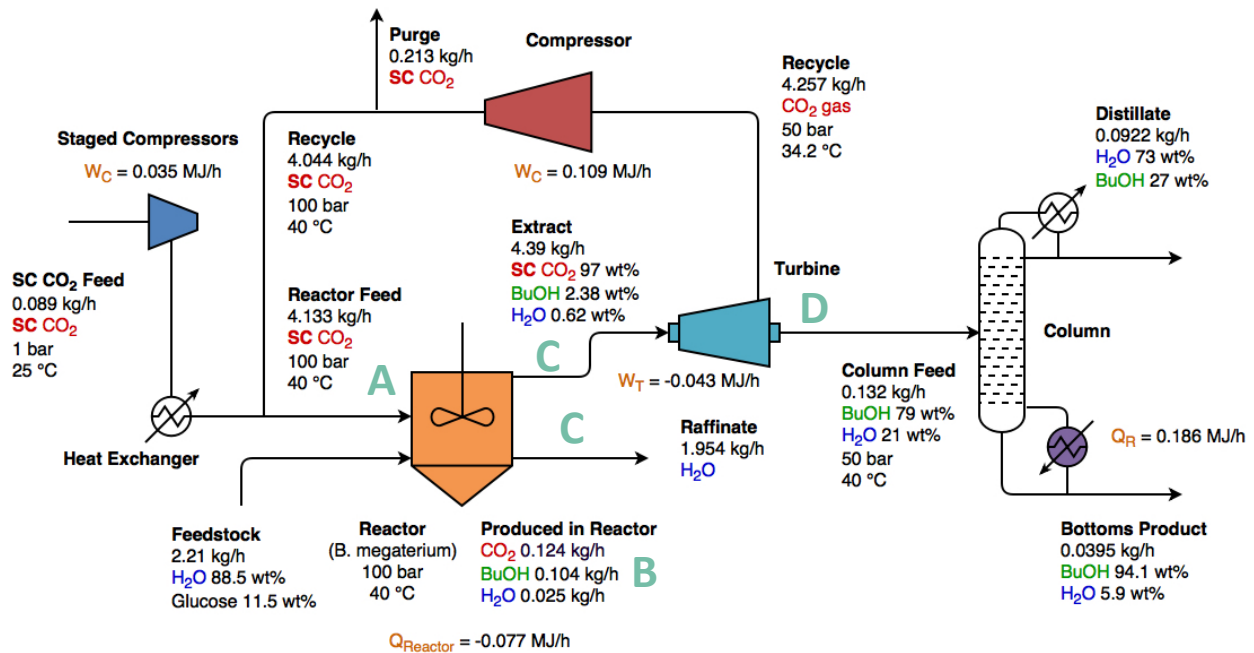

FIGURE 2: PROCESS DIAGRAM USING 1 BAR, 25 °C SUPERCRITICAL CARBON DIOXIDE

Our team designed the above butanol extraction process (Figure 2) using data from the literature as described in subsequent assumptions A-D and associated process unit design, as indicated on the above diagram.

### A) Initial Solvent to Feedstock Ratio

Within the reactor, the SC carbon dioxide solvent: feed ratio was set to 5.4 kg/h solvent: 2.08 kg/h feed at 40 °C and 100 bar (Laitinen & Kaunisto, 1999b). This ratio was selected based on work by Antero Laitinen, which determined that at 40 °C and 100 bar, the selected ratio resulted in the best butanol extraction out of the reactor, or 99.7% butanol in the extract (Laitinen & Kaunisto, 1999b). Based on the same work, the butanol entering the system in the feedstock was set as 5 wt% of the chosen feed flow of 2.08 kg/h, or 0.104 kg/h. The chosen reactor conditions aligned with optimum operating

temperatures and theoretical pressure limits for *B. megaterium*, ensuring butanol production by the bacteria.

## B) Fermentation Substitution for Butanol in Feed

### Fermentation Products

In our design, all butanol within the system is produced within the reactor by *B. megaterium* cultures. Complete conversion of glucose in the feedstock was assumed to produce 0.104 kg/h of butanol. Through stoichiometry, the amount of necessary glucose within the feedstock and production rates of carbon dioxide and water from fermentation were determined and shown below. Calculations can be found in Appendix A.

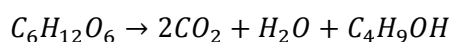

TABLE 2: FERMENTATION PRODUCTION RATES

Glucose (kg/h)	Carbon Dioxide (kg/h)	Water (kg/h)	Butanol (kg/h)
0.254	0.124	0.025	0.104

The SC carbon dioxide solvent flow rate into the reactor was adjusted from 5.4 kg/h to 5.276 kg/h to account for carbon dioxide produced by *B. megaterium*. Lastly, the 0.254 kg/h glucose flow rate necessary for complete conversion was added to the feedstock, resulting in a final feedstock flow rate of 2.21 kg/h.

### Heat of Fermentation

The heat of fermentation was determined to be -176.3 kJ/h, which would raise the temperature of the reactor to 44.5 °C. Calculations can be found in Appendix A. However, we decided to jacket the reactor for cooling water to keep the temperature to 40 °C, and reuse that heat elsewhere in the system.

## C) Mutual Solubilities of Carbon Dioxide and Water

Based on work by Antero Laitinen and the initial selected solvent: feed ratio, 99.7% of the butanol entering the system exits the reactor in the extract. To determine the amount of carbon dioxide and water also exiting the reactor in the extract, it was assumed that carbon dioxide and water were in equilibrium. Work conducted by M.B. King served as a basis for the mutual solubilities of carbon dioxide and water at 40 °C (King, 1992). For water in the carbon dioxide phase, the solubility was 4.28 mol water per 1000 mol carbon dioxide at 40 °C. For carbon dioxide in the water phase, the data only existed for temperature values less than or equal to 25 °C. Considering the solubility versus temperature relationship for carbon dioxide in the water phase is linear, as shown in Figures 3 and 4, it was extrapolated that the

solubility of carbon dioxide in the water phase would be 2.14 mol carbon dioxide per 100 mol water at 40°C.

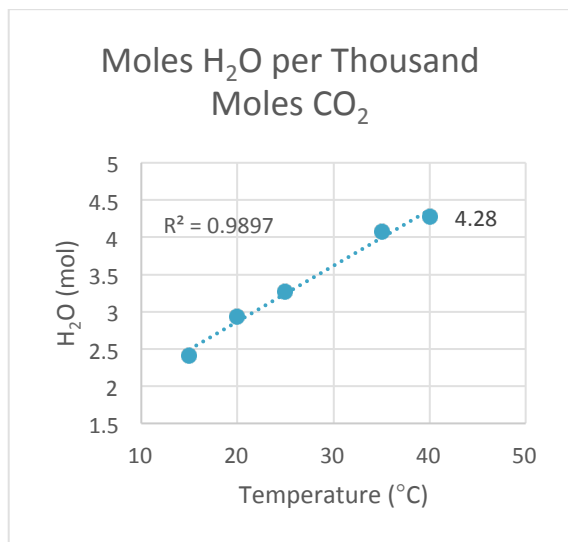

**FIGURE 3: SOLUBILITY OF CARBON DIOXIDE IN WATER PHASE (KING, 1992)**

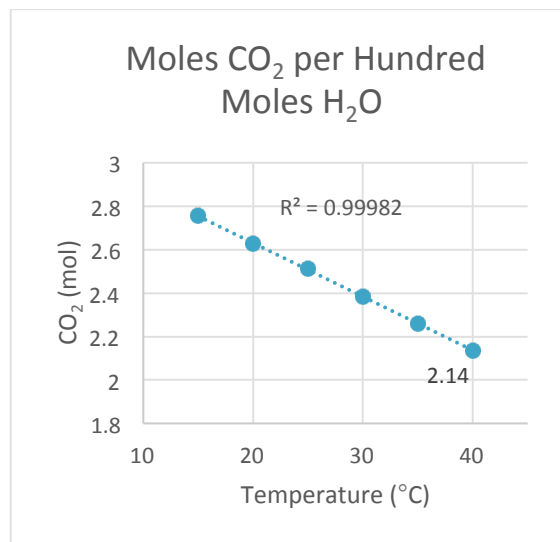

**FIGURE 4: SOLUBILITY OF WATER IN CARBON DIOXIDE PHASE (KING, 1992)**

Using this information, the amount of carbon dioxide and water exiting the reactor in the extract and raffinate streams were determined. These calculations are detailed in Appendix A.

## D) Carbon Dioxide Separation in Turbine

For the purposes of this project, it was assumed that all carbon dioxide entering the turbine exits as a pure carbon dioxide gas stream and all butanol and water exits the turbine in a separate feed stream to the distillation column. This assumption was based on the critical pressure of carbon dioxide of 73.8 bar and the reduction of pressure of carbon dioxide from 100 bar to 50 bar. Thus, it was assumed that all SC carbon dioxide undergoes a phase shift to a gas in the turbine, separating from the butanol and water by phase. The recycle stream and column feed flow rate calculations found in Appendix A were based on this assumption. The SC carbon dioxide feed flow rate was adjusted to account for the recycle stream and a standard 5% purge stream off the recycle stream was added to prevent accumulation of carbon dioxide within the system (Figure 2, and Appendices A and D).

## Recycle Stream Temperatures

The change in temperature of the carbon dioxide recycle stream due to non-isothermal turbine expansion and re-compression, as shown in Figure 1, was calculated. It was determined that the compressor is able to raise the temperature of the recycle stream from 34.2 °C to 39.97 °C, prior to the stream joining with the SC carbon dioxide feed stream and entering the reactor at 40 °C. Calculations are included in Appendix A.



Next, we calculated the change in temperature of the carbon dioxide recycle stream due to non-isothermal turbine expansion and re-compression, as shown in the process diagram (Figure 1). We determined that the compressor is able to bring the temperature of the recycle stream back up to 39.97 °C. Calculations are included in Appendix A.

### Distillation Column

Following the calculation of the flow rate and composition for the butanol-water column feed stream, AspenPlus® was used to create a preliminary distillation column model under the determined feed flow specifications. The final flow rate of bottoms product was 0.0375 kg/h and 98.5 wt% butanol.

### Compressor Staging and Available Carbon Dioxide

Two process designs were developed to conduct the overall energy analysis for scenarios with carbon dioxide available at different conditions – 1 bar and 25°C, 100 bar and 25°C, and 100 bar and 40°C. One process design, shown in Figure 2, includes four compressors and two heat exchangers to raise the pressure of the 1 bar and 25°C scenario to 100 bar. The compressor staging was required to maintain an outlet: inlet compression ratio below 4:1 and the outlet temperature of the carbon dioxide below 400 °F (Turton, Richard. et al). The second process design excludes the feed compressors and heat exchangers as the carbon dioxide for this process is available at 100 bar and 25°C or 100 bar and 40°C, depending on the scenario.

### AspenPlus Simulations for Energy Analysis

Following preliminary manual process design and calculations, the two process designs were modeled in AspenPlus®, under the specifications identified in the previous subsections. To determine the total energy cost per kilogram of butanol produced, an energy balance was conducted around the AspenPlus® system. The Lee-Kesler-Plocker equation of state was used for the process model. AspenPlus® process diagrams can be found in Appendix C. The input files for the process simulations are included in Appendix D.

A sensitivity analysis was conducted on the distillation column to determine the sensitivity of the butanol weight fraction with respect to the number of stages in the column. The AspenPlus® generated analysis can be found below in Figure 5. The analysis showed that beyond nine stages there was no increase in the purity of butanol exiting the column. Based on a 10% safety factor heuristic for the number of stages in the column, a ten stage column was utilized in AspenPlus® process design of both scenarios (Turton, Richard. et al).

### Distillation Column Sensitivity Analysis: Purity of Product With Respect to Number of Stages

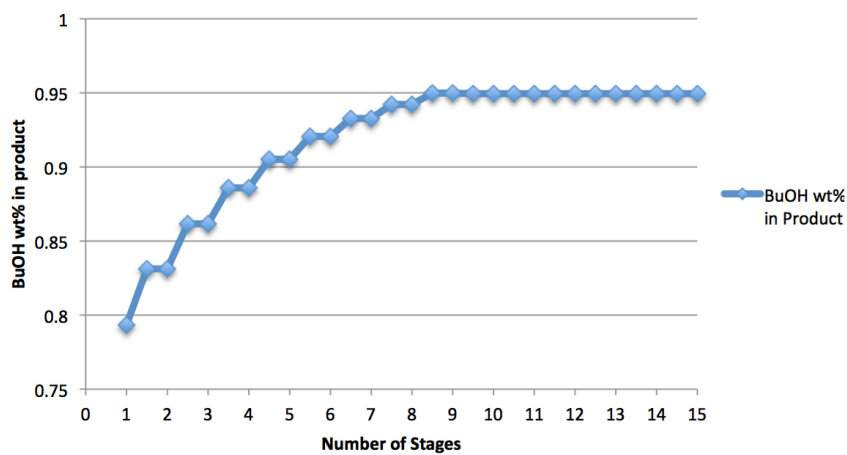

**FIGURE 5: DISTILLATION COLUMN SENSITIVITY ANALYSIS**

The following values for energy cost in MJ/h by unit in the AspenPlus® process are outlined in Table 3 below. The preliminary manual calculations for each unit are included in Appendix A. The heat of fermentation calculated was included in final energy requirement total. The energy gained through heat exchangers was treated as a heat sink and not included in the overall total for each scenario, as it could not be guaranteed that all energy could be collected. Design of a heat exchanger network to optimize energy within the system would serve to collect energy and minimize overall energy usage. Appendix B details the energy requirement for all scenarios, as well as the energy to potentially be gained through a heat exchanger network.

**TABLE 3: ENERGY REQUIREMENT OF UNITS: INITIAL 1 BAR, 25 °C CARBON DIOXIDE FEED STREAM**

Unit	Description	Energy Requirement (MJ/h)
<b>Staged Compressors</b>	Compress carbon dioxide at 1 bar and 25 °C to 100 bar and 25 °C	0.007
		0.005
		0.010
		0.012
<b>Heat of Fermentation</b>	Heat released during fermentation in reactor	- 0.176
<b>Reactor</b>	Work required to operate reactor	0.099
<b>Turbine (isentropic)</b>	Separation of SC carbon dioxide from butanol water by reducing pressure from 100 bar to 50 bar	- 0.043

<b>Recycle Compressor (isentropic)</b>	Recompress carbon dioxide from 50 bar to 100 bar	0.109
<b>Column Condenser</b>	Energy required to condense distillate water-butanol mixture	-0.055
<b>Column Reboiler</b>	Energy required to vaporize bottoms butanol-water mixture	0.185
	<b>Total:</b>	/ 0.0395 kg/h bottoms product (wt% butanol)
	<b>MJ/kg Product:</b>	<b>3.90</b>

In the following section, the determined energy requirements for this process and the other scenarios will be compared to other methods found in literature.

## Results and Discussion

### Energy Analysis

The goal of this project was to design a process to in situ continuous extraction of butanol using supercritical carbon dioxide. An additional goal was to determine if the process was more or less energy efficient than currently used extraction methods. Table 4 below compares the overall energy values from different methods needed to produce 1 kg of butanol. This table was partially excerpted from a 2012 thesis on butanol recovery written by Arjan Oudshoorn (A. Oudshoorn, 2012).

**TABLE 4: ENERGY REQUIREMENTS OF DIFFERENT EXTRACTION METHODS (A. OUDSHOORN, 2012; QURESHI, HUGHES, MADDOX, & COTTA, 2005)**

Method	Energy Requirement (MJ/kg butanol)
<b>Gas Stripping</b>	22
<b>Liquid-Liquid Extraction</b>	9
<b>Distillation</b>	24
<b>Supercritical CO<sub>2</sub> Extraction 1 bar, 25 °C</b>	3.9

The methods identified below in Table 4 are a few of the most commonly used extraction methods, as discussed in the Literature Review. Direct comparison to these methods shows that the design of this project using supercritical carbon dioxide is significantly more efficient than the other methods. This is possible by the ability of *B. megaterium* to selectively produce butanol under high pressure. Prior to the discovery of this bacteria strain, the in situ use of supercritical carbon dioxide was not possible because the bacteria could not survive when exposed to high pressures. Although the energy value shown in the table above assumes that carbon dioxide is available at 1 bar and 25°C, Table 5 below shows the energy required for the scenarios of readily available carbon dioxide at 100 bar.

Upon review, the only unit that would require more energy with lower pressure carbon dioxide available is the feed compressor. A strong advantage of this process is that, at steady state, the fermentation reaction can produce almost enough carbon dioxide to stay self-sufficient with little make-up carbon dioxide needed. As Table 5 shows, the overall energy needed to produce 1 kilogram of butanol does not change much with the feed conditions due to the small amount of carbon dioxide needed at steady state.

**TABLE 5: ENERGY REQUIREMENTS OF DIFFERENT FEED CONDITIONS**

Feed Pressure (bar)	Feed Temperature (°C)	Energy Requirement (MJ/kg butanol)
<b>1</b>	<b>25</b>	3.90
<b>100</b>	<b>25</b>	3.01
<b>100</b>	<b>40</b>	3.01

It is important to discuss the validity of assumptions made while conducting the material and energy balance in the process, and when modeling the process in AspenPlus®. The validity of these assumptions is discussed below in the order the assumptions were presented in the methodology.

### Initial Feed Ratio and Fermentation Assumption

The initial SC carbon dioxide solvent: feed ratio was made based on a paper by Antero Laitinen which claimed this ratio produced the highest concentration of butanol in the extract (Laitinen & Kaunisto, 1999b). The ratio refers to the amount of carbon dioxide entering the system and the amount of butanol entering in the feedstock. The process that Laitinen's work refers to only models the extraction in the vessel and not the fermentation reaction. Since the process being designed in this paper assumes fermentation occurs in the reactor vessel, the butanol in the feed was replaced with the amount of glucose needed to produce the same amount of butanol, assuming complete conversion. There are obvious validity issues with assuming complete conversion considering there is no available information on how the new strain of bacteria behaves under process conditions of this project. The behavior of the bacteria under varying process conditions should be explored further.

### Mutual Solubility Assumption

The solubility of water in supercritical carbon dioxide and supercritical carbon dioxide in water had to be determined for reactor exit conditions in both the extract stream and the raffinate, respectively. In both exiting streams, butanol was a third component, but the mutual solubility of water and supercritical carbon dioxide was determined without regard to butanol in the solution. For reasons of simplicity and a lack of applicable data, the solubility of either substance in butanol was assumed negligible and not to affect the system enough to greatly change the outlet concentrations of either stream.

A study regarding high-pressure phase equilibrium of butanol, water and carbon dioxide provided comprehensive equilibrium data for systems with those three components, but there was not understanding of the behavior of the system in the reactor to use in-depth equilibrium data (Chen, Chang,

& Chen, 2002). The high-pressure phase equilibrium of butanol, water, and supercritical carbon dioxide in a fermentation reactor should be explored further in another project.

### **Turbine Separation Assumption**

As the extract stream passed through the turbine, it was assumed all supercritical carbon dioxide turned into gaseous carbon dioxide. This assumption is valid if specifically referencing the carbon dioxide phase diagram. However, the phase diagram for pure carbon dioxide does not account for the other components in the system. The solubility of carbon dioxide in the water or butanol phase was assumed negligible due to the fact that the mass of the butanol and water in the turbine only accounted for three percent of the total mass of the stream. If some carbon dioxide did remain dissolved in the butanol or water following expansion, this amount would not significantly affect the overall values for the energy analysis.

## Conclusion and Recommendations

Comparison of different in situ, continuous supercritical carbon dioxide extraction scenarios to common extraction methods showed that in situ, continuous supercritical carbon dioxide extraction was the most energy efficient, especially when carbon dioxide at 100 bar and 40 °C was already available. At these conditions, the energy cost to produce 1 kilogram of butanol is 3.01 MJ. The extraction with the next lowest energy cost is liquid-liquid extraction and requires 9 MJ to produce 1 kilogram of butanol. This method is almost an order of magnitude more efficient than liquid-liquid extraction, but it is recognized that this result is not completely precise.

Several concerns regarding process assumptions were identified in the results and discussion section. Although the validity of assumptions was justified and consequences considered, we believe these consequences would have minimal effects on the final energy of production value. We recommend that an investigation be conducted to validate the minimal effects of our assumptions on the overall process. We also recommend that an investigation be conducted on the reactor conditions to refine our assumptions and the reactor conditions to optimize energy and butanol production. We recommend that an optimization be conducted on the compressor staging and column parameters to reduce energy use and enhance butanol separation. Lastly, we recommend that a heat exchanger network be designed to conserve energy transferred to cooling and heating streams.

Beyond testing the validity of our assumptions, we also recommend that a prototype of the process be built and tested to determine and improve upon the practical application of the process design, as the accumulation of all recommendations.

As originally discussed in the introduction, there is a strong need to create innovative solutions to tackle the issue of climate change and the need for sustainability in the energy production market. In situ continuous extraction with supercritical carbon dioxide is most relevant in waste reduction through the utilization of different industrial and municipal waste streams to produce energy through the butanol fermentation process. Any industrial facility or community that has a high output of organic waste could benefit from the implementation of a butanol fermentation process given that the results of this paper are verified with a pilot-scale process.

## References

- Chen, H. I., Chang, H. Y., & Chen, P. H. (2002). High-pressure phase equilibria of carbon dioxide + 1-butanol, and carbon dioxide + water + 1-butanol systems. *Journal of Chemical and Engineering Data*, 47(4), 776–780. doi:10.1021/je010237q
- Energy Information Administration. (2015). How much ethanol is produced, imported, and consumed in the United States? - FAQ - U.S. Energy Information Administration (EIA). Retrieved February 29, 2016, from <http://www.eia.gov/tools/faqs/faq.cfm?id=90&t=4>
- Grose, T. K. (2001). Whisky a Go Go: Can Scotland's Distillery Waste Boost Biofuels? Retrieved December 21, 2015, from <http://news.nationalgeographic.com/news/energy/2013/06/130614-scotland-whisky-waste-to-biofuel/>
- Güvenç, A., Mehmetoglu, Ü., & Calimli, A. (1998). Supercritical CO<sub>2</sub> extraction of ethanol from fermentation broth in a semicontinuous system. *The Journal of Supercritical Fluids*, 13, 325–329. Retrieved from <http://www.sciencedirect.com/science/article/pii/S0896844698000679>
- Khosravi-Darani, K., & Vasheghani-Farahani, E. (2005). Application of supercritical fluid extraction in biotechnology. *Critical Reviews in Biotechnology*, 25(4), 231–42. doi:10.1080/07388550500354841
- King, M. B., Mubarak, A., Kim, J. D., & Bott, T. R. (1992). The mutual solubilities of water with supercritical and liquid carbon dioxides. *The Journal of Supercritical Fluids*, 5(4), 296–302. doi:10.1016/0896-8446(92)90021-B
- Laitinen, A., & Kaunisto, J. (1999a). Oldshue–Rushton Column in Supercritical Fluid Extraction. *Separation Science and Technology*, 34(9), 1859–1872. doi:10.1081/SS-100100743
- Laitinen, A., & Kaunisto, J. (1999b). Supercritical fluid extraction of 1-butanol from aqueous solutions. *Journal of Supercritical Fluids*, 15, 245–252. doi:10.1016/S0896-8446(99)00011-X
- Oudshoorn, A. (2012). *Recovery of bio-based butanol*. Retrieved from <http://repository.tudelft.nl/view/ir/uuid:e95e5738-6b73-4d59-a4f6-225211b27958/>
- Oudshoorn, A., Van Der Wielen, L. A. M., & Straathof, A. J. J. (2009). Assessment of options for selective 1-butanol recovery from aqueous solution. *Industrial and Engineering Chemistry Research*, 48(15), 7325–7336. doi:10.1021/ie900537w
- Peralta, E. (2015). Obama On Climate Change: “I Actually Think We’re Going To Solve This Thing” : The Two-Way : NPR. Retrieved December 21, 2015, from <http://www.npr.org/sections/thetwo-way/2015/12/01/457986043/obama-urges-turkey-russia-to-lesser-tensions-focus-on-islamic-state-fight>
- Qureshi, N., Hughes, S., Maddox, I. S., & Cotta, M. A. (2005). Energy-efficient recovery of butanol from model solutions and fermentation broth by adsorption. *Bioprocess and Biosystems Engineering*, 27(4), 215–222. doi:10.1007/s00449-005-0402-8
- Ranjan, A., & Moholkar, V. S. (2012). Biobutanol: science, engineering, and economics. *International Journal of Energy Research*, 36(3), 277–323. doi:10.1002/er.1948
- Tenenbaum, L., & Shaftel, H. (2015). Scientific Consensus: Earth's Climate Is Warming. Retrieved December 21, 2015, from <http://climate.nasa.gov/scientific-consensus/>
- The New York Times. (2015). The Road to a Paris Climate Deal. Retrieved December 21, 2015, from



<http://www.nytimes.com/interactive/projects/cp/climate/2015-paris-climate-talks>

Turton, Richard., et al. *Analysis, Synthesis, and Design of Chemical Processes*. Fourth ed. Upper Saddle River, NJ: Prentice Hall, 2012. Print.

Weizmann, C. (1919, September 9). Production of Acetone and Alcohol by Bacteriological Processes. United States Patent Office. Retrieved from <http://www.google.com/patents/US1315585>

Zverlov, V. V, Berezina, O., Velikodvorskaya, G. A., & Schwarz, W. H. (2006). Bacterial acetone and butanol production by industrial fermentation in the Soviet Union: use of hydrolyzed agricultural waste for biorefinery. *Applied Microbiology and Biotechnology*, 71(5), 587–97.  
doi:10.1007/s00253-006-0445-z

## Appendix A – Calculations

### Butanol Fermentation in Reactor

#### Fermentation Products

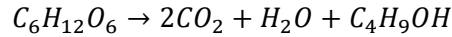

0.104 kg/h butanol produced in reactor instead of as 5 wt% of initial feed.

Molar mass of butanol = 0.074 kg/mol

$$0.104 \frac{kg}{h} * 0.074 \frac{kg}{mol} = 1.41 \frac{mol}{h}$$

Species	Glucose	Carbon Dioxide	Water	Butanol
<b>Mole balance</b>	1.41 mol/h	2.82 mol/h	1.41 mol/h	1.41 mol/h
<b>Molar mass</b>	0.180 kg/mol	0.044 kg/mol	0.018 kg/mol	0.074 kg/mol
<b>Mass of each species produced in reactor</b>	0.254 kg/h	0.124 kg/h	0.025 kg/h	0.104 kg/h

#### Heat of Fermentation

Species	Glucose	Carbon Dioxide	Water	Butanol
<b>Heat of Formation H<sup>f</sup> (kJ/mol)</b>	-1275	-393.5	-285.8	-327

$$H^f = \sum H_{prod}^f - \sum H_{react}^f$$

$$H^f = 2 * \left(-393.5 \frac{kJ CO_2}{mol}\right) + \left(-285.8 \frac{kJ H_2O}{mol}\right) + \left(-327 \frac{kJ C_4H_9OH}{mol}\right) + \left(1275 \frac{kJ C_6H_{12}O_6}{mol}\right)$$

$$H^f = -124.8 \frac{kJ}{mol} * 1.41 \frac{mol}{h} = -176.3 \frac{kJ}{h}$$

#### Temperature Increase in Reactor Due to Fermentation

$$Q = \dot{m} * c_p * (T_f - T_i)$$

Q = heat released by fermentation = H<sup>f</sup> = 176.3 kJ/h

We assumed the mass in the reactor is constant at 5.4 kg/h CO<sub>2</sub> (0.72 wt%) + 0.104 kg/h C<sub>4</sub>H<sub>9</sub>OH (0.01 wt%) + 1.98 kg/h H<sub>2</sub>O (0.27 wt%) = 7.484 kg/h

We determined the weighted average specific heat (*c<sub>p</sub>*) at 40 °C:

Species	Glucose	Carbon Dioxide	Water	Butanol
<b>Specific Heat (<i>c<sub>p</sub></i>) at 40 °C (kJ/kgK)</b>	N/A (consumed by bacteria)	5.59	4.179	2.509

$$c_p = 0.72 * \left(5.59 \frac{kJ}{kgK}\right) + 0.27 * \left(4.179 \frac{kJ}{kgK}\right) + 0.01 * \left(2.509 \frac{kJ}{kgK}\right)$$

$$c_p = 5.178 \frac{kJ}{kgK}$$

Starting reactor temperature *T<sub>i</sub>* = 40 °C

<i>Q</i> = 176.3 kJ/h	<i>m</i> = 7.484 kg/h	<i>c<sub>p</sub></i> = 5.178 kJ/kgK @ 40 °C	<i>T<sub>i</sub></i> = 40 °C
-----------------------	-----------------------	---------------------------------------------	------------------------------

$$T_f = 44.5 \text{ °C}$$

## Mutual Solubilities of Carbon Dioxide and Water Water in Carbon Dioxide Phase (Extract)

Solubility of water in carbon dioxide phase at 40 °C = 4.28 mol water per 1000 mol carbon dioxide

$$\frac{4.28 \text{ mol } H_2O}{1000 \text{ mol } CO_2} * \frac{1 \text{ mol } CO_2}{0.044 \text{ kg } CO_2} * \frac{0.018 \text{ kg } H_2O}{1 \text{ mol } H_2O} = \frac{0.00175 \text{ kg } H_2O}{1 \text{ kg } CO_2}$$

$$A \text{ kg } H_2O = 0.00175 * B \text{ kg } CO_2 \quad \text{(EQ 1)}$$

The total extract flow rate is 5.3 kg/h (Laitinen & Kaunisto, 1999b). If 99.7% of the total butanol produced is obtained in the extract:

$$0.997 * 0.104 \frac{kg}{h} BuOH = 0.1037 \frac{kg}{h} BuOH \text{ in Extract}$$

We assume the rest of the extract is the sum of the flow rates of carbon dioxide and water:

$$5.3 \text{ kg Extract} - 0.1037 \text{ kg BuOH} = 5.196 \text{ kg}$$

$$5.196 \text{ kg Extract} = A \text{ kg } H_2O + B \text{ kg } CO_2 \quad \text{(EQ 2)}$$

Solve EQ 1 and EQ 2:

$$A = 0.00908 \frac{kg}{h} H_2O$$

$$B = 5.187 \frac{kg}{h} CO_2$$

### Carbon Dioxide in Water Phase (Raffinate)

Solubility of carbon dioxide in water phase at 40 °C = 2.14 mol carbon dioxide per 100 mol water.

$$\frac{2.14 \text{ mol } CO_2}{100 \text{ mol } H_2O} * \frac{1 \text{ mol } CO_2}{0.044 \text{ kg } CO_2} * \frac{0.018 \text{ kg } H_2O}{1 \text{ mol } H_2O} = \frac{0.00874 \text{ kg } CO_2}{1 \text{ kg } H_2O}$$

$$C \text{ kg } CO_2 = 0.00874 * D \text{ kg } H_2O \quad (\text{EQ 3})$$

The total raffinate flow rate is 1.91 kg/h. We assumed the remaining mass of butanol not obtained in the extract leaves the process in the raffinate:

$$0.104 \frac{kg}{h} - 0.1037 \frac{kg}{h} = 0.0003 \frac{kg}{h} \text{ BuOH in Raffinate}$$

We assume the rest of the raffinate is the sum of the flow rates of carbon dioxide and water:

$$1.91 \text{ kg Raffinate} - 0.0003 \text{ kg BuOH} = 1.9097 \text{ kg}$$

$$1.9097 \text{ kg Raffinate} = C \text{ kg } CO_2 + D \text{ kg } H_2O \quad (\text{EQ 4})$$

Solve EQ 3 and EQ 4:

$$C = 0.0165 \frac{kg}{h} CO_2$$

$$D = 1.893 \frac{kg}{h} H_2O$$

## Recycle Stream Temperatures

### After Recycle Turbine

SC CO<sub>2</sub> @ 100 bar, 40 °C → CO<sub>2</sub> gas @ 50 bar, 40 °C

$$\frac{T_2}{T_1} = \left(\frac{P_2}{P_1}\right)^{(1-\frac{1}{\gamma})}$$

$$y = \frac{c_p}{c_v}$$

$$y = \frac{0.846 \frac{kJ}{kgK}}{0.655 \frac{kJ}{kgK}} = 1.29$$

$T_1 = 40 \text{ °C}$	$P_1 = 100 \text{ bar}$	$P_2 = 50 \text{ bar}$	$y = 1.29$
-----------------------	-------------------------	------------------------	------------

$$T_2 = 34.2 \text{ °C}$$

### After Recycle Compressor

CO<sub>2</sub> gas @ 50 bar, 34.2 °C → 100 bar, T<sub>2</sub> °C

$$\frac{T_2}{T_1} = \left(\frac{P_2}{P_1}\right)^{(1-\frac{1}{\gamma})}$$

$T_1 = 40 \text{ °C}$	$P_1 = 100 \text{ bar}$	$P_2 = 50 \text{ bar}$	$\gamma = 1.29$
-----------------------	-------------------------	------------------------	-----------------

$$T_2 = 39.97 \text{ °C}$$

### Energy Balance Calculations

#### Turbine

SC CO<sub>2</sub> @ 100 bar, 40 °C → CO<sub>2</sub> gas @ 50 bar, 40 °C

$$W_T = \eta * \dot{m} * (H_{in} - H_{out})$$

$\eta = 0.95$	$\dot{m} = 5.187 \text{ kg/h}$	$H_{in} = 313 \text{ kJ/kg}$	$H_{out} = 467 \text{ kJ/kg}$
---------------	--------------------------------	------------------------------	-------------------------------

$$W_T = -758.9 \frac{\text{kJ}}{\text{h}}$$

#### Recycle Compressor

CO<sub>2</sub> gas @ 50 bar, 40 °C → 100 bar, 40 °C

$$W_C = \frac{\dot{m} * (H_{in} - H_{out})}{\eta}$$

$\eta = 0.88$	$\dot{m} = 5.187 \text{ kg/h}$	$H_{in} = 467 \text{ kJ/kg}$	$H_{out} = 313 \text{ kJ/kg}$
---------------	--------------------------------	------------------------------	-------------------------------

$$W_C = 907.7 \frac{\text{kJ}}{\text{h}}$$

#### Feed Compressor

CO<sub>2</sub> gas @ 1 bar, 25 °C → 100 bar, 25 °C

$$W_C = \frac{\dot{m} * (H_{in} - H_{out})}{\eta}$$

$\eta = 0.88$	$\dot{m} = 0.089 \text{ kg/h}$	$H_{in} = 506 \text{ kJ/kg}$	$H_{out} = 313 \text{ kJ/kg}$
---------------	--------------------------------	------------------------------	-------------------------------

$$W_C = 19.5 \frac{\text{kJ}}{\text{h}}$$

#### Feed Heat Exchanger

CO<sub>2</sub> gas @ 100 bar, 25 °C → 100 bar, 40 °C

$$Q_E = \dot{m} * c_p * (T_{out} - T_{in})$$

$$\dot{m} = 0.089 \text{ kg/h}$$

$$c_p = 0.846 \text{ kJ/kgK @ } 25 \text{ }^\circ\text{C}$$

$$T_{out} = 40 \text{ }^\circ\text{C}$$

$$T_{in} = 25 \text{ }^\circ\text{C}$$

$$Q_E = 1.1 \frac{\text{kJ}}{\text{h}}$$

## Appendix B – Energy Requirements for Varying Situations

**TABLE 6: ENERGY REQUIREMENT OF HEAT EXCHANGER UNITS: INITIAL 1 BAR, 25 °C CARBON DIOXIDE FEED STREAM**

Unit	Description	Energy Requirement (MJ/h)
<b>Heat Exchangers in Staged Compression Series</b>	Heat required to maintain stream temperature below 400°F	-0.009 -0.014
<b>Feed Heat Exchanger</b>	Heat carbon dioxide at 100 bar and 25 °C to 100 bar and 40 °C to match conditions for reactor	-0.583
	<b>Total:</b>	/ 0.0395 kg/h bottoms product (wt% butanol)
	<b>MJ/kg Product:</b>	<b>-15.3</b>

**TABLE 7: ENERGY REQUIREMENT OF UNITS: INITIAL 100 BAR, 25 °C CARBON DIOXIDE FEED STREAM**

Unit	Description	Energy Requirement (MJ/h)
<b>Staged Compressors</b>	Compress carbon dioxide at 1 bar and 25 °C to 100 bar and 25 °C	N/A
<b>Heat of Fermentation</b>	Heat released during fermentation in reactor	- 0.176
<b>Reactor</b>	Work required to operate reactor	0.099
<b>Turbine (isentropic)</b>	Separation of SC carbon dioxide from butanol water by reducing pressure from 100 bar to 50 bar	- 0.043
<b>Recycle Compressor (isentropic)</b>	Recompress carbon dioxide from 50 bar to 100 bar	0.109
<b>Column Condenser</b>	Energy required to condense distillate water-butanol mixture	-0.055
<b>Column Reboiler</b>	Energy required to vaporize bottoms butanol-water mixture	0.185
	<b>Total:</b>	/ 0.0395 kg/h bottoms product (wt% butanol)

	<b>MJ/kg Product:</b>	<b>3.01</b>
--	-----------------------	-------------

**TABLE 8: ENERGY REQUIREMENT OF HEAT EXCHANGER UNITS: INITIAL 100 BAR, 25 °C CARBON DIOXIDE FEED STREAM**

Unit	Description	Energy Requirement (MJ/h)
<b>Heat Exchangers in Staged Compression Series</b>	Heat required to maintain stream temperature below 400°F	N/A
<b>Feed Heat Exchanger</b>	Heat carbon dioxide at 100 bar and 25 °C to 100 bar and 40 °C to match conditions for reactor	-0.549
	<b>Total:</b>	/ 0.0395 kg/h bottoms product (wt% butanol)
	<b>MJ/kg Product:</b>	<b>-13.9</b>

**TABLE 9: ENERGY REQUIREMENT OF UNITS: INITIAL 100 BAR, 40 °C CARBON DIOXIDE FEED STREAM**

Unit	Description	Energy Requirement (MJ/h)
<b>Staged Compressors</b>	Compress carbon dioxide at 1 bar and 25 °C to 100 bar and 25 °C	N/A
<b>Heat of Fermentation</b>	Heat released during fermentation in reactor	- 0.176
<b>Reactor</b>	Work required to operate reactor	0.099
<b>Turbine (isentropic)</b>	Separation of SC carbon dioxide from butanol water by reducing pressure from 100 bar to 50 bar	- 0.043
<b>Recycle Compressor (isentropic)</b>	Recompress carbon dioxide from 50 bar to 100 bar	0.109
<b>Column Condenser</b>	Energy required to condense distillate water-butanol mixture	-0.055
<b>Column Reboiler</b>	Energy required to vaporize bottoms butanol-water mixture	0.185
	<b>Total:</b>	/ 0.0395 kg/h bottoms product (wt% butanol)



	<b>MJ/kg Product:</b>	<b>3.01</b>
--	-----------------------	-------------

**TABLE 10: ENERGY REQUIREMENT OF HEAT EXCHANGER UNITS: INITIAL 100 BAR, 40 °C CARBON DIOXIDE FEED STREAM**

Unit	Description	Energy Requirement (MJ/h)
<b>Heat Exchangers in Staged Compression Series</b>	Heat required to maintain stream temperature below 400°F	N/A
<b>Feed Heat Exchanger</b>	Heat carbon dioxide at 100 bar and 25 °C to 100 bar and 40 °C to match conditions for reactor	-0.555
	<b>Total:</b>	/ 0.0395 kg/h bottoms product (wt% butanol)
	<b>MJ/kg Product:</b>	<b>-14.0</b>

# Appendix C – Aspen Process Diagrams

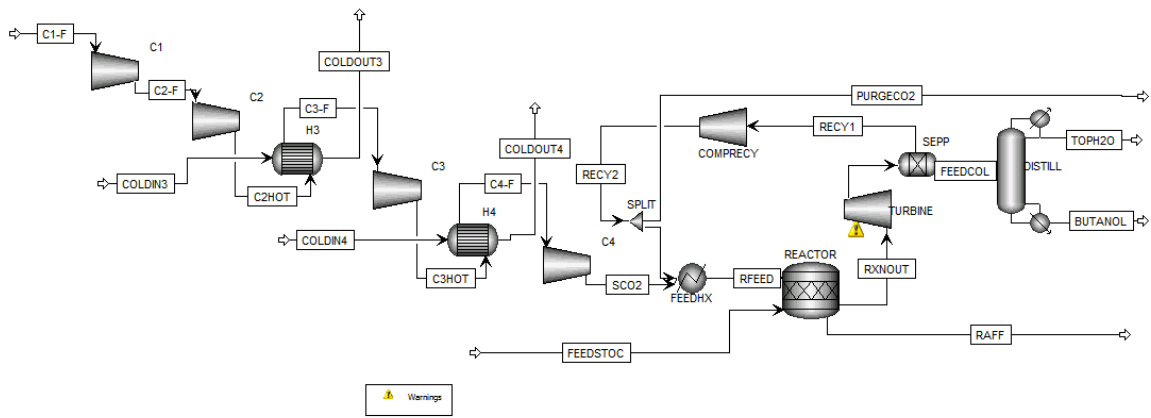

**FIGURE 6: ASPEN PROCESS DIAGRAM FOR 1 BAR, 25 °C CARBON DIOXIDE FEED**

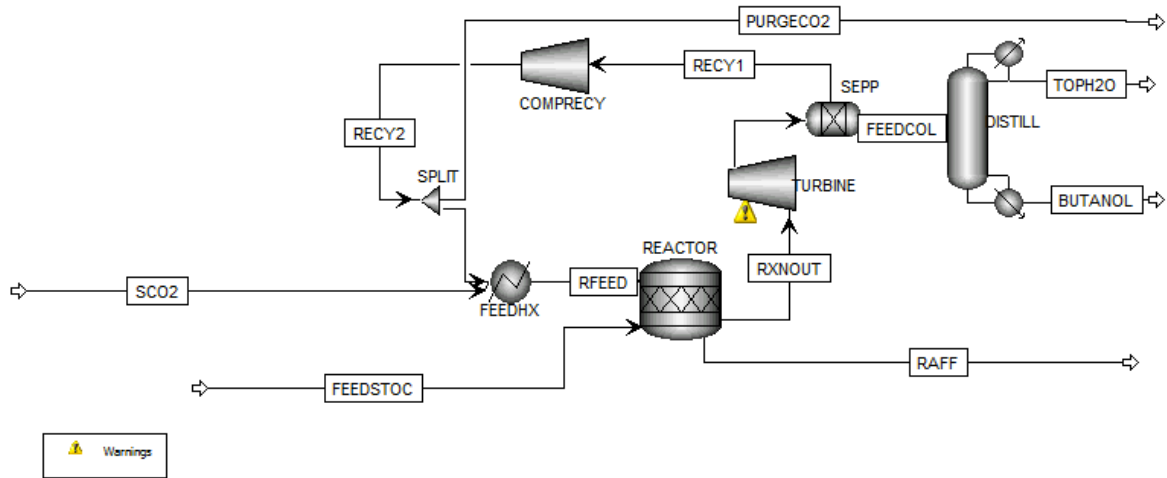

**FIGURE 7: ASPEN PROCESS DIAGRAM FOR 100 BAR, 25 °C AND 100 BAR, 40 °C CARBON DIOXIDE FEED**

## Appendix D – Aspen Input File

### Aspen Input File for 1 bar, 25°C Carbon Dioxide Feed Scenario

```
;
;Input Summary created by Aspen Plus Rel. 34.0 at 03:26:37 Thu Apr 28, 2016
;Directory R:\MQP\butanol-final1_2 Filename R:\MQP\butanol-final1 input.inp
;
DYNAMICS
  DYNAMICS RESULTS=ON
IN-UNITS MET PRESSURE=bar TEMPERATURE=C DELTA-T=C PDROP=bar &
  INVERSE-PRES='1/bar'
DEF-STREAMS CONVEN ALL
MODEL-OPTION
DATABANKS 'APV88 PURE32' / 'APV88 AQUEOUS' / 'APV88 SOLIDS' / &
  'APV88 INORGANIC' / 'APEOSV88 AP-EOS' / NOASPENPCD
PROP-SOURCES 'APV88 PURE32' / 'APV88 AQUEOUS' / 'APV88 SOLIDS' &
  / 'APV88 INORGANIC' / 'APEOSV88 AP-EOS'
COMPONENTS
  CO2 CO2 /
  WATER H2O /
  BUTANOL C4H10O-1 /
  GLUCOSE C6H12O6
SOLVE
  RUN-MODE MODE=SIM
FLOWSHEET
  BLOCK FEEDHX IN=RECY3 SCO2 OUT=RFEED
  BLOCK REACTOR IN=FEEDSTOC RFEED OUT=RXNOUT RAFF
  BLOCK TURBINE IN=RXNOUT OUT=RECYCLE
  BLOCK COMPRECY IN=RECY1 OUT=RECY2
  BLOCK SEPP IN=RECYCLE OUT=RECY1 FEEDCOL
  BLOCK SPLIT IN=RECY2 OUT=RECY3 PURGECO2
  BLOCK DISTILL IN=FEEDCOL OUT=TOPH2O BUTANOL
  BLOCK C4 IN=C4-F OUT=SCO2
  BLOCK C3 IN=C3-F OUT=C3HOT
  BLOCK C2 IN=C2-F OUT=C2HOT
  BLOCK C1 IN=C1-F OUT=C2-F
  BLOCK H4 IN=C3HOT COLDIN4 OUT=C4-F COLDOUT4
  BLOCK H3 IN=C2HOT COLDIN3 OUT=C3-F COLDOUT3
PROPERTIES LK-PLOCK
  PROPERTIES BWRS / COSMOSAC / NRTL / PENG-ROB / RK-ASPEN /
  RK-SOAVE / RKSMHV2 / SR-POLAR / SRK / STEAMNBS /
  UNIF-LL / WILS-RK
PROP-DATA BWRKT-1
  IN-UNITS MET PRESSURE=bar TEMPERATURE=C DELTA-T=C PDROP=bar &
  INVERSE-PRES='1/bar'
  PROP-LIST BWRKT
  BPVAL CO2 WATER -.0795000000
  BPVAL WATER CO2 -.0795000000
PROP-DATA BWRKV-1
  IN-UNITS MET PRESSURE=bar TEMPERATURE=C DELTA-T=C PDROP=bar &
  INVERSE-PRES='1/bar'
```

PROP-LIST BWRKV  
 BPVAL CO2 WATER .0605100000  
 BPVAL WATER CO2 .0605100000  
 PROP-DATA HOCETA-1  
 IN-UNITS MET PRESSURE=bar TEMPERATURE=C DELTA-T=C PDROP=bar &  
 INVERSE-PRES='1/bar'  
 PROP-LIST HOCETA  
 BPVAL CO2 CO2 .1600000000  
 BPVAL CO2 WATER .3000000000  
 BPVAL CO2 BUTANOL .3000000000  
 BPVAL WATER CO2 .3000000000  
 BPVAL WATER WATER 1.700000000  
 BPVAL WATER BUTANOL 1.550000000  
 BPVAL BUTANOL CO2 .3000000000  
 BPVAL BUTANOL WATER 1.550000000  
 BPVAL BUTANOL BUTANOL 2.200000000  
 PROP-DATA LKPKIJ-1  
 IN-UNITS MET PRESSURE=bar TEMPERATURE=C DELTA-T=C PDROP=bar &  
 INVERSE-PRES='1/bar'  
 PROP-LIST LKPKIJ  
 BPVAL CO2 WATER -.0633000000  
 BPVAL WATER CO2 -.0633000000  
 PROP-DATA NRTL-1  
 IN-UNITS MET PRESSURE=bar TEMPERATURE=C DELTA-T=C PDROP=bar &  
 INVERSE-PRES='1/bar'  
 PROP-LIST NRTL  
 BPVAL WATER BUTANOL 13.11020000 -3338.953600 .3000000000 &  
 0.0 0.0 0.0 19.17000000 117.6000000  
 BPVAL BUTANOL WATER -2.040500000 763.8692000 .3000000000 &  
 0.0 0.0 0.0 19.17000000 117.6000000  
 PROP-DATA PRKBV-1  
 IN-UNITS MET PRESSURE=bar TEMPERATURE=C DELTA-T=C PDROP=bar &  
 INVERSE-PRES='1/bar'  
 PROP-LIST PRKBV  
 BPVAL CO2 WATER .1200000000 0.0 0.0 -273.1500000 &  
 726.8500000  
 BPVAL WATER CO2 .1200000000 0.0 0.0 -273.1500000 &  
 726.8500000  
 PROP-DATA RKSKBV-1  
 IN-UNITS MET PRESSURE=bar TEMPERATURE=C DELTA-T=C PDROP=bar &  
 INVERSE-PRES='1/bar'  
 PROP-LIST RKSKBV  
 BPVAL CO2 WATER .0737000000 0.0 0.0 -273.1500000 &  
 726.8500000  
 BPVAL WATER CO2 .0737000000 0.0 0.0 -273.1500000 &  
 726.8500000  
 PROP-DATA WILSON-1  
 IN-UNITS MET PRESSURE=bar TEMPERATURE=C DELTA-T=C PDROP=bar &  
 INVERSE-PRES='1/bar'  
 PROP-LIST WILSON  
 BPVAL WATER BUTANOL .6102000000 -420.6027000 0.0 0.0 &

19.17000000 191.8000000 0.0  
 BPVAL BUTANOL WATER 2.450400000 -2492.023400 0.0 0.0 &  
 19.17000000 191.8000000 0.0  
 STREAM C1-F  
 SUBSTREAM MIXED TEMP=25. PRES=1. MASS-FLOW=0.089  
 MASS-FRAC CO2 1.  
 STREAM COLDIN3  
 SUBSTREAM MIXED TEMP=75. <F> PRES=1. MASS-FLOW=0.2  
 MASS-FRAC CO2 1.  
 STREAM COLDIN4  
 SUBSTREAM MIXED TEMP=75. <F> PRES=1. MASS-FLOW=0.4  
 MASS-FRAC WATER 1.  
 STREAM FEEDSTOC  
 SUBSTREAM MIXED TEMP=40.00000000 PRES=100.0000000 &  
 MASS-FLOW=2.210000000  
 MASS-FRAC WATER 0.885 / GLUCOSE 0.115  
 BLOCK SPLIT FSPLIT  
 FRAC PURGECO2 0.05  
 BLOCK SEPP SEP  
 PARAM MAXIT=50 TOL=0.001  
 FRAC STREAM=RECY1 SUBSTREAM=MIXED COMPS=CO2 FRACS=1.  
 BLOCK FEEDHX HEATER  
 PARAM TEMP=40.00000000 PRES=100.0000000 DPPARMOPT=NO  
 BLOCK H3 HEATX  
 PARAM T-HOT=70. MIN-TAPP=10.  
 FEEDS HOT=C2HOT COLD=COLDIN3  
 OUTLETS-HOT C3-F  
 OUTLETS-COLD COLDOUT3  
 HOT-SIDE DPPARMOPT=NO  
 COLD-SIDE DPPARMOPT=NO  
 TQ-PARAM CURVE=YES  
 BLOCK H4 HEATX  
 PARAM T-HOT=45. MIN-TAPP=20.  
 FEEDS HOT=C3HOT COLD=COLDIN4  
 OUTLETS-HOT C4-F  
 OUTLETS-COLD COLDOUT4  
 HOT-SIDE DPPARMOPT=NO  
 COLD-SIDE DPPARMOPT=NO  
 TQ-PARAM CURVE=YES  
 BLOCK DISTILL RADFRAC  
 PARAM NSTAGE=10 ALGORITHM=STANDARD MAXOL=25 DAMPING=NONE  
 COL-CONFIG CONDENSER=TOTAL  
 FEEDS FEEDCOL 2  
 PRODUCTS TOPH2O 1 L / BUTANOL 10 L  
 P-SPEC 1 50.  
 COL-SPECS MASS-D:F=0.7 QN=185.5 <kJ/hr>  
 BLOCK REACTOR RSTOIC  
 PARAM TEMP=40.00000000 PRES=100.0000000 MAXIT=100 TOL=0.001  
 STOIC 1 MIXED GLUCOSE -1. / CO2 2. / WATER 1. / &  
 BUTANOL 1.  
 CONV 1 MIXED GLUCOSE 1.

```

PROPERTIES SRK FREE-WATER=STEAM-TA SOLU-WATER=3 &
  TRUE-COMPS=YES
BLOCK-OPTION FREE-WATER=YES
BLOCK C1 COMPR
  PARAM TYPE=ISENTROPIC PRES=3. SEFF=0.86 SB-MAXIT=30 &
  SB-TOL=0.0001
BLOCK C2 COMPR
  PARAM TYPE=ISENTROPIC PRES=6. SEFF=0.86 SB-MAXIT=30 &
  SB-TOL=0.0001
BLOCK C3 COMPR
  PARAM TYPE=ISENTROPIC PRES=24. SEFF=0.86 SB-MAXIT=30 &
  SB-TOL=0.0001
BLOCK C4 COMPR
  PARAM TYPE=ISENTROPIC PRES=100. SEFF=0.86 SB-MAXIT=30 &
  SB-TOL=0.0001
BLOCK COMPRECY COMPR
  PARAM TYPE=ISENTROPIC PRES=100. SEFF=1. MEFF=1. NPHASE=2 &
  SB-MAXIT=50 SB-TOL=0.0001
  BLOCK-OPTION FREE-WATER=DIRTY
BLOCK TURBINE COMPR
  PARAM TYPE=ISENTROPIC PRES=50. SEFF=1. MEFF=1. NPHASE=2 &
  SB-MAXIT=100 SB-TOL=0.0001 MODEL-TYPE=TURBINE
  PROPERTIES RK-SOAVE FREE-WATER=STEAM-TA SOLU-WATER=1 &
  TRUE-COMPS=YES
  BLOCK-OPTION RESTART=YES FREE-WATER=DIRTY FLASH-METHOD=GIBBS
EO-CONV-OPTI
SENSITIVITY S-1
  DEFINE BUTANOL MASS-FRAC STREAM=BUTANOL SUBSTREAM=MIXED &
  COMPONENT=BUTANOL
  TABULATE 1 "BUTANOL"
  VARY BLOCK-VAR BLOCK=DISTILL VARIABLE=NSTAGE SENTENCE=PARAM
  RANGE LOWER="1" UPPER="15" INCR="0.5"
STREAM-REPOR MOLEFLOW MASSFLOW MASSFRAC
PROPERTY-REP PCES
;
;
;
;
;
;
;
;
;
;

```

## Aspen Input File for 100 bar, 25°C Carbon Dioxide Feed Scenario

```
;  
;Input Summary created by Aspen Plus Rel. 34.0 at 03:31:54 Thu Apr 28, 2016  
;Directory R:\MQP\butanol-final3 Filename R:\MQP\butanol-final3 input.inp  
;  
  
DYNAMICS  
  DYNAMICS RESULTS=ON  
IN-UNITS MET PRESSURE=bar TEMPERATURE=C DELTA-T=C PDROP=bar &  
  INVERSE-PRES='1/bar'  
DEF-STREAMS CONVEN ALL  
MODEL-OPTION  
DATABANKS 'APV88 PURE32' / 'APV88 AQUEOUS' / 'APV88 SOLIDS' / &  
  'APV88 INORGANIC' / 'APEOSV88 AP-EOS' / NOASPENPCD  
PROP-SOURCES 'APV88 PURE32' / 'APV88 AQUEOUS' / 'APV88 SOLIDS' &  
  / 'APV88 INORGANIC' / 'APEOSV88 AP-EOS'  
COMPONENTS  
  CO2 CO2 /  
  WATER H2O /  
  BUTANOL C4H10O-1 /  
  GLUCOSE C6H12O6  
SOLVE  
  RUN-MODE MODE=SIM  
FLOWSHEET  
  BLOCK FEEDHX IN=RECY3 SCO2 OUT=RFEED  
  BLOCK REACTOR IN=FEEDSTOC RFEED OUT=RXNOUT RAFF  
  BLOCK TURBINE IN=RXNOUT OUT=RECYCLE  
  BLOCK COMPRECY IN=RECY1 OUT=RECY2  
  BLOCK SEPP IN=RECYCLE OUT=RECY1 FEEDCOL  
  BLOCK SPLIT IN=RECY2 OUT=RECY3 PURGECO2  
  BLOCK DISTILL IN=FEEDCOL OUT=TOPH2O BUTANOL  
PROPERTIES LK-PLOCK  
  PROPERTIES BWRS / COSMOSAC / NRTL / PENG-ROB / RK-ASPEN /  
  RK-SOAVE / RKSMHV2 / SR-POLAR / SRK / STEAMNBS /  
  UNIF-LL / WILS-RK  
PROP-DATA BWRKT-1  
  IN-UNITS MET PRESSURE=bar TEMPERATURE=C DELTA-T=C PDROP=bar &  
  INVERSE-PRES='1/bar'  
  PROP-LIST BWRKT  
  BPVAL CO2 WATER -.0795000000  
  BPVAL WATER CO2 -.0795000000  
PROP-DATA BWRKV-1  
  IN-UNITS MET PRESSURE=bar TEMPERATURE=C DELTA-T=C PDROP=bar &  
  INVERSE-PRES='1/bar'  
  PROP-LIST BWRKV  
  BPVAL CO2 WATER .0605100000  
  BPVAL WATER CO2 .0605100000  
PROP-DATA HOCETA-1  
  IN-UNITS MET PRESSURE=bar TEMPERATURE=C DELTA-T=C PDROP=bar &  
  INVERSE-PRES='1/bar'
```

PROP-LIST HOCETA  
 BPVAL CO2 CO2 .1600000000  
 BPVAL CO2 WATER .3000000000  
 BPVAL CO2 BUTANOL .3000000000  
 BPVAL WATER CO2 .3000000000  
 BPVAL WATER WATER 1.700000000  
 BPVAL WATER BUTANOL 1.550000000  
 BPVAL BUTANOL CO2 .3000000000  
 BPVAL BUTANOL WATER 1.550000000  
 BPVAL BUTANOL BUTANOL 2.200000000  
 PROP-DATA LKPKIJ-1  
 IN-UNITS MET PRESSURE=bar TEMPERATURE=C DELTA-T=C PDROP=bar &  
 INVERSE-PRES='1/bar'  
 PROP-LIST LKPKIJ  
 BPVAL CO2 WATER -.0633000000  
 BPVAL WATER CO2 -.0633000000  
 PROP-DATA NRTL-1  
 IN-UNITS MET PRESSURE=bar TEMPERATURE=C DELTA-T=C PDROP=bar &  
 INVERSE-PRES='1/bar'  
 PROP-LIST NRTL  
 BPVAL WATER BUTANOL 13.11020000 -3338.953600 .3000000000 &  
 0.0 0.0 0.0 19.17000000 117.6000000  
 BPVAL BUTANOL WATER -2.040500000 763.8692000 .3000000000 &  
 0.0 0.0 0.0 19.17000000 117.6000000  
 PROP-DATA PRKBV-1  
 IN-UNITS MET PRESSURE=bar TEMPERATURE=C DELTA-T=C PDROP=bar &  
 INVERSE-PRES='1/bar'  
 PROP-LIST PRKBV  
 BPVAL CO2 WATER .1200000000 0.0 0.0 -273.1500000 &  
 726.8500000  
 BPVAL WATER CO2 .1200000000 0.0 0.0 -273.1500000 &  
 726.8500000  
 PROP-DATA RKSKBV-1  
 IN-UNITS MET PRESSURE=bar TEMPERATURE=C DELTA-T=C PDROP=bar &  
 INVERSE-PRES='1/bar'  
 PROP-LIST RKSKBV  
 BPVAL CO2 WATER .0737000000 0.0 0.0 -273.1500000 &  
 726.8500000  
 BPVAL WATER CO2 .0737000000 0.0 0.0 -273.1500000 &  
 726.8500000  
 PROP-DATA WILSON-1  
 IN-UNITS MET PRESSURE=bar TEMPERATURE=C DELTA-T=C PDROP=bar &  
 INVERSE-PRES='1/bar'  
 PROP-LIST WILSON  
 BPVAL WATER BUTANOL .6102000000 -420.6027000 0.0 0.0 &  
 19.17000000 191.8000000 0.0  
 BPVAL BUTANOL WATER 2.450400000 -2492.023400 0.0 0.0 &  
 19.17000000 191.8000000 0.0  
 STREAM FEEDSTOC  
 SUBSTREAM MIXED TEMP=40.00000000 PRES=100.0000000 &  
 MASS-FLOW=2.210000000



MASS-FRAC WATER 0.885 / GLUCOSE 0.115  
 STREAM SCO2  
 SUBSTREAM MIXED TEMP=25. PRES=100. MASS-FLOW=0.089  
 MASS-FLOW CO2 1.  
 BLOCK SPLIT FSPLIT  
 FRAC PURGECO2 0.05  
 BLOCK SEPP SEP  
 PARAM MAXIT=50 TOL=0.001  
 FRAC STREAM=RECY1 SUBSTREAM=MIXED COMPS=CO2 FRACS=1.  
 BLOCK FEEDHX HEATER  
 PARAM TEMP=40.0000000 PRES=100.0000000 DPPARMOPT=NO  
 BLOCK DISTILL RADFRAC  
 PARAM NSTAGE=10 ALGORITHM=STANDARD MAXOL=25 DAMPING=NONE  
 COL-CONFIG CONDENSER=TOTAL  
 FEEDS FEEDCOL 2  
 PRODUCTS TOPH2O 1 L / BUTANOL 10 L  
 P-SPEC 1 50.  
 COL-SPECS MASS-D:F=0.7 QN=185.5 <kJ/hr>  
 BLOCK REACTOR RSTOIC  
 PARAM TEMP=40.0000000 PRES=100.0000000 MAXIT=100 TOL=0.001  
 STOIC 1 MIXED GLUCOSE -1. / CO2 2. / WATER 1. / &  
 BUTANOL 1.  
 CONV 1 MIXED GLUCOSE 1.  
 PROPERTIES SRK FREE-WATER=STEAM-TA SOLU-WATER=3 &  
 TRUE-COMPS=YES  
 BLOCK-OPTION FREE-WATER=YES  
 BLOCK COMPRECY COMPR  
 PARAM TYPE=ISENTROPIC PRES=100. SEFF=1. MEFF=1. NPHASE=2 &  
 SB-MAXIT=50 SB-TOL=0.0001  
 BLOCK-OPTION FREE-WATER=DIRTY  
 BLOCK TURBINE COMPR  
 PARAM TYPE=ISENTROPIC PRES=50. SEFF=1. MEFF=1. NPHASE=2 &  
 SB-MAXIT=100 SB-TOL=0.0001 MODEL-TYPE=TURBINE  
 PROPERTIES RK-SOAVE FREE-WATER=STEAM-TA SOLU-WATER=1 &  
 TRUE-COMPS=YES  
 BLOCK-OPTION RESTART=YES FREE-WATER=DIRTY FLASH-METHOD=GIBBS  
 EO-CONV-OPTI  
 SENSITIVITY S-1  
 DEFINE BUTANOL MASS-FRAC STREAM=BUTANOL SUBSTREAM=MIXED &  
 COMPONENT=BUTANOL  
 TABULATE 1 "BUTANOL"  
 VARY BLOCK-VAR BLOCK=DISTILL VARIABLE=NSTAGE SENTENCE=PARAM  
 RANGE LOWER="1" UPPER="15" INCR="0.5"  
 STREAM-REPOR MOLEFLOW MASSFLOW MASSFRAC  
 PROPERTY-REP PCES  
 ;  
 ;  
 ;  
 ;  
 ;  
 ;  
 ;  
 ;

## Aspen Input File for 100 bar, 40°C Carbon Dioxide Feed Scenario

```
;  
;Input Summary created by Aspen Plus Rel. 34.0 at 03:34:22 Thu Apr 28, 2016  
;Directory R:\MQP\butanol-final4 Filename R:\MQP\butanol-final4 input.inp  
;  
  
DYNAMICS  
  DYNAMICS RESULTS=ON  
IN-UNITS MET PRESSURE=bar TEMPERATURE=C DELTA-T=C PDROP=bar &  
  INVERSE-PRES='1/bar'  
DEF-STREAMS CONVEN ALL  
MODEL-OPTION  
DATABANKS 'APV88 PURE32' / 'APV88 AQUEOUS' / 'APV88 SOLIDS' / &  
  'APV88 INORGANIC' / 'APEOSV88 AP-EOS' / NOASPENPCD  
PROP-SOURCES 'APV88 PURE32' / 'APV88 AQUEOUS' / 'APV88 SOLIDS' &  
  / 'APV88 INORGANIC' / 'APEOSV88 AP-EOS'  
COMPONENTS  
  CO2 CO2 /  
  WATER H2O /  
  BUTANOL C4H10O-1 /  
  GLUCOSE C6H12O6  
SOLVE  
  RUN-MODE MODE=SIM  
FLOWSHEET  
  BLOCK FEEDHX IN=RECY3 SCO2 OUT=RFEED  
  BLOCK REACTOR IN=FEEDSTOC RFEED OUT=RXNOUT RAFF  
  BLOCK TURBINE IN=RXNOUT OUT=RECYCLE  
  BLOCK COMPRECY IN=RECY1 OUT=RECY2  
  BLOCK SEPP IN=RECYCLE OUT=RECY1 FEEDCOL  
  BLOCK SPLIT IN=RECY2 OUT=RECY3 PURGECO2  
  BLOCK DISTILL IN=FEEDCOL OUT=TOPH2O BUTANOL  
PROPERTIES LK-PLOCK  
  PROPERTIES BWRS / COSMOSAC / NRTL / PENG-ROB / RK-ASPEN /  
  RK-SOAVE / RKSMHV2 / SR-POLAR / SRK / STEAMNBS /  
  UNIF-LL / WILS-RK  
PROP-DATA BWRKT-1  
  IN-UNITS MET PRESSURE=bar TEMPERATURE=C DELTA-T=C PDROP=bar &  
  INVERSE-PRES='1/bar'  
  PROP-LIST BWRKT  
  BPVAL CO2 WATER -.0795000000  
  BPVAL WATER CO2 -.0795000000  
PROP-DATA BWRKV-1  
  IN-UNITS MET PRESSURE=bar TEMPERATURE=C DELTA-T=C PDROP=bar &  
  INVERSE-PRES='1/bar'  
  PROP-LIST BWRKV  
  BPVAL CO2 WATER .0605100000  
  BPVAL WATER CO2 .0605100000  
PROP-DATA HOCETA-1  
  IN-UNITS MET PRESSURE=bar TEMPERATURE=C DELTA-T=C PDROP=bar &  
  INVERSE-PRES='1/bar'
```

PROP-LIST HOCETA  
 BPVAL CO2 CO2 .1600000000  
 BPVAL CO2 WATER .3000000000  
 BPVAL CO2 BUTANOL .3000000000  
 BPVAL WATER CO2 .3000000000  
 BPVAL WATER WATER 1.700000000  
 BPVAL WATER BUTANOL 1.550000000  
 BPVAL BUTANOL CO2 .3000000000  
 BPVAL BUTANOL WATER 1.550000000  
 BPVAL BUTANOL BUTANOL 2.200000000  
 PROP-DATA LKPKIJ-1  
 IN-UNITS MET PRESSURE=bar TEMPERATURE=C DELTA-T=C PDROP=bar &  
 INVERSE-PRES='1/bar'  
 PROP-LIST LKPKIJ  
 BPVAL CO2 WATER -.0633000000  
 BPVAL WATER CO2 -.0633000000  
 PROP-DATA NRTL-1  
 IN-UNITS MET PRESSURE=bar TEMPERATURE=C DELTA-T=C PDROP=bar &  
 INVERSE-PRES='1/bar'  
 PROP-LIST NRTL  
 BPVAL WATER BUTANOL 13.11020000 -3338.953600 .3000000000 &  
 0.0 0.0 0.0 19.17000000 117.6000000  
 BPVAL BUTANOL WATER -2.040500000 763.8692000 .3000000000 &  
 0.0 0.0 0.0 19.17000000 117.6000000  
 PROP-DATA PRKBV-1  
 IN-UNITS MET PRESSURE=bar TEMPERATURE=C DELTA-T=C PDROP=bar &  
 INVERSE-PRES='1/bar'  
 PROP-LIST PRKBV  
 BPVAL CO2 WATER .1200000000 0.0 0.0 -273.1500000 &  
 726.8500000  
 BPVAL WATER CO2 .1200000000 0.0 0.0 -273.1500000 &  
 726.8500000  
 PROP-DATA RKSKBV-1  
 IN-UNITS MET PRESSURE=bar TEMPERATURE=C DELTA-T=C PDROP=bar &  
 INVERSE-PRES='1/bar'  
 PROP-LIST RKSKBV  
 BPVAL CO2 WATER .0737000000 0.0 0.0 -273.1500000 &  
 726.8500000  
 BPVAL WATER CO2 .0737000000 0.0 0.0 -273.1500000 &  
 726.8500000  
 PROP-DATA WILSON-1  
 IN-UNITS MET PRESSURE=bar TEMPERATURE=C DELTA-T=C PDROP=bar &  
 INVERSE-PRES='1/bar'  
 PROP-LIST WILSON  
 BPVAL WATER BUTANOL .6102000000 -420.6027000 0.0 0.0 &  
 19.17000000 191.8000000 0.0  
 BPVAL BUTANOL WATER 2.450400000 -2492.023400 0.0 0.0 &  
 19.17000000 191.8000000 0.0  
 STREAM FEEDSTOC  
 SUBSTREAM MIXED TEMP=40.00000000 PRES=100.0000000 &  
 MASS-FLOW=2.210000000

MASS-FRAC WATER 0.885 / GLUCOSE 0.115  
 STREAM SCO2  
 SUBSTREAM MIXED TEMP=40. PRES=100. MASS-FLOW=0.089  
 MASS-FLOW CO2 1.  
 BLOCK SPLIT FSPLIT  
 FRAC PURGECO2 0.05  
 BLOCK SEPP SEP  
 PARAM MAXIT=50 TOL=0.001  
 FRAC STREAM=RECY1 SUBSTREAM=MIXED COMPS=CO2 FRACS=1.  
 BLOCK FEEDHX HEATER  
 PARAM TEMP=40.0000000 PRES=100.0000000 DPPARMOPT=NO  
 BLOCK DISTILL RADFRAC  
 PARAM NSTAGE=10 ALGORITHM=STANDARD MAXOL=25 DAMPING=NONE  
 COL-CONFIG CONDENSER=TOTAL  
 FEEDS FEEDCOL 2  
 PRODUCTS TOPH2O 1 L / BUTANOL 10 L  
 P-SPEC 1 50.  
 COL-SPECS MASS-D:F=0.7 QN=185.5 <kJ/hr>  
 BLOCK REACTOR RSTOIC  
 PARAM TEMP=40.0000000 PRES=100.0000000 MAXIT=100 TOL=0.001  
 STOIC 1 MIXED GLUCOSE -1. / CO2 2. / WATER 1. / &  
 BUTANOL 1.  
 CONV 1 MIXED GLUCOSE 1.  
 PROPERTIES SRK FREE-WATER=STEAM-TA SOLU-WATER=3 &  
 TRUE-COMPS=YES  
 BLOCK-OPTION FREE-WATER=YES  
 BLOCK COMPRECY COMPR  
 PARAM TYPE=ISENTROPIC PRES=100. SEFF=1. MEFF=1. NPHASE=2 &  
 SB-MAXIT=50 SB-TOL=0.0001  
 BLOCK-OPTION FREE-WATER=DIRTY  
 BLOCK TURBINE COMPR  
 PARAM TYPE=ISENTROPIC PRES=50. SEFF=1. MEFF=1. NPHASE=2 &  
 SB-MAXIT=100 SB-TOL=0.0001 MODEL-TYPE=TURBINE  
 PROPERTIES RK-SOAVE FREE-WATER=STEAM-TA SOLU-WATER=1 &  
 TRUE-COMPS=YES  
 BLOCK-OPTION RESTART=YES FREE-WATER=DIRTY FLASH-METHOD=GIBBS  
 EO-CONV-OPTI  
 SENSITIVITY S-1  
 DEFINE BUTANOL MASS-FRAC STREAM=BUTANOL SUBSTREAM=MIXED &  
 COMPONENT=BUTANOL  
 TABULATE 1 "BUTANOL"  
 VARY BLOCK-VAR BLOCK=DISTILL VARIABLE=NSTAGE SENTENCE=PARAM  
 RANGE LOWER="1" UPPER="15" INCR="0.5"  
 STREAM-REPOR MOLEFLOW MASSFLOW MASSFRAC  
 PROPERTY-REP PCES  
 ;  
 ;  
 ;  
 ;  
 ;  
 ;  
 ;  
 ;  
 ;  
 ;