



WORCESTER POLYTECHNIC INSTITUTE

INTERACTIVE QUALIFYING PROJECT

---

# Phobos First: A Mission to Settle Mars

---

*Authors:*  
Steven Kordell  
Daniel Fitzgerald  
Shawn Ferrini

*Date:* March 17, 2014  
*Adviser:* Prof. Wilkes  
*Sponsor:* The Mars Foundation  
*Consultant:* Bruce Mackenzie

# Abstract

With the likely next step in the exploration of space being a trip to the surface of Mars, it is important that all of the viable options on how to achieve this goal be considered. While some in the aerospace and scientific community believe that a direct mission to the Mars surface is the best option, the creation of an outpost on the Martian moon of Phobos as an intermediate step is also a possible solution. The purpose of this report is to provide an analysis the “Phobos Scenario,”.

Our tentative version of this mission proposal involves a five phase mission plan for the Mars settlement endeavor, the aim of which is to construct a base which can grow into a community on the surface of Mars. In our view the challenge of carrying out this initiative is as much political as a technological challenge. Hence, our goal was a technically feasible plan designed to minimize the risk to human life when the goal is a one way trips to Mars.

The socio-economic and political context is such that the settlers must not perish after arrival if the colonization effort is to continue. This means that the essential core of the base must exist before the first settlers arrive. Our scenario accomplishes this by first establishing a bare bones human outpost for a crew of 4 on the Martian Moon, Phobos, From there this skeleton crew would use a fleet of semi-autonomous, but in principle teleoperated, robots to remotely construct a base on Mars. They can teleoperate in real time from this vantage point.

The small advance crew would not be committed to a one way trip and could return to Earth after 12-15 months when Mars and Earth are again relatively close to each other. In our view, it is the one way trip to a hostile environment without a secure shelter and renewable food supply in place that makes Mars settlement politically controversial - even if the settlers are volunteers who know the risks and take them willingly. Should the first pioneers perish the whole endeavor would be put in political-economic jeopardy, so this risk must be minimized even if doing so increases the cost and complexity of the mission and modestly delays the arrival of humans on Mars.

# Contents

<b>Contents</b>	<b>2</b>
<b>List of Figures</b>	<b>4</b>
<b>1 Introduction</b>	<b>5</b>
<b>2 Background</b>	<b>8</b>
2.1 Past Work by the Mars Foundation . . . . .	10
2.2 Necessary Technologies . . . . .	12
2.2.1 3D Printing . . . . .	12
2.2.2 Robotics . . . . .	12
2.2.3 Agriculture . . . . .	15
2.2.4 Space Travel . . . . .	17
2.3 Social Challenges . . . . .	18
2.3.1 Public Perception . . . . .	18
2.3.2 Education, Interest, and Outreach . . . . .	18
2.3.3 Economics . . . . .	19
<b>3 The Phobos First Scenario</b>	<b>20</b>
3.1 Mission Phases . . . . .	22
3.1.1 Phase 1: Scouting . . . . .	23
3.1.1.1 Selecting the Mars Settlement Location . . . . .	23
3.1.1.2 Selecting the Outpost Location . . . . .	24
3.1.1.2.1 Martian Moons . . . . .	24
3.1.1.2.1.1 Phobos . . . . .	25
3.1.1.2.1.2 Deimos . . . . .	26
3.1.1.2.2 Possible Orbits . . . . .	27
3.1.1.2.2.1 Low . . . . .	27
3.1.1.2.2.2 High . . . . .	27
3.1.1.2.2.3 Synchronous . . . . .	27
3.1.1.2.2.4 Inclined . . . . .	28
3.1.1.2.2.5 Elliptical . . . . .	28
3.1.1.2.2.6 L1 Above Stickney . . . . .	28
3.1.2 Phase 2: Outpost Establishment . . . . .	28
3.1.2.1 Outpost Specifications . . . . .	29
3.1.2.2 The Modules . . . . .	30
3.1.2.3 The Tether . . . . .	32
3.1.2.4 Radiation Shielding . . . . .	33
3.1.3 Phase 3: Mars Surface Module Deployment and Installation . . . . .	34
3.1.4 Phase 4: Settlement . . . . .	35
3.1.5 Phase 5: Settlement Growth . . . . .	37
3.1.5.1 Incentive for Using In Situ Resources . . . . .	37
3.1.5.1.1 The Atmosphere of Mars . . . . .	38
3.1.5.1.2 Making Fuel on Mars . . . . .	39
3.1.5.1.2.1 Making Oxygen On Mars . . . . .	40
3.1.5.1.2.2 Making Plastics On Mars . . . . .	40
3.1.5.1.2.3 Energy . . . . .	40
3.1.5.1.2.4 The Need for Hydrogen . . . . .	40
3.2 Additional Mission Information . . . . .	41
3.2.1 Machines . . . . .	41

3.2.1.1	Robots . . . . .	41
3.2.1.2	3D printers . . . . .	42
3.2.2	Space Travel/Transportation Options . . . . .	42
3.2.2.1	Most Suitable Present Rocket Technology . . . . .	42
3.2.2.2	Dragon Capsule . . . . .	44
3.2.2.3	Technology appearing in the Next 20 Years . . . . .	45
3.2.2.3.1	Magnetoplasma Rockets and the VASIMR Engine . . . . .	45
3.2.2.4	Advanced Radiation Shielding . . . . .	46
<b>4</b>	<b>Findings</b>	<b>47</b>
4.1	STS Class Survey . . . . .	47
4.1.1	Experiment Overview . . . . .	47
4.1.2	Analysis of Data . . . . .	49
4.2	Presentation By Museum Group . . . . .	52
<b>5</b>	<b>Summary and Conclusion</b>	<b>57</b>
<b>6</b>	<b>Acknowledgements</b>	<b>58</b>
	<b>Bibliography</b>	<b>59</b>
<b>A</b>	<b>STS Documents, Surveys, and Analysis Results</b>	<b>62</b>

## List of Figures

1	Mars Foundation: Hillside Settlement . . . . .	13
2	Mars Foundation: Minimum One Way Settlement . . . . .	14
3	Phobotian Base: Artist's Rendition . . . . .	20
4	The Outpost on Phobos . . . . .	31
5	The Falcon 9 Fairing . . . . .	32
6	Results of the STS Class Survey: Scenario Likelihood . . . . .	53
7	Results of the STS Class Survey: Investment Value . . . . .	54
8	Results of the STS Class Survey: Required Technologies . . . . .	55
9	Results of the STS Class Survey: Appropriate Time Frame . . . . .	56

# 1 Introduction

The Apollo Program of 1962-72 demonstrated that space initiatives can be as effective in catalyzing rapid technological development as a war. In the case of Apollo, economic growth, and other societal benefits have been claimed but in fact the evidence suggests that space technology is relatively hard to transfer when fully developed. It is the underlying body of knowledge gained when stretching current capabilities that is fertile ground for other applications. The most interesting and credible claim for the Apollo program is that it stimulated a revolution in computing since this was needed as an enabling technology in a situation where cost was not a consideration as there was a political deadline to meet. The military had similar capabilities at the outset, but that technology was classified. Many civilian contractors got access to be best available and sought to improve that during Apollo. Later NASA nurtured the development of supercomputers due to its unique mission requirements.

Hence, one can reasonably claim that ambitious missions to space hold the potential for important scientific discoveries while their development spurs innovative engineering, spinoffs and completely new technologies. The question still at issue is whether the Apollo situation was unique or is a reasonable basis for estimating the likely impact of a program leading up to the settlement of Mars? Apollo was not designed to produce economic returns and neither would the settlement of Mars, at least in the short run. Both reaching to moon and Mars are the realization of an ancient dream- sort of a cultural quest - but one that has meaning for the whole human race. It is a step forward toward a destiny that reaches beyond the Earth and ensures the survival of the race even if Earth does not survive as an inhabitable planet. It is hard to put a price on the value of something like that. Only now, 50 years after Apollo do we know enough about the moon to make an economic case for a lunar base. Many think the learning curve for Mars will be faster and the case will come together sooner than that, but for now the case is that it can be done and many want to do it in this generation.

This seems to be the beginning of a new age of discovery and the social implications of the last one 600 years ago were vast since it indirectly led to the industrialization of Europe. This care technology shift changed the balance of wealth and political power among the nations of Earth. Backward European nations came to control regions in which the previously dominant agrarian empires flourished. This includes the Ottoman Empire in the Middle East, both the Muslim and Hindu controlled principalities of India and the British even made inroads into

mainland China, due to their control of the seas. Underlying this upheaval in the world order were European advancements in firearms and naval technology culminating in the use of ships as mobile platforms for cannons. Field artillery meant walled cities could be battered down from distance and local lords could no longer defy the will of the monarch, and so the nation state was created first in Europe rather than the Middle or Far East [31].

By analogy, what are the implications of a new age of discovery in space? Some visionaries claim that space exploration promises vast natural resources and its colonization represents a watershed advancement for the human species. The latter is probably a valid claim. The former is questionable. While not disagreeing in principle that over the long haul space resources will lead to space settlement, in the short run natural resources for use on Earth, rather than to be used in space to build infrastructure, are unlikely to come from space. The historical equivalent of spices, tea and silk with high value, but both compact and lightweight would be needed to justify an import from space to the Earth. Even platinum is probably not valuable enough to import from space. It would probably have to be something unobtainable on Earth at any price for a raw material to support trade with Earth.

Hence, one cannot justify Mars settlement in economic terms at this point, though in the future it will probably be a shipping center in an interplanetary civilization encompassing the solar system. Its plentiful carbon dioxide resources, essential to space agriculture, will probably make Mars a major center of economic activity when space is populated by humans and their essential plant partners in artificial biospheres. The ease of agriculture on Mars means that exotic foodstuffs and plant based manufactures and materials will probably come from Mars rather than the Earth. This is because its gravity well is substantially smaller than that of Earth, its main competitor, and Mars can produce its own rocket fuel in abundance to reach space with its specialized products.

For now, when space resources means something Earth needs that Mars has, the economic case based on resources in space cannot be made, It is easier to make such a case for the moon but even that is conditional on breakthroughs in nuclear fusion technology and a continuing energy crisis on Earth as the end of the oil era draws near. The case for Mars is scientific (i.e. what happened to the water and atmosphere that previously existed?) and the possibility of self sustaining settlements due to the relative ease of agriculture compared to the other planets in the solar system, in our view that is ample justification for planning a Mars settlement program.

A program on the scale of colonizing another planet implies many technological and economic challenges, and the risks involved are often cause for societal and social disapproval and political hesitance. Certainly casualty rates comparable to those Plymouth Plantation and Jamestown suffered in the 17<sup>th</sup> century colonizing the “new world” would not be acceptable today. Things looked different in the 17<sup>th</sup> century given that in the 14<sup>th</sup> century the Black Death in Europe carried off at least a third of the population, possibly half, and in some cities as many as 90% of the inhabitants died. It took 150 years for the population of Europe to recover [31].

Perceptions of acceptable risk are shaped by very different experiences today. In the terrorist attacks on the World Trade center during 9/11, NYC lost 2606 people out of a population of 8,300,000 and ground to a halt, traumatized. Elsewhere more people died bringing the US total for the day to 2996. The USA, with a population of 314,000,000, massively changed its way of life in response to what was considered heavy losses and high risk to the average citizen. However we lost 42,000 citizens to car accidents that same year. Risk perception is not based on statistics. The loss of the space shuttle Challenger and its crew of 7 volunteers, was considered a national disaster and shut down the US space program for 3 years. Had Apollo 13 not been brought home safely, the loss of 3 astronauts might well have ended that famous and highly successful space program. Thus, the perceived risk of a Mars settlement mission is a critical variable that must be addressed in the design of the mission. If it is not such, undertakings won't be seriously considered by governments, the public, or even the private sector, which tends to shy away from financial losses due to bad publicity [31].

Thus a vicious circle arises; space missions cannot be made feasible and risk cannot be minimized without sufficient investment in technological advancement, but investment funds will not be forthcoming until technological feasibility with acceptable risk can be estimated or demonstrated. The sponsors want minimum cost and minimum risk and the two are often incompatible. Yet investment funds have to come from somewhere.

Note that airplanes carried bombs and then the mail before they carried substantial numbers of passengers, but are now considered acceptably safe. They are demonstrably safer than automobiles, but are not generally perceived to be safer by the public. That may be because one loses over 100 helpless people at a time in a plane crash and it makes the news every time. Car accidents are only local news, unless a celebrity dies. Few people die in any one incident, though there are many incidents. There is also the question of who was at fault and whether



they were helpless victims worked into the perceived risk equation for automobiles.

Thus, a major concern in our space mission design was perceived risk and especially minimizing the number of helpless people at risk with no hope of rescue at the outset of the project when the risk of death due to equipment or system failure is at its greatest.

The Phobos-First Mars Colonization Feasibility Study Interactive Qualifying Project (IQP) is a paper research study on a specific hypothetical scenario for human colonization of the planet Mars and the challenges, implications, and significance thereof. The project investigates the prospect of a series of manned missions to the red planet via an intermediate outpost on its moon, Phobos. Research on all prominent details of this “Phobos Scenario” are presented, the technological, societal, and educational aspects discussed, and an outline of the case for the mission is placed in the context of foreseeable technological, economic, and social conditions. In addition to the final scenario proposal, accompanying presentations and educational material are produced in coordination with the Mars Foundation and a partner IQP team working on a public exhibit suitable for a science museum or discovery center that would depict this approach to the settlement of Mars at a level suitable for middle school students, their older siblings and parents.

## 2 Background

Multiple methodologies exist for establishing a permanent human settlement on Mars. One popular scenario advocated by the Mars Society is Robert Zubrin’s “Mars Direct” proposal for a manned Martian mission which involves starting with an unmanned mission to land equipment on Mars to process the atmosphere and/or ground water to create fuel for an Earth-return mission. Several months later, once there is a return mission fuel supply, a manned habitat module would follow and land at the same site. This would temporarily house the astronauts until their return trip several months, probably about a year, later [32]. NASA initially rejected the plan, but it remains a popular scenario today and many derivatives exist. In general this is considered a mission to explore Mars, not a first step in establishing a settlement.

Another plan which was designed for better economic, political, and technological feasibility, is known as the Footsteps to Mars scenario [12], which instead of having only two launches, breaks the Martian exploration mission into seven steps in an attempt to maximize the benefits

of the mission while minimizing economic and political issues which would cause the program to be cancelled early. “Each individual step must have a goal which can be defended not merely as a step towards Mars, but as a significant advancement in its own right.” This program, however, still has the major political flaw that it could and likely would be cancelled following a successful and historic landing on the planet. The original paper even emphasizes this point, “the lesson of Apollo, if you accomplish your goal, your budget will get cut.”

Therefore, if mankind wishes to colonize Mars and not just land on it, a new scenario is needed, one which is technologically sound and safe for those involved; yet has the benefits of the footsteps to Mars scenario, ensuring that each phase of the mission is a notable achievement in and of itself; but it must also create momentum and facilitate the next step. Ideally one wants to create the political and financial incentives to increase investment and reduce the probability that funding priorities will change and the program will be declared a success and cancelled once a manned Mars landing is accomplished, but well short of the real and intended goal of the whole initiative.

The Phobos scenario is designed to create a permanent human settlement on Mars, without having to endure the vicious cycle of space missions in which a mission could not be made feasible without sufficient investment, but investment is withheld or minimized until feasibility and acceptable risk can be demonstrated. When an economic case with built-in investment incentives are not in place, public support, political benefits and perceived scientific yield are weighed against cost and risk. In the case of Mars, reducing the cost means eliminating the return trip and this increases perceived risk as well as raising ethical issues. In effect, to sustain the effort it will have to be part theater in which the pioneers become celebrities on Earth and the general public can follow their experiences, celebrate their exploits, witness heroic efforts that end in failure and identify with their problems. I.e., they have to be viewed as something like a sports home team representing the nation and planet at an away game, though they will not be coming home for a victory parade if they succeed. The risk that this approach entails is that the the loss of any one of them is like a body blow to millions who identify with them, and that kind of failure carries huge social, political and economic costs that simply must be avoid or at least minimized to avoid the cancellation of the program.

The humans of the second mission in the Phobos Scenario would be permanent human settlers, unlikely to ever leave the surface of Mars again because of the energy necessary to escape

Martian gravity and the difficulty in making the necessary quantities of fuel while the base is still in its infancy. The mission is possible with only minute advancements in today's technology, not requiring advanced autonomous robotics tasked with preparing the surface dwellings (autonomy requires significant machine intelligence to carry out the tasks). Nor does one need new rocket support technologies capable of getting humans on or off the planet at the outset and after people arrive on the planet there is no need to get them off of it again quickly.

The Phobos scenario takes a more indirect route to the goal of colonizing Mars. Its first mission would be to land a small human crew in a temporary habitation in orbit around Mars. This could be an outpost on one of the Martian Moons, Phobos or Deimos, or an orbiting space station. From this location, in relative proximity to the future settlement on the Martian surface, the crew would oversee the construction of the Martian base in real-time by utilizing semi-autonomous or tele-operated robotics as well as 3d printers and various material fabrication techniques.

While preparing the infrastructure of the Martian base for the arrival of human settlers, the explorers on Phobos (or one of the other orbiting locations) could study both Mars and the Martian moons. A key advantage to the Phobos-First scenario is the possibility of recovering the Phobosian crew in the event of catastrophe whereas this is not an option for the humans who have chosen to go directly to Mars. This also results in a more thorough inspection of the Martian base and more opportunities for the Phobosian operators to discover flaws or errors which could be fatal to both the colony infrastructure and thus the people living there.

The construction of a Martian base through the Phobos-scenario involves utilizing advancements in many technologies which have recently experienced a surge in development, including 3d printing, robotics, agriculture, and space travel. There are also a great many contextual societal concerns which need addressing such as strategic positioning for potential long term economic advantages, political justification, public perceptions and support, and the scientific and educational value of the proposed program.

## **2.1 Past Work by the Mars Foundation**

The Mars Foundation primarily has two Mars settlement designs. The hillside scenario [20] and the minimum one-way scenario [14].

Hillside is part of the Mars Homestead Project which is intended "to design, fund, build and

operate the first permanent settlement on Mars” by identifying “the core technologies needed for an economical, growing Mars Base built primarily with local materials.” It provides a detailed plan for constructing a settlement on the Martian surface. Hillside is designed to initially house 12 people and provide them with everything they need to survive. It also provides the manufacturing capabilities to expand the base into a much larger Martian settlement over time. Construction of Hillside base is done after instantly deployed habitats have been delivered to the surface which will temporarily house the construction crew. This first crew will work to establish basic infrastructure such as water wells, gas plants, temporary construction facilities, and mining/refining/manufacturing operations. The base will then evolve into a permanent habitat with redundant power, food production, and life support systems. The base will continue to expand until it accommodates 100 people at which point it will be considered mature. Figure 1 shows an artist’s rendition of the base.

The minimum one-way base has a more modest or bare bones design philosophy. This settlement is designed to provide the minimum infrastructure needed for the survival of a permanent crew of two individuals, meeting the financial constraints of NASA’s proposed ‘flexible path’ policy. It also provides basic manufacturing abilities which allow the base to expand over time. Figure 2 shows an artist’s rendition of the base. In the case of the Phobos scenario, the team decided the simplicity of the minimum one way base makes it the optimal choice for this colonization plan and chose to devise the Phobos First plan around this base design concept, though possibly enlarging the first group of pioneers to land together. However, the nature of the Phobos scenario allows for a great deal of flexibility in the Mars base chosen for tele-operated construction. Since the base will be constructed and inspected in advance by semi-autonomous robots controlled by human beings, any base which allows humans to survive and thrive on Mars could be constructed without creating risk for the first colonists. It is just a matter of how many crews serving a year on Phobos will be needed to get it ready for occupation. This team thinks the minimum one way mission would require only one advance team and another one concurrent with the landing of the first settlers. Anything else might require considerably more lead time. Note that in any settlement base design, exploration and scientific investigation are merely secondary goals.

The important part of a Mars colonization mission is inherent to it. If the pioneers arrive alive, stay alive and hopefully thrive but make space for more settlers to join them, that is all

that is required. The settlement should grow but success is simply if one can expand life beyond the Earth. The settlers are not there to make a profit, plant a flag or do research other than that needed to allow them to learn how to thrive in this alien environment.

## **2.2 Necessary Technologies**

### **2.2.1 3D Printing**

3D printing is an additive, automated, digital manufacturing technology emerging to drastically change the way physical objects are constructed. It is poised to revolutionize many areas of manufacturing by offering several key advantages over normal methodologies. Among these are the ability to create designs of different complexities without sacrificing simplicity of process, low cost of customization, very high material efficiency, and rapid production times. More importantly, it may transform the feasibility of space habitation, allowing tools, materials, food, and perhaps entire habitable structures to be printed as-needed from in-situ materials.

Any construction done on the Martian surface will likely rely at least in part on 3D printing. In the Phobos scenario, the 3D printers on the Martian surface could be operated or monitored remotely by the humans living on Phobos. Robots on the Martian surface would maintain the 3D printers and use the products produced by the printers to construct the settlement. Using this method of fabrication, a Martian settlement is not limited to the materials brought directly from Earth. Rather, the base can be a combination of Earth-brought tools and depends heavily on In-Situ Martian materials.

### **2.2.2 Robotics**

Robotics is the study of programmable electromechanical systems capable of performing a large variety of tasks in the real world. New robotic technologies have the potential to drastically reduce the cost and risk of space exploration and colonization.

The exploration to locate materials, construction, and maintenance of a Martian settlement will almost certainly require the use of robots in some form. In the Phobos scenario, after a human crew arrives in orbit around Mars, they would proceed to deploy a relatively small robotic workforce accompanied by 3D printers and some material fabrication tools. Residing relatively close to the construction site, humans could operate the robots remotely in real time to gather or salvage resources, expand the workforce, and construct the minimum Martian base.

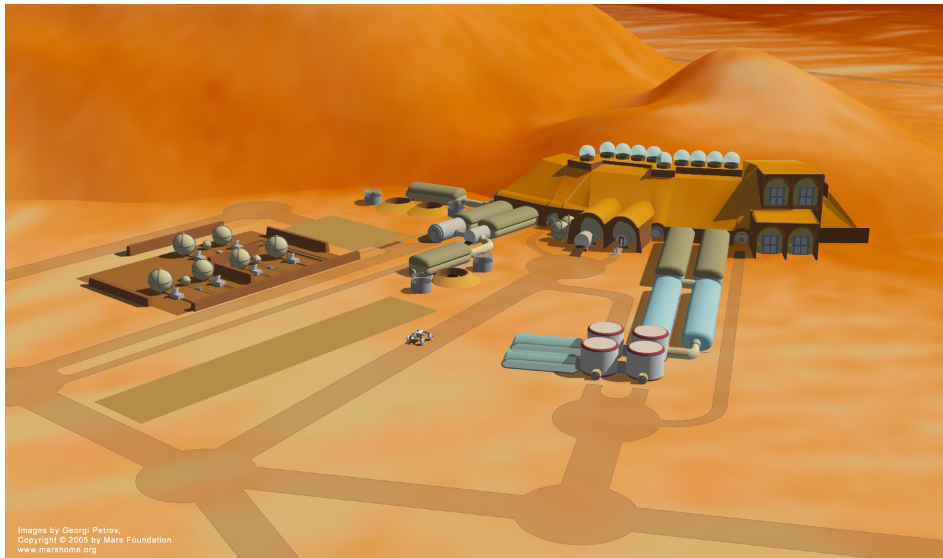

(a)

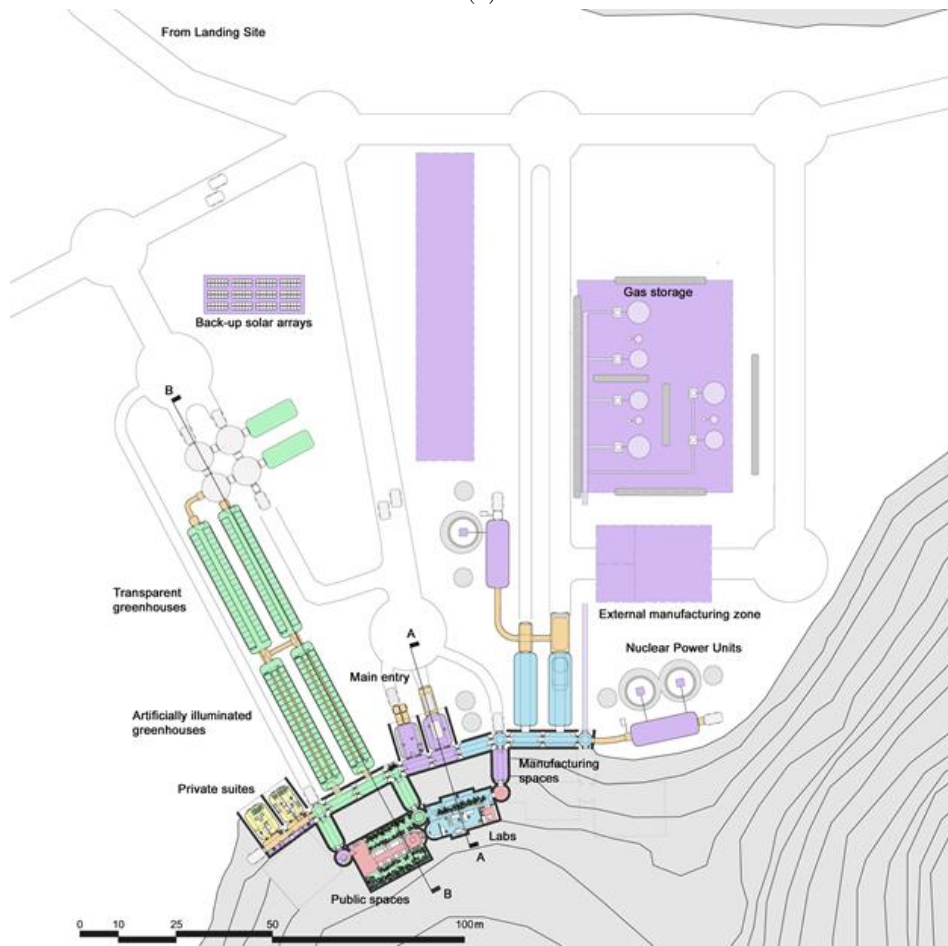

(b)

Figure 1: Mars Foundation: Hillside Settlement

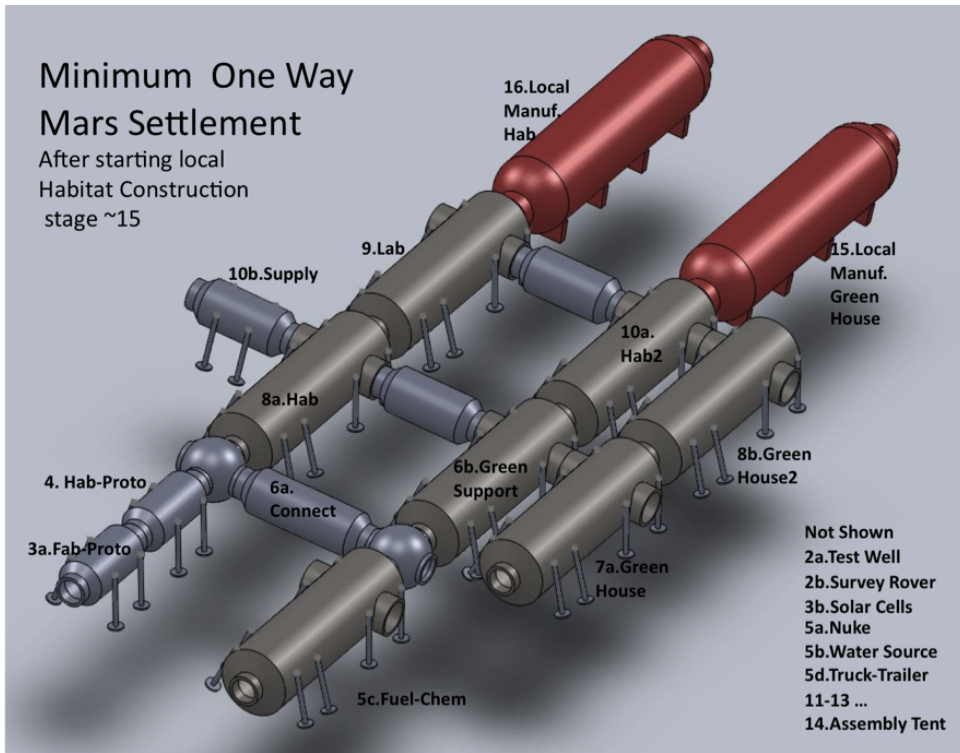

(a) Initial Settlement

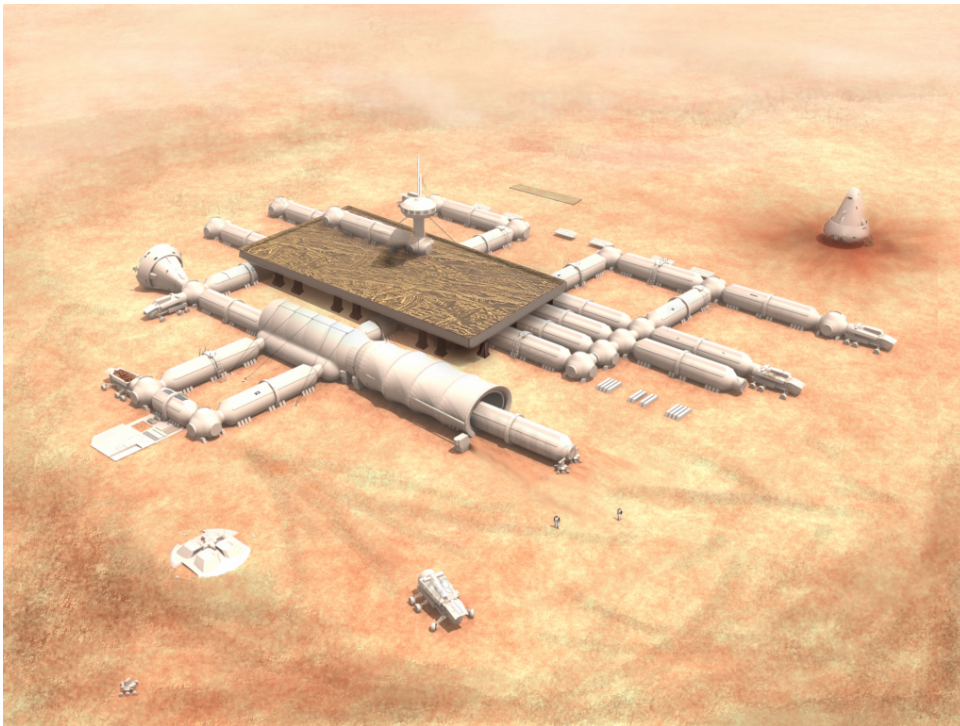

(b) Settlement Growth and Expansion

Figure 2: Mars Foundation: Minimum One Way Settlement

The robots would work to harvest the natural resources on the Martian surface or in the Martian atmosphere, synthesize these resources into usable product, then assemble or 3D print the product as necessary to construct more robots, 3D printers, and fabrication tools, using at least 90% local materials, and increasing the size of the available semi-autonomous robotic labor force. The larger Mars labor force working under the direction of the humans in Martian orbit would then fabricate fiberglass tubes, partition and configure the interiors and then join them to assemble the Martian base unit by unit, some of them being specialized workplaces and others generic. When the base is suitable for the arrival of permanent human settlers, either the orbiting humans, or perhaps a fresh crew delivered from earth, will land on the planet and begin their new life on the Martian colony. The long term effects of micro gravity on the human body would probably make it advisable to send the first crew home to recover for a few years. Broken bones and pulled muscles on arrival would get the settlement off to a troubled start with accompanying bad publicity.

### **2.2.3 Agriculture**

A paramount concern when discussing Martian settlement is agricultural production. With the Phobos-scenario, by the time humans land on Mars, all necessary agricultural systems should have been fully constructed and prepared by the aforementioned robotic labor force and should be at some degree of readiness, probably already producing a steady supply of food and other raw materials. Aside from the production of food, part of the agricultural system will be set aside for the production of other, more multi-purpose, vegetation such as sunflowers for the protein rich seeds and the latex from the leaves to produce rubber. Other non foodstuffs would be grown to produce medicine, rubber, glue, resins lubricants, fibers for textiles, paper, baskets, rope, wicker for furniture probably made from multipurpose bamboo and the like. Plastics can be made starting with carbon in the atmosphere without the use of vegetable feed stocks, but nylon and rayon probably cannot and plastic rope is inferior to hemp or nylon rope. Vegetable debris would be used to produce soil via compost with the aid of earthworms brought from Earth. There is some evidence that one can grow several Earth plants, especially rye, in simulated Martian regolith but it is not rich in organics like Earth soil so most will not thrive without compost being created from plants grown using Martian carbon dioxide and water. Hydroponics may not be necessary on Mars but probably will be on the moon.



*Ecologist Wieger Wamelink of the Dutch research institute Alterra of Wageningen University was interviewed by Jesse Wieten in The Hague (XNA) on Jan 21, 2014. He reported an investigation of whether it is possible to grow different types of plants in the soil of Mars and on the moon. They did an experiment with 14 plant species on artificial Martian and lunar soil, provided by NASA. The experiment lasted 50 days.*

*"The [Martian] outcome was quite a big surprise," said Wamelink. "Some species such as rye and cress were already sprouting within 24 hours. Eventually plants on Mars soil were even blossoming. We fertilized them with a brush, with some even seeding. It was exciting to watch. Tomato plants were growing and carrot plants even had small carrots, cress formed seeds."*

The crew on Phobos will also need food during their stay. Since their habitation is only temporary and it will be possible to exchange the crew multiple times during the period of settlement construction, the Phobotian crew might simply bring enough food with them to last the entire duration of their mission, or their temporary habitat could have its own greenhouse for food production of at least salad, fruit and fresh vegetables. The luxury of a fish pond will probably have to be deferred until people land on Mars and have ample supplies of water, but fish and worms are often part of a closed loop biosphere.

While food and building materials are necessary for the success of any long-term space endeavor, something equally, if not more, important is oxygen. The atmosphere of Mars is mostly carbon dioxide with very little oxygen. While humans cannot breath carbon dioxide directly it can be processed to extract the oxygen and the derivative carbon will be very useful. Plants evolved under conditions in which the carbon dioxide was a much higher proportion on the atmosphere than it is currently. In the Mesozoic Era (Jurassic, Triassic and Cretaceous) it was about 3000 ppm compared to 397ppm today and about 300 PPM in the recent past. It was closer to 200ppm before the industrial revolution and the widespread burning of coal and oil for energy. So about ten times normal Earth levels today might be ideal for the C3 type photosynthesis plants that existed then. The more recently evolved C4 photosynthesis plants thrive under conditions more like the Earth recently and even today.

Most of the eleven well known staples are the C3 type, the exceptions being maize (corn) and sorghum, which are C4 plants. Hence, even the useful staple plants such as rice and soybeans,

which are adapted to higher carbon dioxide levels, would not be likely to thrive outside of a controlled atmosphere greenhouse. Still, C3 plants can take high carbon dioxide atmosphere and enrich it with oxygen to levels appropriate for humans and C4 plants, about 21% oxygen. The greater problem for habitat and especially greenhouse atmospheres is that Earth atmosphere is about 78% nitrogen, and nitrogen is relatively scarce on Mars. At least the nitrogen fixing legume plants (like peanuts) that take in nitrogen and produce nitrates and nitrites to enrich the soil for all plants will need Earth like air in their portion of the greenhouse. While not abundant, there is nitrogen on Mars, unlike the moon which has little to none and will have to import it.

#### **2.2.4 Space Travel**

The technological difficulties associated with the launching of goods into space affordably can be overcome best by avoiding the necessity of the trip. When this is not an option, the next best solution is to reduce the weight of the cargo as much as possible or avoid launching from locations with large gravity wells.

Robotics and 3D printers provide one means of reducing both the necessity of the trip and the weight of the cargo. Two ways of significantly reduce the amount of cargo which needs to be moved as well as the number of trips and ships needed to carry it are 1) By finding materials on-location and assembling them into useful components; and 2) Growing ones own food in the native environment from seeds and cuttings rather than hauling concentrated foodstuffs which cannot expand their supply over time across space. The Phobos-scenario also makes Earth return trips easier as there is a massively smaller amount of gravity being fought a spaceship seeking to reach orbital velocity.

Still, there are many other technical questions which require answers for the successful settlement of Mars. Primary among them is the question of how to bring the temporary Phobos living quarters from Earth to the Martian moon as a unit lifted from the Earth in sections and assembled in orbit or assembled and then lifted off of the moon. The Phobotian explorers will likely be uncomfortable in very confined quarters as they work to construct the Martian base. On top of this, while unmanned craft have successfully made the trip to Mars carrying rovers for preliminary exploration, carrying human cargo requires additional resources, such as life-support and waste disposal which complicate matters. The additional resources as well as living space necessitate an increase in the amount of fuel carried or technologies which use the fuel more

efficiently. It is not clear whether the fuel will have to be lifted from Earth, the moon or be gathered from Earth Atmosphere in space. For simplicity we will assume the existence of a fuel depot in orbit around the Earth at a suitable departure point for Mars when Earth and Mars are approaching their closest point in a year.

## **2.3 Social Challenges**

### **2.3.1 Public Perception**

Public backing and hopefully enthusiasm is (presumably) requisite for any large-scale space mission. For government programs, public support justifies the budget designated for the program. For commercial programs, public interest is a direct source of revenue, as observed in the recent success of the Mars One recruiting program. For private programs, such as SpaceX, public enthusiasm helps the company to gain recognition and to recruit the most talented employees. However, successful missions must be favorably (and hopefully accurately) perceived by the public. One of the largest traditional impediments to the formulation of a manned mission to Mars is not technological per-se, but social and psychological; public aversion to the human jeopardy inherent to space missions and unrecognized value of potential large returns over time to justify the large cost. The less risky and expensive a proposed space mission is, the more likely it will be to gain public support.

### **2.3.2 Education, Interest, and Outreach**

The Apollo missions helped inspire a generation of scientists and engineers, who in turn helped develop the next generation of space technology. Space missions benefit from a well-educated, scientifically literate public, but well informed people can legitimately disagree and right now addressing environmental concerns has more public and political support than the space program. On the other hand, the space program is not doing anything new and exciting. Just as a literate public is more likely to be able to enter the debate and hopefully understand the case for Mars settlement, the reverse is also true, since space program technologies have been a potent catalyst for STEM education in the past. Further, space exploration is not delivering the gloomy dismal message that the future will be less resource rich and prosperous than the past and asserting the limits to growth. The message of the space program is that the sky is not the limit and a new era of exploration and pioneering is beginning.

With the continuous raising and education of the general public comes a better understanding of the benefits and risks associated with space travel and all such related high technology endeavors. Through increased general knowledge, the public can make more informed decisions on matters relating to the undertaking of space exploration and settlement. The issues are now more about letting people who want to pioneer and be entrepreneurial in risky ways, do so and profit from it if they can. Thus, some new laws need to be passed. Public support will be even more critical if tax monies are to be used to develop Mars as a government policy and project.

### **2.3.3 Economics**

Astrophysicist Neil deGrass Tyson identifies only three facets of human society capable of moving our species to undertake momentous endeavors: religion, war, and economic returns. Religion has mostly lost relevance as a motivating factor in the modern world. War is usually risky, wasteful, and undesirable, he concludes. Thus, he that the pursuit for economic returns is the only viable force powerful enough to move our society towards the exploration and colonization of Mars and space. As such, for any Mars colonization proposal to be realistically feasible, it must include a mechanism to generate enormous economic returns, and a profit making system must be central to the plan. As noted earlier, this is a problem if one looks at only the short run economics, it is hard to make the economic case for Mars but it is transformative in the long run.

### 3 The Phobos First Scenario

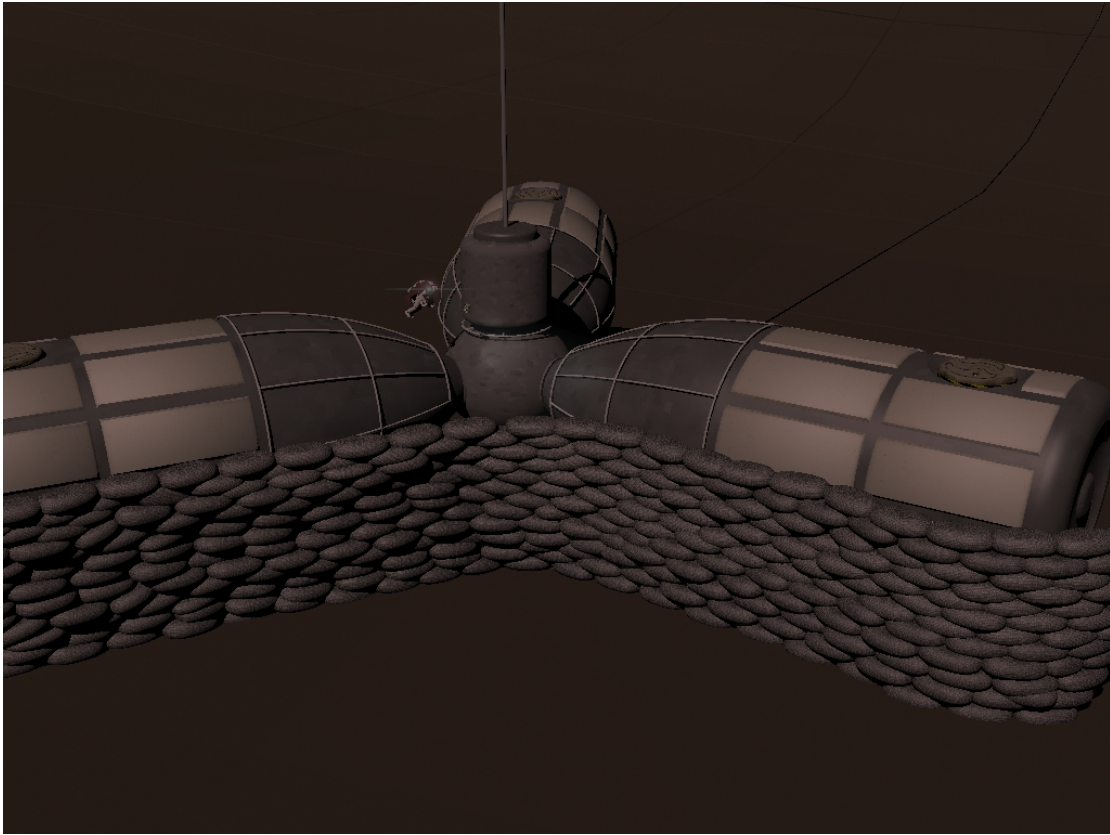

Figure 3: Phobotian Base: Artist's Rendition

Establishing a permanent human settlement on Mars is an important step in mankind's goal of expanding life beyond the planet Earth. Many mission scenarios have been proposed to realize this goal but the initiative has not gotten under way in part for lack of consensus on how to proceed. Further the boosters do not assess risk the way the general public does. Many mission proposals are not feasible on an acceptable time frame with today's technology as they require advanced robotics, rocketry, or entail great risk to human life. As noted earlier, the idea of one way trips is so controversial as to be a pivotal issue in evaluating a proposal and yet settlement programs like other migrations do involve permanent relocations.

Phobos First (also called the Phobos Scenario) is a plan to establish a Martian colony while also minimizing the risks of the colonization process and using only technology that is either available now, or will likely be feasible within the next decade. The Phobos scenario does this by breaking the settlement process into smaller steps, each of which is a gradual but important

advancement in and of itself, but when combined, results in a thriving human colony on another planet, capable of supporting itself and expanding through in-situ resource utilization.

One can assume the construction of a permanent Martian settlement will require advanced robotics to build the settlement, unless the settlement is transported from Earth in a large pieces that connect., which has its own challenges. Though the outlook for technologies like fully autonomous robotics and artificial intelligence looks very promising during this century, whether it should occur and when it would occur are both matters of debate. Hence, we will assume it does not happen in the next ten years. Depending on them for future near-term missions would be risky. To get around this hurdle, only tele-operated robots with some autonomy should be expected to be available in time for the proposed settlement construction mission. In the construction of such a large and intricate structure via ISRU, controlling these robots from Earth would be extremely difficult, tedious and time consuming so in effect one would end up waiting for the next generation of more capable technology anyway. This is due to the time it takes for radio signals to traverse the interplanetary distance. To overcome this hurdle, the Phobos scenario entails constructing an orbital outpost on the Martian moon, Phobos at the outset. A human crew working from the outpost would then tele-operate robots working on the surface of the planet Mars in real time to construct the settlement for a future group of humans to inhabit.

A large benefit to this design is the relatively minimal risk to human life over the course of the mission. The humans on Phobos will be able to escape the gravity of the moon with relative ease when they wish or need to return to Earth, Humans placed on Mars, would be unable to do that unless the Mars Direct strategy was put in place to overcome the large gravity well. Since the settlers do not intend to return to Earth, that up-front insurance policy investment would be harder to justify than an interim base. The problem is temporary in any case since rocket fuel production will be part of the completed base infrastructure. Our scenario avoids this vulnerable period since no one lands on the planet until the settlement is operational and has been thoroughly inspected from the outpost. If any one-part of the mission goes badly, there are opportunities to recover and ensure that the full mission is successful. Since the mission duration is spread out over two decades, no large upfront investment other than landing the expendable Phobos base is necessary and equipment for future stages of the mission can be thoroughly tested and redesigned if necessary before it needs to be used. The mission could be

done with technology only slightly more advanced than today's, but advances in technology over the mission duration will hasten the completion of the settlement and facilitate its expansion.

### 3.1 Mission Phases

The entire mission begins with the launching of satellites to inspect both Phobos and the Martian landing sites from above. Rovers will follow shortly thereafter for further surveying. Once the landing sites are selected and confirmed, the unmanned Phobos outpost will land and install itself on Phobos. At the same time, a prototype water well will land at the Martian settlement site and try to dig a small prototype well to ensure water is accessible to the future colonists. After the test well is completed, prototype habitation and fabrication modules will land at the settlement site on Mars to ensure the module designs hold up and that the design standards were sufficient to survive under the prevailing conditions. When the designs are finalized and constructed, the modules will be launched and land on Mars shortly after the first Phobotian crew occupies the outpost. After a maximum of nineteen months of remote assembly later, the first Phobotian crew will depart. The second Phobotian crew along with the first few permanent Mars settlers will arrive six months later. Two months after that, the second greenhouse, second habitation module, and extra supplies will land with the settlers. The second Phobos crew will leave a maximum of seventeen months later and will arrive back on earth eight months after that. Only at that point will the settlers be left to fend for themselves with support from Earth. Waves of settlers will be arriving as the base expands to accommodate them. This process is ongoing and concludes the settlement startup mission. From this point forward, the settlers will work to expand the Martian base using in-situ resources and 3d-printers. More settlers arrive from Earth as space becomes available. Additional settlements can be started by the settlers but another crew could also go to the Phobos outpost to start other bases remote from the original site to the point that small crews can live in and work on them simultaneously. The Phobos outpost might not be manned again but could still be used as an evacuation point, or as an orbiting research station, much like the international space station around Earth. We like the idea of continuing to use it to start up bases on the Martian surface, to increase the return on investment.

### 3.1.1 Phase 1: Scouting

The scouting Phase of the Phobos First scenario requires the selection of two sites: a location on Mars for the permanent human settlers, and a location somewhere in orbit for the outpost. The selection of these locations will be done first from orbit using satellites to collect information about the geology of potential sites followed by rovers to better inspect candidate locations.

**3.1.1.1 Selecting the Mars Settlement Location** A number of satellites are already exploring Mars from orbit and information from these will be useful in selecting the sites for the first bases. It may be necessary to launch additional satellites to Mars to ensure proper conditions are found. Once a site is selected from orbit, robotic rovers will need to descend to the planet to further confirm the chosen site is appropriate for the mission and contains the necessary resources for human survival and future base expansion. Unlike the majority of Martian missions, the location for the permanent human settlement will not be chosen for scientific purposes, but rather for its abundance of useful resources.

Among the most important resources needed by the settlers will be water. It will be needed for the crew's survival, for watering plants, for making hydrogen with a byproduct of oxygen (rocket fuel) , and for a range of manufacturing processes as the permanent base grows. As such, before undertaking the expenses associated with the construction of a complete Martian base, the availability of water must be confirmed. Thus, following the exploratory rover(s), a prototype water well would be delivered to the candidate site as a final confirmation step. In addition to this, prototype unmanned habitation and fabrication modules could be landed at or near the site. By monitoring the condition of these modules as the weather changes and sandstorms hit them, engineers back on Earth will have an opportunity to make changes in the designs of the final modules to be fabricated on Mars. The changes have only to be programmed and transmitted to the robots and 3D printers from Earth. The flexibility and ability to learn from experience improves the likelihood of a successful mission.

There are a number of possible locations for the Martian Settlement. One potential location would be the Hellas Planitia, a crater located at 70.0 E. 42.7 S. It's 7,152 m deep and 2300 km wide. The northeastern rim of the Hellas Planitia shows evidence of having plentiful ice deposits, with glaciers as thick as 500 meters [11]. Plentiful water from this ice deposit could be of great use to the settlers. Alternatively, the South Pole of Mars is believed to have a tremendous



amount of frozen water. There is estimated to be enough that if melted, could cover the entire planet in an ocean 11 meters deep [3]. There is also likely to be deposits of dry ice due to the amount of carbon dioxide in the atmosphere.

Any satellites and rovers used during the scouting missions can be used later for the gathering of scientific data once their primary objective is complete. Satellites in orbit could also be used for remote communication purposes, as the construction crew on the outpost will certainly require some. This dual purpose equipment should make it easier to secure funding for the mission.

The Martian settlement itself should also probably be placed a small distance from the planned landing location of the settlement modules, construction machines, and future settlers serving also as the crew of the base. This site must be close enough to the settlement site that extreme distances will not need to be traversed overland, but must also be far enough away that should catastrophe occur and the landing vehicle malfunctions, the settlement and any occupants living there will not be harmed. Additionally, the chosen landing site should not interfere with the settlement's ability to grow and expand in the future.

It would also be wise to choose backup landing sites and an evacuation take-off site in advance. Should an attempted landing fail catastrophically and the original landing site be damaged to much to use, it will be important that additional landing locations are available. One incident must not be allowed to threaten the integrity of the entire project. The evacuation take-off site is unlikely to be utilized until the base has reached an advanced stage of development, for only then will there be enough fuel to actually escape Martian gravity. Still, the option should be available with a crew-sized spacecraft in place. The craft may head towards Earth, the outpost, or to a different portion a Martian settlement located elsewhere on the planet if the base on the surface must be evacuated.

**3.1.1.2 Selecting the Outpost Location** The Phobos First scenario calls for the use of an orbital outpost to teleoperate the construction robots on Mars. The control outpost could be located in several possible locations including a Martian Moon, Phobos or Deimos, or in a number of different Martian orbits. Each location has various benefits and detriments which are described below. Phobos is currently seen as the best candidate.

**3.1.1.2.1 Martian Moons** The Martian moons may have resources which could be utilized in some way, however, it is unlikely that goods or crew will be transported from the outpost

to Mars or and vice-versa transport would be mainly to keep it stocked with supplies in the case of an evacuation. Instead, the outpost will serve only as a control post for the construction of the base, as an emergency escape route or scientific observatory after the completion of the construction mission. This strategy might be reconsidered if a resource of particular value is found on one of the Martian Moons which may make building or surviving on Mars easier. This value would have to be higher than the cost of the rocket and fuel needed to land the resource on Mars. This would only work in one direction. The Martian gravity well would likely make it too difficult for an early settlement to move resources from the Martian base to the outpost, though a more advanced colony might be able to make enough fuel from in-situ resources to make the trip possible. Since oxygen could be extracted from the upper atmosphere or the regolith of either moon at a later date, the outpost could also be expanded to an oxygen production or LOX storage facility, producing oxygen to replenish orbiting fuel depots designed to fuel spacecraft for trips further into the solar system or back to Earth. The carbon byproduct of atmospheric oxygen gathering would be a prized export to Earth's moon where carbon dioxide is in short supply but oxygen is not.. Additionally, an outpost on a Martian Moon could help move research forward in asteroid mining as the composition of the moons are expected to be similar to that of an asteroid.

Since there have been no rovers or landers on any Martian moons, little is known of their composition and available resources (In July 1988, two soviet probes were launched in an attempt to get a closer look at Phobos. Both were lost, though one did manage to take a few photos before vanishing). A satellite and follow-up rover will be needed to determine precisely where the outpost will be placed and to survey the moon to determine if any useful minerals are present.

A base on either Martian moon provides the benefit of reducing the effective dosage of cosmic rays the crew would be exposed to on the order of 150-300 mSv, as compared to staying on a space station in high Mars orbit [7].

**3.1.1.2.1.1 Phobos** Phobos is the largest moon of Mars with an average radius of 11.1 km and a mass of  $1.072 \times 10^{16}$  kg. It is in a tidally locked about 6,000 km from the Martian surface (9,400 km from the Martian center) and orbits the planet every 7.653 hours. Close to the surface, it would be easy to take high resolution images of Mars and less energy would be needed for radio transmissions. Being close also means the moon cannot be seen on Mars

south of  $69.8^{\circ}S$  or north of  $69.8^{\circ}N$  [7]. As such, it would be impossible to communicate with construction equipment at high Martian latitudes without communication satellites to relay the signals. Phobos is still visible from the Hellas Planitia, so a settlement based there could still utilize an outpost on Phobos, but direct line of site would not be possible throughout the entire day. There will likely be communication satellites in orbit during a mission of this scale anyhow, so this is unlikely to be a large issue. When line of site is available, it would take approximately 20 ms for radio signals to transmit from Phobos to the surface of Mars. For reference, a human eye blink takes between 100 and 400 ms.

Phobos has a particularly large crater known as Stickney, which has a diameter of about 9km and sits on the moon's face, always facing Mars, making radio communication to the planet easier. This crater might be a good place for the outpost, as its rim could create extra radiation shielding. A fine powder about a meter deep covers the entire surface of the moon, and could also be useful in shielding the outpost from radiation. Stickney crater sits 2.5 km below a Phobotian Lagrange point and is on the Mars facing side of the tidally locked moon.

Being below the synchronous orbit radius, Phobos moves around Mars faster than the planet itself rotates. This low energy orbit means a delta-V 400 m/s higher than that needed to land on Deimos from Earth would be needed [7]. Acceleration due to gravity on Phobos is about  $0.0058 m/s^2$ . An object dropped from waist high (1 m.) would take 18.6 seconds to fall to the ground. Such low gravity is unlikely to prevent the muscles of the human body from atrophying so crew members would likely return to Earth unable to walk, since this is akin to the microgravity on the ISS. After 6 months deployments to the ISS few astronauts can stand up in Earth gravity and it takes 1-2 years to recover.

**3.1.1.2.1.2 Deimos** Deimos is the smaller of the Martian moons, with an average radius of 6.2 km and a mass of  $1.48 \times 10^{15}$  kg. It is tidally locked in orbit about 23,460 km from Mars and orbits the planet every 30.29 hours. Being further from Mars, Deimos has better radio coverage of higher Martian latitudes, but the time of flight for radio signals to Mars is about four times longer at about 78.3 ms, though this is still not an appreciably long time and would not likely hinder the ability to tele-operate robots on the surface. Being in a higher energy orbit means less delta-V is needed for missions to or from Earth as compared to an orbit like that of Phobos. Gravity on Deimos is similar to that of Phobos with an acceleration due to gravity of

about  $0.0025 \text{ m/s}^2$ .

**3.1.1.2.2 Possible Orbits** Though there are many benefits to constructing an outpost on a Martian moon such as the availability of radiation shielding or harvest-able resources, it might be easier and more beneficial to simply build the Martian outpost in the form of an orbiting space station, allowing mission designers to choose the orbital characteristics best suited to the mission. To shield the station from radiation, one could pick up regolith from a moon, though this adds complexity to the mission design. Artificial gravity could be created by spinning the station, though this adds some complexity to the design as a de-spun platform would be necessary to position solar panels, radio antennas, and cameras.

**3.1.1.2.2.1 Low** One of the many possible orbits the space station could rest in is a low Martian orbit, an orbit below the synchronous orbit, similar to the one Phobos is in. Like Phobos, the outpost would circle Mars faster than the planet itself rotates. The only benefit this orbit has is that it has some flexibility in exactly how high the orbit is and the timing of the orbit as well as the other benefits that could come with a space station. It doesn't seem these benefits would be worth the loss of the radiation shielding provided by an outpost on Phobos. Perhaps collecting regolith for shielding would be an option in this orbit, but even then, it would likely be easier to simply place the outpost on Phobos.

**3.1.1.2.2.2 High** Another possible orbit for the outpost is a high Martian orbit, an orbit above the synchronous orbit, similar to that of Deimos. Like the low orbit, the high orbit doesn't offer too many benefits over that of a Deimos outpost. There is the benefit of an even lower delta-v to enter and exit such an orbit from Earth. Also, a relatively small delta-v could be used to drop a ship directly from the outpost onto Mars.

**3.1.1.2.2.3 Synchronous** The largest benefit of a synchronous orbit is that the orbital outpost could be positioned directly above the longitude line of the Martian Settlement, ensuring continuous line of sight communication with the base. This avoids the need for communication satellites and their associated radio delay. The largest downside is the same as with the other orbits, you would need to either bring your own radiation shielding, or harvest it from a nearby moon. Signal time of flight for one-way communication from synchronous orbit is approximately

56.71 ms.

**3.1.1.2.2.4 Inclined** An inclined orbit would allow you to pass directly over the Martian settlement on some orbits, limiting radio signal scattering caused by the angles of incidence which an equatorial orbit would have to deal with. On the downside, like all the outpost positions except the synchronous orbit, you would only have direct line of site for a certain period of time each rotation. Additionally, getting into the inclined orbit could be difficult and the inclination would precess, meaning you would not be directly over the base on every pass, but you would likely be close.

**3.1.1.2.2.5 Elliptical** The largest benefit of an elliptical orbit is that there is a period of time each orbit when very little delta-v would be necessary to escape orbit towards Earth, or to get into the correct orbit from Earth. On the downside, you'd only be close to the Mars for short period of the entire orbit cycle, and you'd be traveling at the fastest speed during this time. You'd also have to time this with the rotation of the planet if you wish to have line of site communication, which might only be possible on certain orbital multiples.

**3.1.1.2.2.6 L1 Above Stickney** About 2.5 km above the Stickney Crater on Phobos is a Lagrange point where an orbital outpost could sit in a stable orbit around Mars. A major benefit of this orbit is that you get some radiation shielding from the moon without the complexity of actually having to land on it. On the downside, you will be a little closer to Mars than Phobos, meaning your communication potential at high latitudes would degrade even further. Additionally, note that L1 is technically not stable, a craft placed there would slowly drift away, but very little fuel would be needed to keep the craft there.

This L1 point could also make a convenient parking spot for a spacecraft. After parking the craft, the crew could descend down to and dock with a Phobotian outpost in a capsule (or travel down a tether), returning to the vehicle when it is time to depart, avoiding the need of landing the entire ship on the surface of the moon.

### **3.1.2 Phase 2: Outpost Establishment**

The Phobos outpost will serve as the local manned base of operations for the construction of the Mars surface settlement and also for human exploration of Phobos, and remote controlled

exploration of Deimos, other locations on the surface of Mars, and possibly some asteroids. The outpost will be required to perform two primary functions: First, to keep its occupants, the Phobos crews, alive in a hostile environment further from Earth than mankind has ever ventured before. Such a feat would mark a huge victory in manned space flight by itself, with great knowledge gained. It would be an important step towards Mars settlement but safer, easier, and cheaper to perform due to its more temporary nature and the lack of a large gravity well to escape from. Second, the Phobos outpost must function as a remote command station for the tele-operated robots and equipment on the Martian surface during the construction, setup, testing, and initial habitation phases of the Mars settlement. Additionally, because the Phobos crews must at some point arrive and depart from the outpost, it must have easily accessible docking capability.

The Phobos outpost will be an assembly of modules sent directly from Earth that must rendezvous with Phobos, land on the surface, and automatically perform any setup and self-testing necessary to ensure its readiness as a human habitat and base of operations. The entire outpost would most likely be assembled in Low Earth Orbit (LEO) after being launched there by multiple Falcon Heavy rockets, it could then be transported as one unit to Phobos. The descent of the outpost to the moon's surface will also function to setup an elevator/tether system; this will be achieved by simultaneously dropping the outpost to the surface and extending the counterweight towards Mars with the tether unreeling between the two. The automatic setup processes will include revving up the nuclear power system, initializing life support systems, aligning communication antennas, deploying backup solar panels, and environmental monitoring. However, the most important and complicated part of the setup of the Phobos outpost will be in the establishment of protective regolith shielding.

**3.1.2.1 Outpost Specifications** The life support requirements of the International Space Station (ISS) can be used as a model for the life support needs of the Phobotian crew (assumed to be about four people). The ISS is supplied every year with about one ton of food and four tons of other household goods [5]. Equivalent or greater quantities will be needed for each crew of the Phobos outpost. The Phobotian outpost will need to be able to recycle water and air and store waste products. Methods of doing this can also be copied from the ISS, though waste will probably be stored instead of jettisoned. There will need to be room for sleeping, energy

production, life support units, living quarters, and the tele-operation control center. Energy will likely come in the form of either Nuclear Power or Solar Collection. Communication antennas, solar arrays, radiation shielding, and docking mechanisms will be needed outside of the outpost.

The Phobotian outpost will consist of three bullet-shaped modules, shaped to allow for maximum efficiency when transported in the launch fairing, with dimensions slightly smaller than those of the fairing's outer dimensions. The three modules will be arranged around a circular center hub, each one hundred and twenty degrees apart from the other, with the center hub being attached to a tether. Separate from the base and hidden behind a shadow shield for protection, is a nuclear reactor. The reactor will power all electrical systems related to outpost operation and will be backed up by solar arrays attached to the counterweight end of the tether/elevator. After the outpost has been successfully installed on the surface of Phobos, it will then be surrounded by sand bags and covered with loose regolith to provide more radiation shielding for the inhabitants, with external cameras providing a view of the surrounding area.

**3.1.2.2 The Modules** Each module will have its own special function and contain a unique set of supplies. One module will be for living and sleeping, one will be the command, communication, and teleoperation control center, and one will be used primarily for storage. A fourth external module will be used for nuclear power generation. To provide for quick access in the case of an emergency while the crew is sleeping, the life primary support systems will be located in the living quarters module. The center hub will act as a connection between the three modules, with a hatch on top for docking with the elevator on the tether.

As noted in the previous section, the modules will be shaped to match the fairing in which they are transported, maximizing shipment volume. The Falcon 9 fairing has a diameter of 4.6 meters and a height of 11.4 meters, with tapering occurring beyond 6.6 meters (see Figure 5) [17]. External robots and rovers can be packed within the modules for shipment. On top of each module will be a small airlock/hatch which can be used an escape route, for traveling between modules should the hub fail, or possibly for expanding the outpost by stacking other modules on-top of the existing modules. The modules will make use of a double walled design, allowing for two more layers of radiation protection to the crew as well as allowing space for the running of wires, pipes, and ventilation ducts that are safely out of the way of crew members. The double walled design also provides redundancy. If one wall is punctured, the other will retain pressure.

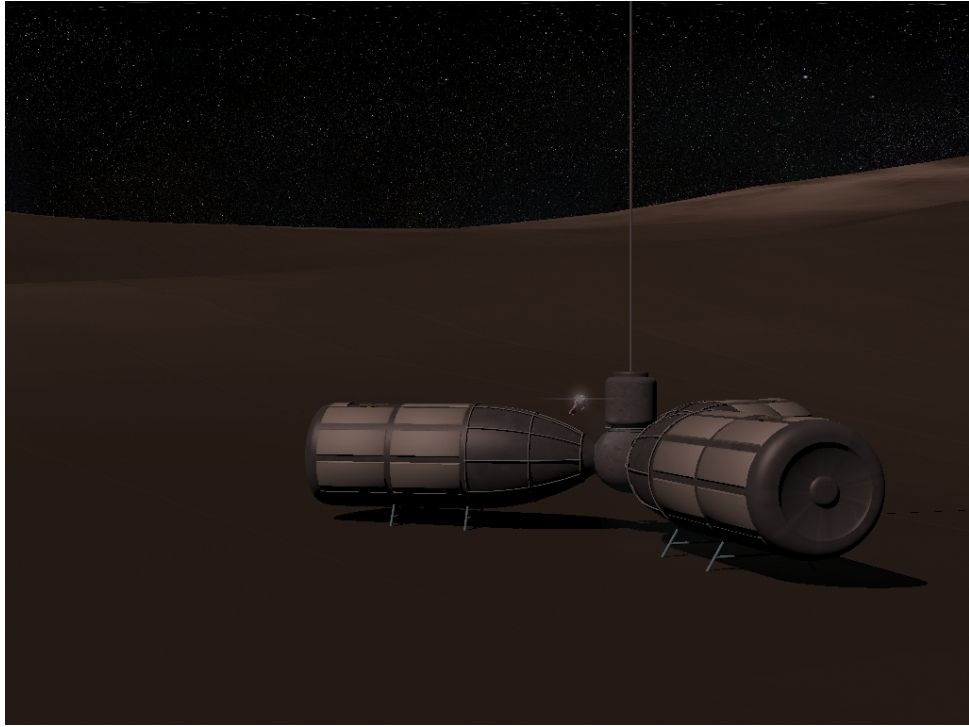

(a) Phobotian Outpost Before Covering



(b) Phobotian Outpost partially covered by Sandbags for Radiation Shielding

Figure 4: The Outpost on Phobos



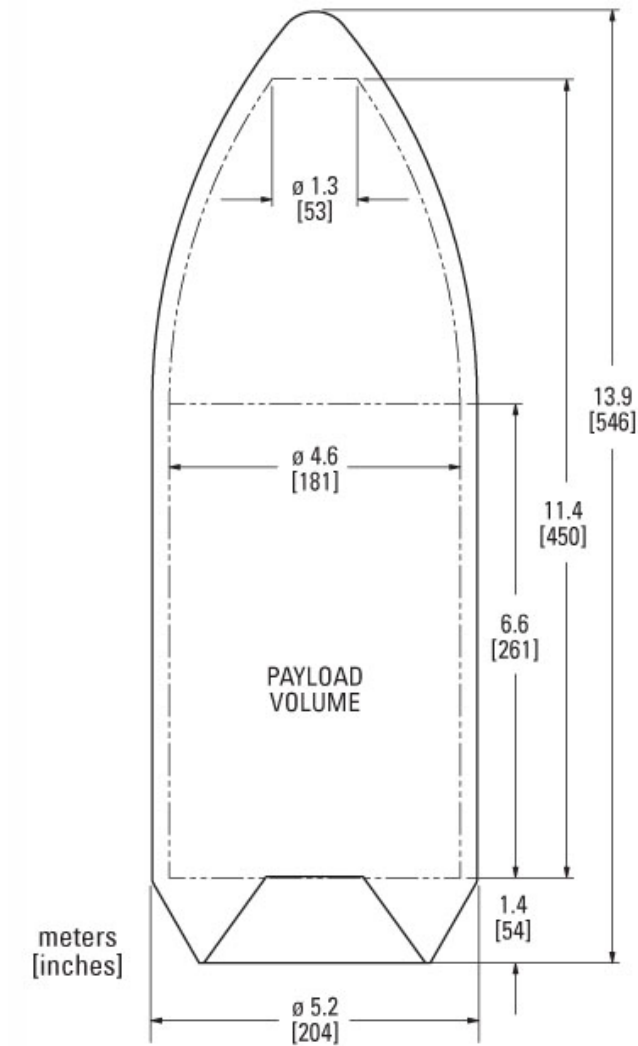

Figure 5: The Falcon 9 Fairing

**3.1.2.3 The Tether** The low gravity of Phobos makes landing the outpost and the crew on the moon difficult as dust could easily be kicked into orbit around Phobos or Mars, providing a hazard and interfere with important systems as well as create an obstacle that would have to be dealt with in future missions to Mars. To avoid this, it is proposed to land the outpost by lowering it down on a tether which passes through the L1 point 2.5 km. above Phobos. The low gravity of Phobos means the forces the tether needs to support will be minimal and within the capabilities of today's technology.

A counterweight some distance above the L1 point will act to support the counterweight and also contain communication antennas, telescopes, and solar collectors. Electrical wires within

the tether will transmit signals and power between the outpost and the counterweight. The outpost will be landed by extending the tether from the L1 point in both directions, balancing the outpost with the counterweight and reducing or eliminating the need for propulsive rockets near Phobos.

When the crew arrives to inhabit the outpost, their ship will attach to the tether at the L1 point, and the crew will travel in a small elevator to Phobos to dock with the central hub of the outpost. In this manner, communication with the return vessel would be uninterrupted, and the crew could easily travel between outpost and ship if needed. If the ship contains a centrifuge, the crew could occasionally return to it for exercise in artificial gravity, reducing the bone and muscle loss that comes with prolonged exposure to low gravity and perhaps also allowing astronauts to have some alone time in the ship, creating a social release which can help reduce the stress of spending a great number of hours confined in close quarters with the same people.

The elevator itself will help to shield the docking hatch from radiation and will provide the crew with some extra living space as well. During departure after about eighteen months (the time between flight windows) of working to assemble the Mars settlement remotely from orbit, the crew would exit the outpost in the elevator, detach their ship from the tether, and return to Earth without needed to break the hold of Martian gravity.

**3.1.2.4 Radiation Shielding** Mars has a much weaker magnetic field than Earth and thus provides far less shielding from Solar Particle Events (SPEs) and Cosmic Background Radiation (CBR) than earth. There is little if any protection as far away from the planet as Phobos, and while the moon does provide shielding on its surface from radiation coming from the opposite side of the moon, an exposed habitat on the surface would have no protection from above. Any crews inhabiting Phobos would have already spent at-least six months in deep space on the voyage there, and will spend at least another six months on the return trip. They will have already been exposed to dangerous levels of SPE and CBR, and their total dose of radiation exposure would be unacceptably high if they were not protected during their stay on Phobos. Therefore, the inhabited sections of the Phobos outpost will need to incorporate heavy radiation shielding.

Although magnetic radiation deflection and other shielding technologies are active areas of research, foreseeable protection strategies will consist of layers of specifically chosen materials.

Some types of shielding serve other functions, such as water storage tanks that line the skin of a habitat, absorbing some radiation before it enters the inhabited areas, while other, such as graduated-Z shielding, use layers of materials with different densities to successively scatter and absorb different types of radiation. However, all radiation is ultimately stopped by the nuclei of atoms, so to stop more radiation, more nuclei are needed. Full protection ultimately requires thick layers or dense materials such as lead. In either case, such shielding could not be brought from Earth because of the large cost of bringing additional mass.

The Phobotian regolith is likely a suitable radiation shielding material in thick enough layers. The Phobos outpost will cover itself in layers of the surrounding regolith thick enough to shield its inhabitants from SPE and CBR. To accomplish this, the base will have automated facilities for collecting regolith from the surrounding area, packaging the regolith into fabric sacks or "sandbags", and piling these sandbags in buttresses and walls around the perimeter of the base. The resulting space will be filled with regolith dust and the top will then be covered with another layer of sandbags. In addition to shielding from radiation, the regolith layer will provide additional protection from micrometeorites, and from the thrust jets of any docking spacecraft.

This entire process of covering the outpost with Phobotian regolith will need to be accomplished robotically after completing a successful landing as the final step in the installation process [9].

### **3.1.3 Phase 3: Mars Surface Module Deployment and Installation**

Transported alongside the crew of the Phobos Outpost will be the initial set of settlement modules for the Mars Minimum One-Way [14]. The preliminary modules will include a nuclear power plant, water source, fuel-chem module, truck-trailer, green house support, module connections, greenhouse 1, habitat 1, and laboratory modules. All of these modules will land on the Martian surface near the final settlement site. After the modules have landed, robotic vehicles will collect the modules and transport them to the final site where they will subsequently be assembled by a team of semi-autonomous robots controlled by the team on Phobos into a permanent settlement capable of supporting the first settlers.

After assembly has been completed, the base can then be remotely inspected and any functionality issues can be addressed. The power systems, life support systems, and agricultural systems would be activated with video footage of the operating base recorded robotically to be

sent to Earth. These videos could serve to help to excite public interest in the project. With this task completed, the Phobos crew will depart from their outpost after about eighteen months of work (the time between flight windows) and the permanent Mars settlers will arrive at the next available flight window, knowing a thoroughly tested and stocked settlement awaits them on the surface. Their mission is thus not so risky as to be considered a suicide mission by the public, but rather one in which the first settlers will work to expand the base further using in-situ resources.

The use of tele-operated robotics in the set-up of the permanent Mars settlement is not without merit. The productivity of tele-operated robotic systems increases roughly-linearly with decreased time-delay. [22] This means that tele-operating robots on Mars from nearby Phobos, with a negligible round trip delay of only hundredths of a second, is over forty-thousand times more productive than the same system tele-operated from Earth, with an average round-trip delay of around 42 minutes. Furthermore, it has been shown in numerous studies [4][6][21] that, although autonomous missions are more efficient, missions with humans-in-the-loop are far more adaptable and likely to succeed in the type of complex, dynamic fieldwork required to assemble and test a Mars base.

#### **3.1.4 Phase 4: Settlement**

With the construction of the Mars settlement complete, the first ever settlers will land on a foreign planet and begin exploring their new home. When the settlers arrive, the Phobos crew will have already left months earlier for their return trip to Earth., However, the settlers should be accompanied by a second Phobos crew which could assist in the settler landing and support other functions during the first few months of the permanent settlement. In effect the workload of controlling the robotic work force is removed as the first residents settle in by they can take control when they want or need to do so.

With the settlement complete, this second Phobos crew could also switch their focus to performing scientific analysis on other parts of the planet. The Mars settlers will very likely have very busy days ahead of them as they work to expand the base using in-situ resources and remote support would likely be appreciated. A second Phobos crew could also keep the outpost operational in case the settlement needs to be evacuated or could be used to set up another base at a different location on the planet. Should a second Phobos crew accompany the settlers, they would depart after about eighteen months after arriving to return to Earth, leaving the settlers

to operate alone after that, unless a third crew is considered necessary and sent from Earth to continue supporting the settlers.

The second Phobos crew could also act as a backup settlement crew. If the Mars settlement crew does not survive the landing, the second Phobos crew could take their place. They would be of the same level of Health as the initial settlement crew in regards to radiation exposure and time spent in zero gravity. If there are four people in the second Phobos crew, then two attempts could be made to land two settlers on Mars. This would help to alleviate some of the political pressure involved in spending such a large amount of money for a Mars settlement mission only to have the settlers not survive the trip and the settlement sit unoccupied.

The outpost could later be used as a refueling station or depot for future trade of resources throughout the solar system. The advanced technology developed to construct a base on Phobos coupled with the great familiarity with working with asteroid-like bodies gained by mankind at missions end will open the doors to pursuing such feats as asteroid mining. At some point asteroid mining may be a cost effective way to replenish resources that are becoming increasingly scarce on Earth. Relative to their size, asteroids contain a lot of platinum. However, resources sent to Earth from Mars or its moons seems unlikely. Martian resources will be used to create additional space infrastructure and supply that which exists. On the other hand, trade with Luna is a distinct possibility as lunar base crews will need carbon dioxide to expand agricultural production and the lunar base would have Helium-3 to trade for it.

Two months after the Mars settlement crew arrives, a second set of modules would arrive. These would have been launched on a lower energy trajectory arriving in eight months rather than the six it took for the crew to arrive to Mars. These modules would include a second habitat, a second greenhouse, and additional supplies. The purpose of the delayed modules is for redundancy. If the Mars settlement crew lands at the wrong location on Mars, the additional modules could be landed wherever the crew ended up, thus allowing them to survive until their fate could be determined, whether that be some form of rescue, or if another settlement is simply built where the settlers actually landed. In the latter case, a second settlement attempt could be made to settle the original settlement location. However, assuming the human landing was successful, the extra module will simply be attached to the completed base, expanding its capabilities.

### 3.1.5 Phase 5: Settlement Growth

As time passes, the Martian settlement would expand using mostly in-situ resources and occasional equipment re-supply trips from Earth, with the goal of becoming as independent as possible. As the base expands, additional human occupants would be sent from Earth to expand the settlement until such a time as children can be born within the colony. In addition to expanding the minimum one-way settlement, humans on Mars (possibly working with those on the Phobotian outpost), could create and transport materials to a location for the construction of additional settlements on different parts of Mars. Such settlements would likely take a different form than the simplistic minimum-one way settlement. They might be inspired by the Hillside base design.

A system of trade could be developed within the solar system, where scarce resources on one heavenly body might be supplied from another one. The problem in keeping a trade balance is that Earth has many things the space bases, hotels and colonies want and they have little to exchange for it directly. Mars will need to support and possibly feed space station crews, resupply orbiting fuel depots and the like to make the money it needs to buy sophisticated things from Earth that it cannot create by ISRU.. Phobos, Deimos, and Luna as well as asteroid mining would likely be important to this system of trade as well. Certainly Luna is likely to be a customer of Mars. The development of such a trade system would mark the beginning of a new age of mankind as a multi-planetary species.

Future expansion of the settlement will rely heavily upon In-Situ Resource Utilization (ISRU) to construct additional habitats and modules from materials collected in and around the settlement area. A few additional resupply missions will be sent from Earth to provide any replacements for unfix-able equipment and additional tools and resources that cannot be obtained or fabricated on Mars, but will not provide entire additional habitats. There are three methods for the construction of additional habitation structures on Mars with the available resources.

**3.1.5.1 Incentive for Using In Situ Resources** A mission to build a permanent human settlement on Mars is simultaneously complex and expensive. To put the costs into perspective, the International Space Station(ISS) positioned in Earth's Orbit is currently valued at over 150 billion dollars. It seems reasonable that the costs of building a permanent base on a planet 158 million miles from Earth will be significantly higher, not only because of the added complexity

that comes from building on another world, but also by the sheer magnitude of the project, the extreme distances over which resources will have to be transported, the advanced nature of the engineering and scientific challenges, the research necessary to thoroughly detail such a scenario, and numerous other difficulties which will push the price of the mission to ever higher values.

One possible way to make the trip easier to fund and accomplish is to use local “in situ”, or in position, resources in the construction or expansion of the base as much as possible as opposed to bringing the materials from Earth. The minimum one-way proposal for constructing a Martian base involves bringing the initial set of fully constructed modules from Earth and assembling them on the Martian Surface. Ideally, once the initial settlement is complete, all additional modules would be manufactured entirely from in situ resources. This would significantly decrease the colony’s dependence on supplies (and therefore, funding) from Earth.

To this end, it is important to note what resources and materials are available on the red planet and useful to look at possible fabrication techniques which could be used to turn these raw resources into materials useful to humans living on Mars. The use of in situ resources is commonly referred to as In Situ Resource Utilization (ISRU).

**3.1.5.1.1 The Atmosphere of Mars** Quite a bit is known about the composition of the Martian atmosphere because of the success of Martian rovers like Curiosity, Spirit, and Opportunity. Table 1 below shows the Martian atmospheric composition according to Curiosity [15]. As can be seen, the Martian atmosphere is mostly Carbon Dioxide which could be harvested with relative ease and used in a number of processes to produce useful products.

Trace amounts of Methane and water vapor have also been detected in the Martian atmosphere. The water can give rise to Earth-like frost and large cirrus clouds. The small amount of humidity (< 0.03%) is barely worth mentioning and it is more likely the needed water would be collected from ice deposits rather than the atmosphere.

Gas	Chemical Formula	Atmospheric Concentration
Carbon Dioxide	$CO_2$	96.0( $\pm 0.7$ )%
Argon-40	$Ar$	1.93( $\pm 0.01$ )%
Nitrogen	$N_2$	1.89( $\pm 0.03$ )%
Oxygen	$O_2$	0.145( $\pm 0.009$ )%
Carbon Monoxide	$CO$	< 0.1%

Table 1: Martian Atmosphere Composition according to Curiosity

**3.1.5.1.2 Making Fuel on Mars** There has recently been a lot of attention regarding ISRU on Mars, particularly by those interested in attempting a sample return mission, in which a craft would land on the Martian surface, collect a sample of Martian rock, create its own fuel from compounds available in the Martian atmosphere, then use that fuel to return to Earth with the sample. If such a mission is performed successfully, the fuel generation technologies used could potentially return humans from a Mars landing as well.

Currently, Explore Mars, a non-profit organization attempting to advance of the goal of sending humans to Mars, is looking to host an ISRU competition in which teams would construct a reactor capable of creating enough fuel to power a rocket for a sample return mission. The reactor would draw upon a simulated Martian atmosphere and then remotely pump the fuel into a rocket engine [16].

One potential fuel source is Methane. On Mars, Methane can be produced from in situ resources using what is known as the Sabatier reaction. The Sabatier reaction transforms Carbon Dioxide with Hydrogen at elevated temperatures (300-400 degrees C) in the presence of a nickel, ruthenium, or alumina catalysts to produce methane and water. The methane created can then be used as fuel for a return trip to earth [2]. Methane as a fuel source also requires the presence of oxygen. Luckily, the other byproduct of the Sabatier reaction is water, which can be electrolyzed to produce the necessary oxygen with the remaining hydrogen being recycled back in to repeat the process multiple times until nearly all of the hydrogen has been converted into usable methane. In April 2010, Sabatier hardware was delivered to the international space station with the hope that someday the Sabatier reaction will be able to create water from the Carbon Dioxide exhaled by astronauts. A similar system could be used on a Martian base or orbiting outpost to recycle the crew's atmosphere.

In the Phobos Scenario, humans will not land on Mars until the initial settlement has been completed, so it is unnecessary to bring large quantities of fuel to the base. However, the generation of Methane as a fuel source could be of use in preparing rockets for emergency evacuation, transporting supplies to the Mars orbital outpost, or transporting fabricated materials to a different part of Mars for the construction of additional settlement.

While the created methane's primary use will be to fuel the return vessel, it can also serve multiple other purposes. Among the other possible uses for methane on Mars



**3.1.5.1.2.1 Making Oxygen On Mars** In addition to the Sabatier reaction, there are at least two additional ways to create oxygen on Mars. The first is known as the Water Gas Shift Reaction, a reversible chemical reaction that takes Carbon Dioxide and Hydrogen and converts it into water and Carbon Monoxide. As before, electrolyzing the water creates Oxygen, which could be used either for breathing, or as the oxidizer component of rocket fuel.

Another proposed way of making oxygen is electrolysis of the atmosphere with a solid oxide electrolyzer cell using zirconia electrolysis. This process takes the carbon dioxide from the atmosphere, and using large amounts of energy, separates it into carbon monoxide and oxygen.

A third possibility to produce oxygen is to electrolyze the water from the permafrost on the surface of the planet or to dehumidify the gaseous water found naturally in the air.

**3.1.5.1.2.2 Making Plastics On Mars** Plastic is a revolutionary material for its manufacturing properties, abundance, and range of mechanical and thermal properties. Although on Earth, most plastic is made from fossil fuels, there are some plastics that can be made from organic material. One important plastic for space exploration purposes is PLA, or Polylactic Acid. With its low glass-transition temperature, this thermoplastic exhibits properties that make it excellent for injection molding 3D printing using Fused Deposition modeling. Furthermore it is strong and compostable, but not rigid. Although it is currently made in bulk from corn, it can also be made from a variety of organic sugar sources, and could even be made from agricultural bi-products and perennial plants. Furthermore, not only is PLA organically recyclable, it is also directly reusable in manufacturing. It can be melted and reformed, either by 3D printing or other processes, to recycle scrap plastic parts into new parts.

**3.1.5.1.2.3 Energy** All the energy required for these processes can be collected In Situ using solar cells on the Martian surface. There is also some evidence that wind turbines could be feasible on Mars. Nuclear power plants utilizing traditional techniques or thorium reactors could be used for power as well. The excess heat produced by the nuclear reactor could then be harnessed and re-purposed for use in industrial processes such as the production of polymers.

**3.1.5.1.2.4 The Need for Hydrogen** One problem with the use of the Sabatier reaction for generating Methane and Oxygen, or the Water Gas Shift Reaction for generating oxygen is the need for hydrogen in these reactions, which is not found in the atmosphere of Mars in any

significant quantity. Even so, acquiring it on Mars shouldn't be all that difficult so long as the settlement is located in an area with large amounts of ice, which it will almost certainly have to be, as many material fabrication processes and agriculture will need a large source of easily accessible water. Once harvested, the ice could be melted, and electrolyzed to produce all the hydrogen and oxygen needed by an early Martian settlement.

## **3.2 Additional Mission Information**

### **3.2.1 Machines**

There are several basic machines and facilities that will be necessary for any human habitat on Mars. These include atmospheric recycling and creation, water recycling, solid waste processing, power generation and distribution, lighting, temperature control, any active radiation shielding systems, and communication radios. In addition, there are two key technologies that will allow for reduced cost and risk for the mission: robotics and additive manufacturing, or 3D printing.

**3.2.1.1 Robots** Robots are the enabling technology behind preconstructed Martian bases, as well as many other aspects of the mission. The most important robots will be a small fleet of 2-5 mobile manipulation platforms capable of traveling large distances on the surface of Mars, carrying large heavy cargo, and manipulating objects and equipment. They will be outfitted with a large variety of sensors, dexterous manipulators, on board nuclear power supplies, and high-throughput two-way radios to communicate via orbital satellites with the Phobos base. These robots will be tele-operated by the crew from the Phobos base to move, assemble, and test the components of the Mars base, search for and gather natural resources on Mars, and explore features of the surface before human arrival. They may also serve as general transportation vehicles, exploration drones, and powerful tools after the crew has settled the Mars base.

Although they will share some features, such as nuclear batteries, with the semi-autonomous rovers already sent to Mars, like Curiosity, these robots will have some important differences both in design and purpose. They will not be mobile labs, as the scientific rovers are, but rather more similar to industrial robots or construction vehicles, equipped for all-terrain roving, regolith-moving, and lifting, carrying, and precisely positioning objects. Although they will undoubtedly incorporate many autonomous features, they will be designed to be easily tele-operated by humans, and this will be their primary mode of operation for accomplishing complex

tasks, such as aligning and attaching compartments for the base. They will communicate via orbital satellites, such as the Mars reconnaissance orbiter, with the Phobos base, streaming video feeds and other sensor data to human operators and receiving commands to execute in near-real time. In addition to construction, assembly, and exploration, these robots may also be used to operate equipment on the base in preparation for human arrival. This includes 3D printers in the base.

**3.2.1.2 3D printers** 3D printers and other additive manufacturing technology drastically reduces the cost and risk of space travel and manned settlement by reducing cargo weight and volume and offering vastly increased manufacturing capability and flexibility. 3D printers in particular offer three appealing possibilities.

Firstly, NASA is already investigating the possibility of 3D printing pizza and other foods during long space missions. 3D printed food could be made from a larger variety of ingredients than normal food, such as ground insects, yet remain widely appetizing through aesthetics and flavor. In addition, because the food could be printed from long lasting ingredients as-needed, those ingredients can have a much longer shelf-life than normally stored food.

Secondly, a single desktop-sized 3D printer can represent a large portion of the tools and equipment on board a typical space flight or inside a potential human habitat. With the ability to print replacement parts and tools, the need for redundant backups is eliminated. Furthermore, because the newly printed objects can have a new design, they can, in principle, be upgraded and improved, even after the mission crew has left Earth.

Finally, larger 3D printers could be used to construct elements of the Mars habitat itself. Already, some architects use building-sized 3D printers, such as the D Shape printer by Italian engineer Enrico Dini, to construct large, complex, precise structures from cement-like materials. Using a similar principle, large 3D printers on Mars could construct structural components out of the base from materials from the Mars regolith.

## **3.2.2 Space Travel/Transportation Options**

**3.2.2.1 Most Suitable Present Rocket Technology** Upon analysis of the present state of the field of rocket technology the Falcon Heavy, a design created by the team at Space X, appears to be the best fit for the needs of the mission. Although it is not yet one hundred percent

complete, the first launch is scheduled for some time in 2014, so it is reasonable to think that it will be a perfected technology in a decade. Based on of Space X's previous design of the Falcon 9 rocket, the Falcon Heavy is the newest innovation in the line of Falcon transports. Boasting an estimated load of at least fifty-three tons to LEO fifteen to eighteen tons to Mars, with plans for a newer upper stage of hydrogen-oxygen fuel that could bring that up to seventy tons to LEO, the falcon heavy has the greatest carrying capacity of a rocket on the edge of delivery today. The massive payload capacity of the Falcon heavy is due in part to two major factors; one, the use of twenty-seven Merlin 1-D engines, and two, the use of fuel cross feeding between the core booster and the two outer boosters[28].

The first stage of the Falcon Heavy is composed of three Falcon 9 first stage cores strapped together side by side and measuring eleven and a half meters (thirty-six feet) wide, with each of the three cores containing a group of nine Merlin engines, arranged in an "Octaweb" pattern, where eight engines surround one central engine [27]. Each Merlin 1D engine, the current version in the Merlin series, produces a thrust of 147,000 pounds of thrust at sea level and 161,000 pounds of thrust in space, burning a fuel of mixed liquid oxygen and rocket grade kerosene. Together the 27 Merlin engines produce a sea-level thrust of 3,969,000 pounds of thrust and a vacuum space thrust of four point five million pounds. This amount of thrust allows for the estimated one hundred and fifty tons of initial Mars habitat to be delivered with two to three rockets worth of payloads. On top of the ability to carry such a huge payload, the Falcon Heavy boosters contain an engine out ability, meaning that during take-off and flight, if one of the engines were to fail, the rocket would still be able to carry out the mission successfully [29].

In tandem with the use of the Merlin engines is the use of cross feeding between the two outer boosters and the main core booster. During the first stage of flight, the three main boosters fire, propelling the rocket upward. While this is happening the two outer cores are feeding fuel to the inner core. This cross feeding allows for the main core to be at almost full capacity when the side cores are jettisoned, allowing for a heavier payload to be carried to greater heights in the Earth's atmosphere and beyond [23].

While the payload capacity of the Falcon Heavy is something to marvel at so too is the cost effectiveness of SpaceX's rocket. With plans for the mass production of Falcon 9 boosters, with about one stage done every week with second stages being produced every two weeks, and the paralleling of systems between the 9 and heavy, SpaceX predicts that they will be able to produce

four hundred boosters per year[18]. Since the boosters are going to be mass produced the cost of their launches is much less than their competitors. The Delta 4 Heavy, with its 23-metric tonne LEO capability, costs about US \$19 million per tonne, or about US \$8,600 per pound, compared to the Falcon Heavy's price of about US \$850 per pound or US \$1.9 million per tonne - almost exactly one-tenth of the current Delta 4 Heavy price [10]. This is a huge price differential and adds to the argument for using the Falcon Heavy over other high payload rockets.

**3.2.2.2 Dragon Capsule** The main crew and cargo carrying section of the Falcon series is the Dragon Capsule also designed by SpaceX. The Dragon Capsule has multiple variants for its different possible applications; the cargo variant, Dragon CRS, the crew variant, Dragon Rider, and the research variant, Dragon Lab. The cargo variant has an internal honeycomb structure allowing for the ability to carry different sizes and shapes of cargo as well as the ability to carry pressurized cargo in its main compartment and unpressurized cargo in its trunk. The cargo variant of the Dragon Capsule is also equipped with freezers to store biological samples to and from the ISS and beyond. The Dragon Rider is currently being worked on by SpaceX with plans for it to have the ability to carry up to seven passengers safely to LEO and beyond for deep space exploration. The final instance of the Dragon is the Dragon Lab variant. The lab variant of the Dragon Capsule allows for testing equipment to be carried into microgravity environments so that tests on radiation, relativity, etc. can be performed [25].

Incorporated into every Dragon Capsule, no matter the specific function, is a set of important technologies that allow for its successful operation. Among these technologies are the capsule's main means of propulsion and maneuvering, the Draco Thrusters. The 18 thrusters, split into two pods of four and two pods of five, are powered by nitrogen tetroxide and monomethylhydrazine and produce about ninety pounds of thrust for a total of one thousand six hundred and twenty pounds of thrust with all firing at once. SpaceX is also currently working on a safer and more powerful, producing an estimated total of one hundred and twenty thousand pounds of thrust spread over eight thrusters; SuperDraco will be incorporated into the new launch escape system, allowing the Dragon to land on solid ground safely and accurately [24]. Along with the propulsion system is the Dragon GNC, or Guidance Navigation Control. The collection of optical, laser, and inertial sensors allows for precise control when in flight and also while docking [26]. The final essential technology incorporated into the Dragon Capsule's is the PICA-X heat shield. With

the potential to withstand hundreds of Earth re-entries and even Moon or Mars re-entries with minimal degradation, this is the most advanced heat shielding today and guarantees protection to the cargo inside, whether organic or not [30].

**3.2.2.3 Technology appearing in the Next 20 Years** Years Although the Falcon Heavy is in the present day top-of-the line, Musk and SpaceX have indicated that they do not plan to stop there. SpaceX founder Elon Musk and president Gwynne Shotwell have both expressed interest in developing a Falcon Super Heavy rocket. They claimed that, like the Falcon Heavy, the Super Heavy would be economically impressive with an estimated launch price of approximately one thousand dollars per pound or about three hundred million dollars per launch. For a launch that has an estimated LEO payload of one hundred and fifty tons, SpaceX's proposed rocket is another economically feasible option when the design becomes finalized and production begins. However, planning a mission to start in ten years around a rocket that is still not even on the drawing board today is risky. This rocket may later become a factor in determining how many settlers can migrate to Mars at the same time.

**3.2.2.3.1 Magnetoplasma Rockets and the VASIMR Engine** A new innovation in Rocket propulsion technology is currently in development which promises to shorten the flight time between Earth and Mars by over four months. The VASIMR engine, Variable Specific Impulse Magnetoplasma Rocket uses no liquid or solid fuel but uses gas as a propellant, with proposed propellants including helium, deuterium, hydrogen, and xenon. The rocket fires by first ionizing the gas molecules of the fuel into a plasma in the helicon coupler. Next, while super-conducting magnets are linearizing the motion of the plasma particles, the particles are passed through another coupler called the ICH coupler which increases the acceleration and temperature, up to one million degrees Kelvin, of the particles. As the ions are rotating around the elongating magnetic field lines they reach speeds of up to one hundred thousand miles per hour [1].

Of all of the options for fuel that the VASIMR engine has, the best choice when weighing out all the pros and cons is probably hydrogen gas. Elemental hydrogen is highly abundant in the universe, allowing for the ability to refuel no matter where you are as long as the proper equipment is present. This enables launches with the VASIMR engine to take place with only enough fuel to get to the destination as refueling can occur once there for the return trip home.

On top of its overwhelming abundance hydrogen is attractive due to its ability to act as a radiation shield. If the storage of fuel is integrated correctly into the rocket, i.e. in between an outer radiation shielding shell and an inner crew quarters shell, the fuel can act as a secondary layer of shielding, creating an even safer environment for crew and cargo [19].

Although there are many positives to the application of VASIMR engines to spaceflight there is one negative to take into consideration, its massive power consumption. To send a mission taking advantage of the VASIMR engine to Mars, 200 megawatts of power must be generated. This a large amount of power to generate and with the size limitations brought about by a spacecraft it could be a technological bottleneck in moving to the next generation rocket engine.

Currently there are a couple possible power sources being looked into for the eventual powering of these engines. One of these is the possibility of solar panels being used to power the engines. However, to date the most efficient panels have a mass to power ratio of 20 kg/kW, which would lead to a requirement of about four million kilograms of solar panels, making it not worth the trouble. However, DARPA is currently looking into the development of more efficient solar panels leading to mass power ratios of 7 and even 3 kg/kW, which would greatly decrease the mass of solar panels needed.

The other option for power is nuclear power. This is a much more probable source but still at a low technological readiness level. Ad Astra, the company behind the VASIMR engine, is currently working on designs for reactor that could do the job but that R and D initiative is far from complete, The only reactor ever to be launched in space by the U.S. boasted a mere 50 kg/kW mass to power ratio. Though that launch was in 1965, there is a long way to go from where we are today [8].

**3.2.2.4 Advanced Radiation Shielding** While the radiation exposure of humans living on the surface of Mars is expected to be comparable to that for astronauts currently on the ISS, the radiation levels in deep space that crews would be exposed to on the trip(s) there are dangerously high. Most current proposals for interplanetary manned spacecraft include the use of water storage tanks around the skin of the inhabited parts of the spacecraft for radiation shielding.

Another type of shielding already employed to protect sensitive satellites and electronic equipment is Graded-Z Shielding, which combines layers of materials of graduated densities, each ab-

sorbing the radiation scattered from the previous, resulting in a shield which provides protection from a variety of radiation types but maintains low mass and thickness.

Overall, the best method of reducing the radiation exposure of future colonists will be reduction of the travel time from Earth to Mars by developing advanced propulsion technologies. Careful selection of crew candidates by age, gender, and genetic factors will also reduce their risk of developing cancer from high radiation exposure.

As for radiation exposure for the settlers on the surface of Mars, although the levels are low compared to interplanetary space, they are still high compared to Earth's surface. The best option for radiation protection is to cover the habitats in Martian regolith. According to NASA's HERRO study, "Sixteen feet (5 meters) of Martian soil provides the same protection as the Earth's atmosphere — equivalent to 1,000 grams per square cm(227.6 ounces per square inch) of shielding [13]."

## 4 Findings

### 4.1 STS Class Survey

#### 4.1.1 Experiment Overview

Worcester Polytechnic Institute offers a course (The Society-Technology Debate, STS 2208) which includes sections in which the students consider the nature of technological societies, their mentalities and mindsets, and the characteristics of technology that humanistic critics find problematic or objectionable. It also delves into the relationship of scientists and technologists to scientific advancement.

A questionnaire was given to this year's B term STS (Society/Technology Studies) class which enabled the scenario group to get reactions to the Phobos First Scenario from a group of about thirty students representing both the interested and informed public, and people role playing a simulated government body. In this case, they were actually simulating the Congressional committees that control the funding of science and civilian space projects. This study gauged their perceptions of the feasibility and desirability of a Mars settlement mission.

The participants in the STS class were first asked to read over a leaked description of the Phobos First Scenario, to familiarize themselves with the different stages in the proposed initiative to set up a Phobotian Outpost and eventually a Martian settlement.



The space debate came up in the context of what robotics capabilities and applications should be stressed in government funding? Bills were under consideration to reduce DOD funding of the field of robotics from 85 percent today to about 50 percent by shifting development funds to another government agency. NASA was under consideration to be the main beneficiary of this rearrangement and it was hoped that the space agency would emerge as the co-lead agency funding and shaping the field.

The following day, after the "leak" of upcoming testimony, the participants completed a questionnaire of four questions upon entering class, responding to each section out of character, as well as producing a comment on their opinion of the Phobos First mission. The project team, then in character as a group of NASA professionals, presented the scenario as NASA testimony to the class members who were now in character as groups of Congressmen and Senators listening to proposals for the reallocation of government funds in the science and technology sector.

Following the presentation, the participants had a brief time to ask questions to the NASA representatives about different aspects of the scenario, such as why mankind should go to Mars when the money can be spent dealing with the problems on Earth? After the questioning period, the participants completed another questionnaire with the same four questions. This time they responded in character as their respective Congressional representatives. After the second round of responses was completed and had been collected, the proposing NASA team from JPL left and a discussion was conducted, in character, as to whether or not funds should be redistributed to allow the NASA group to begin preparation for this endeavor. After much discussion, the role playing students decided, not unanimously but by a clear majority, that the funds would not be given to the Mars colonization group but instead would be distributed to an alternative space base project involving a manned lunar base and resource harvesting especially of oxygen and helium-3. Note that before the Phobos scenario was presented, it seemed unlikely that robotic deployment funds would be allocated to the lunar mission, but by comparison to the Mars mission, which had a less tangible yield, the less dramatic and expensive Lunar proposal looked like a moderate, rather than radical, proposal.

Materials for this quasi-experiment including the documents provided to the students and copies of the questionnaire that was distributed can be found in appendix A.

### 4.1.2 Analysis of Data

The STS class study provided a sampling of not only the interested and informed public, in the form of future engineering industry professionals, but also of a simulated government body, and their perceptions of the feasibility and desirability of a Mars settlement mission. While the final group decision did not fund an immediate Mars settlement program, the legislation that came out of committee funded some robotic R and D activities of use to both missions. It also specified that the Mars base project immediately follow the completion of the lunar base. Claims that the lunar base project could pay for itself as well as feed itself were decisive in having it get priority. However, the recent landing of the Chinese Jade Rabbit rover on the moon was also a factor. It seemed that a new space race, justified by economics this time, was in the opening. The data the team received did show an overall positive outlook on the possibility of settling another celestial body and space activity in general. The overall perception appears to be that the Phobos Scenario is both politically appealing and technologically feasible, at least to the technologically literate audiences it was presented to.

After the presentation of the scenario, there was an in depth discussion regarding the desirability and feasibility of the proposed endeavor. The collection of technical students who were exposed to the scenario agreed that the technological aspects of the scenario provided were feasible within the given time frame (within the next 10-20 years). The major hang-up that they had with our scenario was the political and economic desirability of settling Mars. When proposed alongside a robotic mining base on the Earth's moon, they could find no reason to go to Mars instead. The collective wisdom was that a moon settlement would provide a greater economic benefit with the resources it would produce, i.e. helium 3, as well as provide a greater political benefit, as it would fuel political competition with China to see who could occupy the Moon first. We say occupy rather than settle because these are not one way trips but rather one year deployments to the moon. The financial risk and the risk to human life and rights were also perceived as much less for a settlement on the Moon as supplies and crew could be sent to the base more expediently than is possible for a Martian settlement.

After a lengthy and heated deliberation, the Moon settlement was chosen over the Martian settlement, however, an interesting discovery was made. According to Beau Donnan, the main researcher in the STS class, a framing effect took place in which the Moon scenario was accepted because a Mars scenario was present. In other surveys taken Beau found that when presented

with only one space exploration/settlement proposal, the audience was hesitant to accept it as the risk and cost were both high when compared with the propositions given that would occur on Earth. However, when a group was presented with two scenarios involving space, they seemed more willing to accept and fund an ambitious space mission-scenario, specifically the one they perceived as less risky and less questionable from an ethical standpoint. The Mars proposal was more exciting but harder for the practical politician, rather than a technological visionary, to accept. From this it can be inferred that if a group of decision makers, like those in a Simulated Congressional committee, were to be proposed a scenario for the exploration/settlement of an extraterrestrial colony, they would be most likely to accept it if they simultaneously proposed a more extreme case of a space program that greatly exceeded the capacity of currently available technology.

Another major topic of debate the simulated government body discussed was on the level of capability of robotic technology. Initially the group, comprised of forty-five percent robotics engineering (RBE) majors, was divided, it was the non-RBE group that questioned the capabilities of robotic technology when applied to the development of a Martian colony. By contrast a majority of the RBE majors in the class believed that with humans in the loop robotics, the construction of the proposed base was quite possible. A few extremists in the RBE part of the class argued against the mission on the grounds that advancements in robotic technology were being underestimated. The idea of humans in the loop robotic manipulation appealed to the majority in that if something went wrong, a robot may not be able to remedy the problem successfully on its own. With a human monitoring the robot, the person could take over and institute counter measures to avoid possible disaster, saving the mission and the investment. With humans in the loop actively working to avoid problems, the possibility of irreversible damage being done by or to the robots is mitigated. Thus, investments by the government and private companies are protected.

The smaller RBE group believed that the future capabilities of robotics were being underestimated, and that within the time-frame given, robotics would be at the point where robots could successfully operate autonomously and self-remedy any problems encountered. This argument effectively negated the need for a Phobos outpost. In the end, the majority of robotics majors successfully convinced the rest of the class/government body that robotics with human monitoring would provide a viable approach to the establishment of the initial Martian settlement.

Since one of our goals was to convince people that the mission was feasible this represents a partial success due to our efforts.

From the pre-presentation data, where the class replied to the survey out of character, there was general support for both the Phobos First scenario and Mars settlement in general. When asked about the possibility of such a scenario occurring in the future, 81.9 percent of the class thought it would be likely to occur at some point in the future (66.7 percent replied with somewhat likely, 15.2 percent replied with very likely). When queried about the value of space exploration in the second part of the survey, again the responses received reflected an overwhelming support for the proposition, with 81.8 percent of the responders reflecting that they believed that space exploration was a valuable endeavor (63.6 percent replying that exploration is very valuable and 18.2 percent responding that they believed it is somewhat valuable). When the technology behind the proposed exploration and settlement came into question, while current technology was not accepted as adequate, technology currently in research and development as well as technology in the foreseeable future were perceived as adequate for the mission. About 80 percent of the class believed the technology necessary for the proposed scenario would be available at some point in the foreseeable future (2.9 percent replied that it could be done with technology currently in use, 38.2 percent predicted technology currently in R and D would be needed but it was still feasible., 2.9 percent were in between technology in R and D and foreseeable technology, and 38.2 percent believed technology in the foreseeable future would be capable of performing the tasks required, but not that currently under development. Finally, the class was asked to express when they believed space exploration beyond the moon, and/or space colonization, would begin?

Again our proposing group received positive feedback from the technically literate sample. About 45% responded that they believed it would be achieved in this generation's professional lifetime. About 9% believed it was possible within the next ten years. 35% responded that they believed it was possible within the next fifty years, About 50% believed that it would be within the next century. That this is the period when humanity will move beyond the moon with manned exploration and would probably begin settling an extraterrestrial body is quite a claim. They expect to see the opening of a new era in the history of mankind.

Similar patterns of findings were found in the questionnaires completed following the presentation of the scenario to the class. Again there was a great deal of support and faith in the

scenario not only being possible but likely to actually be carried out sooner rather than later. The positive feedback received from the class reflects a possibility that further space exploration and settlement projects are not beyond the realm of possibility. Important scientific and technological pursuits in the near future will include space projects that were probably not possible and certainly were not feasible without robotic technology. They are expected to be a big part of the current generation's life experience and many of the robotics majors were seeing their dream jobs described. They would much prefer to work on an ambitious space mission than for the Military. Figures 6, 7, 8, and 9 depict the survey results. Raw data can be found in tabular form in appendix A.

## **4.2 Presentation By Museum Group**

The counterparts to the Phobos First IQP group, the Mars exhibit group, attended the November 2013 YPSE conference in Baltimore with Professor John Wilkes. While there, they made a presentation to a technically sophisticated audience of industry professionals and opinion leaders that discussed both their ideas about what an exhibit depicting the scenario might be like and the goals and means of the real mission being proposed by us. The latter part of the presentation was based on images and materials provided to them by the Phobos First group on the scenario itself.

According to the attending members of the group and Professor Wilkes, both the exhibit presentation and the scenario were well received. In the words of Professor Wilkes, "Of all the presentations theirs was the most well received, the most discussed – and the best presentation." The positive reception of the proposed Martian settlement scenario by this audience and experienced by the exhibit group reflects an acceptance of the technical viability of the Phobos First scenario. There was more debate about the envisioned time-line in which such an undertaking could be completed. The scenario's depth of investigation and analysis of possible outcomes provides a final product that has the ability to influence opinion leaders in the various fields necessary for its completion and especially robotics.

**Pre-discussion (out of character): How likely is it that this scenario could come about?**

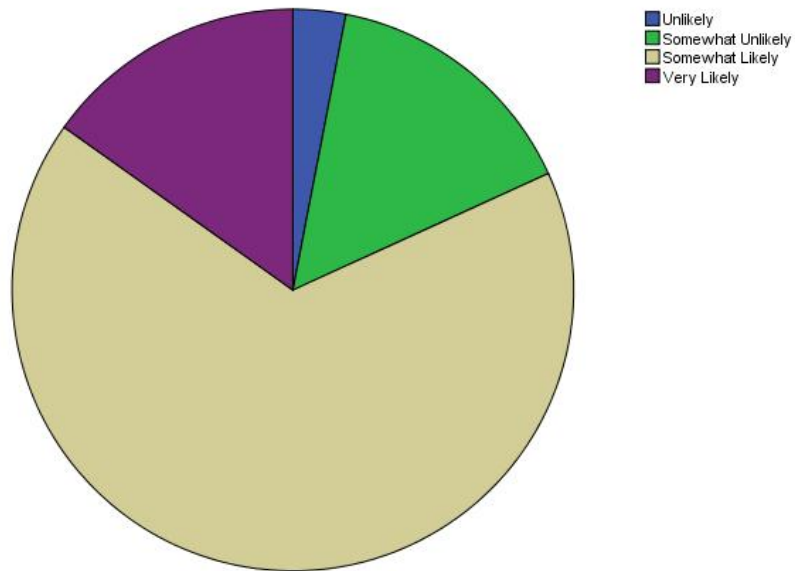

(a)

**Post-discussion (in character): How likely is it that this scenario could come about?**

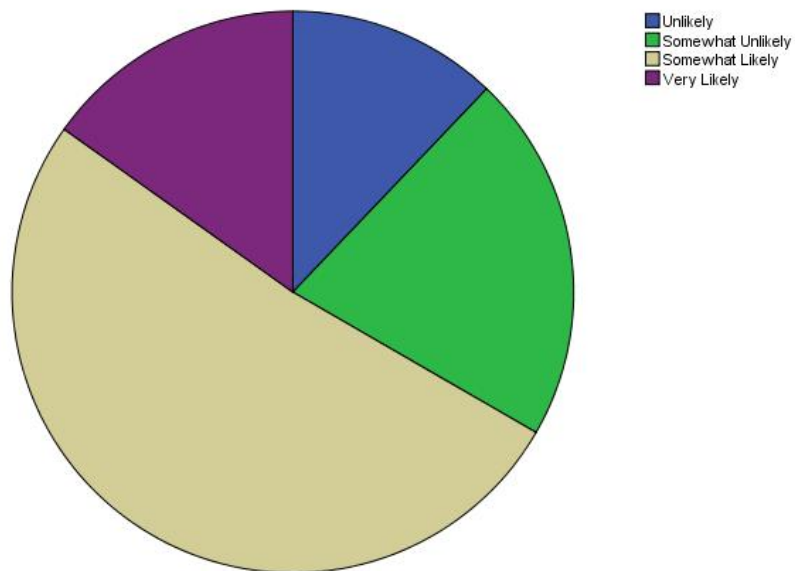

(b)

Figure 6: Results of the STS Class Survey: Scenario Likelihood

**Pre-discussion (out of character): How valuable are investments in space exploration?**

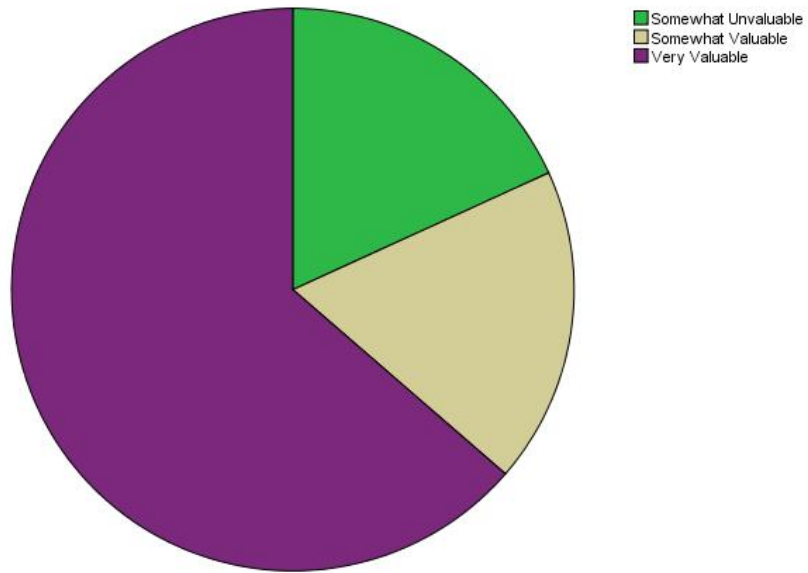

(a)

**Post-discussion (in character): How valuable is this investment in space exploration?**

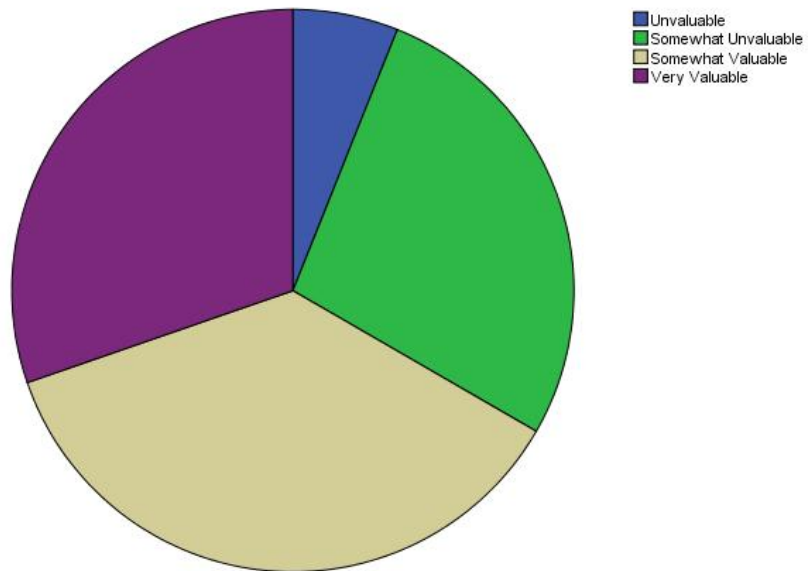

(b)

Figure 7: Results of the STS Class Survey: Investment Value

**Pre-discussion (out of character): What technologies are required for human space exploration and colonization?**

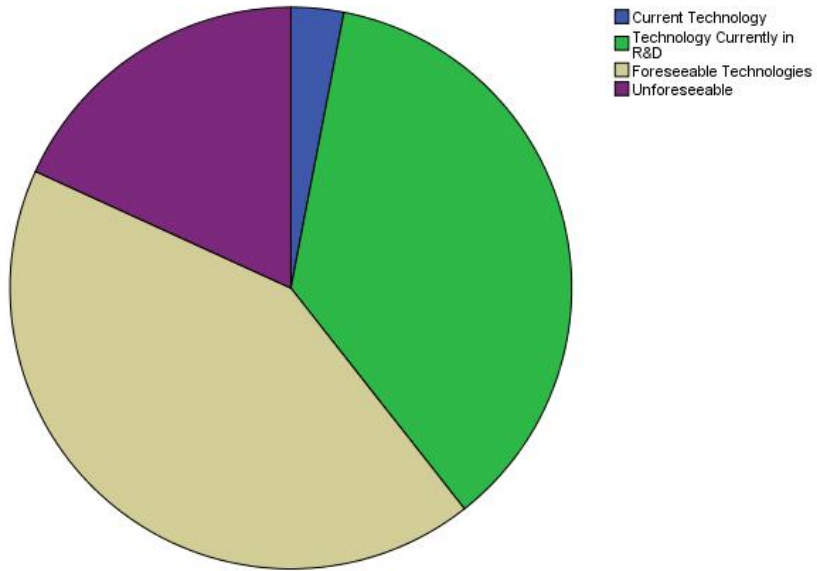

(a)

**Post-discussion (in character): What technologies are required for this space exploration project?**

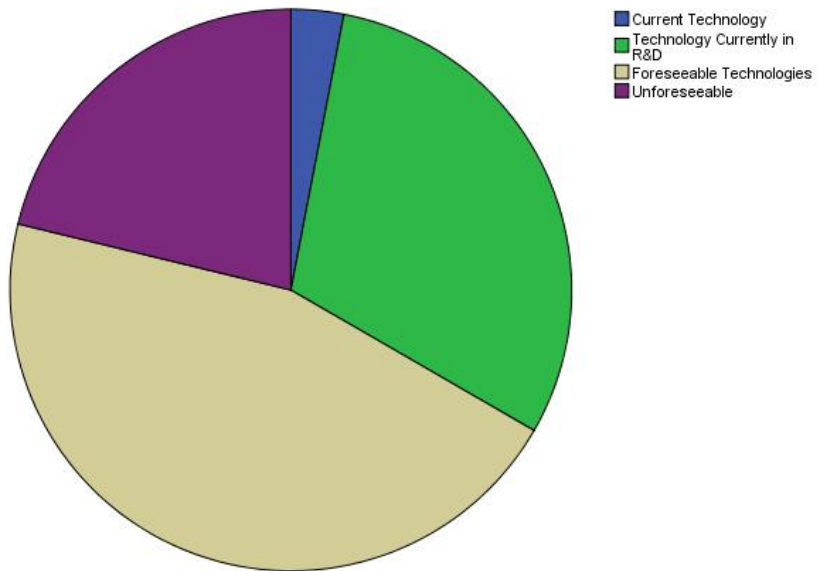

(b)

Figure 8: Results of the STS Class Survey: Required Technologies



**Pre-discussion (out of character): When will manned space exploration beyond the moon or space colonization begin?**

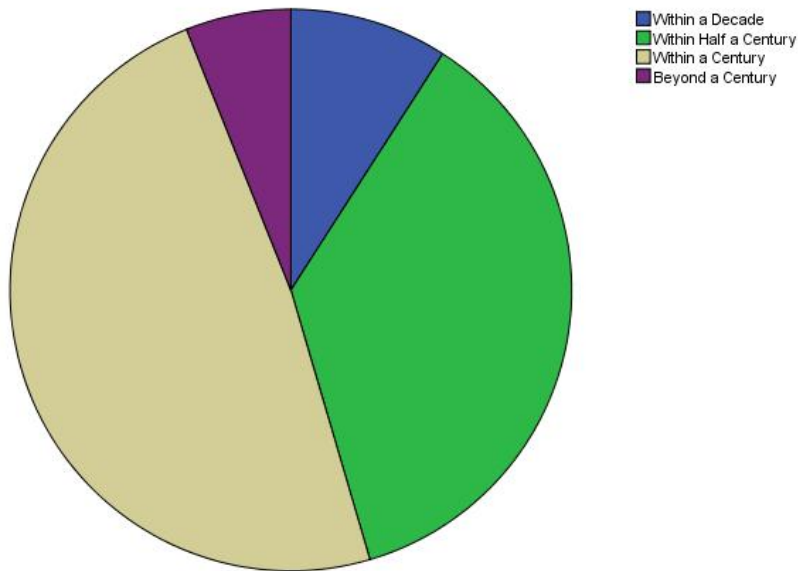

(a)

**Post-discussion (in character): What is an appropriate time frame for the execution of this mission?**

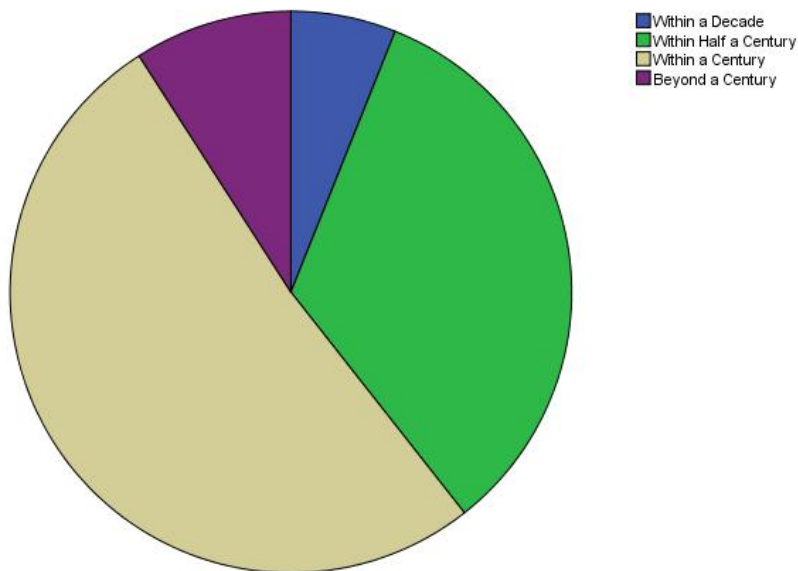

(b)

Figure 9: Results of the STS Class Survey: Appropriate Time Frame

## 5 Summary and Conclusion

The risks involved in the creation of a Mars settlement, both financially and to human life, are high and are impossible to fully negate, and while most proposed approaches for Mars settlement are highly risky, the Phobos First scenario is an effort to minimize those risks. In many scenarios involving the colonization of Mars, the first crew is transported directly to the surface of the Martian planet, and is never able to return to Earth due to the Martian gravity well and the costs involved in overcoming it to reach orbit. However, in the Phobos First scenario, the crew first lands on Phobos which allows for easy escape back to Earth in the event of an emergency thanks to the almost nonexistent gravity on the Martian moon. From Phobos, the crew assembles the Mars settlement using semi-autonomous robots, further reducing the risk to human life. No one is put at risk due exposure to the harsh Martian conditions. With the settlement habitat for people and plants completed, all systems can then be tested, further reducing risk to human life by preventing potential malfunctions in a major life support system. Finally, when the first settlers arrive on Mars they will be met with a fully supplied, fully operational home as opposed to other scenarios where the base has to be constructed by the settlers.

The location selected for the new Martian colony will be monitored for a little over a year. If at any point conditions prove unfavorable or there is a serious malfunction during the setup of the Martian settlement, the whole mission can be aborted and the resources that would have been wasted on a futile mission could be saved. Phobos First, A Mission To Settle Mars, not only provides a feasible solution to one of mankind's greatest long term dream endeavors, it does so in a way that will protect lives and minimize resource losses so as to increase the social and political acceptability of the proposed project. It does so by reducing the perceived risk as much as the actual risk. Thus, the lack of a short term economic incentive to undertake the mission is mitigated and one of the major ethical objections to the mission plan is countered.

The recognition of these logistical advantages and risk-mitigation is evident in the survey results and reactions of relevant audiences. A section of the interested and technologically literate public is represented by the STS class, while the YPSE conference contained current and future professionals in the space industry. The scenario was well received by both groups, and was favored over competing Mars colonization scenarios, including direct plans with subsequent homestead development. However, concerns remained about the social and political implications of the ethical dilemmas the scenario presented, namely the one-way nature of the first few crew

missions. Even in previous historical settlement situations, such as the pilgrim's voyages to the new world, there existed the possibility of returning to the main civilization, where that possibility is absent from the Phobos First Scenario. This problem made the initial settlement missions highly controversial, especially when pitched against alternative space missions, such as moon bases. However, when viewed as a cultural quest, the Phobos First presentations were successfully in convincing these audiences of the feasibility and value of the basic scenario. Perhaps more importantly, the scenario was successfully in engaging the relevant public audiences in the debate about the value and feasibility of large-scale space initiatives, and in convincing the audiences that investment in space technology and missions has merit, while also informing them of the great challenges that must be overcome. Thus, most of the contention received was not related to feasibility or desirability, but to specific social and political implications and problems. What rights would colonists have? What nations or private corporations would participate in such initiatives? Who is responsible and liable if something goes wrong? These and similar questions were not directly addressed in the main scenario description, but their very appearance indicates that the presentation of the scenario was enough to convince the audiences that the scenario could and should happen, leaving them only to ask how it could be implemented politically and socially. For these aspects, the most influential factor was education about space and the recognition of the real challenges and benefits of its exploration in the face of political controversy. As Apollo 14 astronaut Edgar Mitchell said, "You develop an instant global consciousness, a people orientation, an intense dissatisfaction with the state of the world, and a compulsion to do something about it. From out there on the moon, international politics look so petty. You want to grab a politician by the scruff of the neck and drag him a quarter of a million miles out and say, 'Look at that, you son of a bitch.'"

## 6 Acknowledgements

This work was sponsored in part by the Mars foundation, which provided essential resources including comparative Mars settlement scenarios for reference, general technical advice on formulation of the scenario, assistance in revision and presentation, and for their role as a media outlet.

The authors would also like to thank a few additional parties who made the formulation of

the Phobos First Scenario possible, particularly the project adviser, Professor John Wilkes and the Mars Foundation Consultant Bruce Mackenzie.

Professor Wilkes provided a great deal of guidance, knowledge, and support throughout the project. His scrupulously thorough review of the original draft helped to shape this paper into a superior form. His tremendous influence can be seen in all parts of this paper, and is particularly material in areas with a strong historical element. Additionally, his political and social science experience as well as his connections to experts such as Dan Anderson, who enlightened the team about space agriculture, helped to build a stronger case to support the Phobos scenario by helping to ensure feasibility and acceptance in these areas.

Bruce Mackenzie willingly donated his spare time to aid the team in pursuit of a technologically sound proposition and provided extensive advice, technical wisdom, and access to his many resources and contacts in the space community. He helped to keep the team focused on the end-goal when the team was working in unfamiliar territories. His wisdom in space development shaped and influenced the core of the Phobos-First scenario, finding dozens of flaws and suggesting countless modifications the team would have otherwise failed to detect.

Additionally, the team would like to thank Beau Donnan for the addition of the Phobos Scenario feedback studies to his existing society-technology study and provided access to his previously collected data and the STS class for providing valuable feedback to the proposed scenario, allowing for the evaluation publicly perceived feasibility of the proposed mission.

Finally, the authors would like to thank Worcester Polytechnic Institute, for providing the opportunities to perform great projects such as this one and gaining access to a wealth of expert knowledge as well as real world experience solving the complex and challenging problems facing mankind.

*“Mars has been flown by, orbited, smacked into, radar examined, and rocketed onto, as well as bounced upon, rolled over, shoveled, drilled into, baked and even blasted. Still to come: Mars being stepped on.” - Buzz Aldren*

## Bibliography

[1] AdAstra. Our engine, 2013.

<http://www.adastrarocket.com/aarc/VASIMR>.

- [2] Robert A. Braeunig. Rocket propellants, 2008.  
<<http://www.braeunig.us/space/propel.htm>>.
- [3] Ron Cowen. Radar probes frozen water at martian pole. 2007.
- [4] Ian A Crawford. Dispelling the myth of robotic efficiency: why human space exploration will tell us more about the solar system than will robotic exploration alone. *arXiv preprint arXiv:1203.6250*, 2012.
- [5] Marcia Dunn. International space station gets resupplied, courtesy of nasa’s shuttle atlantis. *Huffington Post*, 2011.  
<[http://www.huffingtonpost.com/2011/07/11/international-space-station-supplies-nasa-shuttle-atlantis\\_n\\_894444.html](http://www.huffingtonpost.com/2011/07/11/international-space-station-supplies-nasa-shuttle-atlantis_n_894444.html)>.
- [6] B Glass, G Briggs, J Jasper, and K Snook. Evaluation of human vs. teleoperated robotic performance in field geology tasks at a mars analog site. In *Proc. 7th i-SAIRAS*, volume 3. Citeseer, 2003.
- [7] Joshua B. Hopkins and William D. Pratt. Comparison of deimos and phobos as destinations for human exploration and identification of preferred landing sites. *AIAA SPACE 2011 Conference & Expositions*, 2011.
- [8] Jeremy Hsu. New rocket engine could reach mars in 40 days, 2010.  
<<http://www.space.com/8009-rocket-engine-reach-mars-40-days.html>>.
- [9] Daisuke Inoue, Yoshitaka Yanagihara, Hiroshi Ueno, and Shin’ichiro Nishida. Model tests of regolith packaging mechanism. 2012.  
<<http://www.fujipress.jp/finder/xslt.php?mode=present&inputfile=ROBOT002400060013.xml>>.
- [10] John K. Strickland Jr. The spacex falcon heavy booster: Why is it important?, 2011.  
<<http://www.nss.org/articles/falconheavy.html>>.
- [11] V. P. Kostama, M.A. Ivanov, J. Raitala, T. Törmänen, J. Korteniemi, and G. Neukum. Evidence for multiple ice deposits on the northeastern rim of hellas basin, mars. *Earth and Planetary Science Letters*, pages 321–331, 2010.

- [12] Geoffrey A. Landis. Footsteps to mars: An incremental approach to mars exploration. *Journal of the British Interplanetary Society*, 1995.  
<<http://www.geoffreylandis.com/Footsteps.pdf>>.
- [13] Bas Lansdorp. Radiation fears shouldn't hold back mars colonization (op-ed), 2013.  
<<http://www.space.com/21813-mars-one-colony-space-radiation.html>>.
- [14] B. Mackenzie and N. Brackley. A minimum, one-way, mars settlement program.
- [15] Paul R. Mahaffy, Christopher R. Webster, Sushil K. Atreya, Heather Franz, Michael Wong, Pamela G. Conrad, Dan Harpold, John J. Jones, Laurie A, Heidi Manning Leshin, Tobias Owen, Robert O. Pepin, Steven Squyres, Melissa Trainer, and The MSL Science Team. Abundance and isotopic composition of gases in the martian atmosphere from the curiosity rover. *Science Magazine*, 2013.  
<<http://www.sciencemag.org/content/341/6143/263.abstract>>.
- [16] Explore Mars. Mars in situ resource utilization challenge overview, 2012.  
<<http://www.exploremars.org/mars-in-situ-resource-utilization-challenge-overview>>.
- [17] marssettlement.org. The mars surface hab (msh, or "the hab"), 2013.  
<<http://marssettlement.org/2013/05/08/the-mars-surface-hab-msh/>>.
- [18] Elon Musk. Falcon heavy press conference, 2011.  
<<http://shitelonsays.com/transcript/spacex-next-falcon-heavy-press-conference-2011-04-05>>.
- [19] NASA. Propulsion systems of the future, 2003.  
<[http://www.nasa.gov/vision/space/travelinginspace/future\\_propulsion.html](http://www.nasa.gov/vision/space/travelinginspace/future_propulsion.html)>.
- [20] Georgi Petrov and Bruce Mackenzie. Mars homestead project.
- [21] Ken Pounds and CBE FRS. Report of the commission on the scientific case for human space exploration.
- [22] George R Schmidt, Steven J Oleson, Stanley K Borowski, and Geoffrey A Landis. Herro: A science-oriented strategy for crewed missions beyond leo. In *48th AIAA Aerospace Sciences*

*Meeting Including the New Horizons Forum and Aerospace Exposition*, pages 2010–629, 2010.

- [23] Dr. Erik Seedhouse. Falcon 9 and falcon heavy: Life after the space shuttle, 2013.  
<[http://link.springer.com/chapter/10.1007%2F978-1-4614-5514-1\\_5](http://link.springer.com/chapter/10.1007%2F978-1-4614-5514-1_5)>.
- [24] SpaceX. Draco thrusters, 2013.  
<<http://www.spacex.com/news/2013/04/04/draco-thrusters>>.
- [25] SpaceX. Dragon, 2013.  
<<http://www.spacex.com/dragon>>.
- [26] SpaceX. Dragon guidance navigation control (gnc) bay, 2013.  
<<http://www.spacex.com/news/2013/05/16/dragon-guidance-navigation-control-gnc-bay>>.
- [27] SpaceX. Falcon 9, 2013.  
<<http://www.spacex.com/falcon9>>.
- [28] SpaceX. Falcon heavy, 2013.  
<<http://www.spacex.com/falcon-heavy>>.
- [29] SpaceX. Merlin engines, 2013.  
<<http://www.spacex.com/news/2013/03/26/merlin-engines>>.
- [30] SpaceX. Pica heat shield, 2013.  
<<http://www.spacex.com/news/2013/04/04/pica-heat-shield>>.
- [31] John M. Wilkes. Relevant Historical Information. Unpublished Interview, 2014.
- [32] Robert Zubrin and David Baker. Mars direct: Combining near-term technologies to achieve a two-launch manned mars mission. *Journal of the British Interplanetary Society*, 1990.  
<<http://adsabs.harvard.edu/abs/1990JBIS...43..519B>>.

## A STS Documents, Surveys, and Analysis Results

*The following is a pre-release of a cover story detailing a new space colonization proposal developed by NASA*

## **Robots Construct a Mars Settlement, Controlled Remotely from Martian Moon Phobos**

By the launching of the first components of the International Space Station (ISS) in 1998, a tremendous project was undertaken to join the people and nations of the world together in space. Fifteen years later, that declaration stands. 204 individuals have now visited the station, now the size of a football field, with more living area than a conventional 5 bedroom house.

Meanwhile, a world away, the Mars Curiosity Rover, landing in 2011, semi-autonomously navigates terrain and shoots lasers at rock, all in the pursuit of science and exploration. Robots are now changing not just our world, but other worlds. As the technology grows more capable, the dreams grow bigger; the possibilities, more extreme; the opportunities, endless.

2035: The initial seed modules for the first human Mars settlement have arrived safely on the surface of the red planet, along with a fleet of highly-capable robots, which lay dormant, awaiting instructions. A separate outpost, assembled in low-earth orbit, has previously been sent to the Martian moon, Phobos, where it had autonomously installed itself on the small asteroid-like body, it's docking tether reaching towards Mars, which looms large in the black sky above.

Now, a new ship from Earth arrives and hovers just a couple kilometers above the outpost, attaching to the tether. Its crew of four humans descend down the tether to the outpost in an elevator. Upon boarding, the operators settle in and ensure all systems are operational, then begin work. For the next year, these human operators remotely control the Robots on the Martian surface to assemble the modules into humanity's first permanent offworld colony. Digging wells for water, assembling the living modules, planting greenhouse, routing power conduits: the crew oversees all necessary operations on Mars remotely from their outpost, orbiting safely above, with the assurance that they can always abort their mission, board their ship, and return to Earth, if necessary.

Eventually the Martian base, snuggled next to a glacier on the edge of a sprawling crater, is finished and its systems are thoroughly tested. With this Mars settlement established and operational, the mission of the Phobos crew is almost complete. The first two permanent human settlers, a man and a woman, arrive from Earth and land on Mars and the Phobos crew relinquishes the base they've constructed to it's new occupants. Once these first settlers are well established in their permanent homes, the Phobos crew bid them good luck and farewell from orbit, then return to their families on Earth. The Mars couple, however, can never leave - the gravity well of Mars is too strong to afford them that comfort. Thankfully, through the efforts of the Phobos operators and their robotic counterparts, they won't have to leave. They have everything they need to survive, to thrive, and to grow. This was not a suicide mission, a mission to put people on Mars just to see if we could, knowing full well that they would not survive long. This was a mission to transform the human race, break free of the confinement of Spaceship-Earth, and start settling the solar system as a multi-planetary species.

Utilizing the resources of the planet, the robotic construction team, a fleet of 3D printers, and material fabrication devices, the Mars crew expands the settlement. In the years following, dozens of humans will join the colony from Earth. Soon, other colonies will be built, and mankind will enter a new age of discovery and at last secure it's destiny in space.



## ***Phobos First***

### **Program Proposal for Robotics-Enabled Manned Space Exploration and Colonization**

We propose a comprehensive plan to establish the first human base on Mars well within the next century, using technology that is currently available or in research and development, and with minimal risk to human life.

Recently proposed manned space missions focus on returning to the moon or exploring asteroids. We focus on the “more worthy” goal of establishing a permanent human presence on the planet Mars. Unlike other Mars colonization scenarios, which send crews with their habitats directly to Mars, this scenario sends the habitat first, to be set up by robots on Mars, and only sends a human crew once the base is up and running. This robotic strategy eliminates risk to human life because we will know that the crew can survive on Mars before they ever leave earth. However, fully-autonomous robotic technologies capable of setting up an entire base on another planet are far off. We could operate the robots remotely from earth, but because of interplanetary time delay in control, this approach would take far too long, and be far more expensive.

Instead, we propose sending a smaller outpost to the Martian moon Phobos. This outpost will set itself up on Phobos autonomously, but because it’s one piece, no assembly is required, so this should be achievable. Once this outpost is established, a small human crew is sent to Phobos, while base modules and robots are sent to Mars. Over the course of a year, this Phobos crew remotely operates the robots on Mars to assemble and test the Mars base. When the Mars base is complete, the first colonists are sent to Mars, and the Phobos crew returns to Earth. (Getting off the tiny moon Phobos and returning to Earth is trivial compared to returning from the surface of Mars)

This scenario has the key advantage that robots do the “heavy lifting” in dangerous environments, making safe habitats before humans ever arrive, but at the same time it avoids the risks inherent to relying on fully-autonomous systems operating on another planet, and the high-cost and time of operating robots remotely from earth. All steps are doable with current technology or technology that is being researched, but this program would greatly accelerate the development of semi-autonomous robotics that is valuable to both the military and corporate sectors.

<b>Proposal Specification</b>	<b>Estimate</b>
Time Frame	2030s
Total Cost	\$20 Billion
Technological Outcomes	Dramatic Advances in semi-autonomous robotics and human-in-the-loop robotic operations

*Daniel Fitzgerald*  
*Steve Kordell*  
*Shawn Ferini*

Chief Mission Architect, NASA Headquarters, Washington DC  
Chief Scientist, NASA Jet Propulsion Laboratory, Pasadena, CA  
Chief Engineer, NASA Johnson Space Center, Houston, Texas

Your identification symbol



Please respond to the following questions with your initial reaction to the scenario presented.  
(*Out of character*)

**How likely is it that this scenario could come about?**

Unlikely                      Somewhat Unlikely                      Somewhat Likely                      Very Likely

**How valuable are investments in space exploration?**

Unvaluable                      SomeWhat Unvaluable                      Somewhat Valuable                      Very Valuable

**What technologies are required for human space exploration and colonization?**

current technology    technology currently in R&D    foreseeable technologies    unforeseeable

**When will manned space exploration beyond the moon or space colonization begin?**

within a decade                      within half a century                      within a century                      beyond a century

**Please Comment on the scenario** (if you had any trouble with the questions above, please note it here as well)

Your identification symbol



Please respond to the following questions on the scenario presented after questioning the presenters and discussing the proposal. (*In character*)

**How likely is it that this scenario could come about?**

Unlikely                      Somewhat Unlikely                      Somewhat Likely                      Very Likely

**How valuable is this investment in space exploration?**

Unvaluable                      SomeWhat Unvaluable                      Somewhat Valuable                      Very Valuable

**What technologies are required for this space exploration and colonization scenario?**

current technology      technology currently in R&D      foreseeable technologies      unforeseeable

**What is an appropriate time frame for the execution of this mission?**

within a decade                      within half a century                      within a century                      beyond a century

**Please Comment on the scenario** (if you had any trouble with the questions above, please note it here as well)

## Frequency Table

**Pre-discussion (out of character): How likely is it that this scenario could come about?**

	Frequency	Percent	Valid Percent	Cumulative Percent
Valid Unlikely	1	3.0	3.0	3.0
Somewhat Unlikely	5	15.2	15.2	18.2
Somewhat Likely	22	66.7	66.7	84.8
Very Likely	5	15.2	15.2	100.0
Total	33	100.0	100.0	

**Pre-discussion (out of character): How valuable are investments in space exploration?**

	Frequency	Percent	Valid Percent	Cumulative Percent
Valid Somewhat Unvaluable	6	18.2	18.2	18.2
Somewhat Valuable	6	18.2	18.2	36.4
Very Valuable	21	63.6	63.6	100.0
Total	33	100.0	100.0	

**Pre-discussion (out of character): What technologies are required for human space exploration and colonization?**

	Frequency	Percent	Valid Percent	Cumulative Percent
Valid Current Technology	1	3.0	3.0	3.0
Technology Currently in R&D	12	36.4	36.4	39.4
Foreseeable Technologies	14	42.4	42.4	81.8
Unforeseeable	6	18.2	18.2	100.0
Total	33	100.0	100.0	

**Pre-discussion (out of character): When will manned space exploration beyond the moon or space colonization begin?**

	Frequency	Percent	Valid Percent	Cumulative Percent
Valid Within a Decade	3	9.1	9.1	9.1
Within Half a Century	12	36.4	36.4	45.5
Within a Century	16	48.5	48.5	93.9
Beyond a Century	2	6.1	6.1	100.0
Total	33	100.0	100.0	

**Post-discussion (in character): How likely is it that this scenario could come about?**

	Frequency	Percent	Valid Percent	Cumulative Percent
Valid Unlikely	4	12.1	12.1	12.1
Somewhat Unlikely	7	21.2	21.2	33.3

**Post-discussion (in character): How likely is it that this scenario could come about?**

		Frequency	Percent	Valid Percent	Cumulative Percent
Valid	Somewhat Likely	17	51.5	51.5	84.8
	Very Likely	5	15.2	15.2	100.0
	Total	33	100.0	100.0	

**Post-discussion (in character): How valuable is this investment in space exploration?**

		Frequency	Percent	Valid Percent	Cumulative Percent
Valid	Unvaluable	2	6.1	6.1	6.1
	Somewhat Unvaluable	9	27.3	27.3	33.3
	Somewhat Valuable	12	36.4	36.4	69.7
	Very Valuable	10	30.3	30.3	100.0
	Total	33	100.0	100.0	

**Post-discussion (in character): What technologies are required for this space exploration project?**

		Frequency	Percent	Valid Percent	Cumulative Percent
Valid	Current Technology	1	3.0	3.0	3.0
	Technology Currently in R&D	10	30.3	30.3	33.3
	Foreseeable Technologies	15	45.5	45.5	78.8
	Unforeseeable	7	21.2	21.2	100.0
	Total	33	100.0	100.0	

**Post-discussion (in character): What is an appropriate time frame for the execution of this mission?**

		Frequency	Percent	Valid Percent	Cumulative Percent
Valid	Within a Decade	2	6.1	6.1	6.1
	Within Half a Century	11	33.3	33.3	39.4
	Within a Century	17	51.5	51.5	90.9
	Beyond a Century	3	9.1	9.1	100.0
	Total	33	100.0	100.0	

**Notes**

Input	Output Created	11-Mar-2014 14:05:55
	Comments	
	Data	M:\WPI\Junior\IQP\Mars STSDData\PhobosPlusBeau.sav
	Active Dataset	DataSet1
	Filter	<none>
	Weight	<none>
	Split File	<none>
	N of Rows in Working Data File	33
Missing Value Handling	Definition of Missing	User-defined missing values are treated as missing.
	Cases Used	Statistics for each pair of variables are based on all the cases with valid data for that pair.
	Syntax	NONPAR CORR /VARIABLES=s1_q1 s1_q2 s1_q3 s1_q4 s2_g1 s2_q2 s2_q3 s2_q4 Nasa_Likely Nasa_spin_off Nasa_Quality Nasa_Machine Nasa_Ethics /PRINT=SPEARMAN TWOTAIL NOSIG /MISSING=PAIRWISE.
Resources	Processor Time	0:00:00.016
	Elapsed Time	0:00:00.026
	Number of Cases Allowed	50737 cases <sup>a</sup>

a. Based on availability of workspace memory

**Correlations**

			Pre-discussion (out of character): How likely is it that this scenario could come about?	Pre-discussion (out of character): How valuable are investments in space exploration?
Spearman's rho	Pre-discussion (out of character): How likely is it that this scenario could come about?	Correlation Coefficient	1.000	-.008
		Sig. (2-tailed)	.	.963
		N	33	33
	Pre-discussion (out of character): How valuable are investments in space exploration?	Correlation Coefficient	-.008	1.000
		Sig. (2-tailed)	.963	.
		N	33	33

**Correlations**

			Pre-discussion (out of character): What technologies are required for human space exploration and colonization?	Pre-discussion (out of character): When will manned space exploration beyond the moon or space colonization begin?
Spearman's rho	Pre-discussion (out of character): How likely is it that this scenario could come about?	Correlation Coefficient Sig. (2-tailed) N	-.141 .435 33	-.227 .204 33
	Pre-discussion (out of character): How valuable are investments in space exploration?	Correlation Coefficient Sig. (2-tailed) N	-.175 .329 33	.177 .326 33

**Correlations**

			Post-discussion (in character): How likely is it that this scenario could come about?	Post-discussion (in character): How valuable is this investment in space exploration?
Spearman's rho	Pre-discussion (out of character): How likely is it that this scenario could come about?	Correlation Coefficient Sig. (2-tailed) N	.474 .005 33	-.185 .302 33
	Pre-discussion (out of character): How valuable are investments in space exploration?	Correlation Coefficient Sig. (2-tailed) N	.134 .456 33	.640 .000 33

\*\* . Correlation is significant at the 0.01 level (2-tailed).

**Correlations**

			Post-discussion (in character): What technologies are required for this space exploration project?	Post-discussion (in character): What is an appropriate time frame for the execution of this mission?
Spearman's rho	Pre-discussion (out of character): How likely is it that this scenario could come about?	Correlation Coefficient Sig. (2-tailed) N	-.327 .063 33	-.095 .599 33
	Pre-discussion (out of character): How valuable are investments in space exploration?	Correlation Coefficient Sig. (2-tailed) N	-.083 .646 33	.008 .966 33

**Correlations**

			How likely is it that this scenario could come about?	If the scenario came about, would the resulting technology be likely to spin-off many applications that significantly advance the field of robotics?
Spearman's rho	Pre-discussion (out of character): How likely is it that this scenario could come about?	Correlation Coefficient Sig. (2-tailed) N	.156 .386 33	-.047 .797 33
	Pre-discussion (out of character): How valuable are investments in space exploration?	Correlation Coefficient Sig. (2-tailed) N	-.172 .338 33	.002 .991 33



**Correlations**

			If the scenario came about, how desirable or undesirable would the resulting changes in quality of life be?	If the scenario came about, how desirable or undesirable would the resulting change in the man machine relationship be?
Spearman's rho	Pre-discussion (out of character): How likely is it that this scenario could come about?	Correlation Coefficient Sig. (2-tailed) N	-.037 .839 33	-.180 .317 33
	Pre-discussion (out of character): How valuable are investments in space exploration?	Correlation Coefficient Sig. (2-tailed) N	-.273 .124 33	.014 .938 33

**Correlations**

			If this scenario came about, how likely would it be to raise severe or challenging ethical concerns?
Spearman's rho	Pre-discussion (out of character): How likely is it that this scenario could come about?	Correlation Coefficient Sig. (2-tailed) N	-.155 .390 33
	Pre-discussion (out of character): How valuable are investments in space exploration?	Correlation Coefficient Sig. (2-tailed) N	.252 .158 33

### Correlations

			Pre-discussion (out of character): How likely is it that this scenario could come about?	Pre-discussion (out of character): How valuable are investments in space exploration?
Spearman's rho	Pre-discussion (out of character): What technologies are required for human space exploration and colonization?	Correlation Coefficient	-.141	-.175
		Sig. (2-tailed)	.435	.329
		N	33	33
	Pre-discussion (out of character): When will manned space exploration beyond the moon or space colonization begin?	Correlation Coefficient	-.227	.177
		Sig. (2-tailed)	.204	.326
		N	33	33
	Post-discussion (in character): How likely is it that this scenario could come about?	Correlation Coefficient	.474**	.134
		Sig. (2-tailed)	.005	.456
		N	33	33
Post-discussion (in character): How valuable is this investment in space exploration?	Correlation Coefficient	-.185	.640**	
	Sig. (2-tailed)	.302	.000	
	N	33	33	
Post-discussion (in character): What technologies are required for this space exploration project?	Correlation Coefficient	-.327	-.083	
	Sig. (2-tailed)	.063	.646	
	N	33	33	
Post-discussion (in character): What is an appropriate time frame for the execution of this mission?	Correlation Coefficient	-.095	.008	
	Sig. (2-tailed)	.599	.966	
	N	33	33	
How likely is it that this scenario could come about?	Correlation Coefficient	.156	-.172	
	Sig. (2-tailed)	.386	.338	
	N	33	33	
If the scenario came about, would the resulting technology be likely to spin-off many applications that significantly advance the field of robotics?	Correlation Coefficient	-.047	.002	
	Sig. (2-tailed)	.797	.991	
	N			

\*\* . Correlation is significant at the 0.01 level (2-tailed).

### Correlations

			Pre-discussion (out of character): What technologies are required for human space exploration and colonization?	Pre-discussion (out of character): When will manned space exploration beyond the moon or space colonization begin?
Spearman's rho	Pre-discussion (out of character): What technologies are required for human space exploration and colonization?	Correlation Coefficient	1.000	.090
		Sig. (2-tailed)	.	.618
		N	33	33
	Pre-discussion (out of character): When will manned space exploration beyond the moon or space colonization begin?	Correlation Coefficient	.090	1.000
		Sig. (2-tailed)	.618	.
		N	33	33
	Post-discussion (in character): How likely is it that this scenario could come about?	Correlation Coefficient	.046	.072
		Sig. (2-tailed)	.799	.690
		N	33	33
Post-discussion (in character): How valuable is this investment in space exploration?	Correlation Coefficient	.043	.078	
	Sig. (2-tailed)	.811	.666	
	N	33	33	
Post-discussion (in character): What technologies are required for this space exploration project?	Correlation Coefficient	.404	.177	
	Sig. (2-tailed)	.020	.323	
	N	33	33	
Post-discussion (in character): What is an appropriate time frame for the execution of this mission?	Correlation Coefficient	-.104	.570	
	Sig. (2-tailed)	.566	.001	
	N	33	33	
How likely is it that this scenario could come about?	Correlation Coefficient	-.051	.183	
	Sig. (2-tailed)	.778	.307	
	N	33	33	
If the scenario came about, would the resulting technology be likely to spin-off many applications that significantly advance the field of robotics?	Correlation Coefficient	.168	.024	
	Sig. (2-tailed)	.351	.892	

\*\* . Correlation is significant at the 0.01 level (2-tailed).

\* . Correlation is significant at the 0.05 level (2-tailed).

### Correlations

			Post-discussion (in character): How likely is it that this scenario could come about?	Post-discussion (in character): How valuable is this investment in space exploration?
Spearman's rho	Pre-discussion (out of character): What technologies are required for human space exploration and colonization?	Correlation Coefficient Sig. (2-tailed) N	.046 .799 33	.043 .811 33
	Pre-discussion (out of character): When will manned space exploration beyond the moon or space colonization begin?	Correlation Coefficient Sig. (2-tailed) N	.072 .690 33	.078 .666 33
	Post-discussion (in character): How likely is it that this scenario could come about?	Correlation Coefficient Sig. (2-tailed) N	1.000 . 33	.064 .722 33
	Post-discussion (in character): How valuable is this investment in space exploration?	Correlation Coefficient Sig. (2-tailed) N	.064 .722 33	1.000 . 33
	Post-discussion (in character): What technologies are required for this space exploration project?	Correlation Coefficient Sig. (2-tailed) N	-.233 .192 33	.145 .420 33
	Post-discussion (in character): What is an appropriate time frame for the execution of this mission?	Correlation Coefficient Sig. (2-tailed) N	-.414 .017 33	-.168 .351 33
	How likely is it that this scenario could come about?	Correlation Coefficient Sig. (2-tailed) N	.185 .302 33	-.036 .842 33
	If the scenario came about, would the resulting technology be likely to spin-off many applications that significantly advance the field of robotics?	Correlation Coefficient Sig. (2-tailed)	.028 .876	-.012 .945

\*. Correlation is significant at the 0.05 level (2-tailed).

### Correlations

			Post-discussion (in character): What technologies are required for this space exploration project?	Post-discussion (in character): What is an appropriate time frame for the execution of this mission?
Spearman's rho	Pre-discussion (out of character): What technologies are required for human space exploration and colonization?	Correlation Coefficient	.404	-.104
		Sig. (2-tailed)	.020	.566
		N	33	33
	Pre-discussion (out of character): When will manned space exploration beyond the moon or space colonization begin?	Correlation Coefficient	.177	.570
		Sig. (2-tailed)	.323	.001
		N	33	33
	Post-discussion (in character): How likely is it that this scenario could come about?	Correlation Coefficient	-.233	-.414
		Sig. (2-tailed)	.192	.017
		N	33	33
Post-discussion (in character): How valuable is this investment in space exploration?	Correlation Coefficient	.145	-.168	
	Sig. (2-tailed)	.420	.351	
	N	33	33	
Post-discussion (in character): What technologies are required for this space exploration project?	Correlation Coefficient	1.000	.313	
	Sig. (2-tailed)	.	.076	
	N	33	33	
Post-discussion (in character): What is an appropriate time frame for the execution of this mission?	Correlation Coefficient	.313	1.000	
	Sig. (2-tailed)	.076	.	
	N	33	33	
How likely is it that this scenario could come about?	Correlation Coefficient	-.147	.077	
	Sig. (2-tailed)	.414	.670	
	N	33	33	
If the scenario came about, would the resulting technology be likely to spin-off many applications that significantly advance the field of robotics?	Correlation Coefficient	.073	-.023	
	Sig. (2-tailed)	.685	.900	
	N			

\*\* . Correlation is significant at the 0.01 level (2-tailed).

\* . Correlation is significant at the 0.05 level (2-tailed).

**Correlations**

			How likely is it that this scenario could come about?	If the scenario came about, would the resulting technology be likely to spin-off many applications that significantly advance the field of robotics?
Spearman's rho	Pre-discussion (out of character): What technologies are required for human space exploration and colonization?	Correlation Coefficient	-.051	.168
		Sig. (2-tailed)	.778	.351
		N	33	33
	Pre-discussion (out of character): When will manned space exploration beyond the moon or space colonization begin?	Correlation Coefficient	.183	.024
		Sig. (2-tailed)	.307	.892
		N	33	33
	Post-discussion (in character): How likely is it that this scenario could come about?	Correlation Coefficient	.185	.028
		Sig. (2-tailed)	.302	.876
		N	33	33
Post-discussion (in character): How valuable is this investment in space exploration?	Correlation Coefficient	-.036	-.012	
	Sig. (2-tailed)	.842	.945	
	N	33	33	
Post-discussion (in character): What technologies are required for this space exploration project?	Correlation Coefficient	-.147	.073	
	Sig. (2-tailed)	.414	.685	
	N	33	33	
Post-discussion (in character): What is an appropriate time frame for the execution of this mission?	Correlation Coefficient	.077	-.023	
	Sig. (2-tailed)	.670	.900	
	N	33	33	
How likely is it that this scenario could come about?	Correlation Coefficient	1.000	.258	
	Sig. (2-tailed)	.	.146	
	N	33	33	
If the scenario came about, would the resulting technology be likely to spin-off many applications that significantly advance the field of robotics?	Correlation Coefficient	.258	1.000	
	Sig. (2-tailed)	.146	.	

### Correlations

			If the scenario came about, how desirable or undesirable would the resulting changes in quality of life be?	If the scenario came about, how desirable or undesirable would the resulting change in the man machine relationship be?
Spearman's rho	Pre-discussion (out of character): What technologies are required for human space exploration and colonization?	Correlation Coefficient	-.157	-.069
		Sig. (2-tailed)	.384	.703
		N	33	33
	Pre-discussion (out of character): When will manned space exploration beyond the moon or space colonization begin?	Correlation Coefficient	.034	-.099
		Sig. (2-tailed)	.851	.584
		N	33	33
	Post-discussion (in character): How likely is it that this scenario could come about?	Correlation Coefficient	.161	-.216
		Sig. (2-tailed)	.370	.227
		N	33	33
	Post-discussion (in character): How valuable is this investment in space exploration?	Correlation Coefficient	.014	.189
Sig. (2-tailed)		.939	.291	
N		33	33	
Post-discussion (in character): What technologies are required for this space exploration project?	Correlation Coefficient	.225	.381	
	Sig. (2-tailed)	.208	.029	
	N	33	33	
Post-discussion (in character): What is an appropriate time frame for the execution of this mission?	Correlation Coefficient	-.040	.145	
	Sig. (2-tailed)	.825	.422	
	N	33	33	
How likely is it that this scenario could come about?	Correlation Coefficient	.215	.086	
	Sig. (2-tailed)	.230	.633	
	N	33	33	
If the scenario came about, would the resulting technology be likely to spin-off many applications that significantly advance the field of robotics?	Correlation Coefficient	.098	.116	
	Sig. (2-tailed)	.588	.520	

\*. Correlation is significant at the 0.05 level (2-tailed).

### Correlations

			If this scenario came about, how likely would it be to raise severe or challenging ethical concerns?
Spearman's rho	Pre-discussion (out of character): What technologies are required for human space exploration and colonization?	Correlation Coefficient	.292
		Sig. (2-tailed)	.100
		N	33
	Pre-discussion (out of character): When will manned space exploration beyond the moon or space colonization begin?	Correlation Coefficient	.027
		Sig. (2-tailed)	.879
		N	33
	Post-discussion (in character): How likely is it that this scenario could come about?	Correlation Coefficient	-.029
		Sig. (2-tailed)	.873
		N	33
	Post-discussion (in character): How valuable is this investment in space exploration?	Correlation Coefficient	.224
Sig. (2-tailed)		.210	
N		33	
Post-discussion (in character): What technologies are required for this space exploration project?	Correlation Coefficient	-.043	
	Sig. (2-tailed)	.811	
	N	33	
Post-discussion (in character): What is an appropriate time frame for the execution of this mission?	Correlation Coefficient	-.048	
	Sig. (2-tailed)	.790	
	N	33	
How likely is it that this scenario could come about?	Correlation Coefficient	-.061	
	Sig. (2-tailed)	.737	
	N	33	
If the scenario came about, would the resulting technology be likely to spin-off many applications that significantly advance the field of robotics?	Correlation Coefficient	.246	
	Sig. (2-tailed)	.167	



**Correlations**

			Pre-discussion (out of character): How likely is it that this scenario could come about?	Pre-discussion (out of character): How valuable are investments in space exploration?
Spearman's rho	If the scenario came about, would the resulting technology be likely to spin-off many applications that significantly advance the field of robotics?	N	33	33
	If the scenario came about, how desirable or undesirable would the resulting changes in quality of life be?	Correlation Coefficient Sig. (2-tailed) N	-.037 .839 33	-.273 .124 33
	If the scenario came about, how desirable or undesirable would the resulting change in the man machine relationship be?	Correlation Coefficient Sig. (2-tailed) N	-.180 .317 33	.014 .938 33
	If this scenario came about, how likely would it be to raise severe or challenging ethical concerns?	Correlation Coefficient Sig. (2-tailed) N	-.155 .390 33	.252 .158 33

**Correlations**

			Pre-discussion (out of character): What technologies are required for human space exploration and colonization?	Pre-discussion (out of character): When will manned space exploration beyond the moon or space colonization begin?
Spearman's rho	If the scenario came about, would the resulting technology be likely to spin-off many applications that significantly advance the field of robotics?	N	33	33
	If the scenario came about, how desirable or undesirable would the resulting changes in quality of life be?	Correlation Coefficient Sig. (2-tailed) N	-.157 .384 33	.034 .851 33
	If the scenario came about, how desirable or undesirable would the resulting change in the man machine relationship be?	Correlation Coefficient Sig. (2-tailed) N	-.069 .703 33	-.099 .584 33
	If this scenario came about, how likely would it be to raise severe or challenging ethical concerns?	Correlation Coefficient Sig. (2-tailed) N	.292 .100 33	.027 .879 33

**Correlations**

			Post-discussion (in character): How likely is it that this scenario could come about?	Post-discussion (in character): How valuable is this investment in space exploration?
Spearman's rho	If the scenario came about, would the resulting technology be likely to spin-off many applications that significantly advance the field of robotics?	N	33	33
	If the scenario came about, how desirable or undesirable would the resulting changes in quality of life be?	Correlation Coefficient Sig. (2-tailed) N	.161 .370 33	.014 .939 33
	If the scenario came about, how desirable or undesirable would the resulting change in the man machine relationship be?	Correlation Coefficient Sig. (2-tailed) N	-.216 .227 33	.189 .291 33
	If this scenario came about, how likely would it be to raise severe or challenging ethical concerns?	Correlation Coefficient Sig. (2-tailed) N	-.029 .873 33	.224 .210 33