



# WPI

By

Alp Piskin

Maricella Ramirez

Michael MacCormac

Quincy Rhodes

## **Improving Sustainability Index at Universidad Tecnológica de Panamá**

Sponsor: Facultad de Ingeniería Eléctrica - Universidad Tecnológica de Panamá



# Improving Sustainability Index at Universidad Tecnológica de Panamá

An Interactive Qualifying Project Submitted to the Faculty of WORCESTER  
POLYTECHNIC INSTITUTE In partial fulfilment of the requirements for the Degree of  
Bachelor of Science

By

Alp Piskin

Maricella Ramirez

Michael MacCormac

Quincy Rhodes

Date: October 12, 2018

Report Submitted to: PROFESSOR JAMES CHIARELLI, Jefferson Alex Sphar  
ADVISOR Worcester Polytechnic Institute

*This report represents work of WPI undergraduate students submitted to the faculty as evidence of a degree requirement. WPI routinely publishes these reports on its web site without editorial or peer review. For more information about the projects program at WPI, see <http://www.wpi.edu/Academics/Projects>.*

## ABSTRACT

Universidad Tecnológica de Panama (UTP) seeks to create a greener campus. The goal of this project was to create an initial implementation for an air quality measuring system and to document students' sustainability awareness using a survey. Information gathered from the surveys and interviews was used to determine shortcomings in energy savings and an air quality monitoring module prototype was built. UTP will have a blueprint to work from to reproduce their own air quality modules and create a network on all their campuses. Recommendations were also be provided including a control system to be implemented for classroom lights and sustainability events to be developed to increase student awareness. Due to the findings and the analysis, the recommended steps along with the projects planned by UTP's Department of Energy Savings would increase sustainability on UTP campus.

## ACKNOWLEDGEMENTS

We would like to thank our project site advisors, James Chiarelli and Alex Sphar, for providing us the opportunity to work on this project, and our sponsors Maytee Zambrano and Guadalupe Gonzalez, for guiding us and providing the resources we need, as well as Josue Rodriquez for his invaluable assistance on the project.

## EXECUTIVE SUMMARY

Universidad Tecnológica de Panama (UTP) is the oldest engineering college in Panama, despite this the sustainability initiatives at UTP have only been implemented within the last decade. In recent years Panama has grown much due to its economy but one major concern among engineers is the toll of inefficient systems on the environment for future students & faculty. UTP is lacking in many key areas of sustainability such as power efficient appliances, waste management, and water conservation. The Department of Electrical Engineering and Department of Energy Savings have been working to resolve these issues. The International university sustainability index, GreenMetric is one of the methods UTP is using in an effort to make a greener campus. This sustainability index allows UTP to report their progress, receive a score, then adjust or continue their plans based on how well they scored. The goal of this project is to help UTP take steps towards improving their GreenMetric score, in turn becoming a more sustainable campus.

The Energy & Climate Change section of the GreenMetric is the heaviest weighted category in the GreenMetric. Thus, this category will be the focus of this project. A part of the Energy and Climate Change category asks for CO<sub>2</sub> emission calculations and a greenhouse gas reduction program. To aid in implementing these two sub-goals, an air quality monitoring system was started. To aid in determining energy efficient equipment and practices as well as calculating carbon footprint, staff interviews and student surveys were carried out.

The air quality monitoring process resulted in a functioning prototype for future modules. A student survey gave insight into energy use and sustainability awareness. A staff interview resulted in gaining knowledge of the Department of Energy Saving's involvement in increasing sustainability on UTP campus.

The projected resulted in UTP receiving a blueprint to reproduce air quality modules and create a network on all their campuses. Sustainability events provided through UTP should be developed and advertised to increase student involvement and awareness. These steps along with the Department of Energy Savings' projects would increase UTP's GreenMetric score and overall campus sustainability.

## AUTHORSHIP

Introduction	Michael
Background	
Environmental Sustainability	Maricella
Sustainability in Panama	Quincy
Sustainability Indexes	Maricella
GreenMetric	Quincy
Greenhouse Gas Reduction Program	Alp & Quincy
Universidad Tecnológica de Panama	Maricella & Quincy
UTP's Sustainability Projects	Maricella
Role of Universities in Leading Sustainability Practices	Alp
Electricity Production in Panama	Michael
Monitoring Energy Consumption on Campus	Alp
Monitoring Air Quality on Campus	Alp & Quincy
Methodology	
Objectives	Alp
Determining Methods	Alp
Data to be Collected	Alp
Air Quality Monitoring	Alp & Quincy
Findings	
Energy and Climate Change	Alp
Survey Results	Maricella
Student Sustainability Practices	Maricella
Student Sustainability Awareness	Maricella
Conclusion and Recommendations	Alp
GreenMetric Projection	Alp
Air Quality Monitoring Recommendations	Quincy & Maricella
Energy Recommendations	Maricella
Sustainability Awareness Recommendations	Maricella
Future Project Recommendations	Maricella & Alp
Lead Reviewer	Michael

## TABLE OF CONTENTS

Abstract .....	ii
Acknowledgements .....	iii
Executive Summary .....	iv
Authorship .....	v
Table of Contents .....	vi
Table of Figures .....	viii
Introduction.....	1
Background.....	3
Environmental Sustainability .....	3
Sustainability in Panama.....	3
Sustainability Indexes .....	4
GreenMetric .....	4
Universidad Tecnológica de Panama .....	5
UTP’s Sustainability Projects.....	5
Role of Universities in leading sustainability Practices.....	6
Yale University .....	6
University of Copenhagen.....	6
ETH Zurich .....	7
Worcester Polytechnic Institute .....	7
Electricity Production in Panama.....	9
Monitoring Energy Consumption on Campus.....	9
Monitoring Air Quality on Campus .....	9
Methodology.....	11
Objectives .....	11
Determining Methods .....	12
Air Quality .....	12
Energy .....	15
Findings .....	16
Air Quality.....	16
Survey Results.....	18
Student Sustainability Practices.....	18
Student Sustainability Awareness.....	19
Conclusion and Recommendations .....	21
GreenMetric Projection .....	22
Air Quality Monitoring Recommendations.....	22

---

Energy Recommendations .....	23
Sustainability Awareness Recommendations .....	24
Future Project Recommendations .....	24
Bibliography.....	26
Appendices .....	28
Appendix A: Breakdown of the GreenMetric 2016 Ranking System (UI GreenMetric, 2017) .....	28
Appendix B: Code Sample for Sensor Node.....	31
Appendix C: Code Sample for ESP32 .....	35
Appendix D: Survey In Spanish .....	37
Appendix E: Survey Results (translated to English) .....	42
Appendix F: Readme .....	54



## TABLE OF FIGURES

Figure 1: Energy Sustainability .....	1
Figure 2: WPI plans regarding sustainability (WPI, n.d.) .....	8
Figure 3: Sample MQ-135 Sensor .....	10
Figure 4: "LIBELIUM WASPMOTE - PLUG & SENSE!" .....	13
Figure 5: A rough circuit diagram of the replacement Arduino system with the sensors.....	14
Figure 6: ILLUSTRATED BLOCK DIAGRAM OF SENSOR NETWORK .....	15
Figure 7: SAMPLE ARDUINO SENSOR DATA .....	17
Figure 8: Sample section of data spreadsheet. columns (left to right): timestamp, temperature in degrees Celsius, humidity percent, particulate matter, co <sub>2</sub> in ppm.....	17
Figure 9: Percentage Of Students Who Turn Off The Lights .....	19
Figure 10: Student Methods Of Transportation .....	19
Figure 11: Student familiarity of UTP Sustainability events .....	20
Figure 12: Total cost of Air Quality Monitoring Module .....	22

## INTRODUCTION

The tropical country of Panama occupies the isthmus that connects the continents of North and South America, separating two great oceans. With the upgraded Panama Canal linking the Atlantic and Pacific oceans, Panama has enhanced its position as a critical shipping hub for world commerce. Yet as a tropical nation with pristine rain forests, Panama is also the home for its diverse community of plant and animal life derived from both continents. Recognizing the significance of the nation's natural environment, Panama has set aside one-sixth of the land area for national parks and reserves (Gustavo Anguizola, 2018).

Building on the tradition of responsible growth for the region, Panama now promotes sustainable or “green” lifestyles. The Universidad Tecnológica de Panama (UTP)—Panama’s premier educational institution for engineering, science and technology—endeavors to uphold these “green” principles. The university has adopted the mission of developing skilled and socially responsible professionals committed to sustainable progress with a low environmental impact (Department of international affairs, 2016). As a result, UTP has become a model for all other Panamanian schools and communities. Using the GreenMetric initiative as its guide, the university strives to improve its own sustainability metrics. Of the 619 universities participating in the GreenMetric initiative, UTP ranked 536<sup>th</sup> overall. Focusing on just the metric of Energy and Climate Change, UTP improves its ranking to 427<sup>th</sup> but it still falls within the bottom third of the rankings. With the Energy and Climate Change (EC) metric contributing the highest weighting in this ranking of 21%, the university could benefit from an electrical energy audit. This electrical energy sustainability audit would not only evaluate the total energy consumption but would also consider patterns of use and the implications of Panama’s tropical climate in order to eliminate wasteful electrical use and identify opportunities to improve efficiency. (UI GreenMetric, 2017)

The project would collect empirical data on actual air quality measurements from an Arduino based sensor unit. An on-campus survey would be conducted to understand and evaluate the students' sustainability knowledge.

## Energy Sustainability

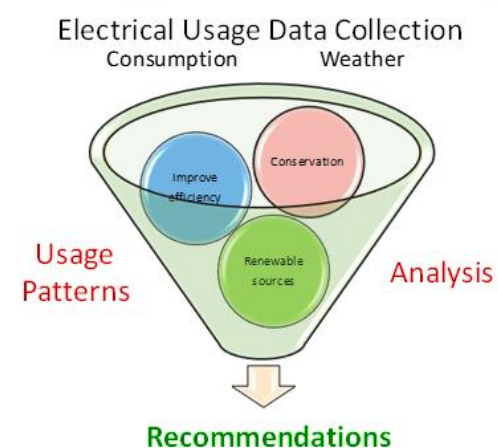

FIGURE 1: ENERGY SUSTAINABILITY

---

After collecting electrical consumption and environmental data, the data will be analyzed to uncover opportunities to improve electrical efficiency and to further implement a greenhouse reduction program. Solutions will be proposed in the form of recommendations ranked by a preliminary cost/benefit analysis. It would be expected that UTP would consider these recommendations in the university's long-range plans to engage in the development of best practices and lead the region as a model for environmental sustainability.

## BACKGROUND

### ENVIRONMENTAL SUSTAINABILITY

According to the United States Environmental Protection Agency (EPA), “Sustainability is...to create and maintain the conditions under which humans and nature can exist in productive harmony to support present and future generations” (EPA, 2016). Due to the complexities of modern society, there are numerous aspects to sustainability. An example would be Food Sustainability. It is necessary to properly feed everyone while also maintaining ethical treatment of the environment, animals, and other people. On the other hand, society does not necessarily need electricity to survive, but relies on it for everything from life-saving technology to entertainment. Electricity is produced through burning fossil fuels, which releases carbon dioxide (a greenhouse gas) causing the Earth’s atmosphere to rise in temperature. Therefore, Energy Sustainability is needed to make sure there is enough electricity to remain productive while also keeping the Earth’s atmosphere at a natural temperature. Food and electricity are only fractions of what society needs yet they must be mass produced in a way that avoids compromising the planet. Despite sustainability being key to human survival, as an issue it often remains overlooked by many governments of the world. Panama has made efforts to increase environmental awareness and is quickly becoming one of the greenest countries in Latin America.

### SUSTAINABILITY IN PANAMA

In 2009, the Panama Bay and City Water Sanitation Project began to introduce a modern water/waste sanitation system into Panama City's infrastructure. The project plans to feature three biological nutrient removal wastewater treatment plants. The first plant opened in 2013, as the first secondary water treatment facility in Central America. In addition to collecting wastewater discharges in the Panama City watershed, the plant also collects methane gas to help provide for the plant's electricity and heating needs. The facility has been described as one of the most advanced wastewater treatment systems in Latin America. (Burger, 2014)

Despite being the smallest country in Central America, Panama boasts the region’s second largest economy behind Mexico with the highest per capita income. Not only is Panama the home of the Panama Canal but Panama City, its capital, is a thriving metropolis. Yet Panama has not escaped the challenges and problems associated with a rapidly growing population and economy. Pressure on the environment, aggravated by threats from global warming, has spurred real investments in urban environmental sustainability. (Burger, 2014)

## SUSTAINABILITY INDEXES

With increasing concern about the sustainability of our environmental practices, universities around the globe have collaborated to promote sustainability-focused education and policy. Sustainability indexes are generally established and promoted by not-for-profit organizations that provide metrics to evaluate the sustainability practices based upon certain specific criteria. Such indices rank those who register, and the rankings are usually released through a publication to document improvement across the board as well as on individual levels. Each university involved adopts plans to improve the environmental sustainability by implementing programs to safeguard the environment, develop sustainable energy, reduce water consumption and waste, decrease their carbon footprint and promote the educational development of environmentally concerned students (Matthews, 2017). The sustainability index of choice for our sponsors at Universidad Tecnológica de Panama is the GreenMetric.

## GREENMETRIC

The GreenMetric was launched in 2010 by the University of Indonesia as a way of ranking universities around the world based on sustainability. UI GreenMetric was established in hopes that it would draw the attention of global university leaders to focus on conservation and combating climate change. The GreenMetric uses a set of criteria set forth in an online survey in order to determine a university's world ranking. The survey is organized in various sections, each one counting for a different part of the total score. (UI GreenMetric, 2017) These sections are:

- Setting and Infrastructure:
  - Guides the university to provide more space for greenery and in safeguarding environment, as well as developing sustainable energy
- Energy and Climate Change:
  - The university is expected to focus on the energy use of their campus and how that energy impacts the environment.
- Waste:
  - A university can produce a lot of waste, and this section places emphasis on the campus's waste and recycling programs.
- Transportation:
  - Focuses on carbon emissions produced by traffic on the campus and efforts to reduce these emissions
- Education:
  - This evaluates how well the university is training the next generation of environmentally concerned individuals.

The full breakdown of each section can be found in appendix A.

## Greenhouse Gas Reduction Program

One of the most significant subsections of the Energy and Climate Change part of the GreenMetric pertains to greenhouse gases along with any efforts to reduce the amount of greenhouse gases produced (UI GreenMetric, 2017).

Greenhouse gases are one of the major factors of climate change. The monitoring and reduction of greenhouse gases is heavily rewarded by the GreenMetric. In order to increase their GreenMetric score, universities must show an improvement in reducing the presence of greenhouse gases on campus. The universities first step is the implementation of a system to quantitatively measure greenhouse gases before any greenhouse gas reduction programs are implemented. It is beneficial to the university to have yearly submissions for a longer duration and show an increasing trend in the respective GreenMetric score rather than not submit anything at all. Universidad Tecnológica de Panama has no such program and implementing a system to measure greenhouse gases would benefit its GreenMetric score.

## UNIVERSIDAD TECNOLÓGICA DE PANAMA

Formerly the Engineering School of the University of Panama, UTP became an independent institution in 1984 and is the second largest university in Panama. Since then, it has produced more than 43,000 professionals through higher education. Currently, UTP offers 43 advanced careers, 28 bachelor's degrees, 21 technical careers. The university employs over two thousand professors and administrative staff along with about 18,000 currently enrolled students at both graduate and under-graduate levels. The university is a valuable resource for Panama, contributing greatly to the technological development of the country.

UTP has seven different campuses housing six different faculties. The main campus, which served as our project site, is located in Panama City next to undeveloped forest. extensive efforts have been made to minimize the university's impact on the surrounding environment. One of the main concerns is the air quality on campus, negatively affected by the surrounding city. Vehicle emissions from nearby traffic, construction, and landfill incinerators are a few examples of local factors that increase air pollution. (Dworak, MacLeod, Mears, & Wernsing, 2017) Being a leader of technological advancement in the community, UTP has a responsibility to promote environmentally sustainable practices.

## UTP'S SUSTAINABILITY PROJECTS

Universidad Tecnológica de Panamá has a department dedicated to replacing inefficient infrastructure and install renewable energy sources to make the campus more sustainable. UTP's first buildings were constructed in 1980's and have been remodeled over the years to accommodate more students & faculty. Because sustainability was not integrated into the design of these buildings, it has become more and more difficult to implement features such as efficient HVAC systems, solar panels, and other electrical components which help save energy. Despite this

hurdle the Department of Energy Savings at UTP is targeting the most crucial areas that can be improved and are developing plans, some of which have already been implemented.

One of the first changes made on the campus in 2017, was the replacement of old inefficient bulbs to LEDs in outdoor public spaces. Concerning Building 1, the energy saving team has developed plans and received funding for three major projects towards energy reduction. The first is a control system for the air handlers, installing Variable Frequency Drives (VFD) in the ductwork to allow temperature control in all spaces. The second is to replace 3,000 light fixtures in the building with LED fixtures. The final is to install surge protectors for all electronic devices in the building. This project is significant more from a safety & cost perspective as the surge protectors would defend against devices being damaged from power spikes which are frequent in Panama's rainy weather.

The three new buildings and parking lot being constructed at UTP are being designed to be sustainable from the start. These buildings will share a single efficient air conditioning chiller, and all have solar panels installed on the roofs. One other project not yet in the planning phase is about implementing a sensor based light control in every classroom. This idea is based on one student project which has successfully been implemented in two classrooms in Building 1.

## ROLE OF UNIVERSITIES IN LEADING SUSTAINABILITY PRACTICES

Numerous universities have initiatives and policies governing sustainability. Most initiatives are organized and operated by sustainability offices in these universities. Although each university has a different approach on what to prioritize in its sustainability plans, the set of objectives and plans are usually similar to that of other universities. This allows campuses with similar conditions to be compared to similar examples. With more universities involved, this type of thought exchange creates the environment for likes of the GreenMetric sustainability index. Therefore, it is useful for UTP to refer to universities with leading sustainability practices since it is also a goal set by sustainability indexes.

### YALE UNIVERSITY

Yale University is currently running two main initiatives to ensure sustainability around its campus. The first initiative targets training the core staff to align their daily routine with environmentally friendly practices. The second initiative aims at performing energy audits and at benchmarking energy use among the buildings.

### UNIVERSITY OF COPENHAGEN

The board of University of Copenhagen established a Green Campus Office in 2008. According to the director, the office has helped in establishing regulations that have reduced the energy consumption per person by 20 percent and the carbon emissions by 30 percent since 2006 (Mellino, 2014). The buildings were improved by replacing the ventilation units and installing LED lights.

#### ETH ZURICH

In the planning, construction, and operation of the buildings, ETH Zurich has implemented a set of principles that regulated the eco-friendliness of the buildings. For the planning and construction, it performs a life-cycle cost analysis to ensure sustainability. For the operation section, the university is running a large project that involves making an underground heating/storage system to make the heating mechanism of the campus carbon-neutral (Mellino, 2014).

#### WORCESTER POLYTECHNIC INSTITUTE

WPI has released a Sustainability brochure that talks about the universities plans regarding sustainability. The overall plan consists of four main goals: Academics; Campus Operation; Research and Scholarship; and Community Engagement. Figure 2 shows a table for WPI's Campus Operation plans.



Objective/Task	Measures for Progress	Target Begin/Complete <sup>1</sup>	Responsible Parties
<b>Objective:</b> Utility consumption is reduced by 25% over 5 years	<ul style="list-style-type: none"> <li>* Electricity consumption (kWh/year/person)</li> <li>* Heating per capita (BTUs &amp; therms/year/person)</li> <li>* Water consumption per capita (gallons/year/person)</li> </ul>	FY14/FY18	Facilities
<b>Objective:</b> In addition to new construction, all major building renovations on campus are LEED-certifiable	<ul style="list-style-type: none"> <li>* New construction LEED-certifiable</li> <li>* Renovations LEED-certifiable</li> </ul>	FY15/ongoing	Director of Sustainability, Facilities
<b>Objective:</b> The amount of campus waste disposed of in landfills or incinerators on a per capita basis is reduced to 10% below the national average	<ul style="list-style-type: none"> <li>* National average</li> <li>* Pounds or tons of waste/year/person</li> </ul>	FY14/FY18	Director of Sustainability, Facilities
<b>Task:</b> Define building usage and assess building schedules to efficiently manage heating and cooling	<ul style="list-style-type: none"> <li>* Policies and schedules developed and implemented</li> </ul>	FY14/FY15	Director of Sustainability, Facilities
<b>Task:</b> Invest in energy programs (focus on deferred maintenance with support from utility incentives)	<ul style="list-style-type: none"> <li>* Amount of funds (\$) invested in energy programs on an annual basis</li> </ul>	FY15/ongoing	Director of Sustainability, Facilities
<b>Task:</b> Establish a green revolving fund	<ul style="list-style-type: none"> <li>* Revolving fund and associated procedures established</li> <li>* Amount of money (\$) available through the fund</li> </ul>	FY15	Finance & Operations, Facilities, Director of Sustainability
<b>Task:</b> Monitor energy use real-time with submetering	<ul style="list-style-type: none"> <li>* Energy use monitored real-time with submetering</li> </ul>	FY16/ongoing	Facilities
<b>Task:</b> Increase sustainability in computing by using sustainable principles in the purchasing and operation of data centers, and through community education and awareness programs.	<ul style="list-style-type: none"> <li>* Energy savings (kWh ) associated with computer use</li> <li>* Number of participants in sustainable computing programs</li> <li>* Computer recycling</li> </ul>	FY15/ongoing	IT, Director of Sustainability
<b>Task:</b> Evaluate how recycling and trash pick-up is managed, including disposal contractors and research opportunities	<ul style="list-style-type: none"> <li>* Comprehensive waste/recycling audit (with suggested solutions) complete</li> </ul>	FY14	Facilities
<b>Task:</b> Improve campus recycling infrastructure by purchasing and installing user-friendly recycling containers and adding solar compactors to campus outdoor trash receptacles	<ul style="list-style-type: none"> <li>* Number of recycling containers purchased and installed</li> <li>* Number of solar compactors added to campus outside trash receptacles (compared to number of outside trash receptacles total)</li> </ul>	FY15	Facilities, Director of Sustainability
<b>Task:</b> Develop a marketing campaign to tell the story of recycling at WPI	<ul style="list-style-type: none"> <li>* Marketing campaign for recycling developed and implemented</li> <li>* Campus culture and knowledge of recycling</li> <li>* Pounds or tons of recycling/year/person</li> </ul>	FY15	Director of Sustainability, Marketing and Communications
<b>Task:</b> Eliminate disposable/single-use plastic water bottles from the campus	<ul style="list-style-type: none"> <li>* Number of disposable/single-use plastic water bottles bought/sold on campus</li> </ul>	FY15	Director of Sustainability, Facilities, Chartwells
<b>Task:</b> Install water bottle filling stations on the campus	<ul style="list-style-type: none"> <li>* Number of filling stations installed</li> <li>* Number of people using filling stations</li> </ul>	FY15	Director of Sustainability, Facilities, Chartwells
<b>Task:</b> Develop and implement purchasing guidelines to select products manufactured, packaged, and distributed in sustainable manners, and/or are made from recycled goods	<ul style="list-style-type: none"> <li>* Guidelines developed and published</li> <li>* Amount (\$) spent on green products compared to amount spent on non-green products</li> </ul>	FY15	Director of Sustainability, Purchasing, Departments
<b>Task:</b> Measure GHG emissions and report Scope 1 and 2 emissions annually	<ul style="list-style-type: none"> <li>* Greenhouse gas emissions measured annually</li> <li>* Scope 1 and 2 emissions reported annually</li> </ul>	FY14/ongoing	Director of Sustainability, Facilities
<b>Task:</b> Establish a methodology and timeline for reducing GHG emissions	<ul style="list-style-type: none"> <li>* GHG reduction target set</li> <li>* Method and timeline established</li> </ul>	FY14/FY15	Director of Sustainability, Facilities, community

<sup>1</sup>FY refers to the fiscal year. For example, FY14 refers to the fiscal year beginning July 1, 2013, and ending June 30, 2014, and encompasses the academic year.

FIGURE 2: WPI PLANS REGARDING SUSTAINABILITY (WPI, N.D.)

## ELECTRICITY PRODUCTION IN PANAMA

With electrical demand growing by 50 MW per year, Panama relies heavily on hydroelectric power generation during the rainy season, supplementing with traditional thermoelectric generation only during the dry season. Even with demand projected to outstrip supply, the Panamanian government is committed to using 70–80% renewable sources for generating electrical power, recently investing a billion dollars in solar and other clean energy projects (export.gov, 2016); (POLIS Attorneys, 2015). UTP is a government-funded university so the school board and the projects presented by the board usually have parallel objectives towards energy to those of the Panamanian government. In order to determine the effectiveness of clean energy and energy saving practices, energy monitoring is essential. This is also why the Department of Energy Savings has directed large amounts of focus to installing solar panels in old and new buildings. Many GreenMetric universities use energy monitoring to assess the data and analyze the effects of their sustainability efforts.

## MONITORING ENERGY CONSUMPTION ON CAMPUS

Some colleges such as Prescott College have a real-time 24-hour monitoring system of each building linked to a webpage. This allows anyone to easily access a graph and comparisons of energy usage day to day. The graphs show a comparison between a typical curve of electricity used over time to the actual electricity being used (Prescott College, 2017). A more rudimentary approach is to go building to building and record the energy usage from a meter on a regular interval. This method is time consuming and depending on the meters installed, may be inaccurate (O'Hara, Hobson-Dupont, Hurgin, & Thierry, 2007).

An optimal system for monitoring building energy usage would involve a three-tier system with the following tiers: collection; network communication; and data management (Zhong Bocheng, 2012). The collection tier consists of the various types of instrumentation used to monitor energy consumption such as power meters or temperature sensors. The network communication tier provides a means of transferring data from the collection tier to data management. The data management tier stores the transferred data, as well as giving a way to view the data for analysis. While energy monitoring is essential in fulfilling a high GreenMetric score in the Energy and Climate section, monitoring air quality is very important to the GreenMetric as well.

## MONITORING AIR QUALITY ON CAMPUS

Colleges that rank higher on sustainability indices typically aim to measure gases such as carbon dioxide (CO<sub>2</sub>), carbon monoxide (CO), ozone (O<sub>3</sub>), various sulfides, methane (CH<sub>4</sub>), and particulate matter (PM) on campus. For detecting most of these gases, there are a few options available that are both available on the market and compatible to be implemented with a microcontroller. Regarding carbon dioxide, the critical part about finding the right sensor was the accuracy of the sensor in air because most of the available carbon dioxide sensors did not have the capability to detect amounts below 1000 ppm although carbon dioxide concentrations outdoors usually do not go above about 600 ppm. (Air Test Technologies) A viable choice for this purpose was an infrared sensor called SKU:SEN0219. The best candidate for other sensors is the MQ series of sensors, produced by Hanwei Electronics. The MQ series can detect a wide range of air pollutants that include the gases mentioned above. A typical MQ sensor, shown in Figure 3, is thin and around the size of a small USB stick.



**FIGURE 3: SAMPLE MQ-135 SENSOR**

## METHODOLOGY

This project's purpose was to assist in the betterment of sustainability practices on UTP campus. The Electrical Engineering Department wanted to further implement an air quality monitoring system as well as determine other gaps in UTP's current practices for further improvement. These improvements would become apparent with an increase of UTP's GreenMetric score. To achieve this goal, the project was structured so that our team could help energy conservation, air quality and sustainability awareness in separate ways.

### OBJECTIVES

The following is a list of the objectives that were set to accomplish the purpose of this project:

1. Create a functioning prototype for monitoring the air quality to test its feasibility & establish an initial system that UTP can grow to monitor entire campuses
2. Provide recommendations on how UTP can improve their student body's interest in sustainability
3. Provide recommendations on how UTP can increase energy savings with the current state of conditions

For air quality, UTP was in a state of need for replacement air quality monitoring devices. With no data on substance concentrations in air, UTP would not be able to submit anything to GreenMetric and would receive a zero for that category. In our initial meeting, the UTP staff with whom we were working explicitly stated that they wished to discontinue use of the outdated devices they had been using in the past. The staff had also mentioned that they were unable to get these modules working properly so they did not even know if the readings they were getting were accurate. Therefore, our initial goal was to find or build a replacement for Libelium Plug & Sense modules with more reliable sensors. Based off the recommendation from last year and our research, our team decided to go ahead and build a module of our own based off an Arduino board. This would allow us to have multiple sensors attached to while keeping costs low. We prioritized receiving the deserved points by setting up the system first rather than working on offering guidelines because in the absence of data, we would have no precedent for guidelines.

The university already had reliable energy monitoring methods. As a result, our team was able to focus on providing guidelines and recommendations to improve the score. In the GreenMetric criteria total energy consumption and energy consumption per student carry significant weight. Due to this we focused on potential practices and guidelines to reduce the excess consumption. Through our research, we found a type of certification for energy conservation called Energy Star. Similar to the GreenMetric, Energy Star provides energy conservation recommendations for both students and staff. Our approach towards receiving data was to have corresponding

methods for students and staff. For students, a large portion of their role in energy conservation on campus centers around awareness. For the staff, it is mostly the staff's responsibility to maintain and reduce the energy consumption of electrical devices, which gives them a larger technical role.

At the end of analyzing both subsections, we were aiming to receive accurate data for energy and air quality to provide a set of guidelines on how to be more sustainable in both disciplines so that the GreenMetric score can be improved in succeeding years.

## DETERMINING METHODS

UTP aims to become a sustainability role model for other organizations and administrations in Panama. This is the reason why UTP faculty working in collaboration with last year's WPI IQP team has adopted a sustainability index (GreenMetric) as a path toward improving or creating sustainability practices on campus. According to Dworak et. al, UTP's GreenMetric score was 408 out of a possible 2100 in the Energy and Climate Change section in 2016. In the following year, UTP's energy score increased to 698 (UI GreenMetric, 2017). Even though the score was improved it remained only about 33% of the total points that could be earned in the section. The Energy and Climate Change section has the greatest weighting therefore increasing the points earned would have the largest impact on the score as a whole. After analyzing the documentation from last year along with the score criteria, our team has decided to focus on the Energy and Climate Change section because it is not only the section with the largest weight but also the section with the lowest score.

## AIR QUALITY

The current air quality monitoring system on the UTP campus is not functional, as last year's project team has also mentioned along with their recommendations. That is why Dra. Maytee Zambrano and Dra. Guadalupe Gonzalez, the UTP authorities in the Electrical Engineering Department, have asked for a possible replacement. Using the recommendations of last year's IQP team, we decided to test the feasibility of an Arduino module placed inside the casing used for the Libelium modules. Figure 4 shows a module of Libelium Waspote - Plug & Sense.



FIGURE 4: "LIBELIUM WASPMOTE - PLUG & SENSE!"

The main problems with Libelium modules are that they are not user-friendly, prone to failure and overpriced. However, the Libelium casing provides a durable waterproof environment for the system and this is essential to build a module that can endure the Panamanian weather for extended periods. Our team decided to test the feasibility of the MQ sensor series. The following sensors were used: MQ-4 was used to detect methane ( $\text{CH}_4$ ); MQ-7 for CO; MQ-131 for  $\text{O}_3$  and MQ-135 for sulfides and hazardous gases in general. In terms of detecting  $\text{CO}_2$ , there were multiple options available. However, few were suited to high precision, quantitative analysis (0 – 1000 ppm). After further research, we decided to use SKU:SEN0219 by DFRobot. This sensor uses infrared absorption gas detection and is suited for this type of measurement of carbon dioxide. For detecting particulate matter, we selected the most common sensor; the GP2Y1014AU by Sharp, which uses infrared absorption to detect dust at low power. Since neither UTP team from last year nor students at UTP were able to get readings from the modules, our team decided to remove the boards and replace them with Arduino sensor systems.

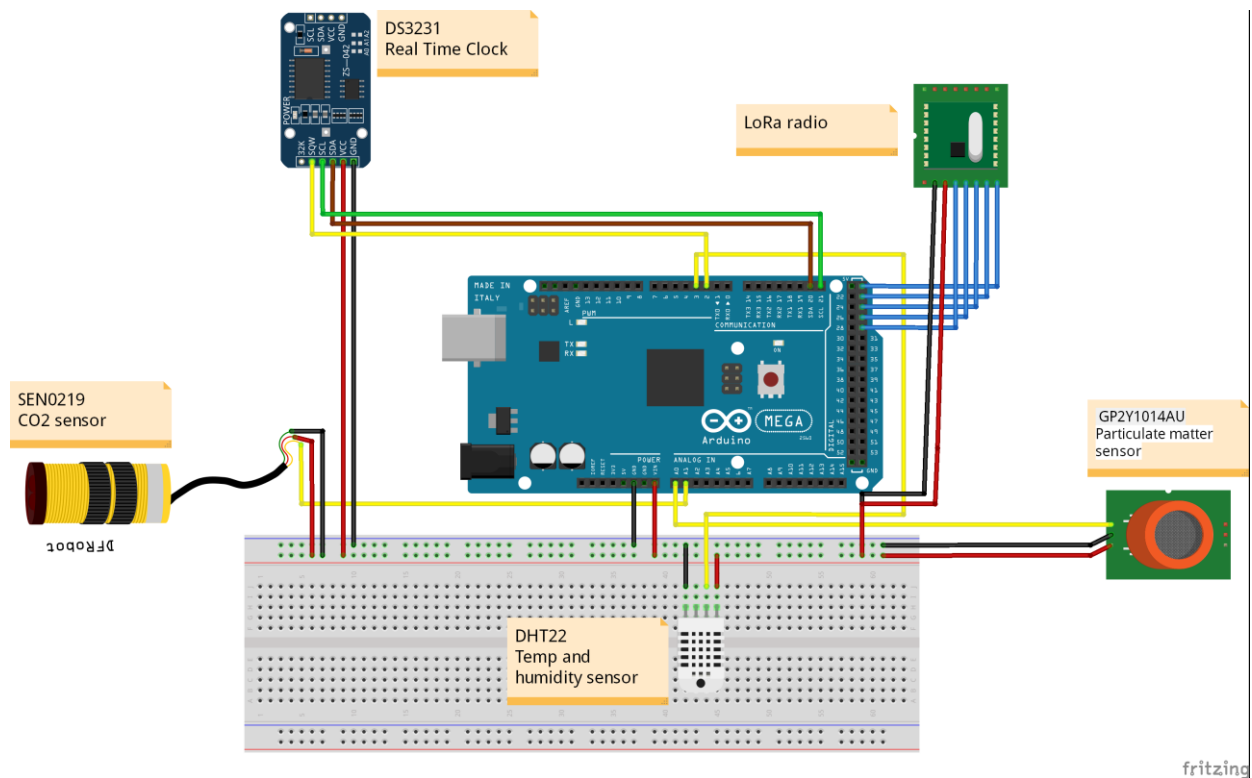

FIGURE 5: A ROUGH CIRCUIT DIAGRAM OF THE REPLACEMENT ARDUINO SYSTEM WITH THE SENSORS

The sensor node uses an Arduino Mega 2560 microcontroller to obtain readings from multiple air quality sensors. The circuit diagram of the sensor node with all connected components is shown in Figure 5. The sensors are read every hour with the help of hourly interrupts generated by a DS3231 real-time clock module. After taking the readings, the microcontroller transmits the data through LoRa radio and returns to low-power mode for an hour until the next interrupt is generated, and the process repeats. The data from the sensor node are received by a LoRa radio connected to an ESP32 microcontroller. The ESP32 has Wi-Fi capability and therefore serves as an internet gateway so that the data can be uploaded to a cloud database. For this purpose, we utilized the API from a free third-party service known as PushingBox to post the sensor readings to a spreadsheet hosted on Google Drive. A graphic representation of this system can be seen in Figure 6.

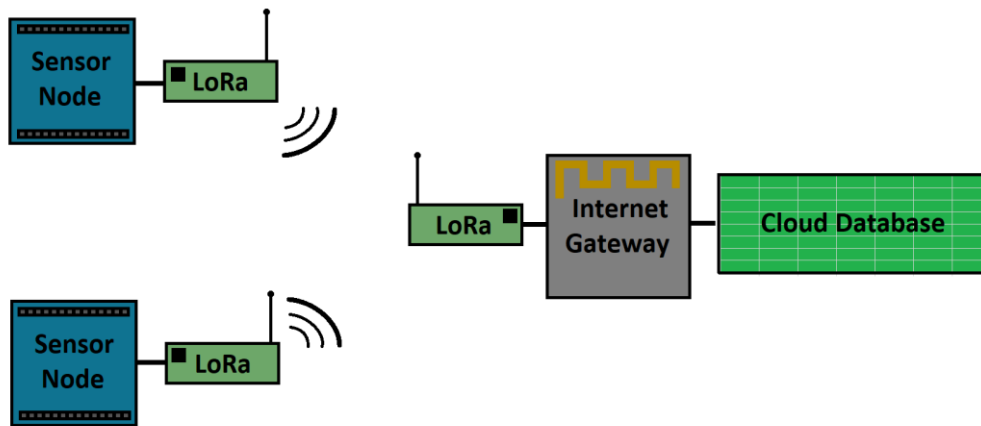

FIGURE 6: ILLUSTRATED BLOCK DIAGRAM OF SENSOR NETWORK

## ENERGY

For the energy part of Energy and Climate Change section, we researched energy conservation practices on campus because there was an existing monitoring method for energy unlike air quality. In order to assess energy conservation practices, there were two main types of data to be collected: from the students and from the staff. Our team decided to conduct a survey of energy conservation and sustainability practices in general to roughly gauge the environmental awareness of the students. As a developing nation, Panama is in a much different position when compared to the United States. Sustainability practices are common place in developed country are usually not adopted in developing nations due to different priorities in the economic models. A practice that has been adopted by the student body in American colleges might not be as widespread in Panama. Due to this, our team needed to assess the general awareness level on sustainability for the scope of the project.

In addition to the student survey, we prepared another set of questions about the inventory for the staff. According to the Energy Star guidelines, the devices with highest energy consumption are HVAC systems, lighting, refrigerating, and computers so our questions were mostly related to the energy consumption of these systems at UTP. To this end, we were encouraged to contact Italo Petrocelli, Director of Energy Savings at UTP.



## FINDINGS

As we approached the end of our project we had assembled a prototype air quality sensor node, gathered survey responses from students along with information on UTP's past and current sustainability improvement projects. In the end the sensor node was functioning as intended and was returning reasonable sample data barring technical difficulties with the communication hardware. The survey responses revealed that students in Building 1 used up little energy on their own. The largest areas for improvement based off the survey were the education and awareness sections.

### AIR QUALITY

We replaced the outdated Libelium Plug & Sense modules with our sensor node. This sensor node includes an Arduino microcontroller connected to a protoboard, CO<sub>2</sub> sensor (SKU:SEN0219), particulate matter sensor, temperature and humidity sensor, real-time clock module, and a long range distance module (LoRa). In their current state, the modules are able to receive readings of temperature, humidity, particulate matter, CO<sub>2</sub>, and then transmit that data to an online spreadsheet.

Our team tested the validity of the readings received from the sensors before putting the circuit inside the casing and calibrated them when necessary. During the calibration process, our group discovered that some of the sensors that were initially going to be incorporated were not sensitive enough to detect extremely slight amounts of certain gasses. These gases include carbon monoxide (CO) or methane (CH<sub>4</sub>). Sensors sensitive enough to detect these gasses are available on the market but would take several weeks of lead time to obtain. The remaining sensors were assembled and coded to give hourly readings. For testing purposes, the node was coded to provide readings every minute while connected printing the readings to a computer.

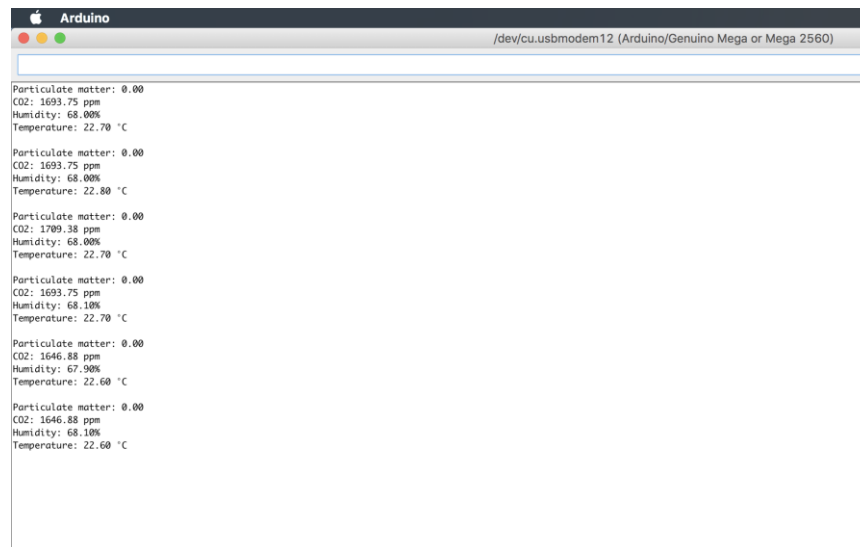

```

Arduino
/dev/cu.usbmodem12 (Arduino/Genuino Mega or Mega 2560)

Particulate matter: 0.00
CO2: 1693.75 ppm
Humidity: 68.00%
Temperature: 22.70 °C

Particulate matter: 0.00
CO2: 1693.75 ppm
Humidity: 68.00%
Temperature: 22.80 °C

Particulate matter: 0.00
CO2: 1709.38 ppm
Humidity: 68.00%
Temperature: 22.70 °C

Particulate matter: 0.00
CO2: 1693.75 ppm
Humidity: 68.10%
Temperature: 22.70 °C

Particulate matter: 0.00
CO2: 1646.88 ppm
Humidity: 67.90%
Temperature: 22.60 °C

Particulate matter: 0.00
CO2: 1646.88 ppm
Humidity: 68.10%
Temperature: 22.60 °C

```

**FIGURE 7: SAMPLE ARDUINO SENSOR DATA**

As it can be seen in the screenshot, the sensor node detected the necessary air properties and submitted the data. Figure 7 was obtained during the testing period of the sensor node while the node was connected to a computer. In the final design, the node was instead connected to an internet gateway module so that the data could be stored online. Figure 8 shows a sample set of data submitted by the ESP32 internet gateway module and stored in a Google spreadsheet:

44	10/3/2018	23.1	66.9	0	461.94
45	10/3/2018	23.1	68.5	0	543.09
46	10/3/2018	23.2	66.7	0	446.62
47	10/3/2018	23.2	66.5	0	434.38
48	10/3/2018	23.2	66.7	0	451.22
49	10/3/2018	28.9	73	0	463.47
50	10/3/2018	28.8	75.4	0	481.84

**FIGURE 8: SAMPLE SECTION OF DATA SPREADSHEET. COLUMNS (LEFT TO RIGHT): TIMESTAMP, TEMPERATURE IN DEGREES CELSIUS, HUMIDITY PERCENT, PARTICULATE MATTER, CO<sub>2</sub> IN PPM**

The spreadsheet consists of five columns. The internet module submits four types of readings in the order of temperature, humidity, particulate matter, carbon dioxide with a timestamp attached to each hourly reading at the leftmost column.

## SURVEY RESULTS

A student survey was undertaken to determine if common practices by the students could be wasting energy for the university. 350 surveys were given in Building 1 among various years and majors. These majors include Civil, Electrical, Mechanical, and Industrial Engineering. The survey inquired about the student's personal energy usage on campus as well as their awareness and interest in sustainability events on campus. The results were not a representation of the actual distribution of majors within Building 1.

## STUDENT SUSTAINABILITY PRACTICES

Six questions were asked to determine the level of sustainability practices used by the students at UTP. The first two questions concerned computer usage. The survey revealed that students used UTP's desktops and personal laptops for short periods of time.

- 64.3% of students reported that they use lab desktops for less than an hour
- 68.7% of students reported that they charged their laptop on campus for less than hour
- >5% of students reported using desktops or charging laptops for more than three hours
- 87% of students reported that they turn off computers, monitors, and other lab equipment after they finish using it

Students were also asked about their familiarity with Energy Star certified devices.

- 25.8% of students said they knew of Energy Star
- 15.1% said they purchase those products.

When asked about turning off lights in classrooms and labs, 45.3% of students said they turned off lights if they knew people would not be there for a long period of time (Figure 9). This is because classes and lab spaces are used throughout the day until nighttime, students do not see it as a priority as people utilize the rooms most of the time.

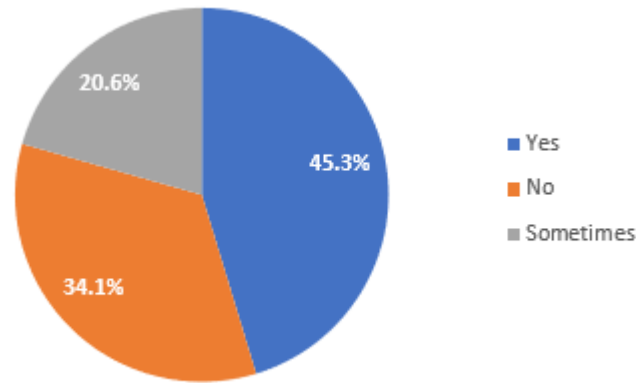

**FIGURE 9: PERCENTAGE OF STUDENTS WHO TURN OFF THE LIGHTS**

Students were also asked about their usual mode of transportation, which relates to the carbon footprint of UTP. The survey responses show that around 56.3% of students use public transportation, as shown in Figure 10. This is better for UTP's carbon footprint as public transportation cuts down on vehicle carbon dioxide emissions. Due to public transportation being extremely cheap at around \$0.35 for each trip number, the percentage is not liable to change drastically with the new parking lots being built.

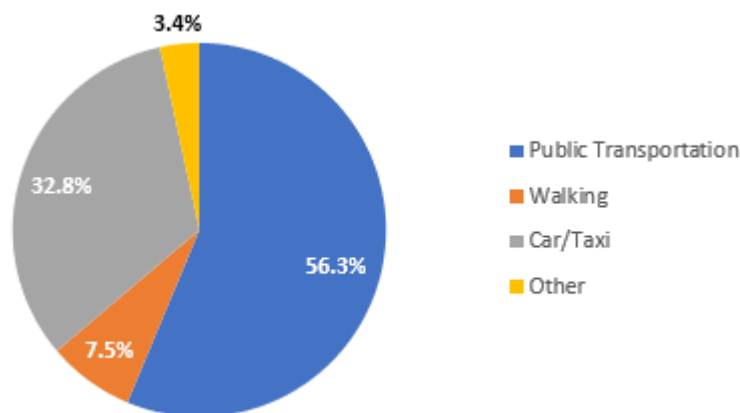
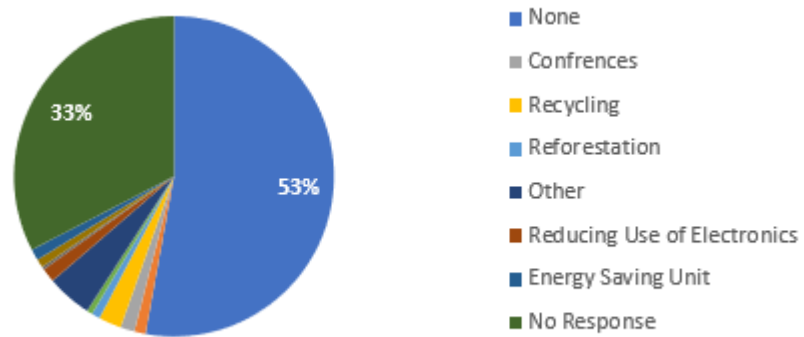

**FIGURE 10: STUDENT METHODS OF TRANSPORTATION**

#### STUDENT SUSTAINABILITY AWARENESS

For this part of the survey we collected data on how UTP is engaging the students in sustainability through events and how familiar students are with sustainability on an individual level. Examples of sustainability events include: lectures, project presentations, waste audits, fairs, and hands-on projects. 53% or more of students did not know of any sustainability events held by UTP (Figure 11). And 90% of students said they did not participate in any

such events. There is interest for sustainability activities because 64% of students responded that they would take a class focused on sustainability if one was offered at UTP.



**FIGURE 11: STUDENT FAMILIARITY OF UTP SUSTAINABILITY EVENTS**

## CONCLUSION AND RECOMMENDATIONS

The Electrical Engineering Department at UTP aimed to create a sustainable campus by implementing policies based off their campus setting and conditions. Previously an air quality monitoring system using Libelium Waspmote - Plug & Sense Modules was implemented, albeit not successfully. The purpose of these sensors was to measure the gas concentrations on campus to analyze and act on the data that they receive. This would enable UTP to view the amount of greenhouse gases on campus. For a sensor node to provide a comprehensive set of data on greenhouse gases, it needs to be able to detect most impactful greenhouse gases such as carbon dioxide, ozone, and methane. However, the sensor node that we produced was only able to sense carbon dioxide and particulate matter. The ozone and methane sensors that we attempted to use were from the MQ series of sensors. These sensors were not sensitive enough to detect the slight amounts of gasses found in open air. The CO<sub>2</sub> sensor the we chose had a high price tag, but the node still consists of inexpensive parts compared to the cost of the Libelium modules. In addition, the node consists of parts that have extensive documentation online, compared to the Libelium modules which have both proprietary software and hardware. Arduino is an open-source platform. The open source nature of Arduino and the sensors used allows flexibility for future users to repair, replace, and improve the sensor nodes. Further research on better performing sensors can be made to retrofit the current sensor node in the future as well.

Of all the greenhouse gases, carbon dioxide has the greatest impact on the environment. Carbon dioxide's impact on the climate change is only around 20% while in comparison, the impact of water vapor is around 70%. (Air Test Technologies) Although our team was not able to find feasible ozone and methane sensors, the sensor node can still detect the greenhouse gas that is not only the most impactful, it is also the gas for which humans are most responsible.

GreenMetric includes two criteria in Energy and Climate Change section that requires a greenhouse reduction program and a carbon footprint calculation program. These criteria address about 500 out of 2100 points awarded for Energy and Climate Change section. These programs require universities to submit numbers to be evaluated by the grading committee. Measuring carbon emissions is essential for both programs. UTP needed to accumulate the data of CO<sub>2</sub> emissions over past 12 months and calculate the ratio of carbon emissions to the population on campus as well as calculate greenhouse emissions. In order to make this calculation, sensing CO<sub>2</sub> is necessary and will result in UTP's eligibility to receive points out of 300 since their carbon footprint will be evaluated and awarded points. (UI GreenMetric, 2017)

Our efforts have not only increased UTP's GreenMetric score, but also paved the way for further improvements in the future. Our air quality monitoring system was designed to be improved in the future by adding more sensors and improving upon the current network. We hope that this, along with our recommendations based on the survey responses we collected, will help UTP strive to constantly be improving sustainable practices among its many campuses.

## GREENMETRIC PROJECTION

With the data gathered from Italo Petrocelli, the survey, and our feasibility test on air quality monitoring, we calculated that UTP is subject to increase its GreenMetric score by 200 points with the current initiatives taken by UTP officials and sustainability managers, and recommendations provided by our team. UTP currently has a score of about 700 points out of 2100 and with the increase, UTP will get closer to the top green campuses according to GreenMetric (Wageningen University, 2017), which scored about 1300 points in the Energy and Climate Change section in 2017 (UI GreenMetric, 2017). To provide this projection, we went through 8 criteria presented under Energy and Climate Change. Each of the criteria asks the stage of sustainability projects and what part of the process the university is at. However, a few criteria in this subsection ask for numeric data on energy consumption and gas emissions that UTP does not have. This type of data is sent to a GreenMetric grading committee and the evaluation of the committee determines the final score awarded. We decided to exclude these types of criteria and scores responding to them while making our projection.

## AIR QUALITY MONITORING RECOMMENDATIONS

Air quality monitoring at all UTP campuses will be more achievable with the new Arduino modules. The total cost of the modules excluding the reused housing of the Libelium sensors, soldering, and silicon was around \$170 as shown in Figure 12. The carbon monoxide, sulfides, and ozone sensors each cost \$10 or less, but were not utilized. More accurate gas sensors of these types will cost around \$20 each but have large lead times or higher shipping costs.

	Board	CO <sub>2</sub> sensor	PM2.5 sensor	Temperature	Clock	LoRa	Proto-Shield	Solar Powered Battery
Cost	20.00	58.00	14.99	9.99	7.89	17.98	11.75	29.99
							Total	170.59

**FIGURE 12: TOTAL COST OF AIR QUALITY MONITORING MODULE**

Nonetheless, these Arduino modules still cost thousands of dollars less than Libelium Plug & Sense modules even with extra sensors. Our recommendation is to produce more of Arduino-based modules and begin using them in all UTP campuses. More sensors per campus would also make for a wider coverage area. Data collected from

different locations could also provide an air quality gradient and identify locations of pollution hotspots. Initially we planned to provide a set of guidelines to UTP assuming we had received enough readings for interpretation to initiate the initial implementation to reduce carbon emissions. However, this will be made viable by initiating an air quality monitor network. UTP will be able to interpret the data they will receive to adjust their air quality policies in the following years.

While we believe our system is a good solution for monitoring air quality, we learned much from the challenges we faced, and recommend a few changes to the current design to facilitate in their implementation. Firstly, the CO<sub>2</sub> sensor we ordered proved to be difficult to work with as it required intensive calibration to obtain accurate measurements, and there is little documentation on the product. We recommend finding a more reliable sensor for measuring CO<sub>2</sub> levels. Also, while the radio modules are rated for long distance communication, we faced reception problems while trying to receive data from inside the building. We recommend that the radios be in direct line of sight to utilize their full range. A detailed description of the system that serves as instructions for further implementation can be found in Appendix E.

## ENERGY RECOMMENDATIONS

The most important discovery we made when determining the gaps in UTP's sustainability practices concerning energy use is that the Energy Savings Department had already finished or planned to make the changes to infrastructure that would make the largest impact. The biggest issue that the department has is very little communication with departments at the university. This creates a situation where departments might be working on similar projects, and not know that the other project is already underway. This holds the community back in constructing more specific solutions and causes project redundancy. In our meetings with the faculty from the Electrical Engineering Department, we were encouraged to get in contact with particular people that contribute to sustainability on campus. We presented them questions regarding projects and gathered information on how there were projects about LED replacements, air conditioning systems, and renewable energy.

Regarding what is being done at UTP, there can be more done to save energy in Building 1. In addition to the modifications they have already undertaken with the HVAC system, light controls should be installed in every classroom. These control systems use motion sensing and natural light sensing to turn off or dim the lights in the classroom automatically. This system can run in multiple configurations. If staff and students are concerned about the motion sensor turning off the lights during class, then the system can be set to light dimming only. To further



decrease energy usage by interior lighting, many of the fluorescent lights could be replaced with more efficient LEDs. LED lighting is not only more efficient, but also requires less maintenance than fluorescent tubes.

Overall insulation of Building 1 is poor. Half of the interior of the building is not airconditioned, with only glass double doors separating this section from the air-conditioned section. These doors maintain heavy foot traffic as well and are opened and closed many times a day. Furthermore, many windows are often left open the air-conditioned section of the building. While redesigning the building layout to be more mindful of efficient air conditioning methods would be a large undertaking, encouraging simple practices such as making sure windows stay shut would make a big difference in saving energy while keeping the building cool.

## SUSTAINABILITY AWARENESS RECOMMENDATIONS

The survey results reveal that the student body of Building 1 do not have much knowledge on sustainability practices. UTP administration and faculty are not also active in terms of promoting sustainability awareness. Superficial events or volunteering events realistically will not appeal to UTP students. The students are busy with course work and do not have the same college culture concerning environmental awareness that is prevalent at WPI and other college campuses in the United States. Events such as Waste Audits work well at colleges with residential halls where students are directly responsible for the waste they produce on campus. However, UTP does not have residential halls so this type of event would be unlikely to garner interest. Our recommendation for UTP is to host well-organized events with the theme of sustainability.

A solution to concerns about students not participating in sustainability events because it could interfere with their course work would be to integrate environmental awareness into the curriculum. In our surveys, we found out that 64% of students said they would be interested in taking classes based on sustainability. If UTP offers sustainability classes, the credit earned would present a strong incentive for students to learn about environmental awareness. Offering these types of classes would also bolster UTP's GreenMetric score in the Education section.

## FUTURE PROJECT RECOMMENDATIONS

As a result of this project, one of the main recommendations our team determined for future reference is to establish contact with the sponsor as soon as possible and decide on the objectives well in advance. The lead time on ordering parts could take anywhere from 3 weeks to 1 month due to the shipping conditions. For that reason, trying to order these sensors while in Panama was impractical. A future team could determine the sensors ahead of time and receive the appropriate sensors before arriving to the project site. This is strongly advised because of the

difficulty of finding time for ordering sensitive sensors available for retail, having products shipped in a reasonable amount of time, and sparing the remaining time on planning and assembling. Especially for assembly, there needs to be an extended time spent on spotting potential issues, bugs, and glitches as well as working on current ones. For this year, our team agreed that if circumstances allowed WPI and UTP team to establish the scope of the project earlier in the summer, parts could have been prepared before working on UTP campus in order to spend more time on the implementation, which would have made the deliverable more diversified and reliable.

The greatest problem we faced after the time limitation was availability of the sensors to set up an air quality monitoring system. The sensors that were used for this project are replaceable with more reliable parts that can be considered industry standard. The only sensor that was available and viable for detecting slight amounts was the CO<sub>2</sub> sensor called SKU:SEN0219 and our group had issues calibrating it. Although this sensor was troublesome despite a price tag of \$50, and there are sensors that are more user-friendly with a slightly higher price tag, this node would still make an air quality monitoring option significantly cheaper than buying Libelium products. Another issue when creating the node was the lack of devices such as soldering equipment. Yet, this was an issue that we overcame with the help of a fifth year UTP student assigned to work with us as well as the staff's assistance.

Having worked at UTP for about 2 months, our group experienced another issue that we believe is essential to the improvement of sustainability practices and awareness on campus. The campus consists of multiple buildings with a few departments occupying a floor per department each building. This allows for each floor to cooperate way more efficiently but reduces the communication between departments and different offices on campus. Most of the data concerning energy consumption and projects that UTP has in initial planning stage were not available for our sponsors at Electrical Engineering Department and when we found out, we had to present the data to them. There is a lack of intercommunication and certain information can only be found by asking the right people on campus. We believe this is not only an aspect to pay attention to but also an area that can be worked on within the scope of this project.

## BIBLIOGRAPHY

- Air Test Technologies. (n.d.). *A White Paper: CO2 Ventilation Control And Measurement Of Outside Air*. Retrieved from [www.AirTestTechnologies.com](http://www.AirTestTechnologies.com):  
<https://www.airtesttechnologies.com/support/datasheet/CO2MeasurementAndOutsideAir.pdf>
- Burger, A. (2014, 8 5). *Panama City's Sustainable and Resilient Infrastructure Development*. Retrieved from Government Technology: <http://www.govtech.com/local/GT-Panama-Citys-Sustainable-and-Resilient-Infrastructure-Development.html>
- Department of international affairs. (2016). *Study Abroad in Panama*. Retrieved from Universidad Tecnológica de Panamá: [http://www.utp.ac.pa/documentos/2016/pdf/Come\\_for\\_an\\_Exchange\\_Program\\_at\\_UTP.pdf](http://www.utp.ac.pa/documentos/2016/pdf/Come_for_an_Exchange_Program_at_UTP.pdf)
- Dworak, M., MacLeod, T., Mears, N., & Wernsing, G. (2017, October 11). *Implementing Environmental Indexing and Monitoring at the Technological University of Panama (Undergraduate Interactive Qualifying Project No. E-Project-101117-122452)*. Retrieved from <https://web.wpi.edu/Pubs/E-project/Available/E-project-101117-122452/>
- export.gov. (2016, 4 17). *Panama - Electrical Power*. Retrieved from [export.gov](http://export.gov):  
<https://www.export.gov/article?id=Panama-Electrical-Power>
- Gustavo Anguizola, R. L. (2018, 2 7). *Panama*. Retrieved from Encyclopedia Britannica:  
<https://www.britannica.com/place/Panama>
- Lambert, T. (2017). *A BRIEF HISTORY OF PANAMA*. Retrieved from Local Histories:  
<http://www.localhistories.org/panama.html>
- Matthews, R. (2017, 9 20). *Complete World University Rankings of Green Schools*. Retrieved from The Green Market Oracle: <http://www.thegreenmarketoracle.com/2017/09/complete-world-university-rankings-of.html>
- Mellino, C. (2014, 12 17). *Top 10 Universities Taking the Lead on Sustainability*. Retrieved from EcoWatch:  
<https://www.ecowatch.com/top-10-universities-taking-the-lead-on-sustainability-1881990599.html>
- O'Hara, C., Hobson-Dupont, M., Hurgin, M., & Thierry, V. (2007, May 5). *Monitoring Electricity Consumption on the WPI Campus (Undergraduate Interactive Qualifying Project No. E-project-060107-130245)*. Retrieved from <https://web.wpi.edu/Pubs/E-project/Available/E-project-060107-130245/unrestricted/iqpfinaldraft.pdf>
- POLS Attorneys. (2015, 10 16). *Panama Investing Big in Clean energy and Sustainable Development*. Retrieved from POLS Attorneys: [http://www.panama-offshore-services.com/blog/panama\\_investing\\_in\\_clean\\_energy\\_and\\_sustainable\\_development.htm](http://www.panama-offshore-services.com/blog/panama_investing_in_clean_energy_and_sustainable_development.htm)
- Prescott College. (2017, April 30). *Campus Energy Dashboard*. Retrieved from Pulse Energy:  
<https://us.pulseenergy.com/PrescottCollege/dashboard/>
- Stankovitch, A. B. (2017, 6). *Why Did You Come to Kalu Yala? 32 Students Share Their Aspirations*. Retrieved from Kalu Yala: <https://blog.kaluyala.com/why-did-you-come-to-kalu-yala/>
- UI GreenMetric. (2017). *Overall Rankings 2017*. Retrieved from UI GreenMetric: <http://greenmetric.ui.ac.id/overall-ranking-2017/>
- United States Central Intelligence Agency. (2009). *Central America and Caribbean: Panama*. Retrieved from The World Factbook: [https://www.cia.gov/library/publications/the-world-factbook/geos/print\\_pm.html](https://www.cia.gov/library/publications/the-world-factbook/geos/print_pm.html)
- United States Environment Protection Agency. (2016, October 18). *Learn About Sustainability*. Retrieved from EPA:  
<https://www.epa.gov/sustainability/learn-about-sustainability>

Wageningen University. (2017). *Sustainability*. Retrieved from Wageningen University & Research:  
<https://www.wur.nl/en/About-Wageningen/Sustainability.htm>

WBWire. (2017, 12 15). *University of Nottingham named as second greenest campus in the world*. Retrieved from West Bridgford Wire: <https://westbridgfordwire.com/university-nottingham-named-second-greenest-campus-world/>

WPI. (n.d.). *WPI Sustainability Plan*. Retrieved from WPI:  
[https://web.wpi.edu/Images/CMS/Facilities/WPI\\_Sustainability\\_Plan.pdf](https://web.wpi.edu/Images/CMS/Facilities/WPI_Sustainability_Plan.pdf)

## APPENDICES

### APPENDIX A: BREAKDOWN OF THE GREENMETRIC 2016 RANKING SYSTEM (UI GREENMETRIC, 2017)

The table below is the breakdown of the subsections and the weight corresponding to each criterion in the subsections. We focused our scope on Energy and Climate Change (EC) and eight criteria regarding EC.

No	Categories and Indicators	Points	Weighting
<b>Setting and Infrastructure (SI)</b>			<b>15%</b>
SI 1	The ratio of open space area towards total area	300	
SI 2	The ratio of open space area towards campus population	300	
SI 3	Area on campus covered in forest	200	
SI 4	Area on campus covered in planted vegetation	200	
SI 5	Area on campus for water absorbance	300	
SI 6	University budget for sustainable effort	200	
Total	1500		
<b>Energy and Climate Change (EC)</b>			<b>21%</b>
EC 1	Energy efficient appliances usage	200	
EC 2	Smart building implementation	300	
EC 3	Renewable energy produce on campus	300	
EC 4	The ratio of total electricity usage towards campus population	300	
EC 5	The ratio of renewable energy produce towards energy usage	200	
EC 6	Element of green building implementation	300	
EC 7	Greenhouse gas emission reduction program	200	
EC 8	The ratio of total carbon footprint towards campus population	300	
Total	2100		
<b>Waste (WS)</b>			<b>18%</b>
WS 1	Program to reduce the use of paper and plastic in campus	300	
WS 2	Recycling program for university waste	300	
WS 3	Toxic waste handled	300	
WS 4	Organic waste treatment	300	
WS 5	Inorganic waste treatment	300	
WS 6	Sewerage disposal	300	
Total	1800		
<b>Water (WR)</b>			<b>10%</b>
WR 1	Water conservation program	300	
WR 2	Water recycling program	300	
WR 3	The use of water efficient appliances	200	
WR 4	Piped water consumed	200	
Total	1000		
<b>Transportation (TR)</b>			<b>18%</b>
TR 1	The ratio of vehicles (cars and motorcycles) towards campus population	200	
TR 2	The ratio of shuttle services towards campus population	200	

| TR 3 The ratio of bicycles towards campus population

---

200

No	Categories and Indicators	Points	Weighting
TR 4	Parking area type		200
TR 5	Transportation initiatives to decrease private vehicles on campus		200
TR 6	Parking area reduction for private vehicles over the last 3 years (from 2014 to 2016)		200
TR 7	Shuttle services		300
TR 8	Bicycle and pedestrian policy on campus		300
Total	1800		
<b>Education (ED)</b>			<b>18%</b>
ED 1	The ratio of sustainability courses towards total courses/modules		300
ED 2	The ratio of sustainability research funding towards total research funding		300
ED 3	Sustainability publications		300
ED 4	Sustainability events		300
ED 5	Sustainability student organizations		300
ED 6	Sustainability websites		300
Total	1800		
<b>TOTAL</b>			<b>10</b>

## APPENDIX B: CODE SAMPLE FOR SENSOR NODE

This is the code used for the Arduino Mega microcontroller that controls the sensor node.

```
1. // Libraries Used
2. /*****/
3. #include <DHT.h>
4. #include <SPI.h>
5. #include <LoRa.h>
6. #include <Wire.h>
7. #include <RTCLibExtended.h>
8. #include <LowPower.h>
9. #include <Time.h>
10.
11. // PINS
12. /*****/
13. #define DHTPIN 7
14. #define ss 5
15. #define rst 8
16. #define dio0 3
17. #define DHTTYPE DHT22 // DHT 22 (AM2302)
18. #define wakePin 2 //use interrupt 0 (pin 2) and run function wakeUp when pin 2 gets
    LOW
19. #define ledPin 13 //use arduino on-board led for indicating sleep or wakeup status
20.
21. RTC_DS3231 RTC; //we are using the DS3231 RTC
22.
23. byte AlarmFlag = 0;
24. byte ledStatus = 1;
25. float awakeCount = 0;
26.
27.
28. int dustPin = A4;
29. int CO2Pin = A1;
30.
31. // Initial Values and Constants
32. /*****/
33. float dustVal=0;
34. float pmVal=0;
35. String pmPrint = "";
36. String co2Print = "";
37. float concentration=0;
38. float h=0;
39. float t=0;
40.
41. float R0 = 11.820;
42. int gas_sensor = A10;
43. float m = -0.318; //Slope
44. float b = 1.133; //Y-Intercept
45.
46. void wakeUp() // here the interrupt is handled after wakeup
47. {
48. }
49.
50. DHT dht(DHTPIN, DHTTYPE);
51.
52. void setup() {
53.   Serial.begin(9600);
54.   dht.begin();
55.   analogReference(DEFAULT);
```



```
56. pinMode(dustPin, INPUT);
57. LoRa.setPins(ss, rst, dio0);
58. while (!LoRa.begin(433E6)) {
59.     Serial.println(".");
60.     delay(500);
61. }
62. LoRa.setSyncWord(0xF3);
63. Serial.println("LoRa Initializing OK!");
64.
65. //Set pin D2 as INPUT for accepting the interrupt signal from DS3231
66. pinMode(wakePin, INPUT);
67.
68. //switch-on the on-
  board led for 1 second for indicating that the sketch is ok and running
69. pinMode(ledPin, OUTPUT);
70. digitalWrite(ledPin, HIGH);
71. delay(1000);
72.
73. //Initialize communication with the clock
74. Wire.begin();
75. RTC.begin();
76. RTC.adjust(DateTime(F(__DATE__), F(__TIME__))); //set RTC date and time to COMPILE
  time
77.
78. //clear any pending alarms
79. RTC.armAlarm(1, false);
80. RTC.clearAlarm(1);
81. RTC.alarmInterrupt(1, false);
82. RTC.armAlarm(2, false);
83. RTC.clearAlarm(2);
84. RTC.alarmInterrupt(2, false);
85.
86. //Set SQW pin to OFF (in my case it was set by default to 1Hz)
87. //The output of the DS3231 INT pin is connected to this pin
88. //It must be connected to arduino D2 pin for wake-up
89. RTC.writeSqwPinMode(DS3231_OFF);
90.
91. RTC.setAlarm(ALM1_MATCH_MINUTES, 0, 0, 0); //set your wake-up time here
92. RTC.alarmInterrupt(1, true);
93. }
94.
95. //5V
96. //3000 + = Very Bad
97. //1050-3000 = Bad
98. //300-1050 = Ordinary
99. //150-300 = Good
100. //75-150 = Very Good
101. //0-75 = Tiptop
102. void readPM(void)
103. {
104.     dustVal=analogRead(dustPin);
105.     if (dustVal>36.455)
106.     {
107.         pmVal = (float(dustVal/1024)-0.0356)*120000*0.035;
108.     }
109.     Serial.print("\n");
110.     Serial.print("Particulate matter:");
111.     Serial.println(pmVal);
112. }
113.
114. //5V
```

```
115.     //normal 350-400ppm
116.     //max 1000ppm
117.     //dangerous over 2000ppm
118.     void readCO2(void)
119.     {
120.         for (int i = 0; i <= 90; i++) {
121.             int useless = analogRead(CO2Pin);
122.             delay(1000);
123.         }
124.         delay(300);
125.         int sensorValue1 = analogRead(CO2Pin);
126.         delay(300);
127.         int sensorValue2 = analogRead(CO2Pin);
128.         delay(300);
129.         int sensorValue3 = analogRead(CO2Pin);
130.         delay(300);
131.         int sensorValue4 = analogRead(CO2Pin);
132.         delay(300);
133.         int sensorValue5 = analogRead(CO2Pin);
134.         delay(300);
135.         int sensorValue6 = analogRead(CO2Pin);
136.         delay(300);
137.         int sensorValue7 = analogRead(CO2Pin);
138.         delay(300);
139.         int sensorValue8 = analogRead(CO2Pin);
140.         delay(300);
141.         int sensorValue9 = analogRead(CO2Pin);
142.         delay(300);
143.         int sensorValue10 = analogRead(CO2Pin);
144.
145.         float voltage = (sensorValue1 + sensorValue2 + sensorValue3 + sensorValue4 + s
ensorValue5 + sensorValue6 + sensorValue7 + sensorValue8 + sensorValue9 + sensorValue10
) / 10.0;
146.
147.         // The analog signal is converted to a voltage
148.         float voltage_difference = (voltage * 0.0049) - 0.4;
149.         concentration = voltage_difference * (5000 / 1.6);
150.         //Print CO2 concentration
151.         Serial.print("CO2: ");
152.         Serial.print(concentration);
153.         Serial.println(" ppm");
154.     }
155.
156.     void readTempAndHum(void)
157.     {
158.         h = dht.readHumidity();
159.         t = dht.readTemperature();
160.
161.         if (isnan(h) || isnan(t)) {
162.             Serial.println("Failed to read from DHT sensor!");
163.             return;
164.         }
165.
166.         Serial.print("Humidity: ");
167.         Serial.print(h);
168.         Serial.print(" %");
169.         Serial.print("\n");
170.         Serial.print("Temperature: ");
171.         Serial.print(t);
172.         Serial.println("°C");
173.     }
```

```
174.
175.     void loop() {
176.         //On first loop we enter the sleep mode
177.         if (AlarmFlag == 0) {
178.             awakeCount = 0;
179.             attachInterrupt(0, wakeUp, LOW);           //use interrupt 0 (pin
n 2) and run function wakeUp when pin 2 gets LOW
180.             digitalWrite(ledPin, LOW);               //switch-
off the led for indicating that we enter the sleep mode
181.             ledStatus = 0;                           //set the led status
accordingly
182.             LowPower.powerDown(SLEEP_FOREVER, ADC_OFF, BOD_OFF); //arduino enters sleep
mode here
183.             detachInterrupt(0);                       //execution resumes from
here after wake-up
184.
185.
186.             //When exiting the sleep mode we clear the alarm
187.             RTC.armAlarm(1, false);
188.             RTC.clearAlarm(1);
189.             RTC.alarmInterrupt(1, false);
190.             RTC.armAlarm(2, false);
191.             RTC.clearAlarm(2);
192.             RTC.alarmInterrupt(2, false);
193.             AlarmFlag++;
194.         }
195.
196.         if (AlarmFlag != 0) {
197.             digitalWrite(ledPin, HIGH);
198.         }
199.
200.         readPM();
201.         delay(1000);
202.         readCO2();
203.         delay(1000);
204.         readTempAndHum();
205.         delay(1000);
206.
207.         // Modifies the package to be sent via LoRa modules
208.         if (pmVal >= 10.0) {
209.             pmPrint = (String) pmVal;
210.         } else {
211.             pmPrint = "0" + (String) pmVal;
212.         }
213.
214.         co2Print = (String) concentration;
215.         if (concentration >= 1000.0) {
216.             co2Print = "999.99";
217.         }
218.
219.         LoRa.beginPacket();
220.         LoRa.print((String) t + (String) h + pmPrint + co2Print);
221.         LoRa.endPacket();
222.
223.         delay(1000);
224.         RTC.setAlarm(ALM1_MATCH_MINUTES, 0, 0, 0); //set your wake-up time here
225.         RTC.alarmInterrupt(1, true);
226.         AlarmFlag--;
227.
228.     }
```

## APPENDIX C: CODE SAMPLE FOR ESP32

This is the code used for the NodeMCU-32s (ESP32) microcontroller that uploaded the sensor data to cloud storage via WIFI connection.

```
1. #include <SPI.h>
2. #include <WiFi.h>
3. #include <LoRa.h>
4.
5. #define ss 5
6. #define rst 14
7. #define dio0 2
8.
9. String LoRaData;
10. String LoRaData0;
11. String LoRaData1;
12. String LoRaData2;
13. String LoRaData3;
14. int packetSize;
15.
16. const char WEBSITE[] = "api.pushingbox.com"; //pushingbox API server
17. const String devid = "vD0483C613E0CD23"; //device ID from Pushingbox
18.
19. const char* MY_SSID = "GITTS-WiFi"; //wifi network ID
20. const char* MY_PWD = "signals2018"; //network password
21.
22. void setup()
23. {
24.   Serial.begin(115200);
25.
26.   //initialize LoRa
27.   LoRa.setPins(ss, rst, dio0);
28.   while (!LoRa.begin(433E6)) {
29.     Serial.println(".");
30.     delay(500);
31.   }
32.   LoRa.setSyncWord(0xF3);
33.   Serial.println("LoRa Initializing OK!");
34.
35.   //connect to wifi
36.   Serial.print("Connecting to "+MY_SSID);
37.   WiFi.begin(MY_SSID, MY_PWD);
38.   Serial.println("going into wl connect");
39.
40.   while (WiFi.status() != WL_CONNECTED) //not connected,..waiting to connect
41.     {
42.       delay(1000);
43.       Serial.print(".");
44.     }
45.   Serial.println("wl connected");
46.   Serial.println("");
47.   Serial.println("Credentials accepted! Connected to wifi\n ");
48.   Serial.println("");
49.
50.   //postData();
51. }
52.
53. //function to add recieved data to the spreadsheet
```

```
54. void postData()
55. {
56.     WiFiClient client; //Instantiate WiFi object
57.
58.     //Start or API service using our WiFi Client through PushingBox
59.     if (client.connect(WEBSITE, 80))
60.     {
61.         client.print("GET /pushingbox?devid=" + devid
62.         + "&humidityData=" + LoRaData0
63.         + "&celData=" + LoRaData1
64.         + "&fehrData=" + LoRaData2
65.         + "&hicData=" + LoRaData3
66.         + "&hifData=" + "N/A"
67.         );
68.
69.         client.println(" HTTP/1.1");
70.         client.print("Host: ");
71.         client.println(WEBSITE);
72.         client.println("User-Agent: ESP8266/1.0");
73.         client.println("Connection: close");
74.         client.println();
75.     }
76. }
77.
78. void loop() {
79.     int packetSize = LoRa.parsePacket();
80.     if (packetSize) {
81.         // received a packet
82.         Serial.print("Received packet ");
83.
84.         // read packet
85.         while (LoRa.available()) {
86.             LoRaData = LoRa.readString();
87.             Serial.print(LoRaData);
88.         }
89.
90.         // print RSSI of packet
91.         Serial.print(" with RSSI ");
92.         Serial.println(LoRa.packetRssi());
93.
94.         LoRaData0 = LoRaData.substring(0,5);
95.         LoRaData1 = LoRaData.substring(5,10);
96.         LoRaData2 = LoRaData.substring(10,15);
97.         LoRaData3 = LoRaData.substring(15,21);
98.
99.         Serial.println(LoRaData0);
100.         Serial.println(LoRaData1);
101.         Serial.println(LoRaData2);
102.         Serial.println(LoRaData3);
103.
104.         postData();
105.         delay(5000);
106.
107.         ESP.restart();
108.     }
109. }
```

## APPENDIX D: SURVEY IN SPANISH



## Uso energético UTP

Qué año académico cursa usted?

- I
- II
- III
- IV
- V

Qué facultad pertenece?

- Facultad de Ingeniería Eléctrica
- Facultad de Ingeniería Civil
- Facultad de Ingeniería Mecánica
- Facultad de Ingeniería Industrial
- Other: \_\_\_\_\_ 

Cuál es el estimado de tiempo en el que usa computadoras de escritorio en un día en la universidad?

- Menos de 1 hora
- 1-3
- 3-6
- 6-12
- 12 horas o más



Alrededor de cuanto tiempo deja su laptop cargando en la universidad?

- Menos de 1 hora
- 1-3
- 3-6
- 6-12
- 12 horas o más

Usted apaga los computadoras y monitores una vez terminado su trabajo en el laboratorio?

- Sí
- No
- A veces

Usted apaga el equipo de laboratorio(fuentes, osciloscopio, etc) una vez finaliza su trabajo?

- Sí
- No
- A veces

Apaga usted las luces cuando sabe que no estará en el salón por un tiempo prolongado?

- Sí
- No
- A veces



Está familiarizado con la certificación Energy Star de dispositivos electrónicos.

- Sí
- No



Cuando compra dispositivos electrónicos se asegura que estén bajo la certificación ENERGY Star?

- Sí
- No

Qué tipo de proyectos o eventos de concientización y sostenibilidad conoce usted en la universidad?

Your answer \_\_\_\_\_





Participa en alguno de estos eventos?

- Si
- No
- A veces

Algún evento en especifico sobre sostenibilidad y concientización que le gustaría ver en la universidad?

Your answer \_\_\_\_\_

Estaría interesado en tomar clases enfocadas en sostenibilidad?

- Si
- No
- Tal vez

Cual es su medio de transporte a la universidad?

- Caminando
- Bicicleta
- Carro
- Uber/Taxi
- Transporte Publico
- Other: \_\_\_\_\_



Cuantos dias a la semana usa este metodo?

- 1
- 2
- 3
- 4
- 5
- 6
- 7

Cómo reduciría el uso energetico mientras está en el campus?

Your answer

**SUBMIT**

Never submit passwords through Google Forms.

This content is neither created nor endorsed by Google. Report Abuse - Terms of Service - Additional Terms

Google Forms



## APPENDIX E: SURVEY RESULTS (TRANSLATED TO ENGLISH)

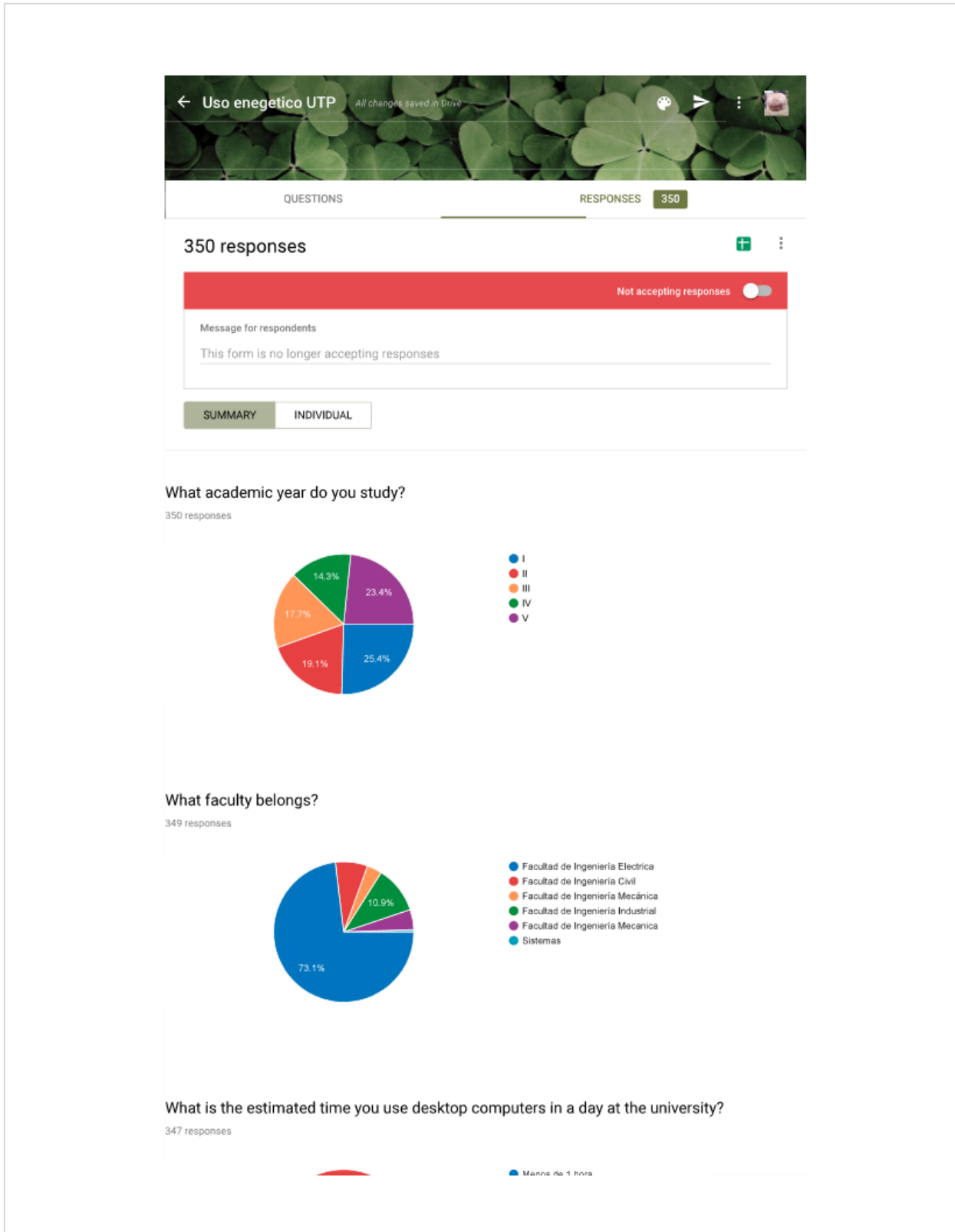

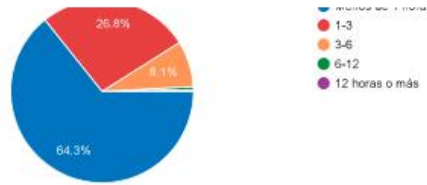

Around how much time does your laptop leave at the university?

342 responses

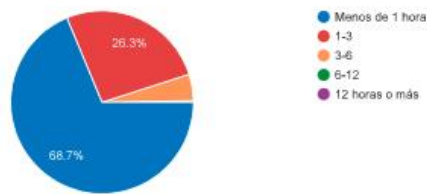

Do you turn off computers and monitors once you finish your work in the laboratory?

346 responses

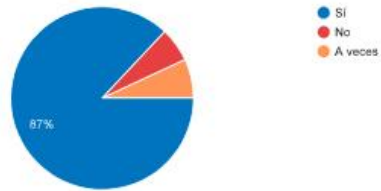

Do you turn off the laboratory equipment (sources, oscilloscope, etc.) once your work is finished?

348 responses





Do you turn off the lights when you know you will not be in the room for a long time?

349 responses

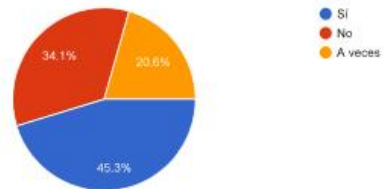

He is familiar with the Energy Star certification of electronic devices.

349 responses

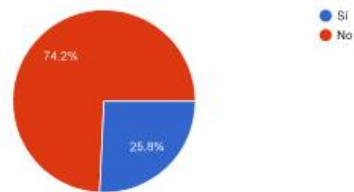

When you buy electronic devices does it ensure that they are under the ENERGY Star certification?

350 responses

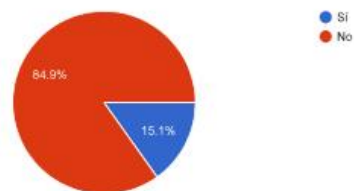

What kind of awareness and sustainability projects or events do you know at the university?

246 responses

None (68)	
none (45)	
no (18)	
None (13)	
None (7)	
I do not know (3)	
No (2)	
I do not know (2)	
IEEE (2)	
none (2)	
congresses (2)	
I do not know (2)	
Recycling (2)	
In college, none	
ningunk	
I dont know	
I do not know	
for now none	
I could not tell	
the reforestation	
any.	
IEEE	
In the classrooms there are signs and posters to turn off the lights when leaving the room, and in the bathrooms as well	
The truth none	
recycling campaign	
recycling	
oil contamination	
Reasonable use of electronic products	
Innova world 2018	
No	
Computers	
The car fair with renewable fuel	
Ninguni	
Only signs in the bathrooms	
Any. People leave the exit windows open and the AC dying. They are imbeciles and the teachers allow it.	
Energy Savings Unit	
Not one	
I have no knowledge	
Recycling	
I dont know	
I dont know	
Garbage collection	

Congress of the Faculty of Industrial Engineering	
Environmental and scholarship projects	
Recycling events, sustainable house projects	
Talks / recycling contests	
Some activities of the faculty of systems	
The green energy media event	
Installation of motion sensors to save energy in the classrooms	
I do not know	
recycling	
We perform a timer to a handler achieving energy savings. the handlers did not turn off from Monday to Friday and managed to turn on Monday at 6:10 in the morning and turn off at 10:30 at night to stay off about 8:15 hours.	
Beach cleaning	
They told me some but I do not remember them	
ZERO	
So far none	
I do not know any at this time	
The truth is that none	
Any	
I know there is an energy saving unit	
none	
The Recycling contests	
The truth I do not know if there are any	
environmental classes	
Any	
So far I have only seen the Forum of electric cars	
Niguno	
there is so far by IEEE	
Training and talks	
FIE Congress	
Savings in bathroom lights	
nothing	
Congress of the FIE	
Any.	
Energy saving	
None, but I know there are some	
Change of luminaires around campus to led lights	
auto lighting room	
Efficiency and Energy Saving Group	
Energy Savings Directorate	
I do not know	
For Earth	
I do not know any	
Planting trees	

Replaces the lights with low consumption lights.

econromenergetico

I do not know



### Do you participate in any of these events?

3 responses

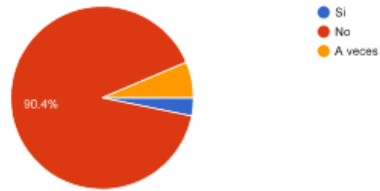

### Any specific event about sustainability and awareness that you would like to see at the university?

182 responses

No (12)
no (12)
none (6)
None (6)
Recycling (4)
Si (3)
I do not know (3)
I do not know (3)
and (2)
I do not know (2)
I do not know (2)
I do not know (2)
recycling (2)
On the use of electronic objects and the way to use light
Energy savings in the classroom dentry
Energy saving and self sustainability
No
Any
I have no idea about these events
I do not know
awareness of the use of services



About saving light	
Energy sustainability	
yes but I do not know any	
nope	
Ranking LEED	
Sustainability and energy saving in domestic equipment.	
Nose	
Emphasize more on saving throughout the university (energy)	
renewable energy	
Yes. Improve the autonomy of air conditioning	
In this moment I dont know	
The energy renovation	
About felling trees	
Honestly, I do not know of any	
artistic	
Risk management	
I do not know any, but if I would like to participate at some time	
save water	
solar sources	
if I would like it but I am not aware of any	
solar panels to reduce the use of electricity	
Recycling pots	
Congresses	
I would have to inform myself	
Nothing	
Energy saving	
Not now	
What to do to consume less	
Maybe some training	
Fine for leaving lights on, windows open, doors open	
Energy savings	
Dissemination of technologies and technological recommendations used in sustainability.	
Referenced to air conditioners	
I have no knowledge	
Saving water.	
I do not know about any	
I could not tell	
everybody	
Certifications in energy saving	
recycling and awareness about energy use	
The energy saving	
I dont know	

Specifically not	
Solar panels	
Sports leagues	
Solar energy	
On recycling and environmental issues	
Recycling projects	
Events on the reuse of waste from building materials, domestic waste,	
Energy saving.	
Better preparation for teachers and find ways to get interested in giving a good class	
Turn off the light of the rooms and bathrooms when no one is.	
Promote more recycling	
Rules on the use of room lights	
I have no information of any event of that nature	
I'm not sure	
solar energy	
I would not know	
place more manejadoras. I would save a few thousand.	
I'm not aware of what options exist	
Smart climate control system	
Beach cleaning	
Encourage students for savings	
Better use of human resources in Panama	
Renewable energy	
Consumption and costs. How we would benefit if we save	
I do not know about any	
Development and maintenance	
Renewable energy and energetic efficiency	
I do not know much about the tena	
Clean and self-sustainable energy cheap	
Energy saving in electronic equipment	
Tours and Workshops	
I do not know any but I would like to know some	
Logging of trees and mining	
Any event that talks about the necessary modifications in the air conditioning equipment of the university.	
I have to see more about the topic to be able to give an opinion	
biogestores energia solar	
I should go through the salons promoting all kinds of January since they only machine-gun us with tests and tests and very little of the other.	
Other (36)	

### Would you be interested in taking classes focused on sustainability?

344 responses

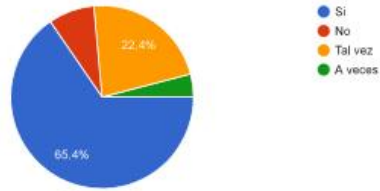

### What is your means of transportation to the university?

348 responses

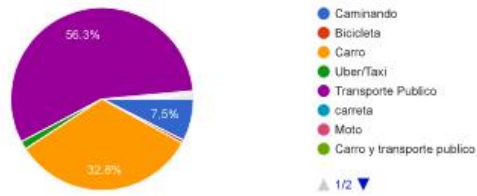

### How many days a week do you use this method?

347 responses

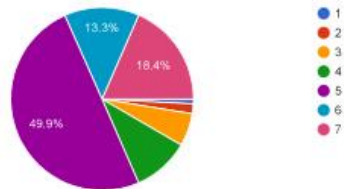



### How would you reduce energy use while on campus?

243 responses



Turning off the lights when they are not used (2)	
Turning off lights or computers that are not in use	
using bicycles	
If media were installed for the production and energy of the sun, it could reduce the use of electricity	
do not use so many daylights	
Turn off the lights of the rooms when there is no one, the Banos also not.	
Not using chargers for cell phones	
Turn off the light, have a portable charger	
turn off lights and equipment when leaving a salon	
turning off the lights when I do not need them	
Setting better standards to convince people	
improve the air conditioning system because there are many rooms with different temperatures and sometimes they are not being used	
Have specific hours when equipment is not used	
Turning off the lights when leaving the bathrooms	
turning off the lices are salons	
Turn off the air as long as it is not being used	
Lowering the air conditioning level	
with voltage regulators	
turning off lights and electronic devices, when not in use	
Implement measures to save energy, shutting down the luxes when I leave the room among others	
Disconnect chargers	
Avoid overuse	
reducing the use of air conditioning	
The use of air	
Turning off the lights and controlling the air conditioning	
turning off the lights that will not be used	
Do not leave the thing on	
and	
Using when important energy is necessary	
Charging my cell phone at home and turning off lights in living rooms and bathrooms when not in use	
Use less electronic devices.	
Not charging the cell phone	
Optimizing the use of AC	
turning off the lights in the bathrooms, and in rooms where they are not used.	
With the least use of light	
Turn off the lights	
Turning off the lights when leaving the room	
Reducing the iso of mobile devices pc among others besides using the installations to conscience	
turning off equipment that is not in use	
Trying to save energy if I'm not using it at the moment	
Automation of air conditioning is the most important	
turning off the lights in the living rooms and bathrooms when they are not used	

I do not know	
using less time the cell phone to not charge it periodically	
Turning off equipment when not in use	
Maintaining electric power care and turning off electronic equipment when not in use	
Turning off the lights when you are not in the bathroom	
Turning off the lights in the rooms when there is no one and avoiding connecting electronic devices for a long time.	
With solar panels	
Turning off the lights of the disused classrooms	
Turning off switches when not using	
Reduce the iso of electric power	
Turning off devices that are not in use	
no	
Turning off lights	
Turn off the lights when they are not using	
I dont know	
turning off equipment that is not being used	
turning off the lights when necessary. installing sensors in the rooms	
turning off lights when not being in the lounges	
Implementation of bicycles and solar lamps	
I can not think of anything	
I have idea	
using the lights in the moments that are necessary only.	
automatic lights	
no utilizansolos inesesariamente	
turning off lights when leaving the room	
renewable generation	
turning off the light when leaving the room. By lowering excessive use, air conditioners	
turning off lights and equipment that are not being used	
placing solar panels	
Use less electronic devices to reduce energy consumption	
Taking consideration and turning off lights and others	
Closing the windows while the air conditioner is in use	
Making students aware of the use of the campus	
Using less electronic equipment	
Turning off classroom lights when they are not in use	
Do not use them	
Don't know	
Cycling	
Loading my equipment at home?	
In addition to equipment with better efficiency (if possible) simple habits such as "if you open it, close it". Basic	
Encourage student projects applicable to the university.	
Turning off lights in rooms that are not used	

Changing the method of lighting lights by sensor.	
Turning off lights to reduce that load, closing doors of refrigerated rooms to reduce the load of the same.	
Remove the lights in the bathrooms at night :)	
Smart appliances	
Lowering the temperature of the air conditioner when necessary.	
Turning off what I do not use	
teaching people	
LED bulbs, automatic switch-off of lights under sensor, air conditioners with temperature regulators under motion sensors	
carrying my cell phone and laptop loaded from home, or not take them	
Turning off lights as long as they do not see use	
Power Regulators	
nose	
Other (134)	

## APPENDIX F: README

This is the README.txt file in the folder with the code and libraries that will be transferred to the UTP sponsors and students.

Sensor node information:

All the libraries used will be included in a .zip file

Low-power mode:

This uses an external real-time clock with the RTCLibextended.h library.

You can refer to the links below for how low-power mode works:

<https://github.com/FabioCuomo/FabioCuomo-DS3231>

<https://www.instructables.com/id/Arduino-Sleep-and-Wakeup-Test-With-DS3231-RTC/>

The only types of alarm needed to work with RTC.setAlarm() to adjust the interrupt are

ALM1\_MATCH\_SECONDS and ALM1\_MATCH\_MINUTES.

RTC.setAlarm() and alarmInterrupt(1, true) are used at the end of both setup() and loop() for an initial alarm setup and when the board wakes up, it sets another alarm before going to sleep.

For setAlarm() here are a couple examples:

RTC.setAlarm(ALM1\_MATCH\_SECONDS, 0, 0, 0, 0) will give you a reading every minute when the time hits

1:00:00, 2:00:00, 3:00:00, 4:00:00

RTC.setAlarm(ALM1\_MATCH\_SECONDS, 20, 0, 0, 0) will give you a reading every minute when the time

hits 1:00:20, 2:00:20, 3:00:20, 4:00:20

RTC.setAlarm(ALM1\_MATCH\_MINUTES, 0, 0, 0) will give you a reading every hour when the time hits

1:00, 2:00, 3:00, 4:00

RTC.setAlarm(ALM1\_MATCH\_MINUTES, 20, 0, 0) will give you a reading every hour when the time hits

1:20, 2:20, 3:20, 4:20

Sensors:

There are a couple functions with certain constants to receive the correct values for the sensors. Here are the links for the reference code:

[http://wiki.keyestudio.com/index.php/Ks0196\\_keyestudio\\_PM2.5\\_Shield](http://wiki.keyestudio.com/index.php/Ks0196_keyestudio_PM2.5_Shield) - Particulate Matter Sensor

[https://www.dfrobot.com/wiki/index.php/Gravity:\\_Analog\\_Infrared\\_CO2\\_Sensor\\_For\\_Arduino\\_SKU:\\_SE\\_N0219](https://www.dfrobot.com/wiki/index.php/Gravity:_Analog_Infrared_CO2_Sensor_For_Arduino_SKU:_SE_N0219) - CO2 Sensor

<https://www.electroschematics.com/11291/arduino-dht22-am2302-tutorial-library/> - Temperature and Humidity Sensor

#### PM Sensor:

Particulate matter measures dust concentrations so it usually gives the reading: 0.00

#### CO2 Sensor:

This sensor is significantly hard to work with, but it was the only viable option for us to capture 0-5000 ppm range because for CO2, correct readings should be in between 200-500 ppm outdoors and maybe slightly higher for indoors.

For calibration, we used the manual calibration method here:

<http://www.doctormonk.com/2018/03/review-and-test-of-mh-z14a-ndir-co2.html>

Keep in mind that this calibration should be done on the power source that you are intending to use because the readings are calculated from the voltage value that corresponds to the `analogRead()`. We were using a battery bank and could not figure why it was giving wrong readings when connected to PC. It's because they have different power supplies.

This sensor also needs 1-2 minutes to heat up and get precise readings. That's why there is a for loop with a dummy reading call before collecting 10 data points to provide a buffer for outlier data points. The reason is because we experienced voltage spikes from the sensor such as 400ppm, 400ppm, 400ppm, 680ppm, 400ppm



#### LoRa:

In this part of the code, LoRa module is only used to send a string packet with the readings formatted to a string before being sent.

We also constrained the readings above 1000ppm to send "999.99 ppm" because any reading above 1000ppm for outdoors is most probably unrealistic

<https://github.com/sandeepmistry/arduino-LoRa/blob/master/API.md> - LoRa library information

#### ESP32 information:

This code is uploaded to a NodeMCU-32S board that integrates the ESP32 WiFi IC.

#### Uploading data from the ESP32 to a Google Spreadsheet:

The code utilizes a third-party service and API known as PushingBox. I originally intended to use a similar service called IFTTT to upload data to a google spreadsheet but switched to PushingBox because it was much more customizable. The board first connects to a local WIFI network in the setup function. Then it calls the postData function to upload to the spreadsheet every time data is received through the LoRa radio. A link on how to implement this system is included below.

<https://www.hackster.io/detox/transmit-esp8266-data-to-google-sheets-8fc617>

#### Using the LoRa radio module:

The ESP32 board is connected to an XL1278-SMT radio module. This radio implements LoRa protocol for long range communication with a carrier frequency of 433MHz. The radio is initialized in the code by defining SS, RST, and DIO0 pins based on which of the ESP32 digital I/O pins they are connected to. The radio uses an SPI interface to communicate with the ESP32, and these SPI pins (MOSI, MISO, and SCLK) must be connected to their corresponding SPI pins on the ESP32. The radio must be powered by the ESP32's 3.3V output.

In the setup function, the LoRa is initialized with `LoRa.setpins`, and `LoRa.begin`. Finally, a communication channel is chosen with `LoRa.setSyncWord`. Any hexadecimal value from 0x00 to 0xFF can be input into this function. Radios must have the same sync word to communicate with each other. The loop function continually polls the radio to see if a data packet has been received with `LoRa.parsePacket`. This function returns true if the radio has received a packet. When a packet is received, it is read with `LoRa.readString` because the packets are transmitted in string format. This string which contains four data values is stored to a string `LoRaData` and then broken apart with `substring` to store each individual value in its own string so that it can be utilized by the `postData` function. For testing purposes, the values are printed to the serial monitor along with the RSSI (received signal strength indicator). I experienced many problems with getting good reception inside the building through exterior concrete walls. For the best results, I recommend the radios be in direct line of sight of each other with their antennas aligned. Furthermore, for reliability purposes, I included a software restart at the end of the sequence. A link on how to wire the radio and implement this system is included below.

<https://randomnerdtutorials.com/esp32-lora-rfm95-transceiver-arduino-ide/>

#### Problems We Faced and Solutions:

- In order for the Arduino board to fit inside the Libelium box, we had to cut out a certain region on the Arduino. Refer to the prototype.
- Additionally, we had to replace the USB connection with another USB-to-USB connection by soldering it to the Arduino because the default connection port was too bulky to fit.
- We used silicone to attach the sensors to the box. We also used it to strengthen the LoRa module connection between wires. The DHT (Temperature and Humidity) and particulate matter sensors are attached next to the holes of the box and the CO2 Sensor is attached at the side outside the box because it is waterproof.

- We had to drill our own holes in order to mount the board. The mount is a wood piece inside the Libelium casing and you can take it out to mark the spots for the Arduino and drill holes to screw the board with those holes.
- The USB connection that we are using is covered by a cap and the connection can need a little jiggle on the cord possibly due to small soldering errors.
- The power bank is relatively good at powering an Arduino, especially when used with low-power mode for the Arduino to wake up and submit hourly readings. It can last a long time.
- Be careful about the sensor sensitivity! Make sure further additions and replacements have enough accuracy to detect slight amounts in air.
- The CO2 sensor that is currently used is not the easiest to work with because it needs some time to heat up and it is hard to calibrate.
- There are probably better materials in terms of casing and the sensors to build a more reliable version. We used the existing Libelium casing to save time and the sensors we had could have better alternatives if we had the time to wait for the shipping and assemble the parts.