



# Remote Design of an Outdoor Kitchen

By: Zacharey Almy, Nick Cauley, and Timothy McDonald



Turn Back Time



# Remote Design of an Outdoor Kitchen

## The Team

Zacharey Almy

Nicholas Cauley

Timothy McDonald

## Advisors

Professor Derren Rosbach

Professor Elisabeth Stoddard

Turn Back Time Executive Director and Founder

Lisa Burris



Example of an Outdoor Kitchen

WPI students must complete a junior-year research project, typically at an international site. Some students are unable to engage in a residential project due to responsibilities close to campus. Turn Back Time (TBT) is a farm and nature-based organization, 10 miles from WPI. TBT is building a residential yurt village to support these students. This project aims to design and build an outdoor kitchen to support the village, as well as the personal, educational, and professional growth of WPI students.

# Acknowledgements

Our team would like to recognize the following people for their contributions, assistance, and patience while working on our project and dealing with COVID-19. Our team would like to extend our gratitude to everyone who made our project successful.

Professor Elisabeth Stoddard, IQP advisor

Professor Derren Rosbach, IQP advisor

Lisa Burris, Executive Director, Turn Back Time, Inc.

Professor Leslie Dodson, Co-Director, Global Lab

Professor Jason Davis, ID2050 advisor

Mario Alagna, Architect, Summa Development

Edward Ledger, Pergola Owner, Turn Back Time Donor

Conor Stedman, Principle, Lead Director, Appleseed Permaculture

# Authorship

The following document has been through multiple editing stages and versions. It has been equally written and edited by all team members, and has also been approved by our advisors. All team members were in agreement on all edits and revisions made to the report before changes were made.



Walking on a Wooden Trail at  
Turn Back Time Farm

# Meet the Team



My name is **Zacharey Almy**, and I am from Stow, Massachusetts. I am a mechanical engineering student at WPI, and work in the construction trade. Through working on the project, I learned about making creative solutions to accommodate a budget, which I have not previously done working in construction. Working remotely was another challenge which I had not faced before. Working remotely gave me a greater appreciation for traditional teamwork, but it also allowed me to develop new tools to work as a team in the unpredictable situation of the COVID-19 pandemic.



My name is **Nicholas Cauley**, and I am from Milford, New Hampshire. I am an electrical engineering student at WPI. I am involved in Intramural sports at WPI, as well as coaching youth sports teams. Through working on this project, I was able to better understand how to work in a team environment with different skill sets in order to accomplish a common goal. Working remotely was another learning point that came of this. I am proud of myself and my teammates for how we adapted to the circumstances in order to provide TBT with an outdoor kitchen.



My name is **Timothy McDonald**, and I am from Walpole, MA. I am a chemical engineering student at WPI. I am involved in the Men's Varsity Swim Team and the Lambda Chi Alpha fraternity. Through working on this project, I was able to learn new design and construction skills that I previously did not possess. This experience also provided a new learning curve for me, while working remotely due to COVID-19. I am very grateful to learn new things and overcome new challenges that would not have been presented with another project.

# Table of Contents

<b>Title Page</b>	1	Rocket Stove	23
<b>Abstract</b>	3	Pizza Oven	24
<b>Acknowledgments</b>	4	Wash Station	25
<b>Authorship</b>	5	Child Safety Precautions	26
<b>Meet The Team</b>	6	New England Weather	27
<b>Table of Contents</b>	7	Local Wildlife	28
<b>Executive Summary</b>	10	Building techniques for Environmental Challenges	29
<b>Introduction</b>	13	Building Safety Considerations	30
Need for an Outdoor Kitchen Area	14	Nature Based Learning	31
Dealing With COVID-19	15	<b>Methodology</b>	32
Our Remote Workspaces	16	Assessing Outdoor Kitchen Appliances	33
<b>Background</b>	17	Supplying and Managing Water	35
Turn Back Time Stakeholders	18	The Outdoor Kitchen and Natural Environment	36
WPI Project Center Basics and Statistics	19	Weather Resistant Materials and Methods	38
Farm Stay Projects	20	Waste Management	40
Turn Back Time Community	21	Immersive Educational Environment	41
Outdoor Kitchen Design Considerations	22	<b>Results and Findings</b>	43
Cooking Amenities	22	Kitchen Appliance Findings	44

# Table of Contents

Rocket Stove	45	Phase Five	81
Pizza Oven	49	Donations	82
Kitchen Covering	55	Budget	84
Improving the Kitchen's Longevity	59	Initial Proposed Budget	85
Material Decisions (Wood)	59	Final Proposed Budget	86
Wood Preservation Techniques	62	Bringing It All Together	87
Waste Management	69	Final Conceptual Design	87
Composting Methods	70	Cabinets, Countertops, and Sink	88
Subpod Grow Bundle	71	Rocket Stove	89
Immersive Educational Environment	72	Pizza Oven	90
Six Major Teaching Points	73	Composting Bin	91
Stem Sample Activity - Budgeted Salad	74	Grill	92
<b>Deliverables</b>	75	Pergola	93
Design Stages	76	Pergola Building Instructions	94
Phase One	76	Patio	95
Phase Two	77	Thank You	96
Phase Three	79	Work Cited	97
Phase Four	80	Images Cited	100





Outdoor Kitchen Proposed Location



Turn Back Time Sign



Child at Turn Back Time

Turn Back Time (TBT) is a non-profit organization located on a 58-acre farm and nature education center in Paxton, Massachusetts. TBT offers programming for children and adults to learn and health through nature, with a focus on supporting those in at-risk populations. This includes those who are neurodiverse, on the Autism spectrum, children in foster-care, and those who have experienced trauma. TBT also provides educational research opportunities for WPI students. Lisa Burris is in the process of building a residential yurt village to offer additional, high impact educational programming and long-term research opportunities. Lisa Burris has asked our team to design and build an outdoor kitchen to support the village and provide enhanced learning opportunities, if possible with the restrictions of COVID-19. This added attraction will also increase donor appeal and interest in families' interest in sending their kids to the farm. In order to fulfill the goal of designing a fully immersive outdoor kitchen for people of all ages at Turn Back Time, our team has created the following five objectives:

1. Research potential outdoor kitchen appliances.
2. Figure out the most efficient way to supply the kitchen with running water.
3. Determine how to improve the longevity of the outdoor kitchen.
4. Create a management system to reduce waste generated by the outdoor kitchen.
5. Create an immersive environment for college students and an educational environment for children to use during their time at TBT farm.

## Executive Summary: Methods

In order to best fulfill all objectives, we reviewed articles on waste management in outdoor kitchens, types of wood used and associated preservation methods, educational aspects of cooking and preparing food, and plumbing and electricity for outdoor kitchen.

To further expand our understanding of suitable appliances, wood types, kitchen coverings, and engineering and construction methods, we interviewed subject experts from a variety of fields including: Edward Ledger (pergola owner and engineer), Mario Alagna (developer and architect), Connor Stedman (agricultural planner), and Lisa Burris (TBT owner). A survey was sent to Lisa Burris to distribute to a variety of TBT stakeholders to understand what they feel is necessary for and beneficial in an outdoor kitchen at TBT. Stakeholders include the parents of children who attend programs at TBT, members of the board of directors, and workers at the farm. We also completed decision matrices to help determine which types of wood and wood preservation methods are best in this context, with a focus on cost, durability, aesthetics, and means of transportation to the farm.



Interviews



Surveys

Through our data collection and analysis, we recommend that a rocket stove, pizza oven, grill, and sink will be the appliances included in the kitchen. The kitchen area will be covered with a pergola, and all cedar and pressure treated wood used will be further treated using wood stain and polyurethane methods. We received a number of donations to support TBT in this project, including granite countertops, a rocket stove, and cedar wood. One member, Nick, was able to use a workshop to build the cabinets for the kitchen. These efforts saved TBT almost \$5,000 and a dozen hours of labor. Finally, Google SketchUp and Solidworks designs, as well as build instructions, will aid the creation of this kitchen, as soon as TBT allows volunteers back on the farm.

The construction of an outdoor kitchen at Turn Back Time will not only make it possible for students residing in the yurt village to prepare meals, it will also create opportunities for students to develop close relationships and a cohesive community. The outdoor kitchen will include educational aspects to help teach the children grades K-5 at the farm about science, technology, engineering, and math (or STEM) through cooking and food preparation. Finally, the kitchen will also benefit at-risk youth attending therapeutic retreats at the farm, as well as wellness programs for adults.



Donated Cabinets



Donated Granite

# 1. Introduction

“Turn Back Time’s mission is to help people recognize nature’s ability to teach and heal with a commitment to offering programs to underserved populations.”



Lisa Burris  
Turn Back Time Executive Director

## Turn Back Time Farm



Turn Back Time Welcome Sign



WPI Students Visiting 'Three Little Pigs at Turn Back Time

Turn Back Time (TBT) is a 58-acre farm and nature education facility focused on environmental teaching and healing through nature. In addition to offering programming for children 3-13, TBT has offered research opportunities to WPI students for the last 3-years. While most WPI students travel abroad for their Interactive Qualifying Project (IQP), a required research project in the junior year. About 200 students per year must complete their project on or close to campus. Lisa Burris, who is the Executive Director at TBT, wanted to continue to host IQP and MQP projects at TBT, but proposed a new farm stay program to enhance students' learning and research experience. In order to complete this goal, Ms. Burris is constructing a yurt village, with the support of the WPI 2020 Class Gift. However, the village also needs facilities for bathing, cooking and more.

## Need for an Outdoor Kitchen Area

Ms. Burris asked our team to research, design, and build (if possible) an environmentally sustainable and aesthetic outdoor kitchen to support the future residents of the yurt village. Research shows that preparing, cooking, and eating food together can create strong bonds and community (Gurwitt, 2009). These bonds and community will support students who are off-campus conducting research, as well as at-risk children, youth, and adults who are at the farm for nature-based therapeutic and educational programming. The kitchen will help TBT in hosting large outdoor events such as weddings, birthdays, and corporate events. This will then result in increased revenue and popularity of TBT. In order to successfully complete this project, our goal is to provide a fully functional outdoor kitchen equipped with running water, a stove, and a waste management system which can be used by WPI students and other stakeholders at TBT for years to come.

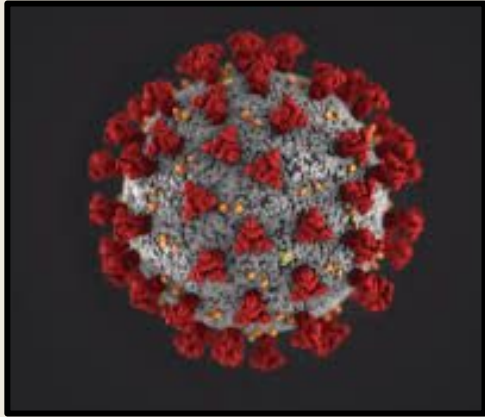

COVID-19



Zoom Video Conference Software

## Dealing with COVID-19

Due to the COVID-19 outbreak, WPI made the decision to move all remaining spring 2020 courses and projects to an online setting. This decision was made in accordance and recommendations from both the federal and local state governments. Our group then had to adapt to the situation and work remotely from home, conducting all meetings, interviews, and site assessments through ZOOM. The team originally hoped to regroup and build after the initial “stay in place” order was planned to be lifted on May 4, 2020. This order was extended until May 18, 2020, however, and the team then decided to potentially build the outdoor kitchen at a later date. Despite the restrictions, the team was able to get key donations and build the cabinets and frame, which allowed us to contribute to the build despite not having access to the farm.

# Our Remote Workspaces

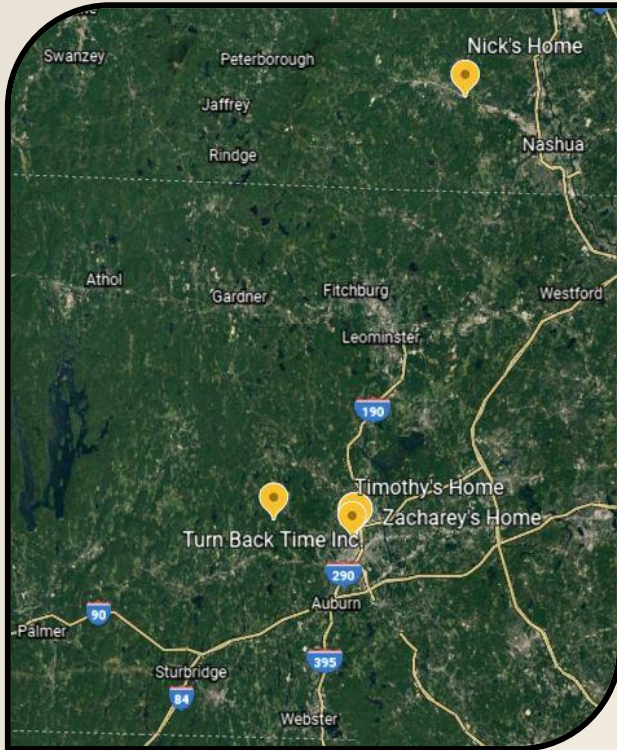

**Nick's  
Workspace**

Milford, NH



**Zacharey's  
Workspace**

Worcester, MA

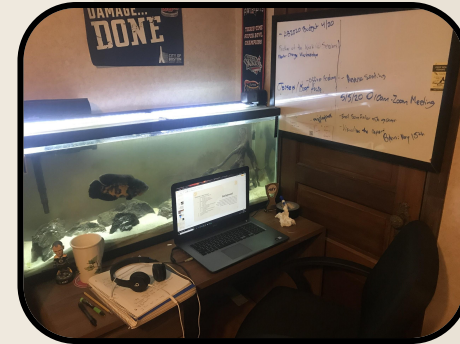

**Timothy's  
Workspace**

Worcester, MA



## 2. Background

This section provides a detailed description of the background information we research, focused on different aspects of outdoor kitchens. The information in this section was used to direct the selection of research methods, which we discuss in the Methodology section.

### **In this Section:**

Turn Back Time Stakeholders

Lisa Burris

Farm Stay Projects

Turn Back Time Community

Outdoor Kitchen Design Considerations

Cooking Amenities

Wash Station

Child and Handicapped Safety Precautions

New England Weather

Local Wildlife

Building Techniques for Environmental Challenges

Massachusetts State Building Regulations

Nature-Based Learning

# Turn Back Time Stakeholders

## Lisa Burris

The Executive Director of TBT, Lisa Burris, has been running educational programs at the farm in Paxton, MA since 2012. Through Lisa's two children with special needs, she came to the realization that outdoor activities had an enormous educational impact on her kids. This inspired the idea of a non-profit educational farm for children of a variety of age groups (Turn Back Time). To further strengthen her knowledge of outdoor education, Lisa went on to also pursue and receive a master's certificate from Antioch University in May 2017.



Lisa Burris with Donors



Future Bathhouse to be Built at TBT

Various additions to the farm through donations, volunteering opportunities, and WPI projects have inspired more sponsors and families to support Lisa's operation. An aesthetically pleasing, fully functional, and educational kitchen space will be an attraction to all other stakeholders as explained below, which increases outside interest in the farm. The addition of an outdoor kitchen will have a lasting impact on Lisa financially because it will increase appeal from potential donors as well as families interested in sending their children to various programs at TBT. An outdoor kitchen will be a centerpiece at TBT not only from a social gathering standpoint, but will inspire future stakeholders of TBT to invest more time and resources to develop the farm. Lisa, herself, envisions the kitchen as something that people will see and be drawn to.

## WPI Project Center Basics and Statistics

All students at WPI are required to complete two large scale projects during their collegiate careers in order to graduate and those two projects are called Interactive Qualifying Project (IQP) and Major Qualifying Project (MQP). The Farm Stay project center will be a project center mainly focused for IQP's, but MQP's are not excluded from working here either. WPI has students complete an IQP because it, "Solves a problem at the intersection of science, technology, and culture, and emphasizes the need to learn about how technology affects people, societal values, and structures". (WPI, 2019) Most IQPs are completed through WPI's 50+ global project centers and as of 2017, 72 percent of WPI students completed their IQP at one of these centers. WPI, however, would like to increase this off-campus completion percentage to 90 percent by 2020 to increase the number of experiences had by students while immersed in their project center. WPI aims to do this to allow students to feel more connected to the communities that they are serving to create a more personal relationship with the work that they are completing. However, WPI does recognize that many students may not be able to go abroad due to financial burden, family obligations, and others on campus commitments (WPI, 2019).

**31**

**countries with  
project centers**

WPI (2020)

**#1**

**School for a Scientist  
to Study Abroad**

Popular Mechanics (2017)

**50+**

**global project centers on  
six continents**

WPI (2020)

**1,030**

**students completed an  
off-campus project (2018-2019)**

WPI (2020)

**Top 10**

**most popular study  
abroad programs**

The Princeton Review  
(2017-2018)

**14,500**

**undergraduate students with  
off-campus project experience**

WPI (2020)

## Farm Stay Projects

To combat this common difficulty with travelling abroad, Professor Stoddard, Professor Rosbach, and Lisa Burris proposed that starting in the spring of 2021, WPI's IQP and MQP projects at TBT will be considered off-campus projects, with the addition of Yurt Village at TBT (Lisa Burris). The plan is to construct a cluster of four residential yurts, a central yurt with library resources, and a sixth yurt for meeting will make farm stay a possibility in the near future (Turn Back Time). WPI students will then be able to live full time at TBT to become immersed in their project site. TBT is relatively close to WPI so students have the luxury to travel to and from campus as needed for any extracurriculars, ROTC commitments, and jobs that students may have. This will place no additional financial burden on students, thus making the Farm Stay project center an attractive option to students under these circumstances. IQP and MQP projects at TBT have been based on the common theme of improving TBT through various construction projects to improve the overall experience of all stakeholders at TBT (Lisa Burris). Through the Farm Stay program students will become more involved and connected to the mission of TBT, with the hopes of better project outcomes in the future.



Exterior Replica of Yurt Village



Interior Replica of a Residential Yurt

## Turn Back Time Community

The TBT community who will benefit from an outdoor kitchen include: children who attend the farm's programs and their families, the staff such as counselors and Lisa, people attending various on-site retreats, and volunteers donating their time towards improving the farm. The immersive environment will be catered to people of all age groups, and a selection of multiple kitchen appliances will allow for many types of food to be prepared and cooked in the area. Lisa Burris has stated that all who attend the farm will be welcome to use the area as they wish, so the variety in people who will use the kitchen was taken into consideration.



Volunteers



Children and Families



Retreats



Staff

# Outdoor Kitchen Design Considerations



## Cooking Amenities

In order to have an outdoor kitchen with appliances that can cook food properly and efficiently, our group needed to research different methods for cooking in an outdoor setting. We needed to find appliances that can cook food and withstand New England weather, so they will not deteriorate quickly over time. This is to ensure the sustainability and longevity of the outdoor kitchen.

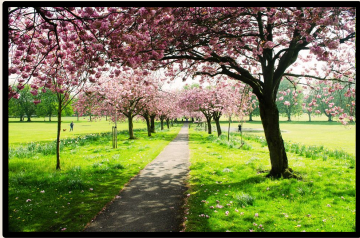

Spring

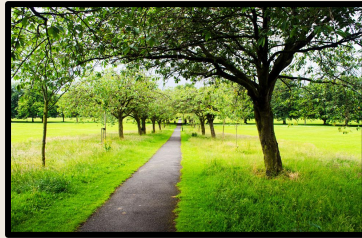

Summer

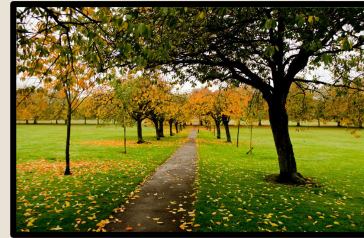

Fall

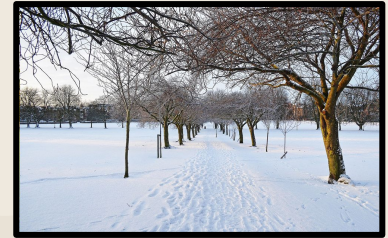

Winter



# Rocket Stove

A rocket stove is a high temperature stove which uses small diameter wood fuel (Rocket Stove, 2006). Rocket stoves provide users with more efficient cooking methods by burning cleaner, therefore requiring less fuel (wood). This is done by using an internal chimney to ensure efficient combustion by creating a strong draft making for more efficient combustion. Also, a narrow passage is used to reduce heat loss, which then allows for more of the heat to be used towards cooking. Furthermore, rocket stoves which are insulated additionally reduce heat loss (Rocket Stove, 2006). This seemingly simple design can cut down on fuel consumption as much as fifty percent compared to cooking over an open campfire flame (Rocket Stove, 2006).

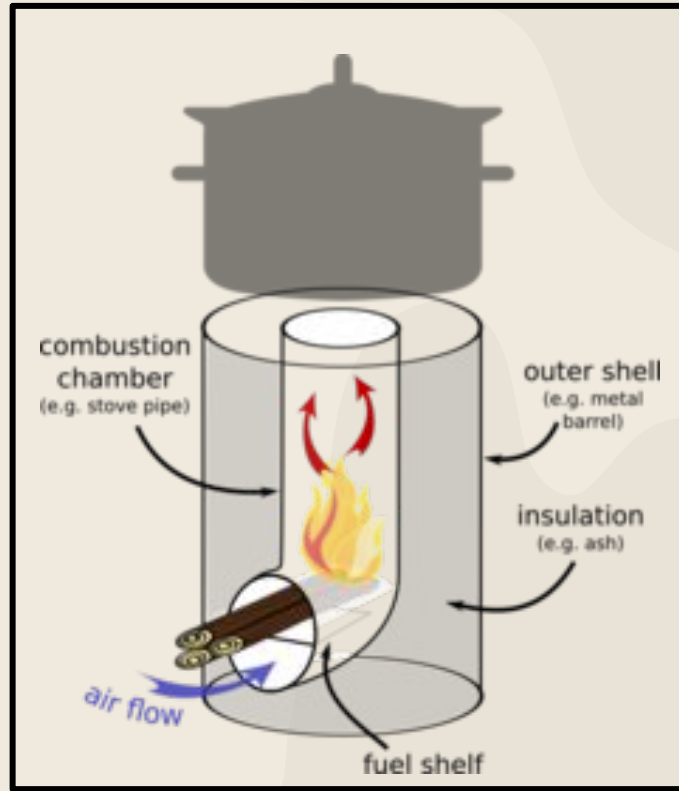

Rocket Stove Design

A rocket stove is a hands-on appliance that the children, Farm Stay students, retreat goers, and even potential cooperate function attendees will be able to learn from and possess a new unique skill that they previously did not have. Lisa desires a rocket stove at TBT because it can cook a wide variety of food while acting as a great teaching point to all who use it. In a similar fashion to a campfire, fueling a rocket stove with wood provides more of an outdoor and interactive feel. The aesthetic appeal of this appliance is yet another positive, as the unique design will attract the kitchen's users to learn more about it. One minor concern surrounding this appliance is that a rocket stove can pose a safety risk to children within close proximity. Counselors and adults will need to keep a close eye on all children while a flame is lit.

# Pizza Oven

A pizza oven is a traditional but also very unique way of cooking pizza for both small and large groups of people. A pizza oven is a tool that is simple to operate but caution needs to be used when in operation. A pizza oven is typically constructed on a flat platform with a large dome encapsulating the cooking surface. Wood logs are then loaded to the back or to the side of the dome and ignited to provide a heat source. The temperature of the pizza oven can then reach temperatures of 700 - 800 degrees fahrenheit. This high temperature range allows for pizza to be cooked evenly and thoroughly at a reasonable amount of time, depending on the size and thickness of the prepared pizza (Pizza Planet, 2018).

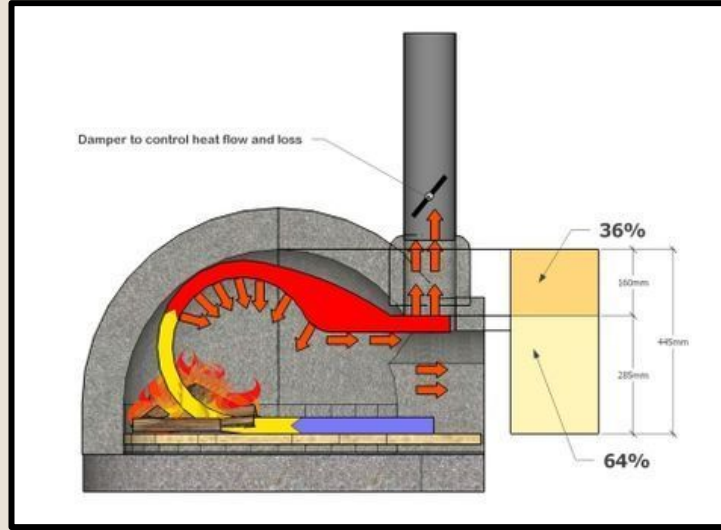

Pizza Oven Design

An addition of a pizza oven will hopefully provide two new exciting aspects to TBT. The first being is that it is a fun and exciting new educational aspect that can be brought to TBT. The process of preparing a pizza from raw ingredients fresh from the garden, to then actually cooking it can allow the educators at TBT to teach the children about fire safety and how different ingredients cook faster than others.

This is a hands-on approach that the children, Farm Stay students, retreat goers, and even potential cooperate function attendees will be able to learn from and possess a new unique skill that they previously did not have. Lisa desires a pizza oven at TBT to create lasting memories and to develop unique cooking skills.

A pizza oven will also provide a very aesthetically pleasing look to the Outdoor Kitchen. A pizza oven is not something many people at home see everyday and to bring something unique and exciting to TBT will increase a sense of community. Working together to grow crops at TBT, wash and prepare ingredients, and then produce a final product connects many different areas of expertise and brings the community together for a common goal. People will want to come to TBT to enjoy the pizza oven and the different cooking experience it could provide .



## Wash Station

When cooking with food, washing hands, fruits and vegetables, and dishes is a necessary task. Water used for the outdoor kitchen sink will most likely come from one of three places, rainwater, well water, or city tap water. Well-water is known as hard water, this means it contains many minerals with it (Stringer, 2016). The most common way to treat this is by using a water softener that uses salt to rip the water of its minerals. Rainwater is naturally soft as it has not passed through the ground and collected minerals, thus the use of a carbon activated filter should be sufficient for cleaning the water (Stringer, 2016). A carbon activated filter will remove any impurities from the water making it able to be safely consumed. Lisa has also mentioned that tap water from the proposed bath house could also be used to supply the kitchen with running water. The wash station should also be accessible to everyone, and a built-in step stool could be used to make the sink easier to use for children. Also, the sink should be wheelchair accessible, this could be accomplished with a detachable nozzle to bring the faucet closer to the handicapped people (ADA Guidelines to Designing A Wheelchair and Handicap Accessible Kitchen, 2020). A wash station with running water is a key aspect to any outdoor kitchen area which allows for users to cook and prepare meals.

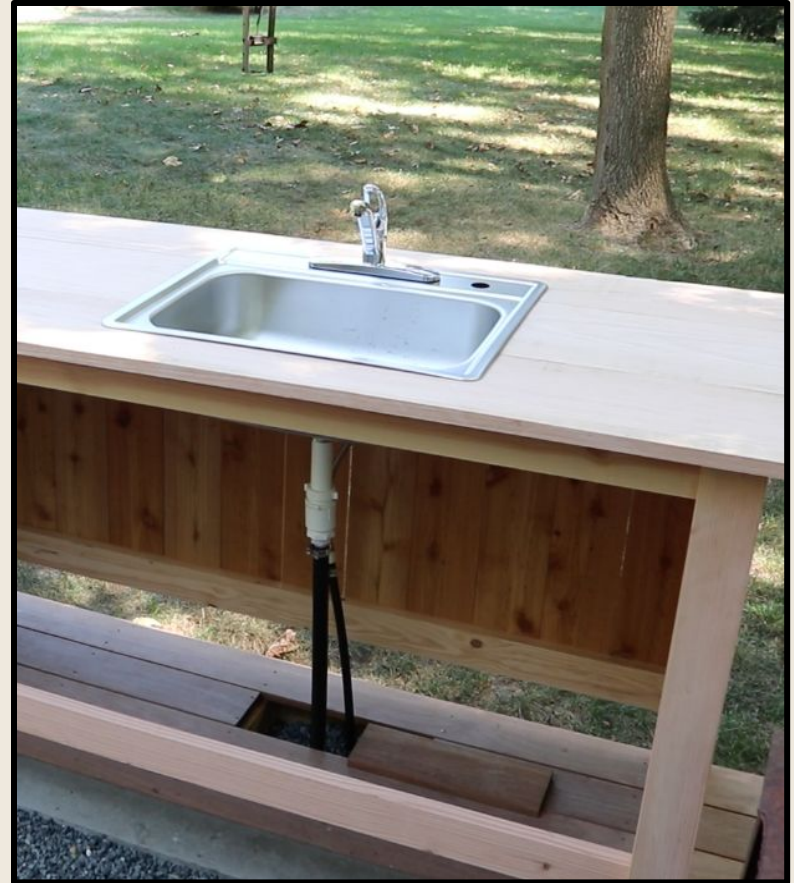

Example Wash Station

# Child Safety Precautions

Due to the nature of the programs supported by TBT, including some for young children, it is crucial to consider safety for all when implementing an immersive and inclusive outdoor kitchen environment. Although some safety hazards like exposure to radiating heat and slippery surfaces are inevitable, it is important that safety is always taken into consideration when designing and developing materials to be used at an educational facility. According to the National Safety Council, falls account for nearly one-third of non-fatal kitchen injuries in the United States (National Safety Council, 2020).

The best way to protect from the potential of a falling incident is to make an organized kitchen with many places to store excess utensils and tools to ensure that nothing is left on the ground (National Safety Council, 2020).

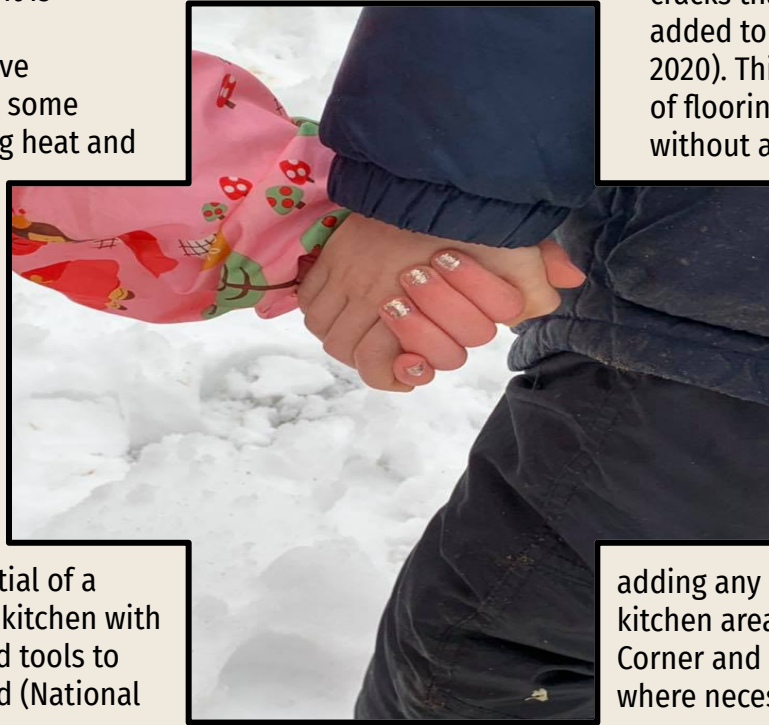

Helping Hands

It is also important to have limited cracks, and cracks that are limited in size, in any flooring added to the area (National Safety Council, 2020). This would mean that any bricks or slabs of flooring material used must be close together without any significant distance between slabs,

which could be a tripping hazard. Safety latches and locks for cabinets and drawers to help prevent poisonings and other injuries are recommended in kitchens to ensure that children cannot get their hands on potentially dangerous devices or substances (National Safety Council, 2020). These will be considered when

adding any drawers or cabinets to the outdoor kitchen area, as safety is ultimately a top priority. Corner and edge bumpers will also be considered where necessary in the event that a sharp edge is necessary on a preparation table or other kitchen appliance.

## New England Weather

Comparatively, between the different regions of the United States of America, the New England region is notorious for extreme weather conditions. Due to close proximity to oceans, varying elevations caused by the Appalachian Mountain Chain, and a unique latitude New England possesses a wide range of weather types. New England experiences a wide variety of weather, but Paxton specifically endures nor'easters, ice storms, heavy rainfall, and some periods of drought (Zielinski, G. A., & Keim, B. D., 2005).



Snowy Winter at TBT



Sunny Summer at TBT

Due Paxton's central Massachusetts setting, nor'easters and ice storms will play a large part in design factors that need to be accounted for. These two types of storms are frequently known for taking down power lines and trees, as well as shutting down roadways and causing serious delays (McPherson, A., 2014). At TBT, a greenhouse constructed during the 2019-2020 school year has unfortunately collapsed due to these weather types. Heavy rainfall is also a potential issue because the kitchen will need to be used during the spring, summer, and fall months. This can lead to cooking fires being extinguished and cooking prep areas becoming oversaturated. To combat this potential issue our team will try to design coverings and methods to ensure that cooking flames are not extinguished and prep areas are kept dry and clean from debris, while taking into account wind forces and snow loads.

## Local Wildlife



Black Bear

Located in a heavily forested region, Paxton also has a wide variety of local wildlife that can pose potential hazards to an outdoor kitchen. The largest and most recognizable of Paxton's local wildlife would have to be the Black Bear. MassWildlife has faced issues in the past with controlling Black Bears in Paxton, Massachusetts and sends out friendly reminders to the community as to how to deal with the bears (Welcome to the Town of Paxton, 2020). The main problem being when food is left out and will then attract bears into an area settled with residents of the community. Black Bears are typically more skittish than other types of bears, but are still known to have attacked dogs and even humans when feeling threatened (Welcome to the Town of Paxton, 2020). Other types of wildlife that are also prevalent to Paxton that our project needs to be aware of are: Bobcats, Coyotes, Weasels, Foxes, Opossums, Raccoons, and Skunks (Division of Fisheries and Wildlife, 2020). All these types of wildlife are also prone to break into food storage areas and raid food that would be used for cooking purposes.

## Building Techniques for Environmental Challenges

In order to successfully combat the issues of inclement weather and critter control, certain building techniques needed to be implemented into the design of the outdoor kitchen. In terms of protecting the kitchen from weather, an option can be to use a covering or awning to provide a covered area. This would allow students to escape torrential downpours and relieve the kitchen from excessive snowfall and allow it to remain accessible. The supporting structure for the covering would need to be fortified enough to withstand the weight of accumulating snow and ice, and short enough to be able to access the top of in the event it needs to be cleared off (Whirlwind Team, 2018). To prevent the issue of wildlife raiding the kitchen Lisa informed the team that a separate food storage site would be utilized.

This new storage site will be the new bathhouse planned to be constructed at TBT by 2021 (Turn Back Time). The benefit to this would be how it is an enclosed setting making it critter proof and would offer refrigeration units. The downside to this, however, is that it will not be built until almost a full year after the tentative completion of the outdoor kitchen project. Until the new building is completed, a temporary option will need to be considered. Another storage option is within a cabinet space that can be implemented in the kitchen area itself. This will make storage much easier, as the storage space is simply within the kitchen area itself as opposed to a further location.

# Building Safety Considerations

When designing and constructing an outdoor kitchen, it is important to practice good safety precautions to ensure a safe environment for all users. In fact, “Safety is the most important aspect to account for while constructing new amenities on a property” (Building Safety, 2020). When considering the safety aspect of an outdoor kitchen, the majority of the concern was centered around having an open flame (Grilling Safety, 2020). It is crucial to ensure all appliances with a flame remain a safe distance from any flammable material. This distance could range from approximately 3 feet to 5 feet (Grilling Safety, 2020). In the event a flame is lit beneath a roof, the roof also requires an exhaust hood which can add to the cost significantly at upwards of \$650.00 (Zline, 2020). The use of a sink is another major concern while constructing an outdoor kitchen. If the sink is simply used for washing off fruits and vegetables, the water waste should pose no threat to its surrounding environment when drained. However, if the sink is used to wash dishes with raw animal contaminants, a risk is then posed to whatever wildlife and plants come in contact with this waste water. In this case, the sink needs to be connected to a drain-waste-vent system (pictured on the right) to correct this problem (Mathewson, 2018). Following these building safety precautions is a way to further ensure that people who use the kitchen, as well as the surrounding wildlife and plants, are safe within reason.

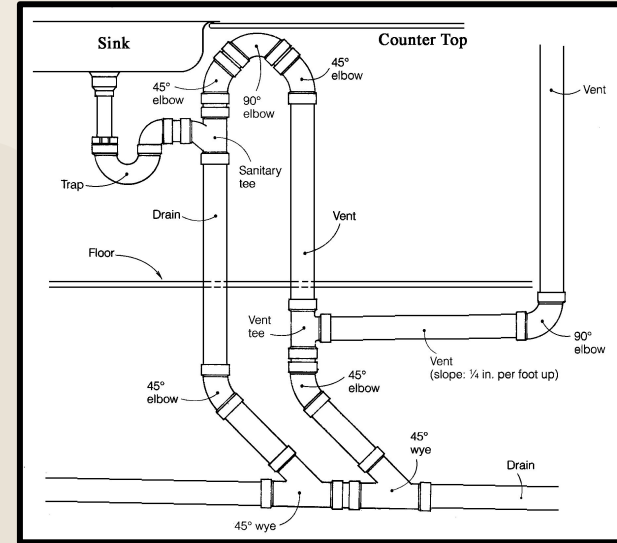

Drain-Waste-Vent System

# Nature Based Learning



TBT is a facility and program that promotes outdoor education of children during their developmental stages and into early childhood years. In the article Benefits of Nature Contact for Children (2015), Louise Chawla supports the importance of outdoor enrichment for children and young adults. Chawla outlines both physical and mental benefits attributed to nature-based learning.

Chawla outlined many key points, the first being how outdoor exposure and interaction helps to lower rates of allergies and asthma as well as increasing motor coordination and balance. These two main points show how through outdoor exposure children can become more resistant to certain conditions. Additionally, these points also show that through outdoor activities, children will gain an increased sense of coordination. Outdoor interactions not only help from a health and physical standpoint, but mentally as well (Chawla, L, 2015).

Chawla describes how outdoor interactions for children increase mental health and creativity. Children are more apt to be more creative and come up with new games while working with others and creating bonds. Being outside also increases the attention span of a young child because they become more aware of their surroundings. Outdoor activities also decrease levels of stress and depression, while increasing energy levels. There are many benefits to outdoor learning and exposure that TBT has recognized and are now implementing into their work with children (Chawla, L, 2015).



Chicken Coop at TBT



Story Time at TBT



# 3. Methodology

This section provides a detailed description of all methods that were applied to the design and construction of the outdoor kitchen to be built at TBT during the spring of 2020 in regards to the new COVID-19 restrictions. The information in this section was used to determine the final building design, methods, and considerations.

The construction of the kitchen will now be scheduled after the person in contact ban is lifted.

## **In this Section:**

- Assessing Outdoor Kitchen Appliances
- Supplying and Managing Water and Electricity
- The Outdoor Kitchen and Natural Environment
- Weather Resistant Materials and Methods
- Reduction of Waste
- Immersive Educational Environment
- Project Timeline



# Assessing Outdoor Kitchen Appliances

The first objective of the outdoor kitchen project was to research examples of best practices for installing and using outdoor kitchen appliances while also including educational aspects to the design. One way our team fulfilled this objective was through interviews conducted over zoom. We interviewed Lisa Burris (Turn Back Time owner), Connor Stedman (agricultural worker), and Mario Alagna (architect and developer). The purpose of these interviews was to gain a better understanding of different appliances that are common commodities in outdoor kitchens, and to weigh the pros and cons of each.

We then asked Lisa to perform a site assessment in and around the proposed area where the kitchen will be built. The purpose of the site assessment was to determine how much water and electricity can be supplied to the area, and how much total area is available for the kitchen. Also, it was important to note other types of resources available within a short walking distance, such as wood for fueling the pizza oven and picnic tables to serve as an eating area.



Kitchen Build Area



TBT Unused Pavers

Through the site assessment, we also, asked Lisa Burris to provide measurements of donated unused pavers, which can be used towards the creation of the kitchen patio. By taking the unused materials at TBT into consideration for creating kitchen appliances, the overall cost of the kitchen will decrease. This saved money can go towards future kitchen additions or can be used towards future projects at the farm.

Lastly, archival research was used to determine the costs of different appliances as well as their benefits and limitations, such as cost. Due to TBT's financial challenges resulting from the COVID-19 pandemic, Burris asked that we keep the overall budget as low as possible in order to ensure that all parts could be bought within the farm's financial constraints and ultimately built. The analysis of other benefits and limitations of each appliance we critical for us to ensure that we understood the needs and wants of TBT's various stakeholders.

# Supplying and Managing Water

The second objective was to design an efficient method to supply the outdoor kitchen with water. To fulfill this objective, under remote circumstance, we had Lisa Burris conduct a site assessment to understand how far away our nearest water source would be. We also conducted an interview with Lisa Burris to gather more information on how she envisions of the kitchen. Furthermore, we performed archival research to determine the best material and methods to supply water to the kitchen. However, after further discussions with Lisa Burris, she informed us that all plumbing would be completed by a licensed plumber to cover her legally in any plumbing issues that could happen. This is important as Turn Back Time is an education facility. If plumbing is done incorrectly and water becomes contaminated because of it, children using the sink could get sick, causing for lawsuits. By having Lisa Burris address the plumbing for the kitchen, this situation will not arise. Thus, further research by our team on managing water and electricity was not completed and instead to be completed by a licensed plumber per Lisa's request. Therefore, this objective will not be addressed any further.

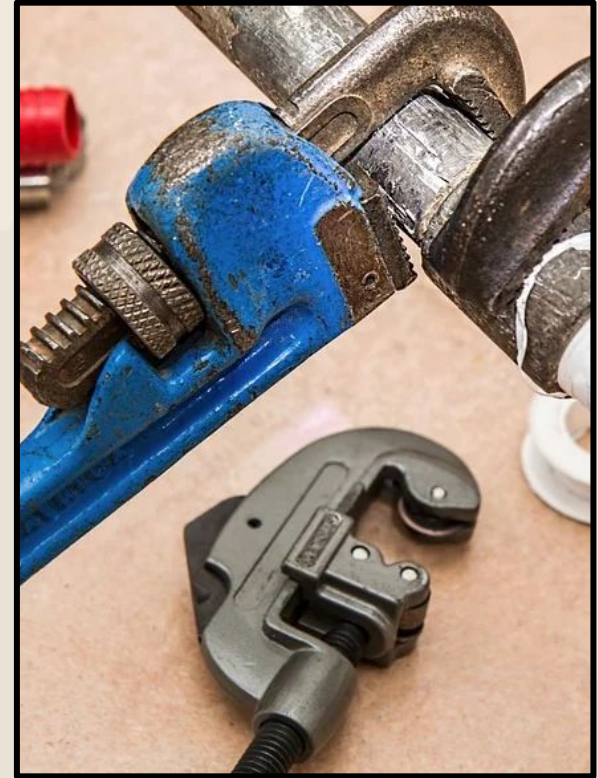

Plumbing Tools

# The Outdoor Kitchen and Natural Environment



To successfully complete the third objective of keeping the kitchen protected from the environment, it was necessary to research weather-resistant materials and wildlife prevention in New England. We searched for both successful methods and failures to access the best weather resistant materials and what materials to avoid. Specific to the town of Paxton, there is an abundance of information on which pests are most prevalent at different times throughout the year on the town's website as well as The Division of Fisheries and Wildlife 2020 (Welcome to the Town of Paxton, 2020). In addition to these resources of information, researching the cost of materials was important especially when looking into weather-resistant materials as they can tend to be more expensive. This was completed by using store prices such as Home Depot or Lowe's. The data found in the archival research was used to best design a long-lasting outdoor kitchen for many years to come.



Weatherproof Lumber



Smoke from Pizza Oven

Our team also looked at the ways in which the kitchen might negatively impact the natural environment, such as air pollution and carbon emissions from a rocket stove and pizza oven. Through archival research at the WPI Library and databases such as, CLEAN - Soil, Air, Water and Waste Management and Research, our team better grasped the concept of carbon footprints. Our team then considered where expelled smoke from the rocket stove and pizza oven will accumulate. We had to take steps in planning where the kitchen will be built to prevent possible fire hazards and remove undesired smoke. This is both an environmental and safety concern.

To protect the proposed kitchen from the natural elements, we also research possible kitchen coverings. We did so through articles and website, as well as through an interview with an engineer and pergola owner, Edward Ledger. With a pergola as one of the possible coverings, we concluded that Ed's experience here, as well as his expertise as an engineer would provide us with critical information regarding all possible types of kitchen coverings.

Finally, to fill out our understanding of how weather may impact the kitchen, a site assessment was performed to evaluate how water moves and pools in the proposed kitchen location. The assessment was performed remotely with the collaboration and support of Lisa Burris, as we could not visit TBT due to COVID-19 restrictions. While surveying the land, we asked Burris to look for aspects, such as if the outdoor kitchen is being built in a low spot, at the top of a hill, or on an incline, to determine if the water is going to pool at our structure or if a drain is needed to prevent this. Water pooling near our structure is dangerous, as it can cause rot or if the structure is on an incline and water is running by, it could cause erosion. This information was then received by our team through communication with and images from Lisa.



Example of a Pergola Style Covering

# Weather Resistant Materials and Methods

The fourth objective was to collect weather resistant materials and research weather resistant methods to maintain the life of these materials. To fulfill this objective, our team first conducted two interviews: one with pergola owner and engineer Ed Ledger, and one with architect Mario Alagna. The goal from the interview from Ed was to determine which types of wood were used for the pergola build. A discussion with Ed would help us better understand how he selected the materials he did, how these materials have held up, and an estimated price on how much was spent on these materials. The goal from the interview with Mario was to use his expertise in the area of architecture, as well as his vast experience with different types of wood and preservation methods, to gain further knowledge in these areas.

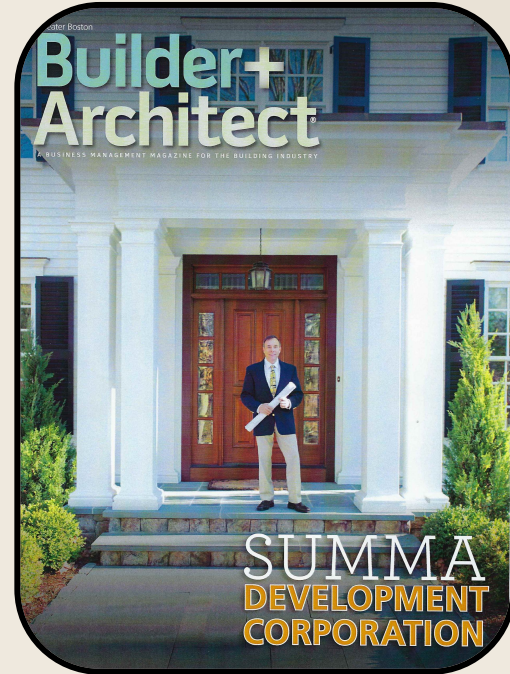

Mario Alagna, Architect



Applying Polyurethane

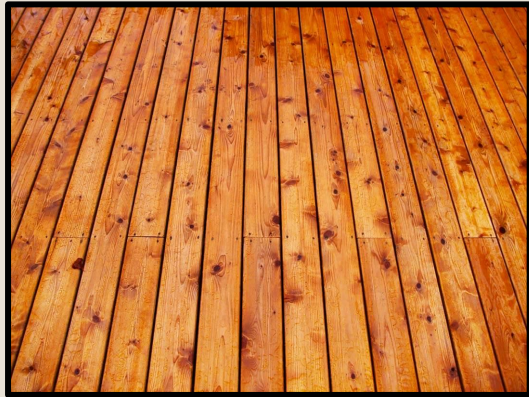

Finished Wood with Stain

To further meet this objective, we conducted archival research into different types of wood and preservation methods. The main purpose of this research was to gain further knowledge as to what types of wood and preservation techniques are common. Also, in contrast to information we could receive from the interviews, online research through Home Depot and Lowe's could provide us with exact prices and more detailed explanations of different preservation techniques. This information helped us to make more informed judgements when putting decision matrices together, which would ultimately decide which types of wood and preservation methods would be used toward the build.



Various Wood Stains

# Waste Management

Our team's fifth objective was to increase our knowledge of waste management. As the primary function of the kitchen is to provide an outdoor area where college students and kids can prepare and cook food, it was important that we took into consideration how to reduce any resulting food waste. As a result of the kitchen being used at TBT for many years to come, the outdoor kitchen will produce a significant amount of food waste. According to the Washington Post, "Cutting down on food waste could have nearly the same impact on reducing emissions over the next three decades as onshore wind turbines" (Frischmann, 2018). To reduce the environmental impact of food waste from the outdoor kitchen, the waste could be composted. Composting acts as a way for a significant amount of uneaten food and peels to be turned into a form of fertilizer for plants to grow. According to the University of Georgia, "If it can be eaten or grown in a field or garden, it can be composted" (Risse, 2017). Implementing a composting system at TBT can act as an environmentally friendly solution to reduce the kitchen's food waste, as well as a teaching point for students at TBT's programs to see their food waste being reused in the garden.

- In order to fulfill this objective, archival research was necessary to see what common methods are used for reducing wasted food in an outdoor kitchen. We hoped that by better understanding the different methods and their associated costs, we could make a better judgement as to which waste management methods are practical for TBT.

Our team also performed an interview with agricultural planner Connor Stedman in hopes of gaining more insight into how to manage food waste through composting, in addition to the potential of using the composting system to enhance educational opportunities. We believed his years of experience in agriculture would help us further understand how we could fulfill this objective.



There are ways to reuse the food waste in a garden as a nutrient for the plants to grow.



# Immersive Educational Environment

Our team's final objective was to create an immersive educational environment for children to use during their time at TBT Farm's outdoor kitchen. To fulfill this objective, our team performed archival research in the field of kitchen education. The goal of this research was to better understand different subjects that can be taught in a kitchen environment, and a variety of methods to teach each of these subjects. For example, in what ways can math and science be taught through preparing and cooking meals? It is important to find multiple ways to accomplish this because children learn differently, and what is best for one child may be a different medium than what is best for another child. There is also a wide range of children who attend TBT's programs, so it is important to have a variety in lesson plans that match this age diversity. This archival research helped our team better understand all of the potential teaching points our kitchen can provide, as well as a method for providing these lesson plans to teaching staff in a living document.



Children Eating “Buffet Style” at TBT



Child Making Mud Pies at TBT

To further fulfill this objective, we performed an interview with TBT Director Lisa Burris. The goal of this interview was to determine what types of educational subjects in a kitchen environment would interest her the most. For example, would she like the focus of the kitchen's educational aspect to be based around math and science, reading and writing, or another subject? This information would help our team determine which subject to create an activity based off of. Also, through the interview, we hoped to determine which age groups would be appropriate to target through the interactive activity. This would help us focus our research into a more specific age group instead of looking for broad teaching points that cover larger age ranges.

# 4. Results and Findings

In this section, our group will elaborate on our findings through research and results that we have gained through interviews, surveys, archival research, and site assessments. We will also elaborate on what remains to be done in the future in order to fulfill our objectives.

## **In this Section:**

### **Kitchen Appliance Findings**

Rocket Stove

Pizza Oven

Kitchen Covering

### **Improving the Kitchen's Longevity**

Material Decisions (Wood)

Wood Preservation Techniques

Pest Resistant Design

Winter Storage

### **Waste Management**

Composting Bin

### **Immersive Educational Environment**

Educational PowerPoint

# Kitchen Appliance Findings

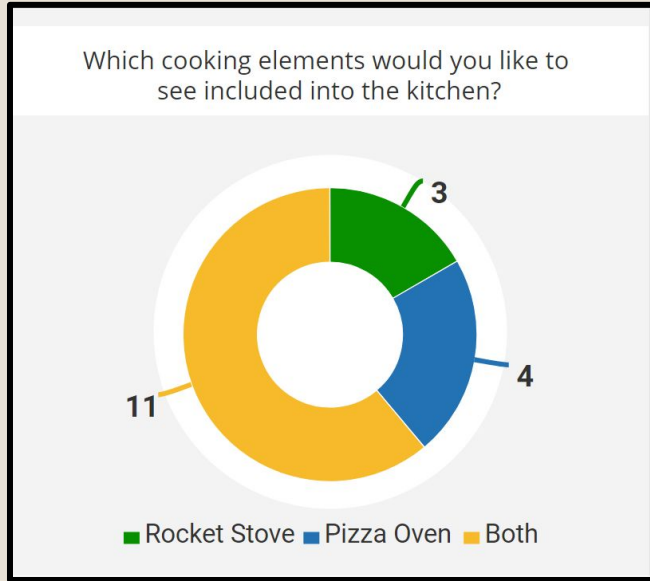

18

Total Respondents

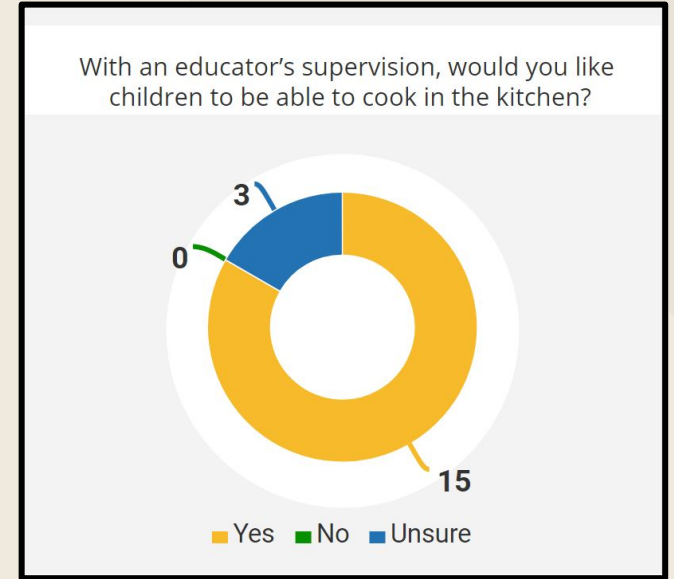

Through a survey sent out to TBT stakeholders, we were able to better understand what various groups desired in an outdoor kitchen at TBT. The first set of unique appliances that were analyzed were a rocket stove and a pizza oven. 11 out of 18 respondents wanted to see both appliances in the kitchen area. Another interesting finding from the surveys was that 15 out of 18 respondents would like children to be able to cook in the kitchen, with the support of an adult. This finding further supported and guided our plan to add educational features to the kitchen, in order to create an immersive learning environment for the children at TBT.

## Rocket Stove

Our team first learned what a rocket stove was during one of our first meetings with Professor Stoddard, Professor Rosbach, and Lisa Burris. This was an unfamiliar cooking tool that our team had not heard of before, but were excited to learn more about. We learned that a rocket stove acts as a hot surface to cook food and boil water by burning wood. Rocket stoves are typically used at campsites and other outdoor settings that need a more durable appliance to cook with. A rocket stove, however, is not a commonly used tool in comparison to an open campfire. Although, using a rocket stove rather than a campfire would result in a more efficient and sustainable way to transfer heat (The Ashden Awards for Sustainable Energy, 2006). Unlike a campfire, a rocket stove utilizes a chimney. By using a chimney, combustion efficiency can be increased by creating a strong draft wind through the chamber, pushing heat to a desired surface (Rocket Stove, 2006).



Example Rocket Stove

In one example, “A primary school in Mozambique switched from using a fire pit with an open flame to utilizing a rocket stove”. As a result, it “has more than halved its expenditure on fuel wood and now has an additional US \$1,200 to spend on students' educational needs... and reduced its expenditure on fuel wood from around US \$400 to US \$100 per year” (The Ashden Awards for Sustainable Energy, 2006). In addition, a rocket stove’s fuel efficient design reduces smoke production because of a small inlet and outlet, reducing air pollution and associated environmental and public health harms associated with wood stoves (The Ashden Awards for Sustainable Energy, 2006).

When considering the benefits and limitations of a rocket stove for the outdoor kitchen at TBT, one consideration was cost. Burris explained that wood is readily available at TBT. As such, the only cost of the stove is the stove itself, not the fuel. This benefit, as well as the interest from stakeholders, and the educational potential discussed earlier, made the rocket stove appealing. However, before making the final decision on utilizing a rocket stove, our team compared the qualities of a rocket stove to other methods of cooking, including a grill and a campfire.



<b>Cooking Method</b>
<b>Fuel Supply</b>
<b>Emissions</b>
<b>Aesthetics</b>
<b>Price</b>

Rocket Stove
Wood
Wood, Rocket Stove: 0.0099208 lb/hr CO <sub>2</sub>
Not commonly seen and will bring uniqueness to the outdoor kitchen. Not a wide variety of appearances available for purchase, but offers a rustic outdoor look. Easy to clean and maintain.
\$100 - \$500

Grill
Propane, Charcoal, Natural Gas
Propane, Natural Gas : 5.6 lb/hr CO <sub>2</sub> Charcoal : 11 lb/hr CO <sub>2</sub>
Commonly desired outdoor cooking appliance. Can come in a wide variety of appearances to suit any need. Easy to clean and maintain.
\$100 - \$3,000

Campfires and Fire Pits
Wood
Wood, Open Flame: 0.02 lb/hr CO <sub>2</sub>
Commonly used in outdoor social settings like campsites. Can be built in any size to meet the needs of user. Not eye catching and constant maintenance required to remove soot and ashes.
\$300 - \$1,400

After comparing these three options for cooking methods, our team came to two main conclusions. The first was that we believed a grill would be a great option for the outdoor kitchen due to how it is commonly used and is often a center piece in many outdoor kitchens. In an interview with Conor Stedman he explained to our team that, “A grill is the most commonly used outdoor cooking method and it offers convenience and user practicality.” (C. Stedman, personal communication, April 14, 2020). However, a grill is not as sustainable as an option compared to a rocket stove or a fire pit because a grill uses propane, charcoal, or natural gas. These fossil fuels inflict a much harsher impact on our atmosphere because of its increased emission of greenhouse gases, mainly CO<sub>2</sub>. As outlined on the previous page, depending on the desired fuel type, the average grill will emit 5.6 lb/hr CO<sub>2</sub> for propane or natural gas, and 11 lb/hr CO<sub>2</sub> for charcoal (EPA, 2012). A rocket stove and open flame, however, only emit 0.0099208 lb/hr CO<sub>2</sub> and 0.02 lb/hr CO<sub>2</sub> respectively (EPA, 2018). After finding these data points our team could effectively say that a grill is the least sustainable option. Our team still would like to utilize a grill to create a good user experience, but we would like to recommend the most environmentally sustainable option to be purchased by TBT.

The second conclusion was based on previously discussed research comparing the efficiency of a rocket stove and campfires. After learning how a rocket stove is both more sustainable environmentally and economically, our team made the decision to recommend the usage of a rocket stove for TBT’s outdoor kitchen.



CO<sub>2</sub> Emissions

We shared our survey results, interview data, and archival research with Burris regarding the rocket stove and other possible outdoor cooking methods. Burris concluded that she would like to include both a rocket stove and a grill in the outdoor kitchen. Burris had an unopened grill she had purchased for an event and never used. She asked us to incorporate this grill into the design of the kitchen. As for the rocket stove, she encouraged our team to find a rocket stove that may be donated or discounted. Lisa requested that our team do this because an aesthetically pleasing rocket stove that would be able to support the needs of an outdoor kitchen can cost on average around \$300-\$500 (NorthlineExpress, 2020). Rocket stoves can be purchased for a lower price point of around \$20-\$100. However, these less expensive rocket stoves possess a much smaller available cooking surface area. Also, they do not possess a sturdy design, as they are constructed to be light weight and mobile (NorthlineExpress, 2020). Our team recommended a more expensive rocket stove to Lisa to ensure that the cooking demands of the outdoor kitchen can be met, while still remaining highly aesthetic.

One team member from our group, through networking, was able to receive a donated rocket stove from Northline Express that would be built into the outdoor kitchen countertop. The dimensions of this rocket stove are 20" W x 30" H x 22" D, which is 6" shorter than our countertop design, which is 36" high. In order to provide a uniform look and function for the outdoor kitchen, our team designed a 6" platform to be used as a mount for the rocket stove. This allows for the stove top to be flush with the countertop, as well as secure the rocket stove to a level surface. This creates a unique outdoor kitchen while creating a good overall aesthetic, keeping costs low, and lowers our safety concerns about the rocket stove potentially tipping over during use. The rocket stove will also be 6" away from the nearest edge of the countertop, complying with building and safety regulations. The team then informed Lisa of the donations that we had received and then planned to have them brought to TBT.



Donated Grill



Donated Rocket Stove



## Pizza Oven

Similar to the rocket stove, a brick pizza oven was proposed to our group during a preliminary meeting with Professor Stoddard, Professor Rosbach, and Lisa Burris. This appliance was proposed because of how it would add an aesthetically pleasing and unique cooking opportunity for users of the TBT kitchen. Lisa was interested in having a brick pizza oven to be used for retreats, the Farm Stay Project Center, and events that might be hosted at TBT. Lisa did not provide us with specifications for how large of a pizza oven she desired, nor did she give us a definitive budget. She wanted us to start by exploring various options, sizes, and costs to better inform her decision making. Based on her desired uses for the pizza oven, we began by researching pizza ovens we could design and TBT could build that would be large enough to bake enough pizzas to supply a large family or small restaurant (Forno Bravo, 2020).



Pizza Cooking in a Brick Oven



Brick Pizza Oven



Igloo Dome



Barrel Oven

Before our team could provide Lisa with an initial budget, we had to take some design considerations into account to then accurately determine the cost. The first major design consideration was the type of pizza oven that could be built. There are two types of pizza ovens that our team could choose from, either an igloo dome or a barrel oven. Both are traditional brick pizza ovens, but they offer different things. An igloo pizza oven requires less wood for an initial start up, and it offers a faster cooking time because of a faster start up period with more uniformed temperature throughout the oven (Abrams, J. L., Goeden, M. C., Kean, A. J., & Hill, C. D., 2017). In contrast, a barrel pizza oven requires more wood for an initial start up, but it provides uniform temperature for a longer period of time. For this reason, barrel ovens are typically used to cook bread and bake pottery, which require long cook periods. However, a pizza being cooked in a wood fire oven only needs 90 seconds to 5 minutes to fully cook (Abrams, J. L., Goeden, M. C., Kean, A. J., & Hill, C. D., 2017). As such, we determined an igloo pizza oven would be a better option for TBT, as it would require less wood to start up and can cook pizzas faster and more efficiently.

We determined that we should propose building an igloo brick pizza oven that possessed a 42" inner diameter, a 30" chimney, and was mounted onto 4.5' x 4' countertop. A pizza oven of this size is large enough to meet the needs already mentioned and would also fit perfectly into our proposed countertop to provide a good aesthetic. This pizza oven would need to be constructed out of fire brick, insulating material, and an outer shell of clay. An estimate for this pizza oven ranged from \$1200 - \$1600 when searching for prices of materials online on Home Depot and Lowe's websites.

After putting together a budget for the total cost of our outdoor kitchen, we then presented it for approval to our advisors and Lisa Burris. Due to the impacts of COVID-19 and uncertainty for what the future held, Lisa was hesitant to put this much money into one element of the kitchen. Our team was not surprised at her initial reaction, and Professor Stoddard helped with suggesting a smaller, more portable pizza oven. We then found multiple alternative options which fit the suggestion.

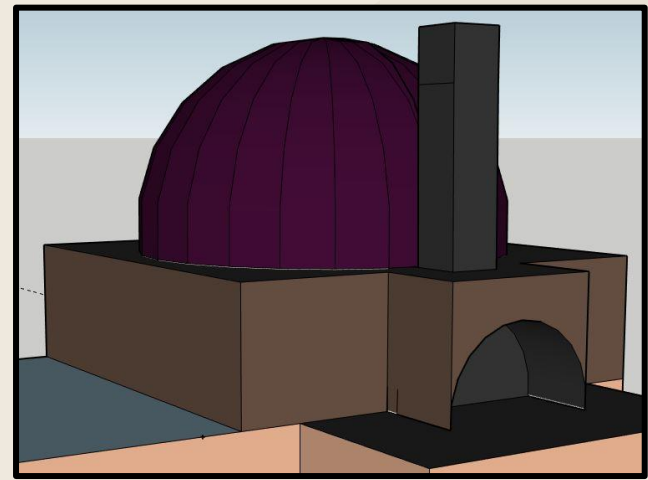

Initial Mockup Design

**Fire Brick**  
**\$1,330**

Approximately 250  
required for \$5.32 each

**Clay**  
**\$180**

Approximately 6 bags  
required for \$30 each

**Insulation**  
**\$79**

Approximately 50 Sq feet  
required for \$1.58 per Sq foot

By conducting remote research, our team was able to find three potential options for Lisa to choose from to fulfill the need of having a pizza oven. All three of these options are smaller portable pizza ovens that can be moved to a different location to be stored in when not in use or during inclement weather.



Pro Lil Luigi Portable Outdoor  
Wood-Fired Pizza Oven



Mont Alpi Portable Propane  
Gas Outdoor Pizza Oven



Ooni Pro Portable Outdoor  
Wood-Fired Pizza Oven

Dimensions	Type of Fuel	Pizza Size	Cost
16" x 32.7" x 33"	Wood	10"	\$350
15" x 18" x 19"	Propane or Wood	12"	\$275
19.29" x 29.13" x 31.1"	Wood	16"	\$599

Professor Stoddard also recommended that our team investigate if a terracotta pizza oven would be an option. Professor Stoddard found a Blue Fish Terracotta Pizza Oven that could be purchased online from Cost Plus World Market for \$89.99. This provided an extremely pleasing upfront cost for the pizza oven amenity in our kitchen. However, without a chimney to move smoke out of the kitchen, our team would need to fasten an outlet hose onto a chimney to redirect smoke outside of the kitchen to prevent possible fire hazards. This pizza oven does not possess this capability without ruining the aesthetic of the pizza oven. After giving this option consideration due to the low price and nice aesthetic, our group determined that we could move forward with this option due to the issue of smoke management.



Blue Fish Terracotta Pizza Oven

After our team completed thorough research and weighed all of the options, we shared our findings with Lisa. It was then determined that our team would move forward with the “Ooni Pro Portable Outdoor Wood-Fired Pizza Oven” as the pizza oven we would recommend for TBT. This option could be provided at almost half the cost in comparison to the original idea of a brick pizza oven. This pizza oven, compared to the other small portable options, offered the largest surface area to bake a pizza, while keeping a good aesthetic and factoring in safety considerations.



Suggested Pizza Oven

Although we suggested that Lisa Burris purchase the Ooni pizza oven, she ended up receiving the “Alfredo Terracotta Outdoor Pizza Oven” at a discounted price of only \$400.00. The reasons Ms. Burris decided on this pizza oven are the 35” diameter area for larger pizzas, the discounted price she could receive from the seller, and the outdoor aesthetic that she believed this oven provides. Lastly, Lisa Burris discussed with our team that due to the design of this pizza oven, she believes that if the pizza oven is positioned in a corner of the outdoor kitchen design, then the ventilation will not need to be considered due to natural cross-winds. After discussion with her husband and the oven’s previous owner, Ms. Burris has decided to ignore ventilation unless any potential issues arise over time.



Purchased Pizza Oven

## Kitchen Covering

When brainstorming the potential necessities and desires of the users of the outdoor kitchen, the idea was brought up amongst our team to provide an affordable option for covering the kitchen area. We discussed the need of a cover to protect the kitchen's appliances from inclement weather, and to protect against falling leaves and sticks, which would require regular maintenance and could damage the proposed granite countertops. We also considered that a cover could also provide a nice aesthetic, if properly researched and designed. Based on some initial research, our team discussed three options with our advisors and Lisa, including an awning, a pavilion, and a pergola.



Example of Outdoor Kitchen Covering



**Awning**



**Pavilion**



**Pergola**

**Support Structure**

Needs Support Structure

**Aesthetics**

Any custom size, color, or pattern; 180-270 degree open view

**Protection**

Blocks sunlight and light rain

**Cost**

\$400-\$3,000

Free Standing

Medium to Large Size; Tall Angled Roof; 360 degree open view

Sunlight, Rain, Snow

\$2,000-\$15,000+

Free Standing

Small to Medium Size; Medium to Tall Flat Roof; 360 degree open view

If standard model, none

\$500-\$3000



After some initial research, pergola owner Edward Ledger came to mind as someone who would have some insightful information to provide to us for this topic. Edward is a family friend of Nick who when hearing of our team's project became very interested in wanting to assist in any way he could. Edward is a self taught carpenter who also works as a mechanical engineer at BAE Systems. When asked what inspired him to design and build a pergola in the first place, Edward responded, "Form and function. We have always liked the look of pergolas and it gave us a structure that could be used for protection from the elements and yet still allow sunlight to shine through. Also, in comparison to other outdoor covers, this option was one of the cheapest available" (E. Ledger, personal communication, April 10, 2020). This insight reassured our team that a pergola is aesthetically pleasing, practical, and comparatively cheap to a pavilion. When asked what type of covering he had added on top of the structure, Edward stated that "Corrugated plastic panels were used" (E. Ledger, personal communication, April 10, 2020).

Although Edward did not send our team a picture of the pergola he designed, he sent us a picture from the internet that inspired his design. This image was then used as a baseline for our pergola designs through Google SketchUp and Solidworks. However, specific dimensions and wood sizes had to be adjusted to meet the changing requirement of Lisa Burris. Lisa specified that the covered area of the kitchen needed to be only 14 feet by 14 feet due to the amount of leveled land area. Our group will adjust by changing the designs to represent a 14'x14' kitchen area and a similar size pergola cover.



Baseline Pergola Design



Edward Ledger

## CAD File Designs from our Proposed Pergola Design

After all of this initial research and design work, we now have multiple designs of the pergola as well as a rough estimate of the overall cost of approximately \$511.00 after researching wood cost on Home Depot's website. Further insight about our pergola design will be discussed in a later section titled, "Bringing it all Together" in the "Deliverables" section.

### Pergola Estimated Price Breakdown

Quantity of Lumber	Dimensions	Price
4	2" x 10" x 16'	\$24
10	2" x 8" x 16'	\$15.50
8	2" x 4" x 12'	\$10
4	7.25" x 7.25" x 12'	\$45
Total Cost		\$511

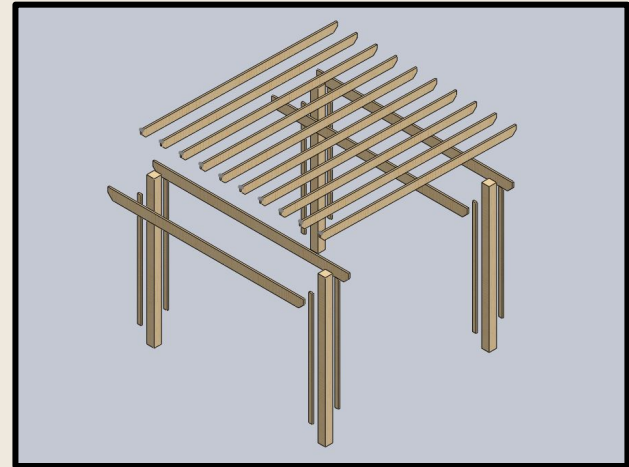
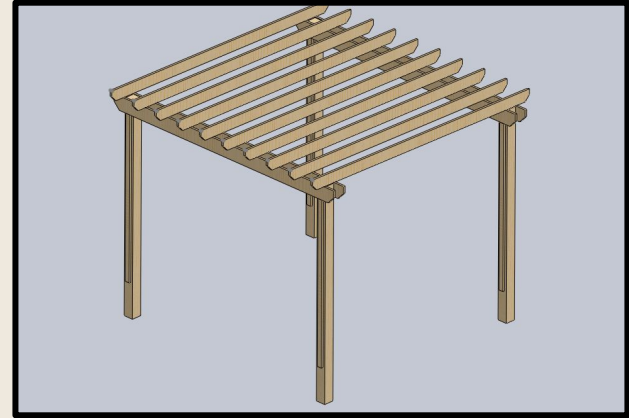

# Improving the Kitchen's Longevity

## Material Decisions (Wood)

When brainstorming ways to improve the longevity of an outdoor kitchen, the type of material used in the build is the most important aspect of meeting this objective. Due to the fact that the pergola and overall frame of the kitchen will be made out of wood, we needed to determine what type of wood is the most cost effective and durable. The wood for the pergola and the wood for the frame of the cabinets serve different purposes, so research and interview questions were formed for each separate purpose.

After some initial research on pergola designs and materials, we interviewed pergola owner Ed Ledger regarding what type of wood he used for his design and his reasoning behind it. When asked to list all types of wood that were used in the pergola, Ed replied with, "All of the wood is pressure treated lumber. All of this wood was purchased at Home Depot. There has yet to be any maintenance necessary with the entire pergola, and the lumber looks as good as the day it was made five years ago." (E. Ledger, personal communication, April 10, 2020). This analysis from Ed matched our prior beliefs and research performed on common pergola designs. Many pergolas which could be purchased online through kits or various companies used pressure treated lumber, due to its low cost, longevity, and aesthetics. We have moved forward with a budget and design that uses pressure treated lumber for all parts of the pergola.



When considering our options for the interior frame of the kitchen, we researched four types of wood that we believed would be the most appropriate for our application: marine, cedar, pressure treated, and plastic lumber. Each of these types of wood were recommended for research by architect Mario Alagna, as they are “common types of wood found in outdoor kitchens” (M. Alagna, personal communication, April 15, 2020). The multiplier used in the decision matrix consists of cost analysis, durability, aesthetics, and means of transportation possessing values of 4, 3, 2, and 1 respectively. These values were determined on what was most important to the sponsor and their needs. The highest overall value was then used to determine which types of wood were the best suited.

Types of Wood	Cost	Durability	Aesthetics	Means of Transportation	
<b>Multiplier</b>	4	3	2	1	<b>Total Score</b>
Cedar Lumber	4	2	2	2	<b>28</b>
Marine Lumber	1	3	1	2	17
Plastic Lumber	2	3	3	2	25
Polyurethane Pressure Treated Lumber	3	3	3	1	<b>28</b>

Wood Building Material Decision Matrix

**Cedar Lumber**  
**\$4.63 per foot**  
 15-20 years of durability

**Marine Lumber**  
**\$9.68 per foot**  
 15-20 years of durability

**Plastic Lumber**  
**\$7.82 per foot**  
 40-50 years of durability

**Polyurethane Pressure Treated**  
**\$8.68 per foot**  
 45-55 years of durability

After performing a cost-benefit matrix as a team, we determined that pressure treated and cedar wood would be the best options for the framing of the kitchen. This finding was supported by our interview with architect Mario Alagna. When asked about what types of wood should be used for the interior frame, he advised our group to use cedar or pressure treated wood for only the frame of the kitchen. We were told that cedar is too soft of a wood to use for the entirety for the kitchen – beyond the frame. Our kitchen would likely not hold up to the New England weather if we ended up choosing this option (M. Alagna, personal communication, April 15, 2020). Because pressure treated wood being significantly more durable, we will be using pressure treated wood for the frame.



Mario Alagna



# Wood Preservation Techniques

In order to keep costs low and increase the lifespan of the kitchen, the team researched different preservation techniques that we could use to treat the wood. By potentially using a preservation technique, our team might end up being able to purchase a more cost effective type of lumber, which would drastically lower the overall budget. This was a main goal of our group, as we wanted to provide Lisa Burris and TBT with an affordable option during the COVID-19 pandemic. In this section, our group will discuss wood stain, polyurethane, wood sealer, and Shou Sugi Ban. All preservation techniques are compared in a decision matrix on page 67.

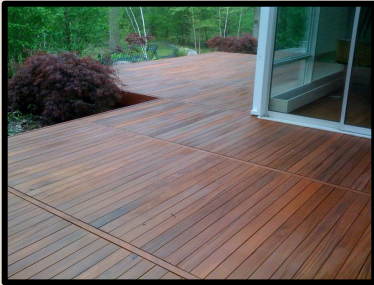

Wood Stain



Polyurethane



Wood Sealer



Shou Sugi Ban

Before conducting any research, our group was familiar with two types of wood preservation techniques, the first being wood stain. This option is a commonly used practice to increase the life of wood anywhere from 3-5 years before more applications are required (Cayton, R., Murray, P., Nelson, D., & Ostrowski, R., 2010). Wood stain also offers the uniqueness of being able to choose from a large amount of colors and by applying more coats to increase the darkness of the color. It is also easy to apply to a wood surface, as you may use a brush to paint the stain onto the wood. Exterior wood stain is offered in quarts ranging in price from \$11-\$15 at Lowe's and Home Depot. A much larger 5 gallon bucket of stain can also be purchased from the same retailers for around \$160, but this option limits the color options available to TBT (Home Depot, 2020).



Example of Wood Stain



Polyurethane

The second option that the group knew of, was using polyurethane as a preservation technique. Like wood stain, polyurethane is also a common practice that is used to preserve various types of lumber. Polyurethane is distinct from stain, however, because it is a lacquer material that provides a protective sealant coating onto applied materials such as wood or metal. It offers more durable long-lasting protection that can also be applied with a paint brush. It is recommended to apply additional coats of polyurethane every 10 to 20 years, depending on the integrity of the coat and the weather conditions it is under (Cui, S., Luo, X., & Li, Y., 2017). This option is more long lasting and economically sustainable in comparison, but it still has its downsides. Lisa requested that we create an aesthetically pleasing outdoor kitchen, and polyurethane would add no aesthetic benefit because it is only a clear coat. It can, however, be applied to surfaces that have already been stained or painted. This would increase costs however because both preservers would need to be purchased. Polyurethane can be purchased at Home Depot and Lowe's for a price of \$11-\$15 per quart (Home Depot, 2020).



A third option that was that we researched was a wood sealer, another preservation technique. Based on our research, it was determined that wood sealer had almost identical properties as polyurethane. The main difference between the two techniques was the price and application required. The price for this method was less expensive for the material itself, only being on average \$16/gallon, but application tools would need to be purchased (Home Depot, 2020). Wood sealer requires the use of a sprayer and holding reservoir. This would increase upfront cost and would be an unfamiliar method of application for our team. Wood sealer is also a clear coat, so paint or stain would also still be required in order to provide a good aesthetic.



Application Process of Wood Sealer

After consulting with our advisors about the techniques that we researched, Professor Rosbach recommended that we also look into an old Japanese preservation technique called, Shou Sugi Ban. This technique is both an economical and environmentally sustainable alternative that has been used for hundreds of years. It requires the user to char the exterior surface of the lumber being used with a flame of some sort. It creates a unique look to every piece of wood, and no two look alike. By charring the surface of the wood, any pests are repelled from degrading the integrity of the wood and it also waterproofs the wood. Shou Sugi Ban provides a unique preservation technique that would preserve wood for 80-100 years, making it the most durable option (Cumming, A., 2011).

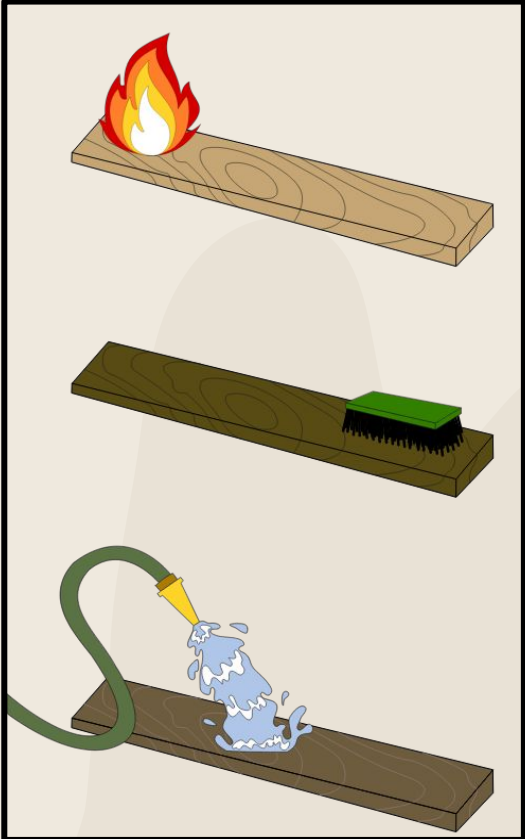

Required Steps of Shou Sugi Ban

This method's application process is complex, however, and would require purchasing a large industrial blow torch. In order to properly preserve the wood using this method, the user would need to become accustomed to using a blow torch, and the method for charring, not burning the wood. If the flame is too powerful then it will ignite the wood, and would result in a loss of material. This technique is a skill that is needed to be practiced, and if done incorrectly, it would not preserve the wood properly. This technique is also time consuming. A well experienced craftsman, with the know-how of Shou Sugi Ban, would be able to treat the amount of lumber required for our outdoor kitchen in about one day. However, an inexperienced individual may require two to three days to become confident enough using an industrial blowtorch, to then properly execute this method, and create a uniform char on all the necessary lumber for building. (Cumming, A., 2011) This technique would also only be able to be utilized if cedar is the chosen building material (Cumming, A., 2011).

The multiplier used consists of cost, durability, aesthetics, and means of application possessing values of 4, 3, 2, and 1 respectively. These values were determined on what was most important to the sponsor and their needs. The highest overall value was then used to determine which technique was the best suited.

Preservation Techniques	Cost	Durability	Aesthetics	Means of Application	
<b>Multiplier</b>	4	3	2	1	<b>Total Score</b>
Polyurethane	3	3	2	3	28
Shou Sugi Ban	1	4	3	1	23
Wood Stain	4	2	4	4	<b>34</b>
Wood Sealer	2	3	2	2	23

Preservation Technique Decision Matrix

## Polyurethane

**\$70 (4qts, Application Tools)**

5-10 years of durability

## Shou Sugi Ban

**\$230 (Blowtorch, Fuel)**

80-100 years of durability

## Wood Stain

**\$50 (4qts, Application Tools)**

1-2 years of durability

## Wood Sealer

**\$125 (4qts, Application Tools)**

3-5 years of durability

After researching multiple techniques, the team then presented our findings to Lisa. Through discussion and referring to the decision matrix we created, we and Lisa concluded that using a wood stain with a polyurethane coating on the cedar lumber we would be best. These combined techniques would provide a good aesthetic, increase the life of the wood sevenfold, and be easy to apply.



Wood Stain and Polyurethane Final Product

# Waste Management

As with any indoor or outdoor kitchen, waste is a key component that must be taken into account. For waste management, TBT currently does some composting of garden waste, feeds some food scraps to the chickens, and other waste is disposed of through the town trash service. Because the garden is right next to the proposed kitchen site, we considered having a compost bin in between the two spaces to manage the waste in the kitchen as as a source of food for the garden. We proposed this idea to agricultural planner, Connor Stedman in an interview, and he stated, “That would be a great idea for a way to not only reduce the overall waste of the kitchen, but also to act as a great teaching point for children at the farm’s programs. The educational component of the compost bin makes it an even more attractive idea.” (C. Stedman, personal communication, April 14, 2020). Our next step was to research different methods of composting to assess which method(s) would be most effective for waste management in the kitchen, as well as provide food for the garden, and educational opportunities for children in TBT’s programs.



Compost Bin

# Composting Methods



## Vermiculture

Number one method: utilizes red worms to aerate compost and break down organic material quickly with little to no smell. Minimal maintenance is required. This option is \$260.00 (Misra, R.V., Roy, R.N., & Hiraoka, H. 2003).



## Aerobic

Number two method: needs to be turned every few days to aerate organic material, but breaks down organic material efficiently without smell as long as regular maintenance is performed. This option's cost can range from \$50.00-\$250.00 (Misra, R.V., Roy, R.N., & Hiraoka, H. 2003).



## Anaerobic

Number three method: no maintenance required. Compost is thrown in bin or woods and decomposes slowly on its own. However, this method can leave an odor. This option can cost anywhere from \$20.00-\$80.00 (Misra, R.V., Roy, R.N., & Hiraoka, H. 2003).

## Subpod Grow Bundle

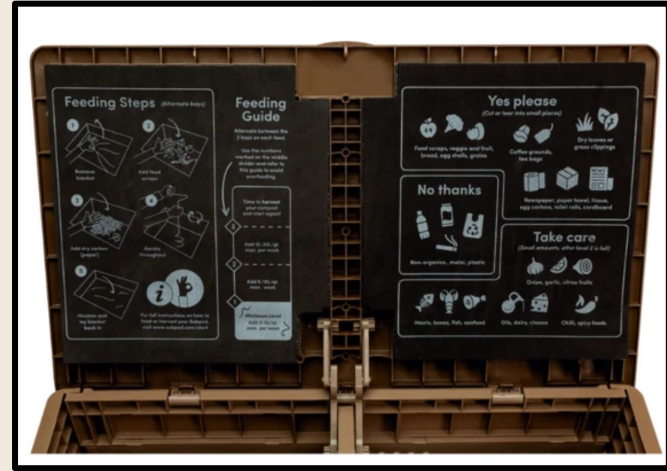

Vermiculture was found to be the most efficient composting method. Vermiculture is the process of using various types of worms to decompose organic materials into vermicast, a nutrient rich after product of completed decomposition of composted material. Vermiculture is a less time consuming option as the worms aerate the the compost thus no turning of the compost is necessary (Subpod Grow Bundle, 2020). The “Subpod Grow Bundle” is a great vermiculture composting starter kit that our team believes lisa should invest in to be able to compost food efficiently. The Subpod Grow Bundle cost \$260.00 and includes a garden bed frame, Subpod composting bin, and a warm aerator. One of the interesting things about the Subpod which is unique in comparison to other composting bins is that the instructions inside the bin, as shown in the image above to to right, have educational instructions on how to compost. These instructions mostly consist of pictures, making it easier for kids of all ages to understand the basics of composting (Subpod Grow Bundle, 2020). More information on the Subpod Grow Bundle can be found at the following link: [Subpod Grow Bundle](#).

# Immersive Educational Environment

When exploring how to add an educational aspect to our outdoor kitchen, Lisa asked us to provide an educational reference document for the teaching staff at TBT. Knowing that TBT has a number of different programs (preschool, afterschool, summer camp) for a wide range of ages (3-13), we wanted this document to include a teaching plan for a variety of different subjects. Plans for multiple subjects and ages would allow the teachers to target learning experiences for different groups, and to find educational opportunities that are fun and engaging for different aged children (Wistoft, 2013). Many children continue through TBT's programs as they get older, and the multiple subjects would allow the children to retain multiple skills from their kitchen experiences.

Research shows that outdoor gardening education can improve child and youth wellbeing, self-esteem, and stewardship of the environment. In a 2017 study by Dyg and Wistoft, they explain "Garden activities and their relations with peers, garden educators, and teachers seemed to positively affect students' self-esteem....students' relations with the natural environment seem also to affect their wellbeing as they develop empathy for animals, insects, and plants" (Dyg & Wistoft, 2018).



Educational PowerPoint Title Slide





# Six Major Teaching Points

In “*What we can learn from... Kitchens*”, the author discusses six specific teaching points that can be met through a kitchen experience, for kids aged 4 to 14. These include: safety, STEM, reading and writing, nutrition, planning and organizational skills, and responsibility (Chapman, 2016). Each of these teaching points was explained in further detail in a document with a list of lesson plans. We sent Lisa this document for review to assess whether some or all of the lessons would be a good fit for TBT and the proposed kitchen. After she reviewed it, she told the group that she would like us to focus on teaching STEM through the kitchen, as teaching STEM through outdoor play and exploration is a major focus at TBT (L. Burris, personal communication, May 4, 2020).



Safety

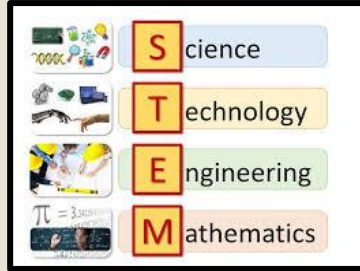

STEM



Reading and Writing



Nutrition



Planning and Organization



Responsibility

## STEM Sample Activity - Budgeted Salad

Under the STEM subject category, our group created an interactive activity that involves adding and subtracting, decision making, and preparing and cooking a meal. In this activity, the children can pick a variety of fruits and vegetables from TBT's garden, or they can be provided to the class. Each item is given a price.

According to *"What we can learn from... Kitchens"*, simple addition and subtraction, including numbers under 100, is an appropriate activity for children ages 6 to 9 (Chapman, 2016). Each student is given a total budget of \$20.00 and can purchase as many items as possible, while remaining under the budget. When each student is satisfied with the items they have purchased, the teacher will then assist the students in preparing a salad with the food that they have. Not only is this activity great for STEM purposes, but due to the garden's close proximity to the outdoor kitchen area, the kids will be able to pick or see where their vegetable options are coming from and how they grow.



# 5. Deliverables

In this section, our group will elaborate on our findings, discuss our designs in detail, as well as the generous donations made, and changes from the initial to final budget.

## **In this Section:**

Design Stages

Donations

Budget

Bringing it all Together

# Design Stages

## Phase One

Before our team could construct a budget and determine proper materials to be used, we had to decide on the best outdoor kitchen layout for TBT. The visual layouts also help us to better communicate our design ideas and processes with Lisa. Based on our research, our team decided on three different layouts, each focused on providing a good aesthetic and creating an immersive environment for approximately 10 people to interact in. When designing all the layouts, our team incorporated a wash and prep station, twin rocket stoves with a griddle and a stove top, and a brick pizza oven, which were all components requested by Lisa.

Layout #1 and Layout #2 both possessed large open areas that would allow for people to move freely and create a social environment. Layout #2 and Layout #3 were both equipped with a child wash and prep station for better access, per request of Lisa Burris. Our team also created a seating area in Layout #3, as an additional method of creating a social space. All three of these layouts were then presented to Lisa and sent out through surveys to TBT stakeholders. After reviewing the results, it was determined that Layout #2 was the most highly sought after. However, budget constraints due to COVID-19 put Layout #2 out of Lisa's budget. Therefore, we decided to move forward with Layout #1 as it is the most affordable option, which created the opportunity for add-ons from Layout #2 when TBT recovers financially.

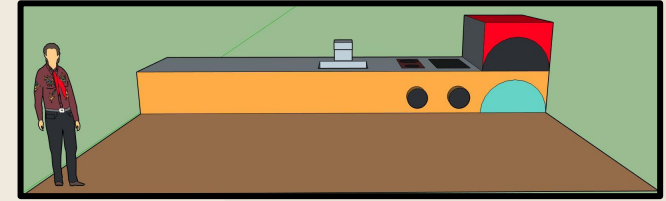

Layout #1

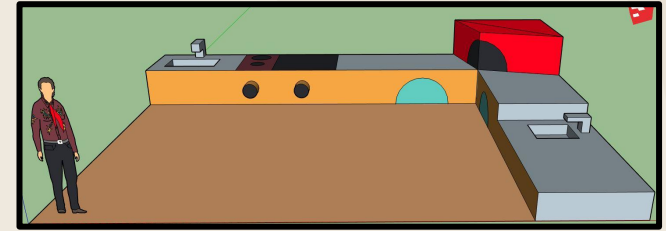

Layout #2

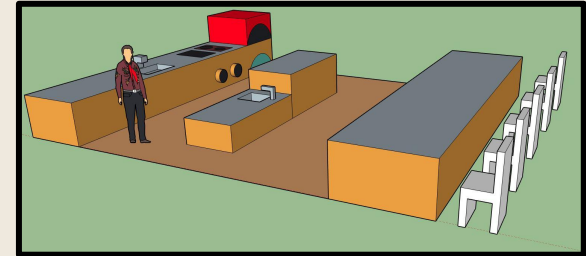

Layout #3

## Phase Two

Once our team had determined the general layout for the outdoor kitchen, we then had to create a visual that was to scale. Before determining accurate measurements, our group contacted Lisa to conduct a remote site assessment to measure the available area to construct in. Lisa informed the team that a 20' x 16' open area would be used to build the kitchen in. After learning this, our team then researched the most efficient ways for structuring the kitchen layout. Through research, we learned our layout was called a “straight kitchen” and elements our kitchen had could be placed anywhere they were desired, due to no corners or islands (Cibse, 2009). We also learned that it was standard for a countertop to be 3' high and 2' deep (Cibse, 2009). For our case, however, we decided to design the counter top 4' deep due to how large the initial brick pizza oven was supposed to be. By doing this we not only designed a frame that would support the entirety of the pizza oven, but also create a uniform kitchen that kept a consistent aesthetic. Finally, our team decided to create two prep stations that were both abutting either side of the sink. The idea behind this design was to create a separate prep stations for the pizza oven and rocket stoves. In doing this, our team aimed to use the space efficiently and decrease confusion that may occur with users trying to use one larger prep area with two separate cooking appliances.

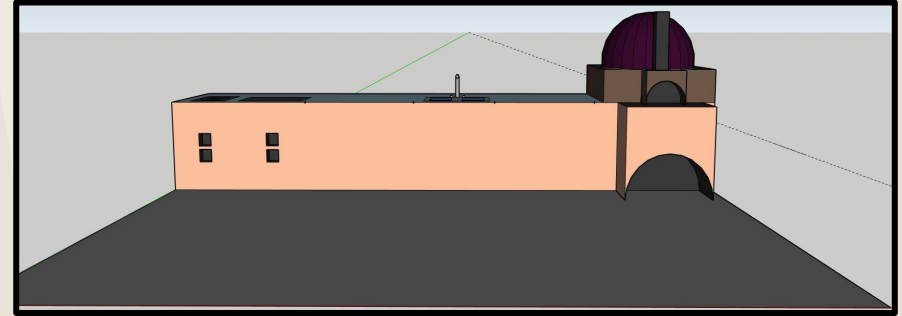

Proposed Layout with Appliances to Scale

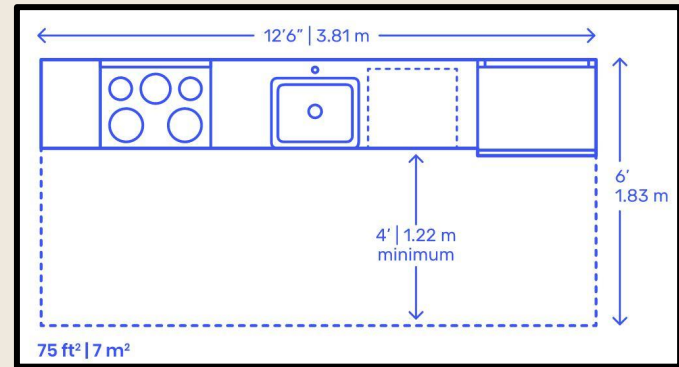

Common Indoor Kitchen Layout

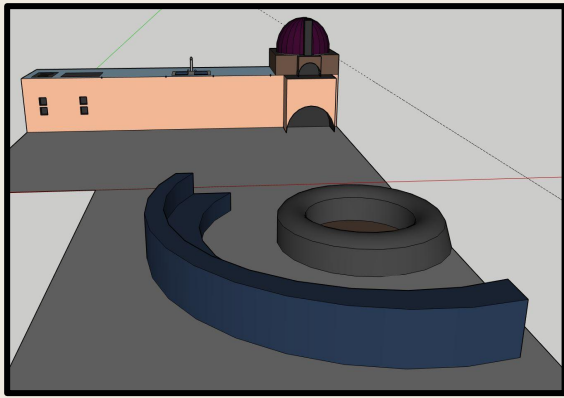

Proposed Seating Area

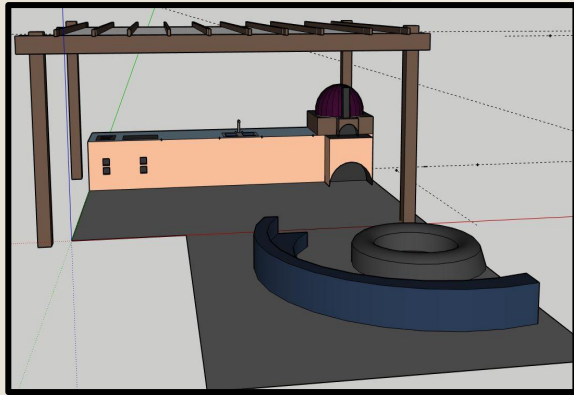

Proposed Seating Area with Pergola

After designing a layout that included twin rocket stoves, a wash station, two prep stations, and a brick pizza oven, our team presented the visual mockup to Lisa. She was pleased with the first real rendering of what TBT's future outdoor kitchen would look like, but our team and advisors could sense something was missing. Professor Rosbach suggested to Lisa and our team that a seating area should also be included. TBT already owns a pavilion, but it is an unreasonable distance away from where the kitchen was planned to be constructed. Professor Rosbach suggested a circular seating area that would create a social community environment, allowing everyone to interact with one another. It was further recommended to place the seating area around the fire pit so it may act as a multipurpose tool for both the kitchen and fire pit. Lisa mentioned that seating options were already available around the fire pit, but our team proceeded to still research and design a more permanent seating option that would follow the aesthetic of the kitchen.

We shared our research with Lisa about possible types of outdoor kitchen covers. When first hearing this idea Lisa was extremely hesitant. TBT has, unfortunately, had experience in the past with free standing structures collapsing. Although this memory plagued Lisa, our team brought up a key point. In order for the kitchen to be more appealing to be used during inclement weather, a covering would be required to offer protection. A covering would also provide the kitchen with protection from the elements, thus, increasing the longevity of its appliances, countertop, and counter frame. Lisa agreed with our analysis that a pergola would be the best fit. Wind and snow loads were not taken into consideration due to how our structure does not possess walls, and how our pergola was designed to follow and pass any building codes or inspections. By not having walls, our structure does not require this consideration and our team made sure to inform Lisa about this information.

## Phase Three

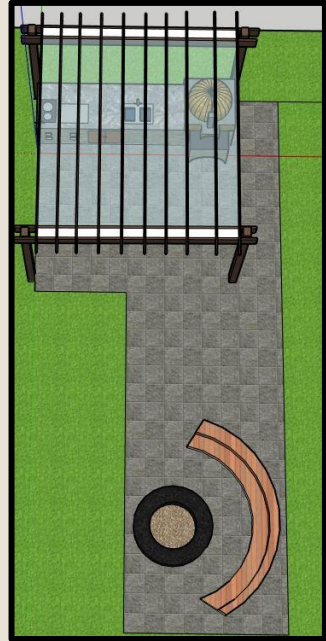

Top View

After discussing the addition of a potential covering and seating area, our team moved forward with both ideas. With the added feature of the pergola, \$1,000.00 was added onto the budget. This was a dilemma for our team because we were trying to keep costs low as possible. Through discussion with Lisa, we decided to reduce the overall size of the kitchen from (20' x 16') to (16' x 16') to reduce the overall budget. This decision was also made because of the dimensions that pre-cut lumber is available for purchase in. Unless custom ordered, lumber is available in standard 8' lengths. By shorting our overall design by 4', our team was able to then save almost \$200.00 in lumber costs.

We recalculated the to account for the added expense of a pergola and the reduced lumber costs. After presenting our findings to Lisa, she was thrilled with the idea and was onboard with the addition of a pergola. Our team also discussed the new seating proposal we had for Lisa. Currently at TBT there is a large amount of unused stone pavers that could be incorporated into the kitchen. Our team then proposed to build a large permanent stone seating semi-circle around the pre-existing fire pit. When our group informed Lisa, she did not like this idea because of how it was a permanent seating area that could not be easily disassembled and moved. Lisa was still not opposed to the idea of a seating area, however, and still wanted to receive potential seating area ideas from our team.



Front View of Kitchen  
with Seating Area

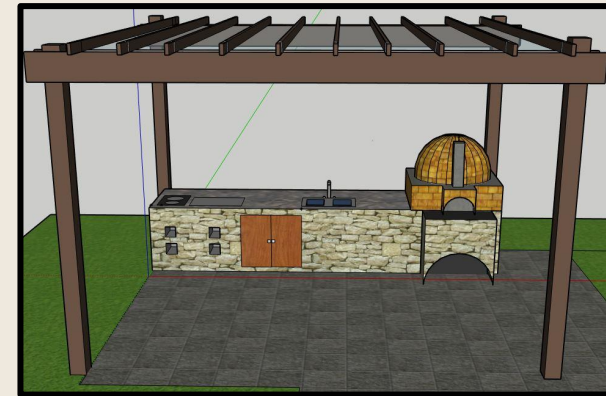

Front View of Kitchen

## Phase Four

As our team moved towards the end of the term, with added donations, we were able to put together a more finalized visual of our outdoor kitchen. Through further site assessments virtually with Lisa Burris, it was confirmed that the kitchen would consist of a 14' x 14' floor plan, and would be 8' away the fire pit and 10" to the left of the garden beds.

Our survey results showed that there was interest in having a grill as a part of the kitchen. Many individuals said that a grill is a convenient and integral part of an outdoor kitchen. With this donated item from Lisa Burris, this added element not only allows for more versatile cooking options, but it also succeeded in creating an L-shaped kitchen that was highly sought after by Lisa and other TBT stakeholders. As previously discussed, the other key donations to our kitchen were the rocket stove, the cabinets built by team member Nick, and granite countertops. Edward Ledger was a key interviewee who also generously donated both the rocket stove and the wood for the cabinets. By receiving a donated rocket stove and having the added grill, our team decided to only use one rocket stove instead of two.

The cabinets built by Nick also increased the available storage space in our final design. Finally, through connections in New Hampshire quarries, our team was able to acquire two large pieces of granite donated to our project. Each piece would be proposed to a separate countertop as seen in our visual design. Separate countertops were utilized in this case because each piece of granite was a different pattern. In order to keep a good aesthetic, our group thought it would be best to give them separate countertops. With the four donations, as well as the decreased overall foot plan, our team was able to greatly reduce the budget by \$5,916 and significantly improve the aesthetic.



Kitchen Sketch



Site Visualization with  
Garden Beds



## Phase Five

As our team was finalizing our last visual design, there were three changes our team made to the design. The first was the seating area and adjusting it to the left side of the fire pit. Our group made the seating area two 12' benches to accurately represent what was already present at TBT. Lisa requested our team do this so when presenting to stakeholders the idea of the outdoor kitchen, an accurate image would be shown.

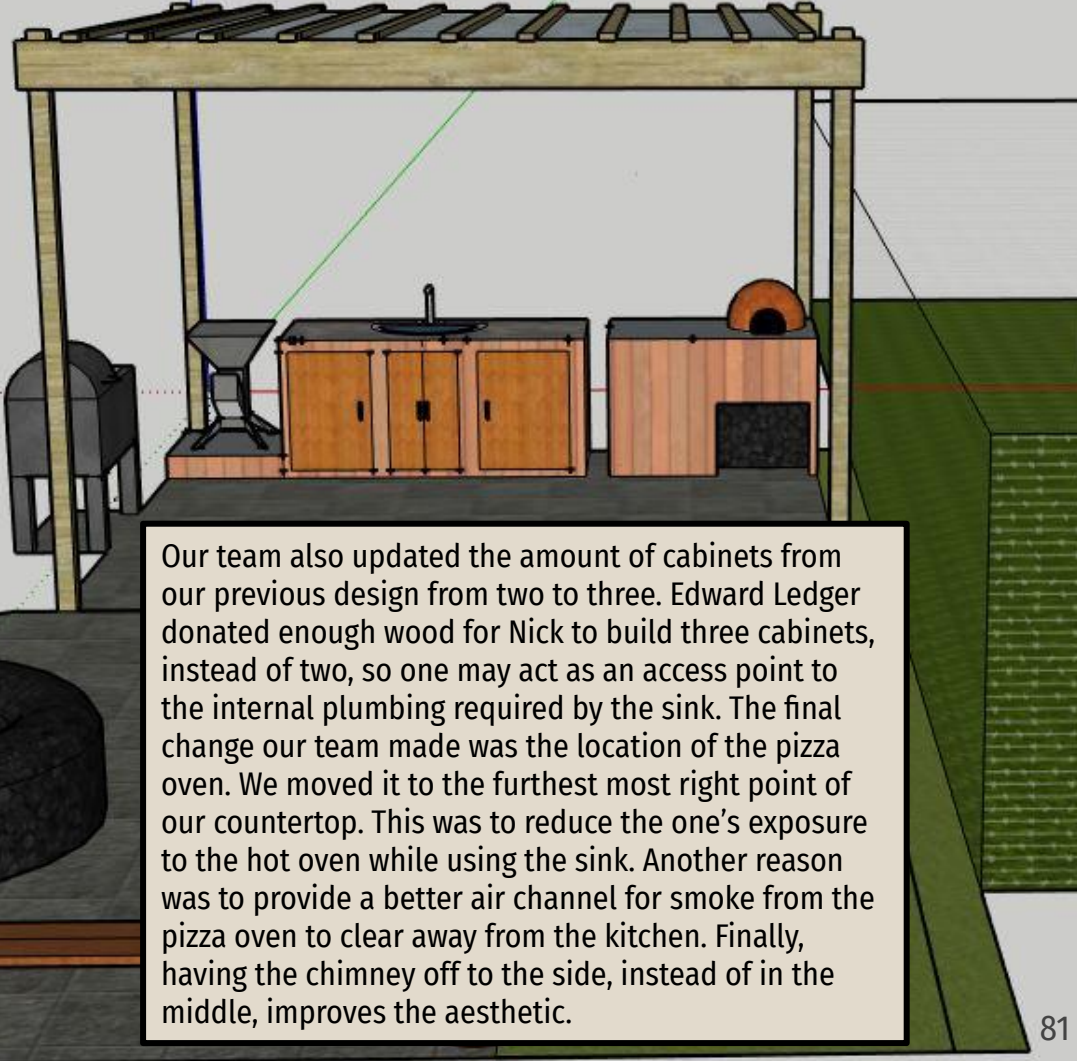

Our team also updated the amount of cabinets from our previous design from two to three. Edward Ledger donated enough wood for Nick to build three cabinets, instead of two, so one may act as an access point to the internal plumbing required by the sink. The final change our team made was the location of the pizza oven. We moved it to the furthest most right point of our countertop. This was to reduce the one's exposure to the hot oven while using the sink. Another reason was to provide a better air channel for smoke from the pizza oven to clear away from the kitchen. Finally, having the chimney off to the side, instead of in the middle, improves the aesthetic.

# Donations



Two Donated Pieces of Granite



Finished Cabinet Build

Donations were an integral part of our long-term positive impact on TBT farm. As a result of the COVID-19 pandemic, Lisa has been unable to open the farm to programs and various other events. Similar to many other small businesses and nonprofits, this pandemic has put a major financial strain on the organization. The two donations pictured on the left, are two granite countertops and a set of three cabinets. These donations decreased the kitchen's overall budget by \$4,000.00. The granite countertops were donated by two anonymous granite companies in New Hampshire, and will make up all of the counter space in the entire outdoor kitchen. The supplies for the cabinets were donated by Edward Ledger. These cabinets were made by Nick Cauley with the assistance of Edward Ledger in his warehouse.



Nick Cauley Working on Cabinet Build

Another set of donations which helped lower the final budget were previous TBT donations, which were incorporated into the final design of the kitchen. The sink, pictured just below the grill, will act as the kitchen's only source of running water. The final of these donations, pictured below, is a set of unused pavers which will be used create the kitchen patio and kitchen flooring. We are grateful to these previous TBT donors, whose contributions further helped lower our final budget.



Repurposed Grill from TBT



Available Stone Pavers at TBT



Repurposed Sink from TBT

# Budget

One of our team's greatest achievements was the ability to acquire key donations that add to the function and aesthetics of the kitchen and lower the budget. Our initial budget, shown in the chart on page 85 was \$7,742.00. However, with generous donations, we were able to reduce our budget by 76.2%, for a final budget of \$1,826.00, shown on chart on page 86.

The budget does not include venting of appliances. However, as noted beforehand, Lisa Burris believes the purchased pizza oven will not require venting. Our team has contacted two inspectors but neither was able to get back to us at this time. If venting is required by the inspector, Mark Farrell, an HVAC technician, has estimated a quote of \$500-750 (M. Farrell, personal communication, May 10, 2020). Due to the kitchen having no walls and being outdoors, a cross breeze should be enough to vent the fumes.



# Initial Proposed Budget

Item	Cost	Quantity	Total Cost	Source
Rocket Stoves (griddle and stove)	\$150.00	2	\$300.00	need to be purchased
Sink	\$0.00	1	\$0.00	TBT donation
Pergola	\$750.00	1	\$750.00	Home Depot and plexiglass cover donation
Cabinets (36"W x 35"H x 23.75"D)	\$118.00	2	\$236.00	Made from home
Pizza Oven	\$1,300.00	1	\$1,300.00	Research on diy projects for brick pizza ovens
Granite Countertop (6' x 10')	\$3,600.00	1	\$3,600.00	Stone Quarries
Stone Flooring (w/ grounded up rock and sand)	\$600.00	1	\$600.00	TBT donation (stone slabs) and Guide.com
Counter Frame (cedar 2 x 4 and nails)	\$10 (2 x 4s), \$80 (3,600 nails)	50 (2 x 4), 1 (box of nails)	\$580.00	Lowe's
Gutter (5.5" x 120")	\$8.00	2	\$16.00	Lowe's
Stain/Paint	\$15/quart	4	\$60.00	Lowe's
		<b>Initial Budget</b>	<b>\$7,442.00</b>	

# Final Proposed Budget

Item	Cost	Quantity	Total Cost	Source
Rocket Stoves (griddle and stove)	\$0.00	1	\$0.00	Donated
Sink	\$0.00	1	\$0.00	TBT donation
Pergola	\$750.00	1	\$750.00	Home Depot and plexiglass cover donation
Cabinets (36"W x 35"H x 23.75"D)	\$0.00	3	\$0.00	Made from home
Pizza Oven	\$400.00	1	\$400.00	Research on diy projects for brick pizza ovens
Granite Countertop (6' x 10')	\$0.00	1	\$0.00	Donated
Stone Flooring (w/ grounded up rock and sand)	\$600.00	1	\$600.00	TBT donation (stone slabs) and Guide.com
Counter Frame (cedar 2 x 4 and nails)	\$10 (2 x 4s), \$80 (3,600 nails)	50 (2 x 4), 1 (box of nails)	\$0.00	Lowe's
Gutter (5.5" x 120")	\$8.00	2	\$16.00	Lowe's
Stain/Paint	\$15/quart	4	\$60.00	Lowe's
		<b>Final Budget</b>	<b>\$1,826.00</b>	

# Bringing It All Together

## Final Conceptual Design

After our team was able to finalize all research, site assessments, surveys, interviews, and conceptual designs; we needed to put together a final design to instruct Lisa Burris on how to assemble the donated, pre-constructed, and purchased parts that need to be built. Our design later adjusted the design one final time to account for the pizza oven that Lisa had purchased, and to show the recommended composting bin that our team advised Lisa to purchase. Ms. Burris requested we only provide a list of instructions for how to build the pergola, as her husband has enough experience that the designs and dimensions are enough information for the rest of the build.



## Cabinets, Countertops, and Sink

The donated cabinets (frame included) are 36" high x 76" wide x 30" deep. The sink, which is 20" wide, will easily fit within the middle cabinet, which is 28" wide. The middle cabinet will act as an easy access to the sink's plumbing, while the other two cabinets are each 22" wide and will act as storage space for pots, pans, and eating utensils. The cabinets require six 5" lag bolts when they are properly placed within the design. This will ensure that the cabinets do not start to separate over time, which would lessen the life of the frame. The larger piece of donated granite will be cut to 78" wide x 32" deep, which will leave a 1" overlay on all four edges of the cabinet when placed. There will also need to be a cut in the granite where the sink will be, and this cut should be accurately done based on the exact dimensions and curve of the sink. When finally placing the granite, silicon caulking will be poured on all four edges of the top of the cabinets to ensure the granite is secure. The second piece of granite will not be included in the design at this time due to the addition of the pizza oven stand, so it will be a TBT donation that can be later included in the kitchen or used for another project.



Donated Cedar Cabinets

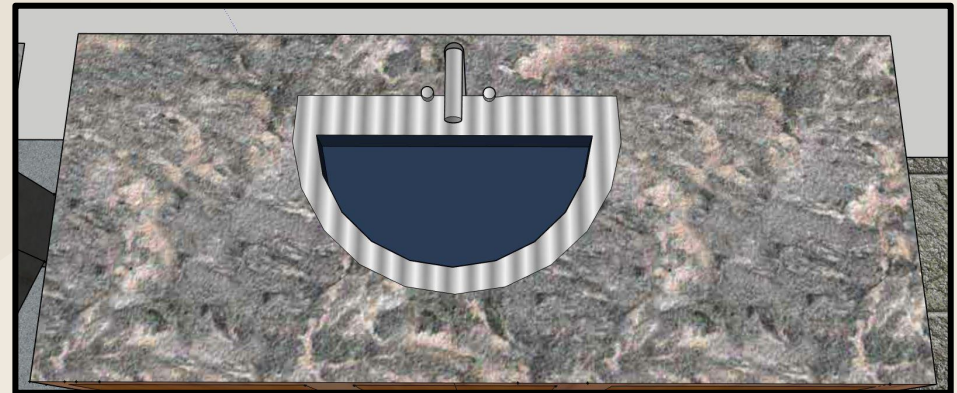

Countertop and Sink Model



## Rocket Stove

The donated rocket stove stands at 30" tall, 20" wide, and 22" front to back, so a 6" stand will be created out of cedar wood and poured concrete to make the top of the rocket stove align with the top of the adjacent counter (36" high). To allow for the rocket stove to be stored elsewhere during the winter, which will increase the longevity of the appliance, it will not be cemented into the stand. However, our team recommends that the rocket stove be secured to its stand with bolts to ensure it will not topple over during operation. One concern we had with the rocket stove was the need for a ventilation system, as the stove produces smoke. However Lisa Burris believes this will not be an issue (L. Burris, personal communication, April 7, 2020). Our research also concurs with Lisa Burris' suggestion, as pergola owner Ed Ledger, who also has a similar rocket stove in his outdoor kitchen with a pergola cover, stated that he was able to have a retired inspector come by to check out the setup, and Ed was told that rocket stoves generally let out a minor amount of smoke to the point of little concern (E. Ledger, personal communication, April 10, 2020).

Therefore, by having the rocket stove in a corner of the kitchen in a similar fashion as Ed's kitchen design, there is little to no concern about ventilation.

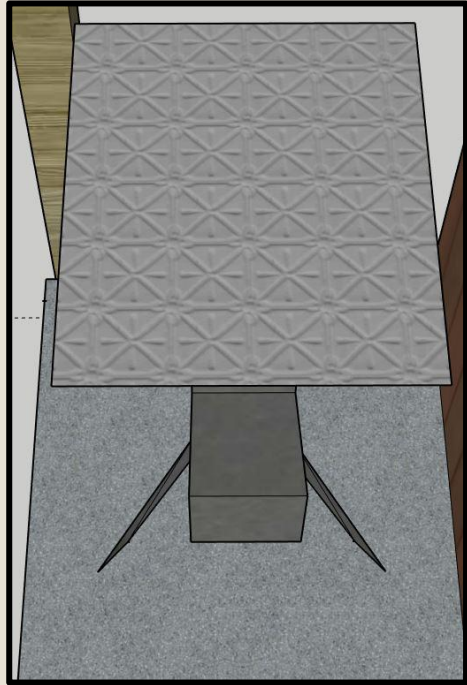

Top View of Rocket Stove Model

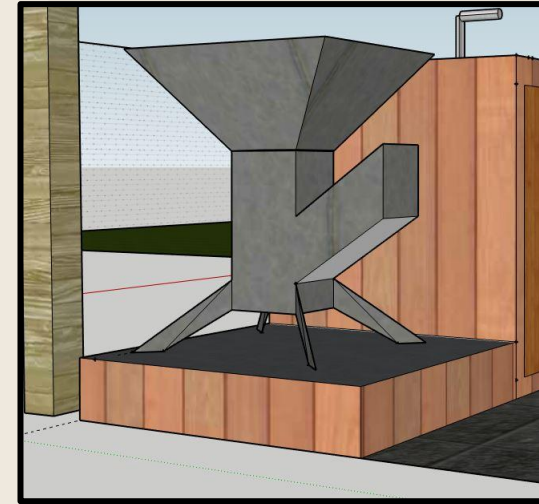

Rocket Stove Model

## Pizza Oven

One of the adjustments our team had to make from the phase five design was to incorporate the new pizza oven that Lisa had purchased. The new pizza oven was called the “Alfredo Terracotta Outdoor Pizza Oven” and has a 35” diameter, 25” tall dome, and stands 59” tall overall. Due to the larger size of this pizza oven compared to models that our team recommended, it is unable to be mounted to the previously discussed second countertop and frame. To combat this issue, our team recommended to Lisa to do away with the second frame and make the pizza oven its own stand alone structure. This can be accomplished fairly easily because the purchased pizza oven came with the added feature of a metal stand to both support the pizza oven, and will act as a storage unit to store wood for future use. Our team still recommends that Lisa place the pizza oven on the far right of the purposed kitchen area setup due to smoke management. A concern our team had was managing the smoke generated by the pizza oven. We expressed to Lisa that the model she purchased does not possess a chimney. Lisa reassured our team of this concern by saying, “It is not something that I or my husband are concerned about. A low crosswind should be enough to remove generated smoke from the kitchen area” (L. Burris, personal communication, April 7, 2020). Our team concurs with this conclusion that a pizza oven and rocket stove produce similar amounts of exhaust. The claim made by Lisa also removed the need to install a ventilation system to remove smoke, which would have also been an additional cost of \$500.00-750.00 (M. Farrell, personal communication, May 10, 2020).

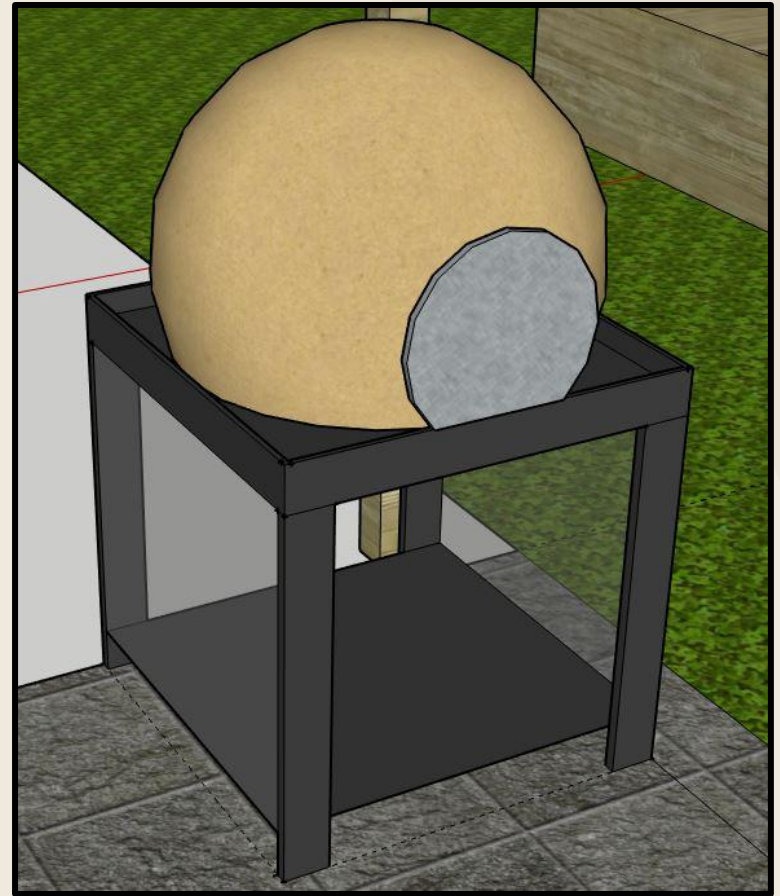

Pizza Oven Model

## Composting Bin

Our Team recommends Lisa Burris purchase the Subpod Grow Bundle to place in one of the corners of the kitchen, with dimensions of 29.5' wide' x 17.7''high x 16.9'' deep. The Subpod grow bundle has simple instructions on their [website](#) on how to assemble. This will not only add to waste management, but will also add an aesthetically pleasing garden feature included in the grow bundle. Plants and herbs can be planted in and around the composting bin to increase the aesthetic of kitchen, while still providing access to add additional composting material. This allows for easy access to fresh ingredients that may then be incorporated into meals made in the outdoor kitchen. The kitchen will also include a trash and recycling bin, provided by TBT, in the kitchen to remove waste which can not be composted. Lisa Burris has experience with composting to understand what goes in the bin and what does not. Also included on the inside cover of the Subpod are instruction on how to compost with visual diagrams for all ages to be able to understand (Subpod Grow Bundle, 2020).



Composting Bin Model

# Grill

A key addition to the outdoor kitchen through donations was the Tailgater Combo Grill. This added piece will help to try together a missing key component as we learned from interviews and survey results. The grill measures 52" x 24" x 38.5" and will provide plenty of added convenient cooking space to the future users of the outdoor kitchen. Our team recommended to Lisa that she place the grill on the left most side of the kitchen. We made this recommendation for two reasons. The first was to keep in line with our original goal of creating an "L-Shaped Kitchen". Our group preferred to put it on the right hand side to be consistent with the goal of creating an open space, but we did not make that decision based on our second reason. Since the kitchen bordered the garden beds and only offered 10" of space, our team could not recommend the grill to be placed on the right in confidence due to smoke management. Instead, we recommended to Lisa to place the grill on the left just outside of the kitchen to ensure that smoke can be blown away from the kitchen with low cross winds, as Lisa previously described. Due to the grill being just outside of the kitchen footprint, our team also recommended that a concrete foundation be poured for the grill to rest on. Stone pavers that were used to build the patio can also function as a foundation for the grill. This foundation will ensure that the grill has a level surface to rest on and will prevent any direct contact it has with the ground to increase its lifespan.

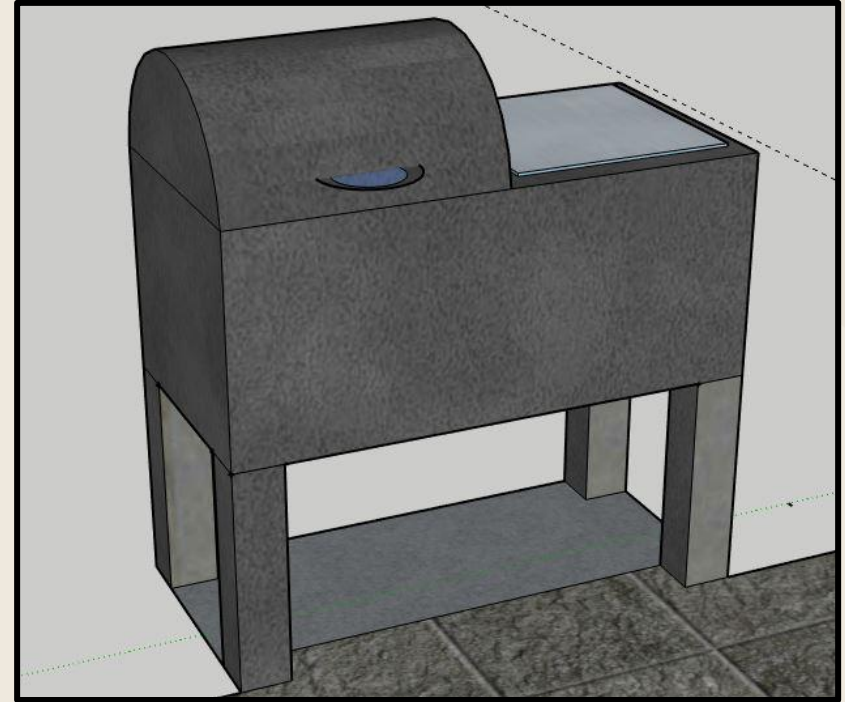

Tailgater Combo Grill Model

# Pergola

The pergola will be built as the first permanent structure of the outdoor kitchen. The pergola will cover a 14' by 14' area and the supports will be cemented into place. On the next page, there are detailed instructions on how to assemble the structure. In the future, Lisa Burris will be able to add a corrugated plastic cover on top of the pergola which will protect the inside from precipitation and debris.



Corrugated Roofing Panels with Gutter

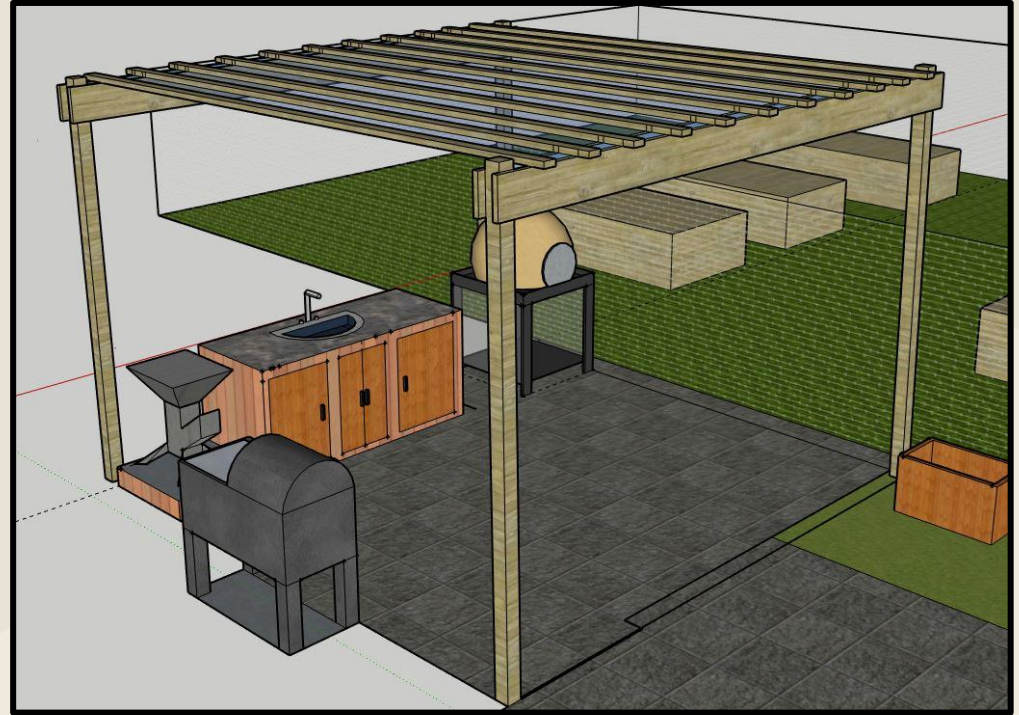

Pergola Model with Accompanying Kitchen

# Pergola Building Instructions

## Stage 1

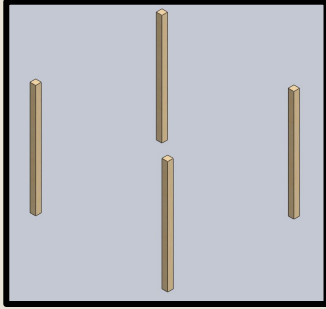

Cut two of the 7x7 posts to 11 feet 6 inches. Then dig 4, 2 foot deep holes for the posts to be set in. Mix and pour concrete to set the posts. Use 2 pieces of strapping and 2 stakes to keep the posts level as concrete dries. After concrete dries, move on to stage 2.

## Stage 2

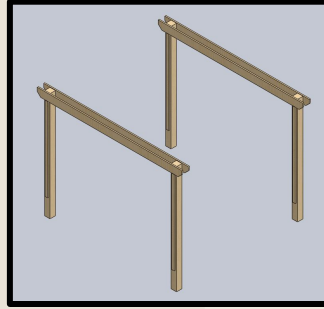

Obtain 16 foot 2 x 10's. Run through table saw at a 2 degree angle. Chamfer a 45 degree on each end of the 2 x 10's. Secure 2 x 10's to post with 2 - 12 inch bolts. Complete on all 4 posts. Make sure angled edge of 2 x 10's are facing up and turned in the correct direction. Then secure 2 x 4's underneath 2 x 10's.

## Stage 3

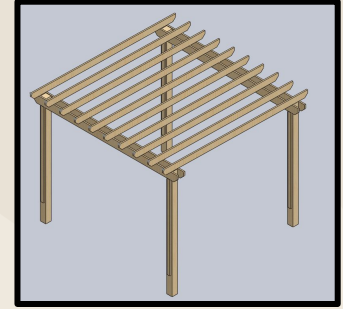

Chamfer 2 x 8's at 45 degree on each side and use 3 inch screw to secure 2 x 8's to serve as roof joists. The pergola is complete and is able to accommodate a corrugated roof, which can be drilled on top of the 2 x 8's. In the future, a rainwater catch system can be installed by adding a gutter to the lower side of the top of the pergola.

## Patio

The patio will be built with previously donated pavers after the perolga is finished. This will ensure the patio is centered in the correct place. Due to each of the four posts of the perola being 6" square posts, the dimensions of the patio within the kitchen area will be 13'6" square. The patio will be dug five inches deep to ensure pavers are flush with grass. There will be a layer of stone dust, then sand underneath the pavers to keep patio level. Next, pavers will be laid into place and gaps will be filled with grout to ensure pavers do not shift over time.

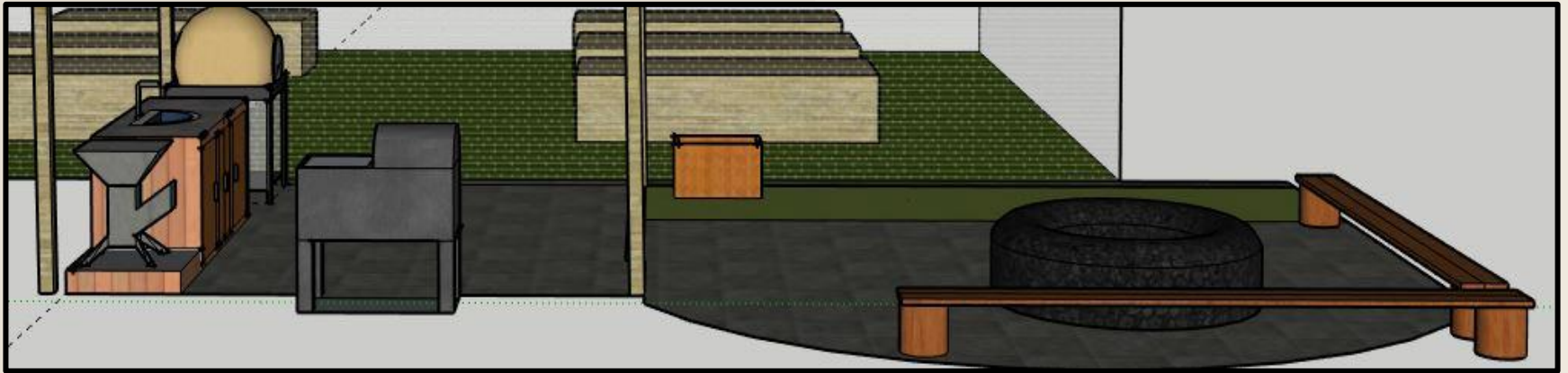

Side View of Patio Area

# Thank You!

Any questions for Turn Back Time?

lisab@tbtinc.org

978-760-3707

<https://tbtinc.org/>

CREDITS: This presentation template was created by Slidesgo, including icons by Flaticon, and infographics & images by Freepik





- Abrams, J. L., Goeden, M. C., Kean, A. J., & Hill, C. D. (2017). U.S. Patent No. 9,635,979. Washington, DC: U.S. Patent and Trademark Office.
- Cayton, R., Murray, P., Nelson, D., & Ostrowski, R. (2010). Improved weatherability of outdoor wood stains using nanotechnology. *JCT CoatingsTech*, 7(8), 38–42.
- Chawla, L. (2015). Benefits of Nature Contact for Children. *Journal of Planning Literature*, 30(4), 433–452. doi: 10.1177/0885412215595441
- Cibse. (2009). Kitchen Layout. In *Energy Efficiency in Commercial Kitchens - CIBSE TM50: 2009* (pp. 1–2). Retrieved from <https://app.knovel.com/hotlink/pdf/rcid:kpEECKCIB2/id:kt00U1IFH5/energy-efficiency-in/kitchen-layout?kpromoter=Summon>
- Cui, S., Luo, X., & Li, Y. (2017). Synthesis and properties of polyurethane wood adhesives derived from crude glycerol-based polyols. *International Journal of Adhesion and Adhesives*, 79, 67–72. <https://doi.org/10.1016/j.ijadhadh.2017.04.008>
- Cumming, A. (2011). Dutch courage. *Sanctuary: Modern Green Homes*, (14), 20-28. Retrieved April 17, 2020, from [www.jstor.org/stable/sanctuary.14.20](http://www.jstor.org/stable/sanctuary.14.20)
- Division of Fisheries and Wildlife (Ed.). (2020). Massachusetts wildlife library. Retrieved from <https://www.mass.gov/lists/massachusetts-wildlife-library>
- Dyg, P., & Wistoft, K. (2018). Wellbeing in school gardens—the case of the Gardens for Bellies food and environmental education program. *Environmental Education Research*, 24(8), 1177-1191.
- EPA. (2012, August 10). EMISSIONS FROM STREET VENDOR COOKING DEVICES (CHARCOAL GRILLING). Retrieved from [https://cfpub.epa.gov/si/si\\_public\\_record\\_report.cfm?Lab=NRMRL&dirEntryId=63458](https://cfpub.epa.gov/si/si_public_record_report.cfm?Lab=NRMRL&dirEntryId=63458)
- EPA. (2018, September 17). Choosing the Right Wood-Burning Stove. Retrieved from <https://www.epa.gov/burnwise/choosing-right-wood-burning-stove>
- Forno Bravo. (2020). Pizza Oven Size Guide: Selecting A Pizza Oven: Forno Bravo. Retrieved from <https://www.fornobravo.com/how-to-select-an-oven/pizza-oven-guide/>
- Grilling Safety (2020). Mass.gov. Retrieved February 10, 2020, from <https://www.mass.gov/service-details/grilling-safety>

- Gurwitt, R. (2009). Any way you slice it: Sundays at the community oven aren't just about the pizza. *American Scholar*, 78(3), 74–81.
- Home Depot. (2020). Wood & Deck Stain - Exterior Stain & Sealers. Retrieved from <https://www.homedepot.com/b/Paint-Exterior-Stain-Sealers-Wood-Deck-Stain/N-5yc1vZbbbm>
- Home Depot. (2020). Polyurethane Wood Finish - Wood Finishes. Retrieved from <https://www.homedepot.com/b/Search/N-5yc1vZaqst/Ntk-Extended/Ntt-polyurethane?Ntx=mode+matchpartialmax&NCNI-5>
- Mathewson, G. (2018, September 10). Code Requirements for Outdoor Kitchen. *Professional Deck Builder*. From [https://www.deckmagazine.com/outdoor-living/structures-features/code-requirements-for-outdoor-kitchens\\_o](https://www.deckmagazine.com/outdoor-living/structures-features/code-requirements-for-outdoor-kitchens_o)
- National Safety Council. (2020). Safety at Home. Retrieved February 10, 2020, from <https://www.nsc.org/home-safety/safety-topics>
- Misra, R. V., Roy, R. N., & Hiraoka, H. (2003, January 1). On-Farm Composting Methods. Retrieved from <https://vtechworks.lib.vt.edu/handle/10919/65466>
- Pizza Planet. (2018, March 30). Why Does A Pizza Oven Need To Be So Hot? Retrieved April 7, 2020, from <https://www.pizzaplanet.com/pizza-oven-need-hot/>
- Rocket stove reduces use of fuel wood. (2006). *Appropriate Technology*, 33(3), 57-58. From <http://ezproxy.wpi.edu/login?url=https://search-proquest-com.ezpxy-web-p-u01.wpi.edu/docview/200039887?accountid=29120>
- Stringer, Ashley, et al. "Design of Rainwater Harvesting Systems in Oklahoma." (2016).
- The Ashden Awards for Sustainable Energy: "Rocket stove" reduces use of fuel wood. (2006). *Appropriate Technology*, 33(3), 57–58.
- Turn Back Time. (2019). Retrieved from <https://tbtinc.org/>
- Welcome to the Town of Paxton. (2019). Retrieved from <https://www.townofpaxton.net/>
- Whirlwind Team. (2018, July 11). Designing a Building to Withstand Heavy Snow. Retrieved April 7, 2020, from <https://www.whirlwindsteel.com/blog/bid/264596/designing-a-building-to-withstand-heavy-snow>
- Wistoft, K. (2013). The desire to learn as a kind of love: gardening, cooking, and passion in outdoor education. *Journal of Adventure Education & Outdoor Learning*, 13(2), 125-141.

- WPI (Ed.). (2019, February 28). WPI Launches Global Projects For All Initiative to Give Every Student Access to Off-campus Project Experiences. Retrieved April 7, 2020, from <https://www.wpi.edu/news/wpi-launches-global-projects-all-initiative-give-every-student-access-campus-project>
- Zielinski, G. A., & Keim, B. D. (2005). *New England Weather, New England Climate*. UPNE.
- Zline. (2020). Build.com. Retrieved March 4, 2020. From [https://www.build.com/zline-695-304-34/s1445085?uid=3400998&source=gg-gba-pla\\_3400998!c1714656606!a69939763667!dc!ng&gclid=CjwKCAjw7LX0BRBiEiwA\\_\\_gNw3D-SQP7x3OnG7rFidY0imEBV9EV5\\_Abt3eXW0uRcCa2oYMDWWTY7xoCyw8QAvD\\_BwE&gclsrc=aw.ds](https://www.build.com/zline-695-304-34/s1445085?uid=3400998&source=gg-gba-pla_3400998!c1714656606!a69939763667!dc!ng&gclid=CjwKCAjw7LX0BRBiEiwA__gNw3D-SQP7x3OnG7rFidY0imEBV9EV5_Abt3eXW0uRcCa2oYMDWWTY7xoCyw8QAvD_BwE&gclsrc=aw.ds)

- Almy, Z. (Photographer). (April 2020). *Personal Photographs* [photograph]. Stow, Massachusetts.
- Burris, L. (Photographer). (2016-2019). *Turn Back Time Facebook* [photograph]. Paxton, Massachusetts.
- Burris, L. (Photographer). (April 2020). *TBT Donations* [photograph]. Paxton, Massachusetts.
- Cauley, N. (Photographer). (April 2020). *Personal Photographs* [photograph]. Milford, New Hampshire.
- Coyote. (1999, Oct 31). How to: Build A rocket stove. *Earth First!*, 19, 25. Retrieved from <http://ezproxy.wpi.edu/login?url=https://search-proquest-com.ezpxy-web-p-u01.wpi.edu/docview/221813494?accountid=29120>
- Designing a Contemporary Outdoor Kitchen Near Your Pool. (2019, July 5). Retrieved from [http://www.google.com/imgres?imgurl=https://www.creekstoneoutdoors.com/site/wp-content/uploads/2019/04/SterlingCreek\\_10-1080x675.jpg&imgrefurl=https://www.creekstoneoutdoors.com/designing-a-contemporary-outdoor-kitchen-near-your-pool/&tbnid=jvbeFMGJtahgWM&vet=12ahUKEwrt\\_WI6ernAhVKBd8KHVajCvsQMygRegUIARD1Ag.i&docid=lcm2w93ytA1L9M&w=1080&h=675&q=outdoor+kitchen](http://www.google.com/imgres?imgurl=https://www.creekstoneoutdoors.com/site/wp-content/uploads/2019/04/SterlingCreek_10-1080x675.jpg&imgrefurl=https://www.creekstoneoutdoors.com/designing-a-contemporary-outdoor-kitchen-near-your-pool/&tbnid=jvbeFMGJtahgWM&vet=12ahUKEwrt_WI6ernAhVKBd8KHVajCvsQMygRegUIARD1Ag.i&docid=lcm2w93ytA1L9M&w=1080&h=675&q=outdoor+kitchen)
- Kamikawa, D., Weng, W. G., Kagiya, K., Fukuda, Y., Mase, R., & Hasemi, Y. (2005). Experimental study of merged flames from multifire sources in propane and wood crib burners. *Combustion and flame*, 142(1-2), 17-23.
- McDonald, T. (Photographer). (April 2020). *Personal Photographs* [photograph]. Worcester, Massachusetts
- McPherson, A. (2014, January 4). Who Decides to Shut Down a City for a Snowstorm? Retrieved April 7, 2020, from <https://www.nationalgeographic.com/news/2014/1/140103-blizzard-snow-storm-city-closure-climate-weather-science/close>
- Pinterest. (2019). Retrieved from [https://www.google.com/imgres?imgurl=https://i.pinimg.com/originals/56/ce/dc/56cedcdc81062de9/&tbnid=kEyt1iETv9aiXM&vet=12ahUKEwi-3K3g7ernAhXYHd8KHasiCyYQMygZegQIARBF..i&docid=1mGLhf\\_aIYWCuM&w=640&h=480&q=outdoor+kitchen+designs&ved=2ahUKEwi-3K3g7ernAhXYHd8KHasiCyYQMygZegQIARBFddecf50c98b4934a6.jpg&imgrefurl=https://www.pinterest.com/pin/21195072619160899](https://www.google.com/imgres?imgurl=https://i.pinimg.com/originals/56/ce/dc/56cedcdc81062de9/&tbnid=kEyt1iETv9aiXM&vet=12ahUKEwi-3K3g7ernAhXYHd8KHasiCyYQMygZegQIARBF..i&docid=1mGLhf_aIYWCuM&w=640&h=480&q=outdoor+kitchen+designs&ved=2ahUKEwi-3K3g7ernAhXYHd8KHasiCyYQMygZegQIARBFddecf50c98b4934a6.jpg&imgrefurl=https://www.pinterest.com/pin/21195072619160899)
- Simple Outdoor Kitchen Designs. (2019, April 13). Retrieved from <http://1goodstyle.info/simple-outdoor-kitchen-designs/>
- Turn Back Time. (2019). Retrieved from <https://tbtinc.org/>
- Welcome to the Town of Paxton. (2019). Retrieved from <https://www.townofpaxton.net/>